

**XEROX 6085 PCS  
PRODUCT SUPPORT MANUAL  
OCTOBER, 1985**

**Prepared By:  
Xerox Corporation  
Office Systems Division  
Customer Service/Service Education  
701 S. Aviation Blvd. MS N2-19  
El Segundo, California 90245**

**Copyright©1985 by Xerox Corporation  
Xerox® is a Trademark of Xerox Corporation  
Printed in U.S.A.**

## **HOW TO USE THIS MANUAL**

This manual is designed to follow the step-by-step sequence of a typical service call. A service call normally consists of the following steps:

**INITIAL ACTIONS** are used to determine the nature of the problem, i.e. whether the problem is operator-related or is due to a machine failure. Functional tests direct you to the correct Repair Analysis Procedure.

**REPAIR ANALYSIS PROCEDURES** provide instructions to help you troubleshoot a machine fault down to the correct field replaceable unit (FRU).

**REPAIR INFORMATION** includes the Parts Identification section and the removal, replacement and repair procedures necessary to repair problems identified in the Repair Analysis section.

**FINAL ACTIONS** is the last part of the service call at which point you verify that the machine is functioning correctly and complete any administrative tasks.

**GENERAL INFORMATION** contains information about Tools and Consumables and Machine Specifications.

**WIRING DATA** shows the location of the various plugs and jacks and has wire destination drawings.

**PRINCIPLES OF OPERATION (PSS ONLY)** is an overview of the purpose and function of the major 6085 subsystems. It is intended to give an overall picture of how the system operates.

The chart on the opposite page serves two purposes: (1) as a callguide and (2) as an index to the manual. As a callguide, it gives the Service Representative the steps of the service call in the order in which they occur. As an index, it identifies where the information is needed to support each service call step can be found in the manual.

To use this manual, follow the call guide on the opposite page. Begin by opening to the Preliminary Action Checklist in the first section of the manual and complete the activities listed. The PAC will direct you to the next activity in the service call.

Material which is typically not used on every service call is included in a General Information appendix at the end of the manual.

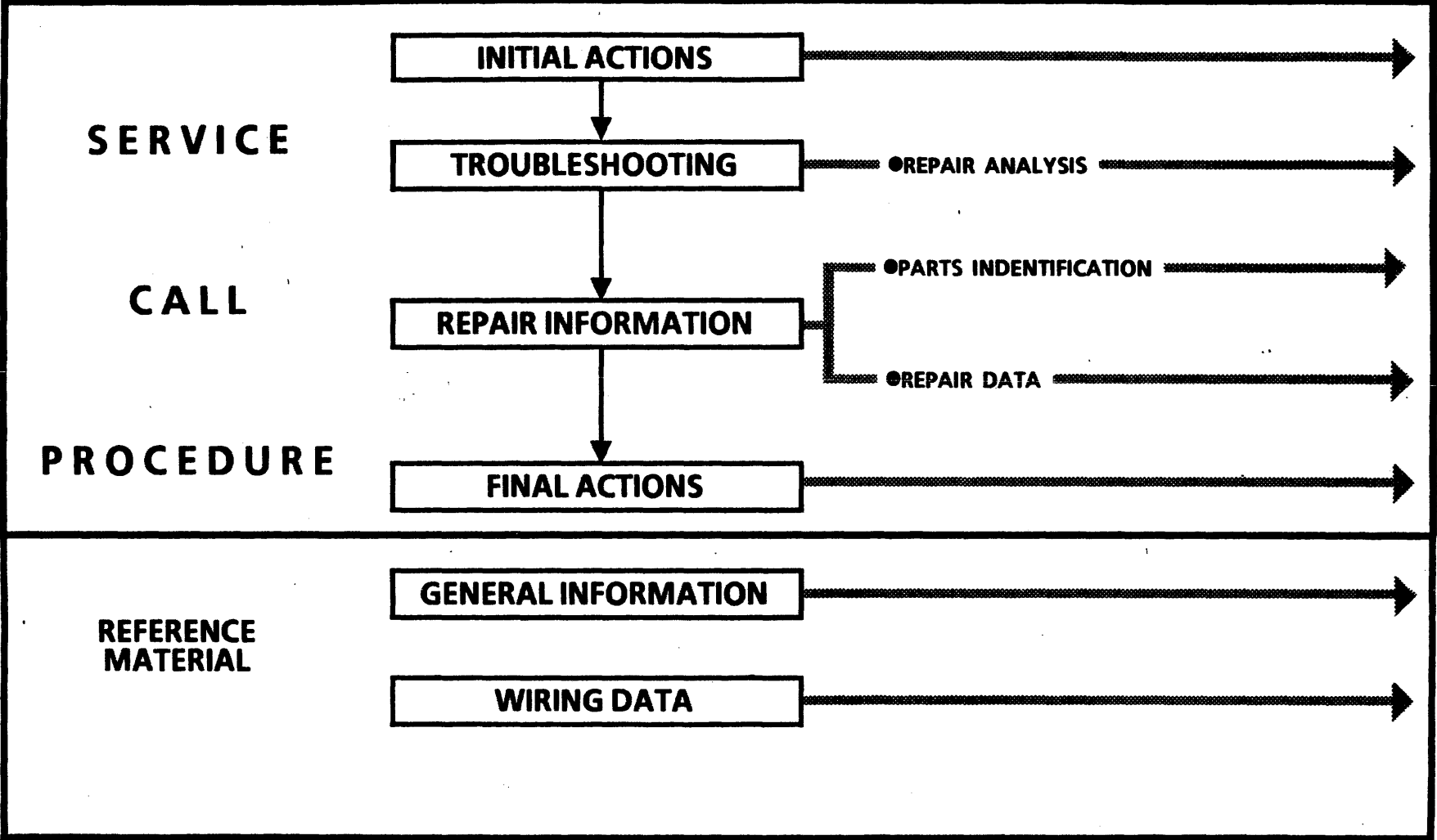

**SERVICE**

**CALL**

**PROCEDURE**

**REFERENCE  
MATERIAL**

**INITIAL ACTIONS**

**TROUBLESHOOTING**

**REPAIR INFORMATION**

**FINAL ACTIONS**

**GENERAL INFORMATION**

**WIRING DATA**

●REPAIR ANALYSIS

●PARTS IDENTIFICATION

●REPAIR DATA

**1**

**2**

**3**

**4**

**5**

**6**

**7**

**CHAPTER 1 INITIAL ACTIONS  
6085 Product Support Manual**

## INITIAL ACTIONS

### GENERAL TROUBLESHOOTING PROCEDURES

- Always perform the System Check.
- The System Check procedures should be performed in the given order except when the fault is obvious or when a specific replacement part is not readily available.
- If the System Check and/or Repair Analysis Procedures (RAPs) have not led you to the resolution of the problem, call for assistance before attempting to troubleshoot without specific directive steps.
- Before removing a part that is suspected to be faulty, look for any obvious fault (such as loose connectors, foreign objects, etc.).
- After completing each corrective action (replacing or adjusting a part, reseating a connector, etc.) perform the Final Actions to verify the repair. (If necessary, reconnect connectors and/or reinstall parts removed during fault isolation.)
- After the repair is verified, reinstall any good parts which may have been removed during fault isolation.

- Some of the screen displays shown in this section are samples which represent only one machine configuration. During System Check, your machine may display different information depending on the hardware installed (such as memory size, rigid disk size, type of display, etc.) and software configuration.

Figure 1-1 shows the general sequence of actions during a Service Call.

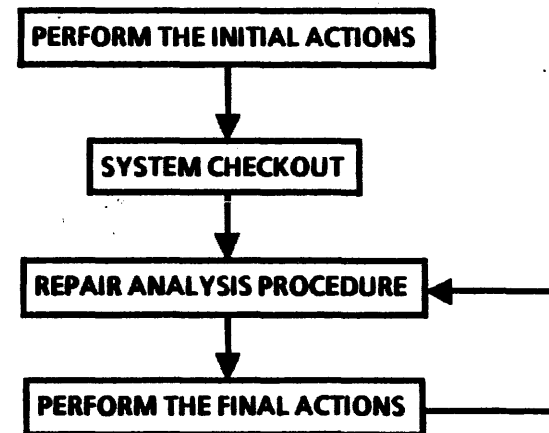

Figure 1-1 Service Call sequence

**INITIAL ACTIONS**

1. Ask the operator about the symptoms of the fault and make a note of any status codes or descriptions of problems. (This information may aid you in diagnosing the problem in the case of intermittent or unusual machine faults.)
2. Perform the System Check.

**SYSTEM CHECK**

The purpose of the System Check is to enable the service representative to run the machine and observe its operation. It is designed to find machine problems. Use the problems observed during the test and refer (by RAP number) to the appropriate Repair Analysis procedure in the next chapter to repair the problem.

**PREPARATION**

Prior to performing the actual System Check Procedures on the next page, perform the following general actions.

1. Check for an obvious problem (loose connections, broken part), and repair (Section 4).
2. Check that display, keyboard, power cord, and if applicable, floppy disk drive and Ethernet connectors are secure.
3. If multiple workstations have the same problem, call for assistance.

## INITIAL ACTIONS

### PROCEDURE

1. Green Power Normal Indicator is on.  
YES ↓ NO → Go to RAP 1
2. The processor fans are audible.  
YES ↓ NO → Go to RAP 2
3. Press System Reset button to start Pre-Boot Diagnostics and observe the three red Pre-Boot Indicators. To avoid a false error tone, do not press any keys on the keyboard or mouse while the Pre-Boot Diagnostics are running. Within 10 seconds and after having cycled through a sequence of on and off combinations, all three of the Pre-Boot Indicators are off.  
YES ↓ NO → Go to RAP 3
4. The system ran during the Pre-Boot sequence without emitting a beep tone.  
YES ↓ NO → Go to RAP 10

5. The Boot Softkeys are displayed.



YES ↓ NO → Go to RAP 11

6. Select the Workstation Diagnostics Boot Function Key.(F5)



7. In approximately 2 minutes, the machine completes Boot Diagnostics successfully by displaying the Boot Softkeys:



YES ↓ NO → Go to RAP 4

## INITIAL ACTIONS

8. Insert the Off-Line Rigid Disk Diagnostics floppy into the floppy disk drive and select the Floppy Boot Function Key.(F2) Or select the Off-Line Rigid Disk Diagnostics from the Ethernet Executive Menu. (F3)

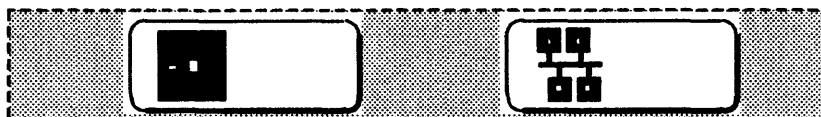

Floppy Boot Softkey    Ethernet Boot Softkey

9. After pressing any key to get from the Identification Menu to the logon menu, type a <1> and a <Return> for User.
10. In the Test Selection menu, type a < 1 > and a <Return> to select the Confidence Test. The Confidence Test passes.  
YES ↓ NO → Go to RAP 9
11. A known problem still exists.  
YES ↓ NO → Go to Final Actions

12. The reported problem with the workstation is related to:

Ethernet	→	Go to RAP 6
Floppy Disk	→	Go to RAP 7
RS-232-C	→	Go to RAP 8
Keyboard/Mouse	→	Go to RAP 10
Display	→	Go to RAP 11

(Unknown) ↓

13. If an unresolved machine problem still exists, perform System Check a second time with the Long Boot Diagnostic option by pressing the Boot Diagnostics Function Key (F5) two times.

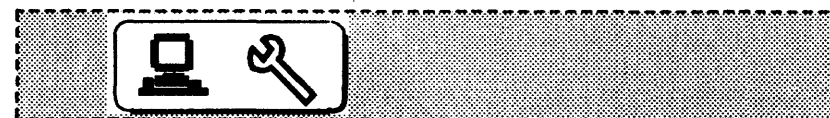



## **INITIAL ACTIONS**

---

- 14. If after running System Check twice, an unresolved machine problem still leads to this step, call for assistance.**

**CHAPTER 2 REPAIR ANALYSIS**  
**6085 Product Support Manual**

## REPAIR ANALYSIS

### RAP 1 No green light

1. Disconnect the AC power cord from the wall outlet.  
Voltage at the wall outlet is 103 to 127 VAC.  
YES ↓ NO → Notify customer of power needs.
2. Check the DC voltages as shown in Figure 2-1 for the following specifications:  

+ 5 VDC	=	+ 5.15 to + 5.25 VDC
-5.2 VDC	=	-5.05 to -5.35 VDC
+ 12VDC	=	+ 11.83 to + 12.57 VDC
-12VDC	=	-11.64 to -12.36 VDC
3. Voltage is present.  
YES ↓ NO → Replace the power supply fuse.
4. One or more of the above voltages is below acceptable range.  
YES ↓ NO → Go to Step 8

**NOTE:** To ensure accurate results in the following procedure, there must be sufficient electrical loading of the Power Supply. This is accomplished by having at least

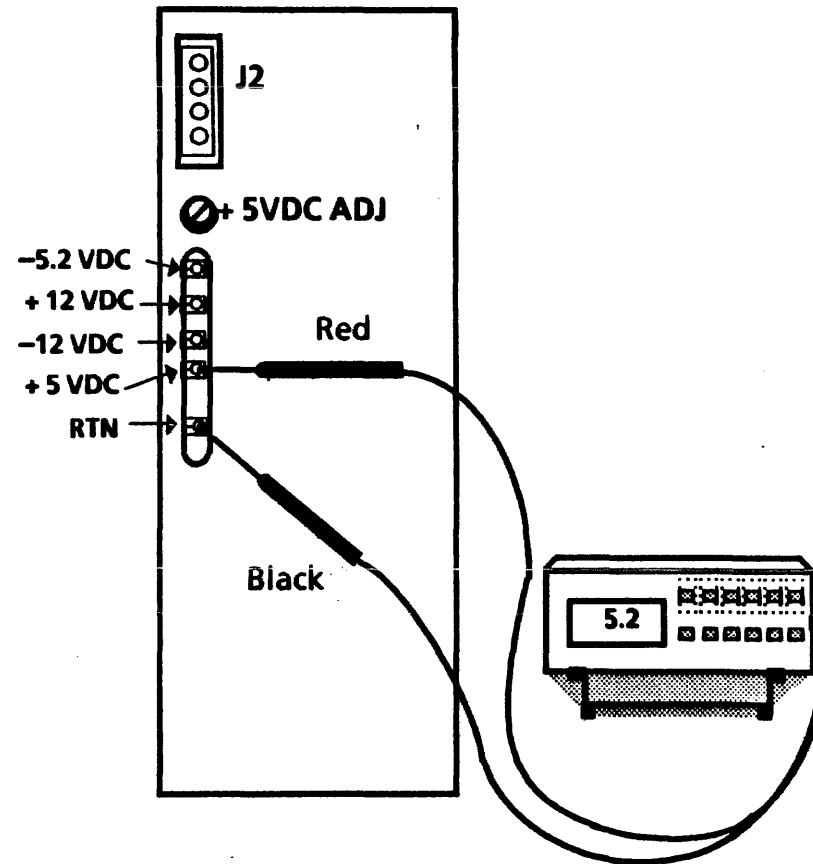

Figure 2-1 DC Voltages Check

one PWBA connected to the backplane at all times. As each PWBA is disconnected, it should be reconnected before the next suspect PWBA is disconnected.

5. Unplug the PWBAs, the Rigid Disk Drive, the Fan Assembly, and the Floppy Disk Drive connectors one at a time and recheck the DC voltages. The voltage(s) return to within acceptable range.  
YES ↓ NO → Go to Step 7
6. Replace the component(s) that caused the voltage drop. The problem still exists.  
YES ↓ NO → Go to Final Actions
7. Perform the Repair procedures in the +5VDC Check (Repair 4.9). +5VDC is within acceptable range.  
YES ↓ NO → Replace the power supply
8. Switch power off, wait 10 seconds, then switch power on. Green light is still inoperative.  
YES ↓ NO → Go to Final Actions
9. Replace the power supply. If the problem still remains, call for assistance.

**RAP 2 Fans not audible**

1. Observe fan operation.
  - a. Switch off the system power.
  - b. Access the back of the processor.
  - c. Remove the Rigid Disk Drive and the PWBA in position C2 (second PWBA slot from the left) so that all three of the fans can be observed.
  - d. Switch on the system power.
  - e. Using a flashlight, inspect all three fans for normal speed of rotation.
2. Follow the appropriate step:  
**All fans rotate properly** → Go to Final Actions  
**One or two fans rotate** → Replace the Fan Assy. (4.4)  
**None of the fans rotate** ↓
3. Check for +11.83 to +12.57 VDC at the fan connector.
  - a. Remove the Fan Assembly from the machine. Locate the Fan Assembly plug/jack. (It is visible through the Rigid Disk Drive cavity in the processor.)
  - b. Select the 20 volt DC scale on the multimeter (600T1616).

## REPAIR ANALYSIS

- c. Reach in through the Rigid Disk Drive cavity and connect the meter leads to the Fan Assembly connector as shown in Figure 2-2.
- d. If the reading is +11.83 to +12.57 VDC, check that the connector pins are making good contact. If the contacts are good and the fans still do not operate, replace the Fan Assembly (4.4).
- e. If no voltage is read, check that the cable from the connector to the backplane is properly seated. If reseating the connector doesn't solve the problem, call for assistance.

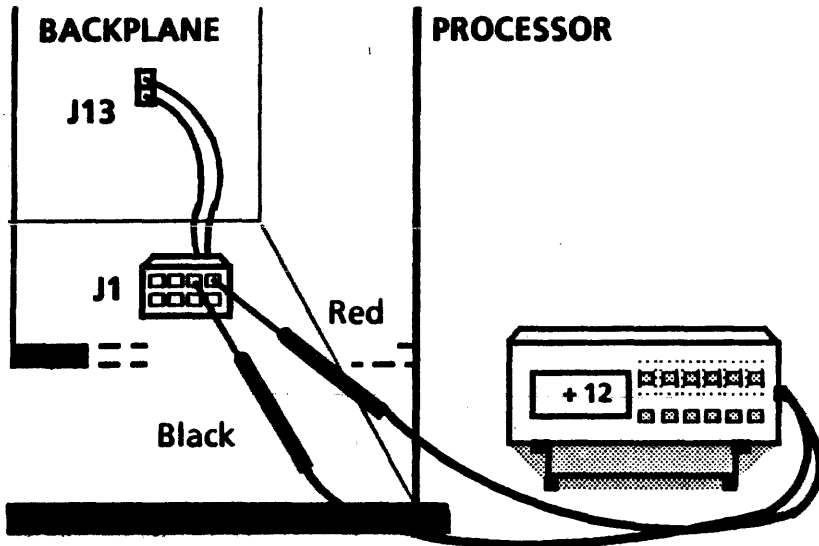

Figure 2-2 Fan Connector and Backplane

### RAP 3 Pre-Boot Failure

**NOTE:** Prior to Pre-Boot, all three indicator lights should be off. Then to begin Pre-Boot Diagnostics, all three indicator lights should come on briefly. If the softkeys appear on the display but the indicators did not appear to light in sequence, the processor has passed Pre-Boot and one or more indicator lights is burned out. The only way to repair the lights is to replace the power supply.

1. All three of the Pre-Boot Indicators light during the running of the Pre-Boot Diagnostics.  
YES ↓ NO → Step 3
2. Refer to the Table 2-1 for indicator status, and replace the components as necessary in the sequence given.
3. Replace the IOP (4.12). If problem is still not fixed, then replace the Power Supply (4.8).

Table 2-1 Pre-Boot Failure Indicators / Repair Analysis	
Indicators*	Component(s) to replace
■ ■ ■	Normal operation
■ ■ □	Boot PROMs (4.13), IOP (4.12)
■ □ ■	IOP (4.12)
■ □ □	IOP (4.12)
□ ■ ■	Keyboard, IOP (4.12)
□ ■ □	EEPROM (4.16), , IOP (4.13)
□ □ ■	ID PROM (4.16), , IOP (4.13)
* ■ = Indicator On, □ = Indicator Off	

**RAP 4 Boot Diagnostics Failure**

1. The Boot Diagnostics sequence stopped on a Cursor Code.  
YES ↓ NO → Go to Step 4
2. All Cursor Code digits are visible.  
YES ↓ NO → Replace the DCM PWBA (4.14)

3. Proceed to RAP 12.
4. Run Floppy Boot Diagnostics (F6), or Ethernet Boot Diagnostics, if machine does not have a floppy disk drive by selecting the appropriate Function Key.(F7)

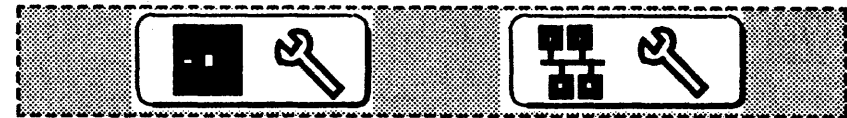

5. In approximately 4-5 minutes, the machine completes Boot Diagnostics successfully by displaying the Boot Softkeys:



YES ↓ NO → Go to Step 1

6. Go to Rap 9.

**RAP 5 TBD**

## REPAIR ANALYSIS

### RAP 6 Ethernet Checkout

1. Run the Ethernet Boot Diagnostics by selecting the Ethernet Boot Diagnostics Function Key. (F7)



2. The cursor box appears in the middle of the display.  
YES ↓ NO → Go to Step 6
3. Follow these procedures to verify Ethernet operation:
  - a. When the cursor box is in the middle of the display, press the <STOP> key to prepare the system for test sequence entry.
  - b. Press the < F > key and then the < E > key to boot the Ethernet test File.
  - c. With the Cursor Code at [ OD99 ], press the < S > key and then the < 2 > key to Specify Test Option 2, which is the External Ethernet test option. Press the <Return> key to begin the test.

4. The test completes successfully by stopping at Cursor Code [ OD99 ].  
YES ↓ NO → Go to Step 6
5. Ethernet operation of the workstation has just been verified operational. Proceed to Final Actions.
6. Run the Ethernet Loopback Test at the IOP PWBA by following these procedures:
  - a. Disconnect the drop cable from the E-Net port on the IOP PWBA and connect the Universal Loopback Tool (Ethernet Loopback) to that port on the IOP PWBA.
  - b. Select the Workstation Diagnostics Boot Function Key.(F5)



- c. When the cursor box is in the middle of the display, press the <STOP> key to prepare the system for test sequence entry.
- d. Press the < F > key and then the < E > key to boot the Ethernet test File.
- e. With the Cursor Code at [ OD99 ], press the < S > key and then the < 2 > key to Specify Test

Option 2, which is the External Ethernet test option. Press the <Return> key to begin the test.

7. The test completes successfully by stopping at Cursor Code [ OD99 ].  
YES ↓ NO → Replace the IOP PWBA
8. The transceiver is accessible without using a ladder.  
YES ↓ NO → Call for assistance
9. Run the Ethernet Loopback Test through the drop cable by following these procedures:
  - a. Reconnect the drop cable to E-Net port on the IOP PWBA. Disconnect the drop cable from the transceiver and connect the Universal Loopback Tool (Ethernet Loopback) to that end of the Ethernet cable.
  - b. With the Cursor Code at [ OD99 ], press the < I > key to rerun the (In memory) test, which is presently the External Ethernet test option 2.
10. The test ends with the Cursor Code [ OD99 ].  
YES ↓ NO → Replace the drop cable

11. Run the Ethernet Loopback Test through the transceiver by following these procedures:
  - a. Remove the transceiver from the Ethernet and remove the rubber gasket from the "stinger" end of the transceiver. Connect the Transceiver Terminator Tool to the "stinger" end of the transceiver and reconnect the drop cable to the transceiver.
  - b. With the Cursor Code at [ OD99 ], press the < I > key to rerun the (In memory) test, which is presently the External Ethernet test option 2.
12. The test ends with the Cursor Code [ OD99 ].  
YES ↓ NO → Replace the transceiver
13. Remove the Transceiver Terminator Tool. Reconnect the transceiver to the Ethernet and the drop cable to the transceiver. Attempt to run the Ethernet Boot Diagnostics again by selecting the Ethernet Boot Diagnostics Function Key. (F7)

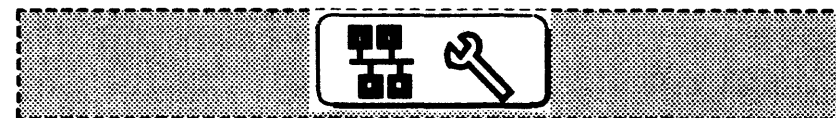

14. The cursor box appears in the middle of the display.  
YES ↓ NO → Go to Step 18



## REPAIR ANALYSIS

---

15. Follow these procedures to verify Ethernet operation:
  - a. When the cursor box is in the middle of the display, press the < STOP > key to prepare the system for test sequence entry.
  - b. Press the < F > key and then the < E > key to boot the Ethernet test File.
  - c. With the Cursor Code at [ OD99 ], press the < S > key and then the < 2 > key to Specify Test Option 2, which is the External Ethernet test option. Press the <Return> key to begin the test.
16. The test completes successfully by stopping at Cursor Code [ OD99 ].  
YES ↓ NO → Go to Step 18
17. Ethernet operation of the workstation has just been verified operational. Proceed to Final Actions.
18. The Ethernet problem is beyond the transceiver. Call for assistance.

### **RAP 7 Floppy Disk Drive Checkout**

1. Perform the Clean Read Write Heads procedure.  
**If Ethernet connection is available:**
  - a. Enter On-Line Diagnostics from either the Logon Sheet or the Desktop.
  - b. Insert a head cleaning diskette from the 5¼ Floppy Drive Head Cleaning Kit (P/N 73P80439).
  - c. Select Run to start the head cleaning routine. After 14 seconds, the routine will stop automatically. Exit On-Line diagnostics and go to Step 2.**If no Ethernet connection is available:**
  - a. Insert a head cleaning diskette from the 5¼ Floppy Drive Head Cleaning Kit (P/N 73P80439).
  - b. Run the floppy drive by selecting the Floppy Boot Function Key (F2). Let the floppy drive run for 14 seconds, then press the < Reset > button to stop the cleaning process. Remove the head cleaning diskette and go to Step 2.

**CAUTION**

The following test is destructive to the data on the floppy disk.

2. Run the the Floppy Format/Read/Write Test by following these procedures:
  - a. Insert a blank floppy diskette that is not write-protected into the floppy disk drive.
  - b. Select the Workstation Diagnostics Boot Function Key.(F5)



- c. When the cursor box is in the middle of the display, press the <STOP> key to prepare the system for test sequence entry.
  - d. Press the < F > key and then the < F > key again to boot the Floppy test File.
  - e. With the Cursor Code at [ OE99 ], press the < S > key and then the < F > key to Specify Test Option E, which is the Format/Read/Write test option. Press the <Return> key to begin the test.

3. In approximately 2 minutes the test completes successfully by stopping at Cursor Code [ OE99 ].  
YES ↓ NO → Go to RAP 12
4. The floppy disk drive has just been verified operational. Problem still exists.  
YES ↓ NO → Go to Final Actions
5. If the problem still occurs when only a specific customer floppy is used, inform the customer that the floppy is likely damaged. If problem occurs with several customer floppies, call for assistance.

**RAP 8 RS-232-C Checkout**

1. Run the RS-232-C Loopback Test by following these procedures:
  - a. Disconnect the RS-232-C interface cable from the DCE or DTE port on the IOP PWBA and connect the RS 232 loopback test cable between the two RS-232-C ports on the IOP PWBA.

## REPAIR ANALYSIS

- b. Select the Workstation Diagnostics Boot Function Key.(F5)



- c. When the cursor box is in the middle of the display, press the <STOP> key to prepare the system for test sequence entry.
- d. Press the < F > key and then the < R > key to boot the RS-232-C test File.
- e. With the Cursor Code at [ OF99 ], press the < S > key and then the < 0 > (zero) key to Specify Test Option 0, which is the all-purpose RS-232-C test option. Press the <Return> key to begin the test.
2. The test completes successfully by stopping at Cursor Code [ OF99 ].  
YES ↓ NO → Go to Step 4
3. The RS-232-C Comm operation has just been verified operational up through the RS-232-C cable. Call for assistance.

4. Replace the IOP PWBA. If the problem is still not corrected, inform the customer to replace the RS-232-C cable.

### RAP 9 Rigid Disk Drive Recovery

1. Insert the Off-Line Rigid Disk Utilities floppy into the floppy disk drive and select the Floppy Boot Function Key (F2). Or select the Off-Line Rigid Disk Utilities from the Ethernet Executive Menu (F3)



Floppy Boot Softkey Ethernet Diag. Boot Softkey

2. After pressing any key to get from the Identification Menu to the logon menu, type a <1> and a <Return> for User.
3. Select Confidence Test by typing a <1> and a <Return>.
4. The Confidence Test passed.  
YES ↓ NO → Go to Step 8

5. Boot the system software from the Rigid Disk. (F1)
6. After approximately 12 minutes the bouncing keyboard is displayed.  
YES ↓ NO → Call for assistance.
7. System is working.
8. If the failure code was a 1, 2, or 3, Replace the IOP PWBA (PL 3.1). If it was any other number, write down the failure number plus any bad page numbers and Call for Assistance.
9. Boot the system software from the Rigid Disk. (F1)
10. After approximately 12 minutes the bouncing keyboard is displayed.  
YES ↓ NO → Call for assistance.
11. System is working.

**RAP 10 Keyboard/Mouse Checkout**

1. Insert the Off-Line Keyboard/Display/Mouse Diagnostics floppy into the floppy disk drive and select the Floppy Boot Function Key (F2). Or select the Off-Line Keyboard/Display/Mouse Diagnostics from the Ethernet Executive Menu . (F3)



Floppy Boot Softkey    Ethernet Diag. Boot Softkey

2. After pressing any key to get from the identification menu to the logon menu, type a <1> and a <Return> for User.
3. In the Test Selection menu, type a < 1 > and a <Return> to select the Keyboard And Mouse Test. All keys and the mouse buttons are shown as white.  
YES ↓ NO → Go to Step 6
4. Press and release any keys or mouse buttons that are suspect. The keys and/or buttons function normally (black when pressed; white when not pressed).  
YES ↓ NO → Go to Step 6

## REPAIR ANALYSIS

5. The keyboard and/or mouse have just been verified operational. Proceed to Final Actions.
6. Check and correct the keyboard and/or mouse for any any obvious problem causes such as dirty, sticky keys, staples, loose connectors, etc. Retest the keyboard and/or mouse. The keyboard and/or mouse function correctly.  
YES ↓ NO → Go to Step 8
7. The keyboard and/or mouse have just been verified operational. Proceed to Final Actions.
8. Replace the keyboard and/or mouse as appropriate.

### **RAP 11** Display Checkout

1. After Pre-Boot Diagnostics completes, the Softkeys appear on the display.  
YES ↓ NO → Step 7
2. Insert the Off-Line Keyboard/Display/Mouse Diagnostics floppy into the floppy disk drive and select the Floppy Boot Function Key (F2). Or select the Off-Line Keyboard/Display/Mouse Diagnostics from the Ethernet Executive Menu. (F3)

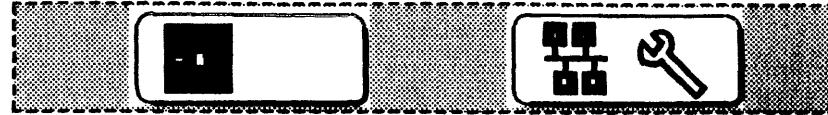

Floppy Boot Softkey . Ethernet Diag. Boot Softkey

3. After pressing any key to get from the identification menu to the logon menu, type a <1> and a <Return> for User.
4. In the Test Selection menu, type a < 4 > and a <Return> to select the Cross-Hair Pattern. The Cross-Hair Pattern on the display is centered and the black borders are approximately equal.  
YES ↓ NO → Replace the display.
5. Overall display image quality is satisfactory.  
YES ↓ NO → If you have been trained on Display adjustments go to Procedure 4.17. Otherwise, call for assistance.
6. Display operation and quality has been verified satisfactory. Proceed to Final Actions.
7. Replace the DCM PWBA. If the problem still exists, replace the display.

**RAP 12 Cursor Codes**

1. The Cursor Code is at the top middle of the display.  
YES ↓ NO → Go to Step 4
2. Press the < R > key to change the Cursor Code into a Report Code. Code changes to Report Code.  
YES ↓ NO → Go to Step 4
3. Replace the components or perform the procedure in the order shown in the cursor box.

Order of component replacement or procedure

1st	2nd
3rd	4th

<b>Code</b>	<b>Procedure</b>
0	Replace the IOP PWBA (4.12)
1	Replace the MPB PWBA (4.14)
2	DCM PWBA - Go to RAP 13

<b>Code</b>	<b>Procedure</b>
3	MEB PWBA - Go to RAP 13
4	Replace the PC0 PWBA
5	Replace the Options PWBA
6	N/A
7	Go to RAP 6
8	Replace the ID Prom (4.16)
9	Go to RAP 9
A	(See NOTE 1 below)
B	N/A
C	N/A
D	N/A
E	<u>N/A</u>
F	Check the cable connections

**NOTE 1:** If not previously performed, go to RAP 7. If RAP 7 was performed, replace Floppy Disk Drive (PL 3-1).

## **REPAIR ANALYSIS**

---

4. For other Cursor Codes and procedures, refer to the specific codes in the following Other Cursor Codes List.

**REPAIR ANALYSIS**

---

<b>Other Cursor Codes List</b>	
<b>Code</b>	<b>Description/Procedure</b>
<b>Code</b>	<b><u>Description/Procedure (?)</u></b>
A400	6085 Display Vertical Event Interrupt
A401	6085 IOP/PCO Map Reg Test
A402	6085 Host Prom Test
A403	(Upstream test)
A404-07	Control Store Constant Data (0000) Test
A408	Control Store Address Data Test
A409	Control Store Random Data Test
A40A	Control Store Bank Test
B500-05	Central Processor Test Routines
B506	Central Processor Real Time Clock Test
B507	Central Processor Memory Interface Test
CA00	Memory Size Check
CA01	Block Data = 0000 (display off, CP, write only, ignore parity error)
CA02-05	Various Block Data Passes (1 pass of each block, display on, CP)

<b>Code</b>	<b><u>Description/Procedure (?)</u></b>
CA06-07	Various Block Data Passes (1 pass of each block, display on, IOP)
CA08	Incrementing Block Data (128 passes)
CA09-0B	Various Address Tests
CA0C-0E	Various Bank Tests



## REPAIR ANALYSIS

### RAP 13 Chip Isolation Procedure

1. The Report Code indicates that the DCM or the MEB PWBA is the first component to replace.  
YES ↓ NO → Return to RAP 12
2. The Report Code is [ 2301 ].  
YES ↓ NO → Go to Step 4.
3. Press < space bar > to return to the Error Code then press < NEXT > to run the next test. When the new Error Code is displayed press < R > to get a Report Code.
4. The Report Code is [ 2310 ] or [ 3210 ]  
YES ↓ NO → Perform Step 3 one more time, then replace the first board as indicated.
5. Press the < space bar > to change the Report Code to a Bank Indicator Code. A Bank Indicator Code is either one number or letter in the lower right position of the cursor box (Example #1), two numbers in the lower positions of the cursor box, or a number and a letter in the lower positions (Example #2).

Example 1

0	0
0	4

Example 2

0	0
1	C

6. Make a note of the Bank Indicator Code. You will use it later in the procedure.
7. Press the < space bar > again to change the Bank Indicator Code to a set of Chip Location Codes. Each number or letter in the cursor box represents a chip or group of chips, and its position in the cursor box is used to find the location of the chips on the board. Make a note of the cursor codes and their locations.
8. Find the reference to the Bank Indicator Code (from Step 6) on Table 2.3 or Table 2.4. All of the other codes you've recorded in this RAP will relate to the chips in the section of the table covered by this Bank Indicator Code.
9. Use the Chip Reference Code List (Table 2.2) to determine the Chip ID Number (or numbers) that corresponds with the number or letter in each position of the cursor box. Make a note of the numbers next to each of the cursor box positions. (Use Example #3 as a guide.)

**Example 3**      8, 4 and 2 }

E	6	{ 2 and 4
0	4	{ 4

10. Use the Chip ID Numbers that you identified in Step 9 to isolate the bad chips within the Bank of chips. The tables are labeled with left, right, upper and lower designations (see Note 1) that relate to cursor box position. Use the Chip ID Numbers and their positions in relation to the cursor box (as shown in Example #3) to interpret the table.

**NOTE 1:** On both Table 2.3 and Table 2.4, the left cursor box and right cursor box designations are on the opposite side of the chart from what you might expect. They were reversed intentionally so that the chips could be shown in the same order in which they appear on the PWBA's.

11. Replace the IC chips as indicated using IC Chip replacement procedure 4.16.

Cursor Digit	Chip ID Numbers
1	1
2	2
3	1 and 2
4	4
5	1 and 4
6	2 and 4
7	1, 2 and 4
8	8
9	1 and 8
A	2 and 8
B	1, 2 and 8
C	4 and 8
D	1, 4 and 8
E	2, 4 and 8
F	1, 2, 4 and 8

Table 2.2 Chip Location Code List

**REPAIR ANALYSIS**

**RIGHT CURSOR DIGIT**

**LEFT CURSOR DIGIT**

**Bank  
Number**

Upper Cursor Digit

<b>U7</b>	<b>U14</b>	<b>U22</b>	<b>U30</b>
1	2	4	8

<b>U38</b>	<b>U46</b>	<b>U54</b>	<b>U62</b>
1	2	4	8

<b>U69</b>
P

**0**

Lower Cursor Digit

<b>U6</b>	<b>U13</b>	<b>U21</b>	<b>U29</b>
1	2	4	8

<b>U37</b>	<b>U45</b>	<b>U53</b>	<b>U61</b>
1	2	4	8

<b>U68</b>
P

Upper Cursor Digit

<b>U4</b>	<b>U11</b>	<b>U19</b>	<b>U27</b>
1	2	4	8

<b>U35</b>	<b>U43</b>	<b>U51</b>	<b>U59</b>
1	2	4	8

<b>U66</b>
P

**4**

Lower Cursor Digit

<b>U3</b>	<b>U10</b>	<b>U18</b>	<b>U26</b>
1	2	4	8

<b>U34</b>	<b>U42</b>	<b>U50</b>	<b>U58</b>
1	2	4	8

<b>U65</b>
P

Upper Cursor Digit

<b>U2</b>	<b>U9</b>	<b>U17</b>	<b>U25</b>
1	2	4	8

<b>U33</b>	<b>U41</b>	<b>U49</b>	<b>U57</b>
1	2	4	8

<b>U64</b>
P

**8**

Lower Cursor Digit

<b>U1</b>	<b>U8</b>	<b>U16</b>	<b>U24</b>
1	2	4	8

<b>U32</b>	<b>U40</b>	<b>U48</b>	<b>U56</b>
1	2	4	8

<b>U63</b>
P

Table 2.3 DCM PWBA Chip Isolation Chart

UPPER CURSOR DIGIT					LOWER CURSOR DIGIT					Bank Number										
U30	U39	U48	U57		U62	U71	U78	U85	U91	U96	U105	U114	U123		U128	U137	U146	U151	U160	1C
1	2	4	8		1	2	4	8	P0	1	2	4	8		1	2	4	8	P1	
U29	U38	U47	U56		U61	U70	U77	U84	U90	U95	U104	U113	U122		U127	U136	U145	U150	U159	18
1	2	4	8		1	2	4	8	P0	1	2	4	8		1	2	4	8	P1	
U28	U37	U46	U55		U60	U69	U76	U83	U89	U94	U103	U112	U121		U126	U135	U144	U149	U158	14
1	2	4	8		1	2	4	8	P0	1	2	4	8		1	2	4	8	P1	
U27	U36	U45	U54		U59	U68	U75	U82	U88	U93	U102	U111	U120		U125	U134	U143	U148	U157	10
1	2	4	8		1	2	4	8	P0	1	2	4	8		1	2	4	8	P1	
U26	U35	U44	U53		U58	U67	U74	U81	U87	U92	U101	U110	U119		U124	U133	U142	U147	U156	C
1	2	4	8		1	2	4	8	P0	1	2	4	8		1	2	4	8	P1	
RIGHT				LEFT					RIGHT				LEFT							

Table 2.4 MEB PWBA Chip Isolation Chart

**ON-LINE DIAGNOSTICS**

On-Line Diagnostics provide peripheral diagnostic programs for testing the Display, Keyboard/Mouse, Floppy Disk Drive, Ethernet (communication interfaces), and RS-232-C. The On-Line Diagnostics are stored on the Rigid Disk, are accessed through operating software, and are menu driven (desired tests are selected from a menu on the display).

**6085 ON-LINE DIAGNOSTICS**

All of the available 6085 On-Line Diagnostics tests are shown on an initial menu. Individual tests are selected from the initial menu, and each test has a separate window for information and procedures. The Command Line is also used for information and procedures. The Echo and RS-232-C tests also have separate property sheet windows that allow the user to set different test parameters for these tests.

**●Display Test**

The Display Test displays six patterns on the Large Format Display (LFD). The first pattern is similar to the cross hairs found in a sighting lens, the second consists of a display

filled with the letter H, the third and fourth consists of a display filled with the @ symbol (one pattern bolded), the fifth consists of a set of parallel lines, and the sixth blank. These patterns enable the user to check the alignment, focus, and intensity of the LFD monitor.

**●Keyboard Test**

In the Keyboard Test, the LFD will contain a picture of a keyboard and a mouse. Pressing any key will highlight the corresponding key in the picture. This test allows the user to verify the operation of the keyboard and mouse.

**●Echo Test (Test for Ethernet Communication Interfaces)**

When this test is selected, the host processor transmits a sequence of packets and expects the remote processor to echo the packets. Each packet has a sequence number which determines the length and contents of the packet by a predetermined algorithm. The size of each packet, the contents of the packet, the rate of sending packets, and the time to wait for each packet to be echoed, are all set to default values - there is no requirement for the user to assign them.

If the ID # supplied for the test partner is the same as that of the host machine, the message *Echo to self is not*

## REPAIR ANALYSIS

---

**allowed** will appear in the command line, and the system will wait for a new number to be entered. If the address for the host or test partner machine is not valid, the message **Network address invalid** will appear until correct address is entered. If the supplied Processor ID is zero, the message **Processor ID is invalid or out of range** will appear in the command line, and the system will wait for a new number to be entered. When the default packet size is not used and the value entered for the packet size is out of range, the message **Packet Size is out of range** will appear.

After sending a packet and before sending the next packet, the host machine waits for its echo from the remote machine or waits a user specified amount of time. After the Echo Test is executed, intermediate results will be displayed approximately every 45 seconds, or, if **Display Real Time Feedback** has been selected, a character will be displayed for every packet transmitted. In either mode the final results are displayed after the **< STOP >** key is pressed.

Without the display per packet, the test is able to operate at maximum speed and thus stress the hardware more effectively. For these reasons this is the recommended mode for running the Echo Test.

When the Real Time Feedback mode is used, different characters indicate the status of the transmission and response. With this mode a Real Time Feedback Key is displayed, which explains the meaning of each of the possible feedback characters.

### ●RS-232-C Test

The RS-232-C Test uses an echo test to test the timing portion and modem associated with an RS-232-C port. The RS-232-C Test generates frames of information that are transmitted through the RS-232-C port. These frames return to the port through a modem placed in an analog loopback mode or a loopback tool. Each frame received is checked for validity of its content, its sequence number, and the condition of the transmitter and receiver loop.

During the test execution one or more of three informational messages about the Data Set Ready (DSR) or the Clear To Send (CTS) signals may appear. The three messages are **Waiting for DSR**, **DSR Signal is now on**, and **CTS signal is now on**. There are two error conditions with accompanying messages that may occur. If there is no RS-232-C hardware installed or in the event of a fatal hardware or software failure, the message **No Hardware** will appear. When a text parameter is entered with an invalid or out-of-range value, the message **Invalid**

**Cancel** will automatically return all fields to their default settings and return you to the test window.

Once a test has been selected, selecting **Run** will start the test. As the test is executed, results (if any) will also appear in this window. At any time during the execution of a test the user may press **< STOP >** and the current test will halt, with applicable results in the test window.

Selecting **Close** returns to the On-Line Diagnostic Menu. Selecting **Close All** returns the workstation to the state it was in before On-Line Diagnostics was invoked.

### ●Display Test

Selecting Display Test from the On-Line Diagnostics menu will bring up the Display Test window, which will give you self-explanatory information and instructions (Figure 2A-2). There is no property sheet associated with this test.

### ●Keyboard Test

As the Keyboard Test window (Figure 2A-3) indicates, user interaction is required and the test is not terminated with the **< STOP >** key. There is no property sheet for this test.

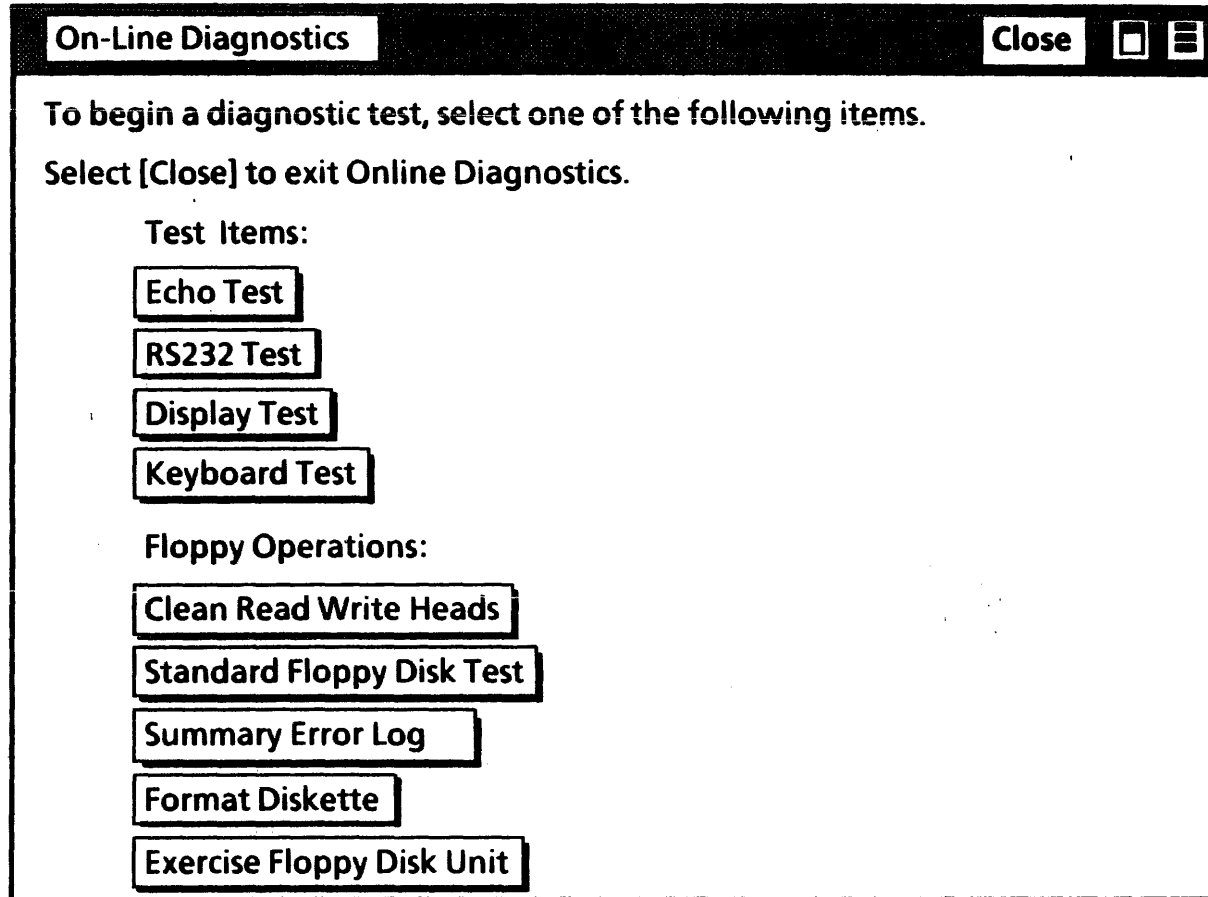

Figure 2A-1 On-Line Diagnostics Menu



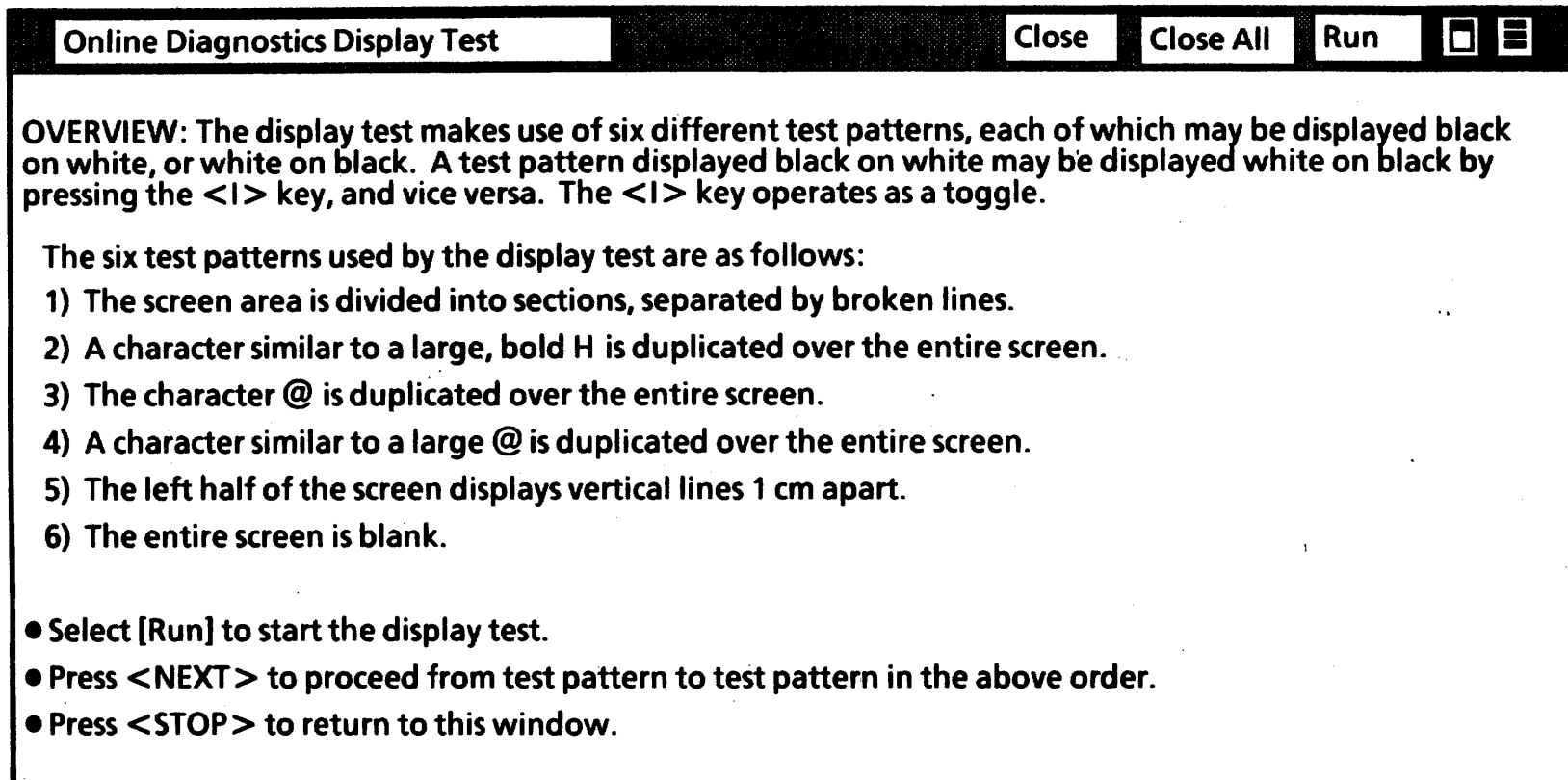
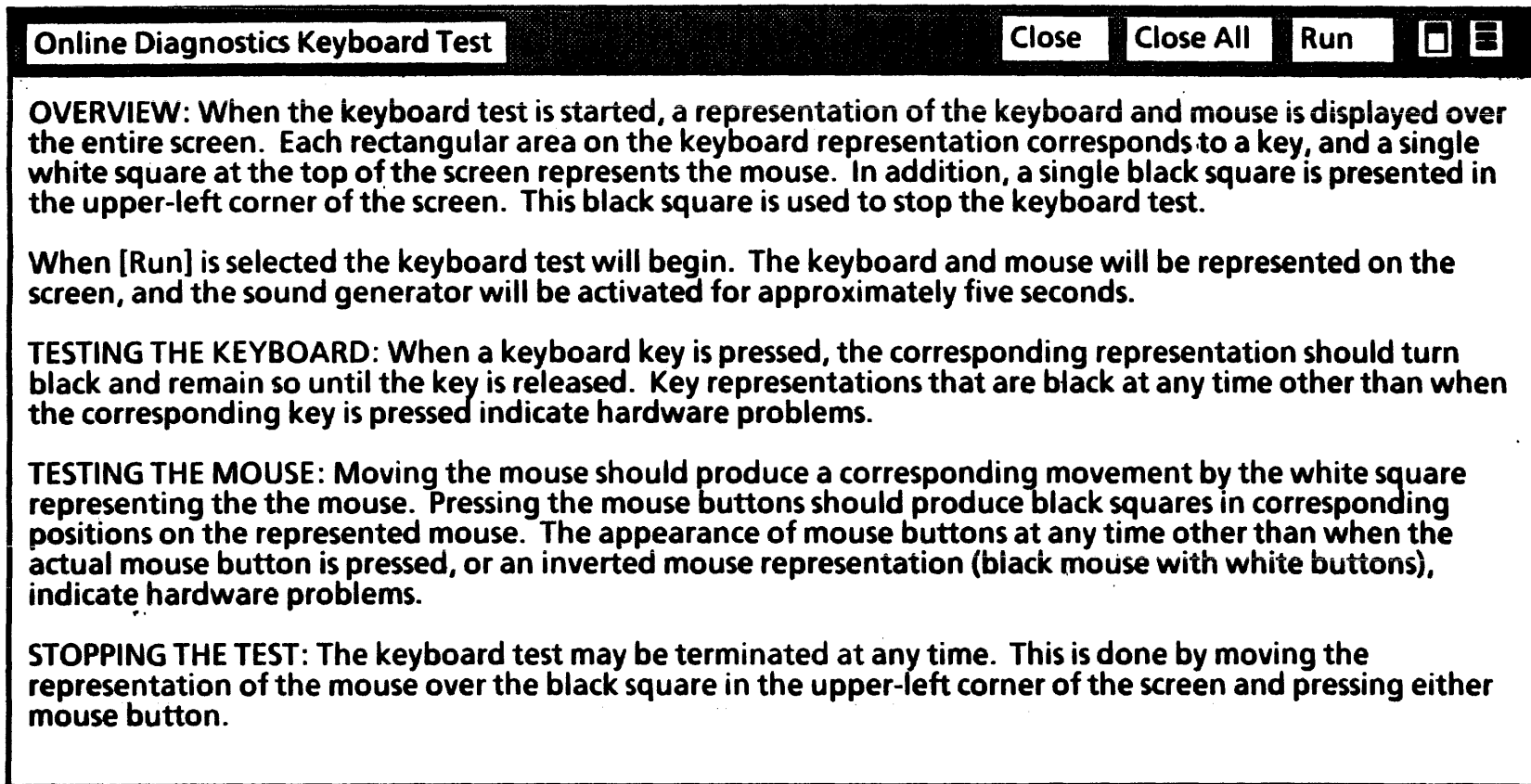

Figure 2A-2 Display Test Window



**Figure 2A-3 Keyboard Test Window**

---

**●Echo Test (Test for Ethernet Communication Interfaces)**

**NOTE:** Before running the Echo Test from a server or workstation to a workstation (6085, 8010 or 860), or from any processor on one net to any processor or 860 on another net, be sure to have the test partner's processor ID number and network number.

When the Echo test is selected, the Echo Test window and its default or current test parameters will be displayed. The test can be run from this point, or the user can change the test parameters by setting new properties in the Echo Test Property Sheet.

The Echo Test Property Sheet is displayed by selecting Echo Test from the main menu and selecting *Show Test Properties* from the Echo Test window. The Echo Test Property Sheet can be scrolled to accommodate instances when all the properties can not be viewed at once. The property sheet for the echo test (shown in Figure 2A-4 with defaults selected) contains the following parameters:

**Current Domain: Organization**

This is a read only parameter (cannot be changed by test user), the value of which is retrieved from local disk storage if present or else is determined by a Clearinghouse function.

**Local network address**

This is a read only parameter displaying the Ethernet and processor IDs of the workstation being used to initiate the test.

**Echo Source**

This is a choice parameter that allows the user to select either the local workstation or a remote workstation to be the source of the transmissions. If *Remote* is selected, the *Echo Source name or address* will appear on the property sheet and an entry will have to be made. (The use of the Remote option is further explained on the next page.)

**Echo Destination name or address**

This is a text parameter, the default value of which is retrieved from local disk storage if present. The user may enter/change it, but, if left blank, the clearinghouse is used. It specifies the network address of the host which will echo back the transmissions of the source processor. Valid network addresses may be a name (e.g. Tundra) or decimal (0-060.2A-652-126-818), octal (74.25200000142B), or hex (3C.AA000062X) number. If the local name only is specified (i.e. Tundra), then the organization and domain values used to find this machine are those

## REPAIR ANALYSIS

---

which appear after **Current Domain:Organization** on the option sheet.

### Display Real Time Feedback

This is a choice parameter selected only if the user selected **Local** as the **Echo Source**. If **Yes** is selected a single character will be displayed for each packet transmitted, indicating the status of the transmission and response. If **No** (the default) is selected there will be no display per packet. However, the Intermediate results will continue to be displayed. This default option will allow the test to operate at maximum speed and thus stress the hardware more effectively.

### Set Data Pattern

This is a choice parameter, giving the user control over the data used in the Echo Test. The choices are all ones, all zeros, random or incrementing (the default) or constant.

### Packet Size

This is a pair of text parameters to allow user control over the packet size. If a fixed packet size is desired, the **Minimum Packet Size** and **Maximum Packet Size** should both be set to the desired size. Otherwise the

packet size will vary (incrementing from minimum to maximum) between the two values.

### Wait for response before sending next packet and Delay between packets

By default, the test will wait for response to the previous packet before sending the next. However, the user may override this (by selecting **No** for this parameter) and specify a fixed delay between packets via the **Delay between packets** parameter (which has a default value of 100 milliseconds).

### Display Server List

This choice parameter allows the user to view the servers available in the **Current Domain:Organization**. The list will be displayed in the Echo Test Property Sheet. The default is that NO server list is displayed.

Upon selecting **Run** the Echo Test is executed. Test results are displayed in the Echo Test window. Approximately every 45 seconds, intermediate results will be displayed in the Echo Test window or, if **Display Real Time Feedback** has been selected, a character will be displayed for every packet expected. Figure 2A-4 shows a test session after being stopped that had **Yes** selected for **Display Real Time Feedback**. At this point the user may **Close** the test

or re-**Run** the test with or without altering test properties. Every time **Run** is selected, the current test parameters and feedback key (if **Real Time Feedback** is **Yes**) will be displayed.

To stop the test before the entire window is filled, press the < **STOP** > key.

Once the window is filled with the echoed packet responses or intermediate test results, the screen will scroll up. If the test parameters are not visible when the test is stopped, **Show Test Properties** can be selected to observe the current test parameters.

By selecting **Remote** for the **Echo Source** in the test property sheet, the user can direct an Echo test that will take place between any two machines on the connected internet. This facility can be used to narrow problems to a specific internetwork link, or to test the communication path between two machines that are distant from each other in a controlled, step-by-step manner.

Three processors are involved in a remote echo test. The first is the test initiator, which is the processor from which the user issues the Echo commands. The test initiator sends commands to the second machine used.

The second machine, which must always be a server, is the remote system. The remote system sends out echo requests to the third machine which is also specified in the test command. The third machine used is the test partner. The test partner responds to the remote system, which keeps statistics on the number of packets echoed successfully, the number of packets that were not echoed, and the number that were echoed back later than expected. Workstations, servers, and networked 860s can be used as test partners. CIUs cannot be used as test partners.

There is no time limit on a remote echo test. Only one echo test, either local or remote, can be controlled by a server at a time, and a server can function as an remote system for only one test initiator at a time. A server functions as an remote system, under control of a remote test initiator, completely transparent to the services or users of the server.

The message **Remote echo could not be successfully executed** is displayed if the test initiator server cannot successfully command the remote system to start the test because the remote system could not be contacted or was already in use for a different test initiator. A high level communication protocol is used to communicate between the test initiator and the remote system. The

## **REPAIR ANALYSIS**



---

remote system should be "closer" on the internet to the test initiator than the test partner (test partner). Control and command messages are passed between the test initiator and the remote system. The remote system should be on the same "side" of the internet connection under test as the test initiator to ensure that the command and control message traffic does not interfere with the test data traffic.

Figure 2A-4 illustrates what an Echo Test window would look like after completing a test that used the Local Echo Source and the Display Real Time Feedback options. Figure 2A-5 is graphic reference of the Echo Test Property Sheet with additional explanation shown as (comment).



REPAIR ANALYSIS

**Echo Test Property Sheet** Done Cancel  

Current Domain: Organization = OSBU North:Xerox

Local Network address = 0-060.2-852-129-141 =  
1233.25200064162.0 =  
29AH.0AA00743AH.OH

Echo Source =  Local  Remote

Echo Source name or address =  (remote only)

Echo Destination name or address =

Real Time Feedback  Yes  No (local only)

Data Pattern :  Incrementing  All 0's  All 1's  Constant

Minimum Packet size:  (2 - 512 bytes)

Maximum Packet Size:  (2 - 512 bytes)

Wait for response before sending next packet:  Yes  No

Delay between packets (milliseconds)  (only if NO wait for response)

Display Server List  Yes  No

Figure 2A-5 Echo Test Property Sheet



---

- **RS-232-C Test**

The RS-232-C test is designed to test the function and performance (reliability) of the RS-232-C interface on a workstation. Various options are available for the user to control the test. The Property sheet for the RS-232-C test (shown in Figure 2A-6 with defaults selected) will allow the user to set up the following parameters:

**Mode**

This is a choice parameter, the default being *Bit Synchronous*.

**Data Rate**

This is a choice parameter, the default value is *1200*. (This parameter only appears when *Asynchronous* mode is selected.)

**Set Data Pattern**

This is a primarily a choice parameter, allowing the user control over the data used in the loopback test. The pattern may be *Incrementing* (the default), a *Constant, All 0's* or *All 1's*. If *Constant* is chosen then the user may enter the desired value in the associated text parameter. The value must be in the range 0 to 255 inclusive and will be 0 if left blank.

**Set Packet Size**

This is a pair of text parameters to allow user control over the packet size. If a fixed packet size is desired, the "Minimum Packet Size" and "Maximum Packet Size" should both be set to the desired size. Otherwise the packet size will vary (incrementing from minimum to maximum) between the two values. Packet sizes do not apply to an asynchronous test.

The selection and running of the RS-232-C test is very similar to the Echo test. The running of the RS-232-C Test requires either the installation of the Universal Loopback Tool (600T1656) on the RS-232-C port of the workstation or setting the modem or modem eliminator to loopback mode. If bit-synchronous mode is chosen, an external clock source is also required. Upon selecting *Run* the RS-232-C Test is executed. As the test is executed intermediate results will appear in the RS-232-C Test window approximately every 45 seconds. Figure 2-9 shows a test session after being stopped additional explanation shown as (comment). At this point the user may *Close* the test or re-*Run* the test with or without altering test properties. Each time *Run* is selected the current test parameters will be repainted in the window.

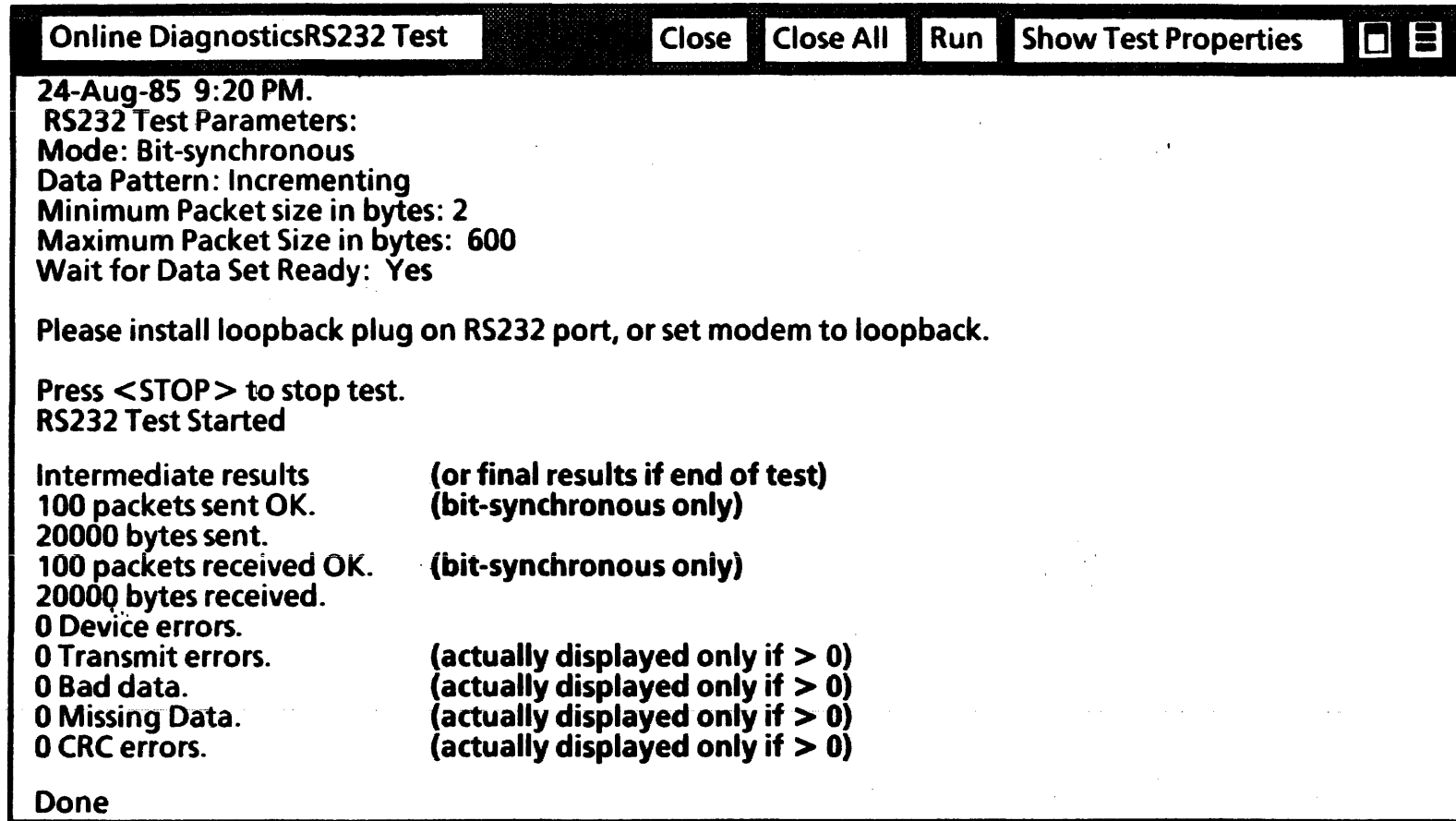

Figure 2A-6 RS-232-C Test Window

RS232 Test Property Sheet Done Cancel □ ☰

Mode  Asynchronous  Bit Synchronous

Data Pattern  Incrementing  All 0's  All 1's  Constant

Minimum Packet Size:  (2 - 600 bytes)

Maximum Packet Size:  (2 - 600 bytes)

Wait For Data Set Ready:  No  Yes

Figure 2A-7 RS-232-C Property Sheet

## REPAIR ANALYSIS

---

### ●Floppy Operations

To run a floppy test or operation from the 6085 PCS, select the desired test or operation under *Floppy Operations* on the main On-Line Diagnostics menu. A window for the selected test or operation will then appear. Follow the applicable display messages to run selected tests. Only the Floppy Command File Test has a property sheet.



**Clean Read Write Head** is an operational maintenance utility that is used periodically to assure functional integrity of the floppy disk drive. Note that a special head cleaning diskette must be used and, be sure to wait until the display asks for the cleaning disk before applying the solution to the disk. The window and command line give the user simple, self-explanatory directions for using this utility.

**Standard Floppy Disk Test** is a general test of the floppy disk drive and requires a diagnostic floppy diskette as indicated in the Standard Floppy Disk Test window (Figure 2A-8) that appears. The test is designed to begin with NO diskette in the drive. The user will be requested to insert the diskette when appropriate and select **Confirm** in the system message area. If an incorrect diagnostic disk is used or a irrecoverable error condition

exists then the message *Error has occurred; Please call the CSC; tell them the maintenance-panel code* is displayed in the system message area. The MP code indicates the nature of the fault.

When the test is done, an error log (Summary Error Log) is displayed summarizing the test results.

**Summary Error Log** is a separate command that can be selected from the main menu to display the results (a Summary Error Log) of the most recent execution of the Standard Floppy Disk Test or the Exercise Floppy Disk Unit procedure. It is shown as a matrix of the number and type of test/exercise commands executed with the statuses that occurred for each command executed. The type of commands is represented by the top horizontal line of column headings (i.e., Read Status, Recalibrate, etc.). The number of times each kind of command is executed is represented by the TIMES EXECUTED horizontal line. The status and errors are listed vertically in the left column (i.e., Good Completion, Ready, Busy, etc.) with the numbers of times that each occurred correspondingly listed under the command headings.

Online Diagnostics Standard Floppy Disk Test Close Close All Run  

A diagnostic floppy diskette will be needed for this test.  
 Select [Run] to begin the test.

Please insert the Boot Diagnostics floppy disk.  
 Note: Any other diskette will cause erroneous results.  
 Please select CONFIRM when this is done.

**SUMMARY ERROR LOG**

1 = Read Status  
 2 = Recalibrate  
 3 = Read Header  
 4 = Read Sector  
 5 = Write Sectors  
 6 = Write Deleted Sectors

1	2	3	4	5	6	
4	1	1	63	14	1	TIMES EXECUTED
3	1	1	63	14	1	Good Completion
3	1	1	63	14	1	Ready
0	0	0	0	0	0	Busy
0	0	0	0	0	0	Track 00
3	1	1	63	14	1	Double Sided
0	0	0	0	0	0	Write Protected
0	0	0	0	0	0	Disk Changed
0	0	0	0	0	0	Deleted Sector
1	0	0	0	0	0	Error Detected
0	0	0	0	0	0	Recalibrate Error
0	0	0	0	0	0	Seek Error
0	0	0	0	0	0	CRC Error
0	0	0	0	0	0	Incorrect Length
0	0	0	0	0	0	Illegal Status
0	0	0	0	0	0	Sector Count Error

No Error was found.....Done.

Figure 2A-8 Standard Floppy Disk Test Window

## REPAIR ANALYSIS

---

The **Exercise Floppy** routine thoroughly exercises the floppy disk unit, randomly reading and writing random data and verifying it. A formatted diskette is required, and that diskette should be a blank one that is created by using the **Format Diskette** utility. To protect against accidental destruction of information, the user is required to confirm the decision to run this routine by twice having to select **Confirm** in the system message area. If the user decides not to use the diskette he/she may select **Cancel** in the system message area, change diskettes and select **Run** again.

The window and user interface for the **Exercise Floppy** routine is very similar to **Standard Floppy Disk Test**. If an irrecoverable error occurs, the exerciser stops with the message **A hard error has occurred. Check the MP code and the Error Summary Log.**

The **Format Diskette** utility can be used to format a diskette with the standard Xerox format. Such diskette may then be used to run the **Exercise Floppy** procedure or the command file test. To protect against accidental destruction of information, the user is required to twice confirm the decision to run this utility as with the **Exercise Floppy** routine above.

The window and command line give the user simple, self-explanatory directions for using this utility. If formatting fails due to an irrecoverable error, the following message is reported in the **Format Diskette** window: **Bad Track n. The diskette is bad and can't be used.**

**CHAPTER 3 PARTS IDENTIFICATION**  
**6085 Product Support Manual**

**3**

## PARTS IDENTIFICATION

### PL 3.1 PROCESSOR

PART ITEM	NUMBER	PART NAME (DESCRIPTION)
1	121S02230	10MB Rigid Disk Drive Assembly
--	121S02231	20MB Rigid Disk Drive Assembly
--	121S02232	40MB Rigid Disk Drive Assembly
--	121S02233	80MB Rigid Disk Drive Assembly
2	105K00230	Power Supply
3	140K00800	DCM PWBA (Base Configuration only)
4	140K02220	MPB PWBA
5	140K03980	MEB PWBA (Optional)
6	140K00793	IOP PWBA
7	140K01010	PCE PWBA (Optional)
8	140K02351	Backplane PWBA
9	127S02603	Fan Assembly
10	121K00150	360KB Floppy Disk Drive Assembly
11	601K60050	64K Chip Repair Kit (DCM)
12	601K60060	256K Chip Repair Kit (DCM/MEB)
13	601K60070	64K Chip Repair Kit (MPB)
14	152S03449	Power Cord (USO/XC ONLY)
15	9R88356	Floppy Disk Drive Cable (Standard Length)
	152K02640	(Optional Length)
16	99E1570	10 Amp Fuse (pkg. of 5)

17	2E04750	Cover, Side
18	2K02120	Cover, Front
19	2P17741	Cover, Top
20	2K02140	Cover, Bottom Rear (Note 1)
21	120K00080	Cable Retaining Clamp (Note 1)
22	2E07170	Door, Rear
23	19P04858	Clip, Floppy
24	17E00690	Foot, Chassis

**Note 1:** The Bottom Rear Cover and the Cable Retaining Clamp must both be ordered if the entire Cable Retainer Assembly must be replaced.

Removal and Replacement 4.1, 4.2, 4.3, 4.4, 4.5, 4.6, 4.7, 4.10, 4.11, 4.15

Removal, Replacement and Adjustment 4.8 & 4.9



**PARTS IDENTIFICATION**

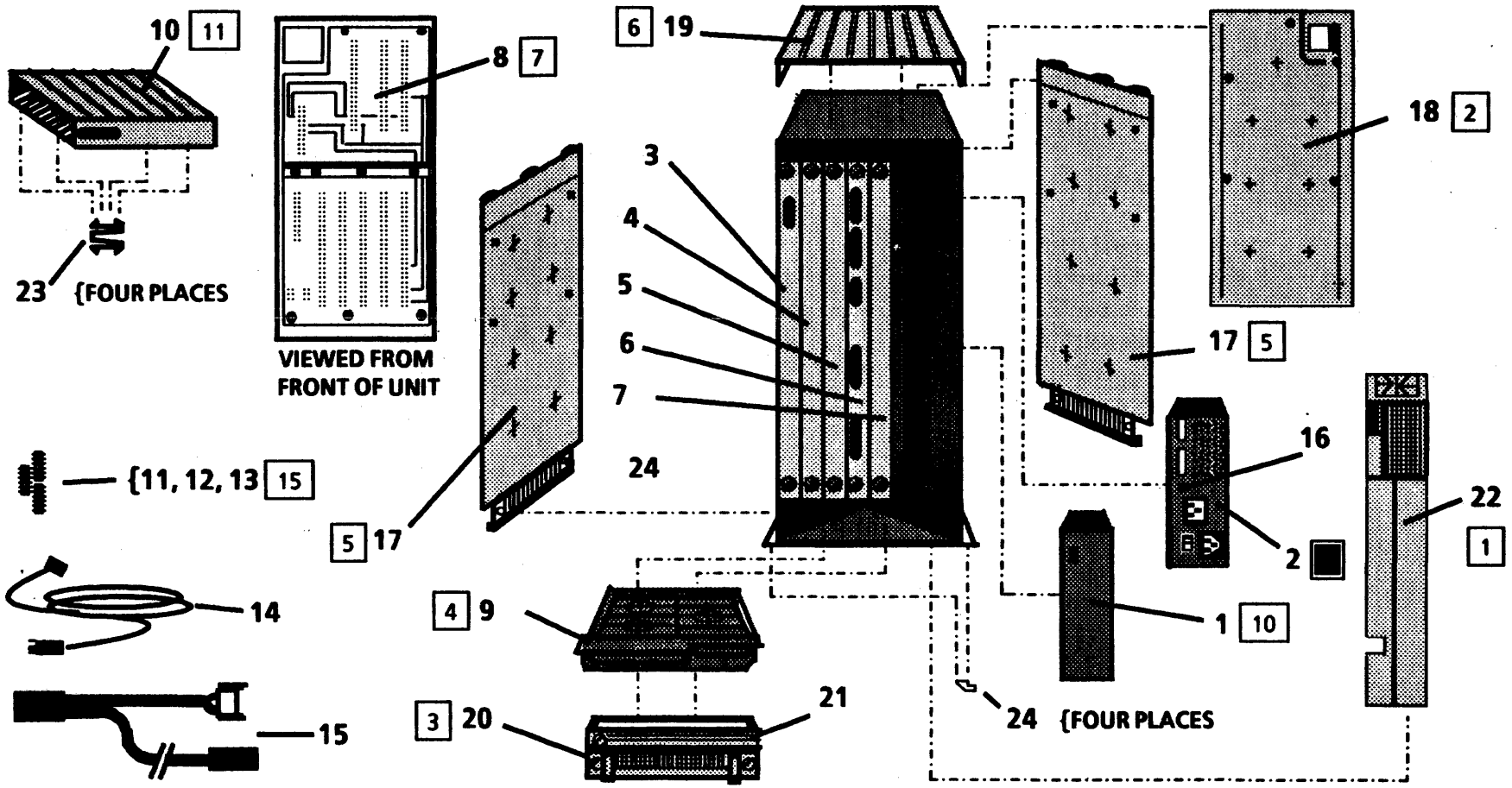

**Figure 3.1 Processor - Rear View**

**PARTS IDENTIFICATION**

**PL 3.2 DISPLAY/KEYBOARD/MOUSE**

<b>PART ITEM</b>	<b>NUMBER</b>	<b>PART NAME (DESCRIPTION)</b>
1	123K00030	15 Inch Display
2	--TBA--	19 Inch Display
3	18K00170	Optical Mouse and Cable
4	110K00080	Keyboard Assembly (US)
	110K00090	Keyboard Assembly (RX)
	110K00100	Keyboard Assembly (FX)
5	--	Keyboard Cable (P/O item 4)

**RX ONLY**

--	73K01320	Keycap Kit (DEN)
--	73K01330	Keycap Kit (UK)
--	73K01340	Keycap Kit (SWE)
--	73K10350	Keycap Kit (SPA)
--	73K01360	Keycap Kit (NOR)
--	73K01370	Keycap Kit (ITA)
--	73K01380	Keycap Kit (GER)
--	73K01390	Keycap Kit (FRA)
--	73K01400	Keycap Kit (FIN)

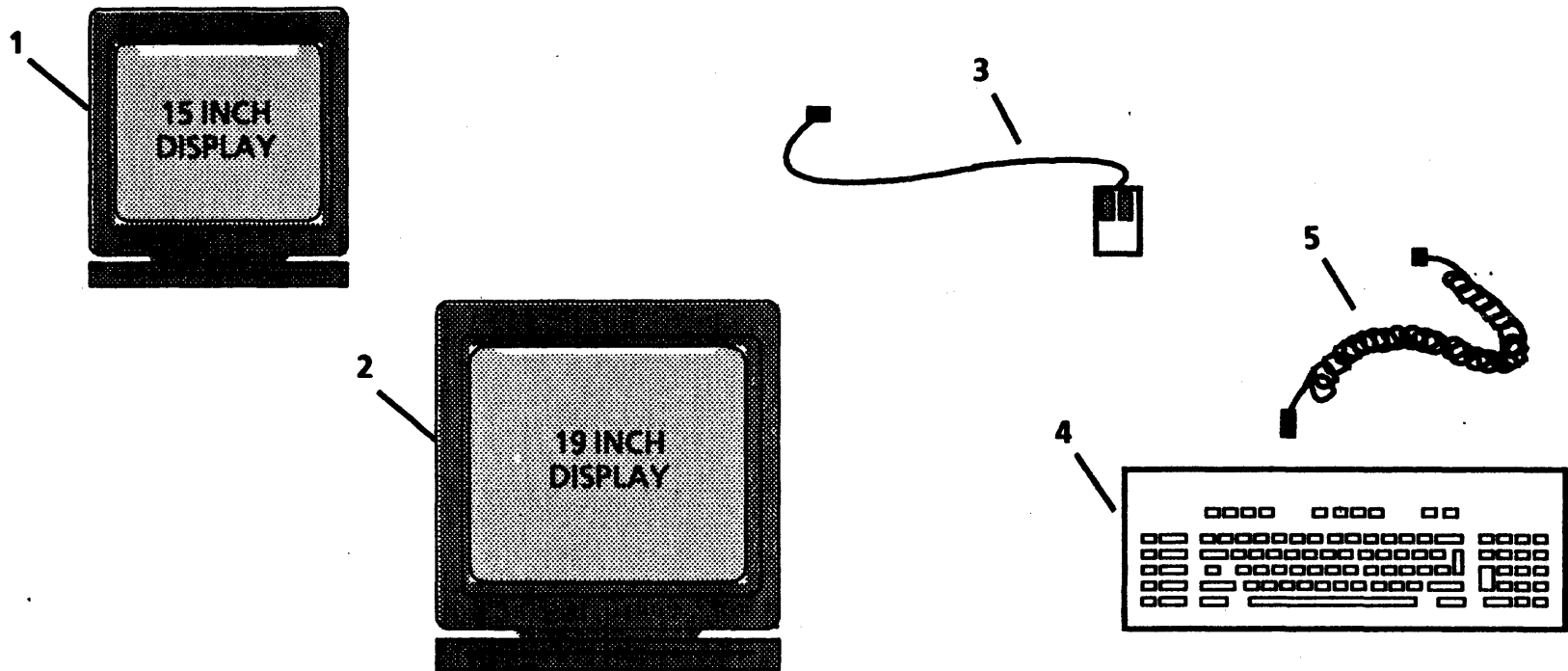

Figure 3-2 Display/Keyboard/Mouse

**CHAPTER 4 REPAIR DATA**  
**6085 Product Support Manual**

**4**

## REPAIR DATA

---

### INDEX

4.1	Rear Cover.....	4-3
4.2	Front Cover .....	4-4
4.3	Cable Retainer Assembly .....	4-4
4.4	Fan Assembly .....	4-5
4.5	Side Covers.....	4-5
4.6	Top Cover.....	4-7
4.7	Backplane .....	4-8
4.8	Power Supply.....	4-9
4.9	+ 5 VDC Check .....	4-10
4.10	Rigid Disk.....	4-11
4.11	Floppy Disk Drive .....	4-14
4.12	IOP PWBA.....	4-14
4.13	Boot PROMS.....	4-16
4.14	MEB PWBA Memory Chips .....	4-18
4.15	MPB PWBA.....	4-20
4.16	IC Chips.....	4-22
4.17	15" Display Cover .....	4-25
4.18	15" Display Shield.....	4-26
4.19	15" Display Image Adjustments .....	4-26

**4.1 REAR COVER****REMOVAL**

1. Switch off the system power.
2. Access the back of the processor.
3. Press the two rear cover tabs towards each other to release the cover. (Figure 4-1)
4. Swing the rear cover down and disengage the power cords from the opening in the cover.

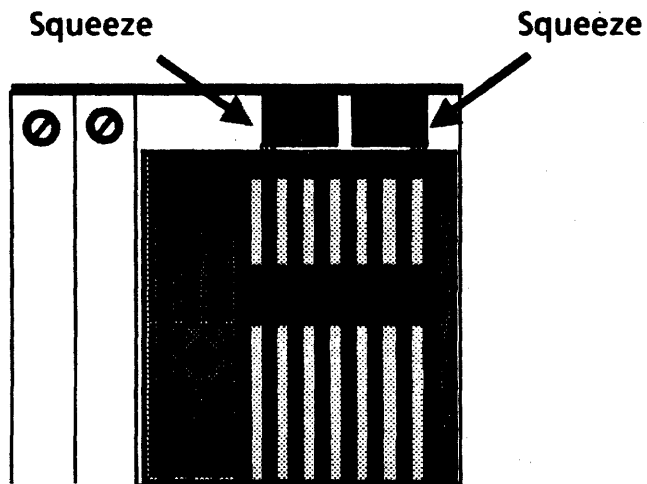

Figure 4-1 Unlatching the Rear Cover

5. Remove the rear cover. (Figure 4-2)
  - a. While holding the cover to the right, squeeze the flange near the power cord slot to the right to release the left plastic stud from the detent.
  - b. Twist the left cover stud up and out of the detent, then release the right cover stud.

**REPLACEMENT**

1. Perform the removal procedure in the reverse order.

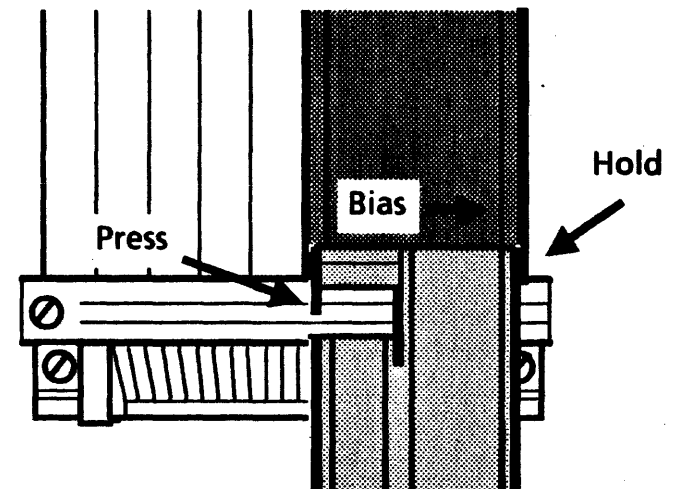

Figure 4-2 Rear Cover Removal

## REPAIR DATA

### 4.2 FRONT COVER

#### REMOVAL

1. Switch off the system power.
2. Access the back of the processor.
3. Remove the Rear Cover. (4.1)
4. Unplug the AC and display power cords.
5. Unplug the floppy disk drive power cord if there is one.
6. Unscrew the power supply retaining screw and back the supply out of the processor about 1 inch.
7. Rotate the processor to access the front.
8. Remove the front cover.
  - a. Remove the two screws at the base of the front panel.
  - b. Remove the front cover by sliding the cover up and then toward yourself.

#### REPLACEMENT

1. Reinstall the front cover.
  - a. Place the front cover against the processor, slightly above the normal position.
  - b. Press the cover against the processor and slide it down into place so that the five brass cover studs lock into the processor brackets.
2. Perform the removal procedure in the reverse order, starting with Step 8a.

### 4.3 CABLE RETAINER ASSEMBLY

#### REMOVAL

1. Switch off the system power.
2. Access the back of the processor.
3. Release the cables and power cords.
  - a. Unscrew the cable retaining clamp screw (Figure 4-3) and swing the clamp away from the processor to free the cables.

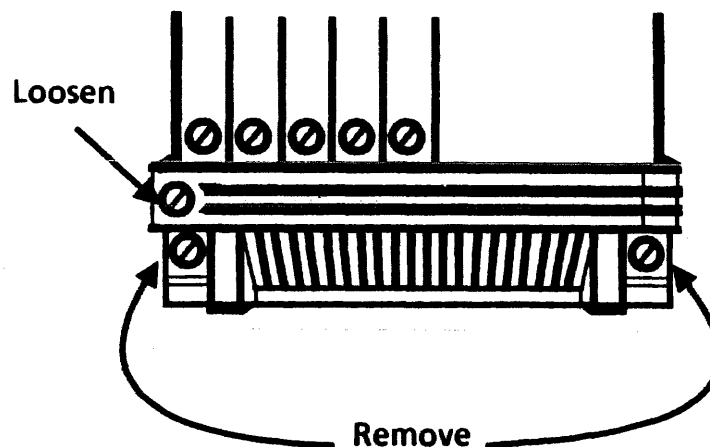

Figure 4-3 Cable Retainer Assembly

4. Remove the cable retainer assembly.
  - a. Unscrew the two screws (Figure 4-3) and remove the retainer.
5. If it is necessary to replace the cable retaining clamp, remove it from the bottom rear cover by grasping the clamp firmly while holding the cover and twisting the clamp flanges out of the detents.

**REPLACEMENT**

1. Perform the removal procedure in the reverse order.

**4.4 FAN ASSEMBLY****REMOVAL**

1. Switch off the system power.
2. Access the back of the processor.
3. Remove the cable retainer assembly. (4.3)
4. Remove the fan assembly (Figure 4-4).
  - a. Pull the fans out by grasping the metal lip of the assembly and pulling firmly towards you.

**REPLACEMENT**

1. Insert the fan assembly so that it rests on top of the flanges in the processor base.

2. Gently slide the assembly into the processor, making certain that the electrical connector mates properly.
3. Perform the removal procedure in the reverse order.

**4.5 SIDE COVERS****REMOVAL**

1. Switch off the system power.
2. Access the back of the processor.

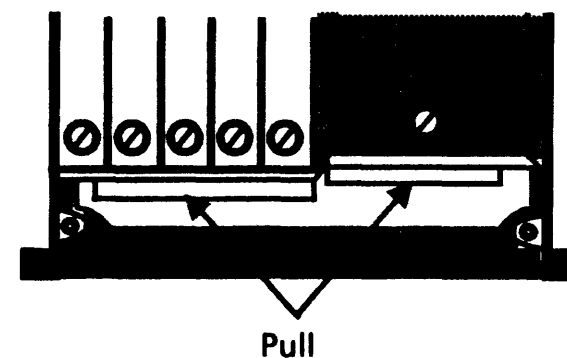

Figure 4-4 Fan Assembly



## REPAIR DATA

3. Remove the Rear Cover. (4.1)
4. Unplug the AC and display power cords.
5. Unplug the floppy disk drive power cord if there is one and remove the floppy disk drive from the top of the processor.
6. Unscrew the power supply retaining screw and back the supply out of the processor about 1 inch.
7. Rotate the processor to access the front.
8. Remove the Front Cover. (4.2)
9. Remove the side cover.
  - a. Remove the two screws.
  - b. Lift the side cover up and then out.
  - c. Repeat for other side.

## REPLACEMENT

**NOTE:** In some cases it may be necessary to remove the top cover in order to replace the side covers. If this is the case, grasp the top cover by the edge on a side of the processor without a cover and lift towards the other side, then proceed to Step 1c.

1. Reinstall the side covers.
  - a. Hold the bottom of the side cover away from the processor and slide the top edge up under the top cover.

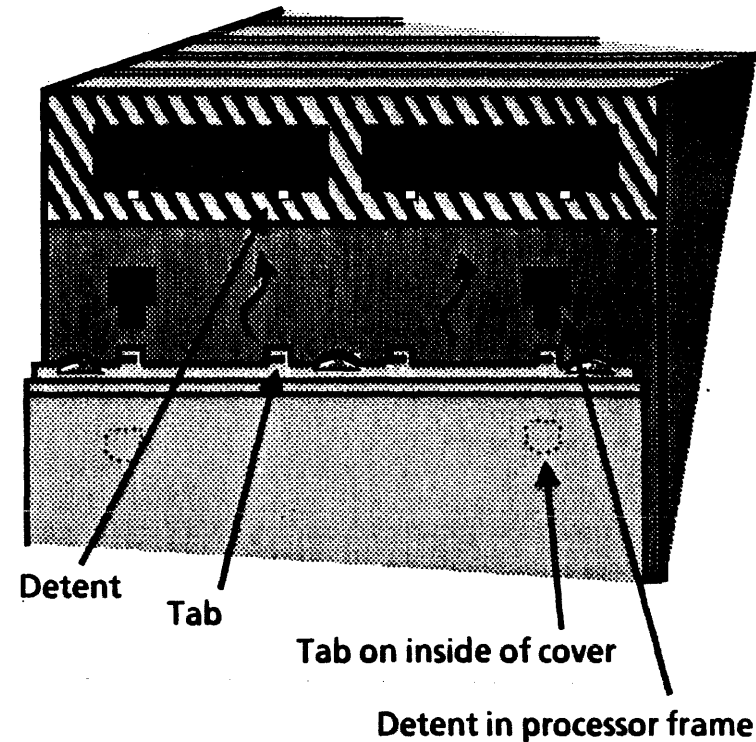

Figure 4-5 Side Cover Installation

- b. Mate the four tabs on the upper edge of the side cover with the four detents in the top cover. (Figure 4-5)
  - c. Bring the bottom of the side cover in flush with the processor side.
  - d. Pressing lightly against the side cover, slide it downward until the four plastic tabs on the inside of the cover slide into the detents on the processor.
  - e. (If the top cover has been removed in order to install the side cover, place it on the processor and allow it to settle into place.) Ensure that the top cover is seated correctly by pressing down firmly along the top edges until the cover detents snap securely onto the side cover tabs. (Figure 4-5)
2. Perform the removal procedure in the reverse order starting with Step 9a.

#### **4.6 TOP COVER**

##### **REMOVAL**

1. Switch off the system power.
2. Access the back of the processor.

3. Remove the Rear Cover. (4.1)
4. Unplug the AC and display power cords.
5. If there is a floppy disk drive present, unplug the power cord. If the floppy disk drive is mounted on top of the processor, remove it.
6. Unscrew the power supply retaining screw and back the supply out of the processor about 1 inch.
7. Rotate the processor to access the front.
8. Remove the Front Cover. (4.2)
9. Remove one Side Cover. (4.5)
10. Remove the top cover.
  - a. Grasp the top cover by the edge on a side of the machine where a side cover was removed and lift it towards the other side of the processor.

##### **REPLACEMENT**

1. Place the top cover on the processor and allow it to settle in place. Press down firmly along the top edges until the cover detents snap securely onto the side cover tabs. (Figure 4-5).
2. To complete the processor cover installation, perform the removal procedure in the reverse order.

**REPAIR DATA**

**4.7 BACKPLANE ASSEMBLY**

**REMOVAL**

1. Switch off the system power.
2. Access the back of the processor.
3. Remove the Rear Cover. (4.1)
4. Release the cable retaining clamp. (4.3)
5. Unplug the AC and display power cords, the floppy disk drive power cord if there is one, and all cables to the PWBA's.
6. Remove the rigid disk drive from the processor.
7. Reach into cavity where the rigid disk drive was removed and unplug the fan assembly power cord from the backplane.
8. Unscrew the power supply retaining screw and back the supply out of the processor about 1 inch.
9. Back the PWBA's out of the processor about 1 inch.
10. Rotate the processor to access the front.
11. Remove the Front Cover. (4.2)
12. Remove the backplane.
  - a. Remove the eight screws as shown in Figure 4-6 while leaving the screw in the center.
  - b. Lift out the backplane.

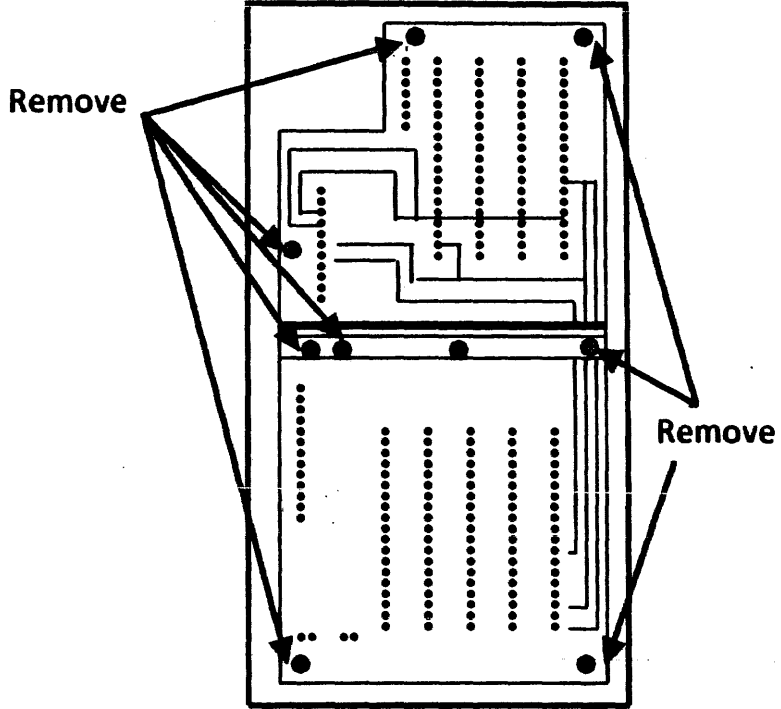

Figure 4-6 Backplane

**REPLACEMENT**

1. Perform the removal procedure in the reverse order, taking care to start all eight of the screws before tightening any of them.

**4.8 POWER SUPPLY****REMOVAL**

1. Switch off the system power.
2. Access the back of the processor.
3. Remove the Rear Cover. (4.1)
4. Unplug the AC and display power cords.
5. Unplug the floppy disk drive power cord if there is one.

**WARNING**

High voltages are present in the power supply for 2 minutes after the AC power cord has been disconnected from the wall outlet. **DO NOT REMOVE THE POWER SUPPLY COVER.** There are no serviceable parts inside the Power Supply.

6. Unscrew the power supply retaining screw.
7. Remove the power supply.

**REPLACEMENT**

1. Perform the removal procedure in the reverse order while taking care to properly align the PWBA of the power supply in the top and bottom guide slots during installation.
2. Perform the +5VDC Check. (4.9)

## REPAIR DATA

### 4.9 + 5 VDC CHECK

1. Select the +20 volt DC scale on the digital multimeter (600T1616).
2. Connect the meter leads to the test points as shown in Figure 4-7. It is not necessary to remove the rear cover to perform this check.
3. If the reading obtained is between + 5.15 VDC and + 5.25 VDC, it is within specifications and no adjustment is necessary.
4. If the reading is not correct, adjust the + 5 VDC by turning the adjustment pot clockwise to raise the voltage or counterclockwise to lower the voltage. The resulting reading should be + 5.2 VDC.
5. If the correct reading cannot be obtained by adjusting the pot, go to RAP 1.

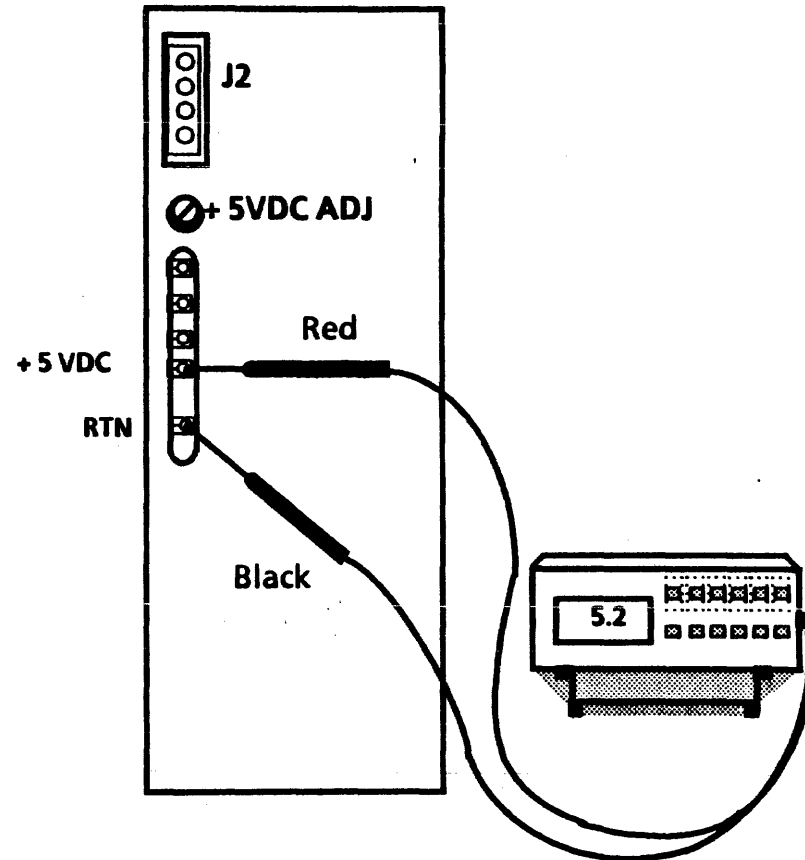

Figure 4-7 + 5VDC Check

**4.10 RIGID DISK****REMOVAL****CAUTION**

Replacement of the Rigid Disk Drive deletes customer files. This requires the restoration of files by the customer. **BEFORE** replacing the Drive, call for assistance; then notify the customer's System Administrator or Network Coordinator. The customer **MUST** be notified **BEFORE** the Rigid Disk Drive is replaced. It is possible that the Systems Analyst will know a work-around procedure, and the Drive will not need to be replaced. If the customer will not agree to have their Drive replaced, contact the Systems Analyst for further instructions. **NEVER REPLACE A DISK DRIVE WITHOUT FIRST NOTIFYING BOTH THE CUSTOMER AND THE SYSTEMS ANALYST.**

1. Switch off the system power.
2. Access the back of the processor.
3. Remove the Rear Cover. (4.1)
4. Unplug the AC and display power cords.
5. Unscrew the disk drive retaining screw.
6. Slide the rigid disk drive out of the processor.

**REPLACEMENT**

**NOTE:** Before installing the new Disk Drive, copy or record the vendors bad page table.

1. Perform the removal procedure in the reverse order, taking care not to dislodge the fan wiring harness connector from the backplane.
2. There is a Xerox error map (bad page table) with the new Rigid Disk Drive.  
YES ↓      NO → Go to step 9

**NOTE:** If you cannot boot the configuration utility, it may be because the configuration is set wrong. You can get around this problem by pressing and holding function key (F9) during the boot sequence.

3. Check the system configuration using the System Configuration Utility. The configuration is set properly. Refer to (Table 4-1 for Rigid Disk Model numbers).  
YES ↓      NO → Set system configuration. (6.1.13)
4. Run Boot Diagnostics from the floppy by selecting Function Key (F6). Boot Diagnostics completed successfully and the boot softkeys are displayed.

## REPAIR DATA

---

**YES ↓**    **NO →** Go to MP codes list. (Ch 2)

**NOTE:** The following procedures are used with the Rigid Disk Diagnostics Floppy or Rigid Disk Utilities from the net.

5. Run Confidence Test using Rigid Disk Diagnostics. (2 passes) Confidence Test passed.  
**YES ↓**    **NO →** Record bad pages on any 2 out of 10 tries that are bad. Any other failure see MP codes list.
6. Run Verify Disk Surface. (5 passes) Record any bad pages.
7. The bad pages on the Xerox error map are the same as the ones found in steps 5 and 6 in the bad page table.  
**YES ↓**    **NO →** Manually enter bad bad pages. Go to step 12.
8. Ask the system administrator to Install software. Boot the software. Go to Final Actions.

**NOTE:** If you cannot boot the configuration utility, it may be because the configuration is set wrong. You can get

around this problem by pressing and holding function key (F9) during the boot sequence.

9. Check configuration. Configuration is correct.  
**YES ↓**    **NO →** Set configuration. (6.1.13) (Refer to Table 4-1 for Rigid Disk Model number). Go to step 10.
10. Install the Rigid Disk Diagnostics floppy and press Function Key (F2).
  - Select 3, Tech Support. enter password (REXIFSN)
  - Select New Disk Checkout. (5 passes) Record all bad pages.
11. Install the Rigid Disk Utilities floppy and press Function Key (F2).
  - Select 3, Tech Support. enter password (REXIFSN)
  - Select "Format Rigid Disk". Run 1 pass with 0 retries.

**NOTE:** "Formatting the Rigid disk drive creates a physical volume and logs bad pages into the table automatically. Compare all bad pages recorded in step 10 with step 12 and enter any pages that are not listed on the error map.

**NOTE:** Some of the Manufacturers bad pages may be out of range and cannot be entered due to the logical disk size limitations (areas not accessed by the software). However, this is not a problem as long as the correct Disk Drive Model number was entered during configuration.

12. Return to bad page utilities.
  - Select "enter page by number"
  - Enter pages recorded in step 10.
13. Return to main menu and select Confidence Test. Confidence Test passed.  
 YES ↓    NO → Call for assistance.
14. Place a copy of the bad page table next to the Rigid Disk Drive.
15. Ask the system administrator to partition the disk and install software, boot software and then go to Ch. 5, Final Actions.

<b>Table 4-1 Rigid Disk Models</b>	
<u>VENDOR MODEL</u>	<u>XEROX DRIVE SIZE/MODEL</u>
Seagate ST212	10MB Rigid Disk-Model 1
Tandom TM703	20MB Rigid Disk-Model 1
Tandom TM702	20MB Rigid Disk-Model 2
Seagate ST4026	20MB Rigid Disk-Model 3
Quantum Q540	40MB Rigid Disk-Model 1
Quantum Q530	20MB Rigid Disk-Model 2
Micropolis 1303	40MB Rigid Disk-Model 2
Micropolis 1325	80MB Rigid Disk-Model 1



**REPAIR DATA**

**4.11 FLOPPY DISK DRIVE**

**REMOVAL**

- 1. Switch off the system power.
- 2. Access the back of the processor.
- 3. Remove the Rear Cover. (4.1)
- 4. Unplug the floppy disk drive power cord.
- 5. Unplug the floppy disk drive cable from the IOP PWBA and the drive.
  - a. Loosen jacks screws that secure cable.
- 6. Pull the floppy disk drive assembly up until the mounting clips release.

**REPLACEMENT**

- 1. Install the tops of the four "M" shaped mounting clips in the slots located on the bottom of the floppy disk drive assembly (Figure 4-8).
- 2. Place the floppy disk drive assembly with the mounting clips on the processor and align the clips with the slots in the top of the processor. Press firmly until the assembly snaps into place.
- 3. Perform the remainder of the removal procedure in the reverse order, starting with Step 5a.

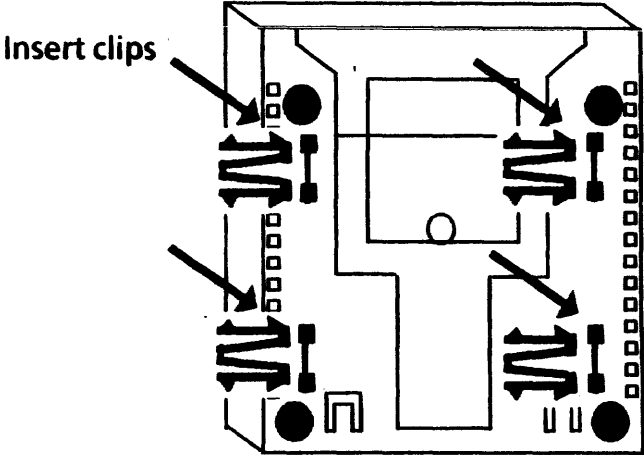

**Floppy Disk Drive  
Bottom View**

Figure 4-8 Floppy Disk Drive

**4.12 IOP PWBA**

**REMOVAL**

**CAUTION**

If the system identification number (contained in the ID PROM on the IOP PWBA) changes, it may cause the system to be ignored by the Ethernet Network or give an indication that the software is not configured. Any time that you are directed to replace the IOP PWBA, you will need to transfer the ID PROM and the EEPROM to the new PWBA. If the ID PROM is ever replaced, the System Administrator must be notified.

1. Switch off the system power.
2. Access the back of the processor.
3. Release the cable retaining clamp. (4.3)
4. Disconnect all of the cables attached to the IOP PWBA.
5. Loosen the two screws on the IOP PWBA and gently pull the board from the processor.

**CAUTION**

The ID PROM and the EEPROM can be damaged by static electricity. To prevent damage, always handle IC chips by the ends. **DO NOT** handle chips by their leads.

6. Locate the ID PROM and the EEPROM on the old IOP PWBA (Figure 4-9) and remove them for use with the new IOP PWBA.
  - a. Use the IC Chip removal procedure (4.16).

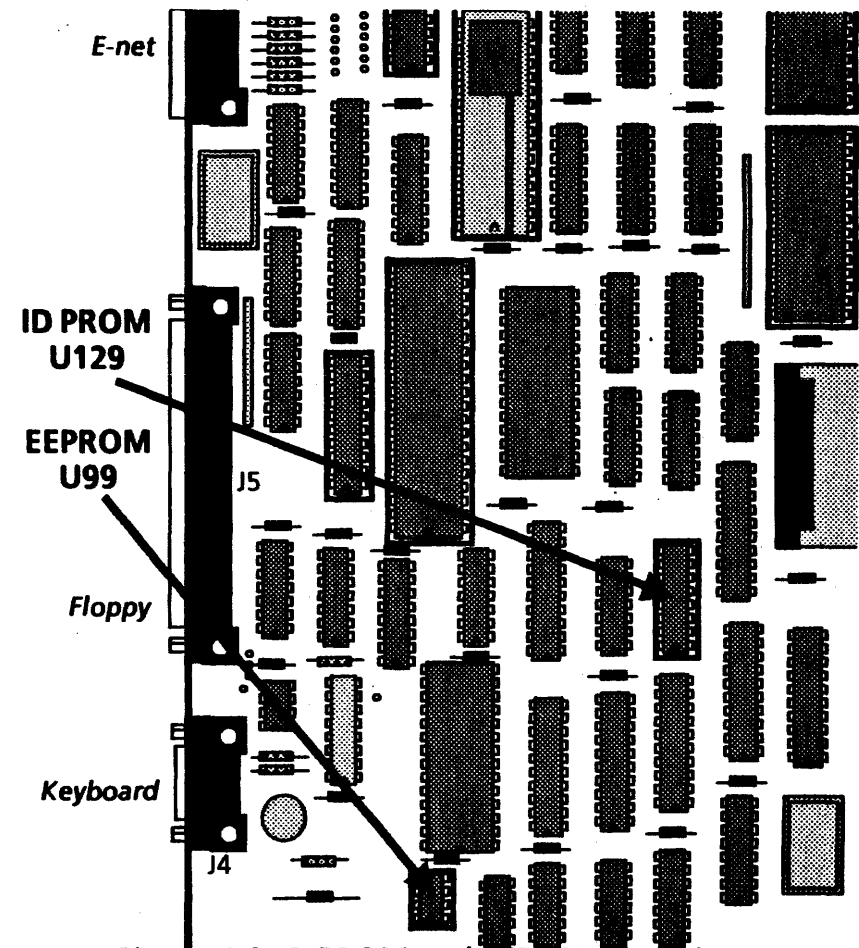

Figure 4-9 ID PROM and EEPROM Location

## **REPAIR DATA**

---

### **REPLACEMENT**

1. Replace the ID PROM and the EEPROM using the IC Chip replacement procedure. (4.16)
2. To complete the replacement of the IOP PWBA, perform the removal procedure in the reverse order, starting with Step 4.

### **4.13 BOOT PROMS**

### **REMOVAL**

1. Switch off the system power.
2. Access the back of the processor.
3. Release the cable retaining clamp. (4.3)
4. Disconnect all of the cables attached to the IOP PWBA.
5. Loosen the two screws on the IOP PWBA and gently pull the board from the processor.

**CAUTION**

The BOOT PROMs (EPROMs) can be damaged by static electricity. To prevent damage, always handle IC chips by the ends. DO NOT handle chips by their leads.

6. Locate the Boot PROMs on IOP PWBA (Figure 4-10) and remove them using the IC Chip removal procedure. (4.16)

**REPLACEMENT**

1. Replace the Boot PROMs using the IC Chip replacement procedure. (4.16)
2. To completed the replacement of the IOP PWBA, perform the removal procedure in the reverse order, starting with Step 4.

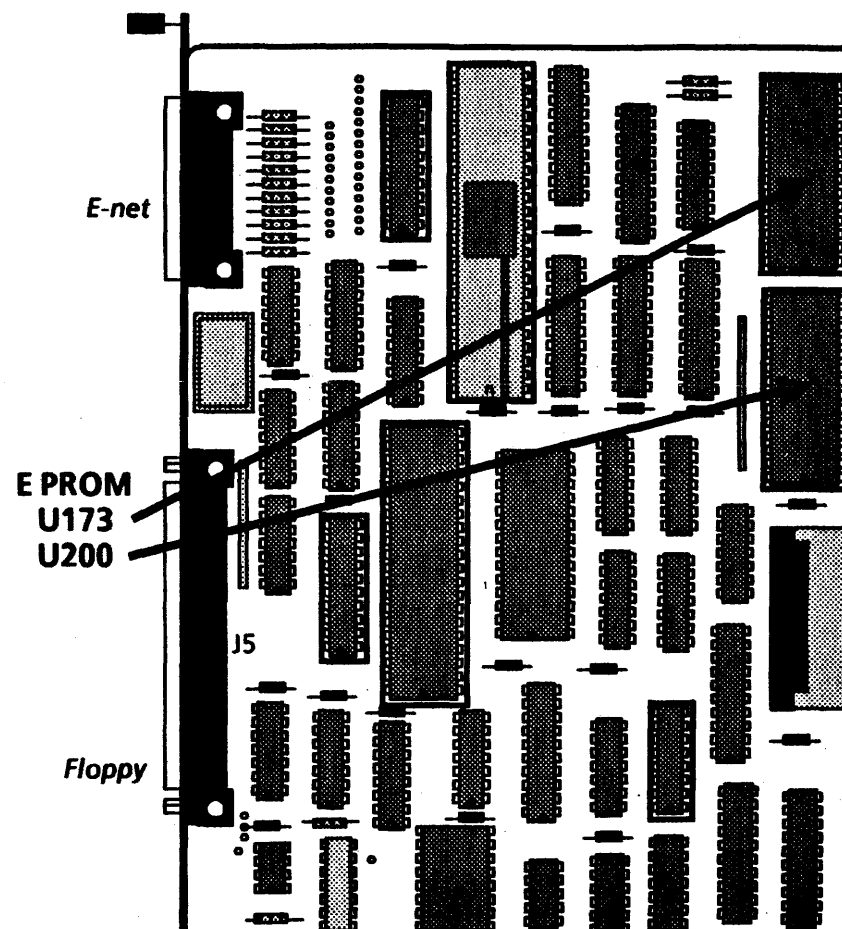

Figure 4-10 Boot PROM Locations

## REPAIR DATA

---

### 4.14 MEB PWBA MEMORY CHIPS

**NOTE:** Use this procedure to install memory upgrade IC chips on the MEB PWBA.

#### REMOVAL

1. Switch off the system power.
2. Access the back of the processor.
3. Release the cable retaining clamp. (4.3)
4. Loosen the two screws on the MEB PWBA and gently pull the board from the processor.

#### CAUTION

The memory chips can be damaged by static electricity. To prevent damage, always handle IC chips by the ends. **DO NOT** handle chips by their leads.

#### REPLACEMENT.

**NOTE:** Memory chips are always installed in banks of eighteen chips.

1. Determine where the memory chips will be installed. (Figure 4-11)
  - a. Each bank of memory chips is installed in an eighteen chip row directly below the last full

row. (For example, the second row of chips would be located in positions U29, U38, U47, U56, U61, U70, U77, U84, U90, U95, U104, U113, U122, U127, U136, U145, U150, and U159.)

2. Install the memory chips using the IC Chip replacement procedure (4.16).
3. To complete the replacement of the MEB PWBA, perform the removal procedure in the reverse order.

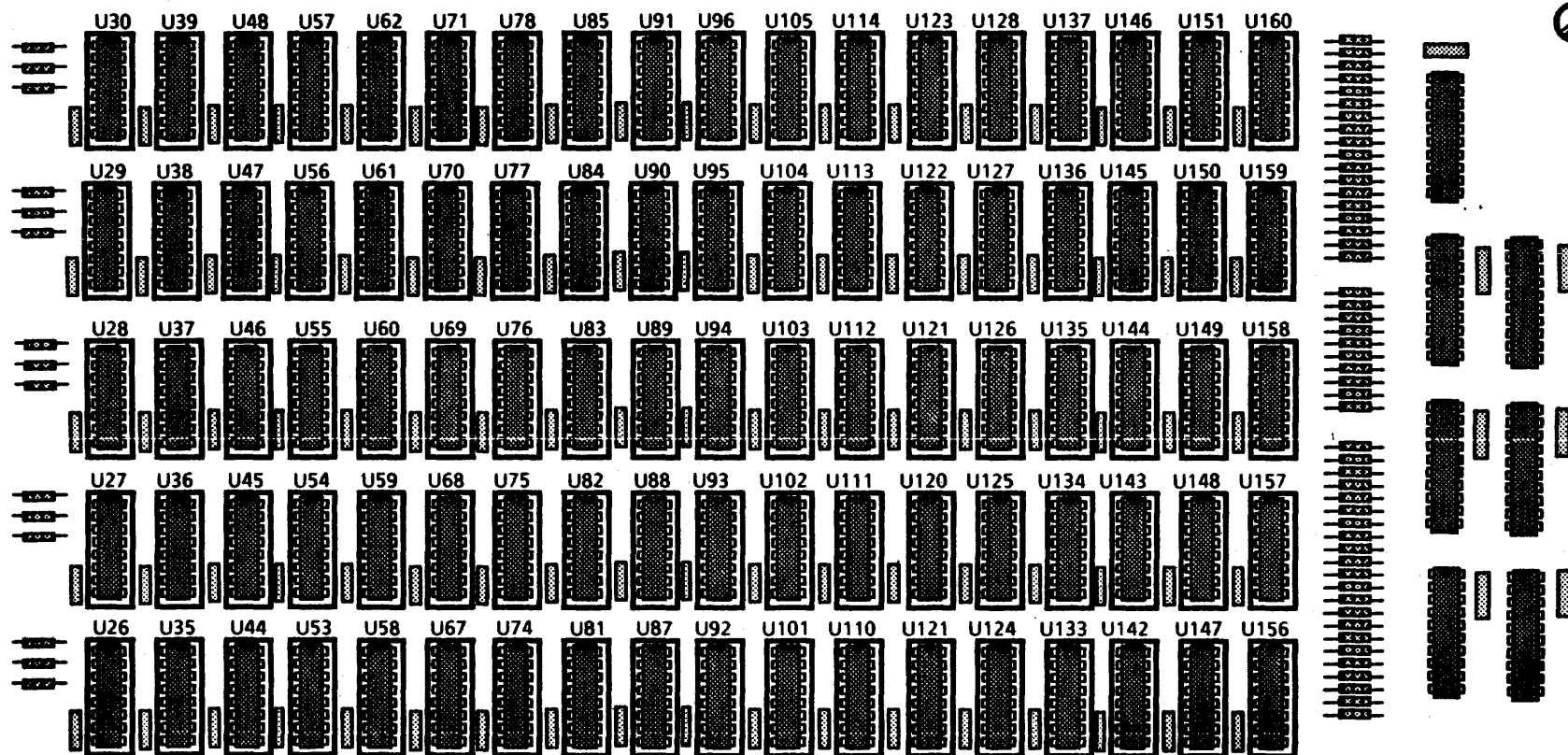

Figure 4.11 - MEB PWBA (shown fully loaded)

## REPAIR DATA

---

### 4.15 MPB PWBA

**NOTE:** Use this procedure to install the 4Kw Control Store upgrade IC chips on the MPB PWBA.

#### REMOVAL

1. Switch off the system power.
2. Access the back of the processor.
3. Release the cable retaining clamp. (4.3)
4. Loosen the two screws on the MPB PWBA and gently pull the board from the processor.

#### CAUTION

The memory chips can be damaged by static electricity. To prevent damage, always handle IC chips by the ends. **DO NOT** handle chips by their leads.

#### REPLACEMENT

1. Locate the sockets that will receive the twelve chips (Figure 4-12). These sockets are numbered U95, U96, U105, U106, U121, U122, U137, U138, U153, U154, U169, and U170.
2. Install the memory chips using the IC Chip replacement procedure (4.16).

3. To complete the replacement of the MPB PWBA, perform the removal procedure in the reverse order.

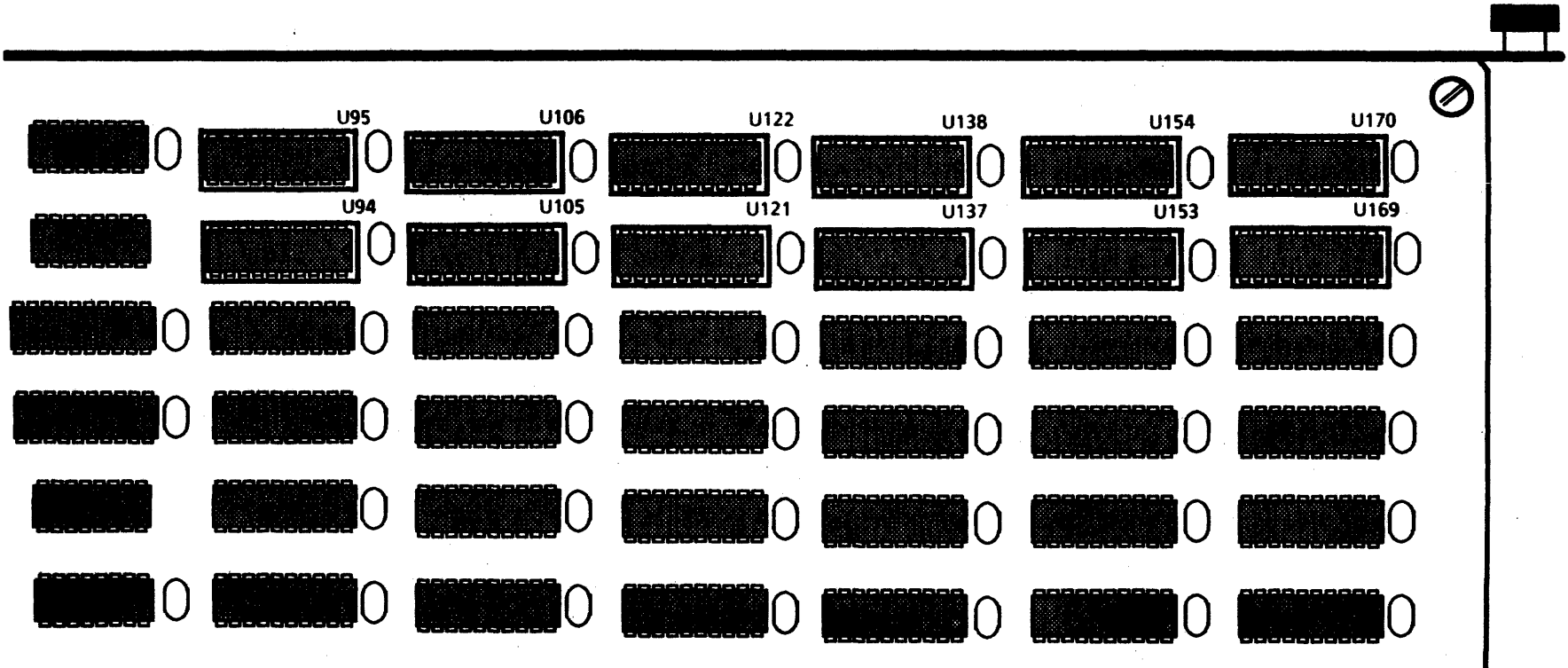

Figure 4-12 MPB PWBA



## REPAIR DATA

### 4.16 IC CHIPS

#### REMOVAL (Figure 4-13)

1. Switch off the system power.
2. Release the cable retaining clamp. (4.3)
3. Remove the PWBA that needs to have an IC Chip replaced.

#### CAUTION

Memory chips can be damaged by static electricity. To prevent damage, always handle IC chips by the ends. **DO NOT** handle chips by their leads.

4. Remove the IC Chip using the Chip Removal Tool (600T80042).
  - a. Squeeze the two legs of the tool together so that the IC chip is held firmly.
  - b. Gently rock the IC tool back and forth, alternately lifting each end of the chip, until the IC is free from the socket.

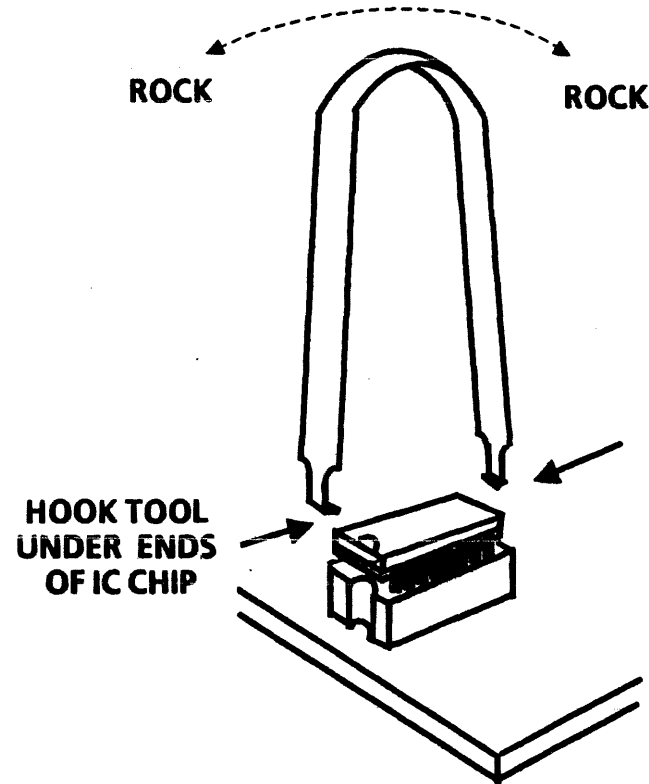

Figure 4-13 IC Chip Removal

**REPLACEMENT** (Figures 4-14, 4-15 and 4-16)**CAUTION**

Memory chips can be damaged by static electricity. To prevent damage, always handle IC chips by the ends. **DO NOT** handle chips by their leads.

1. Inspect the new IC Chip. If the pins are straight, go to Step 4. If the pins are bent outward, go to Step 2. If the pins are bent inward, go to Step 3. If some pins are bent outward and some are bent inward, perform Step 2 and Step 3.
2. If the pins are bent outwards, they must be straightened before the IC Chip can be installed. (Figure 4-14)
  - a. Select insertion tool for IC chips with fourteen to sixteen pins (600T80037), or insertion tool for IC chips with eighteen to twenty pins (600T80041) as required.
  - b. Gently push the IC chip into the correct insertion tool with your fingers or place the IC chip on a flat surface and use the tool to pick up the IC chip, rocking the tool back and forth gently. (When using the fourteen to sixteen pin insertion tool (600T80037) to pick up an IC chip, you must hold in the ejector button.)
  - c. Proceed to Step 5.

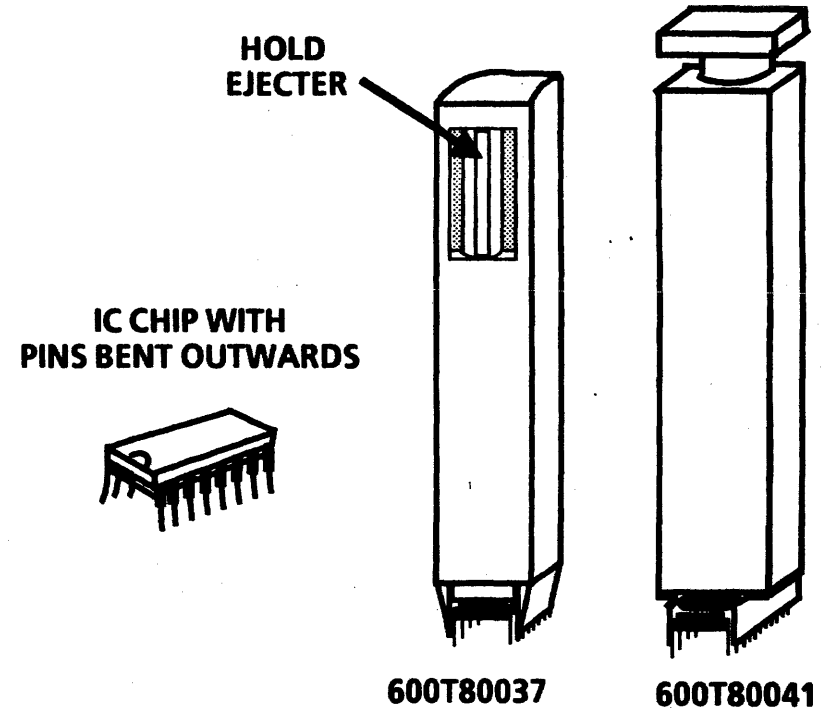
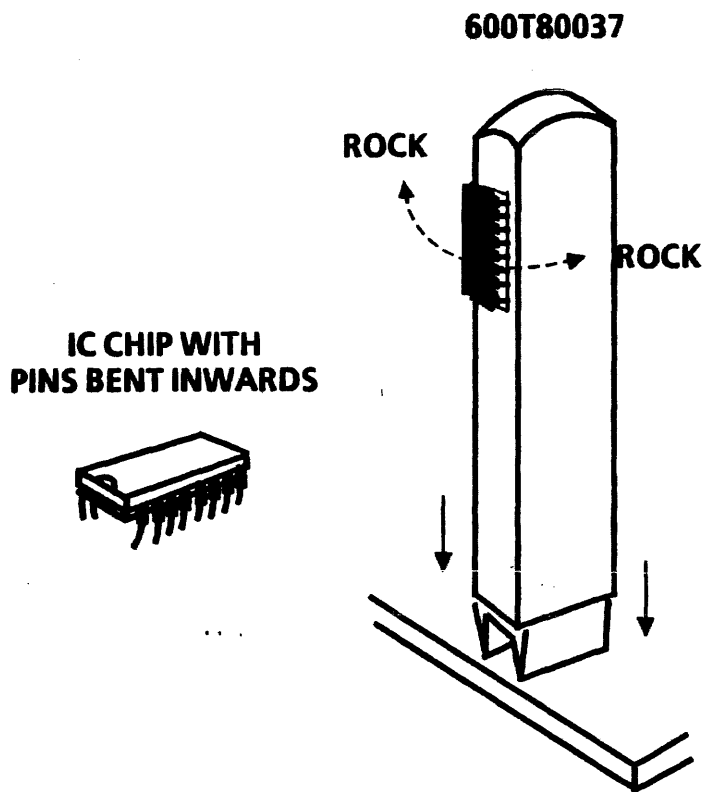

Figure 4-14 Straightening Bent IC Chip Pins

**REPAIR DATA**



3. If the pins are bent inward, they must be straightened before the IC Chip can be installed. (Figure 4-15)
  - a. Push the IC chip into the pin straightener portion of the IC Insertion Tool (600T80037).
  - b. Gently rock the IC back and forth to straighten out the pins.
  - c. Eject the IC chip from the insertion tool by pushing the spring loaded base of the tool against a flat surface.
  - d. Proceed to Step 4.
4. Place the IC Chip in the Insertion Tool.
  - a. Select insertion tool for IC chips with fourteen to sixteen pins (600T80037), or insertion tool for IC chips with eighteen to twenty pins (600T80041) as required.
  - b. Gently push the IC chip into the correct insertion tool with your fingers or place the IC chip on a flat surface and use the tool to pick up the IC chip, rocking the tool back and forth gently. (When using the fourteen to sixteen pin insertion tool [600T80037] to pick up an IC chip, you must hold in the ejector button.) (Figure 4-14)

Figure 4-15 Straightening Bent IC Chip Pins

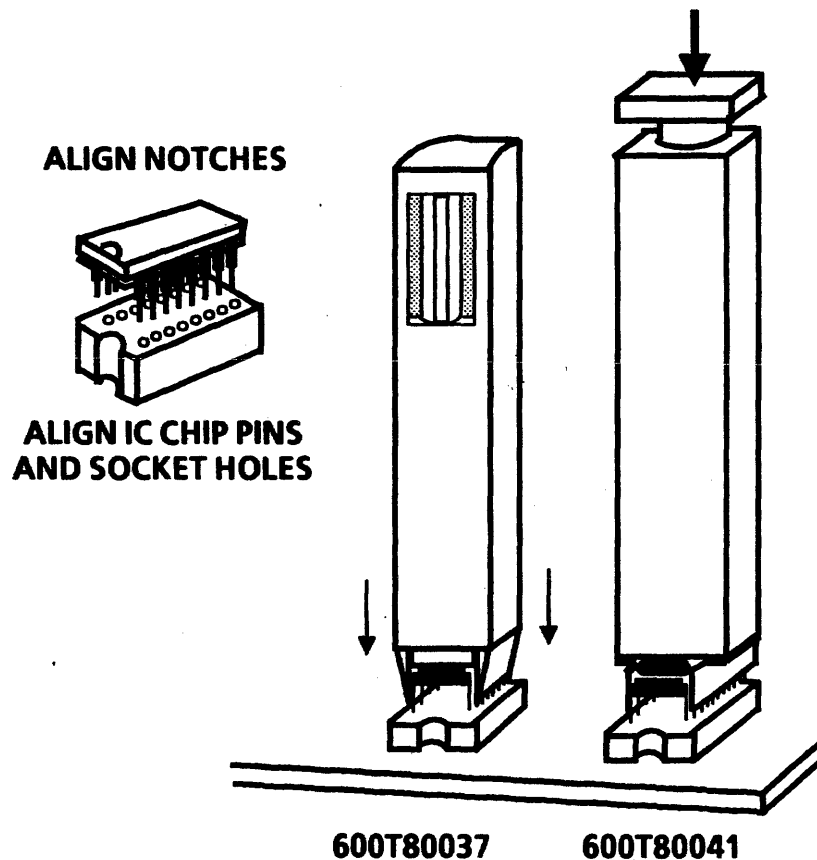

Figure 4-16 IC Chip Insertion

**CAUTION**

Memory chips can be damaged by static electricity. To prevent damage, always handle IC chips by the ends. **DO NOT** handle chips by their leads.

5. Insert the new IC Chip into the socket on the PWBA. (Figure 4-16)
  - a. Ensure that the notch on the end of the socket and the notch on the end of the IC chip are lined up.
  - b. Carefully align the pins of the IC chip with the holes in the socket on the PWBA. Ensure that each pin is started properly in its corresponding socket hole before continuing to the next step.
  - c. If using tool 600T80037, push the insertion tool down. If using tool 600T80041, depress the button on top of the tool.
  - d. Remove the IC chip insertion tool.

<b>4.17 15" DISPLAY COVER</b>
-------------------------------

**REMOVAL**

1. SWITCH OFF PROCESSOR POWER.
2. REMOVE DISPLAY COVER.
  - a. Remove two screws at the bottom left and right corners of the cover.

## REPAIR DATA

---

- b. Insert slot screwdriver into the seam where the cover mates with the bezel  $1\frac{1}{2}$  inches in from the top right hand corner, pushing the screwdriver toward the front of the CRT. When the screwdriver reaches a small cutout in the cover, lift the handle of the screwdriver to release the locking mechanism on the right side.

### REPLACEMENT

1. REPLACE THE DISPLAY COVER.
  - a. Put the cover in place and press it onto the display until the top left and right retainers snap into place.
  - b. Install the two screws at the bottom left and right corners of the cover.

### 4.18 15" DISPLAY SHIELD

#### REMOVAL

1. SWITCH OFF PROCESSOR POWER.
2. REMOVE DISPLAY COVER (4.17).
3. REMOVE DISPLAY SHIELD.
  - a. Remove ten screws holding shield to chassis.
  - b. Remove display shield.

#### REPLACEMENT

1. REPLACE THE DISPLAY SHIELD.
  - a. Perform removal procedure in reverse order.

### 4.19 15" DISPLAY IMAGE ADJUSTMENTS

#### CAUTION

Do not adjust any control pot other than those indicated in the following adjustment procedures.

1. SWITCH OFF PROCESSOR POWER.
2. REMOVE DISPLAY COVER (4.17).
3. REMOVE DISPLAY SHIELD (4.18).

**WARNING**

Be careful of high voltage on the CRT, yoke, anode, anode lead and PWBA's. Remove all jewelry before performing the display adjustments. When power is applied, use only one hand to make adjustments. Touching the display or processor with both hands can cause a dangerous electrical shock.

4. MARK FACE OF CRT FOR ALIGNMENT.
  - a. Using a felt tip pen, mark face of the display as shown in Figure 4-17.
5. SWITCH ON PROCESSOR POWER.
6. PERFORM ON-LINE DIAGNOSTICS FOR THE DISPLAY.
  - a. Select the bold @ symbol pattern.
7. IF THE DISPLAY IS NOT LOCKED IN HORIZONTALLY, ADJUST H HOLD (R110) UNTIL IT IS LOCKED IN SOLID.

**CAUTION**

Prior to making the adjustments or checking the alignment, system power must be ON for a warmup time of ten minutes.

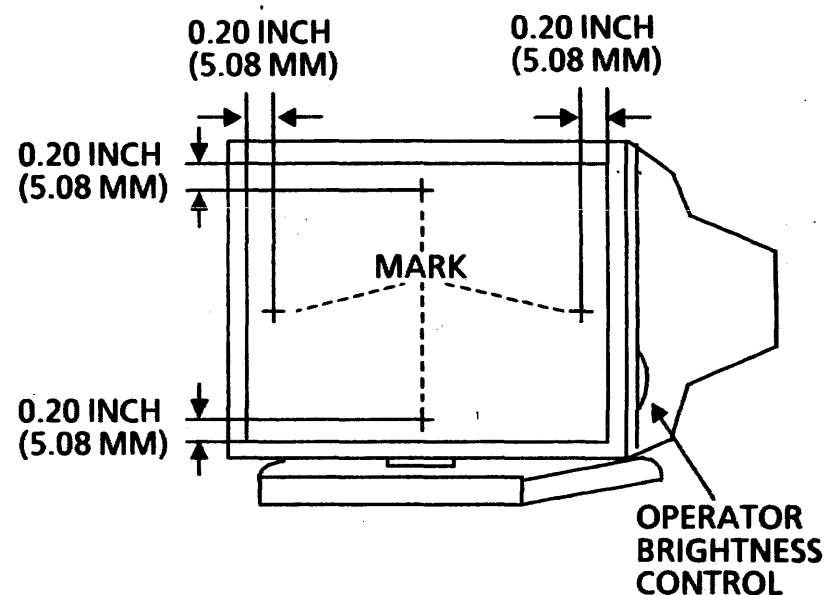

Figure 4-17 6085 15 Inch Display

## REPAIR DATA

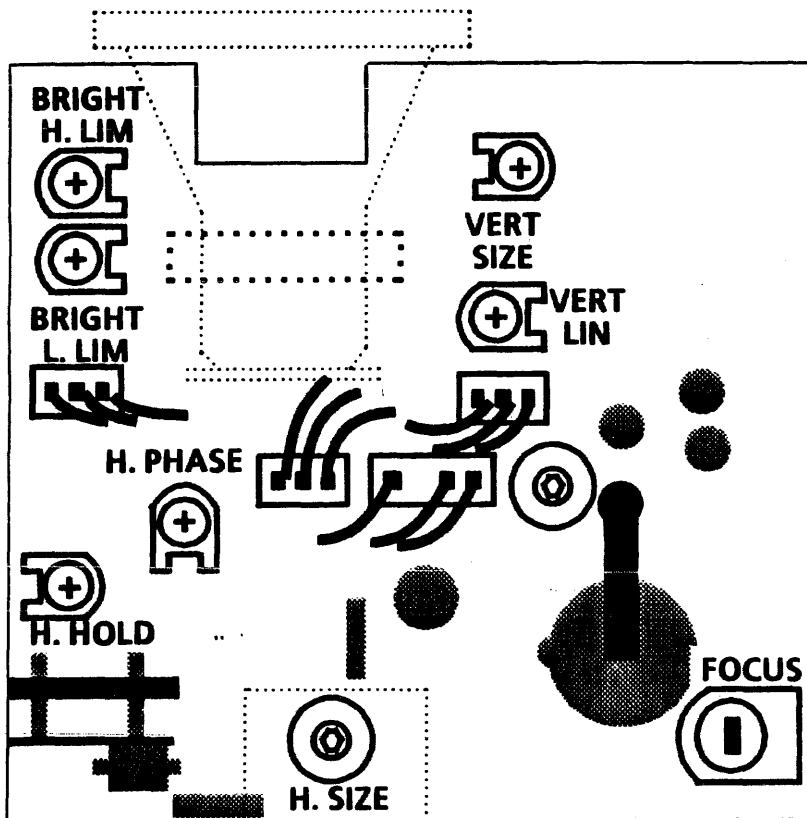

Figure 4-18 15" Display PWBA Adjustment Locations

8. CHECK/ADJUST BRIGHTNESS.
  - a. Move the operator brightness control to minimum setting.
  - b. Observe that the display is almost completely dark, with dim characters visible.
  - c. If the check is correct proceed to step e.
  - d. With operator brightness control set to minimum brightness, adjust **BRIGHT L. LIM** to make characters almost invisible.
  - e. Set the operator brightness control to maximum brightness.
  - f. Check to ensure that the display is not too bright, with no character badly out of focus. Retrace lines may be visible.
  - g. If all is correct, proceed to step 9.
  - h. With operator brightness control set to maximum brightness, adjust **BRIGHT H. LIM** to specifications in step f.
  
9. CHECK/ADJUST FOCUS.
  - a. Move the brightness control to desired setting.
  - b. Set the contrast control (R505) for optimum viewing.
  - c. Verify that all characters can be identified as @ symbols.
  - d. If the checks are correct, proceed to step 10.
  - e. Adjust **FOCUS** pot (R707) for optimum viewing.

**10. CHECK/ADJUST RASTER CENTERING.**

- a. Select the H pattern.
- b. Adjust the operator brightness control so that the raster is visible.
- c. Adjust the VERT LIN control for approximately the same size characters in the top and bottom rows.
- d. Select the crosshatch pattern.
- e. The vertical center line of the crosshatch pattern should fall within 0.05 inches of the vertical part of the felt pen mark on the top and bottom of the CRT and the horizontal center line of the crosshatch pattern should fall within 0.05 inches of the horizontal part of the felt pen mark on the left and right side of the CRT.
- f. If all is correct, proceed to step 12.
- g. Center the raster within the marks by adjusting the centering rings on the back of the yoke.

**11. ADJUST RASTER TILT.**

**NOTE:** If after centering the raster in step g above the specifications in step e above cannot be met, the raster must be tilted.

- a. Loosen the yoke clamp.
- b. Rotate the yoke until the vertical and horizontal center lines of the crosshatch come within 0.05 inches of the felt pen marks at the top, bottom, left and right sides of the CRT.

**12. CHECK/ADJUST HORIZONTAL SIZE.**

- a. Ensure that the left and right sides of the raster come within 0.05 inches of the vertical lines of the felt pen marks at the left and right sides of the screen.
- b. If correct, proceed to step 13.
- c. Adjust the H SIZE coil to obtain correct display width.

**13. CHECK/ADJUST VERTICAL SIZE.**

- a. Ensure that the top and bottom of the raster is within 0.05 inches of the horizontal lines of the felt pen marks at the top and bottom of the screen.
- b. If correct, proceed to step 14.
- c. Adjust VERT SIZE to obtain correct display height.

**NOTE:** This moves the whole raster, not the video within the raster. It may be necessary to alternate adjusting the VERT SIZE and VERT LIN to obtain optimum centering of the raster.



**CHAPTER 5 FINAL ACTIONS**  
**6085 Product Support Manual**

**5**

## **FINAL ACTIONS**

---

### **CALL COMPLETION PROCEDURE**

**Perform the Call Completion Procedure to verify that the Work Station operates correctly following a repair.**

#### **PROCEDURE**

- 1. If any parts were replaced during troubleshooting that were not the cause of the problem, restore them to the machine.**
- 2. Run the System Check in Chapter 1 to verify that the machine is operating correctly.**
- 3. Replace any covers removed during the service call.**
- 4. Clean equipment panels and restore order to the customer's work area.**
- 5. Review with the customer any operator training points that might help to avoid future calls.**
- 6. Complete all required administrative tasks.**

**CHAPTER 6 GENERAL INFORMATION**  
**6085 Product Support Manual**

**6**

## GENERAL INFORMATION

---

### **DOCUMENTATION INFORMATION**

**How to Use This Manual.** This information is located on the inside of the front page of this manual. Additional information about the service documentation is provided below.

### **REVISION MARKS**

The Product Support Manual revisions are provided by a change package or a new issue of the manual. A letter (at the bottom of the page) identifies the level of revision on the changed or added pages. The following list defines the methods used to identify the changes on each page.

Text	A change bar in the left margin
Tables	A change bar at the left side of the changed data
Changed Illustrations	A number (indicating the level of revision) next to the drawing number; a change bar at the left side of the drawing number

New Illustrations      A change bar at the left side of the drawing number

When the additional levels of revision occur, the identifiers for the earlier revisions are taken out, and only the new revisions are identified. Each revision includes a new title page containing a Revision Control List. The list provides the page numbers where the revisions have occurred as well as the letters for identifying the level of revision.





### **IDENTIFICATION OF SPECIFIC ITEMS**

If parts or data are used only with a specific device, the applicable device is identified with one of the notations defined below. If no notation is provided, the part or data is used multinationally for all of the applicable devices.

RX	-- Rank Xerox
USO	-- United States Operations
USO/XC	-- United States Operations/Xerox Canada
XC	-- Xerox Canada

**MANUAL SYMBOLS**



The symbols used in this Product Support Manual are defined below.

-  ENTIRE ILLUSTRATION AFFECTED BY TAG NUMBER IN SYMBOL
-  SPECIFIC PART OR SECTION AFFECTED BY TAG NUMBER IN SYMBOL
-  ENTIRE ILLUSTRATION NOT AFFECTED BY TAG NUMBER IN SYMBOL
-  SPECIFIC PART OR SECTION NOT AFFECTED BY TAG NUMBER IN SYMBOL

8010-144

**Figure 1-1 Tag Change Symbols**

The Tag change symbols appear on the exploded view illustrations in Chapter 3. The number within the symbol matches the tag number identified in the Change Tag Index in Chapter 6.

-  REMOVAL AND REPLACEMENT
-  ADJUSTMENT
-  REMOVAL, REPLACEMENT, AND ADJUSTMENT

8010-145

**Figure 1-2 Repair Procedure Symbols**

The repair procedure symbols appear on exploded view illustrations in Chapter 3, located near the applicable item number on the drawing. The number within the symbol (not shown in the figure) matches the number of the repair procedure provided in Chapter 4.

**COMMENT SHEETS**

Service Representatives can assist with creating accurate service documents by identifying errors or improvements. That information can be sent to Service Education personnel on a Comment Sheet, provided on the last page of each manual. Comment Sheets provide instructions for completion.

## GENERAL INFORMATION

---

### SPECIFICATIONS

The following specifications are for the devices included in the 6085 PCS Series Product Support Manual.

### PHYSICAL SPECIFICATIONS

#### Processor

Width	9.5 ins (24 cm)
Height	21 ins (53.3 cm)
Length	12.5 ins (31.7 cm)
Weight	60 Lbs (27.3 kg)

#### Keyboard

Width	7.5 ins (19 cm)
Height	1.25 ins (3.18 cm)
Length	19 ins (48.3 cm)
Weight	4 Lbs (1.8 kg)

#### Mouse

Width	2.25 ins (5.7 cm)
Height	1.25 ins (3.18 cm)
Length	3.75 ins (9.5 cm)
Weight	1 Lb (.45 kg)

#### Display, 15 Inch

Width	15 ins (38.1 cm)
Height	14 ins (35.6 cm)
Length	15 ins (38.1 cm)
Weight	30 Lbs (13.6 kg)

#### Display, 19 Inch

Width	TBS
Height	TBS
Length	TBS
Weight	TBS

#### Floppy Disk Drive

Width	9.5 ins (24 cm)
Height	2 ins (5 cm)
Length	12.5 ins (31.7 cm)
Weight	6 Lbs (2.7 kg)

**SPACE REQUIREMENTS**

For proper operation and ventilation there should be a two inch clearance on both sides and the rear of the processor, and the top of the display should not be covered or blocked.

Space requirements for Service should allow the system unit to be easily and safely withdrawn, with the cables attached, into an area large enough to allow easy access to the rear of the unit.

**ELECTRICAL SPECIFICATIONS**

Circuit conductors and ground conductors must be installed in accordance with local electrical requirements. A standard 15A, 2-pole, 3-wire grounded duplex receptacle is required for proper machine operation.

AC power for the 6085 Processor is obtained from a single grounded wall outlet. The 6085 Display, Keyboard/Mouse, and the Floppy Drive receive their power from the Processor. Voltages required at the wall outlet are:

USO/XC

103 to 127 VAC (RMS) line to neutral, 0 to 3 VAC neutral to ground, Single Phase, at 60 Hz

RX

194 to 264 VAC (RMS) line to neutral, 0 to 3 VAC neutral to ground, Single Phase, at 50 Hz

Maximum power consumption is measured at the nominal line voltage of 115 VAC (USO/XC), 230 VAC (RX). The following list contains power consumption specifications for various model configurations.

**Processor With  
15 Inch Display**

	<b>Current</b>	<b>Power</b>
<u>USO/XC</u>	4.13 Amperes	473 Watts
<u>RX</u>	1.88 Amperes	473 Watts

**Processor With  
19 Inch Display**

<u>USO/XC</u>	TBS	TBS
<u>RX</u>	TBS	TBS

## GENERAL INFORMATION

---

### ENVIRONMENTAL SPECIFICATIONS

#### Temperature Range

50°F to 90°F (10°C to 32°C)

#### Humidity Range

15% to 85%; maximum wet bulb temperature 78°F (26°C)

#### Operating Altitude

Up to 6,000 ft (1830 m) above sea level

#### Heat Dissipation

Processor (Max Config)	1462 btu/hr
Processor (Min Config)	853 btu/hr
Display, 15 inch	205 btu/hr
Display, 19 inch	341 btu/hr

#### Audible Noise

Processor 47 db

### PRODUCT CODES AND CONFIGURATIONS

A list of the product codes for 6085 Series devices is located in Tables 6-1 and 6-2. These devices are used to configure the various models of 6085 Series. Processor model configuration matrixes for USO/XC and RX are in Table 6-3. Each model configuration matrix contains the columns described below.

Hardware/Software Column. The first column in each matrix contains a list of required and optional devices used to configure the various models.

MODELS Columns. The columns are divided into the specific models of the product series. Each model column contains the symbol "X", aligned with the corresponding items in the Hardware column. The "X" symbols in each column identify devices used to configure that specific model. Each model has only one of each device unless a specified number is indicated in place of the "X" symbol.



**GENERAL INFORMATION**

<b>Table 6-1 6085 Series Product Codes</b>		
<b>Hardware</b>	<b>USO/XC</b>	<b>RX</b>
6085 Processor (with 10 MB Drive)	53DB	82D
6085 Processor (with 20 MB Drive)	53DC	83D
6085 Processor (with 40 MB Drive)	53DD	84D
6085 Processor (with 80 MB Drive)	53DE	85D
512 KB Memory Expansion PWBA	69D	69D
512 KB Memory Kit	74D	74D
Control Store Memory Kit	75D	75D
Network Connection	62D	62D
15 Inch Display	63D	91D
19 Inch Display	64D	92D
US Keyboard	65D	-
Japanese Keyboard	94D	-
European Keyboard	-	93D
Optical Mouse	80D	80D
360 KB Floppy Disk Drive	78D	78D
1.2 MB Floppy Disk Drive	TBD	TBD
PC Emulation Option	77D	77D

<b>Table 6-2 6085 Series Rigid Disk Drive Upgrade Kit Product Codes</b>			
<b>Disk Drive Capacity</b>		<b>USO/XC Code</b>	<b>RX Code</b>
<b>Current</b>	<b>Upgrade</b>		
10MB	20MB	TBD	TBD
10MB	40MB	TBD	TBD
10MB	80MB	TBD	TBD
20MB	40MB	TBD	TBD
20MB	80MB	TBD	TBD
40MB	80MB	TBD	TBD

**GENERAL INFORMATION**

<b>Table 6-3 6085 PCS Model Configuration Matrix</b>				
<b>Hardware</b>	<b>MODELS</b>			
	<b>6085 System Processor</b>			
	<b>Model 53DB (USO/XC) 82D (RX)</b>	<b>Model 53DC (USO/XC) 83D (RX)</b>	<b>Model 53DD(USO/XC) 84D (RX)</b>	<b>Model 53DE (USO/XC) 85D (RX)</b>
<b>Required Devices *</b> 6085 Processor with 1152 KB Memory and 10MB Disk Drive 20MB Disk Drive 40MB Disk Drive 80MB Disk Drive	X	X	X	X
<b>Optional Devices</b> 360 KB Floppy Disk Drive 1.2 MB Floppy Disk Drive 512 KB Memory Expansion PWBA 512 KB Memory Kits Control Store Memory Kit PC Emulation Option	X X X (1-4) X X	X X X (1-4) X X	X X X (1-4) X X	X X X (1-4) X X

\* All models require a Keyboard/Mouse and a Display (15 or 19 inch).

**TOOLS AND CONSUMABLES**

The following tools and consumables are required by all Service Representatives to service the 6085 Series products.

**TOOLS:**

600T191	Xerox Tool Case
600T293	Non-Ferrous Screwdriver
600T785	Flashlight
600T863	Inspection Mirror
600T932	All Handle (Xcelite)
600T934	1/4" Nut Driver
600T959	5", 5/16" Blade
600T960	6", 3/16" Blade
600T956	Pocket Screwdriver
600T1008	Quick Wedge Screw Starter
600T1605	CRT Alignment Tools (Non-metal)
600T1656	Universal Loopback Tool
600T1616	Digital Multimeter
600T1617	Test Lead Kit
600T1706	Transceiver Terminator Tool
600T80037	IC Chip Insertion Tool, 16 Pin
600T80041	IC Chip Insertion Tool, 20 Pin
600T80042	IC Chip Remover
600T91616	Interlock Cheater
95SXXXXX	Diagnostic Floppy Disks

**CONSUMABLES:**

601S74	Anti-Static Cleaner
73P80439	5 1/4" Drive Head Cleaning Kit

## **INSTALLATION PROCEDURES**

---

### **6.1 HARDWARE INSTALLATION OVERVIEW**

The Xerox 6085 Professional Computer System is comprised of four basic system components: a processor unit, a display, a keyboard, and an optical pointer. Each component is individually packaged. In addition, there are three optional system components: a personal computer option circuit board, a memory expansion circuit board, and a floppy disk drive assembly.

If your customer did not receive the four basic components, any optional components, the software or the accompanying documentation, have your customer call their Marketing Representative.

The following is a list of what is contained in each box. Items 1 through 4 are the basic components, and items 5 through 7 are optional components.

1. Processor Unit box. The Power Cord, a Screwdriver and the Processor Unit Unpacking Instructions (all located on the top styrofoam).
2. Display box. Display Power Cord, Display Cable and Keyboard Cable, connected to the Display.
3. Keyboard box. Coiled Keyboard Cable.

4. Pointer box. Pointer Cable attached to the Optical Pointer. The Optical Pointer is commonly referred to as the "Mouse." In addition, two Optical Mouse Pads and one Mechanical Mouse Pad are included in this box.
5. Floppy Disk Drive box. A set of four (4) clips and the Floppy Disk Drive Cable.
6. MEB Circuit Board box.
7. PCO Circuit Board box.

### **6.2 ELECTRICAL REQUIREMENTS**

Voltage 115V United States/Canada  
230V Rank Xerox

### **6.3 SAFETY REQUIREMENTS**

Your Xerox 6085 Professional Computer System has been designed and tested to meet strict safety requirements. These include safety agency (UL and CSA) examination, approval and compliance to established environmental and safety standards. Attention to the following notes will ensure the continued safe operation and performance of your computer.

- Always connect the computer to a properly grounded power source receptacle.

### **WARNING**

**Improper connection of the computer grounding conductor can result in risk of electrical shock.**

- Never use a ground adapter plug to connect the computer to a power source receptacle that lacks a ground connection terminal.
- Never attempt any maintenance functions that are not specifically called out in the Reference Manual.
- Never remove any covers or guards that are fastened with screws, except as explicitly instructed to do so in the instruction manual. In that case, always follow the instructions exactly as they are outlined.
- Never override or "cheat" electrical or mechanical interlock devices.
- Always exercise care in moving or relocating the computer. Refer to the instruction manual for correct procedures in lifting and moving the unit.

- Never operate the computer if unusual noises or odors are noticed. Disconnect the power cord from the power source receptacle and obtain Service to correct the problem.

### **6.4 UNPACKING THE BASIC SYSTEM COMPONENTS**

The following instructions tell you how to unpack and install your basic components and the floppy disk drive. Read the instructions and follow the illustrations.

#### **6.4.1 UNPACKING THE PROCESSOR UNIT**

1. Unpack the box marked "6085 Processor Unit" by tearing the perforations and folding down the styrofoam packing insert at the front of the Processor Unit. (Refer to Figures 1 and 2 of the Processor Unit.)
2. Face the front (look for the Xerox label) of the Processor Unit and grip the handle located at the bottom (under the front cover).
3. Carefully slide the Processor Unit half way off the pallette.
4. Tilt until the bottom of the Processor Unit touches the floor. (Refer to Figure 2.)

## INSTALLATION PROCEDURES

---

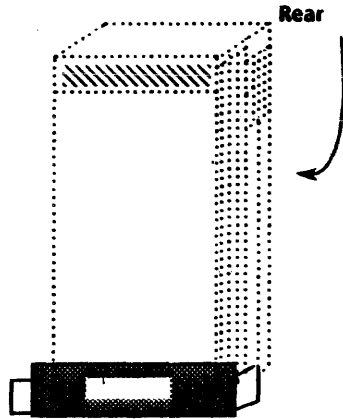

Figure 1. Side of Processor Unit

5. Tilt a bit more and while holding the Processor Unit at that angle, discard the packing from the bottom of the Processor Unit.

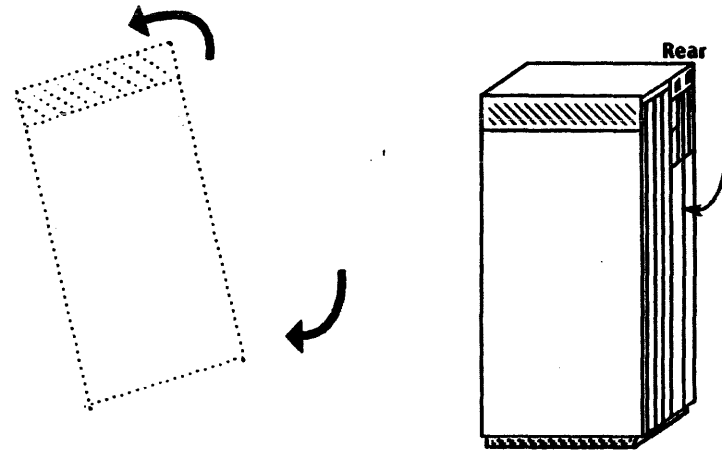

Figure 2. Unpacking the Processor Unit

### 6.4.2 UNPACKING THE DISPLAY

1. Unpack the box marked "Display."

**NOTE:** One way of unpacking the Display is by opening the box, then placing it so the Display is resting on foam packing. Grasp the bottom foam piece to slide out the Display.

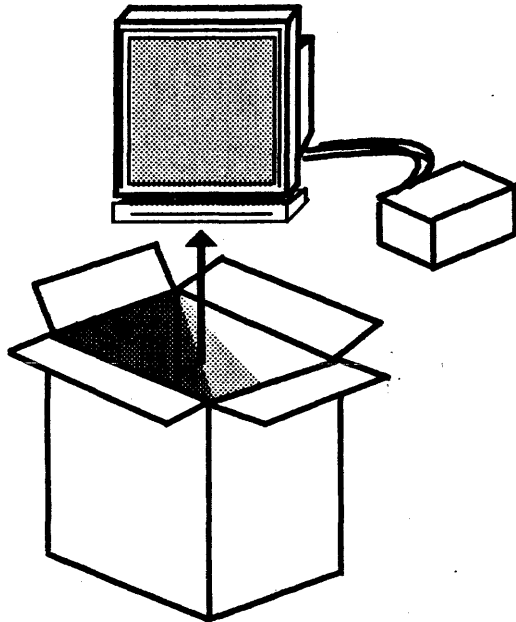

Figure 3. Unpacking the Display

**6.4.3 UNPACKING THE KEYBOARD**

1. Unpack the box marked "Keyboard."

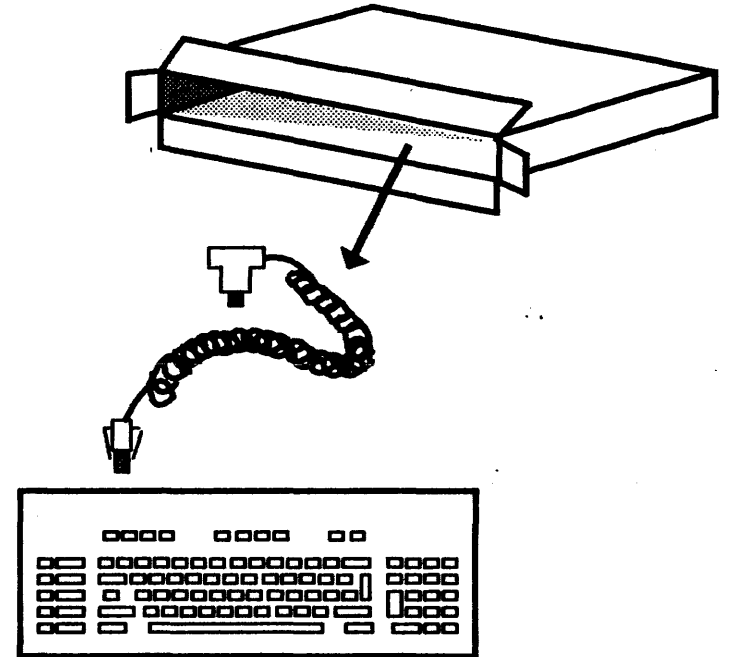

Figure 4. Unpacking the Keyboard

**INSTALLATION PROCEDURES**

---

**6.4.4 UNPACKING THE OPTICAL POINTER**

- 1. Unpack the box marked "Optical Pointer."

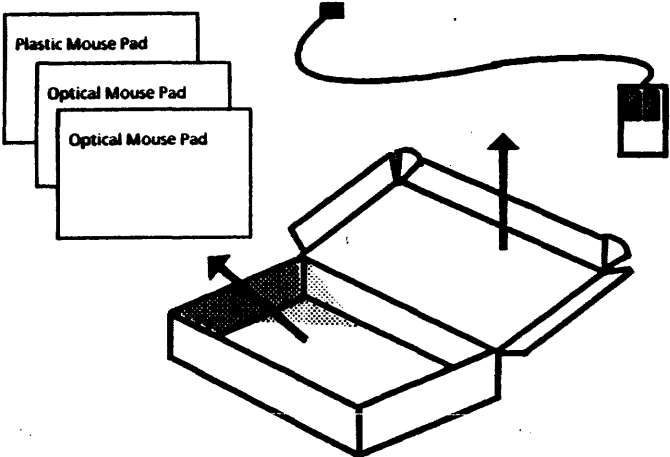

**Figure 5. Unpacking the Optical Pointer**



**6.5 UNPACKING THE OPTIONAL COMPONENTS**

**6.5.1 UNPACKING THE FLOPPY DISK DRIVE**

1. Unpack the box marked "Floppy Disk Drive."

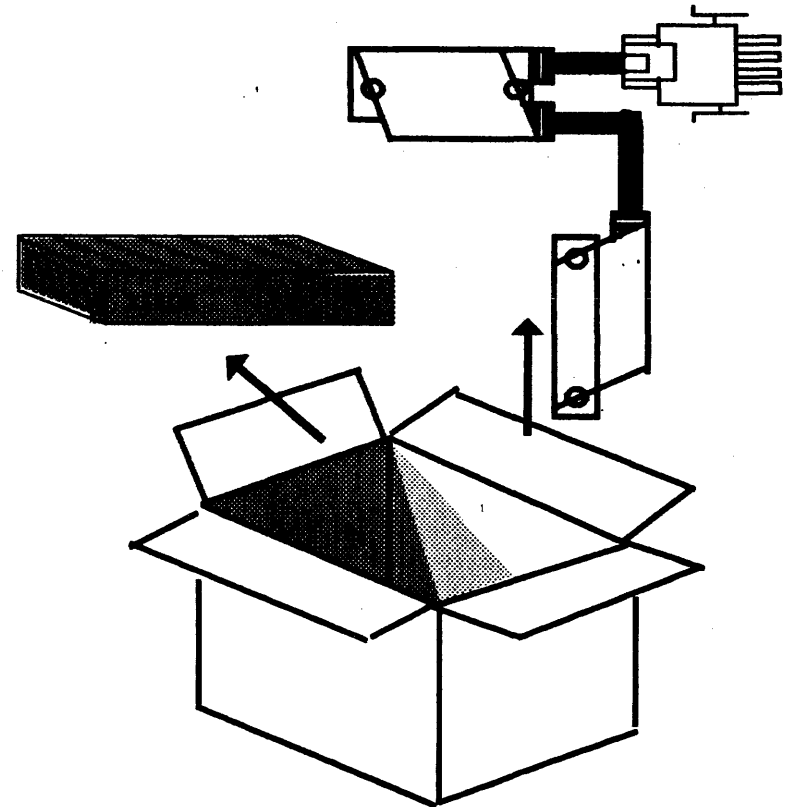

**NOTE:** A set of four (4) clips are also included in this box.

## INSTALLATION PROCEDURES

---

### 6.6 POSITIONING THE SYSTEM COMPONENTS

1. Place the Display, Keyboard, Optical Pointer, a Mouse Pad, and if applicable, the Floppy Disk Drive, on a tabletop.
2. Place the Processor Unit adjacent to the table, within 8 feet of a wall outlet.

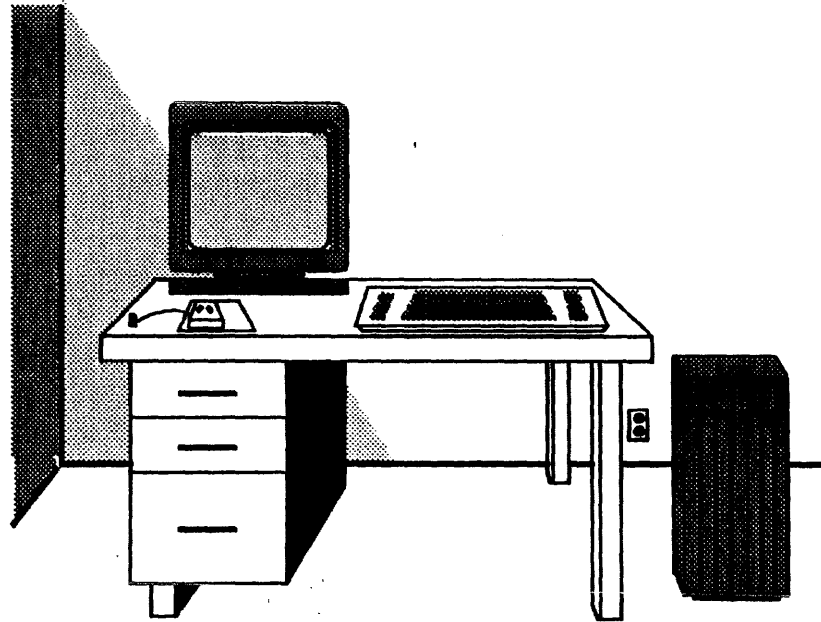

Figure 7. Positioning the System Components

**6.7 HARDWARE INSTALLATION**

**6.7.1 CONNECTING THE POINTER TO THE KEYBOARD**

1. Connect the cable attached to the Optical Pointer flush to the rear center of the Keyboard.

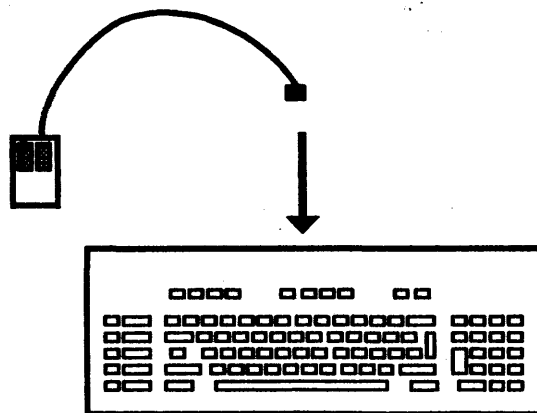

Figure 8. Connecting the Optical Pointer Cable to the Keyboard

2. Turn the Keyboard over.

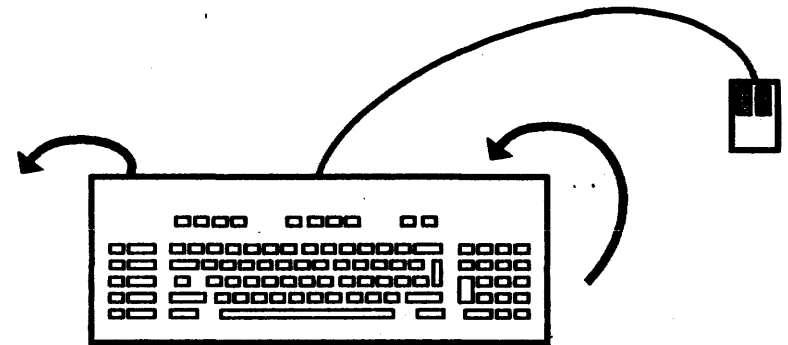

Figure 9. Top View of Keyboard

3. Thread the Mouse Cable through one side of the groove, and then turn the keyboard right side up.

**CAUTION**

Using sharp instruments to force the cable into the groove can cause damage to the cable. The clips on the Keyboard do not flex.

**NOTE:** The illustration shows the Mouse threaded to the right side of the keyboard when turned right side up.

## INSTALLATION PROCEDURES

4. Adjust the tilt of the Keyboard by pressing down and then turning the feet clockwise.

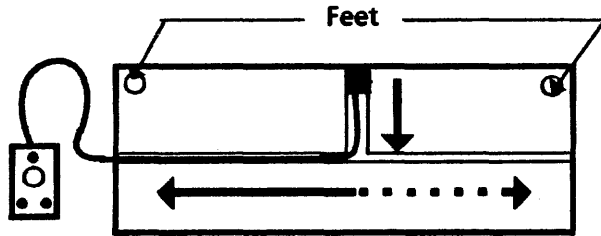

Figure 10. Bottom View of Keyboard

### 6.7.2 CONNECTING THE KEYBOARD TO THE DISPLAY

1. Attach the Keyboard Cable to the Display at the right side of the pedestal.

**NOTE:** To ensure the cable is properly connected, the notch of the connector should be on top. (Refer to Figure 11.)

2. Connect the other end of the Keyboard Cable to the Keyboard, at the left side.

**NOTE:** To ensure the cable is properly connected, the grooves on the connector should be on the bottom when you slide it into the Keyboard.

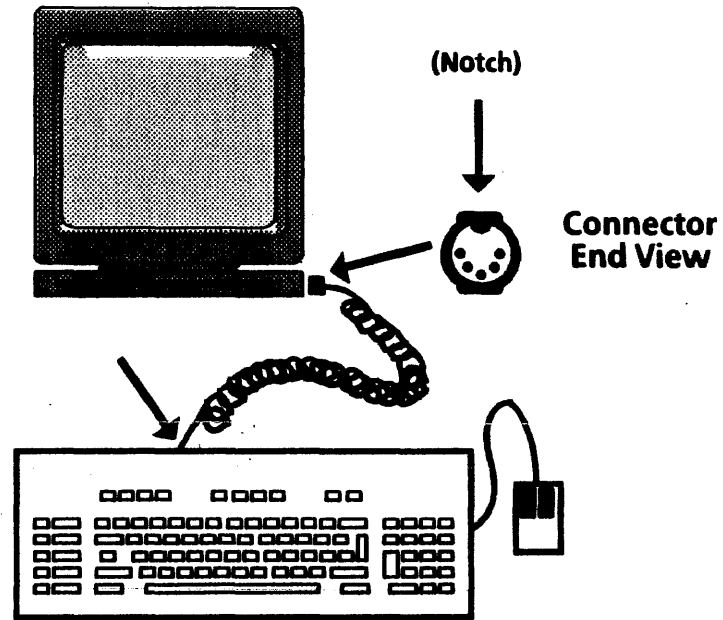
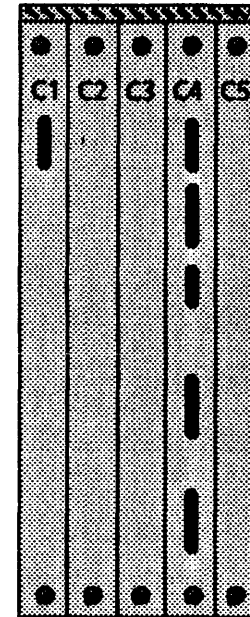

Figure 11. Keyboard and Display

**6.7.3 INSTALLING OPTIONAL CIRCUIT BOARDS**

1. If applicable, install your optional circuit boards by following the procedures in each Kit Instruction, then sliding the circuit board into the appropriate slot and tighten the thumbscrews finger-tight.

**NOTE:** The MEB Circuit Board goes into Slot C2 and the PCO Circuit Board goes into Slot C5.



**Circuit Boards**

- C1 DCM
- C2 MEB
- C3 MPB
- C4 IOP
- C5 PCO

Figure 12. Circuit Board Slots on the Processor Unit

## INSTALLATION PROCEDURES

---

### 6.7.4 INSTALLING AN OPTIONAL FLOPPY DISK DRIVE

Install the optional Floppy Disk Drive Assembly, if applicable.

If you plan to set the Floppy Disk Drive on top of the Processor Unit, perform steps 1 and 2. Otherwise, skip to step 3.

1. Carefully turn the Floppy Disk Drive over and insert the tops of the "M" shaped clips into the bottom of the Floppy Disk Drive as shown in Figure 13.

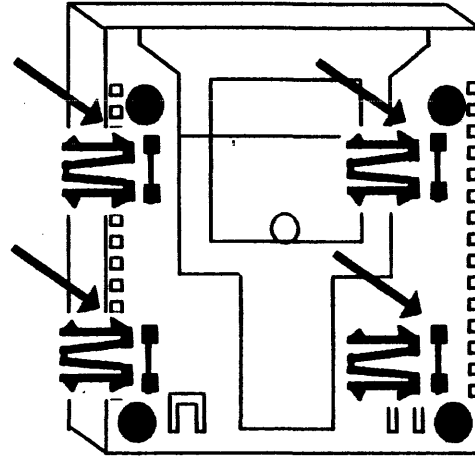

Figure 13. Bottom View of the Floppy Disk Drive

## INSTALLATION PROCEDURES

2. Carefully place the Floppy Disk Drive on top of the Processor Unit by aligning the four clips in the Floppy Disk Drive into four corresponding slots of the Processor Unit. (Refer to Figure 14.)

**NOTE:** To ensure that the Floppy Disk Drive is secure, the clips should become seated in place.

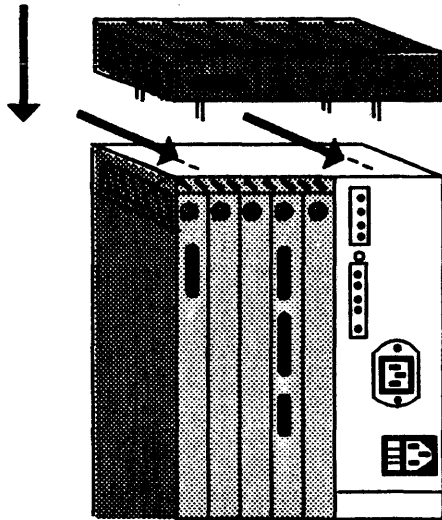

Figure 14. Placing the Floppy Disk Drive on the Processor Unit

3. Connect the Floppy Drive Cable to the following:
  - Floppy Drive
  - Processor Unit

**NOTE:** You will have to open the Rear Cover to attach the cable to the Processor Unit. Refer to step 2 of *Connecting the Cables to the Processor Unit*.

- C4 circuit board

Tighten the thumbscrews finger-tight. (Refer to Figure 15.)

## INSTALLATION PROCEDURES

---

ⓘ NOTE: This is an example of a thumbscrew.

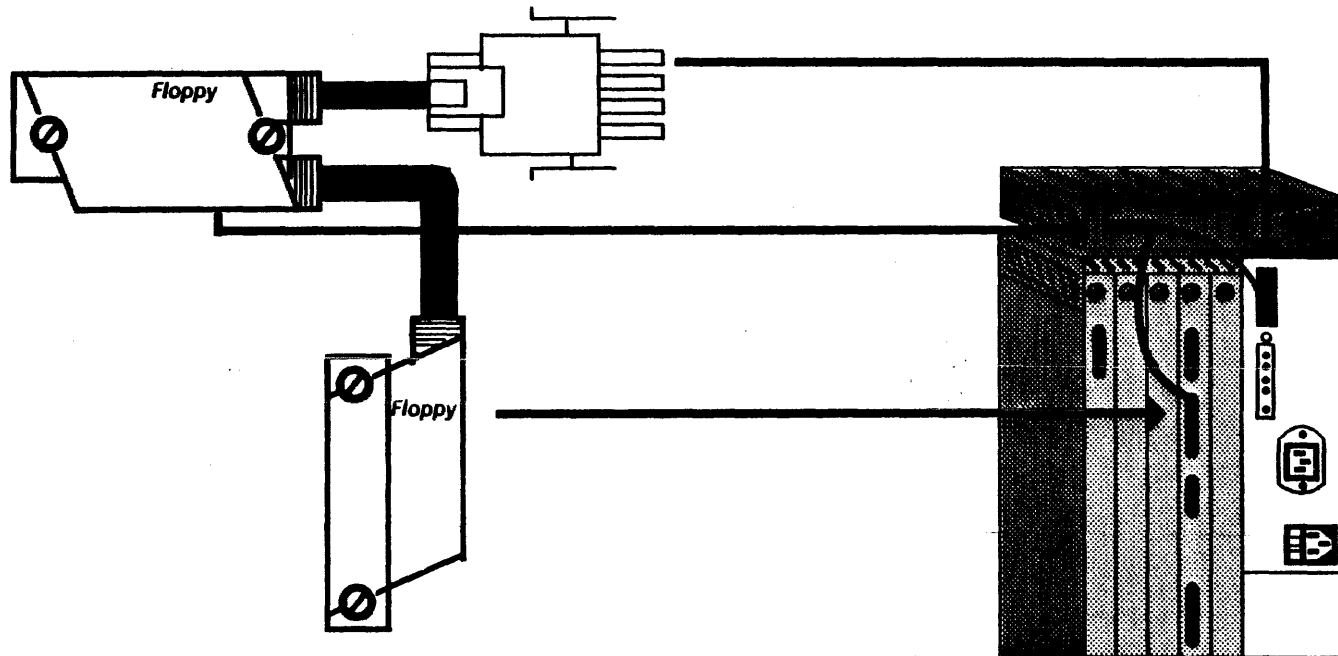

Figure 15. Connecting the Floppy Drive Cable to the Floppy Drive, the Processor Unit, and the C4 Circuit Board



4. Flip the front cover of the Floppy Drive down, then slide it back. (Refer to Figure 16.) Move the lever to the horizontal position. Remove the cardboard shipping disk from inside the floppy disk drive. Retain the shipping disk. Your customer will need it for moving or relocating the Floppy Disk Drive Assembly.

## INSTALLATION PROCEDURES

---



Floppy Disk Drive  
Front View

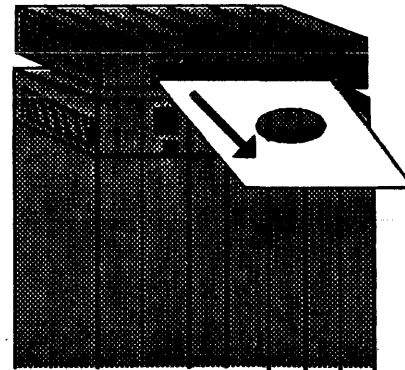
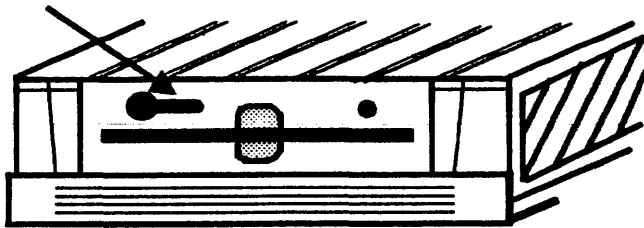

Figure 16. Removing the Floppy Shipping Disk

**6.7.5 CONNECTING THE CABLES TO THE PROCESSOR UNIT**

1. Uncoil the three cables (Display Power Cord, Display Cable and Keyboard Cable) from the rear of the Display.

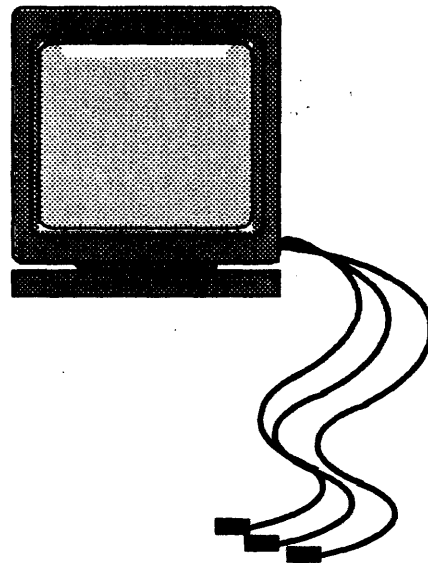

Figure 17. Uncoiling the Three Cables Attached to the Display

2. Open the Processor Unit Rear Cover by squeezing the latches and swinging it down.

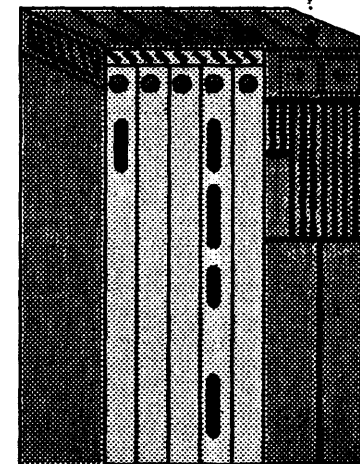
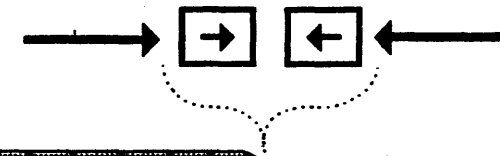

Figure 18. Opening the Processor Unit Rear Cover

3. Connect the cables to the Processor Unit C1 and C4 circuit boards and tighten the thumbscrews fingertight. (Refer to Figure 19.)

## **INSTALLATION PROCEDURES**

---

**NOTE:** The cables and the C1 and C4 circuit boards are appropriately labeled. Match the cable with the circuit board connectors.

### **Display, RS-232-C Port and Ethernet Connectors**

- a. Use the supplied screwdriver to tighten the Display cable and RS-232-C Port cables.
- b. Slide the metal piece down on the Ethernet connector, connect the Ethernet drop cable, and slide the metal piece of the connector up. This locks the drop cable in place.

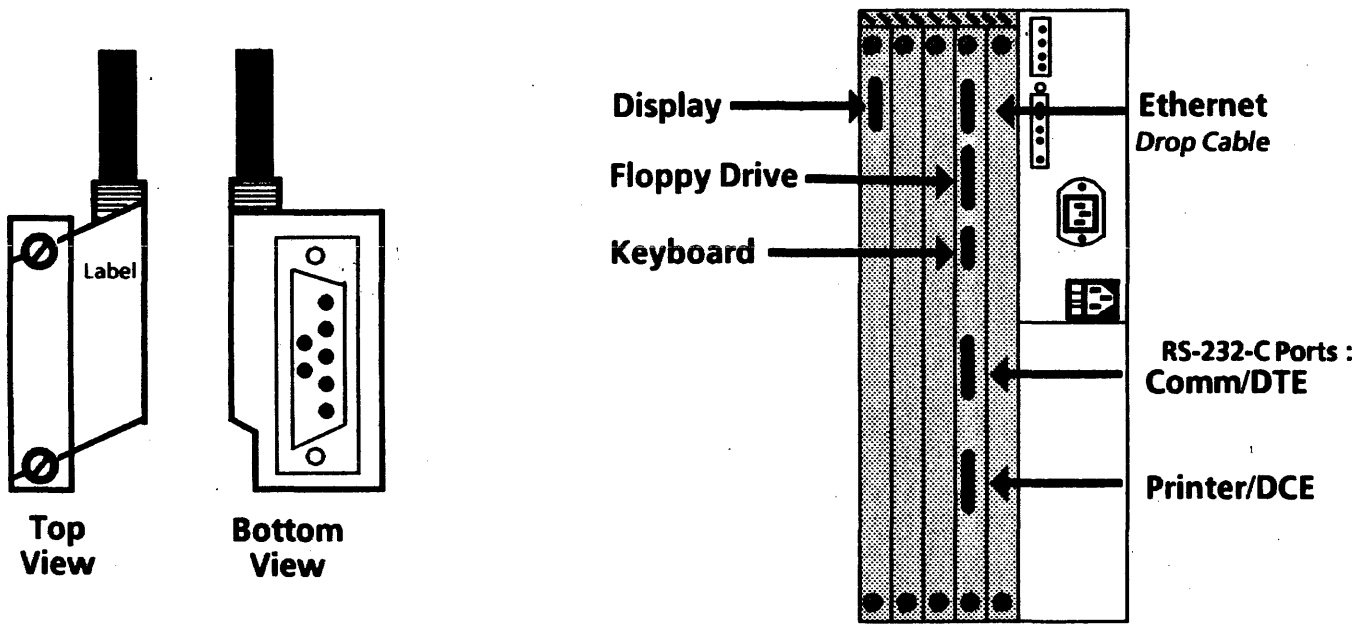

Figure 19. Connector Locations on Processor Unit Circuit Boards

## INSTALLATION PROCEDURES

4. Route the Display Power Cord (attached to the Display) through the opened Rear Cover and connect it to the Processor Unit.

**NOTE:** The illustration below does not accurately depict the location of the rear cover.

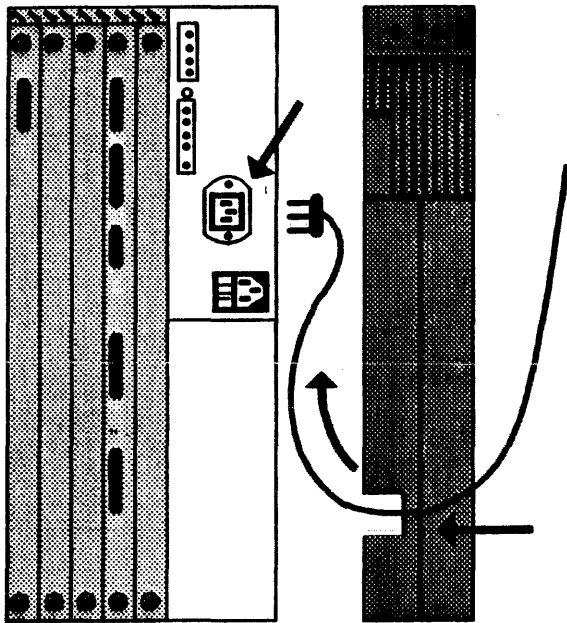

Figure 20. Connecting the Display Power Cord to the Processor Unit

5. Connect the Power Cord (packaged with the Processor Unit) to the Processor Unit and route it through the Rear Cover opening.
6. Locate the voltage switch to the left of the Power Cord plug. Ensure that the voltage switch is set to the appropriate voltage (US 115V).

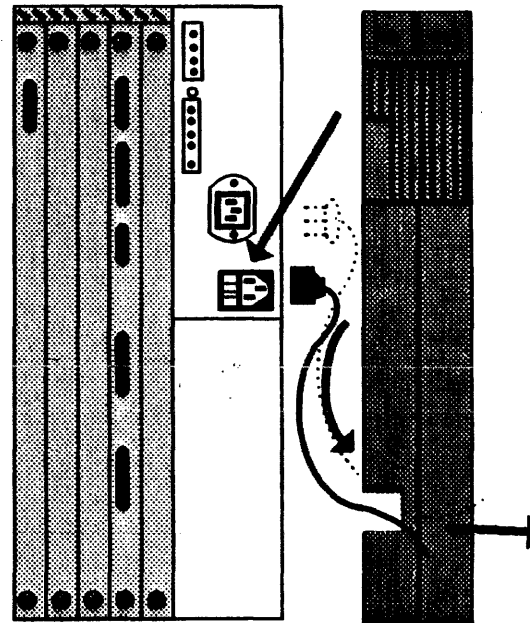

Figure 21. Connecting the Power Cord to the Processor Unit

**NOTE:** The illustration below does not accurately depict the location of the rear cover.

7. Close the Rear Cover of the Processor Unit.

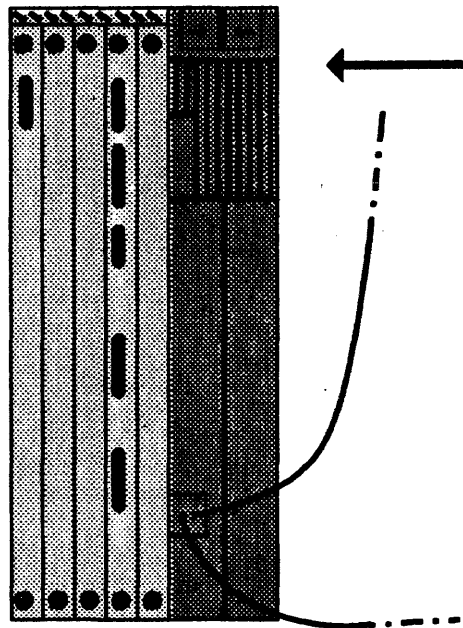

Figure 22. Closing the Processor Unit Rear Cover

### 6.8 SECURING THE CABLES

1. Unscrew the Cable Retention Bar at the bottom rear of the Processor Unit.

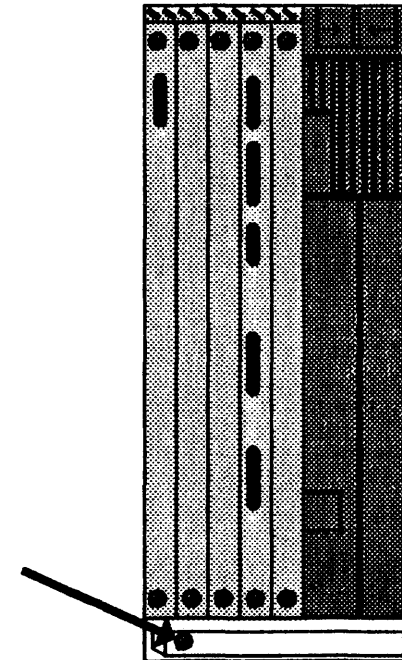

Figure 23. The Processor Unit Cable Retention Bar

## INSTALLATION PROCEDURES

---

2. Place all the cables beneath the Cable Retention Bar.

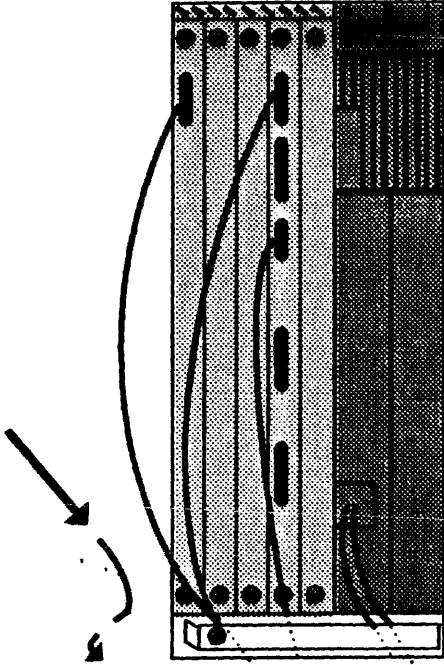

Figure 24. Placing the Cables Beneath the Cable Retention Bar

3. Screw the Cable Retention Bar back onto the Processor Unit.

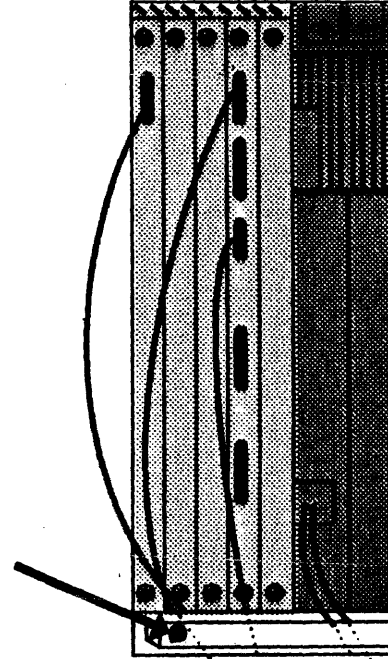
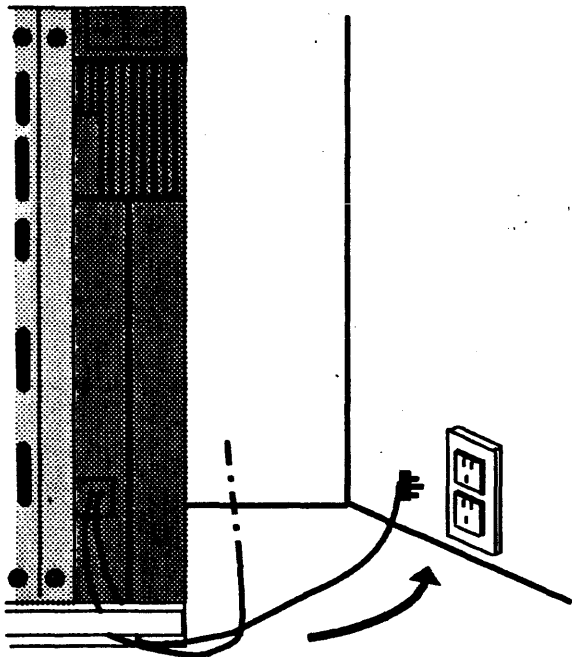

Figure 25. Securing the Cable Retention Bar



**6.9 POWERING UP THE SYSTEM**

1. Insert the end of the Power Cord into the wall outlet.



**Figure 26. Inserting the Power Cord Into the Wall Outlet**

2. Switch the power to ON at the Processor Unit. The screen should illuminate.

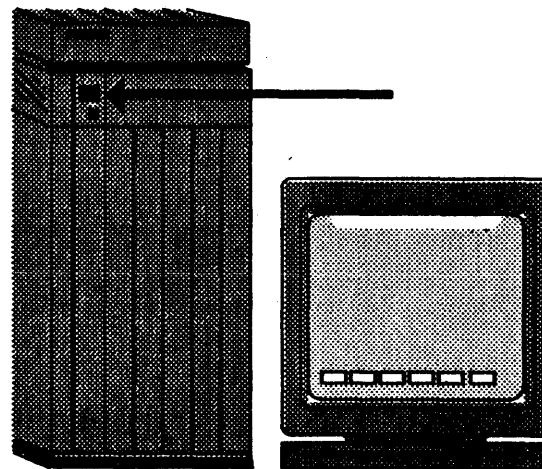

**Figure 27. Switching Power ON at the Processor Unit**

## INSTALLATION PROCEDURES

3. Swivel and tilt the screen to adjust it for your comfort. To adjust the screen intensity, turn the Brightness Control Knob, located behind the screen on the right side, as illustrated in Figure 28.

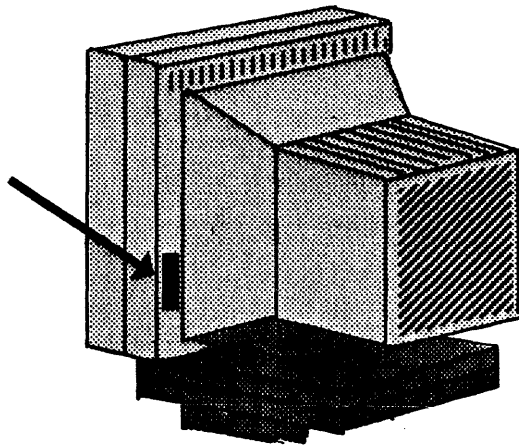

Figure 28. Adjusting the Brightness Control Knob

### 6.10 SYSTEM CONFIGURATION UTILITY

After installing the hardware, a description of this particular 6085's system configuration must be recorded on it's processor unit (for use by the software).

**Initial Configuration Data:** All 6085 PCS's are shipped with pre-set system configuration data in the processor unit. This initial (or pre-set) configuration assumes the following options:

1. Switch OFF system power and obtain model number from Rigid Disk Drive. Compare model number with size/model chart on page 6-33.
2. Switch ON system power.
3. Install the System Configuration Utilities floppy and press Function Key (F2) or press Function Key (F3) to boot the Utility from the Executive Menu.
  - a. Press any key to continue
  - b. Select 1, Normal User
  - c. Select 2, Show Configuration
  - d. The screen will display the following:  
Keyboard: U.S.  
Rigid Disk (model #)  
Memory: 1.1 MB  
Floppy Disk Drive?: Yes/No  
Ethernet Connection?: Yes/No  
PC Option?: Yes/No  
Automatic Diagnostics?: No

## INSTALLATION PROCEDURES

user's actual configuration, then you do not continue further with this section. Go to Procedure 6.11, **RUNNING DIAGNOSTICS**. Again, you will run the system configuration utility only if necessary (a PSR runs the utility as a *Normal User* only).

1. Power ON the processor.
2. Load the 6085 System Configuration Utility (from floppy disk or over the Ethernet network), press the F2 function key, and when prompted, press any key to continue.

**NOTE:** If the processor will not boot or if the boot device cannot be accessed, reboot while pressing the F9 function key. Some machines may run slow until the configuration has been properly stored and the processor powered OFF and then back ON.

3. Type the number corresponding to "*I am a Normal User,*" and press return.
4. Type the number corresponding to "*Set Configuration,*" and press return.
5. Type the number corresponding to "*U.S. Keyboard,*" and press return.

6. Select: appropriate rigid disk size/model.

**NOTE:** The size/model label is normally printed on the rigid disk cover assembly. Some early systems were not properly marked; in this case, the drive will have to be removed to view the manufacturer's name plate. Mark a blank label and affix it to the rigid disk cover assembly so that it can be viewed in the future without removal of the drive. The following cross reference should be used:

Seagate ST212 = 10Mb Rigid Disk - Model 1  
Tandom TM703 = 20Mb Rigid Disk - Model 1  
Tandom TM702 = 20Mb Rigid Disk - Model 2  
Seagate ST4026 = 20Mb Rigid Disk - Model 2  
Quantum Q530 = 20Mb Rigid Disk - Model 3  
Quantum Q540 = 40Mb Rigid Disk - Model 1  
Micropolis 1303 = 40Mb Rigid Disk - Model 2  
Micropolis 1325 = 80Mb Rigid Disk - Model 1

7. Select: the memory size (i.e., *Memory: 1.1MB*).
8. Type Y or N if you have a Floppy Drive or not.
9. Type Y or N if you are connected to an Ethernet network or not.
10. Type Y or N if you have the PC Option or not.
11. Type N to Automatic Diagnostics.

## INSTALLATION PROCEDURES

---

12. Type **Y** to "Do you want your workstation reconfigured with the options you have selected?" and to "Please confirm?"

13. Press **RETURN** twice to get back to the Logon.

### 6.11 RUNNING DIAGNOSTICS

1. Run diagnostics.
  - a. Insert the floppy disk labeled "Boot Diagnostics" into the Floppy Disk Drive.
  - b. Press **B RESET** on the Processor Unit.
  - c. Press the **F6** function key twice to run the Long Boot Diagnostics.

**NOTE:** Long Boot Diagnostics take approximately 18 minutes to run. If diagnostics run successfully, the softkeys return to the screen.

2. Insert the floppy disk labeled "Rigid Disk Diagnostics" into the floppy disk drive and press the **F2** function key.
  - Type the number corresponding to "I am a Normal User," and press return.

- Run Confidence Test (3 passes). Confidence Test passed.

**YES** ↓    **NO** → If the failure code was 1, 2, or 3, replace the IOP PWBA (PI 3.1) and return to Step 1. If it was any other number, write it down and call for assistance.

### 6.12 INSTALLATION CHECKLIST

- Are all the circuit boards properly secured?
- Are all the cables properly connected?
- Has the cardboard shipping disk been removed from the Floppy Disk Drive?
- Have you adjusted the Display's brightness control knob?
- Have you run the System Configuration Utility?
- Have you run diagnostics?
- Have you run the rigid disk confidence test?

If the screen still does not illuminate, you may have a hardware problem. Call for assistance.

### **6.13 TYPES OF WORKSTATIONS**

There are three types of 6085 workstations: Network, Remote, and Standalone. In order to ensure correct installation procedures are used, workstation types must be determined before software installation is attempted.

The following is a brief description of the three workstation types and the recommended software installation procedures to be followed. Before installing software, determine the type of workstation you have, and the software installation procedures you will use.

#### **6.13.1 NETWORKED WORKSTATIONS**

Network workstations are connected directly to the Ethernet network via a drop cable and transceiver.

Both ViewPoint and VP Applications software can be installed either from floppy disks or through network installation.

Consult with the System Administrator to confirm network installation is available, and request the location of the "Installation Drawer."

#### **6.13.2 REMOTE WORKSTATIONS**

Remote workstations (with RS-232-C interfaces) can communicate with a network via a modem and communication lines.

ViewPoint software must be installed from floppy disks. VP Applications software, however, may be installed either from floppy disks or through network installation.

Consult with the System Administrator to confirm network installation is available, and request the location of the "Installation Drawer."

#### **6.13.3 STANDALONE WORKSTATIONS**

Standalone workstations are not connected to the network in any way.

Both ViewPoint and VP Applications software must be installed from floppy disks.

## INSTALLATION PROCEDURES

---

### 6.14 SOFTWARE INSTALLATION FROM FLOPPY

This section describes how to install Xerox ViewPoint software on a 6085 workstation using floppy disks. The installation instructions that follow apply to Networked, Remote, and Standalone 6085 workstations.

#### WARNING

The following installation procedures destroys all desktops resident on the workstation. Therefore, all data files must be stored on floppy disks or in a file drawer prior to software installation.

It is recommended that new desktops be created after software installation. For this reason it is desirable to store data files on floppy disks or in file drawers rather than entire desktops on file servers.

#### 6.14.1 INSTALLATION INSTRUCTIONS

1. Place the floppy disk labeled "6085 Xerox ViewPoint Installer #1" in the floppy disk drive of the 6085 workstation.
2. Press the B RESET button on the processor's front panel.

3. Press the F2 function key on the keyboard when the boot softkeys appear on the screen. After a few moments, you will be requested to "Insert floppy disk labeled 6085 ViewPoint Installer #2" in the floppy drive. A list of installation options appear.
4. Insert the floppy disk labeled "6085 Xerox ViewPoint Installer #2" in the floppy drive and press return to confirm the floppy disk is inserted.

**Comment:** If general information about installation is desired, type the number corresponding to the "HOW TO USE THE INSTALLER" option and press return.

Partitioning prepares the workstation rigid disk to receive and store data. It divides space on the rigid disk into "logical volumes," each with a specific purpose. This step is used during initial installation, when new ViewPoint software is released, if you have a new workstation disk, or if error recovery procedures indicate it is required.

5. Type the number corresponding to the "ViewPoint: 6085 Partition Workstation Disk" option and press return. Additional options appear.

## INSTALLATION PROCEDURES

6. Type the number corresponding to the "Partition 6085 Workstation Disk" option and press return. The following message appears:  
**"WARNING - PARTITIONING DESTROYS ALL DESKTOPS AND OTHER DATA ON THE WORKSTATION DISK!!!"**  
*Partition only if you are installing ViewPoint on a 6085 for the first time, have a new workstation disk, or if error recovery procedures indicate it is required. Store all desktop data on floppies or at a server before partitioning.*  
Confirm? (Y/N):"
7. Type y and press return if all files have been stored on floppy disks or in file drawers. A second confirmation appears:  
**"ALL DESKTOPS ON WORKSTATION WILL BE DESTROYED. Are you sure you wish to continue?"**  
Confirm? (Y/N):"
8. Type y if all files have been stored on floppy disks or in file drawers.

**NOTE:** Partitioning may take several minutes.

After partitioning is complete, the message "Disk partitioned" appears, followed by additional options.

9. Type the number corresponding to the "Return to MAIN MENU" option and press return. The installation options appear.

ViewPoint and other essential software is copied to the rigid disk of the workstation being installed. This step is used during initial install, and when new ViewPoint software is released.

10. Type the number corresponding to "ViewPoint: 6085 Install ViewPoint Software on Workstation (from floppies)" option and press return. Additional options appear.
11. Type the number for the option that corresponds to the type of workstation (network, remote, or standalone) for which software is being installed.
  - If software is being installed for a **Networked Workstation** (directly connected to the network), type the number corresponding to the "Install NETWORK 6085 WORKSTATION with ViewPoint, VP NetCom, and VP Document Editor" option.
  - If software is being installed for a **Remote Workstation** (connected to a network via a modem and communication lines), type the number corresponding to the "Install REMOTE COMMUNICATING WORKSTATION with

## INSTALLATION PROCEDURES

---

ViewPoint, VP RemoteCom, and VP Document Editor" option.

- If software is being installed for a **Standalone Workstation** (no connection to a network), type the number corresponding to the "Install **STANDALONE WORKSTATION** with ViewPoint, VP StandAlone, and VP Document Editor" option.

12. Press return. A confirmation message appears.
13. Type **y** and press return to confirm that you are ready to proceed.
14. Follow the prompts and insert the floppy disks as requested by the system. The system will prompt you for the floppy disks in the appropriate order.

**Comment:** After installation of ViewPoint, VP NetCom, RemoteCom or StandAlone and VP Document Editor is completed, additional options appear. . . .

15. Type the number corresponding to the "Start **6085 System**" option and press return.
16. Remove the last floppy disk from the floppy disk drive.
17. Press the **F1** function key when the boot softkeys appear on the screen.

18. Press **I** and **V** simultaneously for 1 second when the **7504** code appears. During start-up time the following MP codes may appear for an extended period of time: **7600**, **7700**, and **7800**. After approximately 15 minutes the bouncing keyboard appears on the screen, indicating that ViewPoint software has been installed and successfully started.

**NOTE:** If either a **7501** or **7511** code appears, the file check software is not loaded. To load the boot file, complete the following steps:

- a) Insert the floppy disk labeled "**6085 Xerox ViewPoint: Installer #1**" and boot the workstation by pressing the **F2** function key on the keyboard.
- b) Type the number corresponding to the "**ViewPoint: 6085 Special Installation and Error Recovery Commands**" option and press return.
- c) Type the number corresponding to the "**Install File Check**" option and press return.
- d) Insert the floppy disk labeled "**6085 Xerox ViewPoint: File Check**" when prompted by the system. A message appears indicating that the installation of file check is complete.



## INSTALLATION PROCEDURES

---

- e) Type the number corresponding to the "Run File Check" option and press return. A message appears indicating that file check should not be started unless Xerox ViewPoint has been previously installed and start-up has been attempted.

**NOTE:** If Xerox ViewPoint has not been previously installed and start-up attempted, install Xerox ViewPoint using the procedure described in this section.

- f) Type **y** to confirm. A second confirmation is required.
- g) Type **y** for the second confirmation. The 7500 code appears indicating that file check is properly running. Upon completion the system automatically starts up and the bouncing keyboard appears.

- 19. The system is now ready to install VP Series applications and font software. Refer to Procedure 6.14.2 for complete installation instructions.

**NOTE:** During initial installation, installed software is available for use for 72 hours. Within this time period all

software options must be enabled using the software options tool. If software options are not enabled within the allotted time, they will no longer be available for use. The 72 hour grace period is provided to allow your customer to enable software options at their leisure. Optional software installed at a later date does not have the 72 hour grace period.

- 20. Installation procedures are not complete until software is enabled. Your customer can refer to the sub-tab titled "Software Options Tool" in the VP Series Reference Library for complete procedures on enabling software options.

## INSTALLATION PROCEDURES

---

### 6.14.2 VP SERIES APPLICATIONS INSTALLATION

This section describes how to install VP Series application software on a workstation using floppy disks. The installation instructions that follow apply to Networked, Remote, and Standalone workstations.

1. Press any key to display the logon option sheet.
2. Have the user type his/her fully-qualified user name (i.e., user name:domain name:organization name), and press next.
3. Have the user type his/her password and press next. After a few moments the desktop appears.
4. Select the directory icon and press open.
5. Select the workstation divider in the directory window and press open.
6. Select the local devices divider and press open.
7. Select the floppy disk icon, press copy, and select a destination on the desktop.
8. Select [CLOSE] to close the local devices divider.
9. Select the loader icon, press copy, and select a destination on the desktop.
10. Select [CLOSE ALL] to close the directory window.
11. Insert the desired VP Series application disk in the floppy disk drive of the workstation.
12. Select the Floppy Disk icon and press open to display the floppy disk window.

To install the software on the workstation's rigid disk, the application or font must be copied from the Floppy disk icon to the Loader icon on the desktop.

13. Select the VP application in the floppy disk window, press copy, and select the Loader icon as the destination. A message appears in the desktop message area indicating that the VP application is being copied, loaded, and started.
14. Repeat steps 11 through 13 for each VP Series application that is to be installed on the workstation.

**NOTE:** If fonts or data driven graphics are installed, the workstation must be rebooted, by pressing the F1 function key, in order to initialize them, even though the application loader will indicate that they are installed and running.

The sub-tab titled "Application Loader" in the VP Series Reference Library contains complete information on the Loader Icon.

**NOTE:** During initial installation, installed software is available for use for 72 hours. Within this time period all software options must be enabled using the software

options tool. If software options are not enabled within the allotted time, they will no longer be available for use. The 72 hour grace period is provided to allow your customer to enable software options at their leisure. Optional software installed at a later date does not have the 72 hour grace period.

15. Installation procedures are not complete until software is enabled. To continue installation, your customer can refer to the sub-tab titled "Software Options Tool" in the VP Series Reference Library for information on enabling software options.

### **6.15 SOFTWARE INSTALLATION FROM THE NETWORK**

This section describes how to install Xerox ViewPoint software on a 6085 workstation over the network. The installation instructions that follow apply to Networked 6085 workstations only. Remote and Standalone 6085 workstations cannot be loaded through network installation.

### **WARNING**

The following installation procedures destroys all desktops resident on the workstation. Therefore, all data files must be stored on floppy disks or in a file drawer prior to software installation.

It is recommended that new desktops be created after software installation. For this reason it is desirable to store data files on floppy disks or in file drawers rather than entire desktops on file servers.

### **6.15.1 INSTALLATION INSTRUCTIONS**

**NOTE:** A workstation must have a minimum of 768 kilobytes of memory to install software over the network.

1. Verify with the System Administrator that the Boot Service is installed and running before attempting to install software over the network.
2. Press the B RESET button on the processor's front panel.
3. Press the F3 function key on the keyboard when the boot softkeys appear on the screen.

## INSTALLATION PROCEDURES

---

A series of numbers, called MP (maintenance panel) codes, begin to cycle in the upper lefthand corner of the screen. After a few moments the message "Logon please" appears.

**NOTE:** If the MP codes are not displayed within 2 minutes, press the B RESET button again. If the MP codes are still not displayed within 2 minutes contact the System Administrator.

4. Select 2, Installer
5. Have the user type his/her fully qualified name (user name:domain:organization) and press return. The message "Password" appears.

**NOTE:** If a fully-qualified name is not entered, the message "Domain and organization required for logon" displays along with the available domain and organization options. Type the number corresponding to the appropriate domain and organization, and press return.

6. Have the user type his/her password and press return. In a few moments the main menu is displayed.

**NOTE:** If the user does not know their fully-qualified name (name:domain:organization), have them contact their System Administrator.

**NOTE:** Accented characters cannot be used to log on during initial installation. If the user's name or password contains accented characters, ask the System Administrator to create an alias name and/or password without accented characters for use during installation.

**Comment:** If general information about installation is desired, type the number corresponding to the "HOW TO USE THE INSTALLER" option and press return.

Partitioning prepares your workstation rigid disk to receive and store data. It divides space on the rigid disk into "logical volumes," each with a specific purpose. This step is used during initial installation, when new ViewPoint software is released, if you have a new workstation disk, or if error recovery procedures indicate it is required.

7. Type the number corresponding to the "ViewPoint: 6085 Partition Workstation Disk"

option and press return. Additional options appear.

8. Type the number corresponding to the "Partition 6085 Workstation Disk" option and press return. The following message appears:

**"WARNING - PARTITIONING DESTROYS ALL DESKTOPS AND OTHER DATA ON THE WORKSTATION DISK!!"**

*Partition only if you are installing ViewPoint on a 6085 for the first time, have a new workstation disk, or if error recovery procedures indicate it is required. Store all desktop data on floppies or at a server before partitioning.*

*Confirm? (Y/N):"*

9. Type **y** and press return if all files have been stored on floppy disks or a file drawer. A second confirmation appears:

**"ALL DESKTOPS ON WORKSTATION WILL BE DESTROYED.**

*Are you sure you wish to continue?*

*Confirm? (Y/N):"*

10. Type **y** and press return if all data files have been stored on floppy disks or in file drawers.

**NOTE:** Partitioning may take several minutes.

After partitioning is complete, the message "Disk partitioned" appears, followed by additional options.

ViewPoint and other essential software is copied to the rigid disk of the workstation being installed. This step is used during initial installation, and when new ViewPoint software is released.

11. Type the number corresponding to the "Return to MAIN MENU" and press return. Installation options appear.
12. Type the number corresponding to "ViewPoint: 6085 Install ViewPoint Software" option and press return. Additional options appear.
13. Type the number corresponding to the "Install NETWORK 6085 WORKSTATION with ViewPoint, VP NetCom, and VP Document Editor" option and press return. A confirmation message appears.
14. Type **y** and press return to confirm that you are ready to proceed.

**NOTE:** Software installation takes approximately 20-30 minutes. Messages advising you that installation is continuing appear periodically.

## INSTALLATION PROCEDURES

---

15. Type the number corresponding to the "Start 6085 System" option and press return.
16. Type **y** and press return to confirm that you are ready to proceed.
17. Press the F1 function key when the boot softkeys appear on the screen.
18. Press **I** and **V** simultaneously for 1 second when the 7504 code appears. During start-up times, the following MP codes may appear for an extended period of time: 7600, 7700, and 7800. After approximately 15 minutes, the bouncing keyboard will appear on the screen, indicating that ViewPoint software has been installed and successfully started.

**NOTE:** If either a 7501 or a 7511 code appears, the file check software is not loaded. To load the boot file, complete the following steps:

- a) Press the B RESET button on the processor's front panel.
- b) Press the F3 function key on the keyboard. The MP codes will begin to cycle on the screen. After a few moments the message "Logon please (with fully qualified name)" appears.
- c) Have the user type his/her fully qualified name (user name:domain:organization) and press return. The message "Password" appears.

- d) Have the user type his/her password and press return.

**NOTE:** If the user does not know his or her fully-qualified name, contact the System Administrator.

- e) Type the number corresponding to the "ViewPoint: 6085 Special Installation and Error Recovery Commands" option and press return.
- f) Type the number corresponding to the "Install File Check" option and press return. A message appears indicating that the installation of file check is complete.
- g) Type the number corresponding to the "Run File Check" option and press return. A message appears indicating that file check should not be started unless Xerox ViewPoint has been previously installed and start-up has been attempted.

**NOTE:** If Xerox ViewPoint has not been previously installed and start-up attempted, install Xerox ViewPoint using the procedure described in this section.

- h) Type **y** and press return to confirm. A second confirmation is required.

- i) Type **y** and press return for the second confirmation. The 7500 code appears indicating that file check is properly running. Upon completion, the system automatically starts up and the bouncing keyboard appears.

- 19. The system is now ready to install VP Series applications and font software. Refer to Procedure 6.15.2 for complete installation instructions.

**NOTE:** During initial installation, installed software is available for use for 72 hours. Within this time period all software options must be enabled using the software options tool. If software options are not enabled within the allotted time, they will no longer be available for use. The 72 hour grace period is provided to allow your customer to enable software options at their leisure. Optional software installed at a later date does not have the 72 hour grace period.

- 20. Installation procedures are not complete until software is enabled. Your customer can refer to the sub-tab titled "Software Options Tool" in the VP Series Reference Library for complete procedures on enabling software options.

### 6.15.2 VP SERIES APPLICATIONS INSTALLATION

This section describes how to install VP Services applications and font software on a workstation over the network. The installation instructions that follow apply only to workstation attached to the network, directly or via a modem.

The software for each VP application or font is stored in the VP Applications Drawer. Ask the System Administrator for the exact location of the Installation Drawer before attempting installation of application software.

1. Press any key to display the logon option sheet.
2. Have the user type his/her fully-qualified user name (i.e., user name:domain name:organization name), and press next.
3. Have the user type his/her password and press next. After a few moments the desktop appears.
4. Select the directory icon and press open.
5. Open the workstation divider in the directory window copy the loader icon onto the desktop.
6. Close the Workstation divider icon. (The first level of the directory window should now be displayed.)

## INSTALLATION PROCEDURES

---

7. Open the Network divider icon and locate the desired File Server, by opening the appropriate organization, domain, and filing divider icons.
8. Open the File Server divider icon and copy the file drawer labeled "VP Applications Drawer" to the desktop.

To install the software on the workstation's rigid disk, the application or font must be copied from the VP Applications Drawer to the loader icon on the desktop.

9. Open the "VP Application Drawer" icon.
10. Select the desired VP application or font, press copy, and select the loader icon as the destination. A message appears in the desktop message area indicating that the VP application is being copied, loaded, and started.
11. Repeat step 10 for each VP Series application or font that is to be installed on the workstation.

**NOTE:** If fonts or data driven graphics are installed, the workstation must be rebooted, by pressing the F1 function key, in order to initialize them, even though the application loader will indicate that they are installed and running.

The sub-tab titled "Application Loader" in the VP Series Reference Library contains complete information on the Loader icon.

**NOTE:** During initial installation, installed software is available for use for 72 hours. Within this time period all software options must be enabled using the software options tool. If software options are not enabled within the allotted time, they will no longer be available for use. The 72 hour grace period is provided to allow your customer to enable software options at their leisure. Optional software installed at a later date does not have the 72 hour grace period.

12. Installation procedures are not completed until software is enabled. To continue the installation, your customer can refer to the sub-tab titled "Software Options Tool" in the VP Series Reference Library for information on enabling software options.



**CHAPTER 7 WIRING DATA**  
**6085 Product Support Manual**

## WIRING DATA

### WIRING DATA

The 6085 Professional Computer System has no internal wire harnesses. The PWBAs plug directly into the backplane. All connections are made either through the backplane or at the rear of the machine through cables or power cords. At this time there are no tests that can be made at the backplane.

Plug/Jack locations are shown in figure 7-1.

Wiring data is shown in figures 7-2 through 7-7.

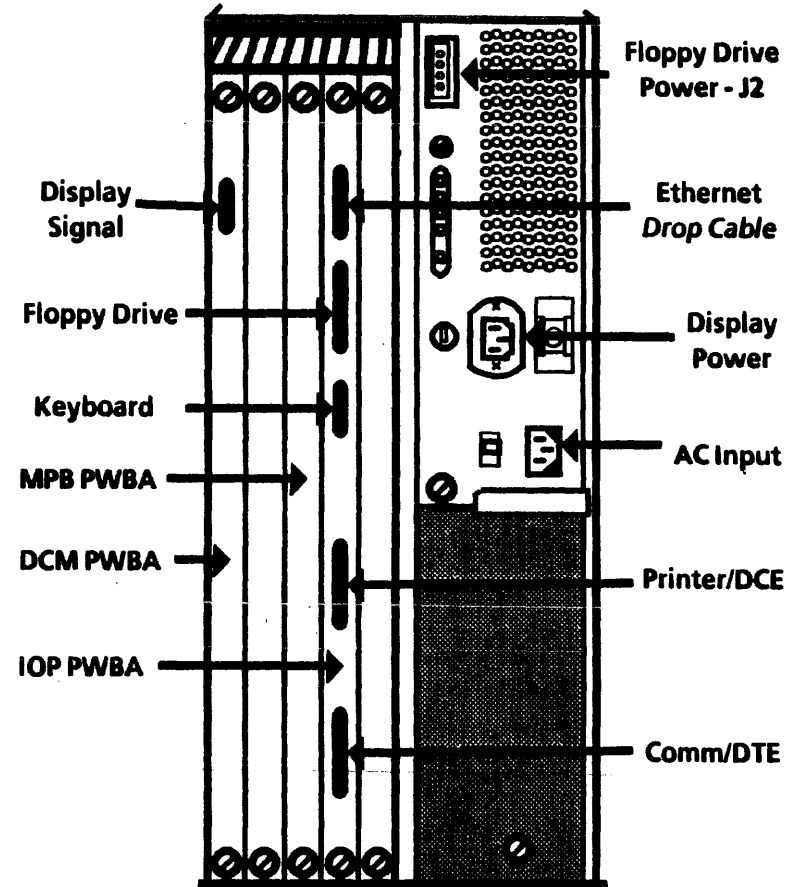

Figure 7-1 6085 PCS (Rear) Plug/Jack Locations

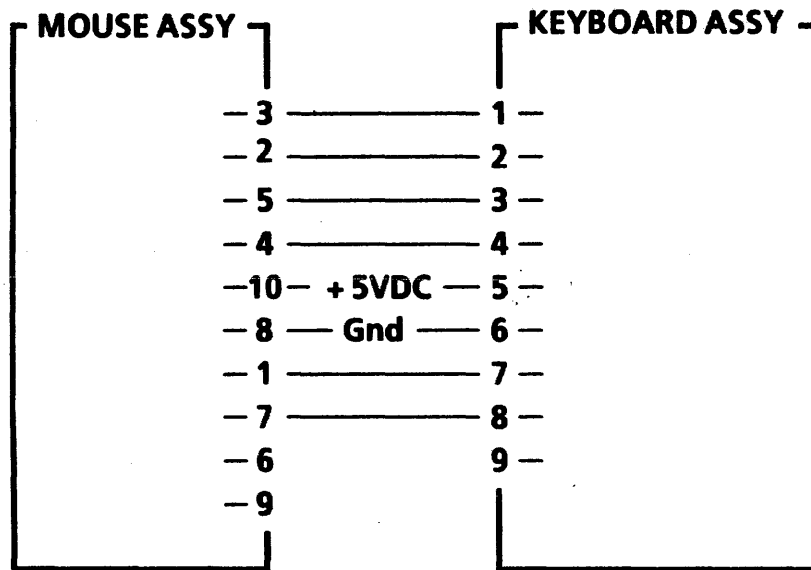

Figure 7-2 Mouse/Keyboard

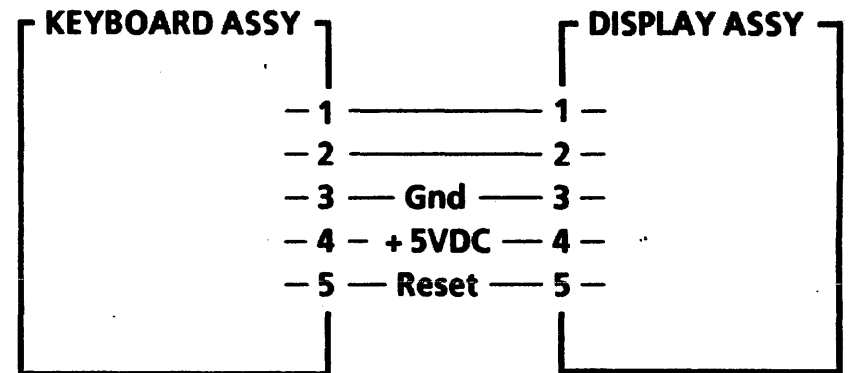

Figure 7-3 Keyboard/Display

**WIRING DATA**

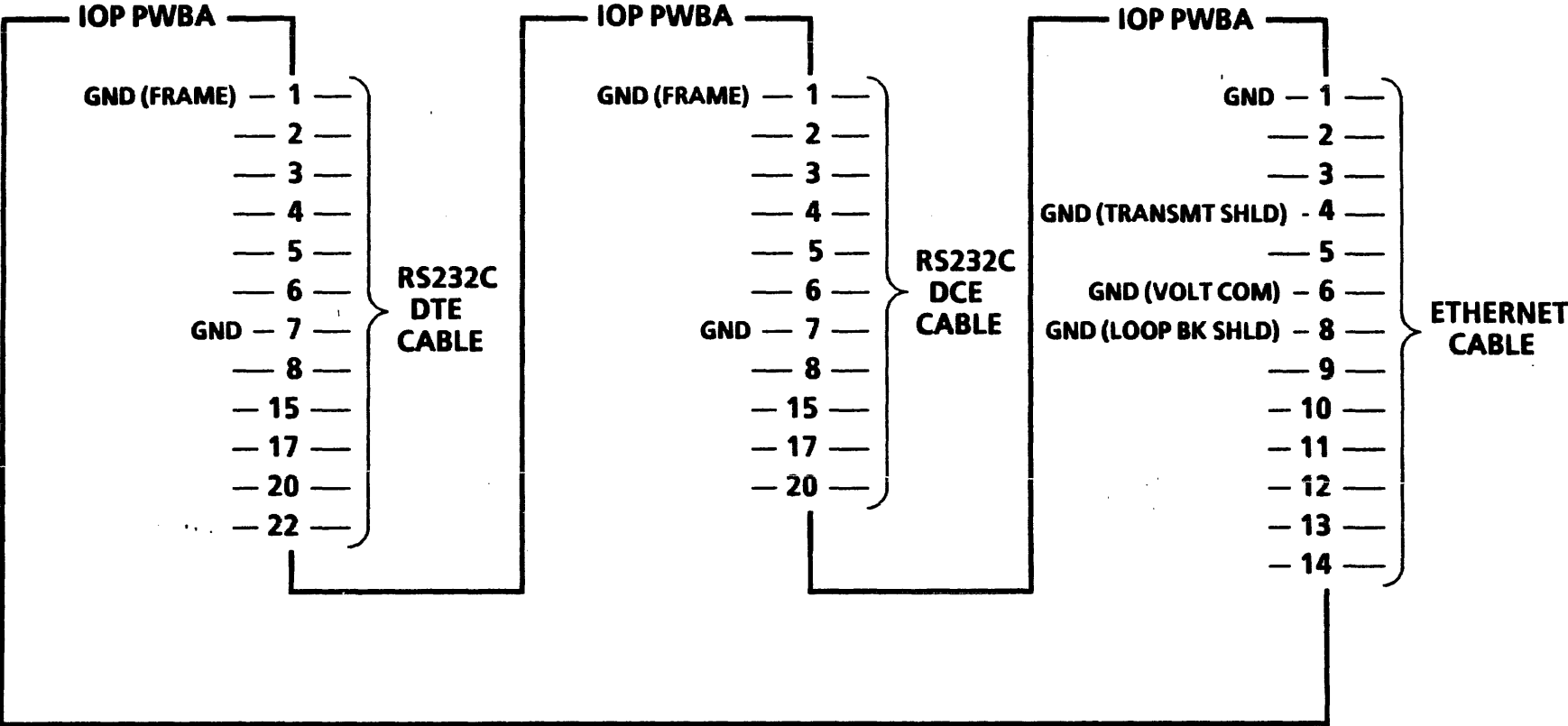

Figure 7-4 IOP PWBA

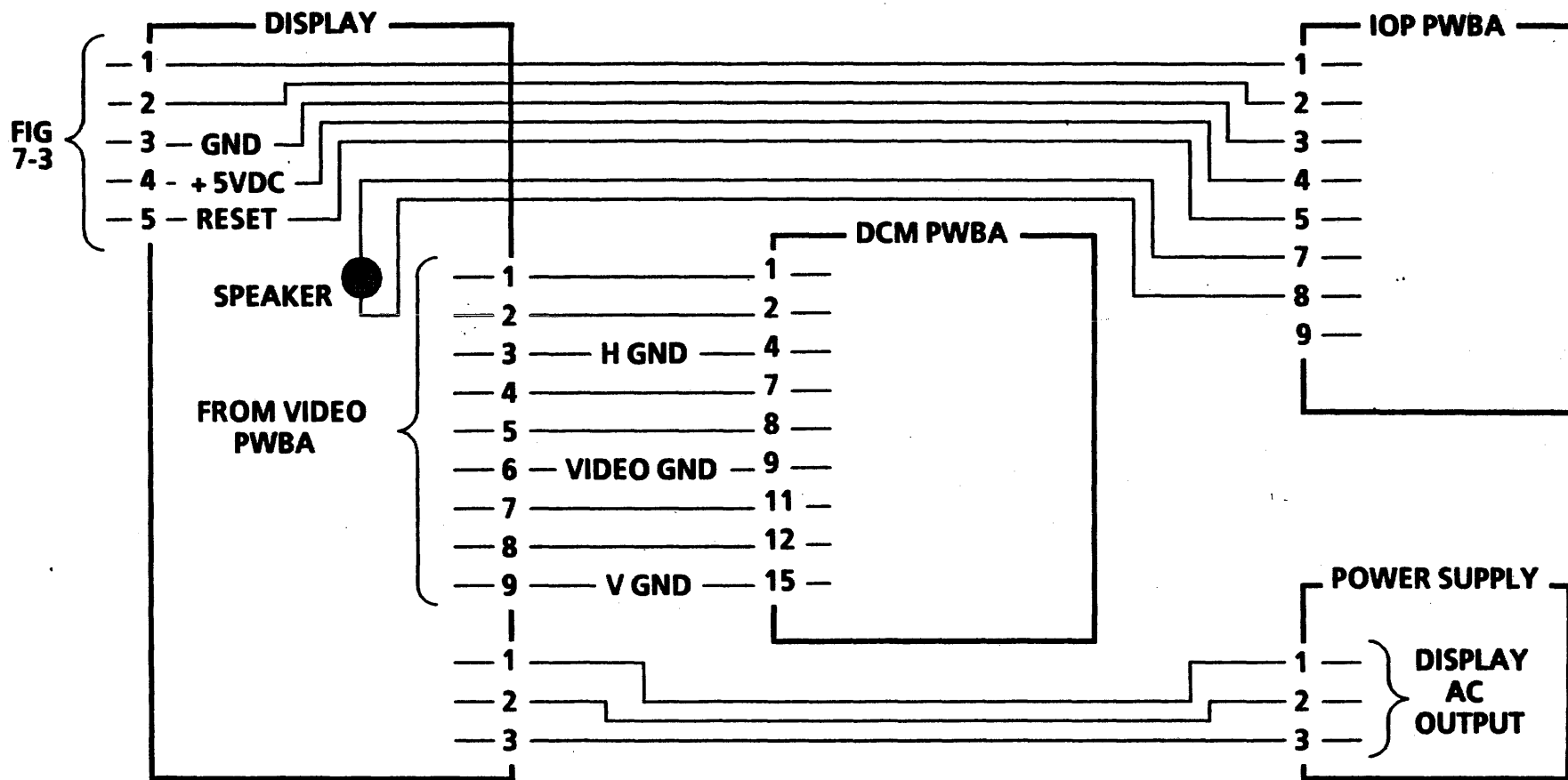

Figure 7-5 Display

**WIRING DATA**

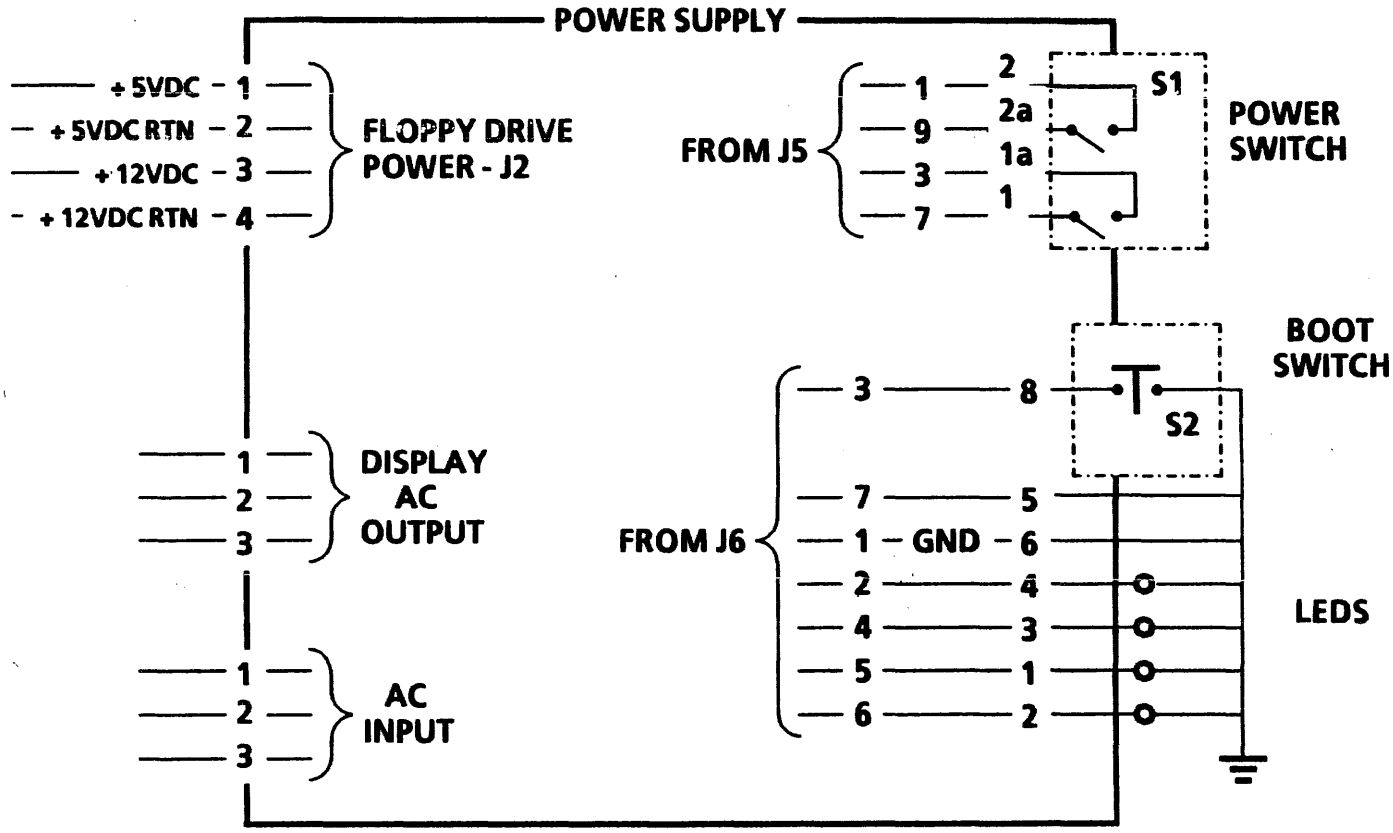
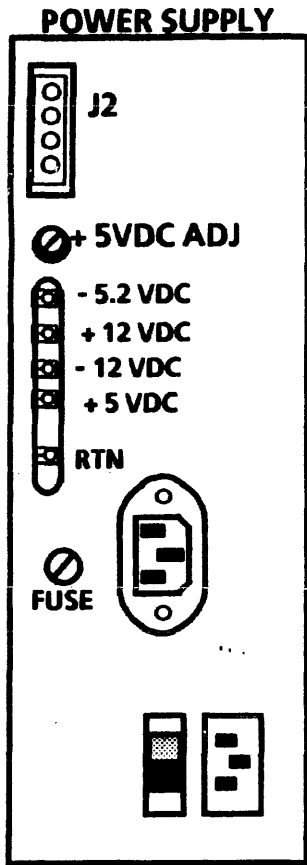

Figure 7-6 Power Supply

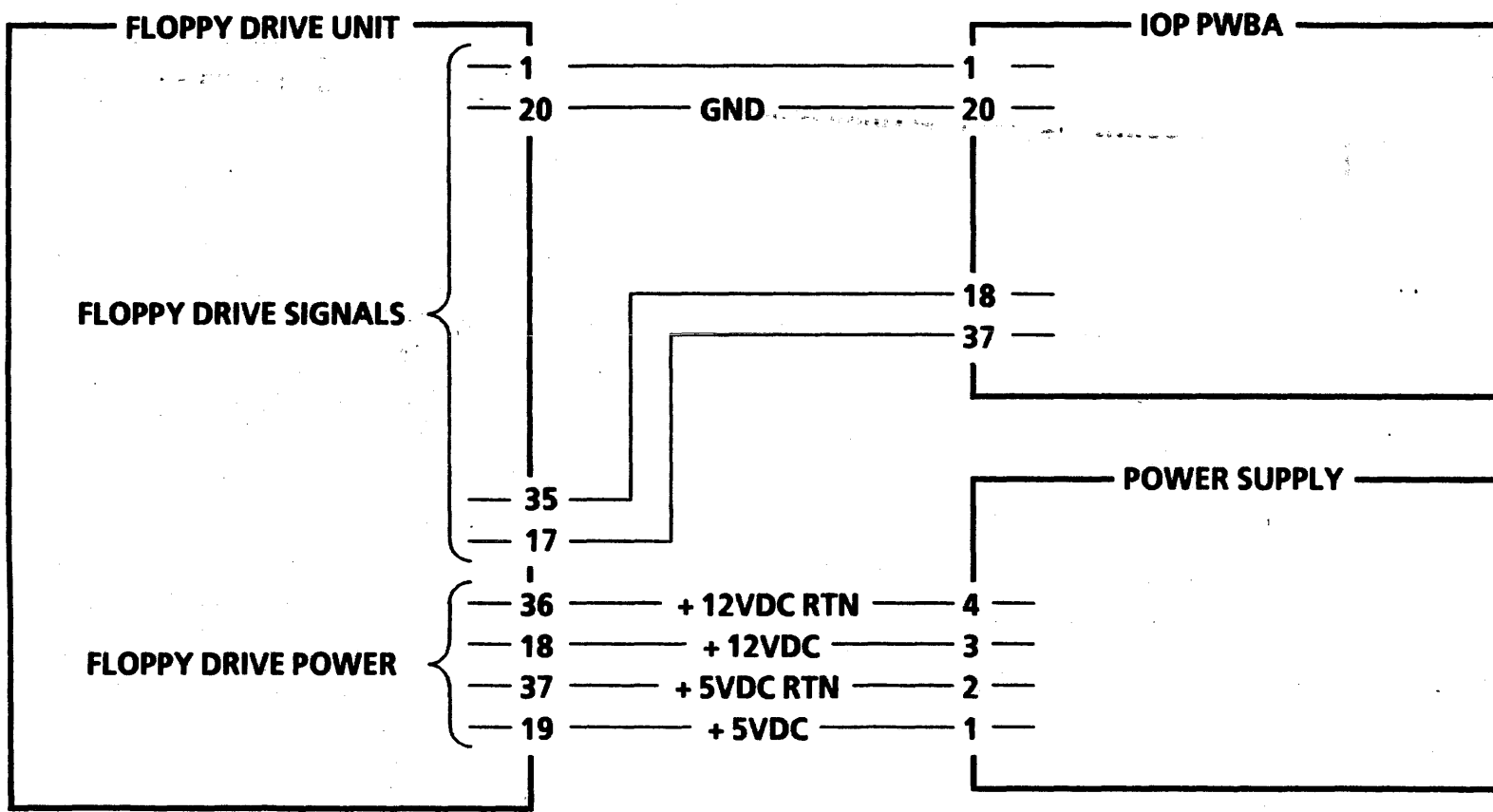

Figure 7-7 Floppy Drive

**MIRING DATA**

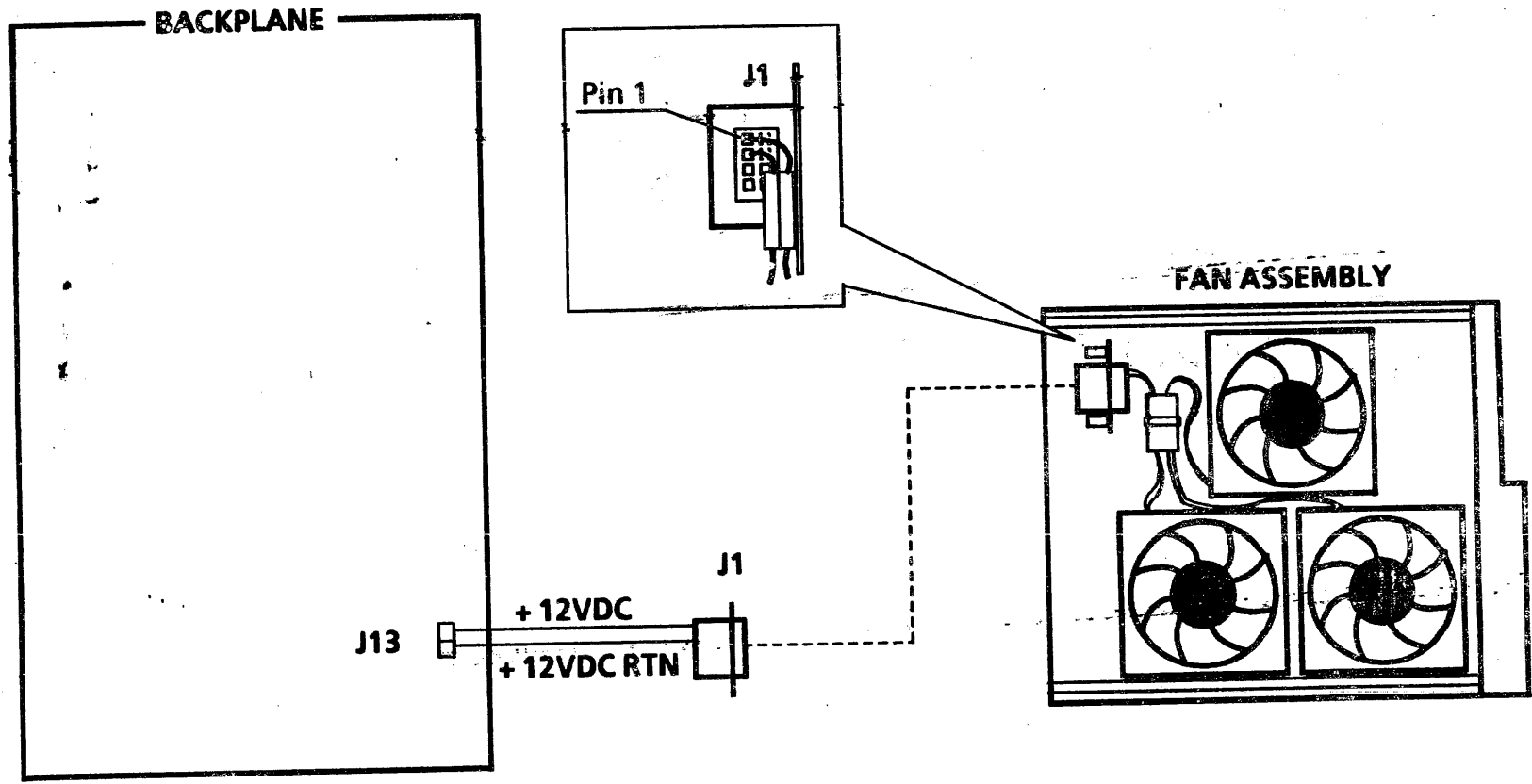

Figure 7-8 Fans



**FLOPPY DISK DRIVE**

The Floppy Disk Drive is a dual sided, dual density drive. Control signals from the Floppy Disk Controller circuitry on the IOP PWBA are received through the interface cable. These control signals select the appropriate side of the disk, control the head stepper motor, control the head load solenoid, and select read or write modes. The data signals are the read or write data that is to be recorded or read from the Floppy Disk.

The Floppy Disk Drive sends the following status information through the Floppy Disk Drive cable to the Floppy Disk Controller circuitry on the IOP PWBA:

- Ready (Floppy Disk loaded and at speed)
- Index (Index hole sensed)
- Track 00 (Read/Write Head positioned on Track 00)
- Write Protect (Write protected disk loaded in the drive)

The DC voltages (+5VDC, +12VDC, and GND) are supplied by the power supply through the Floppy Disk Drive power cord.

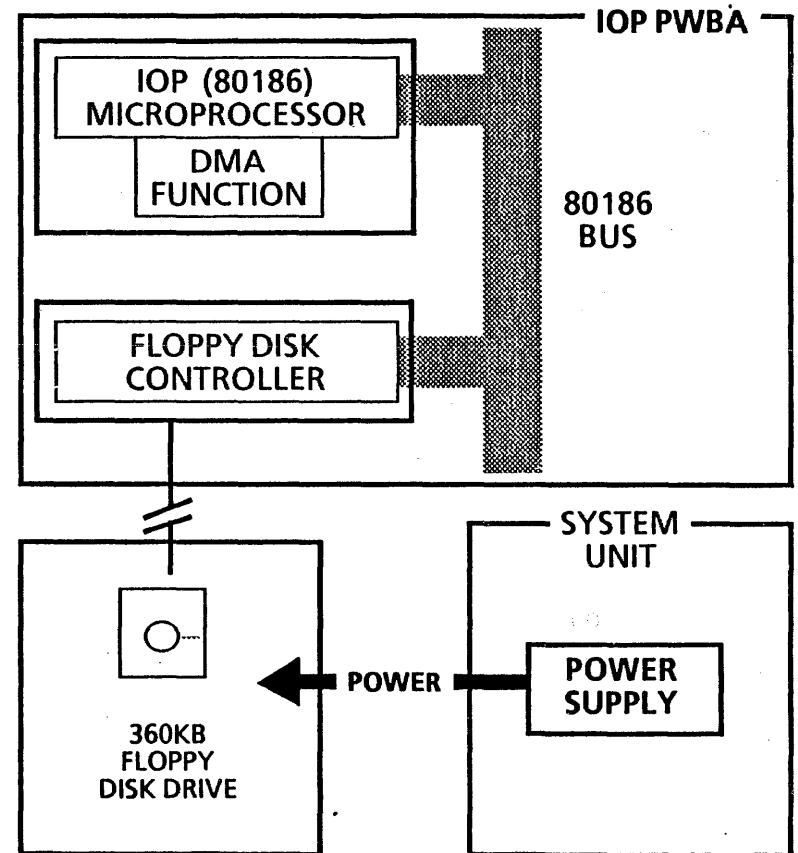

Figure 8.5 Floppy disk subsystem block diagram

## PRINCIPLES OF OPERATION

---

### ETHERNET CONNECTOR

The Ethernet connector provides a means of attaching the 6085 to a 50 ohm Ethernet cable through a drop cable and transceiver.