

TC-30 STREAMER TAPE ADAPTER

LOGIC MANUAL



(This page intentionally left blank.)

TC-30 STREAMER TAPE ADAPTER

LOGIC MANUAL

Preliminary

WESTERN PERIPHERALS
14321 New Myford Road
Tustin, California 92680

(714) 730-6250

(This page intentionally left blank.)

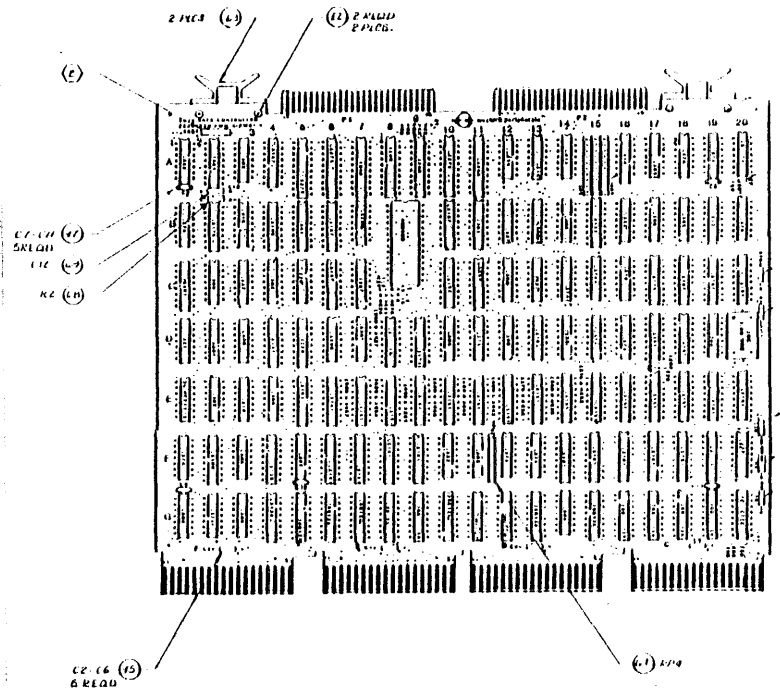

- (1) 477, 472, 473
- (2) 19, 215-260
- (3)
- (4)
- (5)
- (6)
- (7)
- (8)
- (9)
- (10)
- (11)
- (12)
- (13)
- (14)
- (15)

NOTES: UNLESS OTHERWISE SPECIFIED
 (1) FOR MATERIAL SEE DFM P0000000 RLV A
 (2) ADKS WITH ASSY AS AND LATEST REV LTR APPROX WORK DRAWING
 3 DIM. HEIGHT OF COMPONENTS FROM HOLE SURFACE AND TO EXCEED .001
 4 REF. SCHEMATIC 150000000, REV A.

QTY	ASSEMBLY	PART OR IDENTIFYING NO.	QUANTITY	DATE
1	1	1	1	11/177
UNLESS OTHERWISE SPECIFIED DIMENSIONS ARE IN INCHES FRACTIONS AND DECIMALS ARE TO EXCEED .001		PARTS 1151		
MATERIAL	DESCRIPTION	APPROVAL	DATE	
(1)	ASSY - T30 TAPE CONTROLLER	WESTERN PERIPHERALS	11/177	
DRAWN BY: [Signature]		DATE: 11/177		
CHECKED BY: [Signature]		DATE: 11/177		
APPROVED BY: [Signature]		DATE: 11/177		
PARTS LIST		PARTS 1151		
PART NO.		QUANTITY		
1		1		
DATE		DATE		
11/177		11/177		

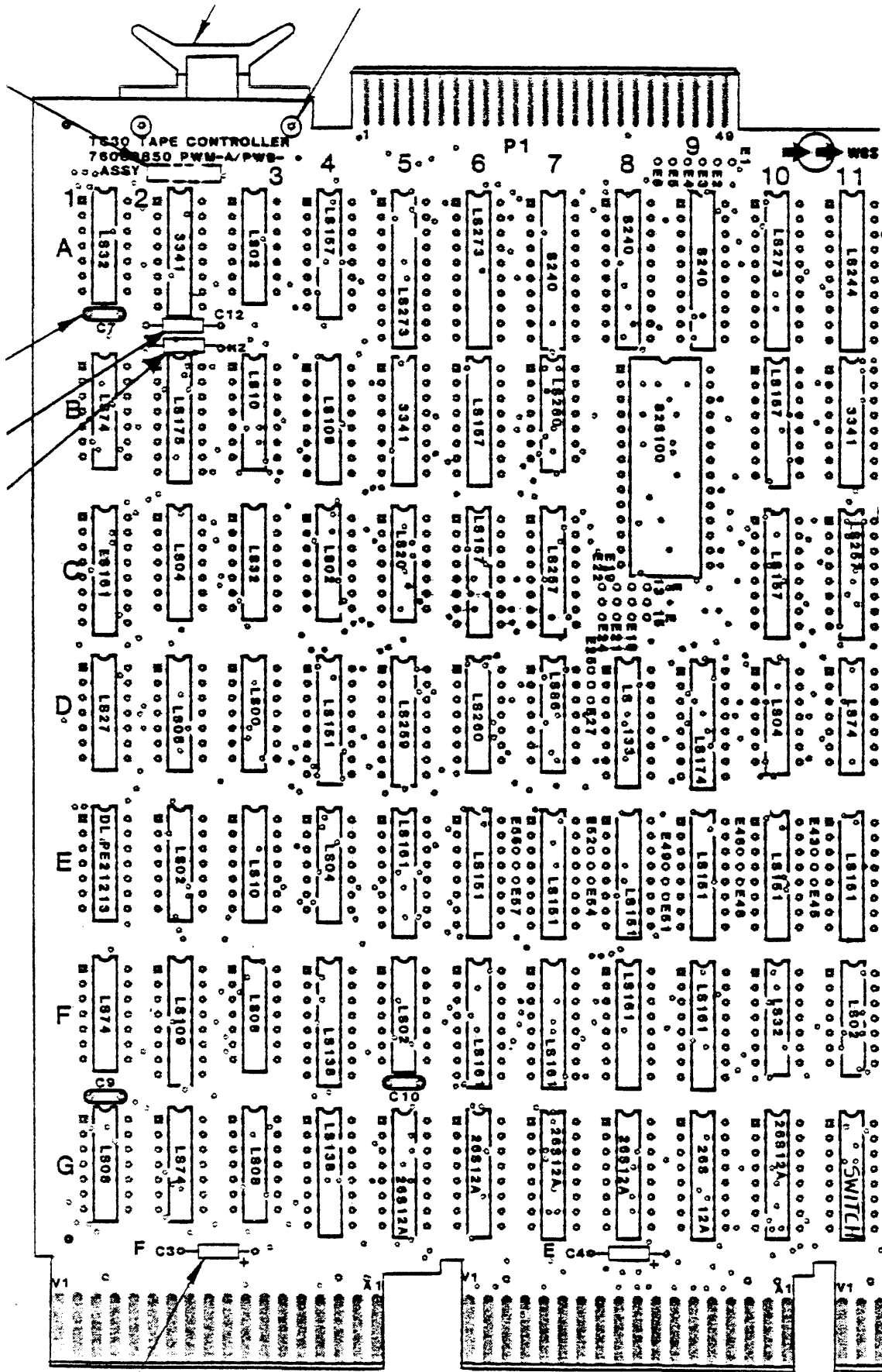

ASSY TC-30 LEFT HALF P60001039

REVISIONS			
LTR	DESCRIPTION	DATE	APPROVED
A	PRODUCTION RELEASE	8/4/83	<i>WJ</i> / <i>BR</i>

LAST DESIGNATION USED		NOT USED
RESISTOR	R5	
CAPACITOR	C43	C6, 17, 21, 25, 30.
DIODE	CR1	
RESISTOR NETWORK	RP4	
E POINTS	E88	E10, 14-17, 21-27, 34-44, 57

SPARE CIRCUITS		
TYPE	LOCATION	PIN NO.
14 PIN PKG.	1A	
LS02	1BA	11, 12, 13
LS02	4C	4, 5, 6, 11, 12, 13
LS32	5C	4, 5, 6
LS11	7C	2, 12, 13
LS32	13C	11, 12, 13
LS04	2E	10, 11
LSDB	1F	11, 12, 13
LS86	1H	1-3, 8-13
LS74	2H	8-13
LS14	3H	8, 9, 12, 13
LS02	5H	11, 12, 13

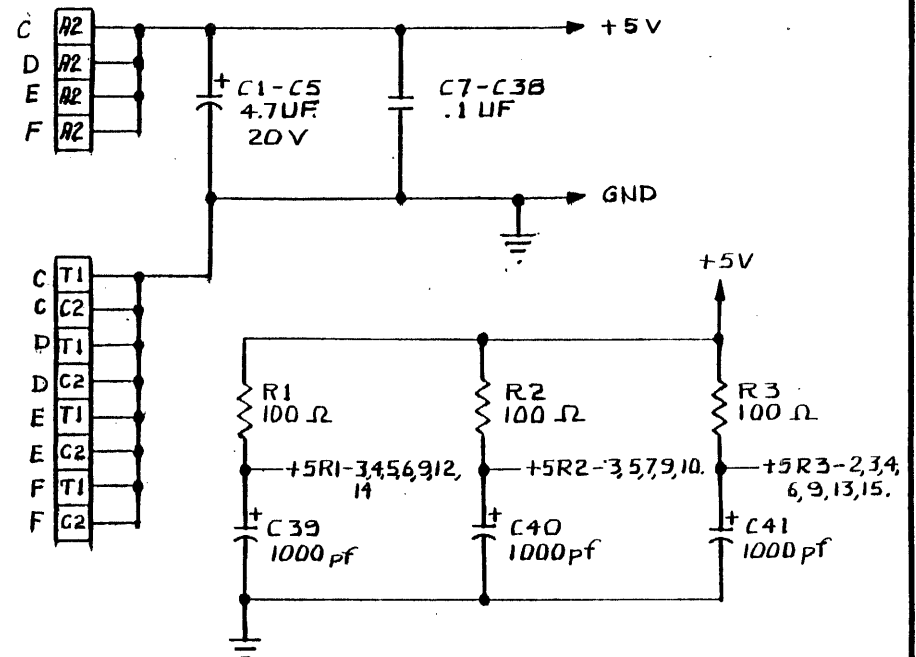

3. REFERENCE ASSY 60001286
 2. ALL CAPACITOR VALUES ARE IN MICROFARADS
 1. ALL RESISTORS VALUES ARE IN OHMS 1/4 W 5%.
 NOTES: UNLESS OTHERWISE SPECIFIED

TOLERANCES UNLESS OTHERWISE SPECIFIED		FRACTIONS DEC ANGLES	
±	±	±	±
APPROVALS		DATE	
DRAWN SIMBECK		1/25/83	
CHECKED <i>WJ</i>		8/3/83	
		8.4.83	
DO NOT SCALE DRAWING		SCALE	SIZE B
		DRAWING NO.	75001107
		SHEET 1 OF 16	



ENGINEERING CHANGE ORDER

SHEET 1 OF 3

CANCELLED BY ECO NO.

ECO# 1222

REV

APPROVAL	CHANGE CHAIRMAN <i>[Signature]</i>	DATE <i>8/25/83</i>	CHANGE TYPE <input type="checkbox"/> DESIGN IMPROVEMENT <input type="checkbox"/> IN-LINE <input checked="" type="checkbox"/> MANDATORY <input type="checkbox"/> RECORD ONLY <input type="checkbox"/> NON-INTERCHANGEABLE <input type="checkbox"/> 1-WAY INTERCHANGEABLE <input type="checkbox"/> 2-WAY INTERCHANGEABLE <input type="checkbox"/> PROD. IMPROV. BULLETIN REQ'D. <input type="checkbox"/> MFG. WORK SHEET ON FILE	DISPOSITION <input type="checkbox"/> NO AFFECT <input type="checkbox"/> USE AS IS <input type="checkbox"/> SCRAP <input checked="" type="checkbox"/> REWORK <input type="checkbox"/> RETROFIT AS REQ'D <input type="checkbox"/> STOP WORK RE-ISSUED BY: DATE:	TITLE TC 30		ECR# 315				
	PRODUCT ENG'R <i>[Signature]</i>				DRAWINGS AFFECTED	OLD REV	NEW REV	DATE INCORP.			
	MFG. <i>AIC</i>	<i>8/25/83</i>			P60001286 B M	A	B				
	Q.C. <i>Karel Kenney</i>	<i>8/25/83</i>			P60001286 ASSY	A	B				
	MKTG. <i>[Signature]</i>	<i>8/25/83</i>			P75001107 SCHE	A	B				
TECH SUPPORT <i>[Signature]</i>	<i>8/25/83</i>	P76001031 PWM	A	TB _D							
		P76001031 PWB	A	TB _D							
ORIGINATOR <i>E FURSE</i>	MGR.	EFFECTIVITY (DATE OR 1ST SERIAL NO.) <i>ALL ASSY. USING "A" REV. P.C.B.'s</i>									
DRAWN BY <i>[Signature]</i>	CHECKED BY <i>Don B.</i>	<i>8/23/83</i>									

REASON FOR CHANGE**SYMPTOM:**

TC 30 DOES NOT PASS THE BUSS GRANT CORRECTLY

PROBLEM:

SIGNAL TO ID-5 IS INCORRECT

SOLUTION:

MAKE CHANGES AS SHOWN ON THIS ECO.

DETAILED DESCRIPTION OF CHANGE TO AFFECTED DOCUMENTS:NOTE: SEE SH. 3 FOR REWORK INSTRUCTIONS1. ASSY P60001286

A.) UPDATE REV. LTR. TO REFLECT CHANGE (REWORK) CAUSED BY SCHEMATIC CHG (SEE SH. 2)

2. B/M P60001286

A.) UPDATE REV. LTR TO REFLECT CHANGES TO ASSY.

B.) ADD ITEM 53 PART NO. P15000565 QTY 1 REF. DES. (LOCATION) C42

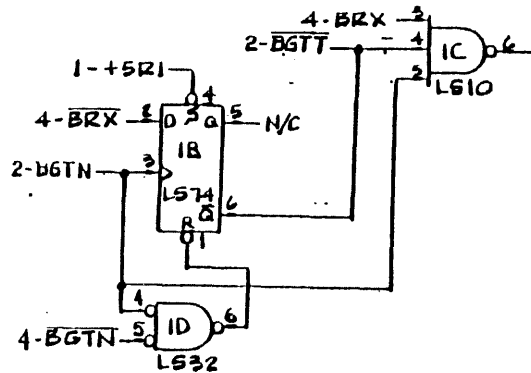
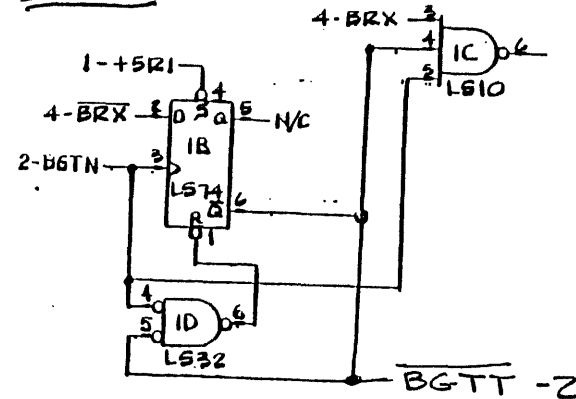
3. SCHEMATIC 75001107
A.) CHANGE SCHE. AS SHOWN BELOW
IS:

S/B:

4. P.W.B. 76001031
A.) UPDATE P.W.B. TO REFLECT CHANGES MADE TO P.W.M.
5. P.W.M. 76001031
A.) UPDATE PWM TO REFLECT CHANGES TO SCHEMATIC



ENGINEERING CHANGE
ORDER

SHEET 3 OF 3

ECO# 1222

REWORK INSTRUCTIONS

6. ON ASSY 60001286 REV A REWORK AS FOLLOWS

A.) LIFT PIN AT 1D5 (LS32)

B.) ADD JUMPER FROM 1D5 (LIFTED PIN) TO 1B6 (I.C. PIN)

C.) UPDATE REV. LTR. OF REWORKED ASSY TO REFLECT NEW REV. LTR.
INDICATED ON THIS ECO (SHT 1)

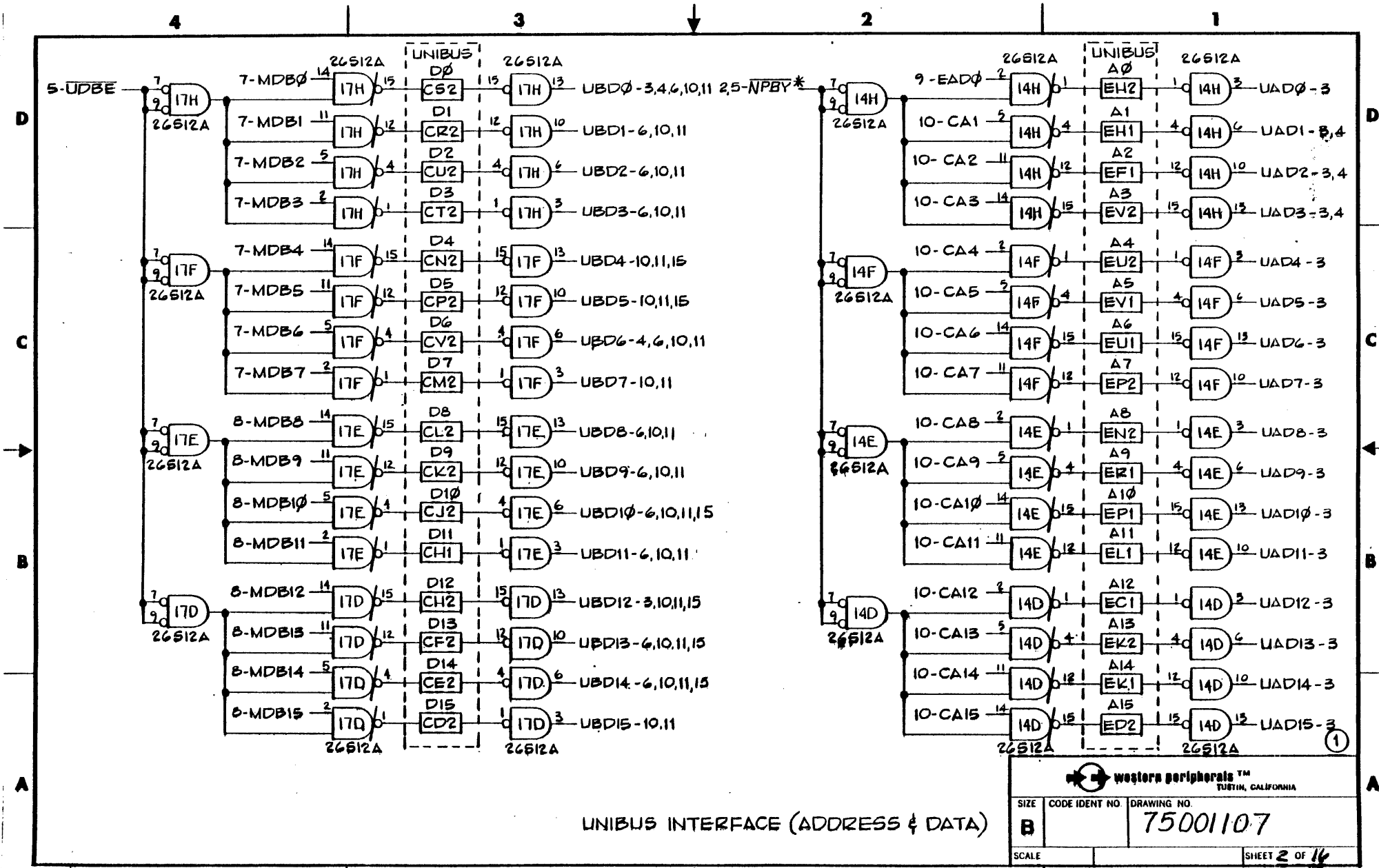

UNIBUS INTERFACE (ADDRESS & DATA)

 western peripherals™ TUSTIN, CALIFORNIA		
SIZE	CODE IDENT NO	DRAWING NO
B		75001107
SCALE	SHEET 2 OF 14	

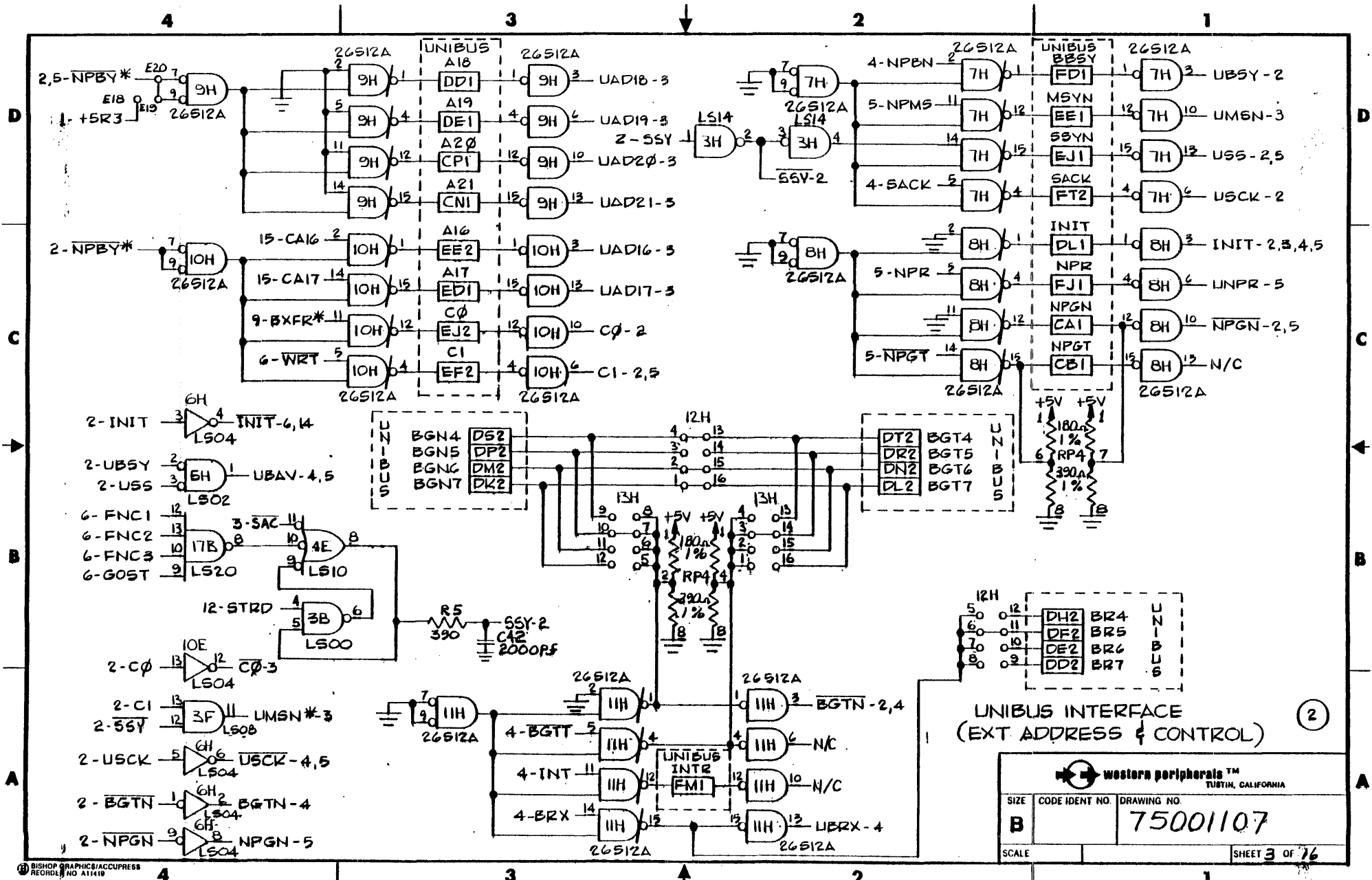

UNIBUS INTERFACE
(EXT ADDRESS & CONTROL)

western peripherals™ TUSTIN, CALIFORNIA		
SIZE	CODE IDENT NO.	DRAWING NO.
B		75001107
SCALE		SHEET 3 OF 76

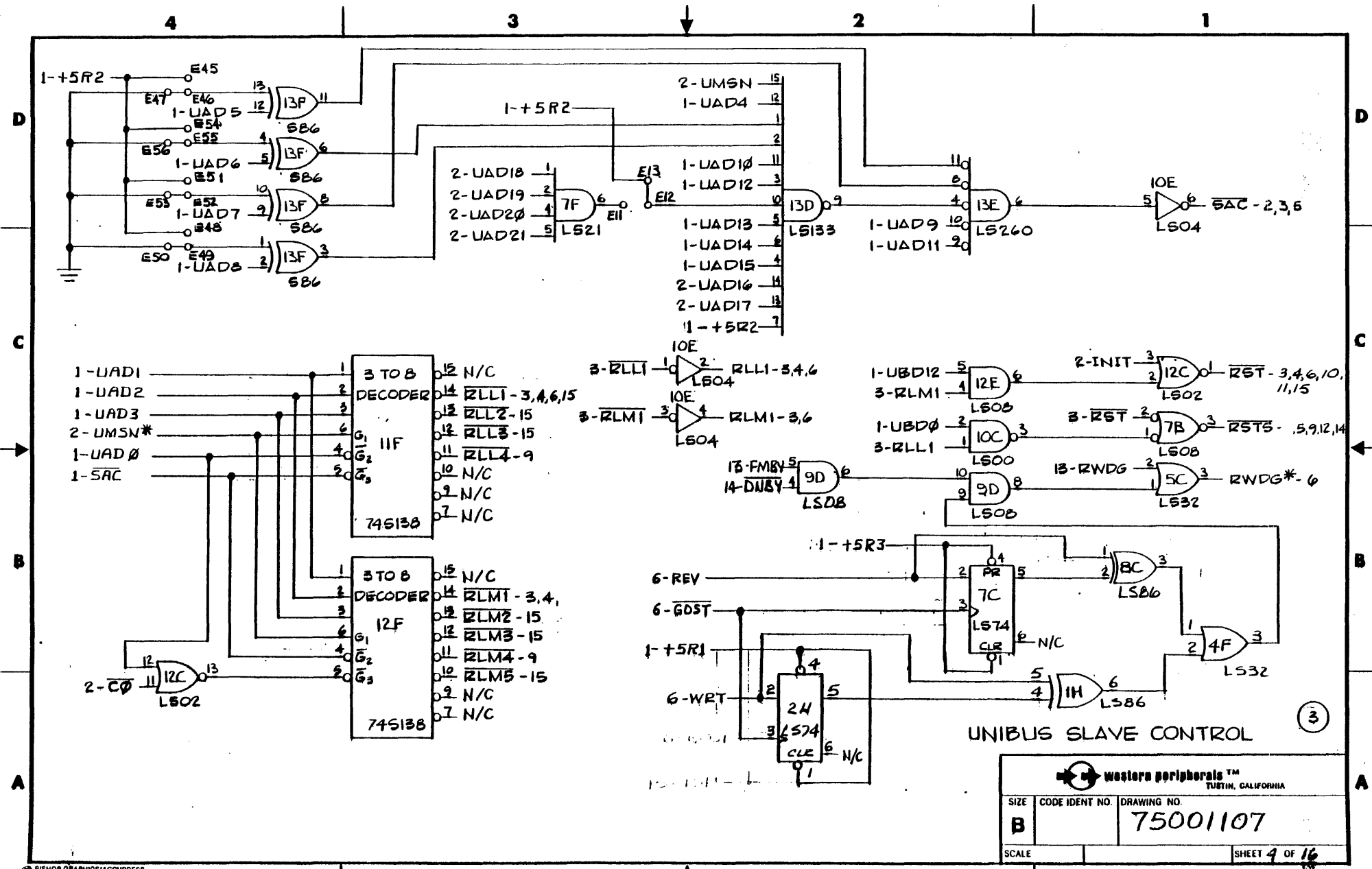

western peripherals™ <small>TUSTIN, CALIFORNIA</small>		
SIZE	CODE IDENT NO.	DRAWING NO.
B		75001107
SCALE		SHEET 4 OF 16

4 3 2 1

D
C
B
A

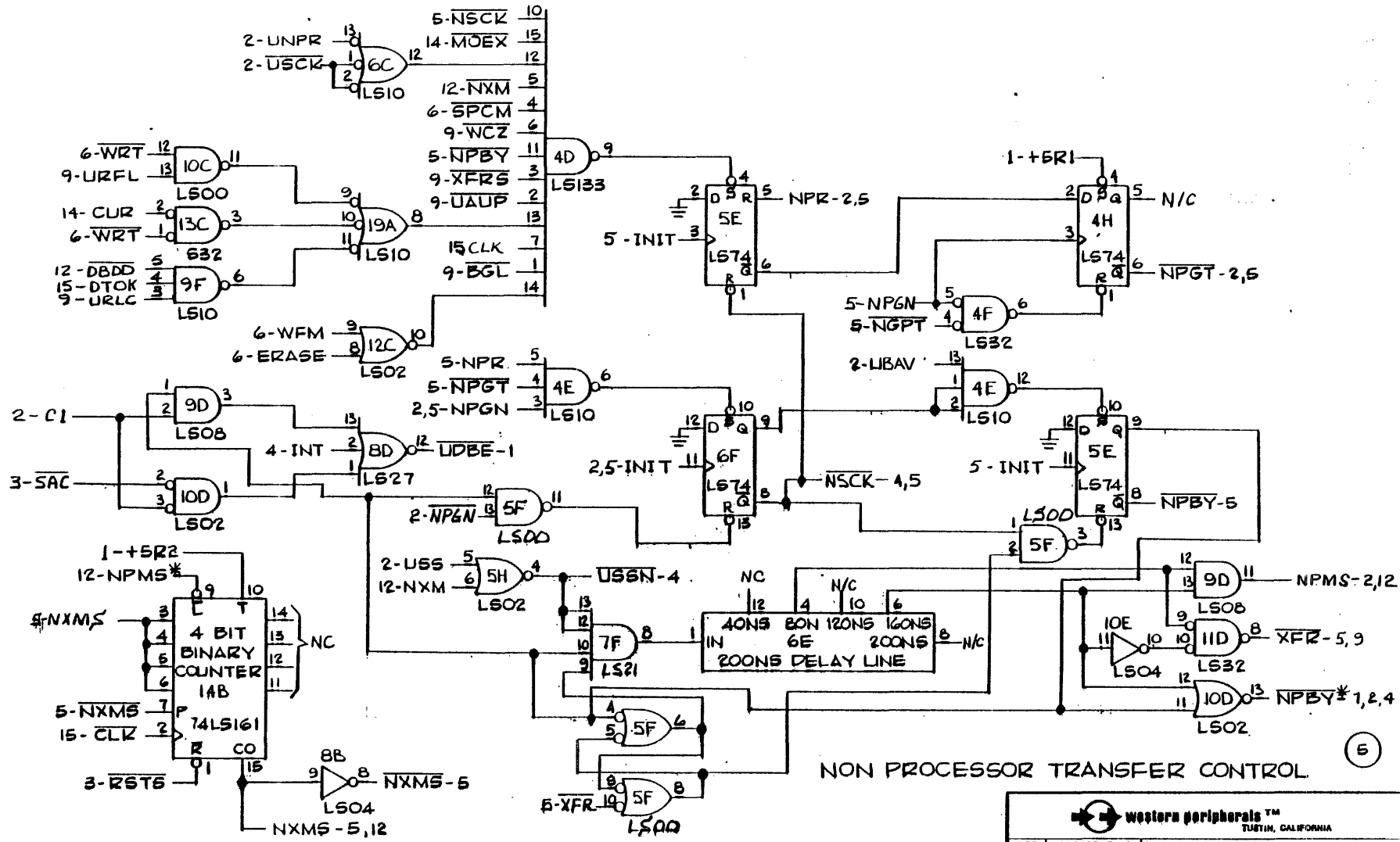

western peripherals™
TUSTIN, CALIFORNIA

SIZE	CODE IDENT NO.	DRAWING NO.
B		75001107
SCALE		SHEET 6 OF 16

4 3 2 1

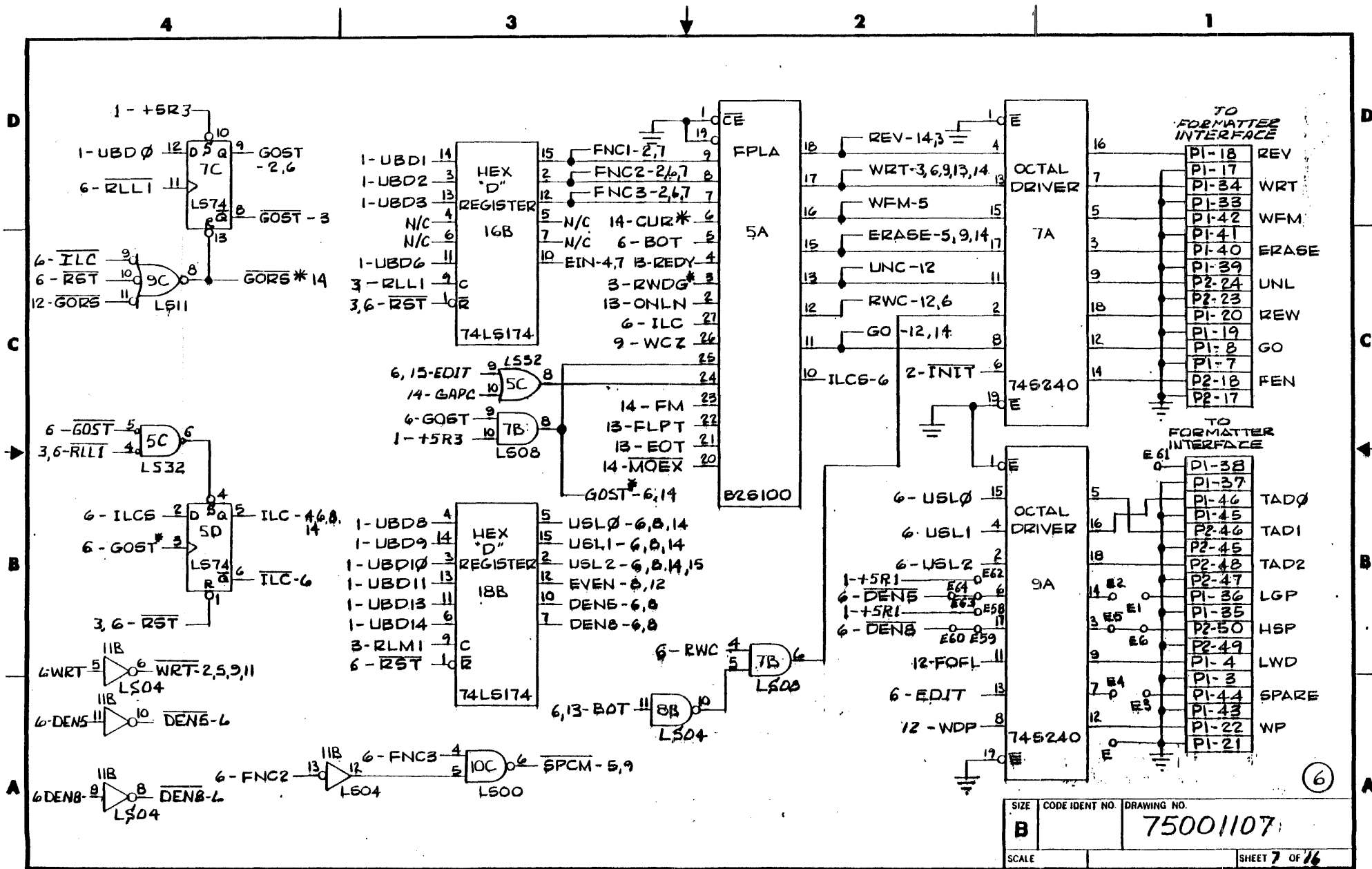

SIZE	CODE IDENT NO.	DRAWING NO.
B		75001107
SCALE	SHEET 7 OF 16	

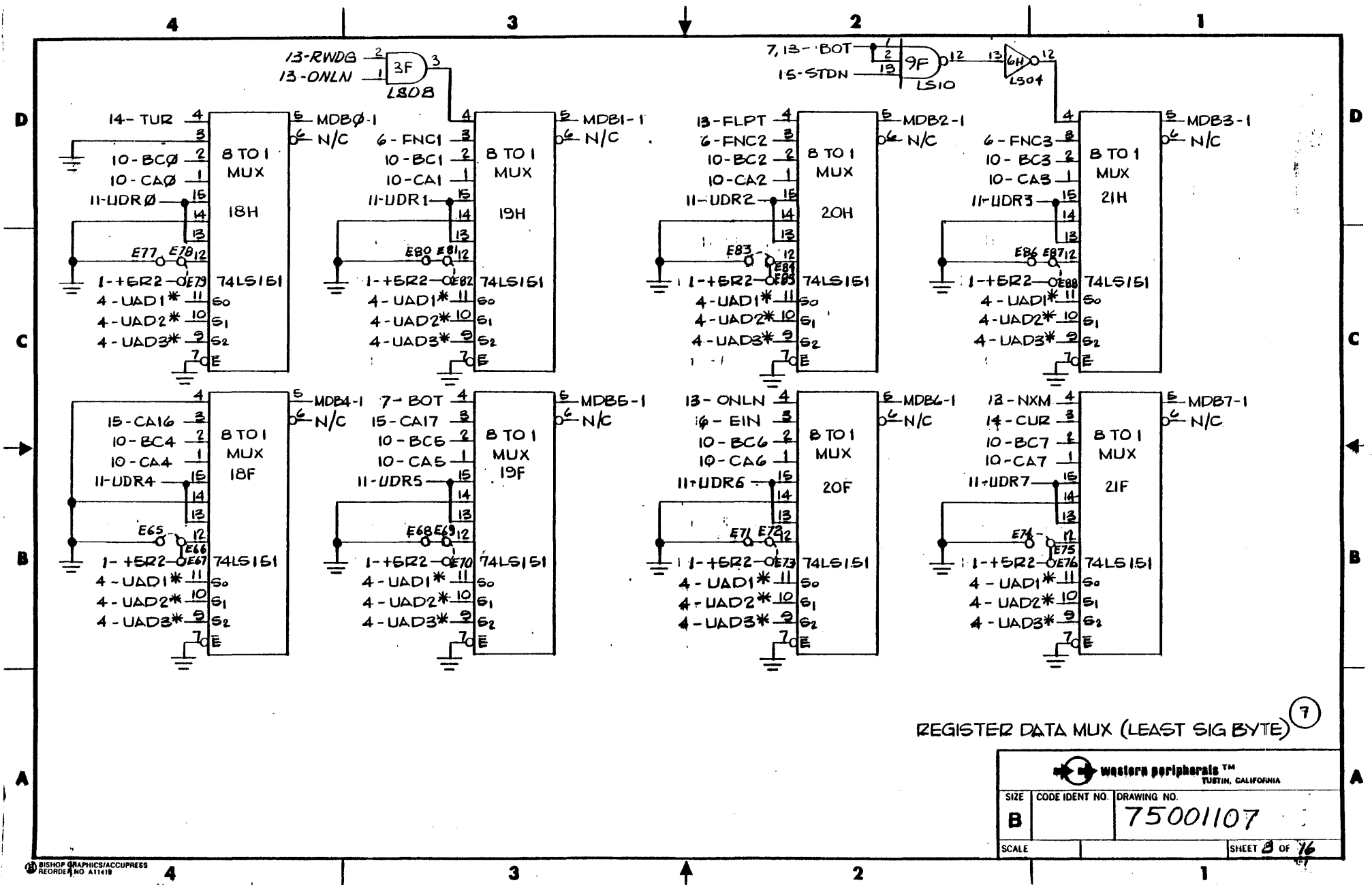

western peripherals™ <small>TUSTIN, CALIFORNIA</small>		
SIZE	CODE IDENT NO.	DRAWING NO.
B		75001107
SCALE		SHEET 3 OF 16

4

3

2

1

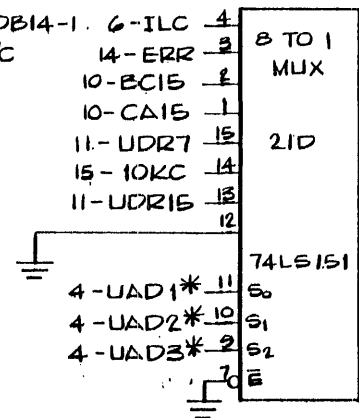
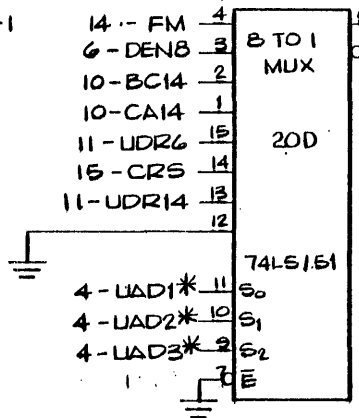
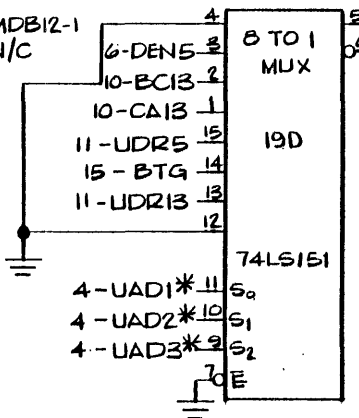
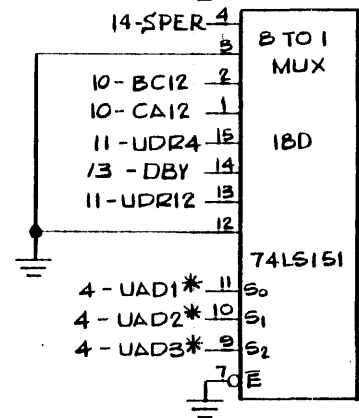
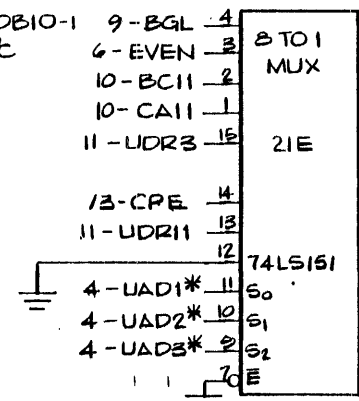
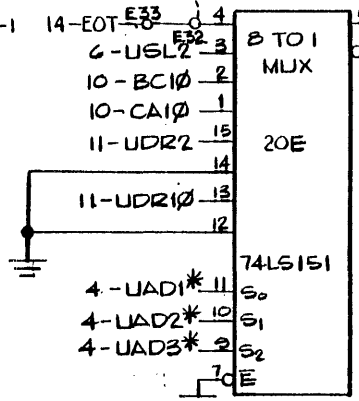
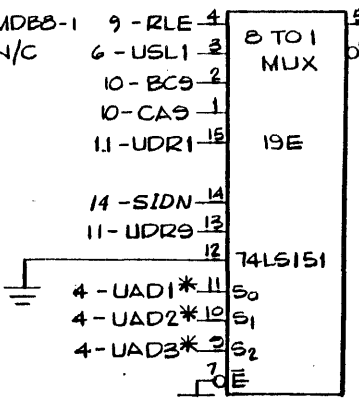
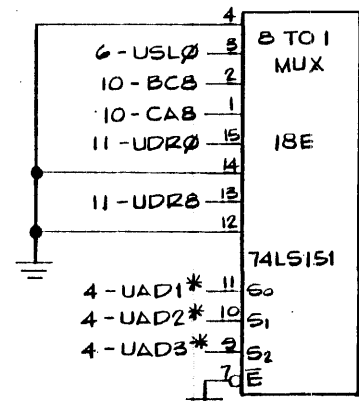

13-FEED

REGISTER DATA MUX (MOST SIG BYTE) 8

western peripherals™ TUSTIN, CALIFORNIA		
SIZE	CODE IDENT NO.	DRAWING NO.
B		75001107
SCALE	SHEET 9 OF 16	

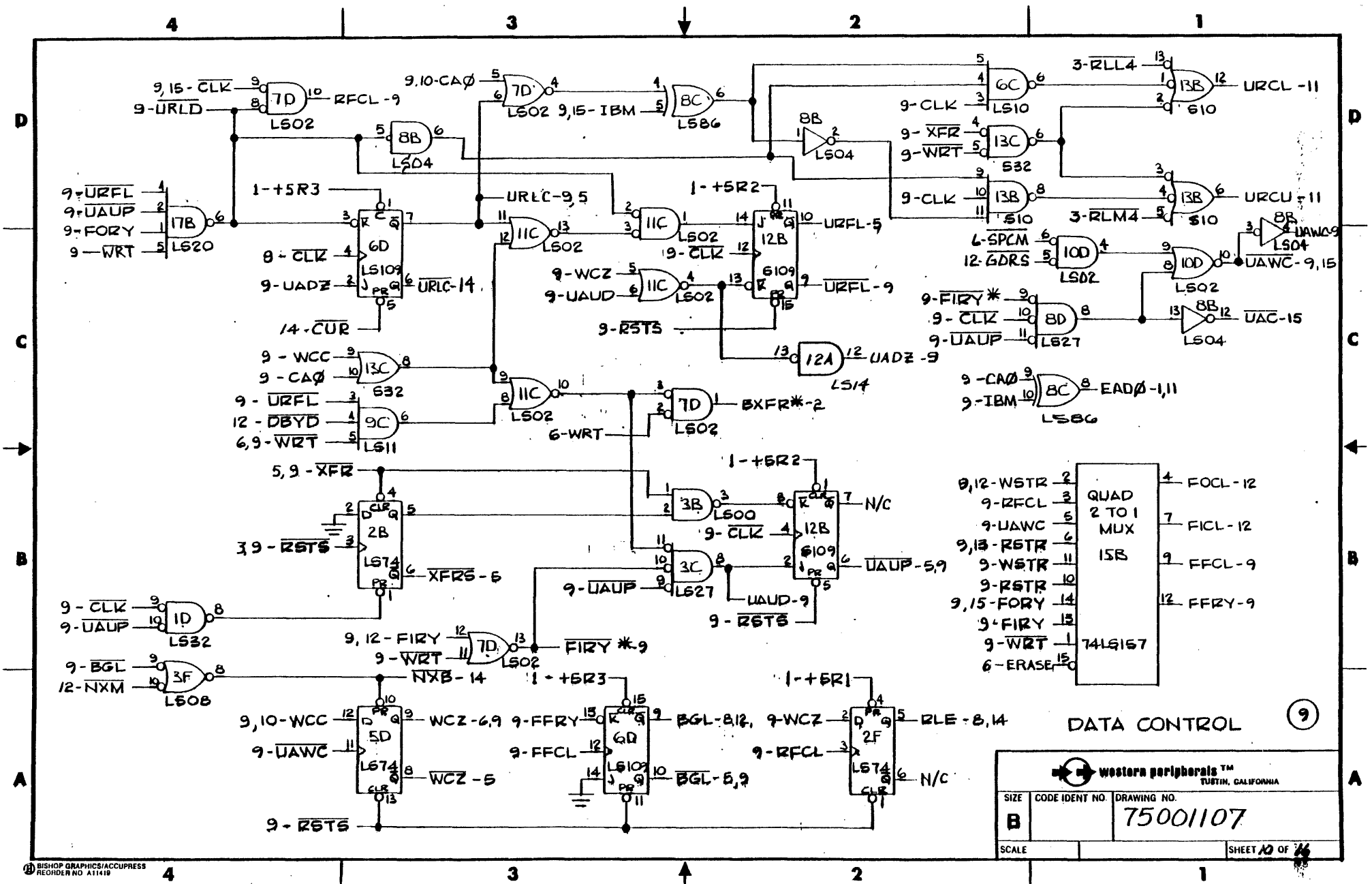

 western peripherals™ <small>TUSTIN, CALIFORNIA</small>		
SIZE	CODE IDENT NO.	DRAWING NO.
B		75001107
SCALE	SHEET 10 OF 16	

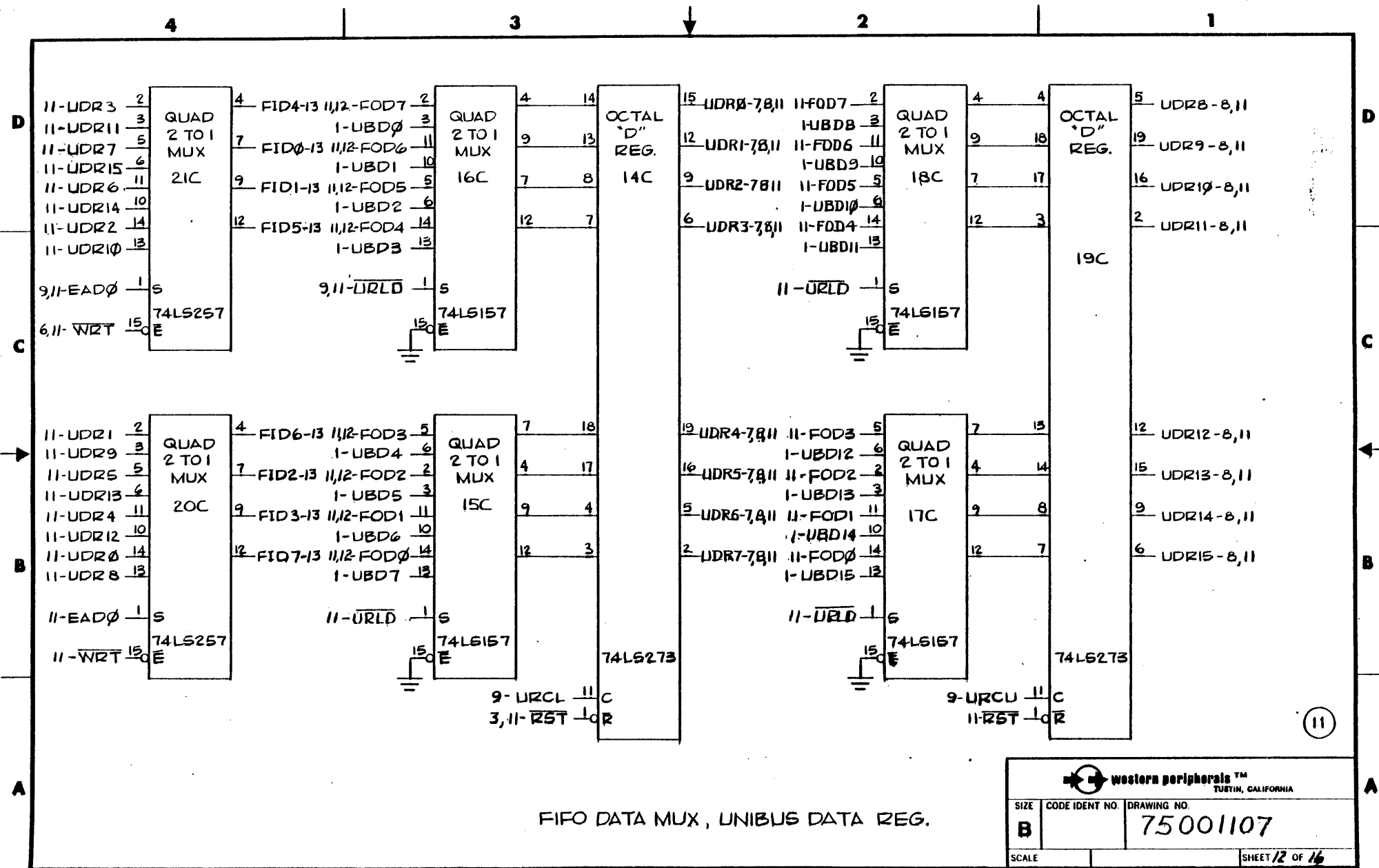

FIFO DATA MUX, UNIBUS DATA REG.

western peripherals™
TUSTIN, CALIFORNIA

SIZE	CODE IDENT NO.	DRAWING NO.
B		75001107
SCALE	SHEET 2 OF 16	

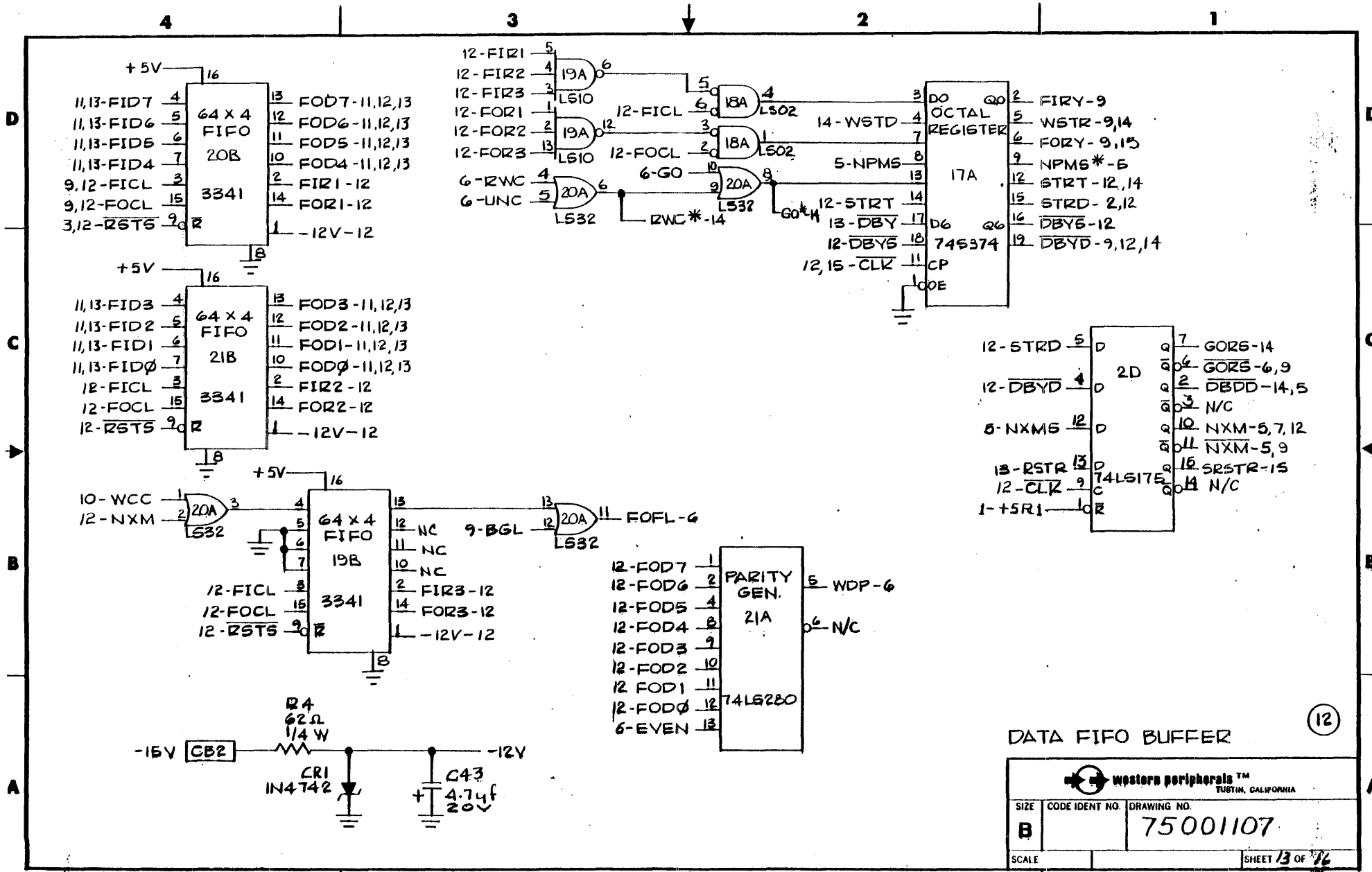

12

DATA FIFO BUFFER

western peripherals™ <small>TUSTIN, CALIFORNIA</small>		
SIZE	CODE IDENT NO.	DRAWING NO.
B		75001107
SCALE	SHEET 13 OF 14	

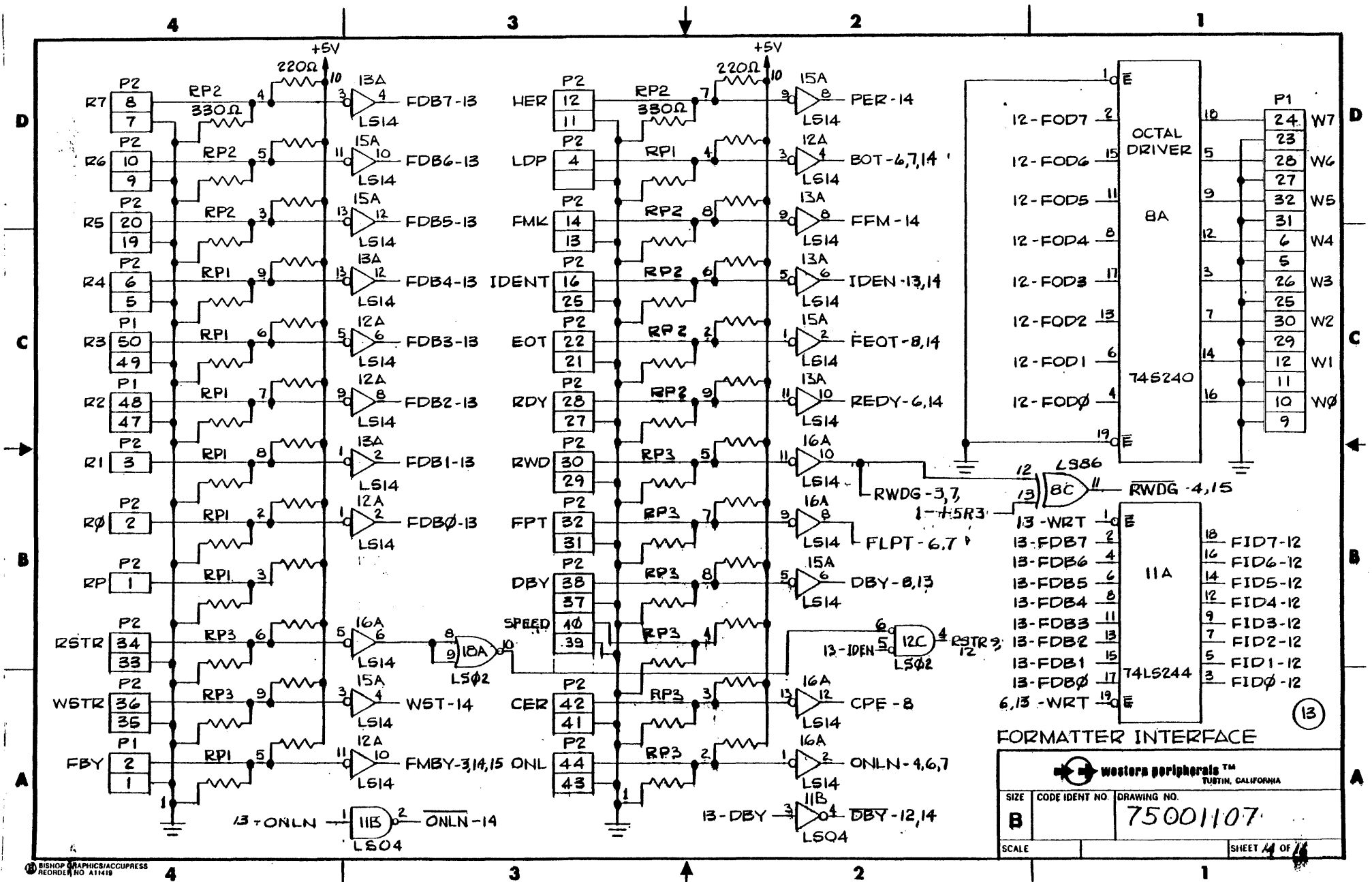

western peripherals™
TUSTIN, CALIFORNIA

SIZE	CODE IDENT NO.	DRAWING NO.
B		75001107
SCALE		SHEET 4 OF 14

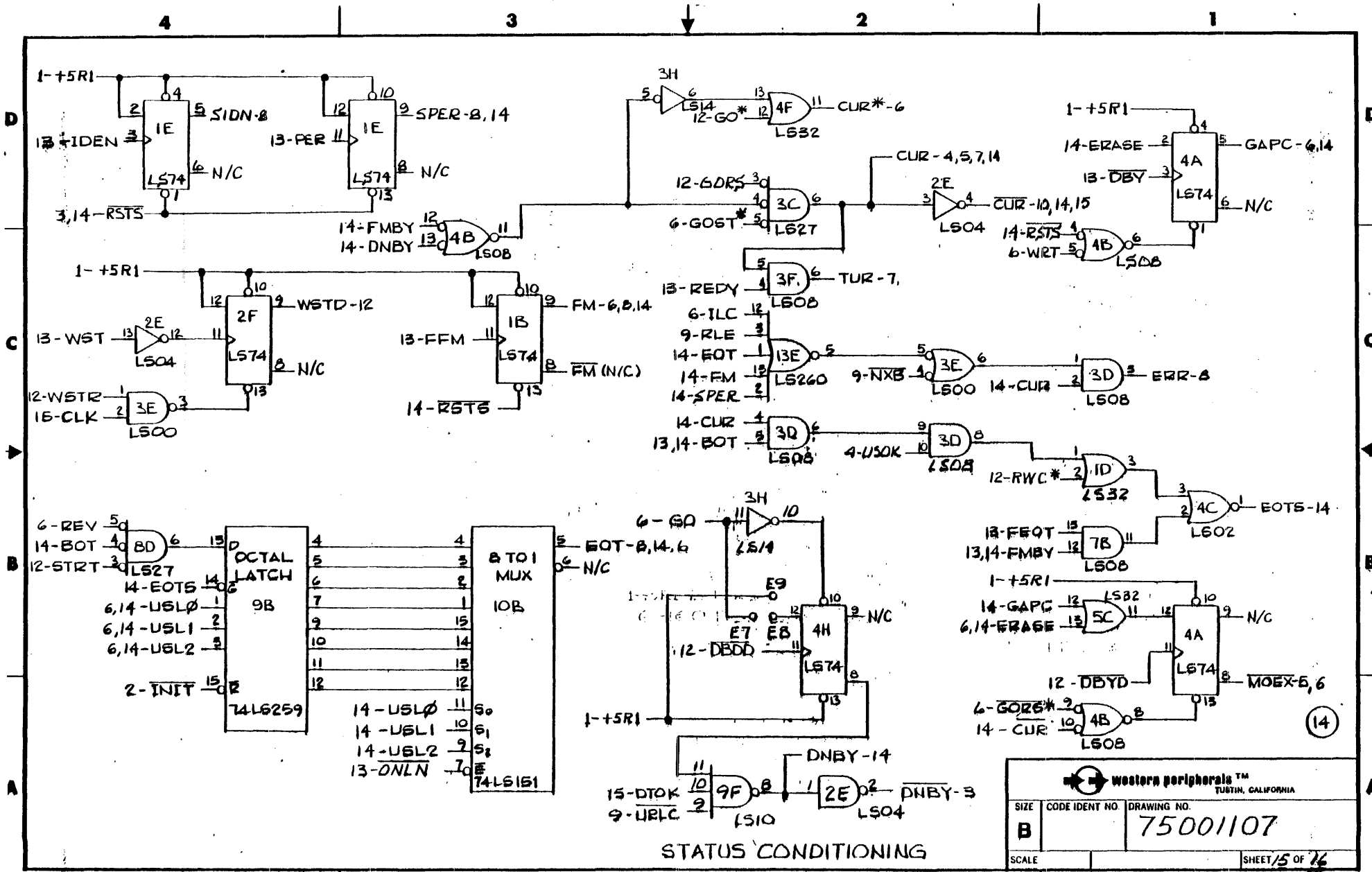

STATUS CONDITIONING

 Western Peripherals™ TUSTIN, CALIFORNIA		
SIZE	CODE IDENT NO.	DRAWING NO.
B		75001107
SCALE		SHEET 5 OF 16

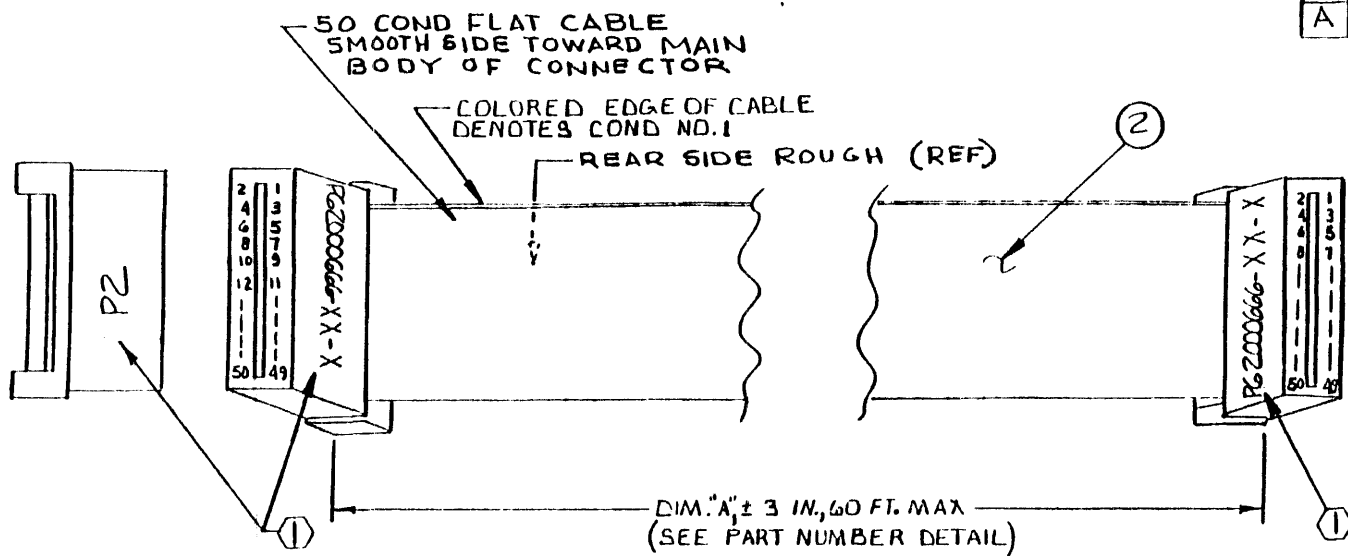

REVISIONS			
LTR	DESCRIPTION	DATE	APPROVED
A	PROD. REL	4-13-82	<i>[Signature]</i>

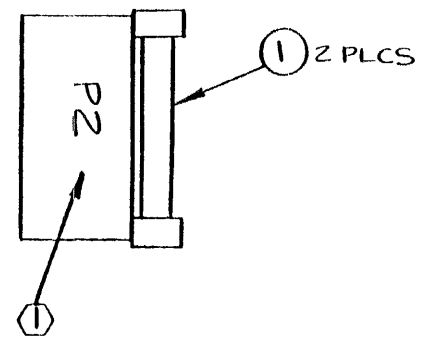

PG2000666-XX-X

BASIC PART NUMBER	_____
DASH NUMBER IN FEET (REF DIM. 'A')	_____
(-07 FOR 7 FT., -10 FOR 10 FT., ETC.)	_____
LATEST REVISION LETTER	_____

- NOTES.
- 1) MARK CHARACTERS SHOWN USING CONTRASTING COLOR INK. SEE PART NUMBER DETAIL FOR MARKING OF VARIABLE CHARACTERS (X's).

2. ASSEMBLY:
 - USE 3M PRESS NO. 3440
 - USE LOCATOR PLATE NO. 3443-11
 - USE SETTING NO 9 OF GAUGE 3436-1
 - CUT CABLE USING SCOTCHFLEX CABLE SHEAR OR EQUIV.
 - SEAT CABLE INTO COVER USING SCOTCHFLEX TOOL NO. 3453, CHECK FOR ALIGNMENT
 - PLACE BODY ON LOCATOR PLATE
 - POSITION COVER AND CABLE OVER CONN BODY
 - LOWER HANDLE TO COMPLETE ASSY
 - REMOVE BY LIFTING ON CONNECTOR

APR 16 1982

FOR PARTS SEE PARTS LIST PG2000666

TOLERANCES UNLESS OTHERWISE SPECIFIED			
FRACTIONS	DEC.		
±	±	±	ASSEMBLY - 'B' CABLE, TC50/TC30
APPROVALS	DATE	SCALE	
DRAWN <i>[Signature]</i>	4-13-82	NONE	
CHECKED <i>[Signature]</i>	4-13-82	SIZE B	
DRAWING NO. PG2000666			SHEET 1 OF 1
DO NOT SCALE DRAWING			

04/14/82 BILL OF MATERIAL TOP LEVEL ASSEMBLY LIST
ASSEMBLY NO. P62000666-1C REVISION A

PAGE 1
DESC: ASSY,B CABLE TC50/TC30

SEQ	PART NUMBER	DESCRIPTION	CON	QTY	HRS	SUB	REV	L	LOCATION	EFF DATE
000	LSC	NO INVENTORY ITEM		2						04/13/82
001	P28005031	CA 28AWG 50 COND 3M 3365/50		10						04/13/82
002	P23000144	CJNN 50CONT FLT CA 3415-0001		2						04/13/82

APR 16 1982

REVISIONS			
LTR	DESCRIPTION	DATE	APPROVED
A	PROD. REL.	4-13-82	<i>W</i>

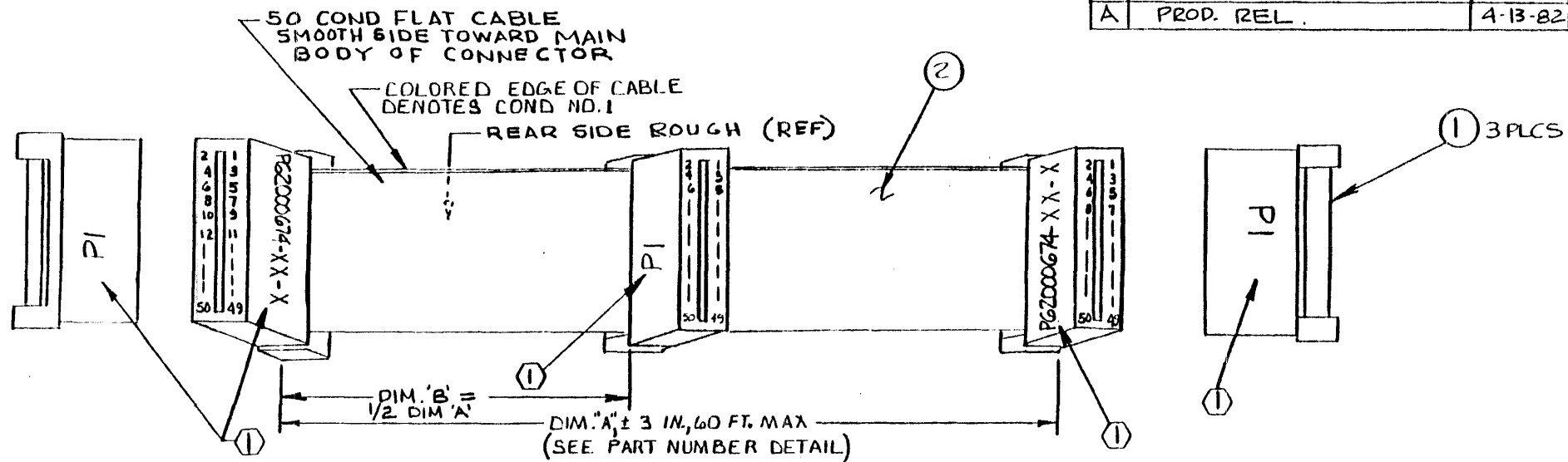

PART NUMBER DETAIL

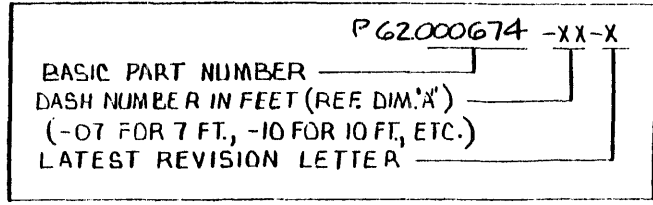

APR 16 1982

FOR PARTS SEE PARTS LIST PG2000674

NOTES.

① MARK CHARACTERS SHOWN USING CONTRASTING COLOR INK.
SEE PART NUMBER DETAIL FOR MARKING OF VARIABLE CHARACTERS (X's).

2. ASSEMBLY:

- USE 3M PRESS NO. 3440
- USE LOCATOR PLATE NO. 3443-II
- USE SETTING NO 9 OF GAUGE 3436-I
- CUT CABLE USING SCOTCHFLEX CABLE SHEAR OR EQUIV.
- SEAT CABLE INTO COVER USING SCOTCHFLEX TOOL NO. 3453, CHECK FOR ALIGNMENT
- PLACE BODY ON LOCATOR PLATE
- POSITION COVER AND CABLE OVER CONN BODY
- LOWER HANDLE TO COMPLETE ASSY
- REMOVE BY LIFTING ON CONNECTOR

TOLERANCES UNLESS OTHERWISE SPECIFIED FRACTIONS DEC. ANGLES		western peripherals	
APPROVALS		DATE	
DRAWN <i>W</i>		4-13-82	
CHECKED <i>W</i>		4-15-82	
SCALE	SIZE	DRAWING NO.	
NONE	B	PG2000674	
DO NOT SCALE DRAWING			SHEET 1 OF 1

04/14/82 BILL OF MATERIAL TOP LEVEL ASSEMBLY LIST
ASSEMBLY NO. P62000674-10 REVISION A

PAGE 1
DESC: ASSY/DAISY CHAIN A CA TC50/3C

SEQ	PART NUMBER	DESCRIPTION	CON	QTY	HRS	SUB	REV	L	LOCATION	EFF DATE
000	LSC	NO INVENTORY ITEM		2	.0					04/13/82
001	P28005031	CA 28AWG 50 COND 3M 3365/50		10	.0					04/13/82
002	P230G0144	CONN 50CONT FLT CA 3415-0001		3	.0					04/13/82

APR 16 1982

REVISIONS			
LTR	DESCRIPTION	DATE	APPROVED
A	PROD. REL.	4-13-82	<i>[Signature]</i>

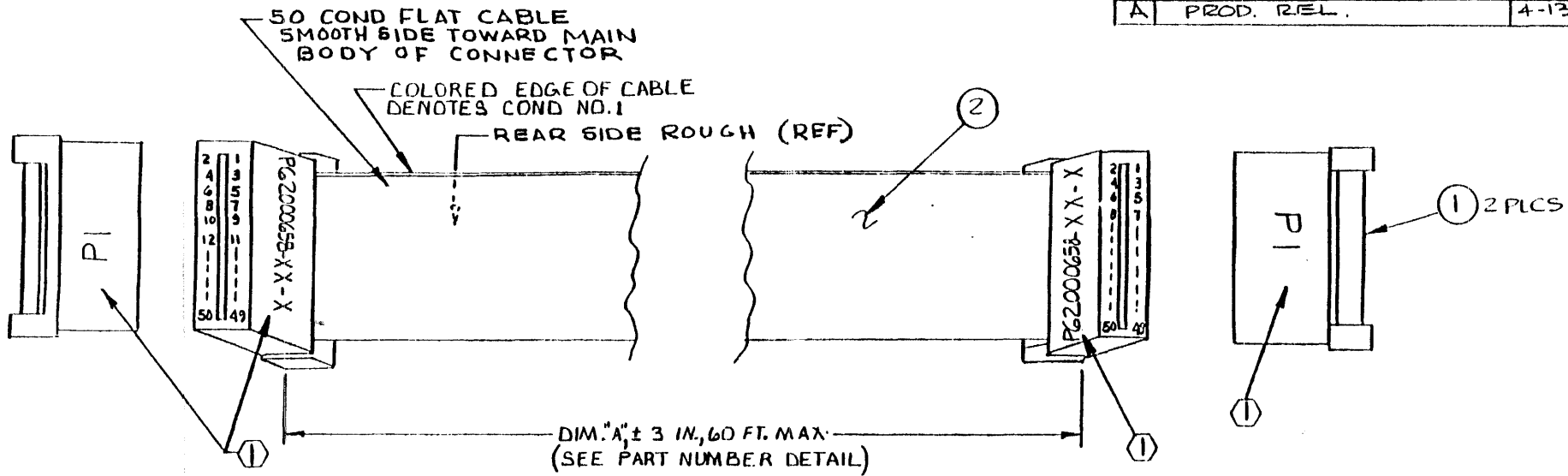

PART NUMBER DETAIL

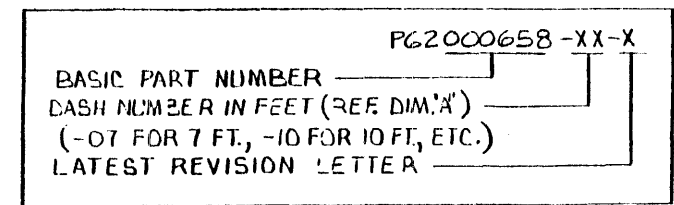

APR 16 1982

FOR PARTS SEE PARTS LIST PG2000658

NOTES.
 (1) MARK CHARACTERS SHOWN USING CONTRASTING COLOR INK.
 SEE PART NUMBER DETAIL FOR MARKING OF VARIABLE CHARACTERS (X's).

2. ASSEMBLY:
- USE 3M PRESS NO. 3440
 - USE LOCATOR PLATE NO. 3443-II
 - USE SETTING NO 9 OF GAUGE 3436-1
 - CUT CABLE USING SCOTCHFLEX CABLE SHEAR OR EQUIV.
 - SEAT CABLE INTO COVER USING SCOTCHFLEX TOOL
 - NO. 3453, CHECK FOR ALIGNMENT
 - PLACE BODY ON LOCATOR PLATE
 - POSITION COVER AND CABLE OVER CONN BODY
 - LOWER HANDLE TO COMPLETE ASSY
 - REMOVE BY LIFTING ON CONNECTOR.

TOLERANCES UNLESS OTHERWISE SPECIFIED FRACTIONS DEC. ANGLES				
±	±			±
APPROVALS	DATE	ASSEMBLY - 'A' CABLE, TC50/TC30		
DRAWN <i>[Signature]</i>	1-13-82			
CHECKED <i>[Signature]</i>	4-13-82			
		SCALE	SIZE	DRAWING NO.
		NONE	B	PG2000658
DO NOT SCALE DRAWING				SHEET 1 OF 1

04/14/82 BILL OF MATERIAL TOP LEVEL ASSEMBLY LIST
ASSEMBLY NO. P62000559-10 REVISION A

PAGE 1
DESC: ASSY, A CABLE TC50/TC30

SEQ	PART NUMBER	DESCRIPTION	CON	QTY	HRS	SUB	REV	L	LOCATION	EFF DATE
000	LSC	NO INVENTORY ITEM		2						04/13/82
001	P28005031	CA 28AWG 50 COND 3M 3365/50		10						04/13/82
002	P23000144	CONN 50CONT FLT CA 3415-0001		2						04/13/82

APR 16 1982

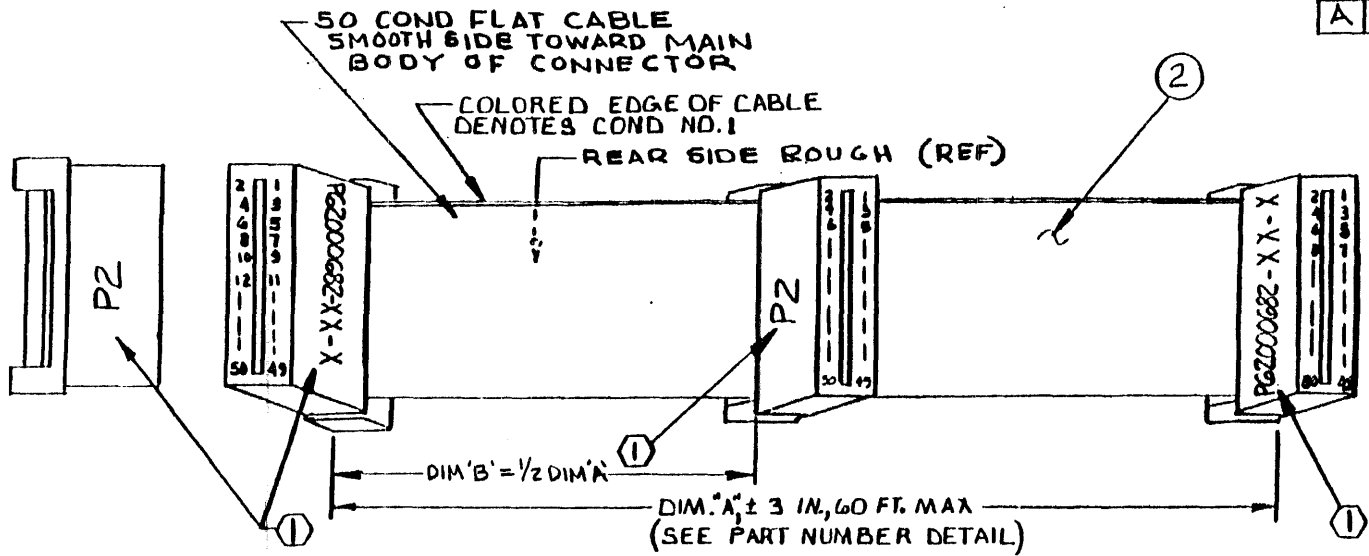

REVISIONS			
LTR	DESCRIPTION	DATE	APPROVED
A	PROD. REL.	4-13-82	<i>M</i>

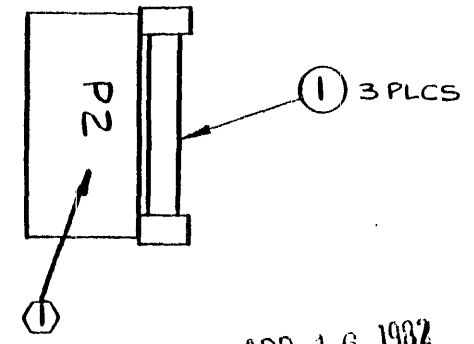

APR 16 1982

PART NUMBER DETAIL

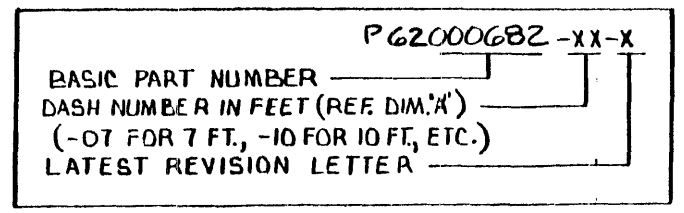

TES.
) MARK CHARACTERS SHOWN USING CONTRASTING COLOR INK.
 SEE PART NUMBER DETAIL FOR MARKING OF VARIABLE CHARACTERS (X's).

- ASSEMBLY:
- USE 3M PRESS NO. 3440
 - USE LOCATOR PLATE NO. 3443-11
 - USE SETTING NO 9 OF GAUGE 3436-1
 - CUT CABLE USING SCOTCHFLEX CABLE SHEAR OR EQUIV.
 - SEAT CABLE INTO COVER USING SCOTCHFLEX TOOL NO. 3453, CHECK FOR ALIGNMENT
 - PLACE BODY ON LOCATOR PLATE
 - POSITION COVER AND CABLE OVER CONN BODY
 - LOWER HANDLE TO COMPLETE ASSY
 - REMOVE BY LIFTING ON CONNECTOR

FOR PARTS SEE PARTS LIST P62000682

TOLERANCES UNLESS OTHERWISE SPECIFIED			
FRACTIONS	DEC.		
±	=	±	
APPROVALS	DATE	ASSY-DAISY CHAIN	
DRAWN <i>[Signature]</i>	4-13-82	'B' CABLE, TC50/TC30	
CHECKED <i>[Signature]</i>	4-15-82	SCALE	SIZE
		NONE	B
		DRAWING NO	
		P62000682	
DO NOT SCALE DRAWING			SHEET 1 OF 1

04/14/82 BILL OF MATERIAL TOP LEVEL ASSEMBLY LIST
ASSEMBLY NO. P62000682-10 REVISION A

PAGE 1
DESC: ASSY,DAISY CHAIN B CA TC50/30

SEQ	PART NUMBER	DESCRIPTION	CON	QTY	HRS	SUB	REV	L	LOCATION	EFF DATE
000	LSC	NO INVENTORY ITEM		2			.0			04/13/82
001	P29005031	CA 28AWG 50 COND 3M 3365/50		10			.0			04/13/82
002	P23000144	CONN SOCONT FLT CA 3415-0001		3			.0			04/13/82

APR 16 1982

