PERTMASTER™

Westminster
 Software

Program written by
Geoffrey Reiss & Robert Fearnley

Produced by
Abtex Software, Ltd.
11 Campus Road
Listerhills Science Park
Bradford BD7 1HR
Great Britain
Phone: (44)-274-734838

Marketed in North America by
Westminster Software Incorporated
600 Hansen Way
Suite 2
Palo Alto
California 94304
Phone: (415) 424-8300
Telex: 759818 WESTMINSTER MP

User's Guide written by
Robert S. Stein

Reference Manual written by
Robert Bradford & Robert S. Stein

©Copyright 1984 by Westminster Software Incorporated

CUSTOMER LICENSE AGREEMENT

This document is a non-exclusive, non-transferable license to use the PertMaster Software (the "Software") and related Documentation (the "Documentation"). It is granted by Abtex Software Ltd. ("Abtex"). It is valid upon your opening and use of the package containing the software; however, no support or assistance will be given until the registration card enclosed with the Software has been signed and returned to Westminster Software Incorporated ("Westminster"), 660 Hansen Way, Suite 2, Palo Alto, California 94304. The license is granted subject to the following terms and conditions.

OWNERSHIP The Software and Documentation are owned and shall remain the property of Abtex, and the ideas and expressions contained therein are proprietary information in which you have no interest and no right to use except as granted by this license.

BACKUP POLICY Abtex (or Westminster, acting as agents for Abtex) will supply a registered user with a backup copy of the Software if required, on payment of a nominal fee for copying, packing and shipping charges.

RESTRICTIONS ON USE AND TRANSFER The original and any backup copies of the Software and Documentation are to be used only in connection with a single computer by the registered user. This condition may be varied in writing by Abtex. You may physically transfer the Software from one computer to another provided that the Software is only used in connection with one computer to another over a network. You may not copy the Software except that you may load the Software into the computer as an essential step to executing the program. You may not copy the Documentation in any manner whatsoever. Neither the Software nor the Documentation may be modified, or translated without prior written permission from Abtex.

NO WARRANTY Abtex does not and cannot guarantee the performance or results that may be obtained by using the Software; accordingly, the Software and Documentation are licensed as is. **NEITHER ABTEX NOR WESTMINSTER MAKES ANY WARRANTY, EITHER EXPRESS OR IMPLIED, AS TO ANY MATTER WHATSOEVER, INCLUDING WITHOUT LIMITATION, ANY WARRANTY OR MERCHANTABILITY OR FITNESS FOR A PARTICULAR PURPOSE.** The whole risk as to the results of the Software is assumed by the user.

LIMITATION OF LIABILITY Neither Abtex, nor Westminster, nor anyone else who has been involved in the preparation, production or distribution of the Software or Documentation shall be liable for direct, incidental or consequential damages including without limitation loss of actual or anticipated profits or benefits, resulting from the use of the Software.

TERM This license is effective until terminated. You may terminate it at any time by destroying all copies of the Software and Documentation in your possession, together with any modifications or merged portions thereof. The license will also terminate if the user fails to comply with any of the terms or conditions of this Agreement. The user agrees to destroy all copies, modifications and merged portions of the Software and Documentation of such termination.

NO OBLIGATION TO PROVIDE ENHANCEMENTS Abtex shall have no obligation hereunder to maintain or improve the Software or Documentation, or to provide you with, or notify you of, any such improvements if developed. However, Abtex may, in its sole discretion, make available to you enhanced versions of the Software and Documentation, which enhanced versions shall be included in the terms "Software" and "Documentation" as the case may be, and shall be subject to the terms and conditions hereof.

GOVERNING LAW This Agreement will be governed by the laws of the State of California.

IBM CORPORATION The following provisions are applicable to copies of this program which run on the IBM personal computer.

"Westminster provides this program and licenses its use in the United States and Puerto Rico. Included in this program are copyrighted materials of the IBM Corporation which are licensed by IBM to you under this Agreement. You assume responsibility for the selection of the program to achieve your intended results, and for the installation, use and results obtained from the program.

LICENSE

You may:

- a. Use the program on a single machine;
- b. copy the program into any machine-readable or printed form for backup or modification purposes in support of your use of a program on the single machine (PertMaster does contain mechanisms to limit copying; such copies are marked "Copy Protected");

- c. modify the program and/or merge it into another program for your use on the single machine (Any portion of this program merged into another program will continue to be subject to the terms and conditions of this Agreement); and,
- d. transfer this program and license to another party if the other party agrees to accept the terms and conditions of this Agreement. If you transfer the program, you must at the same time either transfer all copies whether in printed or machine-readable form to the same party or destroy any copies not transferred; this includes all modifications and portions of the program contained or merged into other programs.

You must reproduce and include the copyright notice on any copy, modification or portion merged into another program.

YOU MAY NOT USE, COPY, MODIFY, OR TRANSFER THE PROGRAM, OR ANY COPY, MODIFICATION OR MERGED PORTION, IN WHOLE OR IN PART, EXCEPT AS EXPRESSLY PROVIDED FOR IN THIS LICENSE.

IF AND WHEN YOU TRANSFER ANY COPY, MODIFICATION, OR MERGED PORTION OF THE PROGRAM TO ANOTHER PARTY, YOUR LICENSE IS AUTOMATICALLY TERMINATED.

You may terminate this license at any time by destroying the program together with all copies, modifications and merged portions in any form. It will also terminate on conditions set forth elsewhere in this Agreement or if you fail to comply with any term or condition of this Agreement. You agree upon such termination to destroy the program, together with all copies, modifications and merged portions in any form.

You agree that you will look only to Westminister, and not to IBM, for any support, maintenance, assistance or the like with respect to this program, and that IBM shall have no liability to you in relation to this program.

You may not sublicense, assign, or transfer the license or the program except as expressly provided in this Agreement. Any attempt otherwise to sublicense, assign or transfer any of the rights, duties, or obligations hereunder is void.

This Agreement will be governed by the laws of the State of Florida.”

COPYRIGHT NOTICE

SOFTWARE Copyright 1982 by Abtex Software Ltd., Great Britain. All rights are reserved. This document may not, in whole or in part, be copied, photocopied, reproduced, translated or reduced to any electronic medium or machine-readable form without prior consent in writing from:

Abtex Software Ltd.
11 Campus Road
Listerhills Science Park
Bradford BD7 1HR
Great Britain

DOCUMENTATION Copyright 1984 by Westminster Software Incorporated, California. All rights are reserved. This document may not, in whole or in part, be copied, photocopied, reproduced, translated or reduced to any electronic medium or machine-readable form without prior consent in writing from:

Westminster Software Incorporated
660 Hansen Way, Suite 2
Palo Alto
California 94304

ACKNOWLEDGEMENTS

CP/M is a trademark of Digital Research, Inc.
dBASE II is a trademark of Ashton-Tate, Inc.
Lotus 1-2-3 is a trademark of Lotus Development Corporation
MS-DOS is a trademark of Microsoft Corporation
PC DOS is a trademark of International Business Machines Corporation
SuperCalc, SuperCalc 2, and SuperCalc 3 are trademarks of Sorcim Corporation

Portions of the software program are copyrighted by Microsoft in 1982.

USER'S GUIDE

PERTMASTER™

Westminster
 Software

| <i>Chapter</i> | <i>Title</i> | <i>Page</i> |
|----------------|--|-------------|
| 1 | INTRODUCTION TO PERTMASTER Introduction - Who Can Use Network Analysis and PERTMASTER? - Computer Hardware Requirements - Technical Support | 1-1 |
| 2 | HOW TO USE THIS MANUAL What To Read - Typefaces Used In This Manual | 1-3 |
| 3 | AN OVERVIEW OF NETWORK ANALYSIS AND PERTMASTER What Is Network Analysis? - Background Informa- tion - PERTMASTER's Network Analysis - Project Requisites - Graphic Networks - References | 1-5 |
| 4 | STARTING PERTMASTER Setting Up Your Computer - PERTMASTER's Disks - Configuring the PERTMASTER Disk to Your Computer - Configuring PERTMASTER to Your Computer | 1-9 |
| 5 | CREATING AN ARROW PLAN Arrow Notation - Simple Relationship Between Activities - Complex Relationships - Dummy Activities - Creating a New Arrow Plan - Correct- ing Your Plan - Getting a Screen Report - Getting Some Printed Reports - Summary | 1-19 |
| 6 | MORE ABOUT ARROW PLANS AND MAKING CHANGES Why Changes Are Made - Help Menu - Changing Activity Durations - Deleting and Adding Activities - Adding Milestones - Adding Starts and Finishes - Changing Plan Headings - Saving or Abandoning Changes - Using Abbreviations - Summary | 1-45 |

| | | |
|----|---|-------|
| 7 | <p>CREATING A PRECEDENCE PLAN</p> <p>Precedence Notation - Simple Relationship Between Activities - Complex Relationships - Creating a New Precedence Plan - Correcting Your Plan - Getting a Screen Report - Getting Some Printed Reports - Summary</p> | 1-55 |
| 8 | <p>MORE ABOUT PRECEDENCE PLANS AND MAKING CHANGES</p> <p>Why Changes Are Made - Help Menu - Changing Durations of Activities and Links - Deleting and Adding Activities and Links - Adding Milestones - Adding Starts and Finishes - Changing Plan Headings - Saving or Abandoning Changes - Using Abbreviations - Summary</p> | 1-83 |
| 9 | <p>RESOURCE TRACKING</p> <p>Resource Tracking Facility - Purpose and Uses of Resource Tracking - Types of Resources - Handling Large Numbers - Using Multiple Resources On One Report - Incorporating Resources In a Plan - Entering and Changing Resources - Getting Reports On Resources</p> | 1-94 |
| 10 | <p>REPORTS</p> <p>Analysis - Getting Reports - Screen Report - Selective Reporting - Printed Reports - Disk Reports - List of Activities & Relationships - Standard Report Listing - Project or Period Barcharts - Complete Resources Report - Histogram for a Resource</p> | 1-102 |
| 11 | <p>HOUSEKEEPING</p> <p>PERTMASTER's Housekeeping Facilities - Calendar Files - Abbreviations Files - Calendars, Abbreviations, and Computer Memory - Merging Plans - Other Housekeeping Facilities</p> | 1-126 |

INTRODUCTION

Welcome to PERTMASTER — a computerized network-analysis program.

Network analysis is a management tool that simplifies planning and scheduling, improves management control and communications, and maximizes profits. Typical applications might include:

- Managing a construction project
- Controlling data processing systems development
- Planning and implementing the introduction of a new product
- Designing and building a production line
- Building an aircraft simulator
- Preparing complex documents such as technical manuals for a missile system
- Moving an office across town

WHO CAN USE NETWORK ANALYSIS AND PERTMASTER?

If you are in a decision-making position, regardless of level, you can benefit from PERTMASTER's network analysis. You do not have to be familiar with formal scheduling methods, although previous experience plus additional experience acquired through the use of network analysis will enable you to optimize PERTMASTER's power. As you use PERTMASTER, you will acquire the experience and knowledge to let you utilize this powerful management tool to its fullest.

Because PERTMASTER is menu-driven — that is, all instructions and choices appear on your computer screen — no knowledge of programming is necessary. If you can press one key at a time on a keyboard, you can use PERTMASTER.

COMPUTER HARDWARE REQUIREMENTS

PERTMASTER requires the following computer hardware to operate:

1. A microcomputer using the CP/M-80 (Ver. 2.0 or later) operating system with 64k bytes of user memory (RAM), or one which uses the MS-DOS or PC DOS operating system with a minimum of 128k of RAM. PERTMASTER is tailored to fit either system.

2. At least one disk drive, although in most cases, PERTMASTER will operate better with two drives. With computers having disk drives with small capacities (less than 250k bytes), two drives are essential.
3. A video terminal. A color terminal may be used, but is not required.
4. A printer capable of printing 132 characters per line. Graphics capability is not necessary.

TECHNICAL SUPPORT

Be sure to complete and mail the user license agreement to Westminster Software, Inc. After your completed license agreement has been received and registered, you have full technical support. Just contact either of the following Software Support Groups for any assistance you may require.

Westminster Software, Inc.
Software Support Group
660 Hansen Way, Suite 2
Palo Alto, California 94304
U.S.A.
Telephone (415)-424-8300
 (800)-321-7298 within California
 (800)-321-7300 within rest of U.S.A.
Telex 759818 WESTMINSTER MP

Abtex Software, Ltd.
Software Support Group
11 Campus Road
Listerhills Science Park
Bradford BD7 1HR
Great Britain
Telephone (44)-274-734838
Telex 51564 FOR ABTEX

Please be prepared to give the serial number of your copy of PERTMASTER, since support is not provided to unregistered users.

WHAT TO READ

The PERTMASTER User's Guide has been written to satisfy two needs. First, we want you to be able learn how to use PERTMASTER with a minimum amount of effort and with the least expenditure of time. Second, we want you to become sufficiently proficient in using PERTMASTER so that you won't need the User's Guide.

If you have never used a computer or an applications program before, that last statement may sound contradictory, or even pretentious. What we really mean is that you will acquire your proficiency gradually until, at some point, you will find that you no longer need the tutorial approach in the User's Guide. Instead, you will be able to use the Reference Manual to find answers to questions which may arise in day-to-day use.

The User's Guide consists of the following chapters, the first of which you have probably read already.

| | |
|------------|---|
| Chapter 1 | Introduction to PERTMASTER |
| Chapter 2 | How to Use this Manual |
| Chapter 3 | An Overview of Network Analysis and PERTMASTER |
| Chapter 4 | Starting PERTMASTER |
| Chapter 5 | Creating an Arrow Plan |
| Chapter 6 | More About Arrow Plans and Making Changes |
| Chapter 7 | Creating a Precedence Plan |
| Chapter 8 | More About Precedence Plans and Making Changes |
| Chapter 9 | Resource Tracking |
| Chapter 10 | Reports |
| Chapter 11 | Housekeeping |

We strongly recommend that you read Chapter 3 if you are unfamiliar with network analysis, and at least scan it if you have had prior experience using PERT, CPM, or any other variation of network analysis.

When you are ready to start using PERTMASTER, Chapter 4 will provide you with the necessary information to make the program run on your computer. From there on, just follow the instructions as to which chapter you should go.

Initially, you will learn how to use PERTMASTER in either Chapters 5 and 6 OR Chapters 7 and 8. This will depend on whether you decide to

use Arrow Plans or Precedence Plans. Then, if you decide to use PERTMASTER's powerful resource tracking facility, you will want to read Chapter 9. On the other hand, if you choose not to use resource tracking, you can skip that chapter.

Finally, the reports which are the ultimate product are explained in Chapter 10. There is no reason not to take a quick look right now at the report formats shown in that chapter. As opposed to a mystery novel, we want you to know the ending. It may help you understand what PERTMASTER does with the data that you enter into your computer.

Chapter 11 covers an assortment of PERTMASTER's features which are colloquially called "Housekeeping." These are things which you have to know, but won't use too often. So we saved them for the end, but will make you aware of many of the features in the other chapters.

TYPEFACES USED IN THIS MANUAL

Throughout both the User's Guide and the Reference Manual, we have tried to be consistent in using type which leaves no doubt in your mind as to what to do.

Instructions, commands, or other descriptive information which appear on your computer terminal are printed in **bold sanserif** type in this manual.

Words, numbers, or other data which you must type are printed in **bold italics**, with the following two exceptions:

- ◀**RETURN**▶ indicates the carriage-return key on your keyboard, which may actually be marked "RETURN," "CR," "ENTER," or designated with a right-angle arrow.
- ◀**ESCAPE**▶ indicates the escape key, which is normally marked "ESC" or "ESCAPE."

WHAT IS NETWORK ANALYSIS?

The management tool that we will henceforth call network analysis is known by several names: PERT (Program Evaluation and Review Technique), CPM (Critical Path Method), CPA (Critical Path Analysis), and Network Analysis.

Network analysis enables us to break down a project into activities, decide how long each one will take, and determine how these activities relate to each other. These relationships are the framework of the project. We can calculate the timing of each element and predict which activities are vital to the success of the project. However, timing calculations in a complex project are lengthy and difficult.

That is where PERTMASTER can help. We need only sketch out the activities in a project, give PERTMASTER the pertinent details, and then let it do the tedious calculations so that it can predict the project timing and the resources needed to complete the project.

BACKGROUND INFORMATION

The two most common forms of network analysis are PERT and CPM. Both were developed in the late 1950s, and both are widely used today throughout the industrial and commercial world.

In its basic form, PERT utilizes "expected time" approximations for activities in a project. ("Expected time" is an average of several weighted time estimates.) PERT does not emphasize the analysis of costs, manpower needs, or similar variables. It is best suited to projects with a high degree of uncertainty, such as complex research and development programs.

On the other hand, CPM uses single time estimates for activity durations. It focuses on the programming strategy that will meet schedule requirements at minimum cost, and considers manpower needs, material and equipment requirements, etc. For these reasons, CPM is particularly useful for engineering, manufacturing, and construction projects.

PERTMASTER'S NETWORK ANALYSIS

Because PERTMASTER addresses cost optimization and both human and material resources, it more closely resembles CPM than it does PERT.

Simply stated, PERTMASTER accepts inputs which define a sequence of activities, their durations, and the resources (labor, equipment, money, etc.) necessary to complete each activity. From this information, PERTMASTER calculates the time relationships within the project, identifies the critical activities and paths, and determines the resources needed to complete the overall project.

All of the information generated by PERTMASTER is made available in a series of reports, some of which can be viewed on the screen of your terminal, and all of which can be printed out on your printer. These reports, in the form of tables, barcharts, graphs, and histograms, will enable you to see, at any point in time, the actual status of the project.

Because PERTMASTER can generate these reports immediately after you enter the data, it can be an invaluable tool for determining the effect of changing certain assumptions in your plan. Using a "what if" scenario becomes easy, as does finding out the result of going into a "crash" program.

PROJECT REQUISITES

The requisites of a project which will benefit from the application of network analysis are as follows.

1. The project can be divided into a number of independent, predictable activities.
2. Activities may start and stop independently of one another.
3. Activities occur in an ordered sequence.
4. Each activity connects directly into one or more successor activities or into a "finish."
5. The duration of each activity can be estimated.
6. The completion of all activities marks the end of the project.

GRAPHIC NETWORKS

A project plan is usually started by drawing a graphic network which shows activities, the duration of each activity, and the relationship among the various activities on the plan. If we position the activities along a calendar time scale, we can determine which activities are critical to the success of the project. However, plotting a network in this manner requires a great deal of work initially, plus more work each time a change is made in any part of the plan. With PERTMASTER, you need only show activities, their relationships, and durations on your plan. PERTMASTER will determine the critical path and appropriate activity dates.

There are two generally accepted techniques used to prepare networks: Activity-on-Arrow (or simply Arrow) and Precedence (sometimes called Activity-on-Node).

In an Arrow Network, an activity is represented by an arrow between two geometric shapes, usually circles, which denote the start and finish of the activity. The arrow has a time duration; the circles, or nodes, do not. The basic Arrow activity looks like this.



In Precedence Networks, the activity is represented by a geometric outline (normally a box) which is linked to the next activity with a line and arrow. In this type of network, the activity within the box has a duration, while the link may or may not. The basic Precedence activity appears thus.

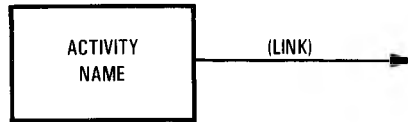

In both types of networks it is normal convention for the start and early activities to be shown at the left, with the work progressing to a finish or to finishes at the right.

In addition to critical paths and activities, network analysis enables you to determine float (also called slack). Float is the amount of time by which a non-critical activity may be delayed from its specified start without affecting the end of a project.

Throughout the rest of this manual, the term "Arrow Plan" will be used to identify a plan which uses the Activity-on-Arrow convention. "Precedence Plan" will denote one which uses a Precedence network. Also, the term "float," instead of slack, will be used exclusively.

If you are just starting to use network analysis, the Arrow format will be easier to learn. Precedence plans are better suited to experienced users. **DON'T TRY TO LEARN BOTH TECHNIQUES AT ONCE!** You will more than likely become confused if you do.

REFERENCES

Dooley, Arch R., "Interpretations of PERT", *Harvard Business Review: Managing Projects & Programs*, President and Fellows of Harvard College, 1971, p. 88.

Dusenbury, Warren, "CPM for New Product Introductions", *Harvard Business Review: Managing Projects & Programs*, President and Fellows of Harvard College, 1971, p. 72.

Lang, Douglas W., *Critical Path Analysis*, Teach Yourself Books (Kent, Great Britain), 1980.

West, Jerome D. and Levy, Ferdinand K., *A Management Guide to PERT/CPM*, Prentice-Hall, Inc., 1977.

West, Jerome D., Levy, Ferdinand K., and Thompson, Gerald L., "The ABCs of the Critical Path Method", *Harvard Business Review: Managing Projects & Programs*, President and Fellows of Harvard College, 1971, p. 61.

SETTING UP YOUR COMPUTER

If you have never used a computer before, you must read the instructions which came with it to be certain that it is operating properly before you can use PERTMASTER. Then be sure to follow all of the steps and tests required to ensure that your printer is interfaced correctly with the computer. If there is evidence of any problem, contact your technical advisor or the dealer from whom you bought your system.

CARE AND HANDLING OF DISKS

PERTMASTER is supplied on flexible magnetic disks commonly called floppy disks. The magnetic material is enclosed in a square cardboard carrier. Although these disks are easily damaged and contaminated, they will last almost indefinitely if you handle them with care and observe the following precautions.

- Never touch the magnetic material through the openings in the carrier. Handle the disk only at the end with the label.
- Do not bend the disk, especially when inserting it in your computer's disk drive.
- Keep the disk away from magnetic fields. In non-technical language, this means keeping the disks at least six inches away from your video terminal, from a television set, from motors, and so on.
- Keep food, drinks, cigarettes, and chemicals away from the disk. Always store the disk in its protective envelope when it is not in use.
- Don't write on the disk label with a sharp pencil or ball-point pen. Always use a felt-tipped pen.
- Don't subject the disk to temperatures lower than 10 degrees Celsius (50 degrees Fahrenheit) or higher than 50 degrees Celsius (122 degrees Fahrenheit). Note that the interior of your car, when parked in the summer sun with all windows closed, can easily exceed the high temperature limit.

PERTMASTER'S DISKS

Although PERTMASTER operates in CP/M-80, MS-DOS, and PC DOS environments, it, like any other program, must be formatted to work with a specific computer. Therefore, it may be supplied on one, two, or three disks. Furthermore, in some cases, a duplicate disk or set of disks may be supplied as working and back-up disk(s). Specific instructions, covering the disks which you will be using, are included in the supplementary instruction sheet enclosed with the disks at the rear of this manual.

If only one copy of each disk is supplied, you must make a back-up copy as a precautionary measure. Instructions for copying disks are in your computer manual.

Store one copy of the program in a safe place. Then, if anything should happen to your working copy, you can either make another copy from the back-up or order another copy from Westminster Software, Inc.

CONFIGURING THE PERTMASTER DISK TO YOUR COMPUTER

These instructions apply only if PERTMASTER has been supplied to on a single disk AND you are using a computer which utilizes two or more floppy-disk drives.

The PERTMASTER disk contains, in addition to the program files, several sample files and an indexing file. These must be copied to a separate disk which will hold your data files. Refer to your computer manual for instructions about copying files. Then copy the following files from the PERTMASTER disk to a blank, formatted disk, which will become your Data Disk:

ABBREV.COD
DAILY.CAL
INDEX
MARKET.0
PRODUCT.0

CONFIGURING PERTMASTER TO YOUR COMPUTER

The first time that you use PERTMASTER, follow the steps listed below. You may want assistance from your technical advisor or the dealer from whom you purchased your computer or PERTMASTER. Be sure to use the working copy of your PERTMASTER disk(s).

1. Turn on your computer and video terminal.

2. Follow the instructions below which apply to the computer system that you are using, then continue with step 3.

- (a) Single Floppy-Disk Drive

Insert the PERTMASTER disk in the drive and close the drive gate. All of your plans and supplementary files will be written to this disk.

- (b) Two or More Floppy-Disk Drives

- (1) If PERTMASTER was supplied to you on one disk, place that disk in drive A and place the Data Disk (which you just made) in another drive of your choice. Your plans and supplementary files will be written to the disk in that drive. Close both drive gates.

- (2) If PERTMASTER was supplied to you on more than one disk, insert the lowest-numbered disk in drive A and place the Data Disk in another drive of your choice. Your plans and supplementary files will be written to the disk in that drive. Close both drive gates.

- (c) One Hard-Disk Drive and One or More Floppy-Disk Drives

Insert the PERTMASTER disk in the floppy-disk drive. (If you have more than one, refer to your computer manual to find out which is the "default" drive.) Close the drive gate and copy PERTMASTER to your hard disk.

NOTE: Even though you have copied PERTMASTER to your hard disk, you must have the PERTMASTER floppy disk in the default drive each time that you want to call up PERTMASTER.

3. When the symbol **A>** (called the A-prompt) appears on your screen, type **CONTROL** and press **◀RETURN▶**. With certain computers, this may not be necessary; the word **CONTROL** may appear automatically.
4. After a few seconds, one of the following notices should be displayed.

```
*****
* *
* *
* *
* *
*****
```

```
< \ \ \ \ \ \ \ \ \ \
  P E R T M A S T E R
  \ \ \ \ \ \ \ \ \ \ >
```

```
*****
* *
* *
* *
* *
*****
```

COPYRIGHT NOTICE

Version 4.6 / 1000

Copyright 1982 By ABTEX Computer Systems Ltd, Aberdeen, Great Britain.

This software and related documentation contains proprietary information and valuable trade secrets of Abtex Computer Systems Ltd. Its receipt or possession does not contain any rights to produce or disclose its contents. Reproduction, disclosure or use without specific written authorization of Abtex Computer Systems Ltd is strictly forbidden.

Your Personal Serial Number is: 91324

PERTMASTER

COPYRIGHT NOTICE

Version 4.6 / 1000

Copyright 1982 By ABTEX Computer Systems Ltd, Aberdeen, Great Britain.

This software and related documentation contains proprietary information and valuable trade secrets of Abtex Computer Systems Ltd. Its receipt or possession does not contain any rights to produce or disclose its contents. Reproduction, disclosure or use without specific written authorization of Abtex Computer Systems Ltd is strictly forbidden.

Your Personal Serial Number is: 91324

NOTE: If this screen or the one which follows is not perfectly formatted, please call one of the Software Support Groups, listed at the end of Chapter 1, for assistance.

5. After a few more seconds, or after you press ◀RETURN▶, PERTMASTER's Main Menu will appear, and should look like one of those shown below and on the next page.

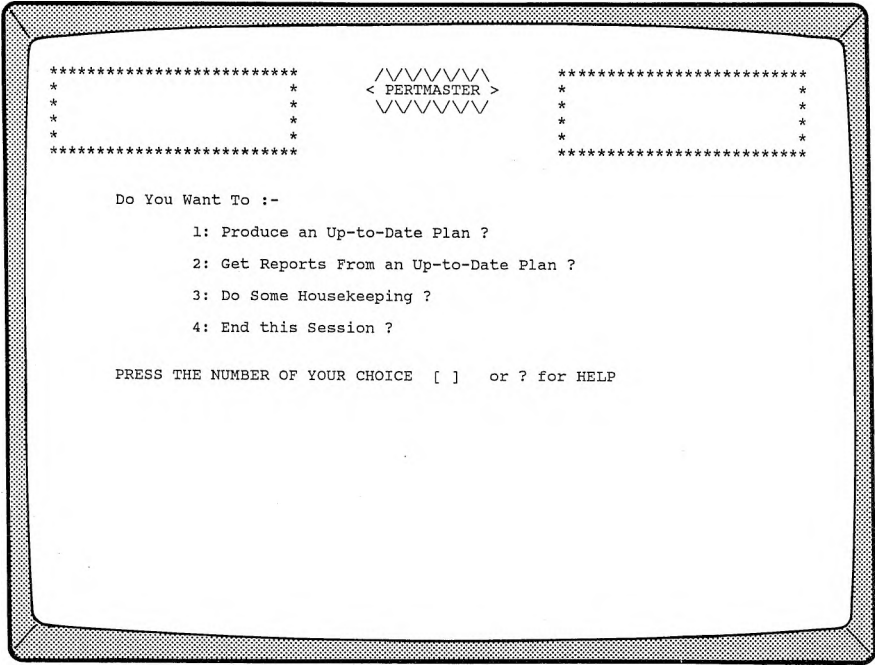

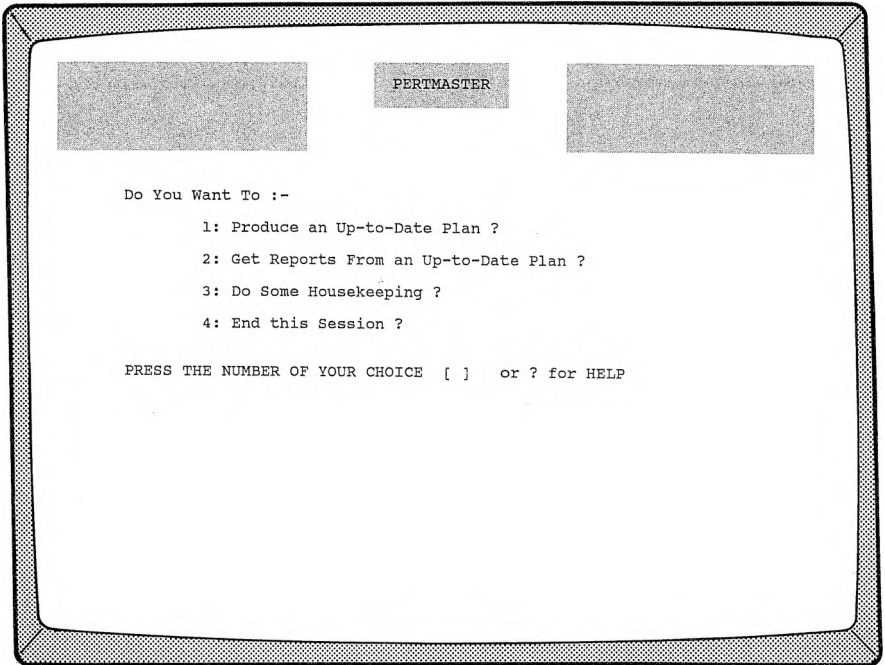

6. You must now provide PERTMASTER with some information about your computer and about your printer. These procedures are covered in the section called Housekeeping, so tell PERTMASTER to **Do Some Housekeeping** by typing 3 to select that choice on the Main Menu. A Housekeeping Menu, similar to the following, will appear.

* *
* *
* *
* *

< PERTMASTER >

* *
* *
* *
* *

Do You Want To :-

- 1: Work with Calendars ?
- 2: Work with Abbreviation Dictionaries ?
- 3: Change Printer Details ?
- 4: Change other System Details ?
- 5: Delete old Plans from a Disk ?
- 6: Copy Plans from One Disk to Another Disk ?
- 7: Merge Plans Together ?
- 8: Do None of These ?

PRESS THE NUMBER OF YOUR CHOICE [] or ? for HELP

- Now type **4**, which will select the option **Change other System Details**. The System Details Menu, similar to the one shown below, will then be displayed.

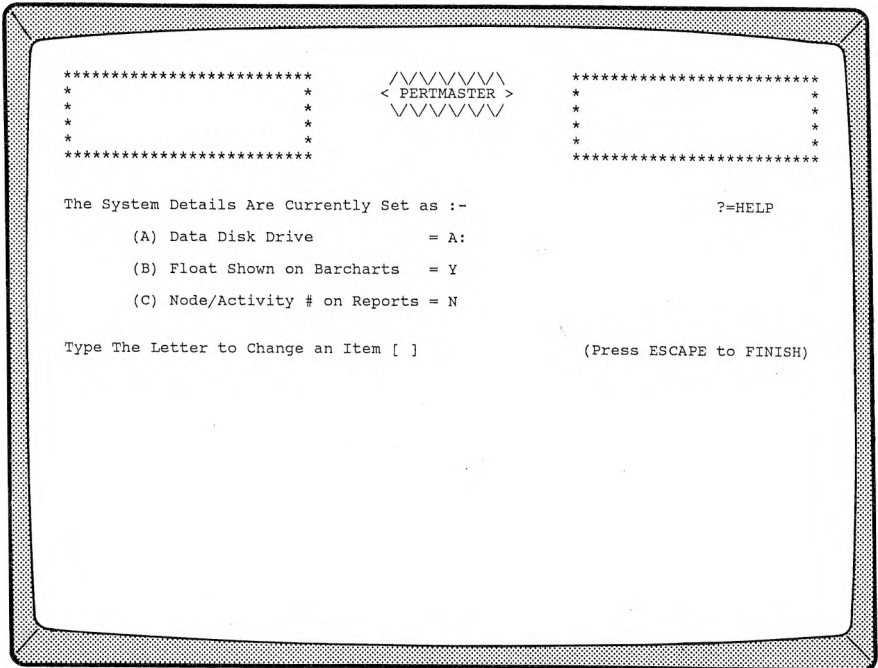

- The **Data Drive Number** must be set to the drive in which your Data Disk will reside. For a system which uses two or more floppy-disk drives, this must be the drive which you selected in step 2. For a hard-disk system, it must be the designation of the hard-disk drive.
To change the data drive, type **A**. The cursor will move to line **(A)**, at which point you should type the appropriate drive designation.
- Float Shown on Barcharts** should be set to **Y** (Yes) at this time. If it is not, type **B**; then type **Y** when the cursor is at line **(B)**.
- Node Activity on Reports** should also be set to **Y**. If it is not, type **C** and then type **Y** when the cursor is at line **(C)**.

11. After completing the above changes, press ◀**ESCAPE**▶, which will return you to the Main Menu.
12. If your printer normally prints 132 characters per line, skip steps 13 and 14, and go directly to step 15. If you are using an 80-column printer which is capable of printing 132 characters per line with a compressed character set, continue with step 13.
13. You must now instruct your 80-column printer to print 132 characters per line. This procedure is also covered in Housekeeping, so again select that choice on the Main Menu by typing 3.
14. When PERTMASTER's Housekeeping Menu reappears, type 3 to let you **Change Printer Details**. Now go to Reference Section 5.3 for instructions on configuring your printer. When you are done, press ◀**ESCAPE**▶ to get back to the Main Menu.
15. Type 4 to **End this Session**. You are now ready to start using PERTMASTER. If you are going to use Arrow Plans, continue with Chapter 5. If you want to use Precedence Plans, go directly to Chapter 7.

ARROW NOTATION

In Chapter 3, we discussed graphic networks and showed that an activity is represented by an arrow between two events which mark the start and finish of the activity.



The activity takes a certain amount of time to complete; this time is called DURATION. The events, or NODES, are only moments in time having no duration.

SIMPLE RELATIONSHIP BETWEEN ACTIVITIES

The network, or PLAN, for a simple relationship involving two activities, would look like this.

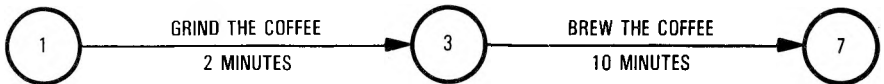

Note that we have given the nodes arbitrary numbers for reference only, and have indicated the estimated duration of each activity. Thus, node 1 indicates that we are about to start grinding the coffee. Node 3 shows that the grinding has been completed, with the succeeding activity ready to start two minutes after we started grinding. Node 7 represents the end of the brewing process, which took ten minutes. Therefore, the entire plan shows that grinding the coffee precedes brewing the coffee, and that both activities require a time span of twelve minutes.

COMPLEX RELATIONSHIPS

A slightly more complex relationship can be shown as follows.

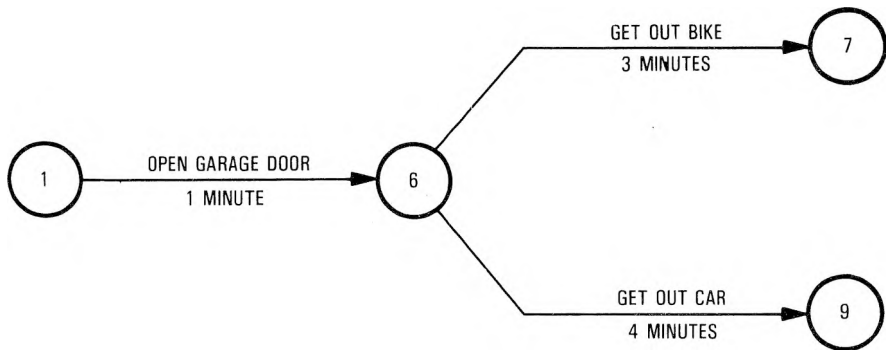

In this case, opening the garage door ends at node 6, and two other activities start at the same node. This means that both getting out the car and getting out the bike can start as soon as node 6 has been reached. Therefore, getting out the car and getting out the bike both succeed opening the garage door. Neither can begin until the garage door has been opened.

The succeeding activities, which we can refer to as “6-7” and “6-9,” are independent of each other. They can go on at the same time, provided that we have a car driver and a bike rider, either of whom could have opened the garage door.

We have also estimated the duration of each activity. So we can see immediately that it will take three minutes to get out the bike, and four minutes to get out the car.

In more complex relationships, like the one shown below, at least one of the paths through the network will take longer than all the others.

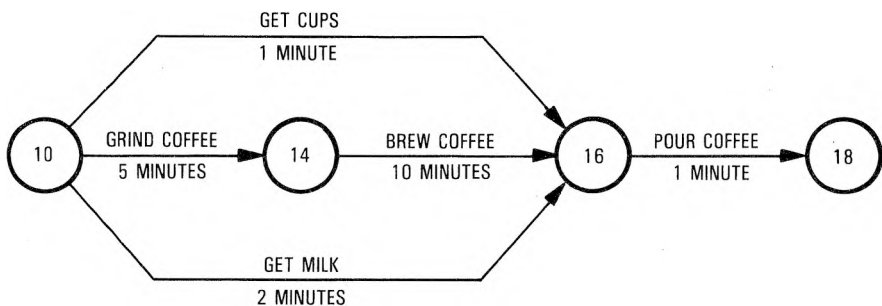

The activities on the longest path must be completed on time if we are to finish the project on time. The longest path is known as the **CRITICAL PATH**. Those activities on the critical path are called **CRITICAL ACTIVITIES**; critical activities are vital to the success of the project.

Other activities — those not on the critical path — can be delayed to some degree without affecting the end date or total time. These activities are said to have **FLOAT**, which is the amount of time that they can be delayed without affecting the end of the project.

In the above plan, grinding the coffee, brewing the coffee, and pouring the coffee are all critical activities, since they are on the critical path. Getting the cups and getting the milk can both be delayed without endangering the schedule. Therefore, both have float.

Large projects can have plans which contain 1000 activities or more. There is a mathematical method of calculating the timing of a plan, but we don't have to concern ourselves about such calculations; **PERTMASTER** does that for us.

DUMMY ACTIVITIES

Arrow plans should normally show only one activity between two nodes so that absolute time calculations can be made between the nodes. Activities which are concurrent, and which start and end at the same nodes as one another, conventionally use an activity called a **DUMMY**. This is simply a logical connector, having no time duration, which precludes more than one activity between two nodes.

The preceding plan shows that both getting the milk and getting the cups start at node 10 and end at node 16. To eliminate this, we can redraw the plan as follows.

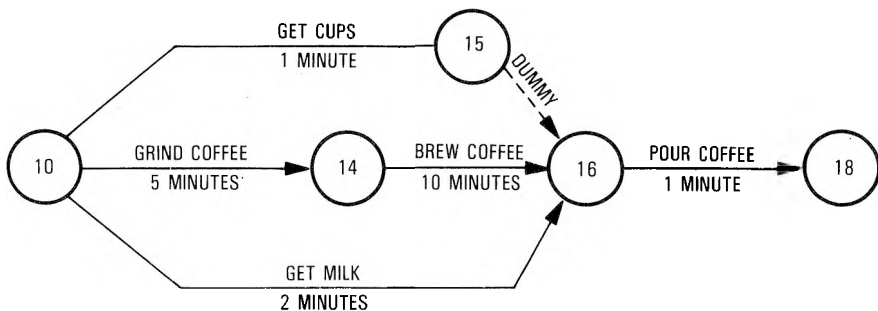

Node 15 has been added to provide a dummy for one of the paths between nodes 10 and 16. Thus, getting the milk is the only activity directly connecting those two nodes. Even though getting the cups is done concurrently, the path on the plan no longer duplicates that of getting the milk.

CREATING A NEW ARROW PLAN

The Plan on Paper

You are now ready to start learning how to use PERTMASTER. The best way to start is to create a brand new plan.

We are going to use the following plan, which covers the launch of a new product. It shows the activities necessary to get the product onto the market, once the product has been designed and tested.

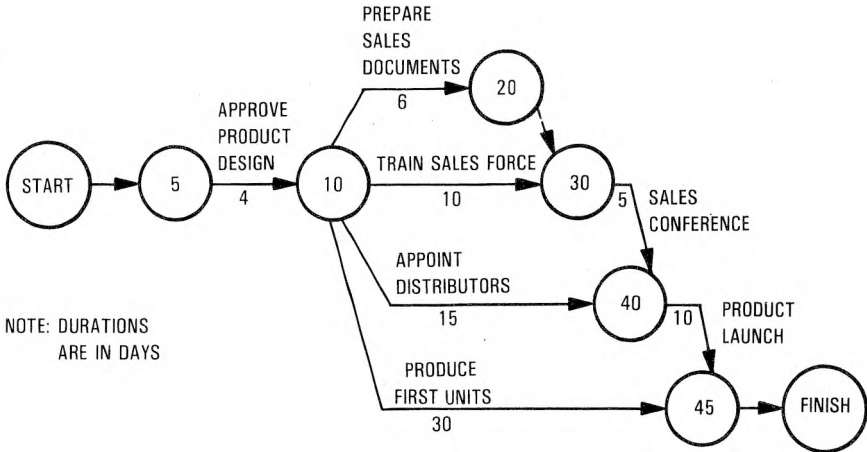

The plan starts at node 5 with activity 5-10, approval of product design. When the product has been approved, an activity which takes four days, node 10 is reached. Now four activities can begin simultaneously.

Activity 10-20, preparing sales documents, takes 6 days. Activity 10-30, training sales force, takes 10 days. Activity 10-40, appointing distributors, takes 15 days. Note that a dummy links the end of the preparation of sales documents (node 20) to node 30. If a dummy were not used, nodes 10 and 30 would be joined by two activities, preparing sales documents and training the sales force, which have different durations. Both of these activities must finished before the sales conference can start.

Meanwhile, the appointment of distributors is going on. This must be completed by the time the sales conference ends, so that the product can be launched.

While all of this is happening, we must produce the first units, which we estimate will take 30 days, and which can begin as soon as the product is approved. The first units must be ready by the completion of the product launch, activity 40-45. The end of the plan is reached at node 45, which is the finish of the project.

You are now ready to call up PERTMASTER and enter the data for your plan.

Calling Up PERTMASTER

Be sure to use the working copy of your PERTMASTER disk(s). Then proceed as follows:

1. Turn on your computer and video terminal.
2. Follow the instructions below which apply to the computer system which you are using, then continue with step 3.
 - (a) Single Floppy-Disk Drive
Insert the PERTMASTER disk in the drive and close the drive gate.
 - (b) Two or More Floppy-Disk Drives
 - (1) If PERTMASTER was supplied to you on one disk, place that disk in drive A and place your Data Disk in the drive which was designated the data drive in Chapter 4. Close both drive gates.
 - (2) If PERTMASTER was supplied to you on more than one disk, insert the lowest-numbered disk in drive A and place the Data Disk in the drive which was designated the data drive in Chapter 4. Close both drive gates.
 - (c) One Hard-Disk Drive and One or More Floppy-Disk Drives
Insert the PERTMASTER disk in the floppy-disk drive. (If you have more than one drive, refer to your computer manual to find out which is the "default" drive.) Close the drive gate.

NOTE: You must have the PERTMASTER floppy disk in the default drive each time that you want to call up PERTMASTER.

3. When the A-prompt (A>) appears on your screen, type **CONTROL** and press ◀RETURN▶. With certain computers, this may not be necessary; the word **CONTROL** may appear automatically.
4. After a few seconds, the Copyright Notice should be displayed. A seconds later, or after you press RETURN, PERTMASTER's Main Menu will appear, and should look something like this.

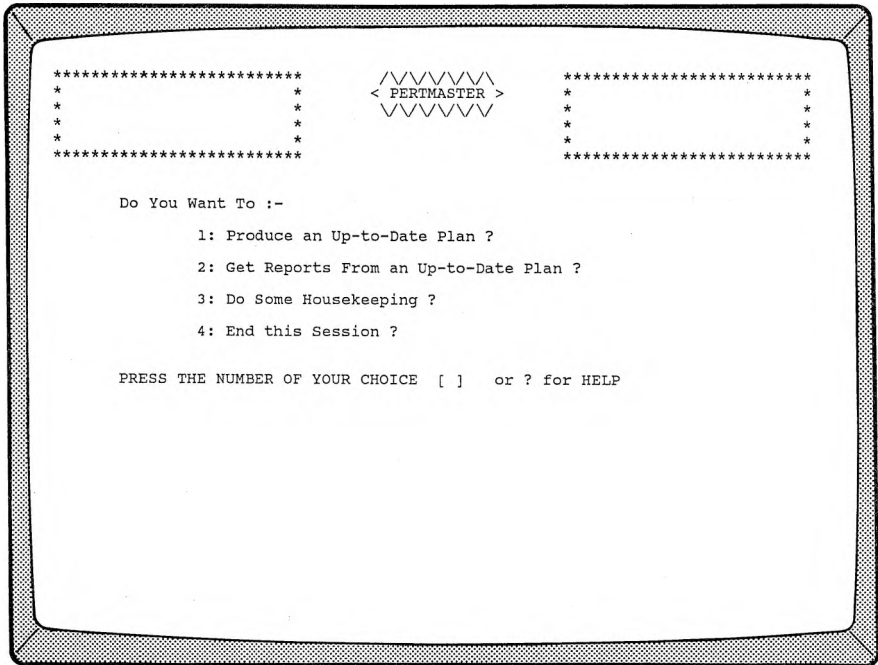

The exact appearance of PERTMASTER's displays will depend on the computer which you are using. However, the wording on the screen will always be the same.

In virtually all of PERTMASTER's menus and screen displays, you will see either

? for HELP

or

? = HELP

This indicates that you can get help on your entries or on what you want PERTMASTER to do simply by typing a question mark any time either of these two statements is on the screen.

Entering the Plan Identification in PERTMASTER

Now that you have a plan on paper, and PERTMASTER is up and running, you can enter the necessary data to allow the program to calculate the results and print out reports. In doing so, you will find out that PERTMASTER requires you to have a calendar and a list of abbreviations before you can get any reports from your plan.

To make it easier to start, we have included a calendar and a list of abbreviations on your program disk(s). These are in two files on the disk. (A file is related information stored as a single group with a unique name.) The calendar file is named DAILY.CAL and the abbreviations file is named ABBREV.COD. You need only remember the first part of each name, that is, DAILY for the calendar file and ABBREV for the abbreviations file. (The portion to the right of the period is called an extension, and allows PERTMASTER to identify the type of file.)

Your computer screen should still show PERTMASTER's Main Menu. Since you want to create a new plan, type *I* to **Produce an Up-to-Date Plan**. After a short delay, the menu shown on the next page will appear.

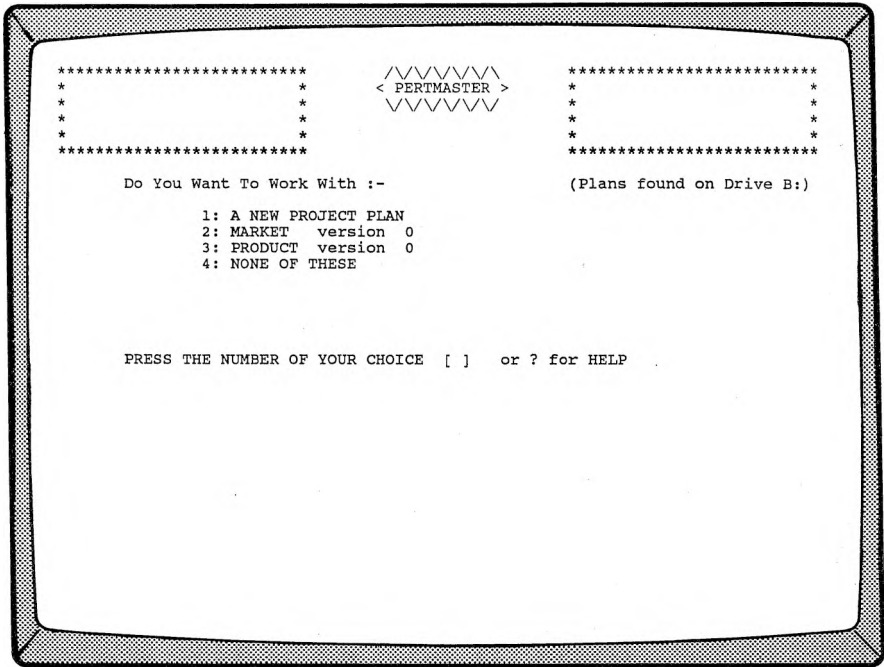

This is a list of all of the plans on your disk. We have supplied two sample plans, MARKET and PRODUCT, at least one of which you will use later.

In the meantime, you want to create a new plan, so type *I* to select **A NEW PROJECT PLAN**. After another short delay, a new menu will be displayed.

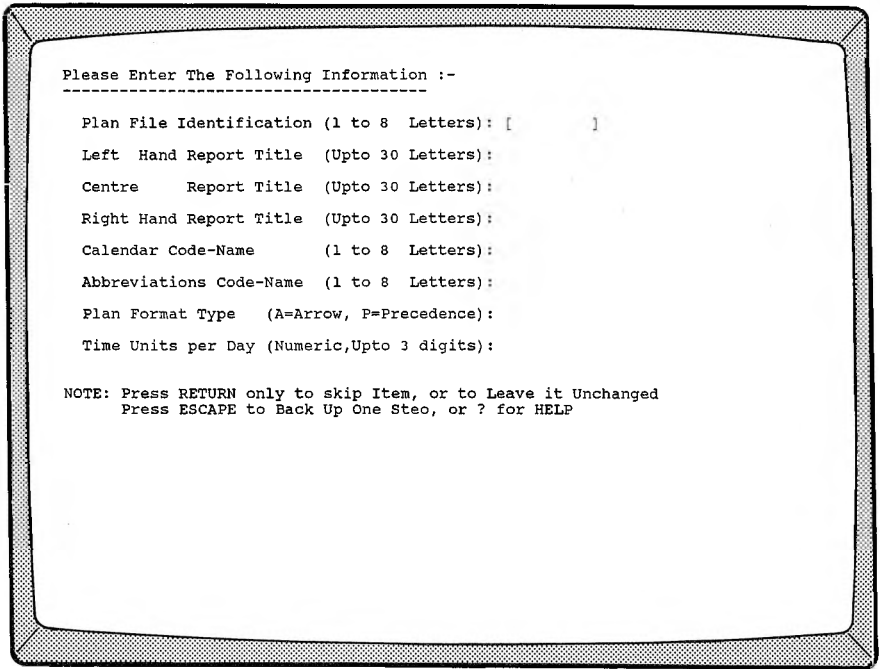

```
Please Enter The Following Information :-
-----
Plan File Identification (1 to 8 Letters): [      ]
Left Hand Report Title (Upto 30 Letters):
Centre Report Title (Upto 30 Letters):
Right Hand Report Title (Upto 30 Letters):
Calendar Code-Name (1 to 8 Letters):
Abbreviations Code-Name (1 to 8 Letters):
Plan Format Type (A=Arrow, P=Precedence):
Time Units per Day (Numeric,Upto 3 digits):

NOTE: Press RETURN only to skip Item, or to Leave it Unchanged
Press ESCAPE to Back Up One Steo, or ? for HELP
```

Here is where you enter all of the information which will allow **PERTMASTER** to recognize your plan and to print out the titles that you want to appear on reports.

Initially, the cursor on your terminal will be positioned at the bracket to the right of the first item, **Plan File Identification**. This is the name you want to use to identify your plan. The name you choose cannot exceed eight characters, must start with a letter, may not contain a space, and otherwise contain only letters or numbers. Let's call this plan **LAUNCH**, so type the word **LAUNCH** and press **◀RETURN▶**.

The cursor will move to the next line, **Left Hand Report Title**. Here, and at the next two lines, you can enter any descriptive titles that you wish to appear on report. For this example, type **XYZ Products, Inc.** and press **◀RETURN▶**.

For the **Centre Report Title** (this program was written in Great Britain!), type *SUPER-WIDGET* and press **◀RETURN▶**. Then type *Menlo Park, CA* for the **Right Hand Report Title** and again press **◀RETURN▶**.

The cursor will now be at the **Calendar Code-Name** line. Remember that we told you that PERTMASTER needed a calendar to be used in each plan, that we supplied a sample calendar file called DAILY.CAL, and that you needed only to know the first part of the file name. Therefore, type *DAILY* to enter the calendar code-name, and press **◀RETURN▶**.

Similarly, the abbreviations file supplied on your disk is named ABBREV.COD. So you should type *ABBREV* to enter the **Abbreviations Code-Name**, followed by **◀RETURN▶**.

Next you must enter the **Plan Format Type**. Since you are working with an Arrow Plan, type *A*.

The last line, **Time Units per Day**, will already have the number *1* entered. You want your plan to be executed in single-day units, so simply press **◀RETURN▶** to leave this line unchanged. Your screen should now look like this.

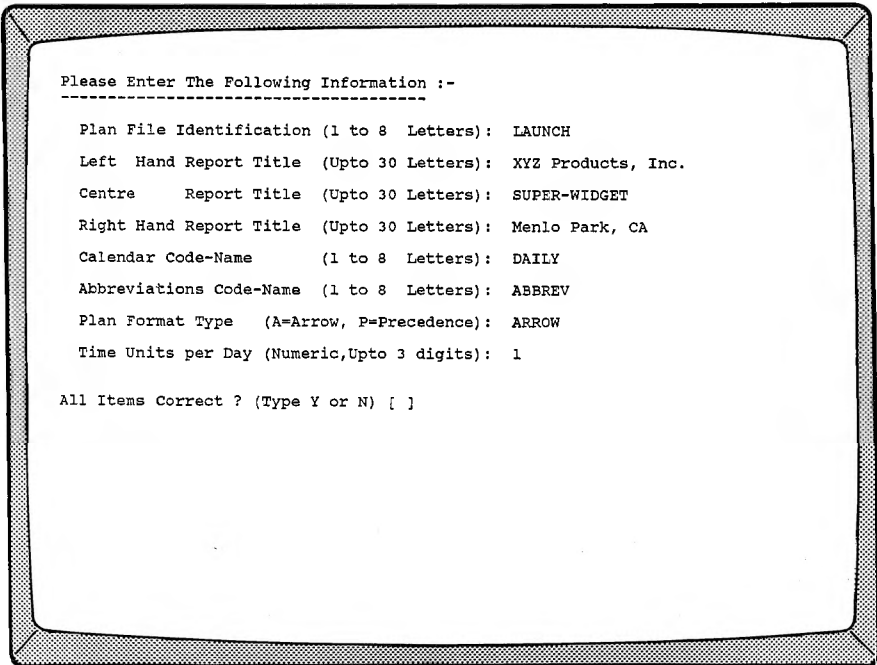

```
Please Enter The Following Information :-  
-----  
Plan File Identification (1 to 8 Letters): LAUNCH  
Left Hand Report Title (Upto 30 Letters): XYZ Products, Inc.  
Centre Report Title (Upto 30 Letters): SUPER-WIDGET  
Right Hand Report Title (Upto 30 Letters): Menlo Park, CA  
Calendar Code-Name (1 to 8 Letters): DAILY  
Abbreviations Code-Name (1 to 8 Letters): ABBREV  
Plan Format Type (A=Arrow, P=Precedence): ARROW  
Time Units per Day (Numeric,Upto 3 digits): 1  
  
All Items Correct ? (Type Y or N) [ ]
```

Now PERTMASTER will ask

All Items Correct ?

At this time, check your entries very carefully. If there is a mistake on any of the lines, type *N* (No), and you will be returned to the top of the menu. Press ◀RETURN▶ until the cursor is at the incorrect line. Then type over the incorrect entry (you can use the space bar to delete unwanted characters) and press ◀RETURN▶ again until you reach the bottom of the list. When all of the entries are correct, type *Y* (Yes).

Entering Plan Activities in PERTMASTER

As soon as you tell PERTMASTER that all of your preliminary entries are correct, the following screen will appear.

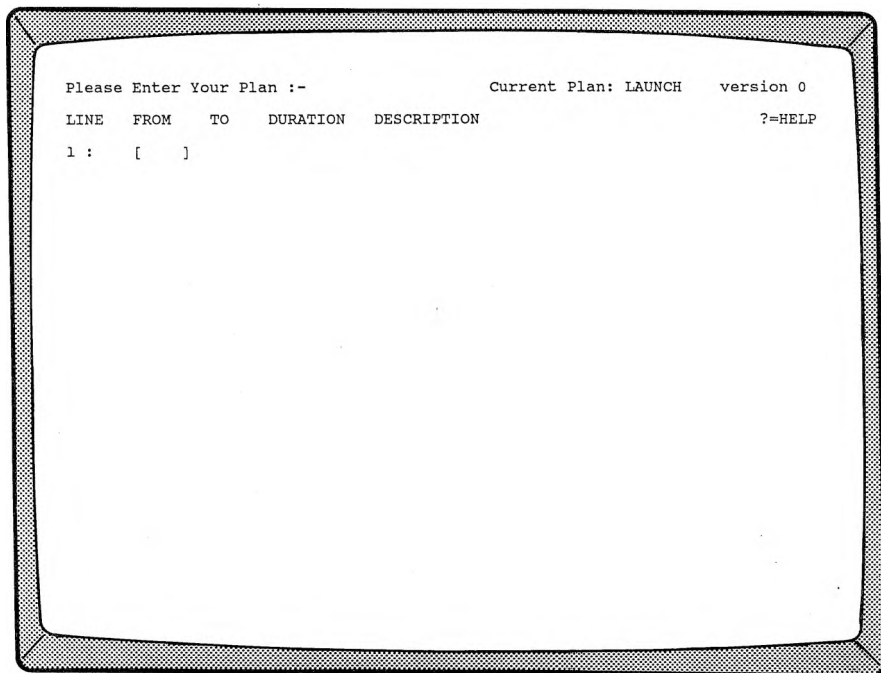

The plan name and version number are shown at the top right corner. Since this is a new plan, the version number is **0**.

The column under the word **LINE** will show a line number for each line that you enter in your plan, will start at **1** for a new plan, and will

increment by one each time you type a line. (After 19 lines, a new screen display is initiated, starting over again at line 1.) You do not type the line numbers; they appear automatically. Now let's start entering the data for the activities on our paper plan.

NOTE: If you make a mistake while typing, and the cursor has not moved to the succeeding line, press ◀**ESCAPE**▶. This will "erase" the entire line, allowing you to retype it.

If you notice a mistake in a line which you have already typed, just make a note of it. We'll tell you how to correct it when you have finished entering your plan.

Every plan must have a start and a finish, so type **S** and press ◀**RETURN**▶. PERTMASTER will immediately replace this with the word **START** in the **FROM** column and the cursor will move to the **TO** column. Since the starting node on the plan is node 5, type **5** and press ◀**RETURN**▶. Because a start has no duration, the cursor will skip that column and move to the **DESCRIPTION** column, where you will be asked

SCHEDULED (Y/N)

Type **N** (No) to indicate that you have not scheduled a starting date. The cursor will now be on line 2.

Although activities do not have to be entered in any specific order, PERTMASTER works faster if they follow a normal time sequence. Let's begin with activity 5-10. In the **FROM** column, type **5** to specify the start of the activity, then press ◀**RETURN**▶. In the **TO** column, type **10** to indicate the end of the activity, and again press ◀**RETURN**▶.

The cursor will now be at the **DURATION** column, so you should type **4** to specify the duration of activity 5-10, and press ◀**RETURN**▶ once more. When the cursor is at the **DESCRIPTION** column, type *Approve Product Design*, which is the description of activity 5-10, and press ◀**RETURN**▶.

NOTE: To save typing time and computer memory, abbreviations are normally entered in place of full descriptions. We will discuss the use of abbreviations in Chapter 6.

Next enter activity 10-20 in the same manner, remembering to press ◀**RETURN**▶ after each entry. Type **10** in the **FROM** column, type **20** in the **TO** column, type **6** in the **DURATION** column, and type *Prepare Sales Documents* as the **DESCRIPTION**.

Now we come to activity 20-30, which is a dummy. Type **20** and **30** in the **FROM** and **TO** columns, respectively. However, a dummy has no duration, so just press ◀**RETURN**▶ when the cursor is at the **DURATION** column.

This will result in a duration of 0. When the cursor moves to the **DESCRIPTION** column, press ◀RETURN▶ again and the word **DUMMY** will appear automatically.

Now that you know how to do it, enter activities 10-30, 10-40, 10-45, 30-40, and 40-45. PERTMASTER allows you to press ◀RETURN▶, instead of typing the preceding node number, when the last-used preceding node is to be used again. This means you can enter multiple activities from a node without having to retype the node number. Thus, after entering activity 10-30, you could enter activities 10-40 and 10-45 by pressing ◀RETURN▶ when the cursor is in the **FROM** column.

To tell PERTMASTER that the plan is finished, type **45** in the **FROM** column and press ◀RETURN▶. Then type **F** in the **TO** column and press ◀RETURN▶ again. The word **FINISH** will appear in place of **F** and the cursor will move to the **DESCRIPTION** column, skipping **DURATION** because a finish has no duration. Again, PERTMASTER will ask

SCHEDULED (Y/N)

This time, type **Y** (Yes). You will then be asked to reply to

NOT AFTER DAY

which should be the day number by which the plan is to be completed. Normally, you would check your calendar file to determine the day number of the calendar date by which the plan is to be completed. Because we will not look at a calendar file until a later chapter, we will assume that the start of our plan will be on day 1.

LAUNCH is a very simple plan, so it is easy to see that it must be finished in 34 days (4 days for activity 5-10, plus 30 days for activity 10-45). Therefore, type **34** in response to PERTMASTER's query, and press ◀RETURN▶.

The cursor will now be at line 11. Since your plan is finished, press ◀ESCAPE▶. PERTMASTER will then display the entire plan, which should look like this.

| LINE | FROM | TO | DURATION | DESCRIPTION | ?=HELP |
|------|---------|----------|----------|-------------------------|--------|
| 1 : | START-> | 5 | | UNSCHEDULED | |
| 2 : | 5 | -> 10 | 4 | Approve Product Design | |
| 3 : | 10 | -> 20 | 6 | Prepare Sales Documents | |
| 4 : | | -> 30 | 10 | Train Sales Force | |
| 5 : | | -> 40 | 15 | Appoint Distributors | |
| 6 : | | -> 45 | 30 | Produce First Units | |
| 7 : | 20 | -> 30 | 0 | DUMMY | |
| 8 : | 30 | -> 40 | 5 | Sales Conference | |
| 9 : | 40 | -> 45 | 10 | Product Launch | |
| 10 : | 45 | ->FINISH | | NOT AFTER DAY 34 | |

You can see that the plan has been rearranged in order of the starting nodes, and that nodes which start more than one activity are not repeated. Check it very carefully for errors, especially typing mistakes, and note the incorrect line(s).

Press **<ESCAPE>** and PERTMASTER will ask you to

Enter a New Time Day Now Number

with the number **1** already entered. Because this is a new plan, PERTMASTER assumes that it is being created as of day 1 of the plan. This being so, press **<RETURN>** instead of retyping the number 1. The next menu shown in this chapter will appear.

CORRECTING YOUR PLAN

If you did not make any mistakes in typing the entries for your plan, you can skip this part and proceed directly to the paragraph titled "GETTING A SCREEN REPORT." However, if you are like most of us, you will have made a typing error. If so, you can correct it as follows.

Type **2** to **Save the Plan and Continue Updating**. Your plan will again be displayed on the screen.

If the error is in the **DURATION** or **DESCRIPTION** column, type the **LINE** number which is to be changed and press **◀RETURN▶**. The cursor will move to the **DURATION** entry. If the entry is correct, simply press **◀RETURN▶** to move to the next column. Correct either entry by typing over the existing data (you can use the space bar to delete unwanted characters), and press **◀RETURN▶**. When the cursor moves to the next line, press **◀ESCAPE▶**.

To correct any other error, you must delete the existing line and type a new one. To do this, type **D** followed by the **LINE** number which is to be changed (e.g. type **D7** to delete line 7), and press **◀RETURN▶**. The cursor will move to that line, where you must again press **◀RETURN▶**. **PERTMASTER** will redisplay the plan with the line deleted.

Now type **I** to insert a new line. A new screen display will allow you to completely reenter the corrected line, just as if you were entering the line in a new plan. When the cursor moves to the next line, press **◀ESCAPE▶**.

As soon as you press **◀ESCAPE▶**, the corrected plan will be displayed. Again press **◀ESCAPE▶** and then press **◀RETURN▶** as the response to

Enter a New Time Day Now Number.

```
*****
*                               *
*      <  \/\\/\  \/\\/\  >    *
*      <  PERTMASTER  >      *
*      \/\\/\  \/\\/\  >    *
*                               *
* Current Plan :LAUNCH *
* Status       :SAVED *
*                               *
*****

SELECTIVE REPORTING FACILITY - SCREEN REPORT

Enter the KEY on which to Select Activities & its Location:-

(1) Selection Key      :[                ]

(2) Starting Location :

Press RETURN if you would like all activities to be printed      ? = HELP
```

This menu allows you to limit the activities which will show up on the report. Since you are working with a very small plan, simply press **◀RETURN▶** to have all of the activities printed on the report. At that time, the Report Menu will reappear with **SCREEN REPORT** listed under **Reports Ordered So Far:**

To see this report before asking for printed reports, select the option **Start** or **Cancel the Run** by typing **8**. PERTMASTER will then tell you to:

PRESS RETURN TO START THE RUN, ESC TO CANCEL

Since you want to see the report, press **◀RETURN▶** and PERTMASTER will display a barchart which looks similar to one of those shown on the following pages.

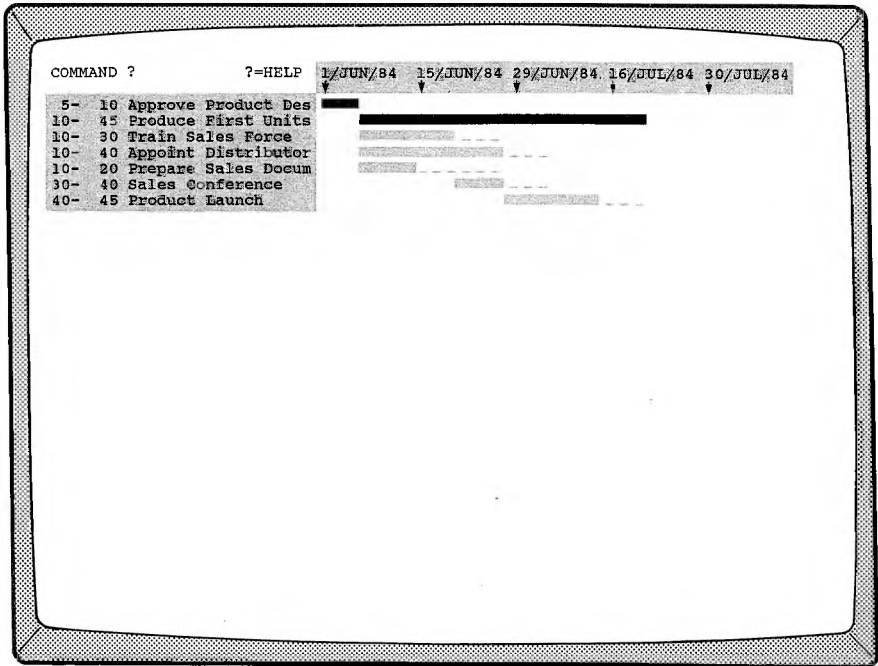

We previously told PERTMASTER to start the report at day 1, which turns out to be 1 June 1984 because that is the first working day in our calendar file (DAILY.CAL). Also, the number of days between the dates along the top of the report are working days; the calendar file allows you to specify working and non-working days.

The report also shows that all of the activities except **Approve Product Design** and **Produce First Units** have float, indicated by the dots or underscores which trail the bar for each activity. This means that any of those activities could be delayed, up to the date at which the float ends, without delaying the finish of the plan.

To leave the Screen Barchart and get some printed reports, press ◀ESCAPE▶. PERTMASTER will then ask you to

Please press Y if you want more reports
Press N if you do NOT

Type *Y* (Yes) to return to the Report Menu.

GETTING SOME PRINTED REPORTS

We will now print out two reports on your printer. **BE SURE THAT THE PRINTER IS TURNED ON AND IS "ON LINE"** before you continue. If it is not "on line," or if you don't have a printer connected to your computer, the computer will "hang up" and you will have to reset it.

The first report which we will print is the **Standard Report Listing**, which you select by typing *1*. The Sort Option Menu, which appeared when you asked for a Screen Report, will reappear. Again choose option *1* to have the report list **The Earliest Activities First**.

Next, the Selective Reporting Menu will be displayed. As with the Screen Report, we want to show all activities, so just press **◀RETURN▶**. The Report Menu will reappear, with **STANDARD REPORT** listed under **Reports Ordered So Far**:

PERTMASTER allows you to print out a maximum of ten reports at once, so you can keep on selecting reports. Since you have already seen the Screen Barchart, pick option *2* to get printed **Project or Period Barcharts**. Again, the menu will appear which will allow you to choose the order in which the activities will appear. This time, type *3* to see **The Most Critical Activities First**.

Again, a Selective Reporting Menu will be shown. And again, press **◀RETURN▶** so that all activities show on the report. A new display, the Barchart Report Menu, will now appear.

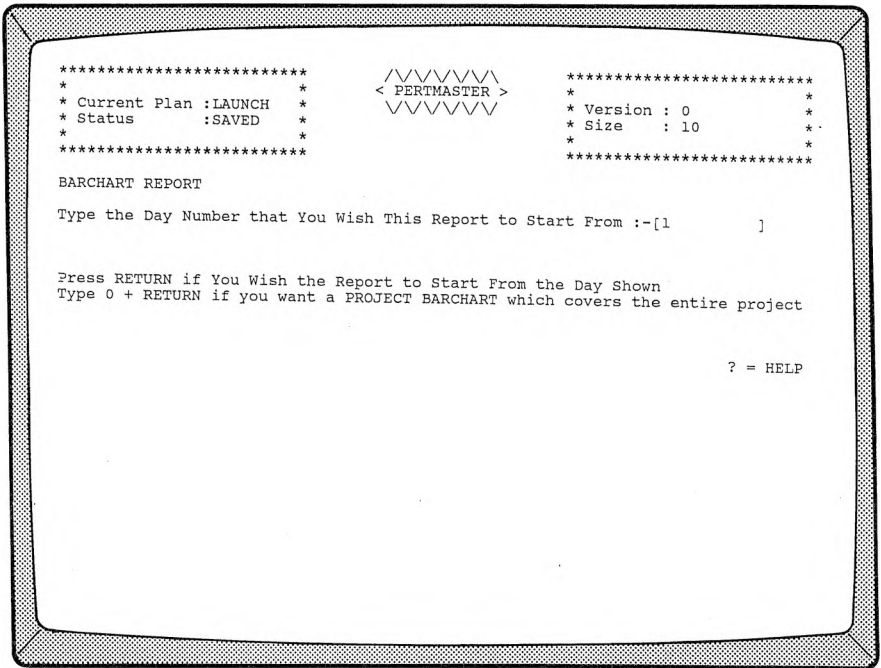

In order to see a Period Barchart which starts at day 1, again press **◀RETURN▶**. Once more, the Report Menu will appear, this time with **PERIOD BARCHART** also listed under **Reports Ordered So Far**.

To print out both of the reports ordered so far, type **8** and press **◀RETURN▶**. **BE SURE THAT YOUR PRINTER IS ON!** The Standard Report will be printed first, followed immediately by the Period Barchart. PERTMASTER will then ask you to

Please press Y if you want more reports
Press N if you do NOT

Type **N** and you will be returned to the Main Menu.

NOTE: If you had to change disks when you started asking for reports, PERTMASTER will instruct you to

Please Insert Disk 1 In the Default Drive
Press RETURN when this has been done.

before returning to the Main Menu.

Let's look at the Standard Report Listing. Yours should look the the one below.

| XYZ Products, Inc. REPORT TYPE :STANDARD LISTING | | SUPER-WIDGET | | | | Menlo Park, CA. | |
|---|----------------|---|--------------|---------------|----------|-----------------|--|
| PLAN I.D. :LAUNCH VERSION 0 | | PRINTING SEQUENCE : Earliest Activities First | | | | | |
| | | SELECTION CRITERIA:ALL | | | | | |
| | | TIME NOW DATE :1/JUN/84 | | | | | |
| ACTIVITY DESCRIPTION | EARLIEST START | EARLIEST FINISH | LATEST START | LATEST FINISH | DURATION | FLOAT | |
| 5- 10 Approve Product Design | 1/JUN/84 | 6/JUN/84 | 1/JUN/84 | 6/JUN/84 | 4 | 0 * | |
| 10- 45 Produce First Units | 7/JUN/84 | 19/JUL/84 | 7/JUL/84 | 19/JUL/84 | 30 | 0 * | |
| 10- 30 Train Sales Force | 7/JUN/84 | 20/JUN/84 | 14/JUN/84 | 27/JUN/84 | 10 | 5 | |
| 10- 40 Appoint Distributors | 7/JUN/84 | 27/JUN/84 | 14/JUN/84 | 5/JUL/84 | 15 | 5 | |
| 10- 20 Prepare Sales Documents | 7/JUN/84 | 14/JUN/84 | 20/JUN/84 | 27/JUN/84 | 6 | 9 | |
| 30- 40 Sales Conference | 21/JUN/84 | 27/JUN/84 | 28/JUN/84 | 5/JUL/84 | 5 | 5 | |
| 40- 45 Product Launch | 28/JUN/84 | 12/JUL/84 | 6/JUL/84 | 19/JUL/84 | 10 | 5 | |

All of the plan activities are listed, with the earliest and latest start and finish dates. Each of the critical activities, **Approve Product Design** and **Produce First Units**, is marked with an asterisk in the **FLOAT** column and shows no difference between its earliest and latest dates, since it has zero float. The other activities have float. This report tells you the latest date that each might be started without affecting the end date of the project.

The Period Barchart should look like the following.

| XYZ Products, Inc. REPORT TYPE :PERIOD BARCHART | | SUPER-WIDGET | | | | | | | | | | | | Menlo Park, CA. | |
|--|---|--|--|--|--|--|--|--|--|--|--|--|--|-----------------|--|
| PLAN I.D. :LAUNCH VERSION 0 | | PRINTING SEQUENCE : Most Critical Activities First | | | | | | | | | | | | | |
| | | SELECTION CRITERIA:ALL | | | | | | | | | | | | | |
| | | TIME NOW DATE :1/JUN/84 | | | | | | | | | | | | | |
| PERIOD COMMENCING DATE | 11 111 118 125 12 19 116 123 130 16 113 120 127 13 1 | | | | | | | | | | | | | | |
| MONTH | 1JUN 1 1 1 1JUL 1 1 1 1AUG 1 1 1 1 1 | | | | | | | | | | | | | | |
| PERIOD COMMENCING TIME UNIT | 11 17 112 117 122 126 131 136 141 146 151 156 161 166 1 | | | | | | | | | | | | | | |
| 5- 10 Approve Product Design | 10000 1 1 1 1 1 1 1 1 1 1 1 1 1 1 | | | | | | | | | | | | | | |
| 10- 45 Produce First Units | 1 C1000001000010000100001000010000 1 1 1 1 1 1 1 1 1 1 | | | | | | | | | | | | | | |
| 10- 30 Train Sales Force | 1 ==1=====1... 1 1 1 1 1 1 1 1 1 1 1 1 1 1 | | | | | | | | | | | | | | |
| 10- 40 Appoint Distributors | 1 ==1=====1... 1 1 1 1 1 1 1 1 1 1 1 1 1 1 | | | | | | | | | | | | | | |
| 30- 40 Sales Conference | 1 1 1 1 ==1=====1... 1 1 1 1 1 1 1 1 1 1 1 1 | | | | | | | | | | | | | | |
| 40- 45 Product Launch | 1 1 1 1 1 ==1=====1... 1 1 1 1 1 1 1 1 1 1 1 1 | | | | | | | | | | | | | | |
| 10- 20 Prepare Sales Documents | 1 ==1=====1... 1 1 1 1 1 1 1 1 1 1 1 1 1 1 1 | | | | | | | | | | | | | | |

Barchart Key:- OCC :Critical Activities == :Non Critical Activities NNN :Activity with Neg Float ... :Float

On this report, the critical activities are shown first because that's what we told PERTMASTER to do. The bars for critical activities are printed using a series of **C**'s. The bars for the non-critical activities consist of equal signs, with float shown as dots. Float is interpreted exactly the same as on the Screen Barchart.

Also, day 1 is shown as 1 June 1984 because, as with the Screen Barchart, that is the first working day in our calendar file.

SUMMARY

Although you have been working with a simple plan, what you have learned is applicable to any Arrow Plan. You now know how to start a new plan, enter its activities, and get reports. Next, you will learn more about plans, as well as how to change a plan, which you will probably do much more often than creating a new one.

WHY CHANGES ARE MADE

In Chapter 5 you learned how to enter a new plan, albeit a very simple one. In all likelihood, you also used PERTMASTER's change capability to correct your errors, although you may not have realized that at the time. Since plans are dynamic — that is, they generally must change as time goes by, for any number of reasons — PERTMASTER provides a varied menu of change options. In this chapter, we are going to tell you how to make changes and will introduce you to some additional features which you will need when you create more complex plans.

In order to explain these features, we will use a plan which already exists on your PERTMASTER Data Disk. You will see that making changes is basically no different than entering a new plan; using the existing plan will save you the tedium of typing a more complicated new plan.

On the facing page we have shown the graphic network from which the computer plan was derived. By comparing the plan listing with this network, you will be able to see the exact correlation between the two.

Your first step is to call up PERTMASTER if you have not already done so. Then select option *I*, **Produce an Up-to-Date Plan**, from the Main Menu. From the list of plans that will then be displayed, enter the option number for **MARKET**, our sample Arrow plan. The first nineteen lines of that plan will appear. If you had just entered the plan, you would have gotten the identical display immediately after you had pressed ◀**ESCAPE**▶ to signify the end of the plan.

To see the next nineteen lines, press ◀**RETURN**▶. Notice that the line numbers are repeated, even though the plan activities have changed. Again press ◀**RETURN**▶ and the remaining activities will be shown.

HELP MENU

Before continuing, let's look at PERTMASTER's Help Menu. Do this by typing ? (question mark). The following screen display will appear.

The COMMANDs Available are as Follows :-

- line - By entering a line number only, the duration, dates and/or the description of the activity on that line may be changed. The cursor will go to the items in turn, and you may enter a new value or just press RETURN to leave unchanged. When RESOURCES are selected another change can be made to the next line.
- I - INSERT will allow you to enter details of more activities. The screen will clear and you should enter your new activities.
- H - HEADINGS will allow changes to the Plan heading details.
- RES - RESOURCES will cause the display of any resource details. You can then change or enter them using the line command.
- DES - DESCRIPTIONS will return you back to the normal display.
- Dline - DELETE allows the line entered to be removed. The cursor will jump to the line, press RETURN to delete or ESCAPE to cancel. You could type D12 to delete line 12 for example.
- RETURN- By pressing return only, the next 19 lines will be displayed.
- Gx - Goto will cause the 19 lines starting at the node/activity x to be displayed.
- ESCAPE- Pressing this key will end this section. You will be asked to enter a new time now value, and then you may save this version.

Press any Key to Continue

These are the commands which will enable you to make changes to a plan, once it has been entered. You will make extensive use of them as you use PERTMASTER, and eventually will remember most of them. Until then, you can always type a question mark to refresh your memory.

At this time, some of the commands may appear to be cryptic, because of space limitations of the screen. However, as you go through the procedures in this chapter (and in some of the subsequent ones), the commands will become quite clear. You have already used the **RETURN** command to see the lines on the plan which were not displayed initially.

Now let's go back to the beginning of the plan. Press any key to erase the Help Menu. You will again see the last part of the plan displayed. The cursor will be at the **COMMAND** line at the top of the screen, indicating that PERTMASTER is awaiting your command.

To go to any point in the plan, the **Gx** command is used. "G" means "go to" and the "x" signifies the starting node number. However, if you want to go to the beginning of the plan, you can always use a zero in place of

the actual number. Therefore, type *G0* and press RETURN; PERTMASTER will once more display the first nineteen lines of the plan.

| COMMAND? [] | | Current Plan: MARKET | | version 0 |
|--------------|---------|----------------------|----------|----------------------------------|
| LINE | FROM | TO | DURATION | DESCRIPTION |
| 1 : | START-> | 1 | | UNSCHEDULED |
| 2 : | 1 | <-MILESTONE | | START PRODUCT PLANNING |
| 3 : | | -> 2 | 3 | GM Develop !PR Design Concepts |
| 4 : | | -> 3 | 3 | GM Develop !PR Marketing Plan |
| 5 : | | -> 4 | 6 | GM Create !PR Business Plan |
| 6 : | 2 | -> 4 | 3 | GM Develop Production Plan |
| 7 : | 3 | -> 4 | 3 | GM Negotiate License Agreement |
| 8 : | 4 | -> 5 | 2 | GM Approve !PR Plans and Design |
| 9 : | 5 | <-MILESTONE | | FINISH INITIAL PLANNING |
| 10 : | | -> 6 | 3 | GM Create and Approve !PR Budget |
| 11 : | 6 | -> 7 | 3 | GM Appoint !PR Manager |
| 12 : | 7 | <-MILESTONE | | READY TO INITIATE PRODUCT PLANS |
| 13 : | | -> 8 | 3 | MP Order !PR Materials |
| 14 : | | -> 9 | 3 | MD Design !PR Package |
| 15 : | | -> 10 | 4 | MS Hire !SS |
| 16 : | | -> 25 | 6 | MS Appoint Distributors |
| 17 : | 8 | -> 12 | 4 | MP Setup !PR Production |
| 18 : | 9 | -> 11 | 1 | MD Approve !PR Package Design |
| 19 : | 10 | -> 25 | 2 | MS Train !SS |

CHANGING ACTIVITY DURATIONS

Probably the changes that you will make most often will be in the durations of activities. You will normally reduce durations as the work progresses. You may have to increase the duration of an activity because you have changed the estimate of time that an activity will take.

Let's assume that activity **3-4, Negotiate License Agreement**, in the MARKET plan will take two more days than originally planned. (For the time being, we will ignore the two-letter codes which precede the descriptions.) Therefore, the duration of the activity must be changed to five days. To enter this in the plan, type the **LINE** number to be changed, in this case 7, and press **<RETURN>**. The cursor will move to the **DURATION** column. Type 5, the new duration, and press **<RETURN>**.

The cursor will then move to the **DESCRIPTION** column, where you could type in a new description if you wanted to do so. Since we are changing

only the duration, press **◀RETURN▶** again, and the cursor will return to the command line, leaving the description unchanged.

Refer to the plan drawing and note that the duration of each path between nodes 1 and 6 is six days. By changing the duration of activity 3-4, you have increased the duration of one path to eight days. Therefore, you can expect this to affect your schedule. Although the effect of the change is obvious in this particular plan, it might not be so in another. Nonetheless, PERTMASTER will recalculate the schedule when you save the changed plan.

DELETING AND ADDING ACTIVITIES

Activities are often added or deleted as a project progresses and more data become available. We can use our sample plan to demonstrate how this is accomplished.

First, type *G15* in order to display activity 16-24. Then, as an example, suppose that this activity is to be split into two separate activities, so that samples can be obtained before the orders are placed. To do this, the original activity must be deleted so that two new ones can take its place.

To delete the activity, use the **D** (Delete) command, followed by the **LINE** number of the activity to be deleted. Since activity 16-24 is on line 5, type **D5**, and press **◀RETURN▶**. The cursor will move to that line, giving you the opportunity of changing your mind. If you press **◀ESCAPE▶**, the delete command will be cancelled. To delete the line, which we have decided to do, press **◀RETURN▶**.

Now you must insert two new activities, which we will designate 16-30, MD Order Sample Binders and Cases, and 30-24, MD Order Production Binders and Cases. Note that we will maintain a path from node 16 to node 24, but will insert a new node between them.

Type **I**, which is PERTMASTER's Insert command, and press **◀RETURN▶**. The resulting display is the same one used to enter a new plan. However, you need only type the activities which you are adding. As with entering a new plan, type **16** in the **FROM** column, **30** in the **TO** column, use a duration of **10** in the **DURATION** column, and type **MD Order Sample Binders and Cases** as the description. Press **◀RETURN▶** after each entry.

Similarly, enter activity **30-24** on the next line, using a duration of **20** and **MD Order Production Binders and Cases** as its description. When the cursor moves to the next line, press **◀ESCAPE▶** to indicate that there are no more activities to be added. The plan listing will reappear, with the new lines properly sequenced.

ADDING MILESTONES

Although we did not incorporate them in the new plan that you entered in Chapter 5, every plan should include milestones. Milestones are key dates within a project. They are selected to provide certain management levels with overall, rather than detailed, information. The number of milestones used in a typical plan should normally be between five and ten percent of the number of activities.

If you refer to the plan listing for MARKET, you will see several milestones listed. Press ◀RETURN▶ until the end of the plan appears. A milestone at the finish, which is normally included, is missing. Let's add it.

You add a milestone by using the **I** command, since it is being inserted. Then, on the first line of the ensuing display, type **28**, which is the node for the finish, and press ◀RETURN▶. When the cursor moves to the **TO** column, simply type **M** and a ◀RETURN▶. The word **MILESTONE** will appear, and the cursor will be at the **DESCRIPTION** column. Since a milestone is a key date, not an activity, it has no duration.

At this point, type a suitable description, such as **PROJECT COMPLETE**, and press ◀RETURN▶. After the cursor moves to the next line, press ◀ESCAPE▶ to indicate that you are finished. When the plan is redisplayed, it will include the added milestone.

Milestones are generally used to signify the completion of a major portion of a plan, but can be used anywhere that you consider applicable. The node number that is to made a milestone is always entered in the **TO** column.

ADDING STARTS AND FINISHES

As you learned in Chapter 5, every plan must have at least one start and at least one finish. They may be scheduled or unscheduled, and may be changed. Once a project is underway, an unscheduled start should be scheduled.

Adding extra starts or finishes to your project is the way in which network analysis allows you to place time constraints on your work. By using scheduled starts you can make any activity start on or after a certain date. By using scheduled finishes you can force any activity to finish by a fixed date. Thus a combination of scheduled starts and scheduled finishes will allow you to achieve any form of time constraint that you want, including specifying that an activity must happen on a specific date.

If you are not at the beginning of the plan, type **G0**, then press ◀RETURN▶, to go there. In our sample plan, both the start and finish

are unscheduled. At this time, we will assume that our project has started and that we want to change to a scheduled start.

This is a good time to look at a PERTMASTER calendar. As we told you earlier, a calendar file titled DAILY has been supplied on your Data Disk and is the one which is used in the plan MARKET. A printout of the first six months of the calendar is shown below.

| PERTMASTER - LISTING OF CALENDAR DAILY | | | | | | | | | | | | | | | | | | | | | | | | | | | | | |
|--|-----|-----|-----|-----|-----|-----|-----------------|------|-----|-----------------|-----|-----|-----|-----------------|------|------|-----|-----|-----|-----------------|-----|-----|-----|--|--|--|--|--|--|
| Month :JUN/1984 | | | | | | | | | | Month :JUL/1984 | | | | | | | | | | Month :AUG/1984 | | | | | | | | | |
| Sun | Mon | Tue | Wed | Thu | Fri | Sat | Sun | Mon | Tue | Wed | Thu | Fri | Sat | Sun | Mon | Tue | Wed | Thu | Fri | Sat | | | | | | | | | |
| Date | | | | | 1 | 2 | Date | 1 | 2 | 3 | 4 | 5 | 6 | 7 | Date | | | | | 1 | 2 | 3 | 4 | | | | | | |
| Day | | | | | 1 | --- | Day | --- | 22 | 23 | --- | 24 | 25 | --- | Day | | | | | 43 | 44 | 45 | --- | | | | | | |
| Date | 3 | 4 | 5 | 6 | 7 | 8 | 9 | Date | 8 | 9 | 10 | 11 | 12 | 13 | 14 | Date | 5 | 6 | 7 | 8 | 9 | 10 | 11 | | | | | | |
| Day | --- | 2 | 3 | 4 | 5 | 6 | --- | Day | --- | 26 | 27 | 28 | 29 | 30 | --- | Day | --- | 46 | 47 | 48 | 49 | 50 | --- | | | | | | |
| Date | 10 | 11 | 12 | 13 | 14 | 15 | 16 | Date | 15 | 16 | 17 | 18 | 19 | 20 | 21 | Date | 12 | 13 | 14 | 15 | 16 | 17 | 18 | | | | | | |
| Day | --- | 7 | 8 | 9 | 10 | 11 | --- | Day | --- | 31 | 32 | 33 | 34 | 35 | --- | Day | --- | 51 | 52 | 53 | 54 | 55 | --- | | | | | | |
| Date | 17 | 18 | 19 | 20 | 21 | 22 | 23 | Date | 22 | 23 | 24 | 25 | 26 | 27 | 28 | Date | 19 | 20 | 21 | 22 | 23 | 24 | 25 | | | | | | |
| Day | --- | 12 | 13 | 14 | 15 | 16 | --- | Day | --- | 36 | 37 | 38 | 39 | 40 | --- | Day | --- | 56 | 57 | 58 | 59 | 60 | --- | | | | | | |
| Date | 24 | 25 | 26 | 27 | 28 | 29 | 30 | Date | 29 | 30 | 31 | | | | | Date | 26 | 27 | 28 | 29 | 30 | 31 | | | | | | | |
| Day | --- | 17 | 18 | 19 | 20 | 21 | --- | Day | --- | 41 | 42 | | | | | Day | --- | 61 | 62 | 63 | 64 | 65 | | | | | | | |
| ***** | | | | | | | | | | | | | | | | | | | | | | | | | | | | | |
| Month :SEP/1984 | | | | | | | Month :OCT/1984 | | | | | | | Month :NOV/1984 | | | | | | | | | | | | | | | |
| Sun | Mon | Tue | Wed | Thu | Fri | Sat | Sun | Mon | Tue | Wed | Thu | Fri | Sat | Sun | Mon | Tue | Wed | Thu | Fri | Sat | | | | | | | | | |
| Date | | | | | 1 | 2 | Date | | 2 | 3 | 4 | 5 | 6 | Date | | | | | 1 | 2 | 3 | | | | | | | | |
| Day | | | | | --- | --- | Day | | 85 | 86 | 87 | 88 | 89 | --- | Day | | | | | 108 | 109 | --- | | | | | | | |
| Date | 2 | 3 | 4 | 5 | 6 | 7 | 8 | Date | 7 | 8 | 9 | 10 | 11 | 12 | 13 | Date | 4 | 5 | 6 | 7 | 8 | 9 | 10 | | | | | | |
| Day | --- | --- | 66 | 67 | 68 | 69 | --- | Day | --- | 90 | 91 | 92 | 93 | 94 | --- | Day | --- | 110 | 111 | 112 | 113 | 114 | --- | | | | | | |
| Date | 9 | 10 | 11 | 12 | 13 | 14 | 15 | Date | 14 | 15 | 16 | 17 | 18 | 19 | 20 | Date | 11 | 12 | 13 | 14 | 15 | 16 | 17 | | | | | | |
| Day | --- | 70 | 71 | 72 | 73 | 74 | --- | Day | --- | 95 | 96 | 97 | 98 | 99 | --- | Day | --- | 115 | 116 | 117 | 118 | 119 | --- | | | | | | |
| Date | 16 | 17 | 18 | 19 | 20 | 21 | 22 | Date | 21 | 22 | 23 | 24 | 25 | 26 | 27 | Date | 18 | 19 | 20 | 21 | 22 | 23 | 24 | | | | | | |
| Day | --- | 75 | 76 | 77 | 78 | 79 | --- | Day | --- | 100 | 101 | 102 | 103 | 104 | --- | Day | --- | 120 | 121 | 122 | --- | --- | --- | | | | | | |
| Date | 23 | 24 | 25 | 26 | 27 | 28 | 29 | Date | 28 | 29 | 30 | 31 | | | | Date | 25 | 26 | 27 | 28 | 29 | 30 | | | | | | | |
| Day | --- | 80 | 81 | 82 | 83 | 84 | --- | Day | --- | 105 | 106 | 107 | | | | Day | --- | 123 | 124 | 125 | 126 | 127 | | | | | | | |
| Date | 30 | | | | | | | Date | | | | | | | | Date | | | | | | | | | | | | | |
| Day | --- | | | | | | | Day | | | | | | | | Day | | | | | | | | | | | | | |

--- = NON-WORKING DAY, +++ = PROJECT HAS FINISHED

Note that, in addition to the calendar date, a day number appears for each working day. These are the day numbers which we have mentioned only briefly thus far. Day numbers, not calendar dates, are always entered when PERTMASTER requires a day.

Changing a start or finish is like changing an activity duration, in that you type the line number which is to be changed. Therefore type *I*, which is the line number for the start, then press **◀RETURN▶**. In this instance, however, the cursor will move to the **DESCRIPTION** column, which will now read **NOT BEFORE DAY [0]**.

To schedule a date, enter the day number from the calendar file which the plan uses. In this case, assume that the plan is to start on June 11, which is the seventh working day of the calendar. Therefore, type 7 and press ◀RETURN▶. The plan will now read **NOT BEFORE DAY 7** for the start.

If you want to change the start day again, repeat the procedure and type the new day number over the old one in the brackets. If you want to change from a scheduled start to an unscheduled one, type a zero when the cursor is at the brackets. PERTMASTER will change the start to unscheduled.

Finishes are changed in exactly the same way. The only difference between the two is the statement in the **DESCRIPTION** column, which reads **NOT AFTER DAY []** for finishes.

CHANGING PLAN HEADINGS

When you first entered a new plan, you had to provide PERTMASTER with certain information about the plan — its name, the type of plan, calendar and abbreviations file names, time units per day, and report titles. Although it is not likely that you will ever want to change any of these but possibly the last two, all of them can be changed except for the plan type. You cannot change from an Arrow to a Precedence Plan, or vice versa, without reentering your data in the format dictated by the other type of plan.

To change any of the other details, type *H* when the cursor is at the command line, and press ◀RETURN▶. PERTMASTER will then display the New Plan Menu with all of the entries for the plan shown.

As explained on the screen, you can move the cursor down or up by using the ◀RETURN▶ and ◀ESCAPE▶ keys. You can then change any of the entries, except for the **Plan Format Type**, by typing over the existing words and using the space bar to eliminate any characters at the end. If you try to change the type of plan, PERTMASTER will reject the entry.

Should you elect to change the **Plan File Identification** and save the plan, it will become version **0** under the new name. However, the prior version under the old name will still be retained on your Data Disk.

Exiting this part of the change routine is done in exactly the same way as for a new plan, and returns you to the plan listing.

SAVING OR ABANDONING CHANGES

When you are finished making changes and the cursor is at the command line, press **◀ESCAPE▶** to tell PERTMASTER that there are no more changes. You will then be asked to

Enter a New Time Day Now Number

This would normally be the day number in the calendar file on which you are making the changes. PERTMASTER will always display **1** if there has been no previous change. Under the assumption that these changes are being made on day 7, type 7 and press **◀RETURN▶**.

The Change/Abandon Plans Menu, which you saw in Chapter 5, will be displayed. We don't really want to save the changes that were made, so select option **5, Abandon This Plan and Start Again**. PERTMASTER will warn you that

MARKET version 1 Is About to be Lost Do You Want To Continue ? (Type Y or N)

Respond by typing **Y** and you will be returned to the Main Menu.

USING ABBREVIATIONS

Up to now, you have not used any abbreviations in entering a new plan or in changing the sample plan. Nonetheless, the use of abbreviations, especially in long plans, is extremely important in that there is a considerable savings in the amount of memory which will be used.

If you displayed the New Plan Menu, as described above under Changing Plan Headings, you will have seen that the MARKET plan uses an abbreviations file named ABBREV. Also, as shown in the plan listing shown earlier in this chapter, several descriptions contain entries like **!PR** and **!SS**. These are PERTMASTER's short-hand entries for the abbreviations in abbreviations file ABBREV, shown on the next page.

PERTMASTER

SCHEDULE OF ABBREVIATIONS AND DESCRIPTIONS STORED ON DISK UNDER THE HEADING : ABBREV

| | | | |
|----|-------------------------------------|----|--|
| 1 | PE - Executive Staff | 2 | PM - Product Manager |
| 3 | PS - Sales Staff | 4 | PO - Support Staff |
| 5 | SD - Database Software | 6 | PC - Consultants |
| 7 | SP - Personnel Cost in Dollars | 8 | #S - Shipping Material Cost in \$100s |
| 9 | #C - Consulting Cost in Dollars | 10 | #M - Product Material Cost in \$100s |
| 11 | EC - Computer | 12 | ES - Contracted Equipment |
| 13 | MB - Binders and Cases in Hundreds | 14 | MI - Manual Inserts in Hundreds |
| 15 | MP - Product Materials in Hundreds | 16 | MM - Packaged Manuals in Hundreds |
| 17 | MS - Shipping Materials in Hundreds | 18 | MP - Product ready to ship in Hundreds |
| 19 | SP - PagePlanner Software | 20 | SM - Pertmaster Software |
| 21 | RM - Conference Room | 22 | FT - Contract Cost in \$100s |
| 23 | SL - Sales Literature | 24 | MN - Users manual |
| 25 | AD - Advertising | 26 | PR - Product |
| 27 | SS - Sales Staff | | |

Note that the majority of the entries consist of a two-letter abbreviation, followed by the description, or definition, of the abbreviation. (A few entries use a \$ or # sign as the first character; these will be explained in Chapter 9.)

To save both computer memory and typing time, you should use abbreviations wherever possible. They are entered in the descriptions of activities by preceding the two letters with an exclamation mark, and will appear on the plan listing as such. However, the full description will appear on all of the reports which PERTMASTER generates.

Thus, the description for activity 13-24, which reads **MS Hire ISS**, will be printed as "MS Hire Sales Staff," since "SS" is the abbreviation for "Sales Staff."

The two-letter codes without the leading exclamation mark, which appear in the MARKET plan descriptions, are not abbreviations as defined by PERTMASTER. They have been included to aid in the selection of reports, and will be discussed in Chapter 10.

Whenever you initiate a new plan, you will normally need to create a new abbreviations file or add to an existing file. Complete instructions for doing either appear in Reference Section 5.2. Setting up a dummy abbreviations file, applicable to small plans which may not require abbreviations, will be found in Chapter 11.

SUMMARY

We have now covered all of the basics that you need to know about entering and changing Arrow Plans. However, we still have not discussed one of PERTMASTER's strongest points — resource tracking. While you

do not have to use or track resources in your plans, doing so will increase the usefulness of those plans. Chapter 9 explains resource tracking.

Of course, the whole purpose of PERTMASTER is to provide you with meaningful and useful reports. These are covered in detail in Chapter 10. You should proceed directly to that chapter if you do not want to use resource tracking at this time.

PRECEDENCE NOTATION

In Chapter 3, we discussed graphic networks and showed that an activity is represented by a geometric outline (usually a box) which is linked to the next activity with a line and arrow. Conventionally, the link between activities is shown from left to right.

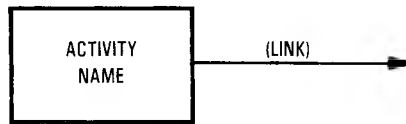

The activity takes a certain amount of time to complete; this time is called DURATION. A link may or may not have duration, as we shall see. Thus, in Precedence Plans we have two building blocks — activities and links.

SIMPLE RELATIONSHIP BETWEEN ACTIVITIES

The network, or PLAN, for a simple relationship involving two activities, would look like this.

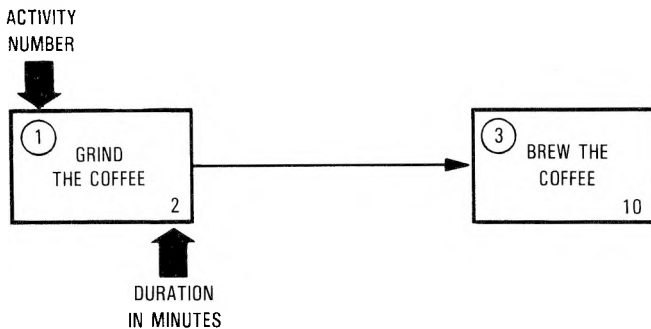

Note that we have given the activities arbitrary numbers, in circles, for reference only. We have also indicated the estimated duration of each activity, which is the number beneath the activity name. Therefore, activity

1 is grinding the coffee, and activity 3 is brewing the coffee. When activity 1 has been completed, having taken two minutes, activity 3 is ready to begin. We can see that activity 3 takes ten minutes. Therefore, the entire plan shows that grinding the coffee precedes brewing the coffee, and that both activities require a time span of twelve minutes.

Because the finish of the first activity controls the start of the next, the link between grinding the coffee and brewing the coffee is known as a FINISH-TO-START link. The link in this plan has no duration.

COMPLEX RELATIONSHIPS

A slightly more complex relationship can be shown as follows.

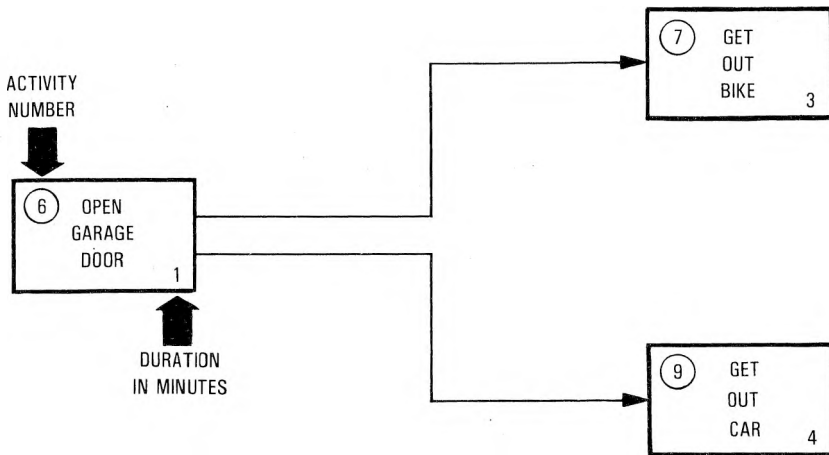

In this case, opening the garage door (activity 6) must be completed before getting out the car (activity 9) and getting out the bike (activity 7) can start. Therefore, getting out the car and getting out the bike both succeed opening the garage door. Neither can begin until the garage door has been opened.

The succeeding activities, which we can refer to as “7” and “9,” are independent of each other. They can go on at the same time, provided that we have a car driver and a bike rider, either of whom could have opened the garage door.

We have also estimated the duration of each activity. So we can see immediately that it will take three minutes to get out the bike, and four minutes to get out the car.

Links can also have duration.

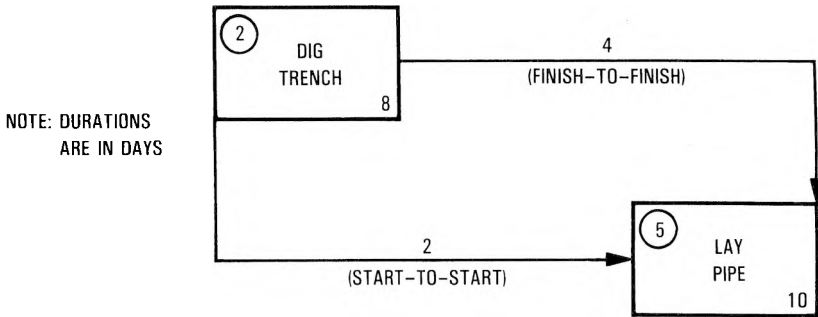

In the above plan, we have drawn a link between the start of digging the trench and the start of laying the pipe, and have shown it to have a duration of two days. This is called a **START-TO-START**, or lead link. It indicates that we can begin laying the pipe two days after we have started digging the trench. Note that a start-to-start link is drawn from and to the left side, or start, of each activity box. The left edge of each box is regarded as the beginning of the activity, while the right side is the end of the activity.

We can link finishes in a similar way with a **FINISH-TO-FINISH**, or lag, link. This indicates that there will still be some time needed to finish the succeeding activity when the preceding activity is complete.

In the example above, digging the trench leads laying the pipe by two days throughout. That is, pipe laying can start when two days' trenching has been done. However, when the trenching is finished, there will still be four days required to finish laying the pipe, since it takes two days longer to lay the pipe than to dig the trench. Therefore, the finish-to-finish link has a duration of four days.

The entire plan will take twelve days to complete. You can calculate this from the durations of the activities and the links.

In more complex relationships, like the one shown below, at least one of the paths through the network will take longer than all the others.

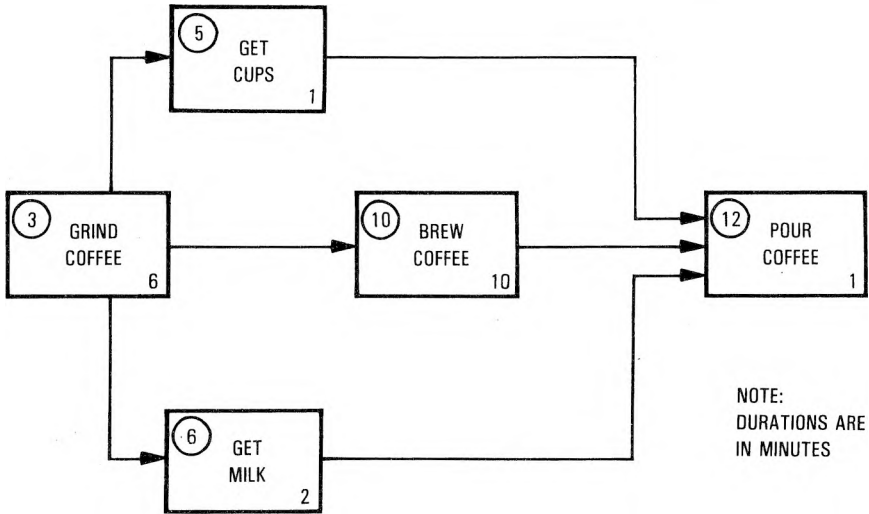

The activities on the longest path must be completed on time if we are to finish the project on time. The longest path is known as the **CRITICAL PATH**. Those activities on the critical path are called **CRITICAL ACTIVITIES**; critical activities are vital to the success of the project.

Other activities — those not on the critical path — can be delayed to some degree without affecting the end date or total time. These activities are said to have **FLOAT**, which is the amount of time that they can be delayed without affecting the end of the project.

In the above plan, grinding the coffee, brewing the coffee, and pouring the coffee are all critical activities, since they are on the critical path. Getting the cups and getting the milk can both be delayed without endangering the schedule. Therefore, both have float.

Large projects can have plans which contain a thousand activities or more. There is a mathematical method of calculating the timing of a plan, but we don't have to concern ourselves about such calculations; **PERTMASTER** does that for us.

CREATING A NEW PRECEDENCE PLAN

The Plan on Paper

You are now ready to start learning how to use PERTMASTER. The best way to start is to create a brand new plan.

We are going to use the following plan, which covers the launch of a new product. It shows the activities necessary to get the product onto the market, once the product has been designed and tested.

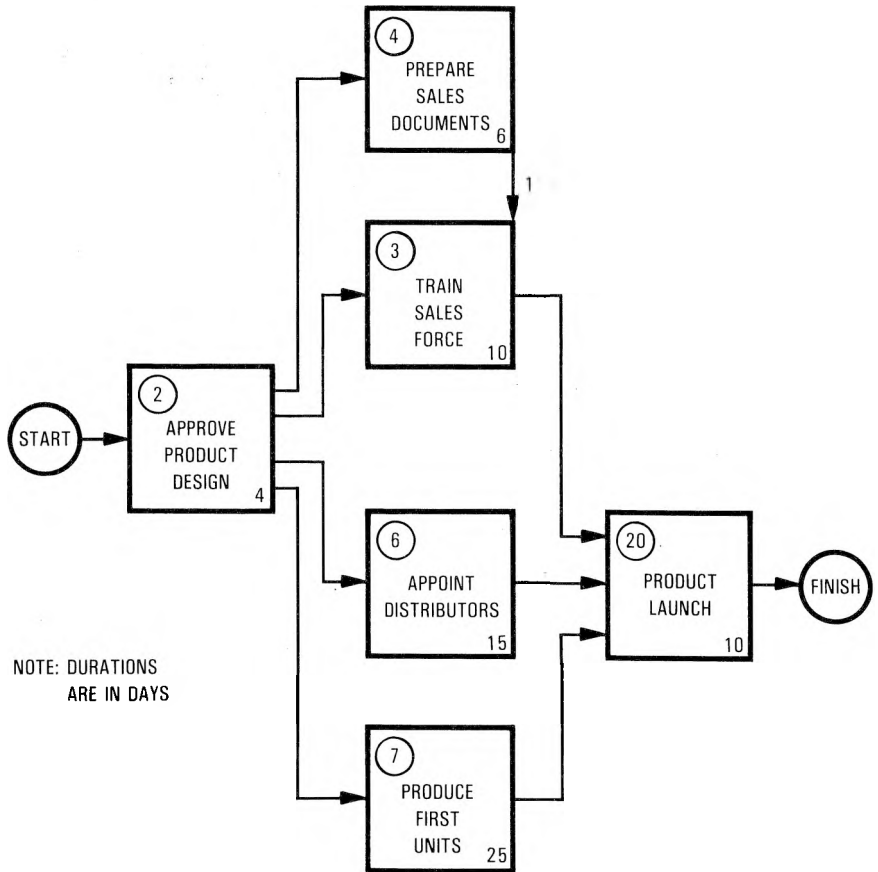

Although the assignment of activity numbers is arbitrary, activity 1 is always reserved for the start. Consequently, any activity number except 1 can be used for any activity.

This plan starts at activity 2, approval of product design. When the product has been approved, an activity which takes four days, four other activities can begin simultaneously.

Activity 4, preparing sales documents, takes 6 days. Activity 3, training sales force, takes 10 days. Activity 6, appointing distributors, takes 15 days. Note that there is a one-day finish-to-finish link from preparing the sales documents to training the sales force. This shows that the sales documents must be completed one day before the end of sales training.

Meanwhile, the appointment of distributors is going on. This also must be completed before the product can be launched.

While all of this is happening, we must produce the first units, which we estimate will take 25 days, and which can begin as soon as the product is approved. The first units must be ready by the start of the product launch, activity 20. However, we must allow another five days for distribution. Therefore, we have given a duration of five days to the finish-to-start link which connects activity 7 to activity 20. The end of activity 20 is the finish of the project.

You are now ready to call up PERTMASTER and enter the data for your plan.

Calling Up PERTMASTER

Be sure to use the working copy of your PERTMASTER disk(s). Then proceed as follows:

1. Turn on your computer and video terminal.
2. Follow the instructions below which apply to the computer system which you are using, then continue with step 3.
 - (a) Single Floppy-Disk Drive
Insert the PERTMASTER disk in the drive and close the drive gate.
 - (b) Two or More Floppy-Disk Drives
 - (1) If PERTMASTER was supplied to you on one disk, place that disk in drive A and place your Data Disk in the drive which was designated the data drive in Chapter 4. Close both drive gates.
 - (2) If PERTMASTER was supplied to you on more than one disk, insert the lowest-numbered disk in drive A and place the Data Disk in the drive which was designated the data drive in Chapter 4. Close both drive gates.

(c) One Hard-Disk Drive and One or More Floppy-Disk Drives

Insert the PERTMASTER disk in the floppy-disk drive. (If you have more than one, refer to your computer manual to find out which is the "default" drive.) Close the drive gate.

NOTE: You must have the PERTMASTER floppy disk in the default drive each time that you want to call up PERTMASTER.

3. When the A-prompt (**A>**) appears on your screen, type **CONTROL** and press **<RETURN>**. With certain computers, this may not be necessary; the word **CONTROL** may appear automatically.
4. After a few seconds, the Copyright Notice should be displayed. A seconds later, or after you press **<RETURN>**, PERTMASTER's Main Menu will appear, and should look something like this.

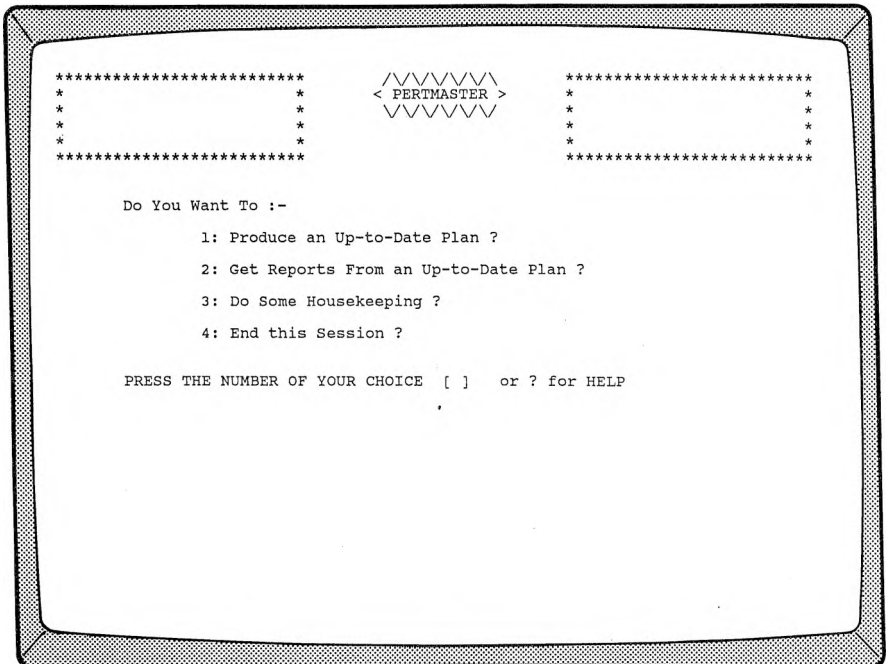

The exact appearance of PERTMASTER's displays will depend on the computer which you are using. However, the wording on the screen will always be the same.

In virtually all of PERTMASTER's menus and screen displays, you will see either

? for HELP

or

? = HELP

This indicates that you can get help on your entries or on what what you want PERTMASTER to do simply by typing a question mark any time either of these two statements is on the screen.

Entering the Plan Identification in PERTMASTER

Now that you have a plan on paper, and PERTMASTER is up and running, you can enter the necessary data to allow the program to calculate the results and print out reports. In doing so, you will find out that PERTMASTER requires you to have a calendar and a list of abbreviations before you can get any reports from your plan.

To make it easier to start, we have included a calendar and a list of abbreviations on your program disk(s). These are in two files on the disk. (A file is related information stored as a single group with a unique name.) The calendar file is named DAILY.CAL and the abbreviations file is named ABBREV.COD. You need only remember the first part of each name, that is, DAILY for the calendar file and ABBREV for the abbreviations file. (The portion to the right of the period is called an extension, and allows PERTMASTER to identify the type of file.)

Your computer screen should still show PERTMASTER's Main Menu. Since you want to create a new plan, type *1* to **Produce an Up-to-Date Plan**. After a short delay, the menu shown on the next page will appear.

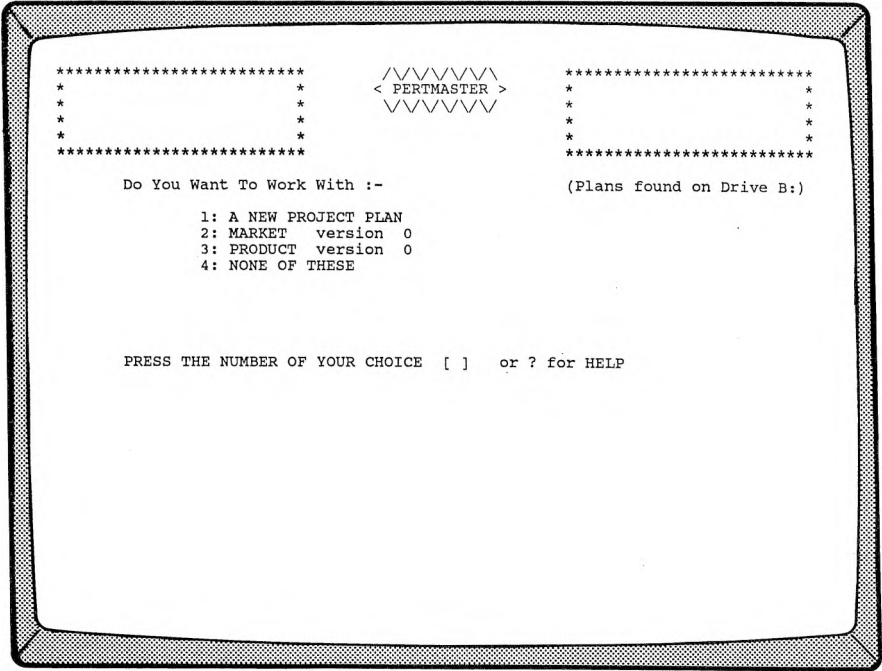

This is a list of all of the plans on your disk. We have supplied two sample plans, MARKET and PRODUCT, at least one of which you will use later. In the meantime, you want to create a new plan, so type *1* to select **A NEW PROJECT PLAN**. After another short delay, a new menu will be displayed.

Please Enter The Following Information :-

Plan File Identification (1 to 8 Letters): []
Left Hand Report Title (Upto 30 Letters):
Centre Report Title (Upto 30 Letters):
Right Hand Report Title (Upto 30 Letters):
Calendar Code-Name (1 to 8 Letters):
Abbreviations Code-Name (1 to 8 Letters):
Plan Format Type (A=Arrow, P=Precedence):
Time Units per Day (Numeric,Upto 3 digits):

NOTE: Press RETURN only to skip Item, or to Leave it Unchanged
Press ESCAPE to Back Up One Steo, or ? for HELP

Here is where you enter all of the information which will allow PERTMASTER to recognize your plan and to print out the titles that you want to appear on reports.

Initially, the cursor on your terminal will be positioned at the bracket to the right of the first item, **Plan File Identification**. This is the name you want to use to identify your plan. The name you choose cannot exceed eight characters, must start with a letter, may not contain a space, and otherwise contain only letters or numbers. Let's call this plan *WIDGET*, so type the word *WIDGET* and press ◀RETURN▶.

The cursor will move to the next line, **Left Hand Report Title**. Here, and at the next two lines, you can enter any descriptive titles that you wish to appear on report. For this example, type *XYZ Products, Inc.* and press ◀RETURN▶.

For the **Centre Report Title** (this program was written in Great Britain!), type *SUPER-WIDGET* and press ◀RETURN▶. Then type *Menlo Park, CA* for the **Right Hand Report Title** and again press ◀RETURN▶.

The cursor will now be at the **Calendar Code-Name** line. Remember that we told you that PERTMASTER needed a calendar to be used in each plan, that we supplied a sample calendar file called DAILY.CAL, and that you needed only to know the first part of the file name. Therefore, type **DAILY** to enter the calendar code-name, and press **<RETURN>**.

Similarly, the abbreviations file supplied on your disk is named ABBREV.COD. So you should type **ABBREV** to enter the **Abbreviations Code-Name**, followed by **<RETURN>**.

Next you must enter the **Plan Format Type**. Since you are working with an Precedence plan, type **P**.

The last line, **Time Units per Day**, will already have the number **1** entered. You want your plan to be executed in single-day units, so simply press **<RETURN>** to leave this line unchanged. Your screen should now look like this.

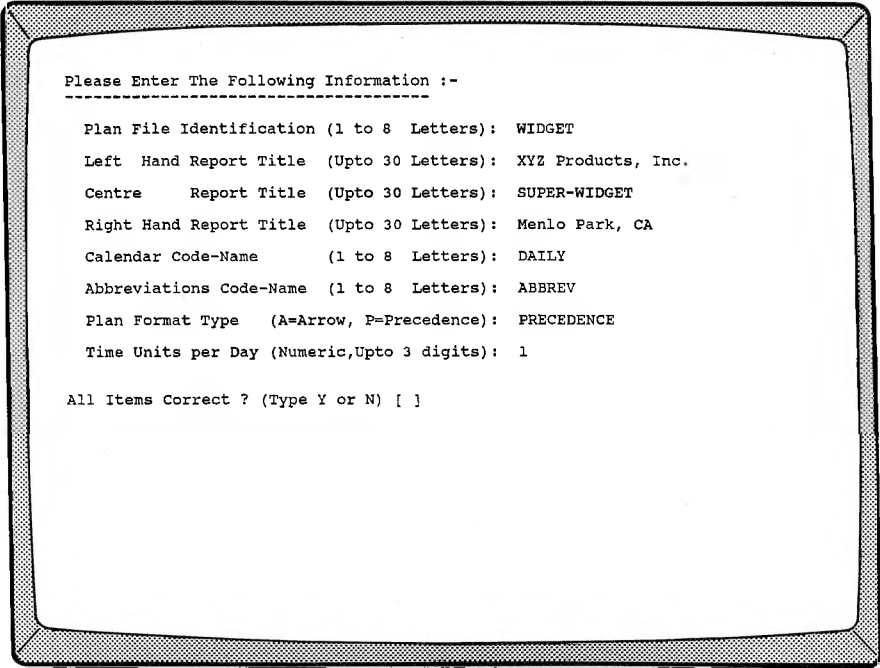

Now PERTMASTER will ask

All Items Correct ?

At this time, check your entries very carefully. If there is a mistake on any of the lines, type *N* (No), and you will be returned to the top of the menu. Press ◀RETURN▶ until the cursor is at the incorrect line. Then type over the incorrect entry (you can use the space bar to delete unwanted characters) and press ◀RETURN▶ again until you reach the bottom of the list. When all of the entries are correct, type *Y* (Yes).

Entering Plan Activities in PERTMASTER

As soon as you tell PERTMASTER that all of your preliminary entries are correct, the following screen will appear.

```
Enter New Activities :-                Current Plan: WIDGET  version 0
LINE  FROM  TO  DURATION  DESCRIPTION                ?=HELP
1 :   [    ]
```

The plan name and version number are shown at the top right corner. Since this is a new plan, the version number is **0**.

The column under the word **LINE** will show a line number for each line that you enter in your plan, will start at **1** for a new plan, and will

increment by one each time you type a line. (After 19 lines, a new screen display is initiated, starting over again at line 1.) You do not type the line numbers; they appear automatically. Now let's start entering the data for the activities on our paper plan.

NOTE: If you make a mistake while typing, and the cursor has not moved to the succeeding line, press ◀**ESCAPE**▶. This will "erase" the entire line, allowing you to retype it.

If you notice a mistake in a line which you have already typed, just make a note of it. We'll tell you how to correct it when you have finished entering your plan.

Every plan must have a start and a finish, so type *S* and press ◀**RETURN**▶. PERTMASTER will immediately display the first line of the plan, showing that activity 1 is a start and is also a milestone. The cursor will be in the **TO** column on line 2, awaiting your entry of a link to the beginning of your plan. PERTMASTER will also display the message

Activity exists - New links only

which tells you that it has reserved activity 1 for the start and that the start must be linked to an activity in the plan.

Since activity 2 is the first activity on the plan, type 2 and press ◀**RETURN**▶. The cursor will immediately move to the **DESCRIPTION** column, where PERTMASTER will ask

SCHEDULED (Y/N)

Type *N* (No) to indicate that you have not scheduled a starting date. The cursor will now be on line 3.

Although activities do not have to be entered in any specific order, PERTMASTER works faster if they follow an orderly sequence. Let's continue with activity 2. In the **FROM** column, type 2 to specify the activity, then press ◀**RETURN**▶.

The cursor will move to the **DURATION** column. Since the duration of activity 2 is 4 days, type 4 and press ◀**RETURN**▶. The cursor will then be in the **DESCRIPTION** column; type *Approve Product Design*, the description of activity 2, and press ◀**RETURN**▶. The cursor will move to the next line.

NOTE: To save typing time and computer memory, abbreviations are normally entered in place of full descriptions. We will discuss the use of abbreviations in Chapter 8.

Now you must enter the links from activity 2 to its succeeding activities. Since the link starts from the preceding activity, initiate the link by

pressing ◀RETURN▶ when the cursor is in the **FROM** column. The cursor will move to the **TO** column with the symbol → designating a link. The first link is to activity 4, so type 4 in the **TO** column, followed by a ◀RETURN▶.

The cursor will move to the **DURATION** column. According to our plan, this link has no duration, so again press ◀RETURN▶ to move the cursor to the **DESCRIPTION** column, where PERTMASTER will display the message

LINK TYPE ? = HELP

At this point you must enter the type of link which, you may recall, can be finish-to-start, start-to-start, or finish-to-finish. PERTMASTER allows you to enter the link type in either of two abbreviated ways. To see the abbreviations, type a ? (question mark). You will see the following display.

1 = F-S 2 = S-S 3 = F-F

This tells you that if you type either a 1 or FS, you will have entered a Finish-to-Start link. Similarly, if you type 3 or FF, you will have entered a Finish-to-Finish link. A Start-to-Start link is entered by typing 2 or simply S. (Two letters are not needed, since there is only one link type that starts with S.)

The link type from activity 2 to 4 is a finish-to-start, so type either 1 or FS. The cursor will move to the **FROM** column on the next line.

Press ◀RETURN▶ to initiate another link, then type 3 to show the link to activity 3, and press ◀RETURN▶. Again the duration is zero, so again press ◀RETURN▶. And again the link is finish-to-start, so again type either 1 or FS.

Enter the links from activity 2 to activities 6 and 7 in exactly the same manner.

Now enter the data for activity 4. Remember to press ◀RETURN▶ after each entry. Type 4 in the **FROM** column, 6 in the **DURATION** column, and *Prepare Sales Documents* in the **DESCRIPTION** column.

To enter the link from activity 4 to activity 3, press ◀RETURN▶ when the cursor is in the **FROM** column and type 3 in the **TO** column. The link has a duration of one day, so type 1 when the cursor is under **DURATION**. Note that this is a finish-to-finish link, since it goes from the right side of activity 4 to the right side of activity 3. Therefore, type 3 or FF to designate its type in the **DESCRIPTION** column.

Now that you know how to do it, enter activities 3, 6, 7, and 20, following each activity with the link which originates at that activity. Don't forget to

enter a duration of 5 for the link from activity 7 to activity 20. Then all that remains is to indicate the finish.

To tell PERTMASTER that the plan is finished, initiate a link from activity 20 by pressing ◀RETURN▶ when the cursor is in the **FROM** column. Then type **F** in the **TO** column and press ◀RETURN▶ again. The word **FINISH** will appear in place of **F** and the cursor will move to the **DESCRIPTION** column. Again, PERTMASTER will ask

SCHEDULED (Y/N)

This time, type **Y** (Yes). You will then be asked to reply to

NOT AFTER DAY

which should be the day number by which the plan is to be completed. Normally, you would check your calendar file to determine the day number of the calendar date by which the plan is to be completed. Because we will not look at a calendar file until a later chapter, we will assume that the start of our plan will be on day 1.

WIDGET is a very simple plan, so it is easy to see that it must be finished in 44 days (4 days for activity 2, plus 25 days for activity 7, plus 5 days for the link from 7 to 20, plus 10 days for activity 20). Therefore, type **44** in response to PERTMASTER's query, and press ◀RETURN▶.

The cursor will move to the next line. Since your plan is finished, press ◀ESCAPE▶. PERTMASTER will then display the entire plan, which should look like this.

```

COMMAND? [      ]           Current Plan: WIDGET   version 0
LINE  FROM   TO   DURATION  DESCRIPTION           ?=HELP
1 :    1     <->MILESTONE      START
2 :    1     --> 2             UNSCHEDULED
3 :    2     4             4             Approve Product Design
4 :    2     --> 7             0             FINISH->START
5 :    2     --> 6             0             FINISH->START
6 :    2     --> 3             0             FINISH->START
7 :    2     --> 4             0             FINISH->START
8 :    3     10            10            Train Sales Force
9 :    3     --> 20            0             FINISH->START
10:    4     6             6             Prepare Sales Documents
11:    4     --> 3             1             FINISH->FINISH
12:    6     15            15            Appoint Distributors
13:    6     --> 20            0             FINISH->START
14:    7     25            25            Produce First Units
15:    7     --> 20            0             FINISH->START
16:    20    10            10            Product Launch
17:    20    --> FINISH        NOT AFTER DAY 44
18:    500  <->MILESTONE      FINISH

```

You can see that the plan has been rearranged in order of the activity numbers. In addition, an activity will have been added to indicate that the finish is a milestone. This activity number will be **500, 1000, 1500, or 2500**, depending on the computer that you are using. It indicates the maximum number of activities and links which may be used in a plan. (If you are using the PERTMASTER Demo disk, you will be limited to a total of 50 activities and links.)

Check the plan very carefully for errors, especially typing mistakes, and note the incorrect line(s).

Press ESCAPE and PERTMASTER will ask you to

Enter a New Time Day Now Number

with the number 1 already entered. Because this is a new plan, PERTMASTER assumes that it is being created as of day 1 of the plan. This being so, press ◀RETURN▶ instead of retyping the number 1. The next menu shown in this chapter will appear.

CORRECTING YOUR PLAN

If you did not make any mistakes in typing the entries for your plan, you can skip this part and proceed directly to the paragraph titled "GETTING A SCREEN REPORT." However, if you are like most of us, you will have made a typing error. If so, you can correct it as follows.

Type **2** to **Save the Plan and Continue Updating**. Your plan will again be displayed on the screen.

If the error is in the **DURATION** or **DESCRIPTION** column, type the **LINE** number which is to be changed and press **◀RETURN▶**. The cursor will move to the **DURATION** entry. If the entry is correct, simply press **◀RETURN▶** to move to the next column. Correct either entry by typing over the existing data (you can use the space bar to delete unwanted characters), and press **◀RETURN▶**. When the cursor moves to the next line, press **◀ESCAPE▶**.

To correct any other error, you must delete the existing line and type a new one. To do this, type **D** followed by the **LINE** number which is to be changed (e.g. type **D7** to delete line 7), and press **◀RETURN▶**. The cursor will move to that line, where you again press **◀RETURN▶**. PERTMASTER will redisplay the plan with the line deleted.

Now type **I** to insert a new line. A new screen display will allow you to completely reenter the corrected line, just as if you were entering the line in a new plan. When the cursor moves to the next line, press **◀ESCAPE▶**.

As soon as you press **◀ESCAPE▶**, the corrected plan will be displayed. Again press **◀ESCAPE▶** and then press **◀RETURN▶** as the response to

Enter a New Time Day Now Number.

GETTING A SCREEN REPORT

```
*****
*                               *
* Current Plan :WIDGET          *
* Status       :NEW            *
*                               *
*****

                               < PERTMASTER >
                               /V/V/V/V/V/V/V\
                               \V/V/V/V/V/V/V/

*****
*                               *
* Version : 0                   *
* Size    : 8                   *
*                               *
*****

Do You Want To :-

1: Save the Plan and Get Some Reports ?
2: Save the Plan and Continue Updating ?
3: Save The Plan and Start Again ?
4: Remove Some Old Plans from the Disk ?
5: Abandon This Plan and Start Again ?

PRESS THE NUMBER OF YOUR CHOICE [ ] or ? for HELP
```

Immediately after you specify the **Time Day Now Number**, the menu shown above will be displayed.

The plan name and status (**NEW**) appear in the top left corner, and the version number and size appear in the top right corner. Size is the number of activities in the plan; the start and finish each are counted as an activity

We want to see some reports, so type **1** to select the first option on the menu.

NOTE: If PERTMASTER has been supplied to you on more than one disk, it will display the message

**Please Insert Disk 2 In the Default Drive
Press RETURN when this has been done.**

The Default Drive is the disk drive in which the lowest numbered disk was placed when you started using the program.

The first report to look at is the **Screen Report**, so type **6** to choose that one. The following menu will appear.

```
*****
*                               *
* Current Plan :WIDGET         *
* Status       :SAVED         *
*                               *
*****
< PERTMASTER >
*****
* Version : 0                 *
* Size    : 8                 *
*                               *
*****

Do You Want This Report to Have :-

1 : The Earliest Activities First ?
2 : The Output in Alphabetical Sequence ?
3 : The Most Critical Activities First ?

PRESS THE NUMBER OF YOUR CHOICE [ ] or ? for HELP
```

Type *I* to see a barchart which will show **The Earliest Activities First**. Then the Screen Report Selective Reporting Menu will be displayed.

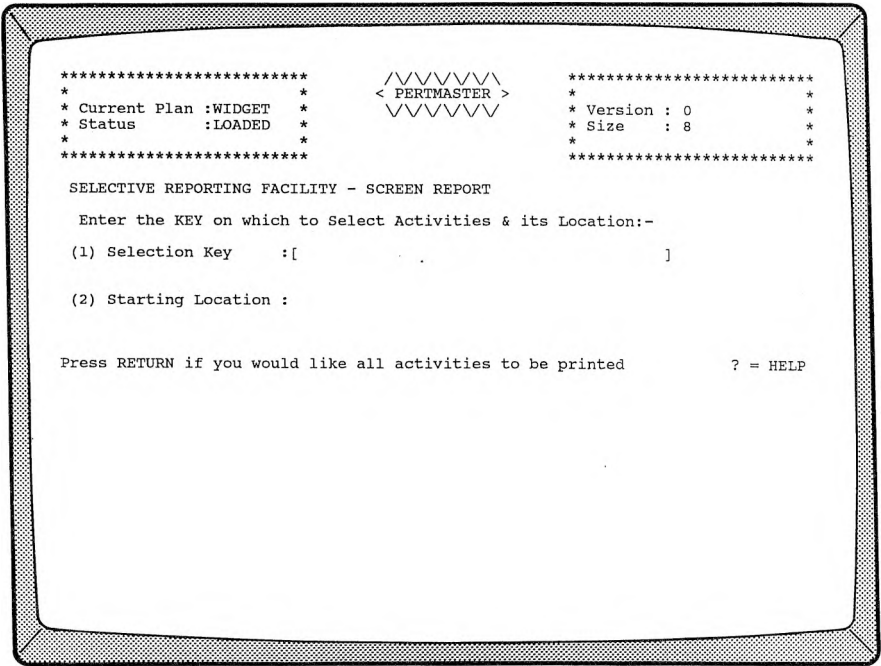

This menu allows you to limit the activities which will show up on the report. Since you are working with a very small plan, simply press **◀RETURN▶** to have all of the activities printed on the report. At that time, the Report Menu will reappear with **SCREEN REPORT** listed under **Reports Ordered So Far**:

To see this report before asking for printed reports, select the option **Start or Cancel the Run** by typing **8**. PERTMASTER will then tell you to

PRESS RETURN TO START THE RUN, ESC TO CANCEL

Since you want to see the report, press **◀RETURN▶** and PERTMASTER will display a barchart which looks similar to the one of those shown below and on the next page.

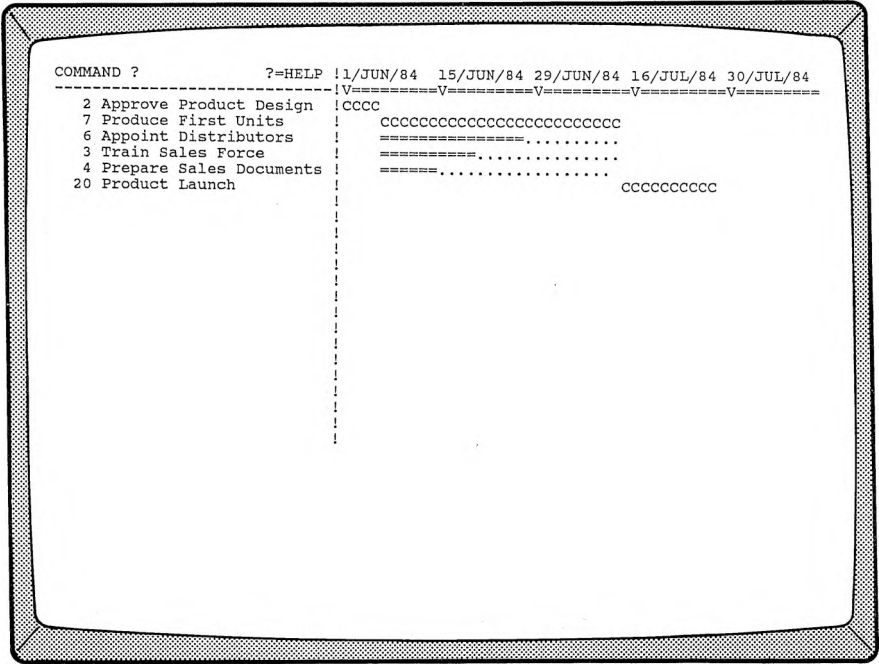

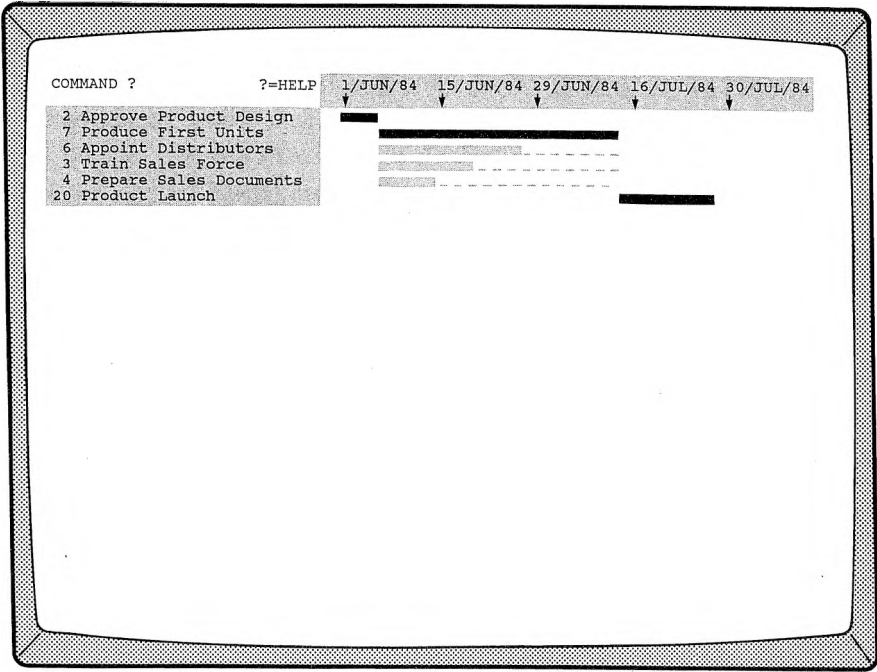

We previously told PERTMASTER to start the report at day 1, which turns out to be 1 June 1984 because that is the first working day in our calendar file (DAILY.CAL). Also, the number of days between the dates along the top of the report are working days; the calendar file allows you to specify working and non-working days.

The report also shows that the activities **Prepare Sales Documents**, **Train Sales Force**, and **Appoint Distributors** have float, indicated by the dots or underscores which trail the bar for each activity. This means that any of those activities could be delayed, up to the date at which the float ends, without delaying the finish of the plan.

To leave the Screen Barchart and get some printed reports, press ◀**ESCAPE**▶. PERTMASTER will then ask you to

Please press Y if you want more reports
Press N if you do NOT

Type **Y** (Yes) to return to the Report Menu.

GETTING SOME PRINTED REPORTS

We will now print out two reports on your printer. **BE SURE THAT THE PRINTER IS TURNED ON AND IS "ON LINE"** before you continue. If it is not "on line," or if you don't have a printer connected to your computer, the computer will "hang up" and you will have to reset it.

The first report which we will print is the **Standard Report Listing**, which you select by typing *1*. The Sort Option Menu, which appeared when you asked for a Screen Report, will reappear. Again choose option *1* to have the report list **The Earliest Activities First**.

Next, the Selective Reporting Menu will be displayed. As with the Screen Report, we want to show all activities, so just press **◀RETURN▶**. The Report Menu will reappear, with **STANDARD REPORT** listed under **Reports Ordered So Far**.

PERTMASTER allows you to print out a maximum of ten reports at once, so you can keep on selecting reports. Since you have already seen the Screen Barchart, pick option *2* to get printed **Project or Period Barcharts**. Again, the menu will appear which will allow you to choose the order in which the activities will appear. This time, type *3* to see **The Most Critical Activities First**.

Again, a Selective Reporting Menu will be shown. And again, press **◀RETURN▶** so that all activities show on the report. A new display, the Barchart Report Menu, will now appear.

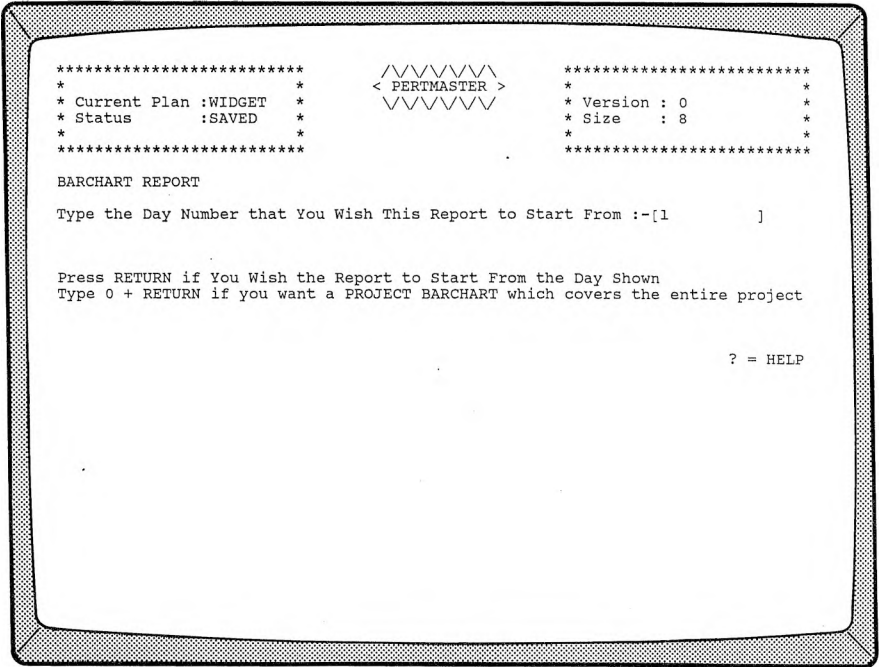

In order to see a Period Barchart which starts at day 1, again press **<RETURN>**. Once more, the Report Menu will appear, this time with **PERIOD BARCHART** also listed under **Reports Ordered So Far**:

To print out both of the reports ordered so far, type **8** and press **<RETURN>**. BE SURE THAT YOUR PRINTER IS ON! The Standard Report will be printed first, followed immediately by the Period Barchart. PERTMASTER will then ask you to

Please press Y if you want more reports
Press N if you do NOT

Type **N** and you will be returned to the Main Menu.

NOTE: If you had to change disks when you started asking for reports, PERTMASTER will instruct you to

Please Insert Disk 1 In the Default Drive
Press RETURN when this has been done.

before returning to the Main Menu.

Let's look at the Standard Report Listing. Yours should look the the one below.

| XYZ Products, Inc. REPORT TYPE :STANDARD LISTING | | SUPER-WIDGET | | Menlo Park, CA. | | | |
|---|----------------|---|--------------|-----------------|----------|-------|--|
| PLAN I.D. :WIDGET VERSION 0 | | PRINTING SEQUENCE : Earliest Activities First | | | | | |
| | | SELECTION CRITERIA:ALL | | | | | |
| | | TIME NOW DATE :1/JUN/84 | | | | | |
| ACTIVITY DESCRIPTION | EARLIEST START | EARLIEST FINISH | LATEST START | LATEST FINISH | DURATION | FLOAT | |
| 2 Approve Product Design | 1/JUN/84 | 6/JUN/84 | 1/JUN/84 | 6/JUN/84 | 4 | 0 * | |
| 7 Produce First Units | 7/JUN/84 | 12/JUL/84 | 7/JUL/84 | 12/JUL/84 | 25 | 0 * | |
| 6 Appoint Distributors | 7/JUN/84 | 27/JUN/84 | 21/JUN/84 | 12/JUL/84 | 15 | 10 | |
| 3 Train Sales Force | 7/JUN/84 | 20/JUN/84 | 28/JUN/84 | 12/JUL/84 | 10 | 15 | |
| 4 Prepare Sales Documents | 7/JUN/84 | 14/JUN/84 | 3/JUL/84 | 11/JUN/84 | 6 | 10 | |
| 20 Product Launch | 13/JUL/84 | 26/JUL/84 | 13/JUL/84 | 26/JUL/84 | 10 | 0 * | |

All of the plan activities are listed, with the earliest and latest start and finish dates. Each of the critical activities — **Approve Product Design**, **Produce First Units**, and **Product Launch** — is marked with an asterisk in the **FLOAT** column and shows no difference between its earliest and latest dates, since it has zero float. The other activities have float. This report tells you the latest date that each might be started without affecting the end date of the project.

The Period Barchart should look similar to the following.

| XYZ Products, Inc. REPORT TYPE :PERIOD BARCHART | | SUPER-WIDGET | | Menlo Park, CA. | | | | | | | | | | | |
|--|------|--|-------|-----------------|-------|-------|------|------|------|-----|-----|-----|-----|-----|----|
| PLAN I.D. :WIDGET VERSION 0 | | PRINTING SEQUENCE : Most Critical Activities First | | | | | | | | | | | | | |
| | | SELECTION CRITERIA:ALL | | | | | | | | | | | | | |
| | | TIME NOW DATE :1/JUN/84 | | | | | | | | | | | | | |
| PERIOD COMMENCING DATE | 1984 | 11 | 111 | 118 | 125 | 12 | 19 | 116 | 123 | 130 | 16 | 113 | 120 | 127 | 13 |
| MONTH | 1JUN | ! | ! | ! | ! | ! | ! | ! | ! | ! | ! | ! | ! | ! | ! |
| PERIOD COMMENCING TIME UNIT | 11 | 17 | 112 | 117 | 122 | 126 | 131 | 136 | 141 | 146 | 151 | 156 | 161 | 166 | ! |
| 2 Approve Product Design | ! | CCCC | ! | ! | ! | ! | ! | ! | ! | ! | ! | ! | ! | ! | ! |
| 7 Produce First Units | ! | CCCCCCCC | CCCC | CCCC | CCCC | CCCC | CCCC | ! | ! | ! | ! | ! | ! | ! | ! |
| 20 Product Launch | ! | ! | ! | ! | ! | ! | ! | CCCC | CCCC | ! | ! | ! | ! | ! | ! |
| 6 Appoint Distributors | ! | ===== | ===== | | | | ! | ! | ! | ! | ! | ! | ! | ! | ! |
| 3 Train Sales Force | ! | ===== | ===== | | | | ! | ! | ! | ! | ! | ! | ! | ! | ! |
| 4 Prepare Sales Documents | ! | ===== | | | | | ! | ! | ! | ! | ! | ! | ! | ! | ! |

Barchart Key:- CCC :Critical Activities ===== :Non Critical Activities HNN :Activity with Neg Float ... :Float

On this report, the critical activities are shown first because that's what we told PERTMASTER to do. The bars for critical activities are printed using a series of **C**'s. The bars for the non-critical activities consist of equal signs, with float shown as dots. Float is interpreted exactly the same as on the Screen Barchart.

Also, day 1 is shown as 1 June 1984 because, as with the Screen Barchart, that is the first working day in our calendar file.

SUMMARY

Although you have been working with a simple plan, what you have learned is applicable to any Precedence Plan. You now know how to start a new plan, enter its activities and links, and get reports. Next, you will learn more about plans, as well as how to change a plan, which you will probably do much more often than creating a new one.

WHY CHANGES ARE MADE

In Chapter 7 you learned how to enter a new plan, albeit a very simple one. In all likelihood, you also used PERTMASTER's change capability to correct your errors, although you may not have realized that at the time. Since plans are dynamic — that is, they generally must change as time goes by, for any number of reasons — PERTMASTER provides a varied menu of change options. In this chapter, we are going to tell you how to make changes and will introduce you to some additional features which you will need when you create more complex plans.

In order to explain these features, we will use a plan which already exists on your PERTMASTER Data Disk. You will see that making changes is basically no different than entering a new plan; using the existing plan will save you the tedium of typing a more complicated new plan.

On the facing page we have shown the graphic network from which the computer plan was derived. By comparing the plan listing with this network, you will be able to see the exact correlation between the two.

Your first step is to call up PERTMASTER if you have not already done so. Then select option **1**, **Produce an Up-to-Date Plan**, from the Main Menu. From the list of plans that will then be displayed, enter the option number for **PRODUCT**, our sample Precedence Plan. The first nineteen lines of that plan will appear. If you had just entered the plan, you would have gotten the identical display immediately after you had pressed **◀ESCAPE▶** to signify the end of the plan.

To see the next nineteen lines, press **◀RETURN▶**. Notice that the line numbers are repeated, even though the plan activities have changed. Continue to press **◀RETURN▶** and the remaining activities will be shown.

HELP MENU

Before continuing, let's look at PERTMASTER's Help Menu. Do this by typing **?** (question mark). The following screen display will appear.

The COMMANDs Available are as Follows :-

- line - By entering a line number only, the duration, dates and/or the description of the activity on that line may be changed. The cursor will go to the items in turn, and you may enter a new value or just press RETURN to leave unchanged. When RESOURCES are selected another change can be made to the next line.
- I - INSERT will allow you to enter details of more activities. The screen will clear and you should enter your new activities.
- H - HEADINGS will allow changes to the Plan heading details.
- RES - RESOURCES will cause the display of any resource details. You can then change or enter them using the line command.
- DES - DESCRIPTIONS will return you back to the normal display.
- Dline - DELETE allows the line entered to be removed. The cursor will jump to the line, press RETURN to delete or ESCAPE to cancel. You could type D12 to delete line 12 for example.
- RETURN- By pressing return only, the next 19 lines will be displayed.
- Gx - Goto will cause the 19 lines starting at the node/activity x to be displayed.
- ESCAPE- Pressing this key will end this section. You will be asked to enter a new time now value, and then you may save this version.

Press any Key to Continue

These are the commands which will enable you to make changes to a plan, once it has been entered. You will make extensive use of them as you use PERTMASTER, and eventually will remember most of them. Until then, you can always type a question mark to refresh your memory.

At this time, some of the commands may appear to be cryptic, because of space limitations of the screen. However, as you go through the procedures in this chapter (and in some of the subsequent ones), the commands will become quite clear. You have already used the **RETURN** command to see the lines on the plan which were not displayed initially.

Now let's go back to the beginning of the plan. Press any key to erase the Help Menu. You will again see the last part of the plan displayed. The cursor will be at the **COMMAND** line at the top of the screen, indicating that PERTMASTER is awaiting your command.

To go to any point in the plan, the **Gx** command is used. "G" means "go to" and the "x" signifies the activity number. However, if you want to go to the beginning of the plan, you can always use a zero in place of the

actual number. Therefore, type **GO** and press **◀RETURN▶**; PERTMASTER will once more display the first nineteen lines of the plan.

| COMMAND? [] | | Current Plan: PRODUCT version 0 | | |
|-----------------|------|---------------------------------|-----------|----------------------------------|
| LINE | FROM | TO | DURATION | DESCRIPTION |
| 1 : | 1 | <> | MILESTONE | START |
| 2 : | | --> | 2 | UNSCHEDULED |
| 3 : | | --> | 3 | UNSCHEDULED |
| 4 : | | --> | 4 | UNSCHEDULED |
| 5 : | 2 | | 6 | GM Create !PR Business Plan |
| 6 : | | --> | 7 | 0 FINISH->START |
| 7 : | 3 | | 4 | GM Develop !PR Marketing Plan |
| 8 : | | --> | 5 | 0 FINISH->START |
| 9 : | 4 | | 3 | GM Develop !PR Design Concepts |
| 10 : | | --> | 6 | 0 FINISH->START |
| 11 : | 5 | | 3 | GM Negotiate License Agreement |
| 12 : | | --> | 7 | 0 FINISH->START |
| 13 : | 6 | | 3 | GM Develop Production Plan |
| 14 : | | --> | 7 | 0 FINISH->START |
| 15 : | 7 | | 2 | GM Approve !PR Plans & Design |
| 16 : | | --> | 9 | 0 FINISH->START |
| 17 : | 9 | | 3 | GM create and Approve !PR Budget |
| 18 : | | --> | 10 | 0 FINISH->START |
| 19 : | 10 | | 3 | GM Appoint !PR Manager |

CHANGING DURATIONS OF ACTIVITIES AND LINKS

Probably the changes that you will make most often will be in the durations of activities. You will normally reduce durations as the work progresses. You may have to increase the duration of an activity because you have changed the estimate of time that an activity will take.

Let's assume that activity **5, Negotiate License Agreement**, in the **PRODUCT** plan will take two more days than originally planned. (For the time being, we will ignore the two-letter codes which precede the descriptions.) Therefore, the duration of the activity must be changed to five days. To enter this in the plan, type the **LINE** number to be changed, in this case **11**, and press **◀RETURN▶**. The cursor will move to the **DURATION** column. Type **5**, the new duration, and press **◀RETURN▶**.

The cursor will then move to the **DESCRIPTION** column, where you could type in a new description if you wanted to do so. Since we are changing

only the duration, press ◀RETURN▶ again, and the cursor will return to the command line, leaving the description unchanged.

Refer to the plan drawing and note that the duration of each path between the start and activity 5 is six days. By changing the duration of activity 5, you have increased the duration of one path to eight days. Therefore, you can expect this to affect your schedule. Although the effect of the change is obvious in this particular plan, it might not be so in another. Nonetheless, PERTMASTER will recalculate the schedule when you save the changed plan.

The duration of a link may also be changed in exactly the same way. The type of link can be changed by typing the new link code when the cursor is in the **DESCRIPTION** column.

DELETING AND ADDING ACTIVITIES AND LINKS

Activities are often added or deleted as a project progresses and more data become available. We can use our sample plan to demonstrate how this is accomplished.

First, type **G23** in order to display activity 23 and succeeding eighteen lines. Then, as an example, suppose that activity 24 is to be split into two separate activities, so that samples can be obtained before the orders are placed. To do this, the original activity must be deleted so that two new ones can take its place. (We went to line 23 instead of line 24 to let you see that there is a link from 23 to 24 and one from 24 to 29.)

To delete the activity, use the **D** (Delete) command, followed by the **LINE** number of the activity to be deleted. Since activity 24 is now on line 6, type **D6**, and press ◀RETURN▶. The cursor will move to that line, giving you the opportunity of changing your mind. If you press ◀ESCAPE▶, the delete command will be cancelled. To delete the line, which we have decided to do, press ◀RETURN▶.

When an activity is deleted, **ALL CONNECTING LINKS ARE ALSO DELETED**. (However, you may delete a link on its own.) Thus, when the plan is redisplayed, you can see that links 23-24 and 24-29 have been removed along with activity 24.

Now you must insert two new activities, which we will designate 24, MD Order Sample Binders and Cases, and 42, MD Order Production Binders and Cases. Note that we will maintain a path from activity 23 to activity 29, but will insert a new activity between them.

Type **I**, which is PERTMASTER's Insert command, and press ◀RETURN▶. The resulting display is the same one used to enter a new

plan. However, you need only type the activities which you are adding. As with entering a new plan, type *24* in the **FROM** column, use a duration of *10* in the **DURATION** column, and type *MD Order Sample Binders and Cases* as the description. Press ◀RETURN▶ after each entry.

When the cursor is on the next line, enter a finish-to-start link from *24* to *42*. Press ◀RETURN▶ to indicate it is a link from the previous activity, and type *42* in the **TO** column. Then either enter a duration of *0* or press ◀RETURN▶, and designate the link as a finish-to-start by typing *FS* or *I* in the **DESCRIPTION** column.

Similarly, enter activity *42* on the next line, using a duration of *20* and *MD Order Production Binders and Cases* as its description. On the succeeding line, enter a finish-to-start link to activity *29*, also with zero duration.

Let's not forget about the deleted link between activities *23* and *24*. You must replace it with a new finish-to-start link from *23* to *24*. Therefore on the next line, type *23* in the **FROM** column to initiate the link. When you press ◀RETURN▶, PERTMASTER will immediately inform you that

Activity exists - New links only

and will display the activity with its existing links. The cursor will be positioned in the **TO** column. Type *24* to designate the succeeding activity. Again enter a duration of zero and a finish-to-start description.

When the cursor moves to the next line, press ◀ESCAPE▶ to indicate that there are no more changes to be made. The plan listing will reappear, with the new lines properly sequenced.

ADDING MILESTONES

Although we did not incorporate them in the new plan that you entered in Chapter 7, every plan should include milestones. Milestones are key dates within a project. They are selected to provide certain management levels with overall, rather than detailed, information. The number of milestones used in a typical plan should normally be between five and ten percent of the number of activities.

If you refer to the plan listing for **PRODUCT**, you will see several milestones listed. We are going to add one more at delivery of the production quantity of binders and cases, our new activity *42*.

In a Precedence Plan, milestones are considered activities having no duration, since they are key dates only. They must have links to other activities in the plan. Although milestones should normally be entered when a plan is formulated, they can always be added to an existing plan.

We want a milestone, which we will arbitrarily designate activity 43, indicated at the completion of activity 42. However, 42 is linked to 29, and all we want to do is call attention to this point in time by inserting the milestone. Nevertheless, the link from 42 to 29 must be deleted so that the milestone can be inserted, and new links added to and from the milestone.

Add milestone 43 by again using the **I** command, since it is being inserted. Then, on the first line of the ensuing display, type **43**, and press **◀RETURN▶**. When the cursor moves to the **TO** column, simply type **M** and a **◀RETURN▶**. The word **MILESTONE** will appear, and the cursor will move to the **DESCRIPTION** column, because a milestone has no duration.

At this point, type a suitable description, such as **READY FOR ASSEMBLY**, and press **◀RETURN▶**. After the cursor moves to the next line, press **◀RETURN▶** to initiate the link to activity 29. Enter this as a finish-to-start link with zero duration. Exit the insert display, as before, by pressing **◀ESCAPE▶**. When the plan is redisplayed, it will include the added milestone.

As a final step, you must now delete link 42-29, using the same procedure as when you were entering the added activities, 24 and 42.

Milestones are generally used to signify the completion of a major portion of a plan, but can be used anywhere that you consider applicable.

ADDING STARTS AND FINISHES

As you learned in Chapter 7, every plan must have at least one start and at least one finish. They may be scheduled or unscheduled, and may be changed. Once a project is underway, an unscheduled start should be scheduled.

Adding extra starts or finishes to your project is the way in which network analysis allows you to place time constraints on your work. By using scheduled starts you can make any activity start on or after a certain date. By using scheduled finishes you can force any activity to finish by a fixed date. Thus a combination of scheduled starts and scheduled finishes will allow you to achieve any form of time constraint that you want, including specifying that an activity must happen on a specific date.

In our sample plan, both the start and finish are unscheduled. At this time, we will assume that our project has started and that we want to change to a scheduled start.

If you are not at the beginning of the plan, type **G0**, then press **◀RETURN▶**, to go there. In our plan, there are links from the start,

which is the seventh working day of the calendar. Therefore, type 7 and press ◀RETURN▶. The plan will now read **NOT BEFORE DAY 7** for the start.

Change the other two links in exactly the same manner, so that activities 2, 3, and 4 are all scheduled to start on day 7 or later.

If you want to change the start day again, repeat the procedure and type the new day number over the old one in the brackets. If you want to change from a scheduled start to an unscheduled one, type a zero when the cursor is at the brackets. PERTMASTER will change the start to unscheduled.

Finishes are changed in nearly the same way. The only differences between the two are that the links **TO** the finish are changed, and the statement in the **DESCRIPTION** column reads **NOT AFTER DAY []**.

CHANGING PLAN HEADINGS

When you first entered a new plan, you had to provide PERTMASTER with certain information about the plan — its name, the type of plan, calendar and abbreviations file names, time units per day, and report titles. Although it is not likely that you will ever want to change any of these but possibly the last two, all of them can be changed except for the plan type. You cannot change from a Precedence to an Arrow Plan, or vice versa, without reentering your data in the format dictated by the other type of plan.

To change any of the other details, type *H* when the cursor is at the command line, and press ◀RETURN▶. PERTMASTER will then display the New Plan Menu with all of the entries for the plan shown.

As explained on the screen, you can move the cursor down or up by using the ◀RETURN▶ and ◀ESCAPE▶ keys. You can then change any of the entries, except for the **Plan Format Type**, by typing over the existing words and using the space bar to eliminate any characters at the end. If you try to change the type of plan, PERTMASTER will reject the entry.

Should you elect to change the **Plan File Identification** and save the plan, it will become version **0** under the new name. However, the prior version under the old name will still be retained on your Data Disk.

Exiting this part of the change routine is done in exactly the same way as for a new plan, and returns you to the plan listing.

SAVING OR ABANDONING CHANGES

When you are finished making changes and the cursor is at the command line, press **◀ESCAPE▶** to tell PERTMASTER that there are no more changes. You will then be asked to

Enter a New Time Day Now Number

This would normally be the day number in the calendar file on which you are making the changes. PERTMASTER will always display **1** if there has been no previous change. Under the assumption that these changes are being made on day 7, type 7 and press **◀RETURN▶**.

The Change/Abandon Plans Menu, which you saw in Chapter 7, will be displayed. We don't really want to save the changes that were made, so select option **5, Abandon This Plan and Start Again**. PERTMASTER will warn you that

PRODUCT version 1 Is About to be Lost Do You Want To Continue ? (Type Y or N)

Respond by typing **Y** and you will be returned to the Main Menu.

USING ABBREVIATIONS

Up to now, you have not used any abbreviations in entering a new plan or in changing the sample plan. Nonetheless, the use of abbreviations, especially in long plans, is extremely important in that there is a considerable savings in the amount of memory which will be used.

If you displayed the New Plan Menu, as described above under Changing Plan Headings, you will have seen that the **PRODUCT** plan uses an abbreviations file named **ABBREV**. Also, as shown in the plan listing shown earlier in this chapter, several descriptions contain entries like **!PR** and **!SS**. These are **PERTMASTER**'s short-hand entries for the abbreviations in abbreviations file **ABBREV**, shown below.

```

PERTMASTER
-----
SCHEDULE OF ABBREVIATIONS AND DESCRIPTIONS STORED ON DISK UNDER THE HEADING : ABBREV
-----
1  PE - Executive Staff
2  PM - Product Manager
3  PS - Sales Staff
4  PO - Support Staff
5  SD - Database Software
6  PC - Consultants
7  SP - Personnel Cost in Dollars
8  #S - Shipping Material Cost in $100s
9  #C - Consulting Cost in Dollars
10 #M - Product Material Cost in $100s
11 EC - Computer
12 ES - Contracted Equipment
13 MB - Binders and Cases in Hundreds
14 MI - Manual Inserts in Hundreds
15 MP - Product Materials in Hundreds
16 MM - Packaged Manuals in Hundreds
17 MS - Shipping Materials in Hundreds
18 MF - Product ready to ship in Hundreds
19 SP - PagePlanner Software
20 SM - Pertmaster Software
21 RM - Conference Room
22 #T - Contract Cost in $100s
23 SL - Sales Literature
24 UM - Users manual
25 AD - Advertising
26 PR - Product
27 SS - Sales Staff
  
```

Note that the majority of the entries consist of a two-letter abbreviation, followed by the description, or definition, of the abbreviation. (A few entries use a \$ or # sign as the first character; these will be explained in Chapter 9.)

To save both computer memory and typing time, you should use abbreviations wherever possible. They are entered in the descriptions of activities by preceding the two letters with an exclamation mark, and will appear on the plan listing as such. However, the full description will appear on all of the reports which **PERTMASTER** generates.

Thus, the description for activity 18, which reads **MS Hire !SS**, will be printed as "MS Hire Sales Staff," since "SS" is the abbreviation for "Sales Staff."

The two-letter codes without the leading exclamation mark, which appear in the **PRODUCT** plan descriptions, are not abbreviations as defined by **PERTMASTER**. They have been included to aid in the selection of reports, and will be discussed in Chapter 10.

Whenever you initiate a new plan, you will normally need to create a new abbreviations file or add to an existing file. Complete instructions for doing either appear in Reference Section 5.2. Setting up a dummy abbreviations file, applicable to small plans which may not require abbreviations, will be found in Chapter 11.

SUMMARY

We have now covered all of the basics that you need to know about entering and changing Precedence Plans. However, we still have not discussed one of PERTMASTER's strongest points — resource tracking. While you do not have to use or track resources in your plans, doing so will increase the usefulness of those plans. Chapter 9 explains resource tracking.

Of course, the whole purpose of PERTMASTER is to provide you with meaningful and useful reports. These are covered in detail in Chapter 10. You should proceed directly to that chapter if you do not want to use resource tracking at this time.

RESOURCE TRACKING FACILITY

PERTMASTER's resource tracking facility is designed to calculate the total resource requirements for your projects, based on your estimate of resources required for each activity. It is worth spending some time learning the resource tracking facility thoroughly, if you feel that this feature could be useful to your work. It is powerful, and like many powerful tools, it is necessary to take a some care in its use.

PERTMASTER does not require you to make use of the resource tracking facility. If you only wish to calculate the time that events will occur, you do not need to enter the resource requirements.

The resource tracking facility is available on both Arrow and Precedence Networks. The facility is used in exactly the same way on both types of plans; therefore this chapter is applicable to both.

PURPOSE AND USES OF RESOURCE TRACKING

PERTMASTER allows you to define your resources as you wish. A resource can be labor or machines or money or materiel. There are few limits to what you can do with resources. For example, a class of resources might be tons of concrete, the percentage of a key employee's time, miles of pipework, or costs in thousands of dollars. The units and the description of the resources are entirely under your control. PERTMASTER will simply sum all the resources of a particular class in order to provide you with an answer.

PERTMASTER uses two-letter abbreviations both for activity descriptions and for resource codes. These are stored in the abbreviations file set up for a plan. During its calculations, PERTMASTER uses the resource code, but prints a full description of the resource on the reports. See Reference Section 5.2 for a full description of abbreviations.

Before using resources on a plan, you should consider carefully exactly which resources you wish to use. PERTMASTER will handle up to 29 different resources. However, if you are using paper in your printer that is only 132 characters wide, then you will only be able to see the first 23 resource categories reported. Normally this is sufficient. You should aim to use the resource tracking facility for the most important resources on your project, not for every nut and bolt. For example, consider including:

Labor: particular classes of skills which are important, or could limit the speed at which the job can be done.

Machines: major items such as cranes, assembly lines, etc.

Material: major items, especially items which require special or continuous delivery, or have long lead times on order.

Money: major cost categories.

Remember that PERTMASTER is not intended to be a cost control or materials management system. The resources that should be included are simply those which are likely to have an effect on the time schedule that you are establishing.

TYPES OF RESOURCES

PERTMASTER allows the use of three different types of resources to reflect the way in which resources are handled in the real world. These are:

1. Conventional resources, using any two letters for abbreviations. These will produce histogram reports, and are generally intended for non-expendable resources. Non-expendable resources are those which you expect have on hand at the end of the project, such as the labor force and machines used in a project.

You can use any two letters for any resource code. However, you can take advantage of the PERTMASTER system if you choose your resource codes carefully. In the following examples, the codes are mnemonic — the abbreviation reminds you of the full description.

LA for laborers

BK for bricklayers

CC for cubic yards of concrete

2. Expendable resources, which use “\$” followed by a letter of the alphabet. These resources will produce cash-flow or S-curve reports. This type of report is best used on resources which are expendable, and which you do not expect to have left over at the end of the project, such as materials and money. Typical codes might be:

\$D for cost in dollars

\$H for foreman’s time in hours

3. Point resources, which use “#” followed by a letter of the alphabet. These resources are generally expendable and will also produce a histogram. This type of resource is not one which is assumed to be spread evenly over the whole activity, but instead will be completely exhausted on the last day of the activity. A point resource is often used for payments, which are frequently made to or by a contractor when a certain stage in a project is complete. Codes for point resources are shown in the following examples:

#B for payment in dollars

#K for gallons of kerosene

HANDLING LARGE NUMBERS

When resources are entered in a plan, the two-character code is followed by a number which denotes the quantity of the resource used in each time period of an activity. Using one of the preceding examples, you would enter *LA5* to indicate that five laborers are required. If the activity has a duration of four days, the five laborers would be needed each of the four days. Similarly, “*\$D250*” would indicate that the cost expended per day in that activity is estimated at \$250.00.

If one or more of your resources involves large numbers, such as “*D\$74000*,” PERTMASTER may not be able to fit the long numbers involved into the scales of the cash-flow reports. This is likely to cause untidy printouts. Therefore, instead of using “*D\$74000*,” use “*D\$74*” and define “*D\$*” in your abbreviations file as “Cost in Thousands of Dollars.”

Using this technique, your reports will be just as accurate and much neater. This point generally applies to the cash element of a plan, but is equally applicable to all resources where large quantities are involved.

USING MULTIPLE RESOURCES ON ONE REPORT

PERTMASTER allows the use of multiple resources on one report. Although this chapter does not cover reports specifically, this feature is mentioned here, as it can affect your choice of abbreviations for your resources.

For example, asking for a report on resource *A=* will generate a report on the sum of resources which have the letter “*A*” as the first letter of the resource. The second letter may be any letter. In computing terms, the equal sign is used as a “wildcard.”

An appropriate example of the use of this facility would be to total different costs. If you used “*\$M*” for material costs, “*\$L*” for labor costs,

and “\$O” for overhead, then a report on “\$=” would provide a report on the total of these costs.

INCORPORATING RESOURCES IN A PLAN

Resources are incorporated in a plan by means of the change commands, which were discussed in Chapter 6 for Arrow Plans, and in Chapter 8 for Precedence plans. In each of those chapters, you may have noticed that two of the commands were not covered. Because they applied only to resources, we postponed covering them until now.

We will revert to the sample plans on the Data Disk to illustrate how resources are entered. Call up PERTMASTER and select option *I* on the Main Menu. Then, if you have been using Arrow Plans, choose **MARKET** from the next menu. If you have been working with Precedence Plans, choose **PRODUCT**.

When your plan appears, type *RES*, which is the RESource command, and press **◀RETURN▶**. The display will change to a list of the plan’s activities and the **RESOURCES ALLOCATED PER UNIT TIME** for each activity, as shown in the following displays.

| COMMAND? [] | | | Current Plan: MARKET version 0 | |
|-----------------|------|-------|---|--------|
| LINE | FROM | TO | RESOURCES ALLOCATED PER UNIT TIME | ?=HELP |
| 1 : | 1 | -> 2 | PE2 PO1 EC4 SM4 \$P460 | |
| 2 : | | -> 3 | PE2 PO1 EC4 SM4 \$P460 | |
| 3 : | | -> 4 | PE2 PO1 EC4 SM4 \$P460 | |
| 4 : | 2 | -> 4 | PE2 PO1 EC2 SM2 \$P460 | |
| 5 : | 3 | -> 4 | PE1 PO1 EC1 SM1 \$P260 | |
| 6 : | 4 | -> 5 | PE4 PO1 EC2 SM2 \$P860 | |
| 7 : | 5 | -> 6 | PE1 PO2 EC2 SM2 SD2 \$P320 | |
| 8 : | 6 | -> 7 | PE2 PO1 EC1 SM1 SD1 \$P460 | |
| 9 : | 7 | -> 8 | PM1 PO2 EC2 SM1 SD2 \$P310 | |
| 10 : | | -> 9 | PM1 PE1 PO2 PC1 EC1 \$P510 #C800 | |
| 11 : | | -> 10 | PM1 PO1 EC1 SM1 SD1 \$P260 | |
| 12 : | | -> 25 | PM1 PS5 PO1 EC2 SM2 SD2 \$P700 | |
| 13 : | 8 | -> 12 | PM1 PO8 EC5 SM1 SD5 ES4 MP300 \$P750 #S4 | |
| 14 : | 9 | -> 11 | PM1 PE1 PC1 EC1 SM1 \$P390 #C200 | |
| 15 : | 10 | -> 25 | PM1 PC1 PS5 PO4 EC5 ES1 RM1 \$P880 #C600 | |
| 16 : | 11 | -> 14 | PO1 EC1 SD1 \$P60 | |
| 17 : | | -> 15 | PO2 PC2 EC1 SM1 \$P460 #C1300 | |
| 18 : | 12 | -> 13 | PO8 EC5 SD5 ES4 MF250 MS250 \$P560 #M1200 | |
| 19 : | 13 | -> 27 | PO2 EC2 SD2 MF5 \$P120 | |

COMMAND? []

Current Plan: PRODUCT version 0

| LINE | FROM | TO | RESOURCES ALLOCATED PER UNIT TIME | ?=HELP |
|------|------|----|---|--------|
| 1 : | 2 | | PE2 PO1 EC4 SM4 \$P460 | |
| 2 : | 3 | | PE2 PO1 EC4 SM4 \$P460 | |
| 3 : | 4 | | PE2 PO1 EC4 SM4 \$P460 | |
| 4 : | 5 | | PE1 PO1 EC1 SM1 \$P260 | |
| 5 : | 6 | | PE2 PO1 EC2 SM2 \$P460 | |
| 6 : | 7 | | PE4 PO1 EC2 SM2 \$P860 | |
| 7 : | 9 | | PE1 PO2 EC2 SM2 SD2 \$P320 | |
| 8 : | 10 | | PE2 PO1 EC1 SM1 \$P460 | |
| 9 : | 12 | | PM1 PC1 P04 PS5 SD1 SM1 ES1 RM1 \$P1040 | |
| 10 : | 15 | | PM1 PC2 PS5 PE2 PO3 RM1 \$P1220 \$C1000 | |
| 11 : | 17 | | PS5 PO1 EC7 SD7 \$P570 | |
| 12 : | 18 | | PM1 PS5 PO1 EC2 SM2 SD2 \$P700 | |
| 13 : | 19 | | PM1 PE1 PO2 PC1 EC1 \$P510 #C800 | |
| 14 : | 20 | | PM1 PE1 PC1 EC1 SM1 \$P390 #C200 | |
| 15 : | 21 | | PO2 PC2 EC1 SM1 \$P460 #C1300 | |
| 16 : | 22 | | PO1 EC1 SD1 \$P60 | |
| 17 : | 23 | | PE3 PM1 PO1 \$P650#C200 | |
| 18 : | 24 | | PO1 EC1 SD1 SM1 \$P60 #T250 | |
| 19 : | 25 | | PO2 PC3 EC4 SP4 \$P120 #T160 | |

You can return to the *DE*scription listing by typing *DES*. If you scroll the screen, and then redisplay the resources by again typing *RES*, the resources may be on another line, but they will be on your screen. *PERTMASTER* always displays the resources allocated to the activities which were shown on the preceding description listing.

The resource codes are listed in ABBREV, the abbreviations file that is used by both plans, and which is reproduced below.

| PERTMASTER | | | |
|--|-------------------------------------|----|--|
| SCHEDULE OF ABBREVIATIONS AND DESCRIPTIONS STORED ON DISK UNDER THE HEADING : ABBREV | | | |
| 1 | PE - Executive Staff | 2 | PM - Product Manager |
| 3 | PS - Sales Staff | 4 | PO - Support Staff |
| 5 | SD - Database Software | 6 | PC - Consultants |
| 7 | SP - Personnel Cost in Dollars | 8 | FS - Shipping Material Cost in \$100s |
| 9 | FC - Consulting Cost in Dollars | 10 | FM - Product Material Cost in \$100s |
| 11 | EC - Computer | 12 | ES - Contracted Equipment |
| 13 | MB - Binders and Cases in Hundreds | 14 | MI - Manual Inserts in Hundreds |
| 15 | MP - Product Materials in Hundreds | 16 | MM - Packaged Manuals in Hundreds |
| 17 | MS - Shipping Materials in Hundreds | 18 | MF - Product ready to ship in Hundreds |
| 19 | SP - PagePlanner Software | 20 | SM - Pertmaster Software |
| 21 | RM - Conference Room | 22 | FT - Contract Cost in \$100s |
| 23 | SL - Sales Literature | 24 | MW - Users manual |
| 25 | AD - Advertising | 26 | PR - Product |
| 27 | SS - Sales Staff | | |

The first resource code, **PM**, is the product manager. Therefore, **PM1** indicates that one product manager is assigned to that activity for each time unit in the activity's duration. In our plans, a time unit has been specified as one day. Similarly, **EC1** means that one computer per day has been allocated to the activity.

An expendable resource, **\$P**, has been allocated to the activity. **\$P510** tells PERTMASTER that the daily personnel cost is 510 dollars. It could also be 510 pounds sterling, if you defined it that way; the "\$" sign indicates the type of resource, not the monetary unit.

The last resource, **#C800**, is a point resource for consulting costs in dollars. Therefore, when the activity is complete, the total consulting cost for the three days of the activity will be \$2,400.00.

ENTERING AND CHANGING RESOURCES

Resources are entered or changed in exactly the same way as you would change an activity or a link. All of the commands used to change plans can be used to change or enter resources, with one exception — a resource line cannot be deleted. A resource line exists for every activity in your plan, whether or not you allocate resources to the activity or to the entire plan.

You can use the **Gx** command to go to any point in the resource listing.

◀**RETURN**▶ will display the next nineteen lines of resources. However, if you use the **DES** command and then change the display of activities, the resources that are shown when you again use the **RES** command will track the activities previously shown.

When resources are to be entered on a new plan, the resources screen will display all of the activity numbers, without any resources allocated, as you

would expect. Resources are then entered on a new plan, or changed on an existing plan in exactly the same way.

You use the “line” command to go to the line on which the resources are to be entered or changed. Then, either type in the new resources or type over the existing ones. As with changing plans, pressing ◀RETURN▶ signifies completion of the entry and moves the cursor to the following line. Pressing ◀ESCAPE▶ tells PERTMASTER that you are finished, and initiates the same exit routine as changing the basic plan.

The number of resources that may be allocated to an activity is limited by the space between the brackets on the resources display. A space between resources has been used in the sample plans, and is recommended for the sake of clarity. However, leaving the space is not essential, so that it could be omitted if you had a large number of resources to enter against an activity.

PERTMASTER requires you to enter the resources as the amount that you will use over a period of unit time. For example, if an activity takes four days, and you enter the resource of five laborers against it, then PERTMASTER knows that you want to use those five laborers for each of the four days that the activity is in progress.

This is a convenient concept. Remember that the duration used on an activity is actually the duration that remains to complete the activity. If you reduce the remaining duration to reflect work already done, then the reduced resource requirement is automatically taken into account. Thus, if the activity used in the above example now takes only two days to complete, you simply change the duration to two days; the resource requirement for five laborers will be altered by PERTMASTER to five laborers over two days only.

If you want to see the empty resources listing for a new plan, “escape” from the update section, remembering to abandon the plan you have been viewing. Then, tell PERTMASTER to update the plan which you used back in either Chapter 5 (LAUNCH plan) or Chapter 7 (WIDGET plan). When you ultimately display the resources screen, by following the procedures which you have just learned, all of the plan’s activity numbers will be displayed, devoid of resources.

As an exercise, you can enter resources in this plan, using the resource codes in the ABBREV file. Since you will have no further use for either LAUNCH or WIDGET, except as a practice plan, feel free to make any changes whatsoever.

GETTING REPORTS ON RESOURCES

Reports on resources may be just as valuable to you as the reports of events that PERTMASTER produces. Both screen and printed reports are available, and are described in detail in Chapter 10.

ANALYSIS

While you are entering a plan, altering a plan, or saving it on disk, PERTMASTER performs no calculations on your plan. However, before you can get a printed report, all the correct activity dates and resource requirements for your plan must be calculated. This is done when your plan is analyzed by PERTMASTER.

The analysis is not something that you, as a user of PERTMASTER, need be concerned about. In this chapter you will see that you simply select reports from a list, and then ask PERTMASTER to produce those reports. If PERTMASTER has to analyze the plan, which is usually the case, the plan will be analyzed. It is important that you know that this happens, as PERTMASTER will detect logical errors in your plan at this stage.

If your plan is to be analyzed, a message that the analysis section is being loaded will be printed on screen. PERTMASTER will then analyze the plan in two stages.

First, PERTMASTER will execute a forward pass. This means that PERTMASTER begins at the start(s) of a plan, and adds up the durations of all the activities in the plan, working towards the finish(es) of the plan. This forward pass will determine the critical path through your plan.

Second, PERTMASTER will execute a backward pass. This means that PERTMASTER starts at the finish(es) of your plan, and works back through all the activities to the start(s). This pass is used to determine the float available on each activity, and also takes the scheduled start dates of the activities into account.

As PERTMASTER works forward through the network, it will print the current duration (of an Arrow Plan) or the activity number (of a Precedence Plan) on the screen to illustrate the progress that it is making. This number will increase rapidly at first, but will settle down as it approaches the end of the plan. If the plan is not developing as you would expect, you can issue a cancel instruction by pressing **◀ESCAPE▶**.

During the backward pass, the duration or activity numbers will also be shown on the screen. These numbers will probably exceed those of the forward pass, because the start dates have been included.

GETTING REPORTS

There are two routes by which you can reach PERTMASTER's report section. If you are at the Main Menu, choose option 2 to **Get Reports From an Up-to-Date Plan**. PERTMASTER will then present you with a list of the plans on your Data Disk. If there are more plans on the disk than can be displayed on the list, the last option on the list will read **OTHER PLANS ON THIS DRIVE**. The remaining plans will be listed if you choose this option.

At this time, select the option number next to **MARKET version 0** (an Arrow Plan) or **PRODUCT version 0** (a Precedence plan), whichever you have been using up to now.

If you have just been working with a plan, choose option 1 on the Save/Abandon Plan Menu, which will allow you to **Save the Plan and Get Some Reports**.

NOTE: When PERTMASTER has been supplied to you on more than one disk, it will display the message

**Please Insert Disk 2 In the Default Drive
Press RETURN when this has been done.**

The Default Drive is the disk drive in which the lowest numbered disk was placed when you started using the program.

is a problem in the plan, PERTMASTER will not be able to complete its analysis and will display an error message.

By selecting the Screen Report, you actually can produce three different reports on the screen. Furthermore, many of the options associated with the Screen Report are applicable to reports which are printed out on a printer. Therefore, it is an excellent starting point for learning about PERTMASTER's reports.

When you type 6 to choose the Screen Report, the following menu will appear and allow you to select the order in which the activities in your plan will be shown.

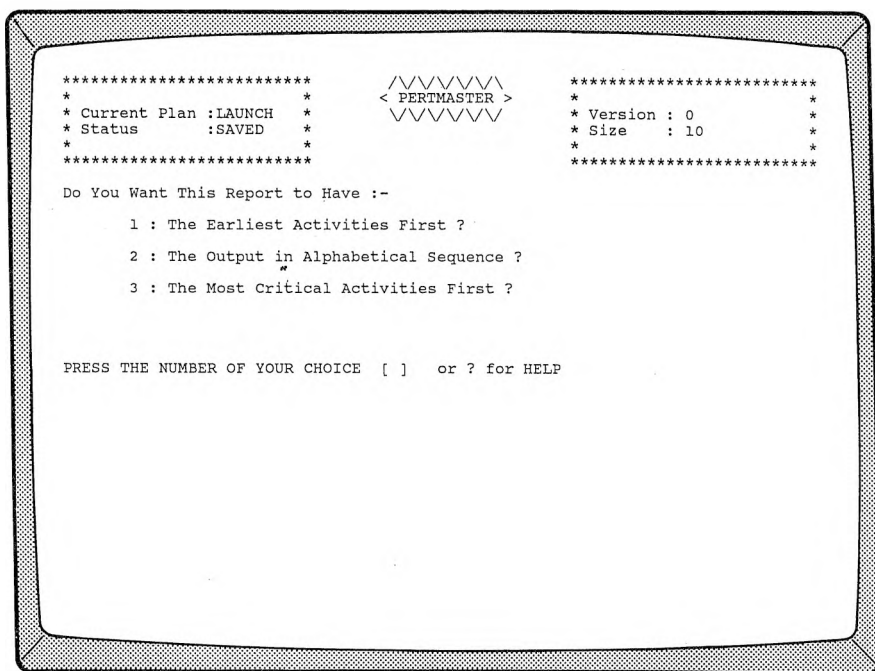

Selecting option 1 will result in reports on which the activities appear in chronological order. The most critical activities (those on the critical path) will appear at the beginning of the reports if option 3 is selected. Either of these options takes you to a Selective Reporting Menu immediately.

On the other hand, option 2 intersperses an additional menu which you should see to be fully aware of PERTMASTER's capabilities. When you type 2, the following menu will be displayed.

```
*****
*                               *
* Current Plan :PRODUCT *      <  \/\\/\\/\  >
* Status       :SAVED  *      \/\\/\\/\  >
*                               *
*****                               *****
*                               *
* Version : 0 *
* Size   : 39 *
*                               *
*****                               *****

ALPHABETIC SORTING - SCREEN REPORT

Enter the part of the Description to be Sorted Alphabetically:-

(1) Starting Location   :[ ]

(2) Number of Characters :

Press RETURN to Sort on the Whole Description           ? = HELP
```

The **Starting Location** entry will specify the character position of the activity description on which the sort is to be made. The **Number of Characters** will indicate the number of characters following the starting location that are to be sorted. If you press **◀RETURN▶** instead of entering a **Starting Location**, a sort will be made on the entire description.

For the present, let's sort on the entire description, so simply press **◀RETURN▶**. The following Selective Reporting Menu will appear. This is the same menu which would have been shown had you chosen to list the activities in chronological order or to list the most critical activities first.

```
*****
*                               *
*      < PERTMASTER >         *
*                               *
* Current Plan :LAUNCH *      * Version : 0 *
* Status      :SAVED *      * Size   : 10 *
*                               *
*****
SELECTIVE REPORTING FACILITY - SCREEN REPORT

Enter the KEY on which to Select Activities & its Location:-

(1) Selection Key      :[           ]

(2) Starting Location :

Press RETURN if you would like all activities to be printed      ? = HELP
```

The **Selection Key** is a character or group of characters which allows you to print out only selected activities. The **Starting Location** is the position in the description at which the Selection Key starts. These features will be discussed later in the chapter. At this time, we want all activities to appear in the report, so just press **◀RETURN▶**.

The Report Menu will be redisplayed with **SCREEN REPORT** listed under **Reports Ordered So Far**. To print the Screen Report, type 8 and then press **◀RETURN▶** to start the run. PERTMASTER will execute its forward and backward passes, and print out a Screen Barchart on your terminal.

The Screen Barchart which is now displayed may or may not have been customized, for your computer. If it has been customized, it will be similar to the following, in which critical activities are identified by a highlighted (bright) bar, non-critical activities by a normal bar, and float by a dashed line. If there were an activity with negative float, it would be shown as a flashing, highlighted bar.

COMMAND ?

?=HELP

1/JUN/84

15/JUN/84

29/JUN/84

16/JUL/84

30/JUL/84

2 GM Create IPR Business Pla
3 GM Develop IPR Marketing P
4 GM Develop IPR Design Conc
5 GM Negotiate License Agree
6 GM Develop Production Plan
7 GM Approve IPR Plans & Des
8 GM create and Approve IPR
10 GM Appoint IPR Manager
12 MS Hire & Train ISS
15 MS Sales Conference
17 MS Sell and Process Orders
18 MS Appoint Distributor
19 MD Design IPR Package
20 MD Approve IPR Package
21 MD Design IMN
22 MD Select Binder and Case
23 MB Approve IMN Design
24 MD Order Binders and Cases
25 MD Write IMN
26 IMN Layout Mockup
27 MB IMN Artwork and Photogr
28 MD Print IMN



If your computer does not use a customized version of PERTMASTER, the Screen Barchart will look like the one shown below.

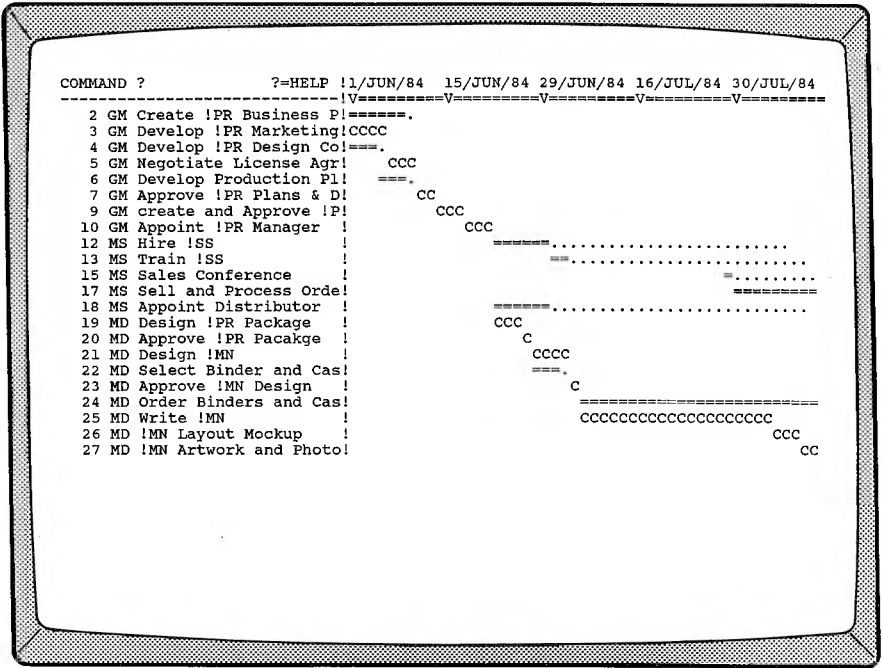

In this case, critical activities are designated by a series of C's (**CCCCCC**), non-critical activities by a row of equal signs (=====), and float by a string of periods (.....). If there were an activity with negative float, it would be shown as a series of N's (**NNNNNNN**).

The display that you are looking at shows only the first nineteen activities. To find out how to see the remaining activities, call up the Screen Report Help Menu by typing ?.

The COMMANDS available are as follows :-

Rght arrow- Scrolls the window to the right.
Lft arrow- Scrolls the window to the left.
Down arrow- Moves the window down 18 lines.
Up arrow- Moves the window up 18 lines.

B - Type this command to switch back to a barchart display.
R - Type this to select a histogram for the period shown,
you should enter a resource code if no resource is selected.
L - Type this to select a normal date list for the activities.
C - Use this command to change to a different resource code.
N - This command will allow you to select a new start day number
Enter the number or +/- x to go x days in either direction.
G - This will allow you to goto another section of the plan by
typing the first part of the description of the activity
that you wish to have listed at the top of the page.
Start with a single quote for a key search.
ESC - Type escape to leave the program.

Press any key to continue

NOTE: If you are using a customized version of PERTMASTER, and your computer has function keys, the functions that PERTMASTER has assigned to these keys will be shown at the bottom of your screen. However, in this chapter we will use the commands which are defined on the help menu, rather than the function keys, because we don't know what type of computer you are using.

Depending on the type of computer that is being used, the commands on the first four lines may be:

D or **Rght arrow**
S or **Lft arrow**
X or **Down arrow**
E or **Up arrow**.

Scrolling the window to the right sets an earlier starting date for the report, if possible. Conversely, scrolling the window to the left results in a later

starting date. The up and down commands are used to view succeeding and preceding activities, eighteen lines at a time.

Now press any key; the Barchart Key, which was explained above, will appear. To return to the Screen Barchart, again press any key. Use the up and down commands to view the remaining activities, and use the left and right commands to change the starting date of the report. Then return to the Screen Report Help Menu by again typing ?.

The Screen Barchart can be converted into a Screen List, which will show the actual dates by which activities must be started and finished. The L-command is used for this. First, exit the help menu by pressing ◀RETURN▶ twice. The Screen Barchart is always displayed when you leave the help menu.

When the cursor is at the command line at the top of the screen, type L. The Screen List provides exactly the same information as the Screen Barchart, but in a form which makes it easier to read exact start and finish dates.

| COMMAND ? | ?=HELP | EARLY START | LATE START | LATE FINISH | DUR | FLOAT |
|-------------------------------|--------|-------------|------------|-------------|-----|-------|
| 2 GM Create !PR Business Pla | | 1/JUN/84 | 4/JUN/84 | 11/JUN/84 | 6 | 1 |
| 3 GM Develop !PR Marketing P | | 1/JUN/84 | 1/JUN/84 | 6/JUN/84 | 4 | 0 |
| 4 GM Develop !PR Design Conc | | 1/JUN/84 | 4/JUN/84 | 6/JUN/84 | 3 | 1 |
| 5 GM Negotiate License Agree | | 7/JUN/84 | 7/JUN/84 | 11/JUN/84 | 3 | 0 |
| 6 GM Develop Production Plan | | 6/JUN/84 | 7/JUN/84 | 11/JUN/84 | 3 | 1 |
| 7 GM Approve !PR Plans & Des | | 12/JUN/84 | 12/JUN/84 | 13/JUN/84 | 2 | 0 |
| 9 GM create and Approve !PR | | 14/JUN/84 | 14/JUN/84 | 18/JUN/84 | 3 | 0 |
| 10 GM Appoint !PR Manager | | 19/JUN/84 | 19/JUN/84 | 21/JUN/84 | 3 | 0 |
| 12 MS Hire & Train !SS | | 22/JUN/84 | 1/AUG/84 | 8/AUG/84 | 6 | 27 |
| 15 MS Sales Conference | | 27/JUL/84 | 9/AUG/84 | 9/AUG/84 | 1 | 9 |
| 17 MS Sell and Process Orders | | 30/JUL/84 | 10/AUG/84 | 30/AUG/84 | 15 | 9 |
| 18 MS Appoint Distributor | | 22/JUN/84 | 1/AUG/84 | 8/AUG/84 | 6 | 27 |
| 19 MD Design !PR Package | | 22/JUN/84 | 22/JUN/84 | 26/JUN/84 | 3 | 0 |
| 20 MD Approve !PR Pacakge | | 27/JUN/84 | 27/JUN/84 | 27/JUN/84 | 1 | 0 |
| 21 MD Design !MN | | 28/JUN/84 | 28/JUN/84 | 3/JUL/84 | 4 | 0 |
| 22 MD Select Binder and Case | | 28/JUN/84 | 29/JUN/84 | 3/JUL/84 | 3 | 1 |
| 23 MD Approve !MN Design | | 5/JUL/84 | 5/JUL/84 | 5/JUL/84 | 1 | 0 |
| 24 MD Order Binders and Cases | | 6/JUL/84 | 17/JUL/84 | 27/AUG/84 | 30 | 7 |
| 25 MD Write !MN | | 6/JUL/84 | 6/JUL/84 | 2/AUG/84 | 20 | 0 |
| 26!MN Layout Mockup | | 3/AUG/84 | 3/AUG/84 | 7/AUG/84 | 3 | 0 |
| 27 MD !MN Artwork and Photogr | | 8/AUG/84 | 8/AUG/84 | 13/AUG/84 | 4 | 0 |
| 28 MD Print !MN | | 14/AUG/84 | 14/AUG/84 | 27/AUG/84 | 10 | 0 |

The Screen List can be scrolled vertically to show all activities. You can redisplay the Screen Barchart at any time by typing **B**.

The last of the Screen Reports is the Screen Histogram, which is a histogram of any conventional resource used in your plan. (Expendable and point resources cannot be displayed on a Screen Histogram.) For this report, type **R**. The command line will change to

Enter Resource Code

at which point you enter the two-letter code used for the resource to be displayed.

One of the resource codes used in the abbreviations file shown in Chapters 6 and 8 is "EC", which stands for computer. To see how many computers are required by your plan, type **EC**, and press **◀RETURN▶**. A histogram similar to the one shown below will appear. The vertical bars will be solid if a customized version of PERTMASTER is being used; otherwise, they will consist of asterisks.

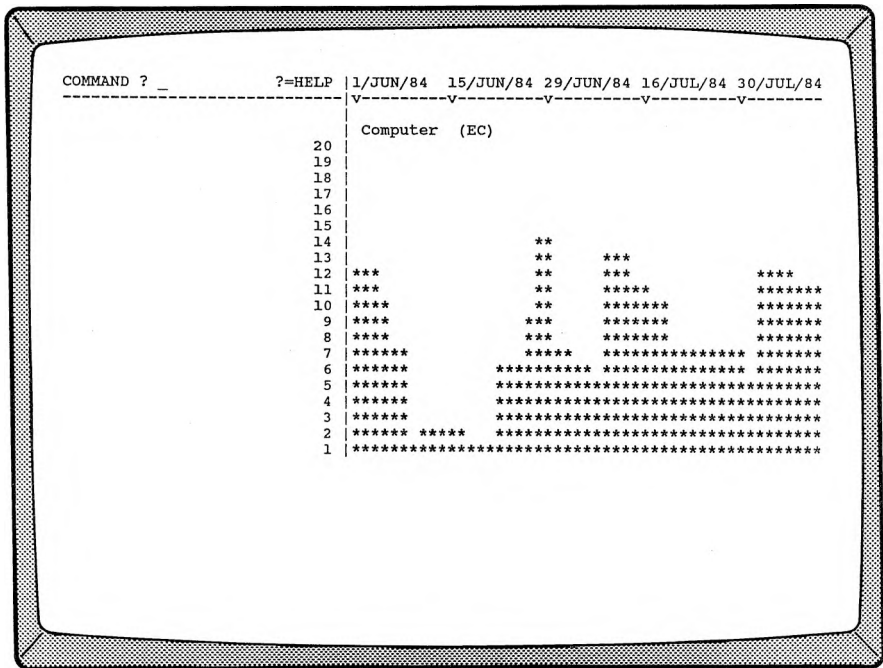

To change the histogram to another resource, type *C*. You can then enter the code for a new resource. If you press ◀RETURN▶, PERTMASTER will display the next resource listed in your abbreviations file.

The Screen Histogram can be scrolled both horizontally and vertically, in the same way as the Screen Barchart.

The last two Screen Report commands allow you to move about in the Screen Barchart and Screen Histogram. The *N*-command lets you enter a new start day number (not a calendar date) for the report. It can also be used to change the start by a specified number of days. For example, if you want to have the report start seven days later, enter +7; if you want the report to start five days earlier, type -5.

The *G*-command allows you to go to another section of your plan, so that the activity that you designate appears on the first line of your screen. When you type *G*, the command line will change to

Goto Activity ?

You may then type the first part of any activity description to move that activity to the top of the screen. Node or activity numbers (if shown) are considered as part of the description. If you wish to search for a key word in a description, prefix the word with an apostrophe (e.g. 'Roof'). PERTMASTER differentiates between upper- and lower-case letters; therefore, you must type any portion of the description that you use exactly as it appears in your plan.

When you enter a word or a portion of a word following the *G*-command, be sure that your entry uniquely identifies the activity that you want. For instance, "Del" would not be unique if the plan included the word "Deliver" and "Delete."

NOTE: If you type *G* and then simply press ◀RETURN▶, the start of your plan will be displayed.

To leave the Screen Report section, regardless of which report is on the screen, press ◀ESCAPE▶.

SELECTIVE REPORTING

The Selective Reporting Menu, which was mentioned briefly earlier in the chapter, is used in conjunction with several of the printed reports as well as the Screen Report. It allows you to print out selected activities, as determined by your entries in the following display.

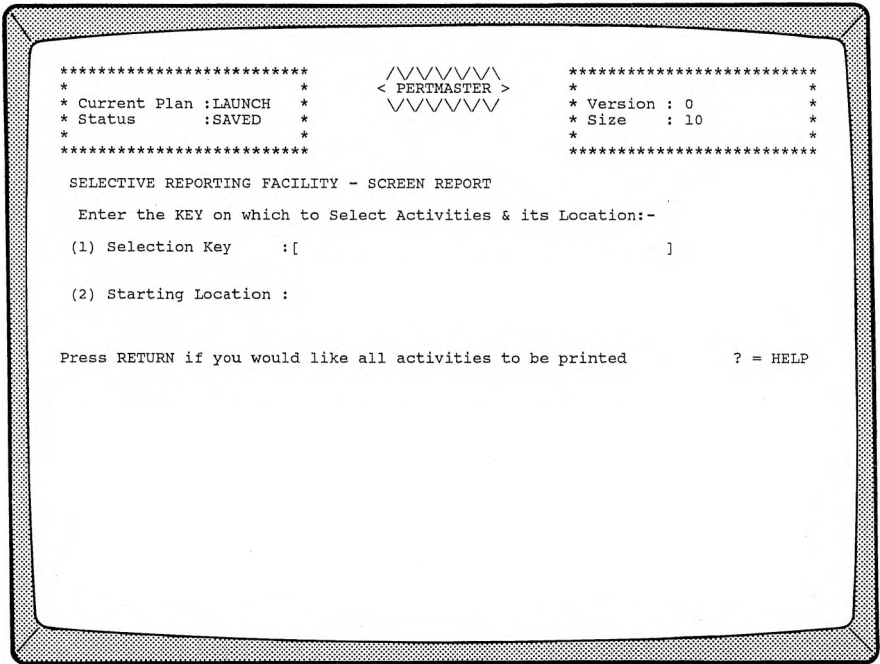

When this menu appeared previously, you pressed ◀RETURN▶ in order to have all activities shown on the Screen Report. However, suppose that you want to show only management activities. Return to the Report Section and proceed as before to get a Screen Report, but stop at the Selective Reporting Menu.

You may recall from Chapter 6 or Chapter 8 that the activities in the sample plan had two-letter codes (not abbreviations) at the beginning of each description. These were incorporated to allow us to demonstrate PERTMASTER's Selective Reporting Facility.

The codes which are used in the activity descriptions, and their definitions, are as follows:

- GM — General Management
- MA — Advertising
- MD — Documentation
- MP — Production
- MS — Sales

All of these codes appear at the beginning of the descriptions. Therefore, we can restrict the report to General Management activities by typing **GM** as the **Selection Key**, and typing **0** as the **Starting Location**, with a ◀RETURN▶ after each entry. Note that the first character in the activity description is designated location zero, and that you must enter the Selection Key in upper and/or lower case to match the activity description.

When you print out the Screen Report now, only those activities which have been coded as General Management activities will appear on the Screen Barchart and Screen List.

Selective Reporting may also be used to exclude activities above a specified float level. This is useful when you know that several activities have large floats, and you want to restrict the report to critical and near-critical activities.

To implement this selection, type **FLOAT**, in capital letters, as the **Selection Key**, and press ◀RETURN▶. PERTMASTER will then ask you to enter

Maximum Float

All activities whose float exceeds the number that you enter will be excluded from the reports.

PRINTED REPORTS

Requesting PERTMASTER's printed reports is considerably simpler than getting Screen Reports because there are no commands involved. All variations of the reports are covered in the help statements which will appear at the bottom of the screen when you type ?.

Whenever questions arise and you feel that the help statements do not provide the answer, all you need do is refer to Reference Section 4. Each report is discussed in detail.

A brief description of each of the printed reports appears at the end of this chapter. A sample report of each type is shown, with the features of each report highlighted.

DISK REPORTS

Disk Reports are used to transfer the data in your plan to other application programs, such as spread sheets and relational data bases. See Reference Section 4.6 and Appendix E for detailed information.

LIST OF ACTIVITIES & RELATIONSHIPS

The List of Activities & Relationships, option 3 on the Report Menu, is unique in that it uses an unanalyzed plan. When you have a printer connected to your computer, you should order this report first. It will allow you to determine that your plan is valid and that you have entered the data correctly.

A good use of this listing is to determine if your network logic is correct and up-to-date. You will see that each activity is listed together with its preceding and succeeding activities, and with its duration, description, and resources. Activities are separated from one another on the report by dividing lines.

For example, if any activity shows either that it has no preceding activity or no succeeding activity, you can see at once that your logic is incorrect. Plenty of white space has been left on this report for you to make notes of changes needed for your plan. We suggest that you use this listing as a worksheet when updating your plan.

When option 3 of the Report Menu is selected, the report will be identified as a **NETWORK LISTING** under **Reports Ordered So Far**, and as an **ACTIVITY LISTING** on the printed report.

The features of this report are shown on the following partial listings for Arrow and Precedence Plans.

ARROW PLAN ACTIVITY LISTING

| Westminster Software Inc. | | MARKETING A NEW PRODUCT | | | | Palo Alto CA 94304 | |
|---|------|-------------------------|------|---|--|--|---|
| REPORT TYPE : ARROW PLAN LISTING | | | | PRINTING SEQUENCE : Node/Activity Number Sequence | | SELECTION CRITERIA : ALL | |
| PLAN I.D. : MARKET VERSION 0 | | | | TIME NOW DATE : 1/JUN/84 | | | |
| DUR | PREC | SUCC | DUR | DESCRIPTION | RESOURCES | | |
| NODE | NODE | NODE | NODE | | | | |
| START -> 1 | | | | UNSCHEDULED | | | |
| >> 1 << MILESTONE START PRODUCT PLANNING | | | | | | | |
| START | => 1 | => 2 | 3 | GM Develop Product Design Concepts | 2 Executive Staff 4 Computer 460 Personnel Cost in Dollars | 1 Support Staff 4 Pertmaster Software | |
| | => 3 | 4 | | GM develop Product Marketing Plan | 2 Executive Staff 4 Computer 460 Personnel Cost in Dollars | 1 Support Staff 4 Pertmaster Software | |
| | => 4 | 6 | | GM Create Product Business Plan | 2 Executive Staff 4 Computer 460 Personnel Cost in Dollars | 1 Support Staff 4 Pertmaster Software | |
| | => 2 | => 4 | | GM Develop Production Plan | 2 Executive Staff 2 Computer 460 Personnel Cost in Dollars | 1 Support Staff 2 Pertmaster Software | |
| | 4 | 1 | => 3 | => 4 | 3 GM Negotiate License Agreements | 1 Executive Staff 1 Computer 260 Personnel Cost in Dollars | 1 Support Staff 1 Pertmaster Software |
| | 6 | 1 | => 4 | => 5 | 2 GM Approve Product Plans and Design | 4 Executive Staff 2 Computer 860 Personnel Cost in Dollars | 1 Support Staff 2 Pertmaster Software |
| 3 | 2 | => | | | | | |
| 3 | 3 | => | | | | | |
| >> 5 << MILESTONE FINISH INITIAL PLANNING | | | | | | | |
| | 2 | 4 | => 5 | => 6 | 3 GM Create and Approve Product Budget | 1 Executive Staff 2 Computer 2 Database Software | 2 Support Staff 2 Pertmaster Software 320 Personnel Cost in Dollars |
| | 3 | 5 | => 6 | => 7 | 3 GM Appoint Product Manager | 2 Executive Staff 1 Computer 1 Database Software | 1 Support Staff 1 Pertmaster Software 460 Personnel Cost in Dollars |
| >> 7 << MILESTONE READY TO INITIATE PRODUCT PLANS | | | | | | | |
| | 3 | 6 | => 7 | => 8 | 3 MP Order Product Materials | 1 Product Manager 2 Computer 2 Database Software | 2 Support Staff 1 Pertmaster Software 310 Personnel Cost in Dollars |

- (A) Milestone (no duration, no resources)
- (B) Preceding activity duration
- (C) Preceding activity nodes
- (D) Current activity nodes
- (E) Current activity duration
- (F) Current activity description
- (G) Current activity resources

PRECEDENCE PLAN ACTIVITY LISTING

| Westminster Software Inc. | | MARKETING A NEW PRODUCT | | Palo Alto, California 94304 | |
|-------------------------------|-------|------------------------------|-------|--|--|
| REPORT TYPE: PERT/CPM LISTING | | PLAN I.D.: PRODUCT VERSION 0 | | PRINTING SEQUENCE: Node/Activity Number Sequence | |
| LNK PREC | | SUCC DIR | | SELECTION CRITERIA: ALL | |
| ACT ACT | | ACT ACT | | TIME NOW DATE: 1/JUN/84 | |
| | | DESCRIPTION | | RESOURCES | |
| | START | 0 | START | | |
| | =>2 | 0 | F->S | | |
| | =>3 | 0 | F->S | | |
| | =>4 | 0 | F->S | | |
| | =>5 | 0 | F->S | | |
| | =>6 | 0 | F->S | | |
| | =>7 | 0 | F->S | | |
| | =>8 | 0 | F->S | | |
| | =>9 | 0 | F->S | | |
| | =>10 | 0 | F->S | | |
| | =>11 | 0 | F->S | | |
| | =>12 | 0 | F->S | | |
| | =>13 | 0 | F->S | | |
| | =>14 | 0 | F->S | | |
| | =>15 | 0 | F->S | | |
| | =>16 | 0 | F->S | | |
| | =>17 | 0 | F->S | | |
| | =>18 | 0 | F->S | | |
| | =>19 | 0 | F->S | | |
| | =>20 | 0 | F->S | | |
| | =>21 | 0 | F->S | | |
| | =>22 | 0 | F->S | | |
| | =>23 | 0 | F->S | | |
| | =>24 | 0 | F->S | | |
| | =>25 | 0 | F->S | | |
| | =>26 | 0 | F->S | | |
| | =>27 | 0 | F->S | | |
| | =>28 | 0 | F->S | | |
| | =>29 | 0 | F->S | | |
| | =>30 | 0 | F->S | | |
| | =>31 | 0 | F->S | | |
| | =>32 | 0 | F->S | | |
| | =>33 | 0 | F->S | | |
| | =>34 | 0 | F->S | | |
| | =>35 | 0 | F->S | | |
| | =>36 | 0 | F->S | | |
| | =>37 | 0 | F->S | | |
| | =>38 | 0 | F->S | | |
| | =>39 | 0 | F->S | | |
| | =>40 | 0 | F->S | | |
| | =>41 | 0 | F->S | | |
| | =>42 | 0 | F->S | | |
| | =>43 | 0 | F->S | | |
| | =>44 | 0 | F->S | | |
| | =>45 | 0 | F->S | | |
| | =>46 | 0 | F->S | | |
| | =>47 | 0 | F->S | | |
| | =>48 | 0 | F->S | | |
| | =>49 | 0 | F->S | | |
| | =>50 | 0 | F->S | | |
| | =>51 | 0 | F->S | | |
| | =>52 | 0 | F->S | | |
| | =>53 | 0 | F->S | | |
| | =>54 | 0 | F->S | | |
| | =>55 | 0 | F->S | | |
| | =>56 | 0 | F->S | | |
| | =>57 | 0 | F->S | | |
| | =>58 | 0 | F->S | | |
| | =>59 | 0 | F->S | | |
| | =>60 | 0 | F->S | | |
| | =>61 | 0 | F->S | | |
| | =>62 | 0 | F->S | | |
| | =>63 | 0 | F->S | | |
| | =>64 | 0 | F->S | | |
| | =>65 | 0 | F->S | | |
| | =>66 | 0 | F->S | | |
| | =>67 | 0 | F->S | | |
| | =>68 | 0 | F->S | | |
| | =>69 | 0 | F->S | | |
| | =>70 | 0 | F->S | | |
| | =>71 | 0 | F->S | | |
| | =>72 | 0 | F->S | | |
| | =>73 | 0 | F->S | | |
| | =>74 | 0 | F->S | | |
| | =>75 | 0 | F->S | | |
| | =>76 | 0 | F->S | | |
| | =>77 | 0 | F->S | | |
| | =>78 | 0 | F->S | | |
| | =>79 | 0 | F->S | | |
| | =>80 | 0 | F->S | | |
| | =>81 | 0 | F->S | | |
| | =>82 | 0 | F->S | | |
| | =>83 | 0 | F->S | | |
| | =>84 | 0 | F->S | | |
| | =>85 | 0 | F->S | | |
| | =>86 | 0 | F->S | | |
| | =>87 | 0 | F->S | | |
| | =>88 | 0 | F->S | | |
| | =>89 | 0 | F->S | | |
| | =>90 | 0 | F->S | | |
| | =>91 | 0 | F->S | | |
| | =>92 | 0 | F->S | | |
| | =>93 | 0 | F->S | | |
| | =>94 | 0 | F->S | | |
| | =>95 | 0 | F->S | | |
| | =>96 | 0 | F->S | | |
| | =>97 | 0 | F->S | | |
| | =>98 | 0 | F->S | | |
| | =>99 | 0 | F->S | | |
| | =>100 | 0 | F->S | | |
| | =>101 | 0 | F->S | | |
| | =>102 | 0 | F->S | | |
| | =>103 | 0 | F->S | | |
| | =>104 | 0 | F->S | | |
| | =>105 | 0 | F->S | | |
| | =>106 | 0 | F->S | | |
| | =>107 | 0 | F->S | | |
| | =>108 | 0 | F->S | | |
| | =>109 | 0 | F->S | | |
| | =>110 | 0 | F->S | | |
| | =>111 | 0 | F->S | | |
| | =>112 | 0 | F->S | | |
| | =>113 | 0 | F->S | | |
| | =>114 | 0 | F->S | | |
| | =>115 | 0 | F->S | | |
| | =>116 | 0 | F->S | | |
| | =>117 | 0 | F->S | | |
| | =>118 | 0 | F->S | | |
| | =>119 | 0 | F->S | | |
| | =>120 | 0 | F->S | | |
| | =>121 | 0 | F->S | | |
| | =>122 | 0 | F->S | | |
| | =>123 | 0 | F->S | | |
| | =>124 | 0 | F->S | | |
| | =>125 | 0 | F->S | | |
| | =>126 | 0 | F->S | | |
| | =>127 | 0 | F->S | | |
| | =>128 | 0 | F->S | | |
| | =>129 | 0 | F->S | | |
| | =>130 | 0 | F->S | | |
| | =>131 | 0 | F->S | | |
| | =>132 | 0 | F->S | | |
| | =>133 | 0 | F->S | | |
| | =>134 | 0 | F->S | | |
| | =>135 | 0 | F->S | | |
| | =>136 | 0 | F->S | | |
| | =>137 | 0 | F->S | | |
| | =>138 | 0 | F->S | | |
| | =>139 | 0 | F->S | | |
| | =>140 | 0 | F->S | | |
| | =>141 | 0 | F->S | | |
| | =>142 | 0 | F->S | | |
| | =>143 | 0 | F->S | | |
| | =>144 | 0 | F->S | | |
| | =>145 | 0 | F->S | | |
| | =>146 | 0 | F->S | | |
| | =>147 | 0 | F->S | | |
| | =>148 | 0 | F->S | | |
| | =>149 | 0 | F->S | | |
| | =>150 | 0 | F->S | | |
| | =>151 | 0 | F->S | | |
| | =>152 | 0 | F->S | | |
| | =>153 | 0 | F->S | | |
| | =>154 | 0 | F->S | | |
| | =>155 | 0 | F->S | | |
| | =>156 | 0 | F->S | | |
| | =>157 | 0 | F->S | | |
| | =>158 | 0 | F->S | | |
| | =>159 | 0 | F->S | | |
| | =>160 | 0 | F->S | | |
| | =>161 | 0 | F->S | | |
| | =>162 | 0 | F->S | | |
| | =>163 | 0 | F->S | | |
| | =>164 | 0 | F->S | | |
| | =>165 | 0 | F->S | | |
| | =>166 | 0 | F->S | | |
| | =>167 | 0 | F->S | | |
| | =>168 | 0 | F->S | | |
| | =>169 | 0 | F->S | | |
| | =>170 | 0 | F->S | | |
| | =>171 | 0 | F->S | | |
| | =>172 | 0 | F->S | | |
| | =>173 | 0 | F->S | | |
| | =>174 | 0 | F->S | | |
| | =>175 | 0 | F->S | | |
| | =>176 | 0 | F->S | | |
| | =>177 | 0 | F->S | | |
| | =>178 | 0 | F->S | | |
| | =>179 | 0 | F->S | | |
| | =>180 | 0 | F->S | | |
| | =>181 | 0 | F->S | | |
| | =>182 | 0 | F->S | | |
| | =>183 | 0 | F->S | | |
| | =>184 | 0 | F->S | | |
| | =>185 | 0 | F->S | | |
| | =>186 | 0 | F->S | | |
| | =>187 | 0 | F->S | | |
| | =>188 | 0 | F->S | | |
| | =>189 | 0 | F->S | | |
| | =>190 | 0 | F->S | | |
| | =>191 | 0 | F->S | | |
| | =>192 | 0 | F->S | | |
| | =>193 | 0 | F->S | | |
| | =>194 | 0 | F->S | | |
| | =>195 | 0 | F->S | | |
| | =>196 | 0 | F->S | | |
| | =>197 | 0 | F->S | | |
| | =>198 | 0 | F->S | | |
| | =>199 | 0 | F->S | | |
| | =>200 | 0 | F->S | | |
| | =>201 | 0 | F->S | | |
| | =>202 | 0 | F->S | | |
| | =>203 | 0 | F->S | | |
| | =>204 | 0 | F->S | | |
| | =>205 | 0 | F->S | | |
| | =>206 | 0 | F->S | | |
| | =>207 | 0 | F->S | | |
| | =>208 | 0 | F->S | | |
| | =>209 | 0 | F->S | | |
| | =>210 | 0 | F->S | | |
| | =>211 | 0 | F->S | | |
| | =>212 | 0 | F->S | | |
| | =>213 | 0 | F->S | | |
| | =>214 | 0 | F->S | | |
| | =>215 | 0 | F->S | | |
| | =>216 | 0 | F->S | | |
| | =>217 | 0 | F->S | | |
| | =>218 | 0 | F->S | | |
| | =>219 | 0 | F->S | | |
| | =>220 | 0 | F->S | | |
| | =>221 | 0 | F->S | | |
| | =>222 | 0 | F->S | | |
| | =>223 | 0 | F->S | | |
| | =>224 | 0 | F->S | | |
| | =>225 | 0 | F->S | | |
| | =>226 | 0 | F->S | | |
| | =>227 | 0 | F->S | | |
| | =>228 | 0 | F->S | | |
| | =>229 | 0 | F->S | | |
| | =>230 | 0 | F->S | | |
| | =>231 | 0 | F->S | | |
| | =>232 | 0 | F->S | | |
| | =>233 | 0 | F->S | | |
| | =>234 | 0 | F->S | | |
| | =>235 | 0 | F->S | | |
| | =>236 | 0 | F->S | | |
| | =>237 | 0 | F->S | | |
| | =>238 | 0 | F->S | | |

STANDARD REPORT LISTING

The printed Standard Report Listing is similar to the Screen List, and is produced by selecting option 1 on the Report Menu. As with the Screen Reports, you can select the order in which activities appear on the report.

You can also implement selective reporting, which has one additional feature. If you want a Milestone Report, which will show only those activities which have been so designated in your plan, type **MILESTONE**, in capital letters, as the selection key. Node and activity numbers never appear on a Milestone Report.

The Standard Report Listing is listed as a **STANDARD REPORT** under **Reports Listed So Far**. The printed report is called a STANDARD LISTING. The following are samples of printed Standard Reports and Milestone Reports.

STANDARD LISTING

| XYZ Products, Inc. | | SUPER-WIDGET | | | PRINTING SEQUENCE : Earliest Activities First | | Menlo Park, CA. | | |
|--------------------------------|----------------|--------------------|--------------|---------------|---|-------------------------|-----------------|--------------------------|--|
| REPORT TYPE : STANDARD LISTING | | PLAN I.D. : WIDGET | | VERSION : 0 | | SELECTION CRITERIA: ALL | | TIME NOW DATE : 1/JUN/84 | |
| ACTIVITY DESCRIPTION | EARLIEST START | EARLIEST FINISH | LATEST START | LATEST FINISH | DURATION | FLOAT | | | |
| 2 Approve Product Design | 1/JUN/84 | 6/JUN/84 | 1/JUN/84 | 6/JUN/84 | 4 | 0 * | | | |
| 7 Produce First Units | 7/JUN/84 | 12/JUL/84 | 7/JUL/84 | 12/JUL/84 | 25 | 0 * | | | |
| 6 Appoint Distributors | 7/JUN/84 | 27/JUN/84 | 21/JUN/84 | 12/JUL/84 | 15 | 10 | | | |
| 3 Train Sales Force | 7/JUN/84 | 20/JUN/84 | 28/JUN/84 | 12/JUL/84 | 10 | 15 | | | |
| 4 Prepare Sales Documents | 7/JUN/84 | 14/JUN/84 | 3/JUL/84 | 11/JUL/84 | 6 | 10 | | | |
| 20 Product Launch | 13/JUL/84 | 26/JUL/84 | 13/JUL/84 | 26/JUL/84 | 10 | 0 * | | | |

(A) Activity number for Precedence plan. Report will show node numbers for Arrow plan. Numbers can be suppressed to conserve memory; see Reference Section 5.4.

(B) Asterisk marker on critical activities.

MILESTONE REPORT

| Westminster Software Inc. | | MARKETING A NEW PRODUCT | | | PRINTING SEQUENCE : Earliest Activities First | | Palo Alto CA 94304 | | |
|---------------------------------|---------------------|-------------------------|--|-------------|---|--------------------------------|--------------------|--------------------------|--|
| REPORT TYPE : MILESTONE | | PLAN I.D. : MARKET | | VERSION : 0 | | SELECTION CRITERIA : MILESTONE | | TIME NOW DATE : 1/JUN/84 | |
| MILESTONE DESCRIPTION | EARLIEST EVENT TIME | LATEST EVENT TIME | | | | | | | |
| START PRODUCT PLANNING | 1/JUN/84 | 1/JUN/84 | | | | | | | |
| FINISH INITIAL PLANNING | 13/JUN/84 | 13/JUN/84 | | | | | | | |
| READY TO INITIATE PRODUCT PLANS | 21/JUN/84 | 21/JUN/84 | | | | | | | |
| SALES CONFERENCE | 26/JUL/84 | 8/AUG/84 | | | | | | | |
| SALES STAFF READY TO SELL | 27/JUL/84 | 9/AUG/84 | | | | | | | |
| PRODUCT READY TO SHIP | 30/AUG/84 | 30/AUG/84 | | | | | | | |

(A) Activity and node numbers never shown.

PROJECT OR PERIOD BARCHARTS

Option 2 of the Report Menu can provide two types of printed barcharts. The Period Barchart covers the plan from a starting day which you designate. It always fills the width of your printer paper, and may be scaled in time.

The Project Barchart covers the entire plan, and may require several sheets of paper, depending on the calendar in use. Non-working days are ignored in either type.

As with the Screen Barchart, printed barcharts show critical activities, non-critical activities, and negative float. Float on non-critical activities is optional, and is determined by a choice made in setting up your system details; see Reference Section 5.4.

The order in which activities appear on the reports, as well as selective reporting, are available options on both types of barcharts.

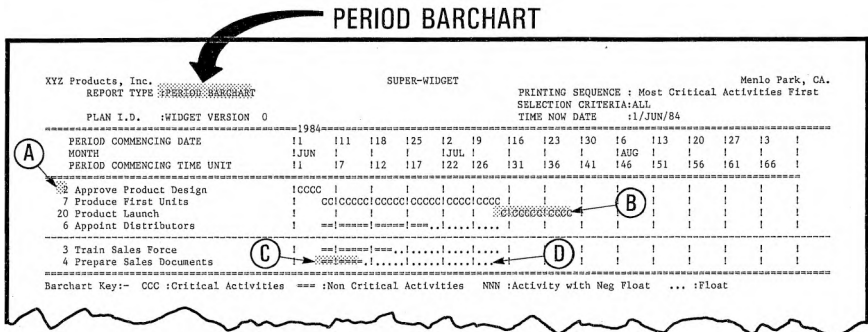

- (A) Activity number for Precedence plan.
Report will show node numbers for Arrow plan.
Numbers can be suppressed to conserve memory.*
- (B) Critical activity.
- (C) Non-critical activity.
- (D) Float, which will not be shown if float is turned off.*

*See Reference Section 5.4

PROJECT BARCHART

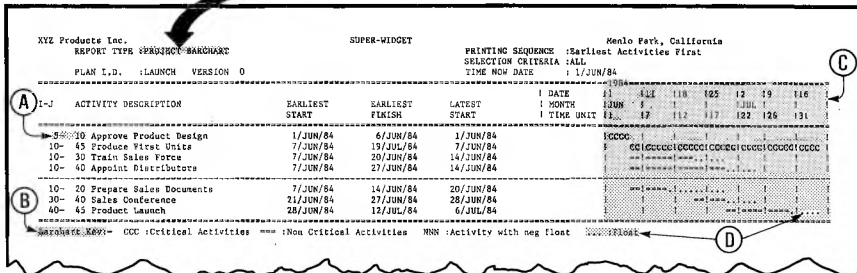

- (A) Node numbers for Arrow plan. Report will show activity number for Precedence plan. Numbers can be suppressed to conserve memory.*
- (B) Barchart Key
- (C) This portion of barchart is printed separately, and is shown pasted in place.
- (D) Float will not be shown if float is turned off.*

*See Reference Section 5.4

CASH-FLOW CURVE FOR EXPENDABLE RESOURCE

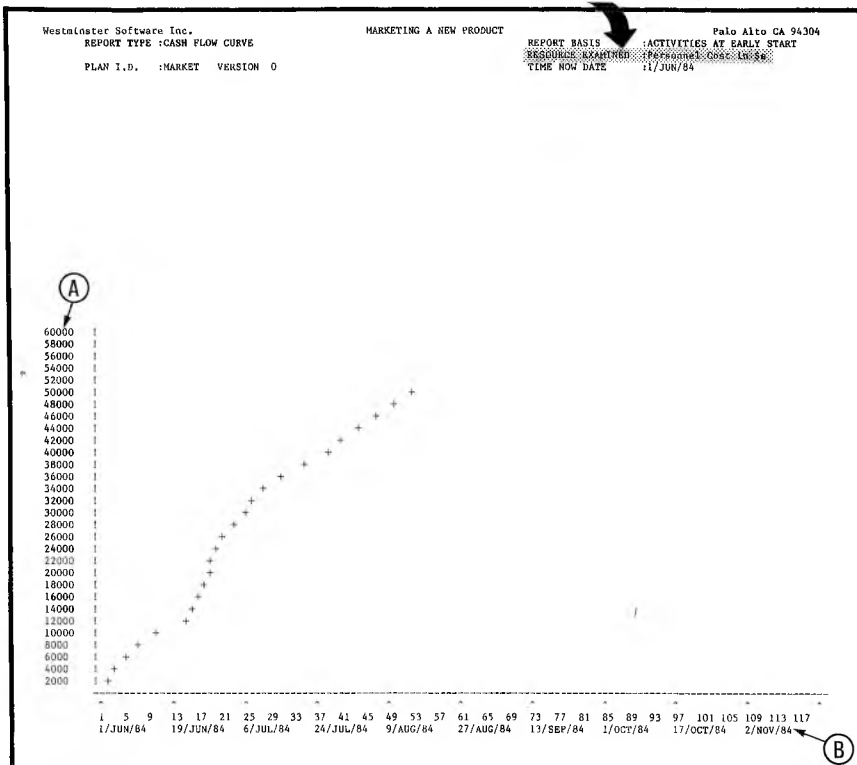

- (A) Quantity is scaled automatically unless scale is specified. This scale has been set manually to start at 2000 and end at 60000 dollars.
- (B) Time scale is based on printer character width and paper width.

PERTMASTER'S HOUSEKEEPING FACILITIES

Up to now, you may have used one or two of the facilities which are grouped under the broad term "Housekeeping." These would have covered configuring your computer and your printer to PERTMASTER, which were described in Chapter 4.

Furthermore, throughout the preceding chapters of this manual, you have been using the sample calendar and abbreviations files supplied to on the program disk(s). Now, let's look at all of PERTMASTER's Housekeeping facilities, especially with a view of setting up new calendar and abbreviations files.

Call up PERTMASTER and select option 3, **Do Some Housekeeping**, from the Main Menu. This will cause the following Housekeeping Menu to be displayed.

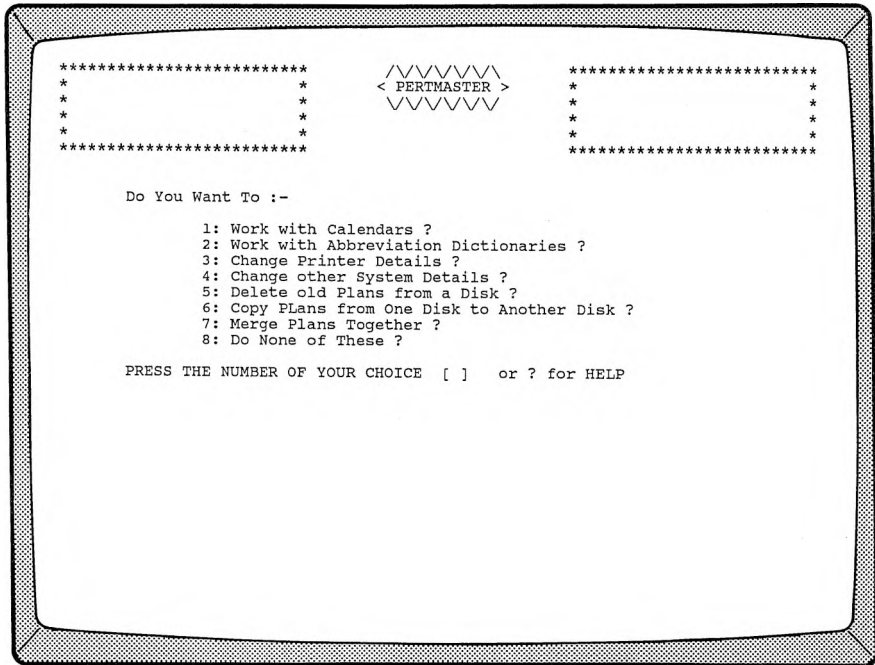

CALENDAR FILES

Selecting the first option on this menu allows you to **Work with Calendars**. You know by now that you must have a calendar file before you can create a new plan. Detailed instructions which will enable you to create a new calendar file or to change an existing calendar appear in PERTMASTER's Reference Manual, starting with Section 5.1. However, there are a few more things that you should know about calendars.

First of all, you should be aware of how PERTMASTER uses calendar dates. Conventionally, an activity always starts at the beginning of the starting day and always finishes at the end of the designated finish day. Therefore, if an activity takes two days and its start date is 15 May 1984, its finish date will be 16 May 1984.

Another interesting feature of PERTMASTER's calendar manipulations permits you to establish any time units that you may want — they do not have to be actual calendar periods, or divisions thereof. For example, suppose that you want to work with time periods expressed in seconds or even in light-years. Neither of these could be considered calendar periods in the normal sense. All you have to do is create a calendar file with the name of your choice and which is only one month long, as explained in Reference Section 5.1.1.

Now, when PERTMASTER asks you to enter the normal working week, simply type *N* (non-working) for each day. When the succeeding Calendar Change/Display Menu appears, select option 7, **Save this Calendar and Return**. Next, the Calendar Menu will reappear, allowing you to choose option 5, **Finish Working with Calendars**.

What you have done is create a calendar without any working days. Its range is of no consequence. As far as PERTMASTER is concerned, all of its calculations will be made in time units which are not defined. Therefore, the time units that you use when you create your plan using this calendar file will be whatever you want them to be — seconds, light-years, etc.

ABBREVIATIONS FILES

Creating a new plan also requires that you have an abbreviations file. This file must contain abbreviations that you use for your activities and abbreviations for your resources. Option 2 on the Housekeeping Menu is used to **Work with Abbreviations Dictionaries**. Reference Section 5.2 provides all the information which you will need to set up a new abbreviations file or to change an existing file.

But supposing you are working with a small plan which does not really call for abbreviations, and you do not want to track any of your resources. You still need an abbreviations file name so that PERTMASTER can use the plan. There are two ways to go about this. You can tell PERTMASTER that you are going to use any abbreviations file that happens to be on your Data Disk, and then just not use any of the abbreviations that are in that file. (You won't be able to use any new abbreviations either, because PERTMASTER will look for them in that file.)

The other way, and one which can apply to any plan for which you don't want an abbreviations file, is to set up a dummy file. This is an abbreviations file that has a name, but has nothing entered in it.

To do this, follow the instructions in Reference Section 5.2, using any file name that you wish; *NONE* might be a good choice. When PERTMASTER asks you to

Type the Next Description

press **◀ESCAPE▶**. Then when the next menu appears, select option 5, **Save This Version & Return**. You now have an empty abbreviations file whose name you can use whenever you choose not to use abbreviations.

CALENDARS, ABBREVIATIONS, AND COMPUTER MEMORY

PERTMASTER makes use of a large amount of computer memory. Although a realistic limit is set for each computer, it is still possible for you to overload your computer's memory.

The following factors have a great effect on memory availability:

1. The configuration of your computer.
2. The total length of your descriptions and the amount of resources.
3. The size of the calendar and abbreviation files.

You can save memory space by economizing on the last two items. If you do approach a memory-full condition, this will usually occur when you are entering new activities. You may notice the computer slowing down for about five seconds between pressing **◀RETURN▶** and the reappearance of the cursor. This is a warning of impending problems.

Eventually, if you continue to add activities, PERTMASTER will give up. On most computers, PERTMASTER will give a memory-full message. You will then be asked to press **◀RETURN▶** to continue.

At this stage, you will return to the amend screen, where you must delete some activities or shorten some descriptions before proceeding.

MERGING PLANS

PERTMASTER has the capability of merging several plans into an overall plan, which is an extremely useful feature. (Detailed instructions for merging plans may be found in Reference Section 5.7.)

When you merge plans, PERTMASTER allows you to add or subtract a constant number from the activity or node numbers in the plan being merged. This, of course, is used to eliminate duplication of activity or node numbers in the overall plan that is being created. You may also add up to twenty characters at any position in the activity descriptions. These additional characters are constant for each plan being merged, and will be placed in the same position in each description. However, they can be changed for each individual plan being merged.

An example of merging might be applied to a small construction project involving five houses. Since the activities for each house should be identical, you would create a plan for one house which might include 30 activities. Then you could create an overall plan into which you merged the individual house plan five times.

Since you can change the activity numbers as you merge individual plans, you might add 100 to them when you merge the first plan, then 200 when you merge the same plan a second time, and so on. This will automatically tell you that activity or node numbers in the 100 series apply to the first house, those in the 200 series apply to the second house, etc.

You might further identify the activities by adding the house number to the description. For example, you could add the phrase *No. 1* to the beginning of each description for the first merge, right through *No. 5* for the last merge.

Your overall plan would contain 150 activities in five distinct phases. Each phase would be distinguishable by virtue of a unique series of activity or node numbers and by the addition of the house number at the beginning of each description.

Because the merge facility allows you to change the activity or node numbers by a constant additive or subtractive amount, it can also be used only to change the activity or node numbers in a plan. Simply by merging a single plan into one having the same name, you will create a new version 0 of the same plan with the new numbers that you have designated.

You must be aware that it is also very easy to exceed the remaining disk space or the available memory in your computer when using the merge facility, especially if you are merging large plans. In this case, PERTMASTER may not be able to warn you that it is being overloaded, and might come to a halt with no explanation.

Most computers can tell you how much space each file takes on disk and how much space remains on the disk. (See your computer manual for this information.) PERTMASTER can tell you how much memory is available if you type *F* when either the Main Menu or the Housekeeping Menu is displayed. If the sum of the disk space used by the plans which you are going to merge is less than the **FREE SPACE** displayed on your screen when you type *F*, you should have no problem in merging the plans.

When you save the new overall plan, you may get an error message telling you that your data disk is full. In this case, you must place a new formatted disk in the Data Drive to receive the new plan.

OTHER HOUSEKEEPING FACILITIES

The other options on the Housekeeping Menu, which are fully explained in Section 5 of the Reference Manual, comprise the following:

- Changing printer details
- Changing certain system details
- Deleting plans from the data disk
- Copying plans from one disk to another

Even though these options are used only occasionally, we suggest that you glance at Reference Sections 5.3 through 5.6 when you have finished with this chapter. When you actually have to use one of these facilities, you will find complete instructions in the applicable reference section.

REFERENCE MANUAL

PERTMASTER™

Westminster
 Software

| <i>Section</i> | <i>Title</i> | <i>Page</i> |
|----------------|---|-------------|
| 1 | INTRODUCTION | 2-1 |
| 2 | MAIN MENU | 2-2 |
| 3 | PLANS | 2-4 |
| 3.1 | New Plan | 2-6 |
| 3.1.1 | New Arrow Plan | 2-9 |
| 3.1.2 | New Precedence Plan | 2-15 |
| 3.2 | Change Existing Plan | 2-21 |
| 3.2.1 | Enter/Change Resources | 2-26 |
| 3.2.2 | Save/Abandon Plan Menu | 2-29 |
| 4 | REPORTS | 2-31 |
| 4.1 | Standard Report | 2-35 |
| 4.1.1 | Selective Reporting Menu | 2-38 |
| 4.2 | Project or Period Barchart | 2-40 |
| 4.2.1 | Selective Reporting Menu | 2-43 |
| 4.2.2 | Barchart Report Menu | 2-45 |
| 4.3 | Resources Report | 2-47 |
| 4.4 | Resource Histogram | 2-49 |
| 4.5 | Screen Report | 2-52 |
| 4.5.1 | Selective Reporting Menu, Screen Barchart | 2-55 |
| 4.5.2 | Commands, Screen List, Screen Histogram | 2-57 |
| 4.6 | Disk Report | 2-61 |
| 4.6.1 | Time Analysis Report | 2-63 |
| 4.6.1.1 | Selective Reporting Menu | 2-66 |
| 4.6.1.2 | Time Analysis Report Format | 2-68 |
| 4.6.2 | Resources Report Format | 2-70 |
| 5 | HOUSEKEEPING | 2-72 |
| 5.1 | Calendars | 2-74 |
| 5.1.1 | Create New Calendar File | 2-76 |
| 5.1.2 | Change/Display Existing Calendar | 2-79 |
| 5.1.2.1 | Calendar Change/Display Menu | 2-80 |
| 5.2 | Abbreviations | 2-84 |
| 5.2.1 | Create New Abbreviations File | 2-87 |
| 5.2.2 | Change/Display Abbreviations File | 2-89 |
| 5.2.2.1 | Abbreviations Change/Display Menu | 2-90 |

| | | |
|------------|---|-------|
| 5.3 | Change Printer Details | 2-92 |
| 5.4 | Change System Details | 2-95 |
| 5.5 | Delete Old Plans | 2-97 |
| 5.6 | Copy Plans | 2-99 |
| 5.7 | Merge Plans Together | 2-101 |
| Appendix A | PRODUCT SPECIFICATIONS AND DESCRIPTION | A-1 |
| Appendix B | ERROR MESSAGES | B-1 |
| Appendix C | EXPERT USERS FEATURES | C-1 |
| Appendix D | USING PERTMASTER WITH OTHER PROGRAMS | D-1 |
| Appendix E | CUSTOMIZING PERTMASTER | E-1 |

Section 1

The PERTMASTER Reference Manual has been divided into a number of sections, carefully arranged so that you can use them easily. Although you will find the User's Manual helpful while you are getting to know PERTMASTER, the Reference Sections makes looking for specific information easy.

We have organized this manual so that it follows the sequence of the menus and displays as they appear in the program. Thus, we have started with the Main Menu, which appears each time PERTMASTER is called, and have proceeded through each succeeding menu and sub-menu. We believe that this will allow you to follow a direct and logical sequence when using the manual.

The five major Reference Sections are as follows:

- Section 1 - Introduction
- Section 2 - Main Menu
- Section 3 - Plans
- Section 4 - Reports
- Section 5 - Housekeeping

Sections 3, 4, and 5 are further broken down to more detailed sub-sections, to which you can go directly or by reference from a preceding section. In this way, you should be able to find the information you require with a minimum of time and effort.

We have also included a quick reference guide card with the manual. This card can be taken out of the manual and placed near your computer while you are working. It contains a complete list of all the commonly used commands and features.

PERTMASTER is loaded by typing **CONTROL** and pressing **◀RETURN▶**. After the copyright notice appears, the Main Menu will be displayed as shown below.

NOTE: If you type **F** before making a selection, the **FREE SPACE** (in bytes or characters) remaining in memory will be displayed. Since a plan has not been loaded at this time, this feature tells you how much space is available in memory for your plans.

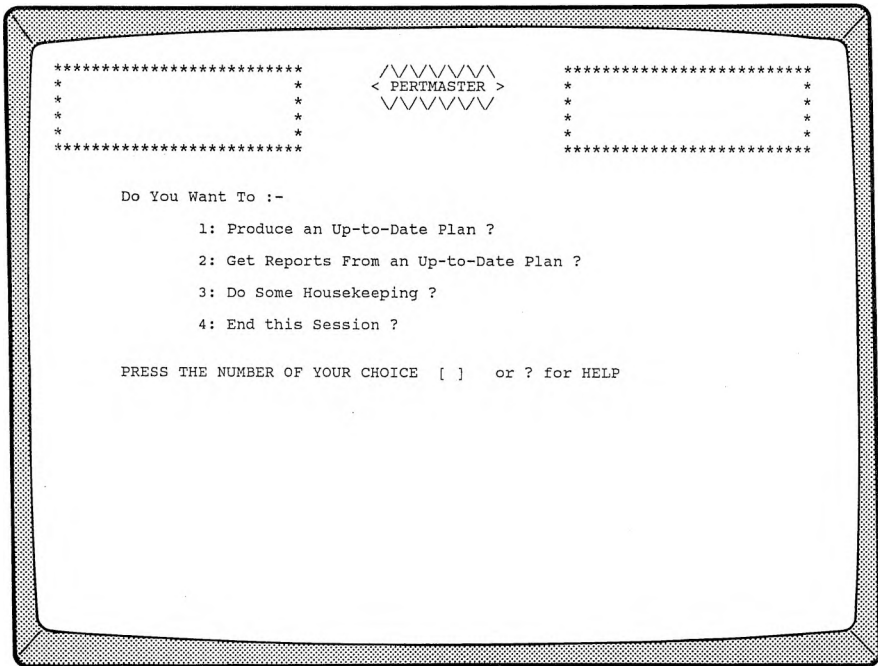

1. Produce an Up-to-Date Plan

[See Section 3]

Selecting option 1 allows you to produce a new plan or change an existing plan.

2. Get Reports From an Up-to-Date Plan [See Section 4]

Option 2 provides management reports which PERTMASTER generates from an existing plan.

3. Do Some Housekeeping [See Section 5]

Housekeeping covers the preliminary work which must be done before a plan can be produced, plus utilities for deleting and copying files. It includes:

- Setting up and maintaining work calendars
- Setting up and maintaining abbreviation lists
- Defining the way in which a printer will work with PERTMASTER
- Setting up certain system details which affect reports and which selects the disk drive for your plans
- Deleting, copying, and merging plans

4. End this Session

Returns you to the computer operating system.

2. Change an Existing Plan

[See Section 3.2]

If you want to work with one of the plans listed on the screen, type the number to the left of the plan name.

It is possible that this list may be out of date, or even completely lost. If you want to load a plan that you know is recorded on the data disk, but which isn't shown on the list of plans, see paragraphs 3 and 4, below.

3. Last Option on Menu

If the last option on the screen is **NONE OF THESE**, all of the plans available on the data disk have been listed on the screen. Selecting this option returns you to the Main Menu.

If the last option on the screen is **OTHER PLANS ON DISK**, choosing this option will cause additional plans to be listed on the screen.

4. Manual Load

To load a plan which is on the disk, but is not listed on the screen, enter *M* instead of an option number on the menu. PERTMASTER will then print a directory of all the files on the data disk. Plans may be identified by the version number printed to the right of the decimal point.

PERTMASTER will ask you for the plan name — type in the plan name and press ◀RETURN▶. Then PERTMASTER will ask you for the version number — type in the version number and press ◀RETURN▶. PERTMASTER will then load your plan.

If the plan name is not in the directory, press ◀ESCAPE▶ or ◀RETURN▶ in response to each question to return to the Main Menu. An error message will appear instructing you to press ◀RETURN▶ again.

A NEW PROJECT PLAN

[Option 1 on Plans Menu]

When option 1 on the Plans Menu is selected to create a new plan, the following menu will be displayed.

```
Please Enter The Following Information :-  
-----  
Plan File Identification (1 to 8 Letters): [      ]  
Left Hand Report Title (Upto 30 Letters):  
Centre Report Title (Upto 30 Letters):  
Right Hand Report Title (Upto 30 Letters):  
Calendar Code-Name (1 to 8 Letters):  
Abbreviations Code-Name (1 to 8 Letters):  
Plan Format Type (A=Arrow, P=Precedence):  
Time Units per Day (Numeric,Upto 3 digits):  
  
NOTE: Press RETURN only to skip Item, or to Leave it Unchanged  
Press ESCAPE to Back Up One Steo, or ? for HELP
```

1. Plan File Identification.

Enter a name for the plan that you are going to create, then press **◀RETURN▶**. This name is limited to eight characters. It must start with a letter, may not contain a space, and otherwise contain only letters and numbers. PERTMASTER will reject an invalid entry.

2. Report Title(s).

The next three questions refer to the three titles that can be printed at the top of each report generated by PERTMASTER from your

plan. These are limited in length to 30 characters. These titles are optional, but can be used to provide descriptive information about your plan. Press ◀RETURN▶ after typing each title.

3. Calendar Code-Name.

Every plan must work with a calendar file. Even if you have not created the calendar that you wish to use with this plan, you must enter a calendar name at this time. The calendar that you name must be created before you can get any printed reports from PERTMASTER. This name is limited to eight characters. It must start with a letter, may not contain a space, and otherwise contain only letters and numbers. Press ◀RETURN▶ after typing the file name. PERTMASTER will reject an invalid entry.

4. Abbreviations Code-Name.

Every plan must work with an abbreviations file. Even if you do not plan to use abbreviations, or if you have not yet created the abbreviations file that you wish to use with this plan, you must enter a file name at this time. The file that you name must be created before you can get any printed reports from PERTMASTER. This name is limited to eight characters. It must start with a letter, may not contain a space, and otherwise contain only letters and numbers. Press ◀RETURN▶ after typing the file name. PERTMASTER will reject an invalid entry.

5. Plan Format Type.

This question must be answered with either an *A* (Arrow) or *P* (Precedence), as dictated by your format choice, followed by ◀RETURN▶. It determines how PERTMASTER will accept your input and process your plan.

Refer to Section 3.1.1 for details on entering data for Arrow Plans.

Refer to Section 3.1.2 for details on entering data for Precedence Plans.

6. Time Units per Day.

Section 5.1.1 describes the procedure for establishing the main time unit for your calendar. The **Time Units per Day** entry allows you to divide your main time unit into sub-time units, and is the number of sub-time units that you wish your main time unit to contain.

For example, you may have created a calendar in units of days. A day will be your main time unit in this case. However, it may be

more convenient for you to enter the activities of your plan in terms of shifts. If you are working three shifts a day, set this figure to 3 and press ◀RETURN▶. If you do not wish to subdivide the day, leave this figure at 1.

NOTE: If you subdivide your time units, PERTMASTER will still provide reports using the main time unit for titles. For instance, taking again the example of a working day divided into three shifts, PERTMASTER might report that a certain activity started on 2/JUL/84, but it would not tell you which shift.

If you have made an error in any of the entries, press ◀ESCAPE▶. This will take you back an entry, so that you can correct it.

If you press ◀ESCAPE▶ in place of the first entry (**Plan File Identification**), you will be returned to the Main Menu, and the new project plan request will be cancelled.

When you have entered all the information on this screen, PERTMASTER will ask

All Items Correct ?

If you answer *N* (No), you will be returned to the top of the menu. Then either overtype the incorrect entry or press ◀RETURN▶ until you reach the bottom of the menu. When you answer *Y* (Yes), the screen will change to a format which will allow you to enter your plan. (See Section 3.1.1 or 3.1.2 for Arrow Plans or Precedence Plans respectively.)

NEW ARROW PLAN [Plan Format Selection on New Plan Menu]

After an Arrow Plan format has been selected on the New Plan Menu, the following menu will be displayed.

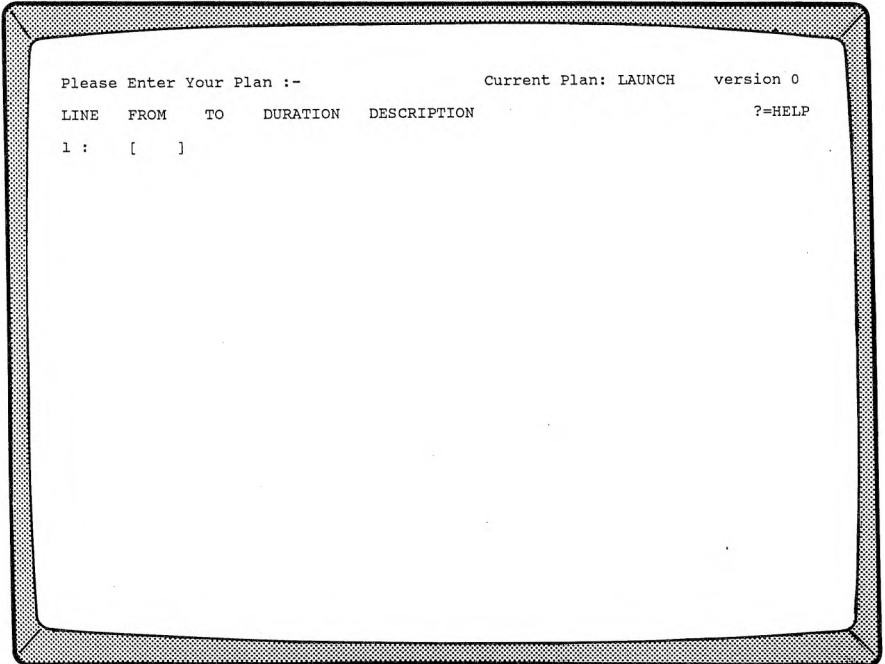

The plan name and version number are shown at the top right corner. If this is a new plan, the version number will be 0. If the plan exists, the version number will be one higher than the plan you loaded. Every time that you work with a PERTMASTER plan, the version number will be increased by one.

ENTERING PLAN ACTIVITIES

Your plan activities are entered in tabular form under the following headings:

LINE. The line numbers which appear in this column are for use as for screen reference points. They will always be numbered from 1 to 19, and do not form part of your plan. You do not type line numbers; they will be entered by the computer.

FROM. This refers to the start, or preceding node, of each activity. Node numbers must be an integer, or whole number, between 1 and the limit of activities for your computer. Press ◀RETURN▶ after entering the number.

TO. This refers to the finish, or succeeding node of each activity. Node numbers must be an integer, or whole number, between 1 and the limit of activities for your computer. Press ◀RETURN▶ after entering the number.

DURATION. Duration is the current best estimate of time it will take to complete the activity. The duration is entered as a number of sub-time units. For example, if you are working with a calendar of days, but have set your sub-time units to 3 in the plan headings, to indicate that you are working 3 shifts to a day, then the duration of each activity is entered in shifts. Durations must be an integer, or whole number, between 0 and 9999, and must be followed by a ◀RETURN▶.

DESCRIPTION. Enter the description that you wish to use to describe the activity in this column, then press ◀RETURN▶. The description may consist of up to 40 characters, and will be used on the reports.

Descriptions can take up a lot of memory. If your plan is large, and the activities have long descriptions, you can easily overload your computer's memory. To reduce the size of a description, you can use abbreviations. If the abbreviation is in the abbreviations file which was entered on the New Plan Menu, the full description will be printed out on the reports which PERTMASTER generates.

You must use an exclamation mark before your two-letter abbreviation to tell PERTMASTER that you are using an abbreviation. For example, if the abbreviation "RT" stands for "Repair and test", then the description

!RT gearbox assembly

would appear on the printed reports as

Repair and test gearbox assembly.

PERTMASTER displays a maximum of 19 lines on the screen. After you have entered 19 activities, the screen will clear and you will be able to continue.

WARNING: If frequent delays are encountered between pressing ◀RETURN▶ and the reappearance of the cursor, then you are approaching your computer's memory limit. Use more abbreviations, fewer nodes, or fewer activities to avoid this.

After you have entered the last activity in your plan, and the cursor is in the **FROM** column on the next line, you exit the entry mode by pressing ◀ESCAPE▶. PERTMASTER will then display the first 19 lines of your plan; succeeding lines can be seen by pressing ◀RETURN▶. You may now make changes, save your plan, or abandon your plan. Refer to Section 3.2.

SPECIAL FEATURES

Pressing ◀RETURN▶ in place of a preceding node will cause the last used preceding node to be used again. A blank will be printed. Thus, you can enter all the activities coming from a particular node without having to retype the node number.

Pressing ◀RETURN▶ for the duration will cause a zero duration to be entered. A zero duration is often necessary with dummy activities.

Pressing ◀RETURN▶ for the description will cause PERTMASTER to record a dummy activity. The word **DUMMY** will be printed on the screen. Because the computer uses its own abbreviation for the word **DUMMY**, memory space will be saved by using this form of input for dummy activities.

You can enter nodes in any sequence; they do not have to be in numeric sequence. It is good practice, however, to follow numeric sequence where possible, starting with low node numbers, and working up to higher node numbers as the plan progresses. Large deviations from this order will delay the analysis of the plan.

If you have made an error in the entry of an activity, press ◀ESCAPE▶. The whole of the activity entry will be cleared, and the cursor will be repositioned in the **FROM** column. Then you can retype the activity. This method can only be used while the cursor is still on the same line as the error. If it is not, use the delete command described in Section 3.2.

STARTS AND FINISHES

Every plan must have at least one start and at least one finish. However, you can use multiple starts and finishes on your networks.

Both starts and finishes may be scheduled or unscheduled. An unscheduled start or finish simply means that it will occur as early as the plan will

allow. A scheduled start means that the start can't happen before a specified day. A scheduled finish means that the finish must be completed by a specified day. You can use these features on any node, thereby forcing time constraints on any part of your plan.

To enter a start, type *S* in place of the preceding node number, under **FROM**, and press ◀RETURN▶. The word **START** will be displayed. Then type in the succeeding node number, in the **TO** column, to indicate the node to which the start applies.

Now PERTMASTER will ask if the start is to be

SCHEDULED (Y/N)

If you type *N* (No), then this start is a simple unscheduled start, which will occur as early as possible (time now).

If you type *Y* (Yes), then this start is to be scheduled. PERTMASTER will then ask

NOT BEFORE DAY

which should be the day number (not a calendar date) on which the activity is to start. Enter the day number, and press ◀RETURN▶. The cursor will then move down one line and wait for the next activity to be entered.

To enter a finish, type the number of the node to which the finish is to be applied in the **FROM** (preceding node) column. Then type *F* in the **TO** (succeeding node) column, and press ◀RETURN▶. The word **FINISH** will be displayed.

At this stage PERTMASTER will ask if the finish is to be

SCHEDULED (Y/N)

If you type *N* (No), then this finish is a simple unscheduled finish, which will occur as early as the design of your network will allow.

If you type *Y* (Yes), then this finish is to be scheduled. PERTMASTER will then ask

NOT AFTER DAY

which should be the day number (not a calendar date) by which the activity is to finish. Enter the day number, and press ◀RETURN▶. The cursor will then move down one line and wait for the next activity to be entered.

Each start and finish counts as an extra activity towards the limit available on your computer.

If you wish to make a scheduled start or finish into an unscheduled one, type a day number of zero.

MILESTONES

Milestones are key dates within your project. They are selected to provide key information to a management level which requires brief information rather than detailed reporting. Milestone events must form part of your plan so that the timing can be calculated. PERTMASTER has a special Milestone Report, described in Section 4.1.1.

Any number of nodes may be designated as milestones within your project. As a guide, between one node in ten and one node in twenty should be made milestones. This figure will depend on the type of reporting you need in your reports.

To enter a milestone, type the node number in the **FROM** (preceding node) column, and press **◀RETURN▶**. Then type **M** instead of a succeeding node number under **TO**, and press **◀RETURN▶**. The word **MILESTONE** will be printed on the screen.

The cursor will now move to the description column. (A milestone is a key date, not an activity, and therefore does not have a duration.) Type your description of the milestone, and press **◀RETURN▶**. The cursor will then move down one line and wait for the next activity to be entered.

SELECTIVE REPORTING

You can design your descriptions to take advantage of the selective output reports. These reports will only contain those activities you specify as having a particular group of characters in some position in the description. Therefore you can use a character, or any group of characters, to indicate a management code, area reference, site code, etc., and tell PERTMASTER to print activities containing only that specific code.

For example, if you want reports covering only assembly operations, you could prefix the descriptions as follows:

Assy - amplifier board
Assy - chassis

You can then ask for a report using a selection key of *Assy* which always starts in the first position of the description.

Alternatively, you may specify the selection key in a random position in the description, where the descriptions might be:

Amplifier board assembly
Chassis assembly and wiring

In this case, if you specify a selection key of *assembly* in a random location, your report will include all activities in which the word “assembly” appears.

The selection key can include up to 38 characters. It may also be the abbreviation for a resource, in which case the report will include only those activities which utilize that resource. For additional information about selective output reports, see Section 4.1.1, 4.2.1, 4.5.1, or 4.6.1.1, as applicable.

RESOURCES

The use of resources and resource tracking is covered in Chapter 9 of the PERTMASTER User’s Guide. See Reference Section 3.2.1 for information on entering and changing resources.

NEW PRECEDENCE PLAN

[Plan Format Selection on
New Plan Menu]

If a Precedence Plan format has been selected on the New Plan Menu, the following menu will be displayed.

```
Enter New Activities :-                Current Plan: WIDGET  version 0
LINE  FROM  TO  DURATION  DESCRIPTION  ?=HELP
1 :  [ ]
```

The plan name and version number are shown at the top right corner. If this is a new plan, the version number will be 0. If the plan exists, the version number will be one higher than the plan you loaded. Every time that you work with a PERTMASTER plan, the version number will be increased by one.

ENTERING PLAN ACTIVITIES

Your plan activities are entered in tabular form under the following headings:

LINE. The line numbers which appear in this column are for use as for screen reference points. They will always be numbered from 1 to 19, and do not form part of your plan. You do not type line numbers; they will be entered by the computer.

FROM. The activity numbers are entered in this column. As all activities have to be linked to succeeding activities, links are shown as going **FROM** an activity **TO** a succeeding activity in the next column. Each activity number must be an integer, or whole number, between 1 and the limit of activities for your computer. Press **◀RETURN▶** after entering the number. To enter a link from the last activity, simply press **◀RETURN▶**.

TO. The numbers that are entered in this column refer to succeeding links **FROM** the last activity shown **TO** a succeeding activity, as described in the preceding paragraph. This number must be an integer, or whole number, between 1 and the limit of activities for your computer. Press **◀RETURN▶** after entering the number.

DURATION. Duration is the best estimate of time it will take to complete the activity or link. The duration is entered as a number of sub-time units. For example, if you are working with a calendar of days, but have set your sub-time units to 3 in the plan headings, to indicate that you are working 3 shifts to a day, then the duration of each activity or link is entered in shifts. Durations must be an integer, or whole number, between 0 and 9999, and must be followed by a **◀RETURN▶**.

DESCRIPTION. Enter the description that you wish to use to describe the activity in this column, then press **◀RETURN▶**. The description may consist of up to 40 characters, and will be used on the reports.

Descriptions can take up a lot of memory. If your plan is large, and the activities have long descriptions, you can easily overload your computer's memory. To reduce the size of a description, you can use abbreviations. If the abbreviation is in the abbreviations file which was entered on the New Plan Menu, the full description will be printed out on the reports which PERTMASTER generates.

You must use an exclamation mark before your two-letter abbreviation to tell PERTMASTER that you are using an abbreviation. For example, if the abbreviation "RT" stands for "Repair and test", then the description

!RT gearbox assembly

would appear on the printed reports as

Repair and test gearbox assembly.

Since links do not have descriptions, the link type must be entered in the description column. PERTMASTER can process three types of links: finish-to-start, start-to-start, and finish-to-finish. After the duration of a link has been entered, you will be asked to enter the **LINK TYPE** as a description, using the following short-hand notation:

| <i>Link Type</i> | <i>Enter</i> |
|------------------|-----------------------|
| Finish-to-start | 1 or FS |
| Start-to-start | 2 or S |
| Finish-to-finish | 3 or FF |

The link type will then appear in the description column.

PERTMASTER displays a maximum of 19 lines on the screen. After you have entered 19 activities, the screen will clear and you will be able to continue.

WARNING: If frequent delays are encountered between pressing **◀RETURN▶** and the reappearance of the cursor, then you are approaching your computer's memory limit. Use more abbreviations, fewer activities, or fewer links to avoid this.

After you have entered the last activity or link in your plan, and the cursor is in the **FROM** column on the next line, you exit the entry mode by pressing **◀ESCAPE▶**. PERTMASTER will then display the first 19 lines of your plan; succeeding lines can be seen by pressing **◀RETURN▶**. You may now make changes, save your plan, or abandon your plan. Refer to Section 3.2.

SPECIAL FEATURES

Pressing **◀RETURN▶** for the duration will cause a zero duration to be entered. A zero duration is most often necessary with links.

You can enter activities in any sequence; they do not have to be in numeric sequence. It is good practice, however, to follow numeric sequence where possible, starting with low activity numbers, and working up to higher activity numbers as the plan progresses. Large deviations from this order will delay the analysis of the plan.

If you have made an error in the entry of a line, press **◀ESCAPE▶**. The whole of the line entry will be cleared, and the cursor will be repositioned in the **FROM** column. Then you can retype the line entry. This method can only be used while the cursor is still on the same line as the error. If it is not, use the delete command described in Section 3.2.

STARTS AND FINISHES

Every plan must have at least one start and at least one finish. However, you can use multiple starts and finishes on your networks.

A start in PERTMASTER is actually treated as a link from activity number 1. A finish is treated as a link to the highest activity that your computer will allow.

Both starts and finishes may be scheduled or unscheduled. An unscheduled start or finish simply means that it will occur as early as the plan will allow. A scheduled start means that the start can't happen before a specified day. A scheduled finish means that the finish must be completed by a specified day.

You can use these features on any activity, thereby forcing time constraints on any part of your plan.

To enter a start, type *S* in the **FROM** column and press ◀RETURN▶. The screen will clear, and a start will be displayed. The cursor will now be in the **TO** column, awaiting the entry of a link to the beginning of the plan. Type in the number of the activity to which you wish the start to be linked.

Now PERTMASTER will ask if the start is to be

SCHEDULED (Y/N)

If you type *N* (No), then this start is a simple unscheduled start, which will occur as early as possible (time now).

If you type *Y* (Yes), then this start is to be scheduled. PERTMASTER will then ask

NOT BEFORE DAY

which should be a day number (not a calendar date) on which the activity is to start. Enter the day number, and press ◀RETURN▶. The cursor will then move down one line and wait for the next link to be entered.

To enter a finish, type the number of the activity to which the finish is to be applied in the **FROM** column. Then type *F* in the **TO** column and press ◀RETURN▶. The word **FINISH** will be displayed.

At this stage PERTMASTER will ask if the finish is to be

SCHEDULED (Y/N)

If you type *N* (No), then this finish is a simple unscheduled finish, which will occur as early as the design of your network will allow.

If you type *Y* (Yes), then this finish is to be scheduled. PERTMASTER will then ask

NOT AFTER DAY

which should be the day number (not a calendar date) by which the activity is to finish. Enter the day number, and press ◀RETURN▶. The cursor will then move down one line and wait for the next activity to be entered.

Each start and finish counts as an extra activity towards the limit available on your computer.

If you wish to make a scheduled start or finish into an unscheduled one, type a day number of zero.

MILESTONES

Milestones are key dates within your project. They are selected to provide key information to a management level which requires brief information rather than detailed reporting. Milestone events must form part of your plan so that the timing can be calculated. PERTMASTER has a special Milestone Report, described in Section 4.1.1.

A milestone is an extra activity in your network. You can designate any number of milestones in your project. As a guide, between one activity in ten and one activity in twenty should be made milestones. This figure will depend on the type of reporting you need in your reports.

To enter a milestone, type the activity number in the **FROM** column, and press ◀RETURN▶. Then type *M* in the **TO** column and press ◀RETURN▶. The word **MILESTONE** will be printed on the screen.

The cursor will now move to the description column. (A milestone always has a zero duration, which is not displayed.) Type your description of the milestone, and press ◀RETURN▶. The cursor will then move down one line and wait for the next activity or link to be entered.

SELECTIVE REPORTING

You can design your descriptions to take advantage of the selective output reports. These reports will only contain those activities you specify as having a particular group of characters in some position in the description. Therefore you can use a character, or any group of characters, to indicate a management code, area reference, site code, etc., and tell PERTMASTER to print activities containing only that specific code.

For example, if you want reports covering only assembly operations, you could prefix the descriptions as follows:

- Assy — amplifier board
- Assy — chassis

You can then ask for a report using a selection key of *Assy* which always starts in the first position of the description.

Alternatively, you may specify the selection key in a random position in the description, where the descriptions might be:

- Amplifier board assembly
- Chassis assembly and wiring

In this case, if you specify a selection key of *assembly* in a random location, your report will include all activities in which the word “assembly” appears.

The selection key can include up to 38 characters. It may also be the abbreviation for a resource, in which case the report will include only those activities which utilize that resource. For additional information about selective output reports, see Section 4.1.1, 4.2.1, 4.5.1, or 4.6.1.1, as applicable.

RESOURCES

The use of resources and resource tracking is covered in Chapter 9 of the PERTMASTER User’s Guide. See Reference Section 3.2.1 for information on entering and changing resources.

CHANGING AN EXISTING PLAN

The facility which enables you to change a plan is accessed in either of two ways. If you have just created a new plan, you may make changes immediately after having entered the last activity of the plan. If you want to change an existing plan, you will have selected the plan name from the list of plans displayed, following your choice of option **1 (Produce an Up-to-Date Plan)** on the Main Menu.

In either case, PERTMASTER will display the first 19 lines of the plan with the query

COMMAND?

at the top of the screen. If you type a question mark, a list of the available commands will appear, as shown below.

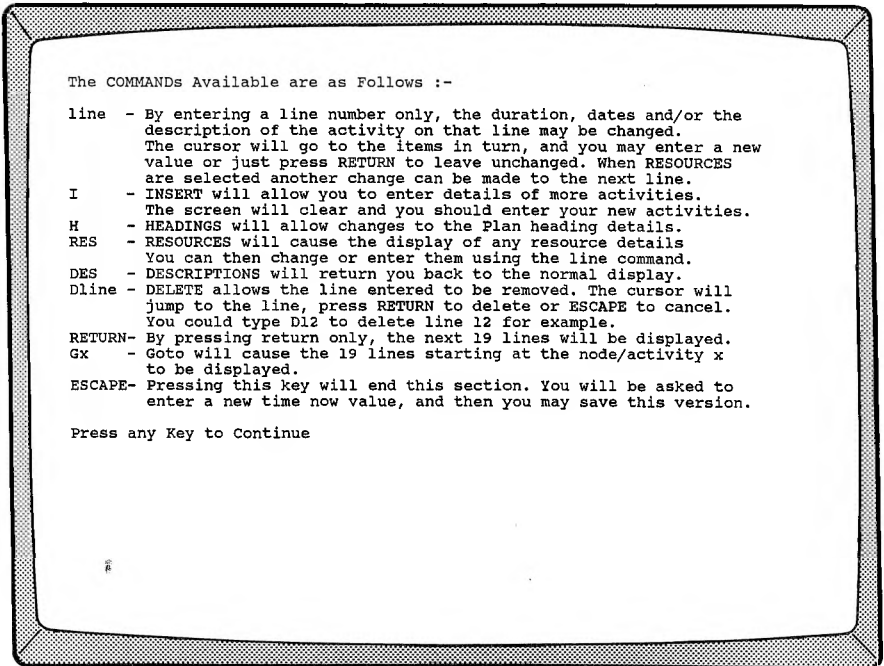

Although the methods of making changes to both Arrow and Precedence Plans are similar, there are subtle differences which must be observed.

1. **LINE (No.)**

A typical method of updating a plan on PERTMASTER is to change the duration of an activity or link (in Precedence Plans only) to reflect your latest estimate of the time that it will take to complete.

Simply enter the line number of the activity or link you wish to change. The cursor will move to the duration column of the line that you specify. You can enter a new duration, and then press ◀RETURN▶. If you decide not to change the duration, simply press ▶RETURN▶.

Then the cursor will move to the activity description or link type. You can change this, or simply press ▶RETURN▶ to leave it unchanged.

Node numbers (in Arrow Plans) and activity numbers and links (in Precedence Plans) cannot be changed by this method, since such action would destroy the logic of your plan. If you wish to change such data, you can insert or delete whole activities, as described in paragraphs 2 and 6, below.

2. **I (INSERT)**

If you wish to insert new activities, type *I* and press ▶RETURN▶. You will be transferred to the input format described in Section 3.1.1 for Arrow Plans and in Section 3.1.2 for Precedence Plans.

3. **H (HEADINGS)**

If you wish to change the plan headings, or any of the other plan parameters except the format, type *H* followed by ▶RETURN▶. The plan parameters will be shown in a display similar to the following.

Please Enter Any Changes To the Following Information :-

Plan File Identification (1 to 8 Letters): [PRODUCT]
Left Hand Report Title (Upto 30 Letters): Westminster Software Inc.
Centre Report Title (Upto 30 Letters): MARKETING A NEW PRODUCT
Right Hand Report Title (Upto 30 Letters): Palo Alto, California 94304
Calendar Code-Name (1 to 8 Letters): DAILY
Abbreviations Code-Name (1 to 8 Letters): ABBREV
Plan Format Type (A=Arrow, P=Precedence): PRECEDENCE
Time Units per Day (Numeric,Upto 3 digits): 1

NOTE : Press RETURN only to Skip Item, or to Leave it Unchanged
Press ESCAPE to Back Up One Step, or ? for HELP

This display is exactly the same as used when creating a plan, except that the parameters that apply to the plan being changed are shown also. Refer to Section 3.1.

Plan File Identification. You can change the name of a plan. If you do this the version number will also be reset to zero. There are two reasons why you might find this useful.

First, you can use this as a method of library networking. You might have a plan which describes your general needs. Rather than completely retype it, simply load it, change the name, and make necessary changes. The original plan will be left untouched. For example, you may have a plan which describes how to build a small bridge. Using this method, it will be possible to generate a plan quickly for building a specific bridge.

Second, if you have been working on many versions of a plan, the version number will get quite high. You may simply wish to reset the version number to zero and start again. Simply over type the name with the same name. This will reset the version number to zero.

Report Title(s). You can change any of the report titles within the limit of 30 characters each.

Calendar Code-Name. You can change the calendar name, and work with a different calendar. (You might wish to see the effect of working a six-day week instead of five days.)

Abbreviations Code-Name. You can change the abbreviations file.

Plan Format Type. You may NOT change the plan format. PERTMASTER follows different rules depending on the plan format. It cannot translate one plan format into another. Once you have created a plan in one format, it has to stay in that format.

Time Units per Day. You can change the sub-time units. For example, you may be working in days and wish to see the effect of working three shifts, rather than two shifts, a day. Remember that you may have to adjust the durations of some activities to reflect this change.

4. RES (RESOURCES) [See Section 3.2.1]

To enter or change resources, type *RES*.

5. DES (DESCRIPTIONS)

Type *DES* to return to the plan listing after you have displayed resources.

6. Dline (DELETE line)

If you wish to delete an activity or link, type *D* followed by the line number of the activity that you wish to delete. For example, type *D2* and press ◀RETURN▶ to delete the activity on line 2. The cursor will move to the left of the line that you indicate.

Pressing ◀RETURN▶ at this point will confirm the deletion. The screen will clear, and then redisplay 19 activities. The activity you deleted will have disappeared.

Pressing ◀ESCAPE▶ at this time will cancel the request to delete. Deletion by PERTMASTER is done in this two-stage manner to avoid losing valuable information by mistake.

NOTE: In Precedence Plans, if you delete a link, that link alone is deleted. If you delete an activity, the **ACTIVITY AND ALL PRECEDING AND SUCCEEDING LINKS** are removed.

7. RETURN

Press ◀RETURN▶ to view the next 19 lines of the displayed plan.

8. Gx (GO TO x)

If you wish to view a different part of the plan, type **G** followed by the Precedence Plan activity number or the Arrow Plan node number that you wish to see. PERTMASTER will then display 19 activities on the screen, starting with the number that you specified. For example, typing **G200** followed by **◀RETURN▶** will display the 19 activities following activity 200. To go to the beginning of any plan, type **G0**.

You will get a beep, indicating an error, if the activity or node you specify is larger than the largest activity or node of your network.

9. ESCAPE

To end making changes, type **◀ESCAPE▶**. PERTMASTER will ask you to

Enter a New Time Now Day Number

This is usually the day number that corresponds to today on your calendar. Type in this new number, or press **◀RETURN▶** to retain the previous number. You will be transferred to the Save/Abandon Plan Menu; refer to Section 3.2.2.

If you have typed **◀ESCAPE▶** by mistake, and wish to make more changes, type **◀ESCAPE▶** again. The first **◀ESCAPE▶** command will be cancelled.

ENTERING OR CHANGING RESOURCES

Resources are entered on a new plan or changed on an existing plan as part of PERTMASTER's change routine. In Section 3.2, the various commands used to change a plan were described. Included in these is the command **RES**, which is used to initiate entering or changing resources.

Identical procedures are used to enter or change resources in Arrow and Precedence Plans. You start by typing **RES** at the **COMMAND** line at the top of the screen, then press **◀RETURN▶**.

ENTERING RESOURCES ON A NEW PLAN

If you are working with a new plan, a display similar to the following will appear.

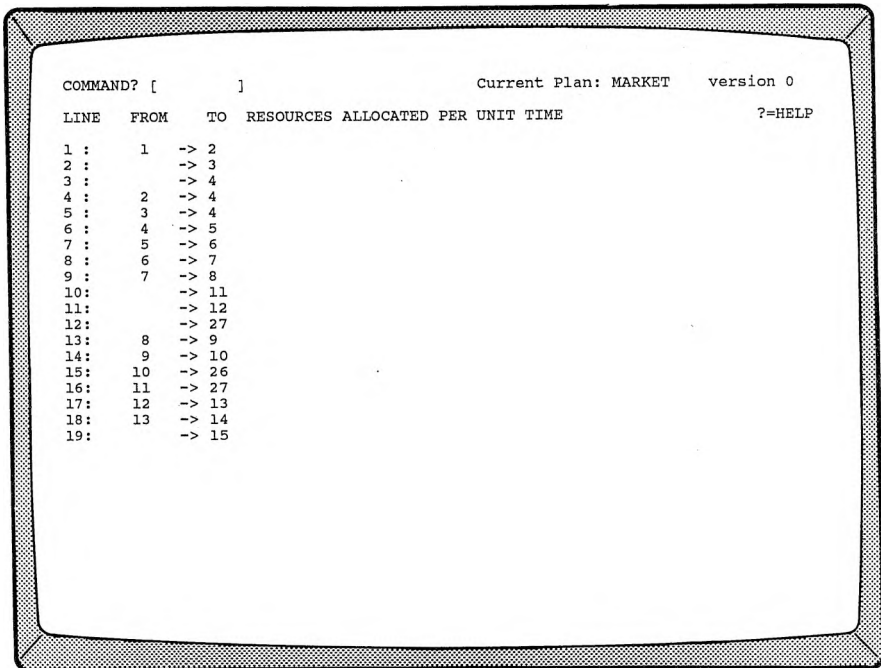

```
COMMAND? [      ]           Current Plan: MARKET   version 0
LINE  FROM   TO  RESOURCES ALLOCATED PER UNIT TIME           ?=HELP
1 :    1    ->  2
2 :          ->  3
3 :          ->  4
4 :    2    ->  4
5 :    3    ->  4
6 :    4    ->  5
7 :    5    ->  6
8 :    6    ->  7
9 :    7    ->  8
10:         -> 11
11:         -> 12
12:         -> 27
13:    8    ->  9
14:    9    -> 10
15:   10    -> 26
16:   11    -> 27
17:   12    -> 13
18:   13    -> 14
19:         -> 15
```

There will be a **LINE** number for each activity on your plan. If it is a Precedence Plan, the activity numbers will appear in the **FROM** column, and the **TO** column will be empty. Starts, finishes, links, and milestones will not be shown. These activities or events cannot have resources allocated to them.

If you are using an Arrow Plan, the start and finish node numbers will be in the **FROM** and **TO** columns, respectively. Likewise, starts, finishes, dummy activities, and milestones cannot have resources allocated to them, and are not shown.

To enter a resource, type the **LINE** number of the activity and press ◀RETURN▶. The cursor will move to the **RESOURCES ALLOCATED PER UNIT TIME** column on that line. Type the resource code (e.g. *LA5*) and press ◀RETURN▶. If there is more than one resource for the activity, simply type them one after the other (e.g. *LA5 BL2 \$P150*), then press ◀RETURN▶. The space between resource codes is not necessary, but is recommended since it improves legibility.

After each ◀RETURN▶, the cursor will move to the next line. To skip a line, simply press ◀RETURN▶ again. At line 19, pressing ◀RETURN▶ will move the cursor back to the **COMMAND** line at the top of the screen. If there are more activities on the plan, press ◀RETURN▶ to have the next nineteen displayed.

If you have finished entering resources, press ◀ESCAPE▶. PERTMASTER will ask you to

Enter a New Time Now Day Number

This is usually the day number that corresponds to today on your calendar. Type in this new number, or press ◀RETURN▶ to retain the previous number. You will be transferred to the Save/Abandon Plan Menu; refer to Section 3.2.2.

If you have typed ◀ESCAPE▶ by mistake, and wish to make more entries, type ◀ESCAPE▶ again. The first ◀ESCAPE▶ command will be cancelled.

CHANGING RESOURCES

Changing existing resources on a plan is accomplished in the same way as entering new resources, with one exception. When the cursor is at the line which you want to change, you just type over the old resource codes. If there is more than one resource on the line, and you want to alter only one of them, you must retype the entire line. PERTMASTER will save only that information to the left of the cursor.

TOO MANY RESOURCES?

If there is insufficient room on a line for you to enter all the resources you require on a given activity, you can create a parallel activity just to hold the remaining resources.

In an Arrow Plan, you will also require a dummy activity to avoid duplicating the start and finish nodes of your main activity. In a Precedence Plan, you should add a closely-linked activity — one linked to the main activity by both start-to-start and finish-to-finish links of zero duration.

SAVE/ABANDON PLAN MENU

After a new plan has been created or changes have been made to a plan, PERTMASTER will display the following menu.

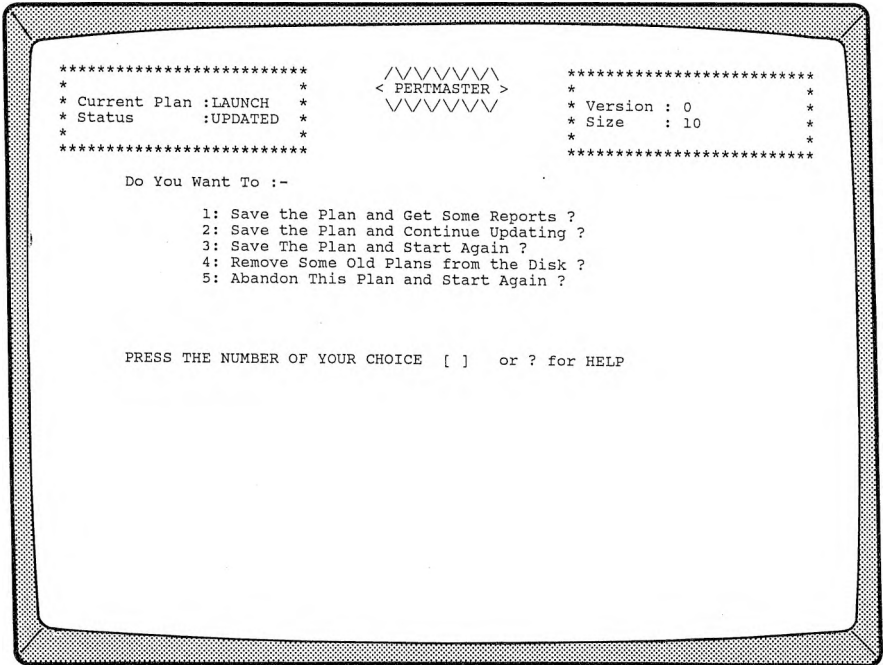

1. Save the Plan and Get Some Reports [See Section 4]

When option 1 is selected, the new or changed plan will be saved on your data disk and the Report Menu will be displayed.

2. Save the Plan and Continue Updating

Press 2 to get this option, which will save the plan onto the disk. You will then be returned to the listing of your plan where you can continue to change it.

This option should be used, when you are changing large plans, to guard against possible loss of the data which you have entered. It is advisable to save your plan periodically while working on it.

Each time that you use this feature, the version number will increase by one. You can therefore end up with a number of versions of your plan on the disk. Use option 4 of this menu to delete the unwanted versions.

3. **Save the Plan and Start Again**

Choose option **3** if you wish to save the plan and then start again. Your plan will be saved onto the disk, and you will be returned to the Main Menu.

4. **Remove Some Old Plans from the Disk**

If you wish to delete plans from your Data Disk, choose option **4**. This option is designed for use when the Data Disk is full, and there is no room on the disk to save the plan that you have just worked on.

When you choose this option, you will be presented with a list of the plans on the disk. To remove a plan, type the option number against that plan. PERTMASTER will then warn you that you are about to lose the plan, and will ask

Do You Want to Continue ?

If you type *N* (No), you will be returned to the Save/Abandon Plan Menu. If you type *Y* (Yes) the plan will be removed, and you will be asked

Do You Wish To Delete More Plans ?

If you type *N* (No), you will be returned to the Save/Abandon Plan Menu. If you type *Y* (Yes), the routine will be repeated.

If there are more plans on the disk than PERTMASTER can display on the screen, the last option on the screen will say **OTHER PLANS ON THIS DRIVE**. Choose this option to see the other plans.

If PERTMASTER can display all the plans that are on the data disk, the last option will read **NONE OF THESE**. Choose this option to return to the Save/Abandon Plan Menu.

5. **Abandon This Plan and Start Again**

Choose this option if you do not wish to save the plan you have been working on. PERTMASTER will warn you that you are about to lose your plan, and will ask

Do You Want To Continue ?

If you type *N* (No), the same menu will be redisplayed. If you type *Y* (Yes), the plan will be deleted, and PERTMASTER will return to the Main Menu.

GET REPORTS FROM AN UP-TO-DATE PLAN [Option 2 on Main Menu]

SAVE THE PLAN AND GET SOME REPORTS [Option 1 on Save/Abandon
Plan Menu]

This section of PERTMASTER prints reports from your plans. You can enter this section by choosing either of the options shown above.

When option **2** on the Main Menu is selected, you will be presented a list of plans on the disk. If PERTMASTER can display all the plans that are on the data disk, the last option will read **NONE OF THESE**. (This option returns you to the Main Menu.) If there are more plans on the disk than PERTMASTER can display on the screen, the last option on the screen will read **OTHER PLANS ON THIS DRIVE**. Choose this option to see the other plans.

If you type **F** before selecting a plan, the **FREE SPACE** (in bytes or characters) remaining in memory will be displayed. After you type the number of the plan from which you want reports, the Report Menu will appear.

If option **1** on the Save/Abandon Plan Menu is invoked, the list of plans will not appear, since you will already have been working with a plan. Instead, PERTMASTER will immediately display its Report Menu.

The Report Menu, shown on the following page, lists each type of report that can be generated. Options **1** through **5** are printed on the printer, while options **6** and **7** are printed to the monitor and data disk respectively.

NOTE: When PERTMASTER is used with certain computers, you may have to change the program disk before the Report Menu is displayed. Instructions will appear on the screen if this is the case.

- Unabbreviated description
- Earliest start time
- Latest start time
- Earliest finish time
- Latest finish time
- Duration
- Float time (with a marker on critical activities)

You may limit the activities listed in this report to certain ones which are selected, or to milestones.

2. Project or Period Barcharts [See Section 4.2]

Option **2** generates a horizontal barchart (or Gantt chart) which plots each activity against time. The **Project Barchart** covers the whole project from the start date. The **Period Barchart** covers the project from a selected start date.

Each type of barchart indicates critical activities, non critical activities, and float on non-critical activities. The last item is optional, depending on the choice made in setting up your system details (see Section 5.4).

3. List of Activities & Relationships

This report uses an unanalyzed copy of your plan to report on the logic. It allows you to determine that your plan is valid, and that you have entered the plan into the computer correctly.

Because this report requires an unanalyzed version of your plan, you should order this report first. (All other reports require a complete plan before they can be produced.) PERTMASTER will print this report first, before analyzing the plan for the other reports.

There are no options for this report. When selected, it will be identified as a **NETWORK LISTING** under **Reports Ordered So Far:** on the Report Menu. A typical report is shown in Chapter 10 of the User's Guide.

4. Complete Resources Report [See Section 4.3]

This tabular report gives the level of demand for all resources against a time scale. The resource requirements over a given time period are always shown. You can select the start date of the report.

5. Histogram for a Resource [See Section 4.4]

In addition to the tabular resources report described in paragraph 4, PERTMASTER provides a graphic interpretation for any resource

used in your plan. For a conventional resource, such as materials or labor, a histogram is produced. If a resource abbreviation starts with a "\$" or a "#" symbol, then the resource has been classified as expendable, in which case a cash-flow or S-curve will be generated instead of a histogram.

6. Screen Report [See Section 4.5]

This option enables you to produce three different reports on screen. They are similar to the Standard Report, Period Barchart, and Resource Histogram that you can obtain as printed reports.

The screen reports can be used to check the results of your plan before spending the time required to print reports on paper.

7. Disk Report [See Section 4.6]

The disk report will take the results of your plan and write them to a disk file. This will allow you to take information generated by PERTMASTER to another program.

8. Start or Cancel the Run

After you have selected all of the reports which you want printed, or if you decide not to print out any reports, type **8**. PERTMASTER will then ask you to

PRESS RETURN TO START THE RUN, ESC TO CANCEL

Pressing ◀RETURN▶ will start the printing process.

If you wish to abandon the printing of any particular report DURING the print run, press ◀ESCAPE▶. This will cause PERTMASTER to skip to the next report. Pressing the ◀ESCAPE▶ key may have no immediate effect, as some printers store a considerable number of characters in memory. These characters will be printed, regardless of interruption, until the memory is emptied, at which time the next report will start or the printing will terminate.

When the print run has finished, or if you press ◀ESCAPE▶, you will then be instructed to

**Please press Y if you want more reports
Press N if you do not**

If you press **Y** (Yes) you will be returned to the Report Menu. An **N** (No) will take you to the Main Menu.

STANDARD REPORT LISTING

[Option 1 on Report Menu]

The Standard Report is printed on the printer. Day numbers will be translated into calendar format. If PERTMASTER has been given a day number that is not within the given calendar range, it will print out the calendar day number (or time unit number) in parentheses. This method can be used to prepare reports on projects that do not use conventional calendar time periods such as days, weeks, months, etc. Typical reports are shown in Chapter 10 of the User's Guide.

When you select option **1** on the Report Menu, the following display will appear.

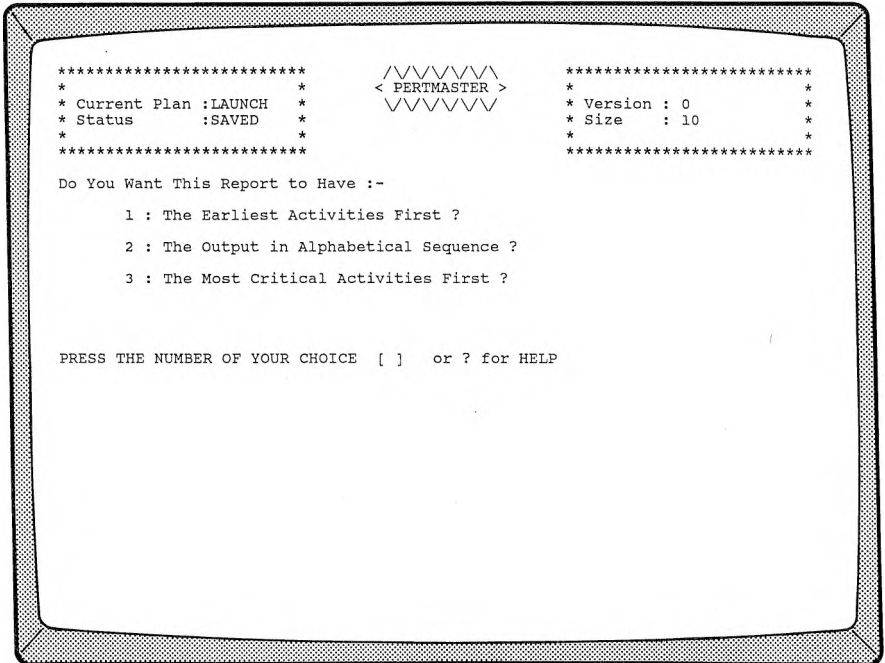

1. The Earliest Activities First

If you want the activities in your plan to appear in chronological order on the report, choose this option. The Selective Reporting Menu will then appear; refer to Section 4.1.1.

2. The Output in Alphabetical Sequence

Choosing this option will result in a report on which your activities will be listed in alphabetical order, as determined by your entries in the following menu.

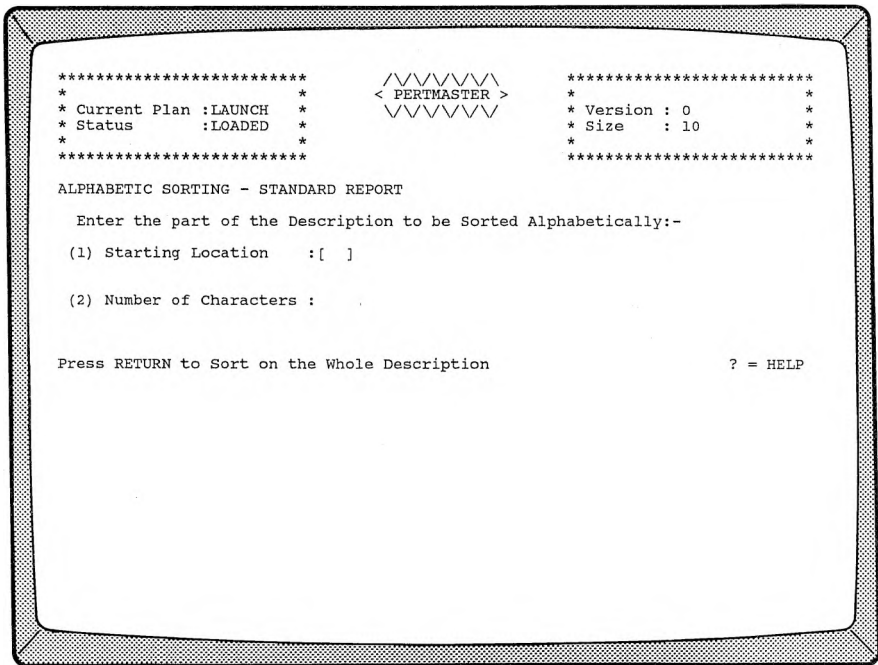

(1) Starting Location

This option allows you to select the position in the description on which the alphabetic sort is made. Type the number of the starting location, and press **<RETURN>**. If you simply press **<RETURN>**, a sort will be made on the entire description, and the Selective Reporting Menu will be displayed. Refer to Section 4.1.1.

(2) Number of Characters

If you have elected to designate a starting location, you must then enter the number of characters following that location that are to be sorted. When you have entered a number and a ◀RETURN▶, the Selective Reporting Menu will appear; refer to Section 4.1.1.

3. The Most Critical Activities First

Select option **3** if you want the most critical activities to appear at the beginning of the report. (Critical activities are those activities which establish the critical path through your plan.) After option **3** has been selected, the Selective Reporting Menu will appear; refer to Section 4.1.1.

SELECTIVE REPORTING MENU - STANDARD REPORT

When you have established the order in which the activities in your plan are to appear on the Standard Report, PERTMASTER will present the following menu.

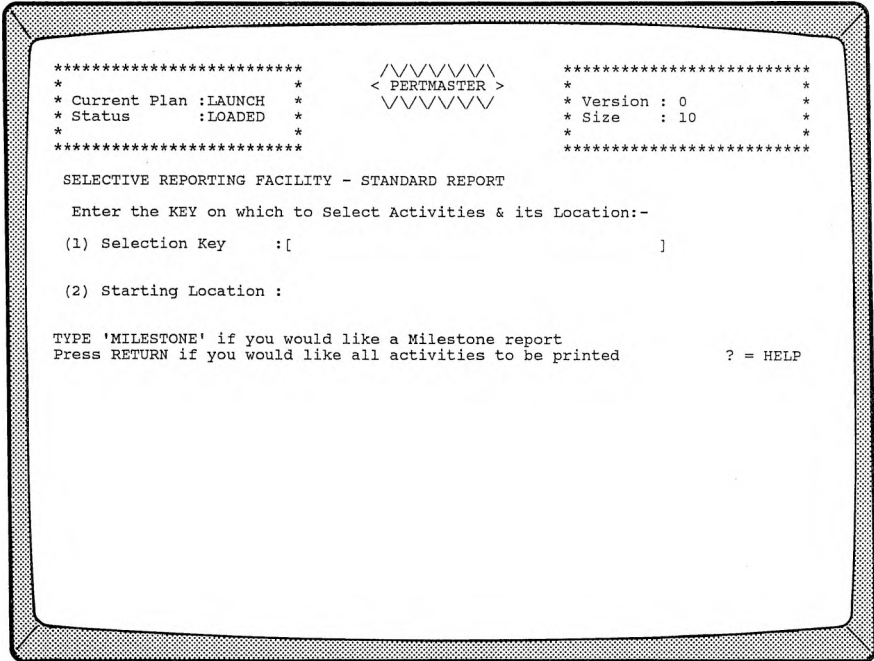

1. Selection Key

The selection key is a character, or group of characters (maximum of 38), which allows to you print out only selected activities. Refer to Section 3.1.1 or 3.1.2 for a more detailed explanation.

If you want all activities printed on the report, press ◀RETURN▶. If you want a Milestone Report, which will show only those activities which you have designated as milestones in your plan, type **MILESTONE** in capital letters, and press ◀RETURN▶. In either case, you will be returned to the Report Menu.

The report will be designated as a **STANDARD REPORT** or a **MILESTONE REPORT**, as appropriate to your choice, under **Reports Ordered So Far**. At that point you can have the report printed out immediately, request additional reports, or cancel the requirement.

NOTE: Node and activity numbers are never printed on the Milestone Report.

If you have used a selection key in your activity descriptions, and wish to limit the report to those activities, type the key characters, followed by a **◀RETURN▶**.

If you wish to exclude all activities above a certain float level, type **FLOAT** in capital letters, and press **◀RETURN▶**.

2. Starting Location

If you have entered a selection key, PERTMASTER requires a starting location. For a random location, i.e. anywhere in the description, press **◀RETURN▶**. If the starting location of the key is always in a fixed position, enter the appropriate number (e.g. *1* for the first letter in the description), and press **◀RETURN▶**. If your selection key is a resource, type *R*, and press **◀RETURN▶**.

If you have entered the word **FLOAT**, rather than a selection key, the second option on the above menu will have changed to

Maximum Float

at which point you must enter the float level. This will exclude all activities above that level from the report. If you are using sub-time units, the float level must be entered in sub-time units. Press **◀RETURN▶** after typing the float level.

Regardless of your choice, you will be returned to the Report Menu. At that point you can have the report printed out immediately, request additional reports, or cancel the requirement.

PROJECT OR PERIOD BARCHART

[Option 2 on Report Menu]

To produce a Project or Period Barchart on your printer, select option 2 on the Report Menu. Each type of barchart indicates critical activities, non-critical activities, and float. All non-working days are ignored in the barchart. Float is optional, depending on the choice made in setting up your system details (see Section 5.4). Typical barcharts appear in Chapter 10 of the User's Guide.

Selecting option 2 of the Report Menu results in the following display.

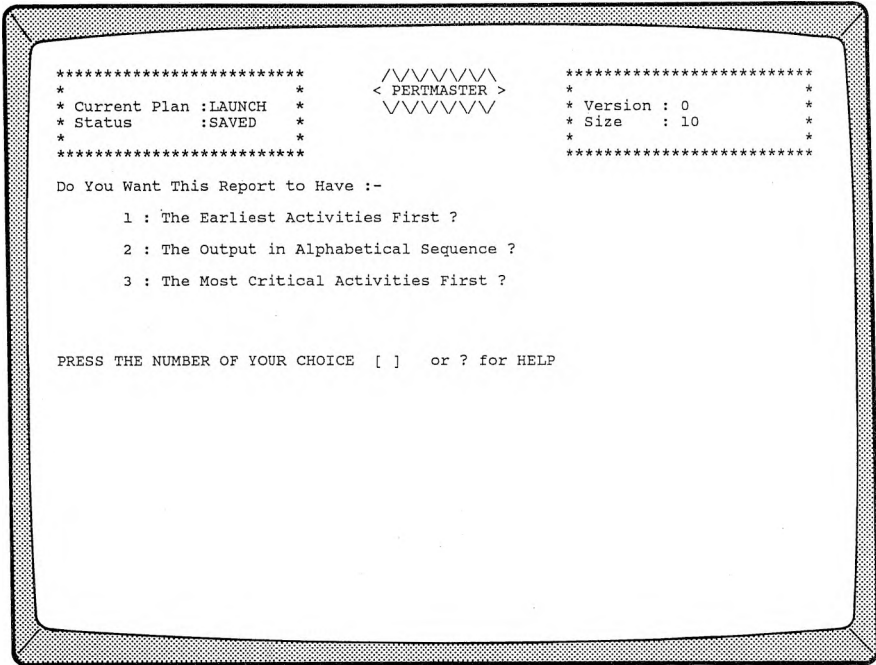

1. The Earliest Activities First

If you want the activities in your plan to appear in chronological order on the report, choose this option. The Selective Reporting Menu will then appear; refer to Section 4.2.1.

2. The Output in Alphabetical Sequence

Choosing this option will result in a report on which your activities will be listed in alphabetical order, as determined by your entries in the following menu.

```
*****
*                               *
* Current Plan :LAUNCH *
* Status      :LOADED *
*                               *
*****
< PERTMASTER >
*****
* Version : 0 *
* Size   : 10 *
*                               *
*****

ALPHABETIC SORTING - BARCHART REPORT

Enter the part of the Description to be Sorted Alphabetically:-

(1) Starting Location      :[ ]

(2) Number of Characters :

Press RETURN to Sort on the Whole Description          ? = HELP
```

(1) Starting Location

This option allows you to select the position in the description on which the alphabetic sort is made. Type the number of the starting location, and press ◀RETURN▶. If you simply press ◀RETURN▶, a sort will be made on the entire description, and the Selective Reporting Menu will be displayed. Refer to Section 4.2.1.

(2) Number of Characters

If you have elected to designate a starting location, you must then enter the number of characters following that location that are to be sorted. When you have entered a number and a **◀RETURN▶**, the Selective Reporting Menu will appear; refer to Section 4.2.1.

3. The Most Critical Activities First

Select option **3** if you want the most critical activities to appear at the beginning of the report. (Critical activities are those activities which establish the critical path through your plan.) After option **3** has been selected, the Selective Reporting Menu will appear; refer to Section 4.2.1.

SELECTIVE REPORTING MENU - BARCHART REPORT

When you have established the order in which the activities in your plan are to appear on the Barchart Report, PERTMASTER will present the following menu.

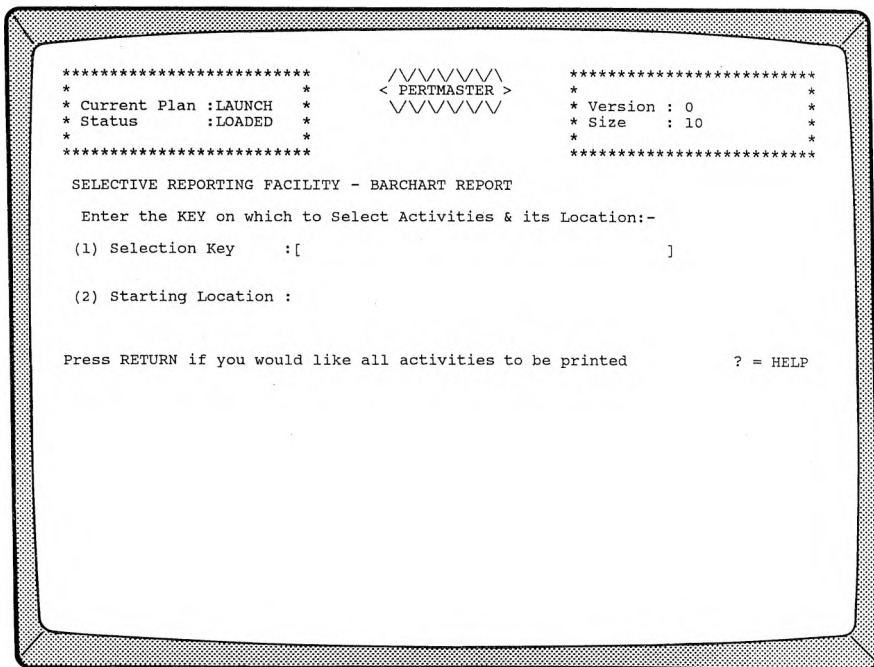

1. Selection Key

The selection key is a character, or group of characters (maximum of 38), which allows you print out only selected activities. Refer to Section 3.1.1 or 3.1.2 for a more detailed explanation.

If you want all activities printed on the report, press **◀RETURN▶**. The Barchart Report Menu will be displayed; see Section 4.2.2.

If you have used a selection key in your activity descriptions, and wish to limit the report to those activities, type the key characters, followed by a ◀RETURN▶.

If you wish to exclude all activities above a certain float level, type *FLOAT* in capital letters.

2. Starting Location

If you have entered a selection key, PERTMASTER requires a starting location. For a random location, i.e. anywhere in the description, press ◀RETURN▶. If the starting location of the key is always in a fixed position, enter the appropriate number (e.g. *1* for the first letter in the description). If your selection key is a resource, type *R*, and press ◀RETURN▶.

If you have entered the word *FLOAT*, rather than a selection key, the second option on the above menu will have changed to

Maximum Float

at which point you must enter the float level. This will exclude all activities above that level from the barchart. If you are using sub-time units, the float level must be entered in sub-time units. Press ◀RETURN▶ after typing the float level.

Following your last entry in the Selective Reporting Menu, PERTMASTER will display the Barchart Report Menu. See Section 4.2.2.

After you have entered all of your data in the Barchart Selective Reporting Menu, the following Barchart Report Menu will be displayed.

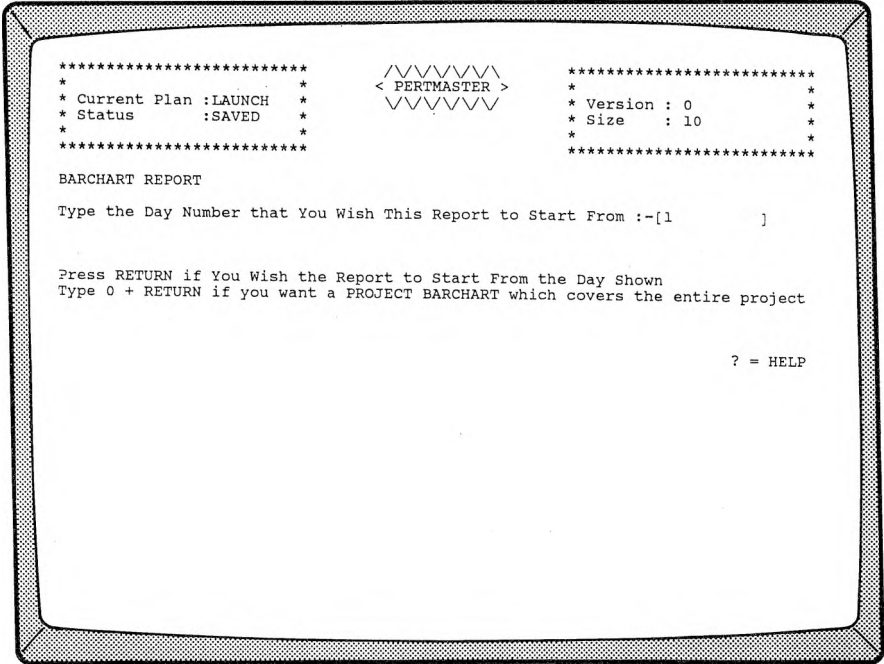

The day number shown, and at which the cursor will be positioned, is the current start day of your plan.

Typical barcharts are shown in Chapter 10 of the User's Guide. The bars are made up of the following characters:

- CCCCCCCCCCC** represents critical activities
- =====** represents non-critical activities
-** represents float on non-critical activities
- NNNNNNNNNN** represents negative float

NOTE: Float need not be shown, as determined in setting up your system details; see Section 5.4.

The Period Barchart will be printed out on your printer so that it starts at the designated day and finishes at the right side of the page. The Project Barchart may require several pages of printing, depending on the length of your plan calendar. These pages can be pasted or taped together to form a continuous chart.

If you want a Project Barchart, which covers your entire plan, type *0* and press ◀RETURN▶. This barchart will be printed so that each unit of time for your plan occupies one print position. Instructions for compressing the barchart are given below.

If you want a Period Barchart, which will start at the day of your choice, you have two options. To start the barchart at the day number shown, simply press ◀RETURN▶. Otherwise type the day number at which you want the barchart to start, and press ◀RETURN▶. You may also compress the barchart, as follows.

If you wish to compress either type of barchart, you may enter a number which tells PERTMASTER to use that number of time units for each print position. This is done by typing the number, enclosed in parentheses, after the starting day number (or after *0* for a Project Barchart) and before pressing ◀RETURN▶. For example, if the report is to start at day *10* and you want the report printed out using two time units per print position, type *10(2)* and press ◀RETURN▶. This will halve the length of the barchart.

PERTMASTER will automatically adjust the barchart length to fit onto one width of paper if you use a zero inside the parentheses, e.g. *10(0)*.

After you have specified the type of barchart, you will be returned to the Report Menu. At that point you can have the report printed out immediately, request additional reports, or cancel the requirement.

COMPLETE RESOURCES REPORT

[Option 4 on Report Menu]

This report is printed out in tabular form and gives the level of demand for all resources against a time scale. A typical report is included in Chapter 10.

PERTMASTER will display the following menu when option 4 is chosen.

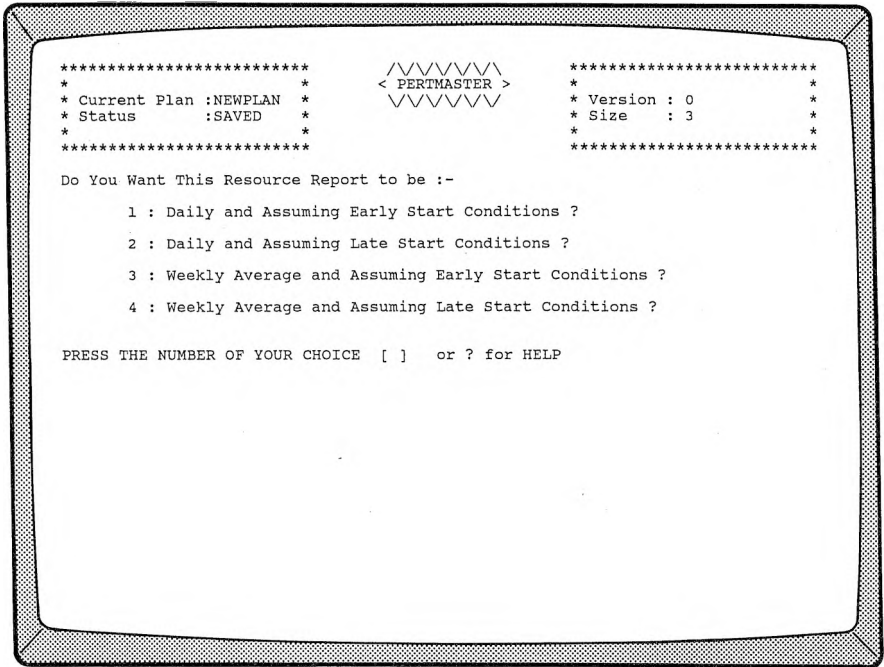

1. Daily and Assuming Early Start Conditions

This option generates a report by days, assuming that all activities start as early as possible.

2. **Daily and Assuming Late Start Conditions**

Option **2** produces a report by days, assuming that all activities start as late as possible.

3. **Weekly Average and Assuming Early Start Conditions**

This report averages the daily requirement of resources over a weekly period, assuming that all activities start as early as possible.

4. **Weekly Average and Assuming Late Start Conditions**

Option **4** provides a report which averages the daily requirement of resources over a weekly period, assuming that all activities start as late as possible.

After making a choice, you will be asked to

Please Type the Day Number that You Wish This Report to Start From

Press **◀RETURN▶** if you want the report to start with the day shown. Otherwise, type a day number between *1* and *999*, and press **◀RETURN▶**. You will be returned to the Report Menu, where **RESOURCE REPORT** will be listed under **Reports Ordered So Far:**. At that point you can have the report printed out immediately, request additional reports, or cancel the requirement.

Note that all activities are not likely to start early or late in any particular project. Therefore, comparison of an early- and late-start resources report will give an indication of the effect of float on the demand for resources.

HISTOGRAM FOR A RESOURCE

[Option 5 on Report Menu]

Option 5 on the Report Menu can provide two types of printed reports covering resources used in your plan. A conventional histogram is produced for a conventional resources (e.g. labor, equipment, etc.) and for point resources (which start with a “#”), such as payments to suppliers. Expendable resources, which start with a “\$”, will generate a cash-flow, or S, curve. Both are plotted against day numbers and calendar dates. See Chapter 10 of the User’s Guide for examples of these reports.

Although resource quantities entered in a plan may be fractional, they will be rounded to the closest integer on the printed report.

Selecting option 5 results in the following display.

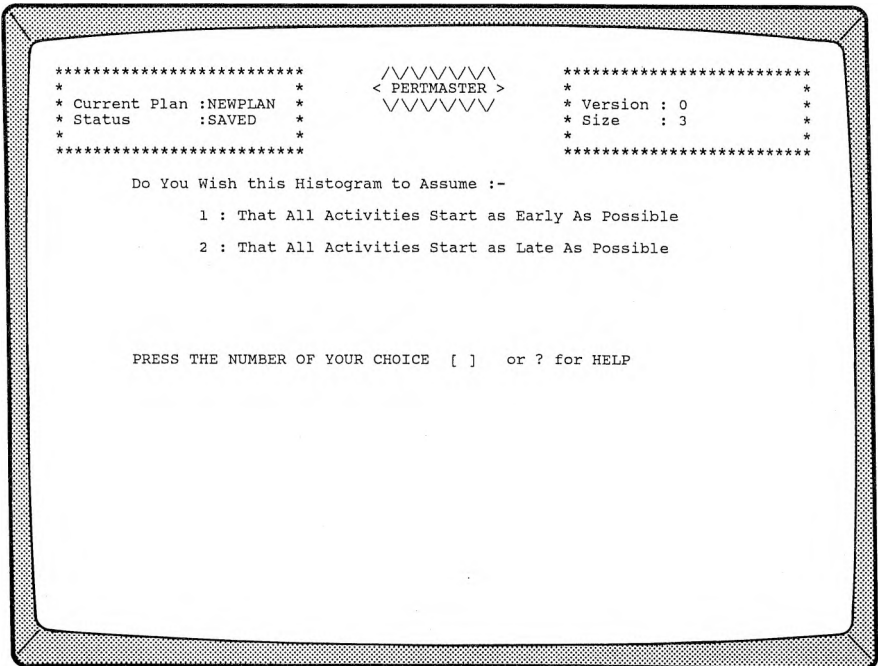

1. That All Activities Start as Early As Possible

This option generates a report by days, assuming that all activities start as early as possible.

2. That All Activities Start as Late As Possible

Option 2 produces a report by days, assuming that all activities start as late as possible.

After making a choice, you will be asked to

Please Type the Day Number that You Wish This Report to Start From

Press ◀RETURN▶ if you want the report to start with the day shown. Otherwise, type a day number between 1 and 999, and press ◀RETURN▶. A comparison of the differences between two histograms drawn with different assumptions on the same resource will show the effect of float on your plan.

Next, PERTMASTER will ask you to

Please type the 2 Character Abbreviation of the Resource to be Analysed in this Report

At this time you enter the two-character abbreviation for the resource to be analyzed, followed by a ◀RETURN▶. Normally, the histogram or cash-flow curve will be scaled automatically to fit a single sheet of paper. However, you can set the scaling of the graph manually if you enter the top and bottom values of the graph in parentheses following the resource code you specify. For example, entering

\$E(1000,50)

would produce a cash-flow curve of resource \$E with the bottom of the graph at 50 units, and the top of the graph at 1000 units.

PERTMASTER can also provide a report from multiple resources under certain conditions. If the initial character in each resource code is the same, the resources will be summed when you enter a resource code like A=. In that case, the report will be the total of all resources whose codes start with "A." In computing terms, the equal sign is a "wildcard." As an example, if "\$L" represented labor costs, "\$M" material costs, and "\$T" travel costs, entering a resource code of \$= would provide a total cash-flow curve.

After entering your resource, you will be returned to the Report Menu, where either type of report will be listed as a **HISTOGRAM** under **Reports**

Ordered So Far: At that point you can have the report printed out immediately, request additional reports, or cancel the requirement.

The report will be printed on a single sheet of paper, with time scaled automatically as a function of the number of characters per line specified for your printer. (Refer to Section 5.3.) The time scale will start at the start date that you select, and will end at a date which depends on the width of your printer.

If you require a histogram for a date which is later than this end date, simply request another Histogram For a Resource with a later start date.

SCREEN REPORT

[Option 6 on Report Menu]

Selecting option **6** on the Report Menu enables you to obtain screen reports which are similar to the Standard Report, the Period Barchart, and the Resource Histogram. The following menu will be displayed.

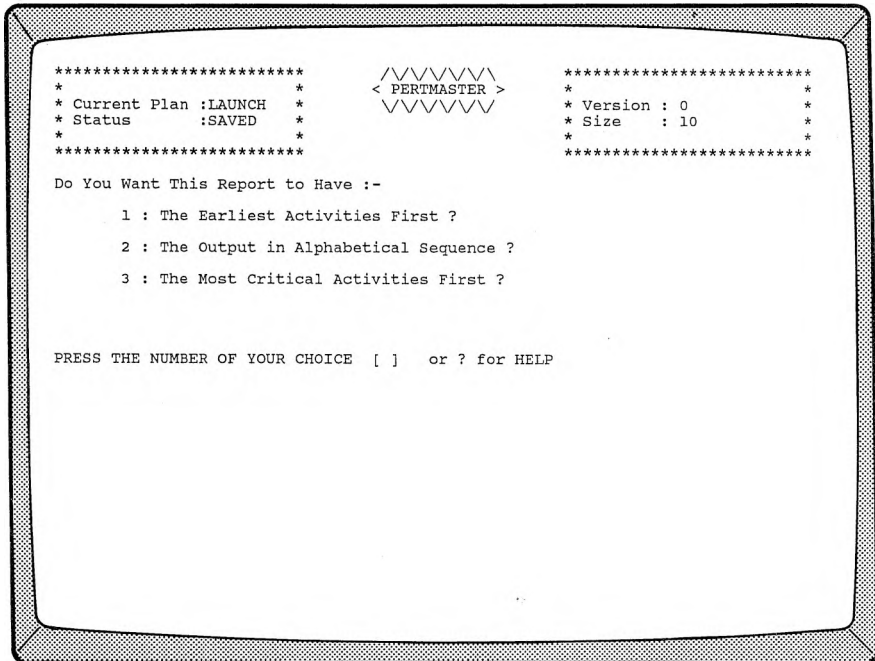

1. The Earliest Activities First

If you want the activities in your plan to appear in chronological order on the report, choose this option. The Selective Reporting Menu will then appear; refer to Section 4.5.1.

(2) Number of Characters

If you have elected to designate a starting location, you must then enter the number of characters following that location that are to be sorted. When you have entered a number and a **◀RETURN▶**, the Selective Reporting Menu will appear; refer to Section 4.5.1.

3. The Most Critical Activities First

Select option 3 if you want the most critical activities to appear at the beginning of the report. (Critical activities are those activities which establish the critical path through your plan.) After option **3** has been selected, the Selective Reporting Menu will appear; refer to Section 4.5.1.

SELECTIVE REPORTING MENU - SCREEN REPORT

When you have established the order in which the activities in your plan are to appear on the Screen Report, PERTMASTER will present the following menu.

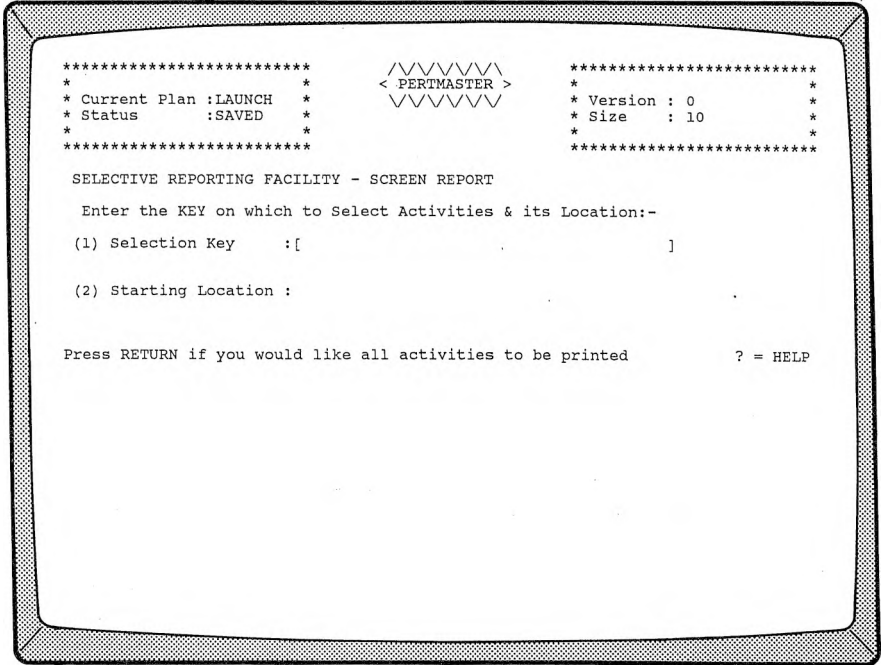

1. Selection Key

The selection key is a character, or group of characters (maximum of 38), which allows you print out only selected activities. Refer to Section 3.1.1 or 3.1.2 for a more detailed explanation.

If you want all activities printed on the report, press ◀RETURN▶. You will be returned to the Report Menu, where **SCREEN REPORT** will appear listed under **Reports Ordered So Far:**. At that point you

can have the report printed out immediately, request additional reports, or cancel the requirement.

If you have used a selection key in your activity descriptions, and wish to limit the report to those activities, type the key characters, followed by ◀RETURN▶.

If you wish to exclude all activities above a certain float level, type *FLOAT* in capital letters, and press ◀RETURN▶.

2. Starting Location

If you have entered a selection key, PERTMASTER requires a starting location. For a random location, i.e. anywhere in the description, press ◀RETURN▶. If the starting location of the key is always in a fixed position, enter the appropriate number (e.g. 0 for the first letter in the description). If your selection key is a resource, type *R*, and press ◀RETURN▶.

If you have entered the word *FLOAT*, rather than a selection key, the second option on the above menu will have changed to

Maximum Float

at which point you must enter the float level. This will exclude all activities above that level from the barchart. If you are using sub-time units, the float level must be entered in sub-time units. Press ◀RETURN▶ after typing the float level.

Regardless of your choice, you will be returned to the Report Menu. At that point you can have the report printed out immediately, request additional reports, or cancel the requirement.

When you elect to have the Screen Report printed, a Screen Barchart similar to that shown in Chapter 10 will appear on your screen. At that time, you may change the display; refer to Section 4.5.2.

COMMANDS

After the Screen Barchart is shown, you have several options, as indicated in the following Help Menu.

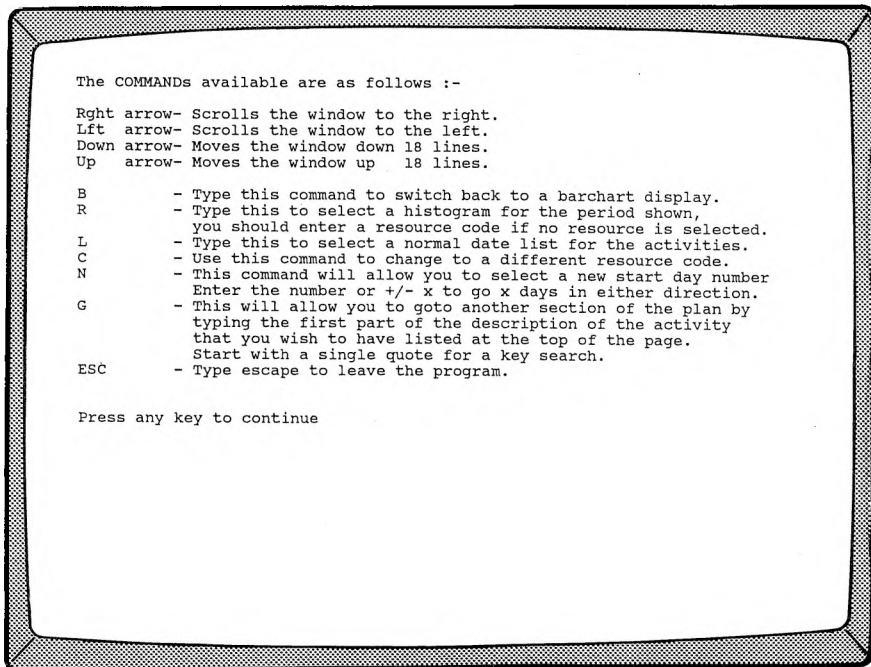

NOTE: The first four commands may use the letter command OR the arrow key indicated for each, depending on the computer which is being used.

D or Right arrow scrolls the report window to the right, setting an earlier starting date for the report (if possible).

S or Lft arrow scrolls the report window to the left, setting a later starting date for the report (if possible).

- X or Down arrow** shows the next 18 lines of the Screen Barchart or Screen List Report.
- E or Up arrow** shows the previous 18 lines of the Screen Barchart or Screen List Report.
- B** switches the display back to a Screen Barchart if a Screen Histogram or Screen List is shown.
NOTE: Exiting the Help Menu always returns to a Screen Barchart
- R** changes the Screen Report to a Screen Histogram, similar to the printed Resource Histogram. PERTMASTER will then ask you to

Enter Resource Code

at which point you must enter the two-letter abbreviation for the resource, then press **◀RETURN▶**. Only conventional resources may be entered; resources starting with "\$" or "#" symbols will be rejected. A typical Screen Histogram is shown in Chapter 10 of the User's Guide.

If you previously selected a Screen Histogram, you would not be asked to choose a resource at this time. The histogram for the previous resource would be redisplayed. To change the resource, use the C-command.

- L** changes the screen report to a Screen List report, similar to the printed Standard Report. A typical Screen List is shown in Chapter 10 of the User's Guide.
- C** allows you to change the resource code, as described above for the R-command. If you press **◀RETURN▶** after you type *C*, the next resource in the abbreviations file will be displayed.

N allows you to select a new start day number. Enter the new day number or enter $+x$ or $-x$ to go x days in either direction.

G allows you to go to another section of your plan. PERTMASTER will respond with

Goto Activity ?

You may then type the first part of any activity description to move that activity to the top of the display. Activity and node numbers, when shown, are considered part of the description. (The part that you type must identify that activity uniquely. For example, *Del* would not be unique if the plan included “Deliver” and “Delete” as the first words of activities.) If you wish to search for a key word in a description, prefix the word with an apostrophe (e.g. *'Roof*). Press ◀RETURN▶ after typing your entry.

If you type *G* and then simply press ◀RETURN▶, the first activities in your plan will be displayed.

ESC Press ◀ESCAPE▶ to leave the screen report section. PERTMASTER will permit you to request additional reports or to return to the Main Menu.

Pressing ◀RETURN▶ will display the Barchart Key used on the Screen Barchart. A second ◀RETURN▶ causes the Screen Barchart to be redisplayed.

If you type *F* while the cursor is at the command line, the free space (in bytes or characters) remaining in memory will be shown on the command line.

SCREEN LIST

The Screen Barchart provides you with a good overall picture of your project. However, it is difficult to read the exact start and finish dates of activities. The Screen List, obtained by using the L-command, will clarify the Screen Barchart.

Critical activities will be shown with zero **FLOAT** and with identical **EARLY START** and **LATE START** dates. **FLOAT** will be shown for non-critical activities, with **EARLY START** and **LATE START** dates which differ by the number of time units equal to the **FLOAT**.

Negative float is indicated by a negative number under **LATE START**. All other activities will be shown with positive float.

SCREEN HISTOGRAM

The Screen Histogram is useful for many purposes. As a prime example, if it shows that a particular trade or labor skill is overloaded, you can adjust your plan to remove this overload. The scaling is automatic on the Screen Histogram, and cannot be set by the user.

Note that the Screen Histogram uses the same date scale as the Screen Barchart. Thus, you can easily identify the tasks in the barchart which call for the resource on the histogram.

Screen Histograms are produced only for conventional resources. PERTMASTER will reject a request for a Screen Histogram of an expendable or point resource.

Although fractional resource quantities may be entered in a plan, they will be rounded to the closest integer on the Screen Histogram.

If this option is selected, you will be returned to the Report Menu, where **DISK REPORT** will be listed under **Reports Ordered So Far**.

At that point you can have the report written immediately, request additional reports, or cancel the requirement. Refer to Section 4.6.2 for details of the report format.

3. **A Late Start Resources Report**

Option **3** generates a report which provides the demand for resources on a daily basis, assuming that all activities start as late as possible. If this option is selected, you will be returned to the Report Menu, where **DISK REPORT** will be listed under **Reports Ordered So Far**.

At that point you can have the report written immediately, request additional reports, or cancel the requirement. Refer to Section 4.6.2 for details of the report format.

TIME ANALYSIS REPORT

[Option 1 on Disk Report Menu]

When option 1 on the Disk Report Menu is selected, the following menu will be displayed.

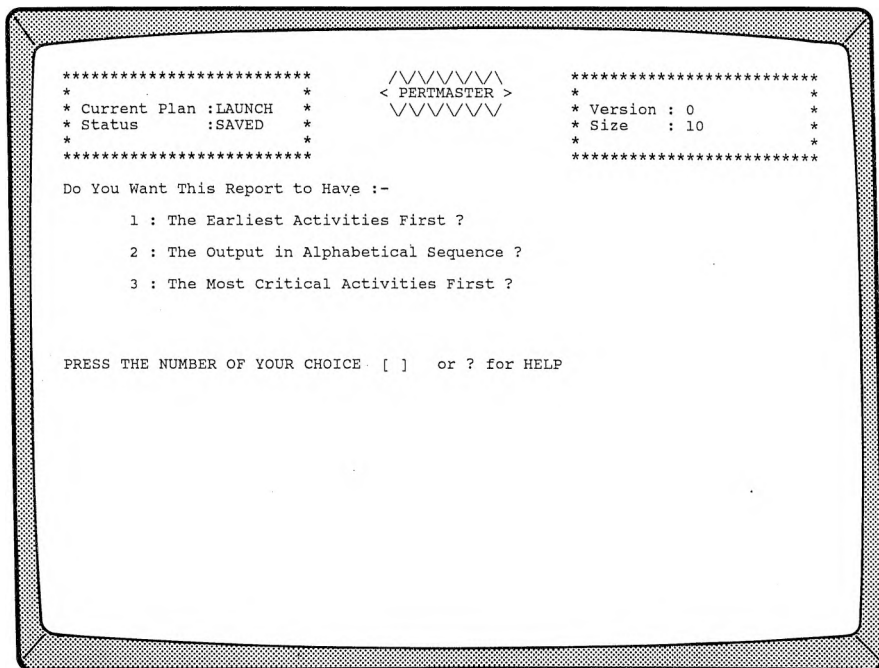

1. The Earliest Activities First

If you want the activities in your plan to appear in chronological order on the report, choose this option. The Selective Reporting Menu will then appear; refer to Section 4.6.1.2.

2. The Output in Alphabetical Sequence

Choosing this option will result in a report on which your activities will be listed in alphabetical order, as determined by your entries in the following menu.

```
*****
* Current Plan :LAUNCH *
* Status       :LOADED *
*****
```

```
  \V\V\V\V\V\
 < PERTMASTER >
  /V/V/V/V/V/
```

```
*****
* Version : 0 *
* Size   : 10 *
*****
```

ALPHABETIC SORTING - DISK REPORT

Enter the part of the Description to be Sorted Alphabetically:-

(1) Starting Location :[]

(2) Number of Characters :

Press RETURN to Sort on the Whole Description

? = HELP

(1) Starting Location

This option allows you to select the position in the description on which the alphabetic sort is made. Type the number of the starting location, and press ◀RETURN▶. If you simply press ▶RETURN▶, a sort will be made on the entire description, and the Selective Reporting Menu will be displayed. Refer to Section 4.6.1.1.

(2) Number of Characters

If you have elected to designate a starting location, you must then enter the number of characters following that location that are to be sorted. When you have entered a number and a ▶RETURN▶, the Selective Reporting Menu will appear; refer to Section 4.6.1.1.

3. The Most Critical Activities First

Select option **3** if you want the most critical activities to appear at the beginning of the report. (Critical activities are those activities which establish the critical path through your plan.) After option **3** has been selected, the Selective Reporting Menu will appear; refer to Section 4.6.1.1.

SELECTIVE REPORTING MENU - DISK REPORT

When you have established the order in which the activities in your plan are to appear in the Time Analysis Report, PERTMASTER will present the following menu.

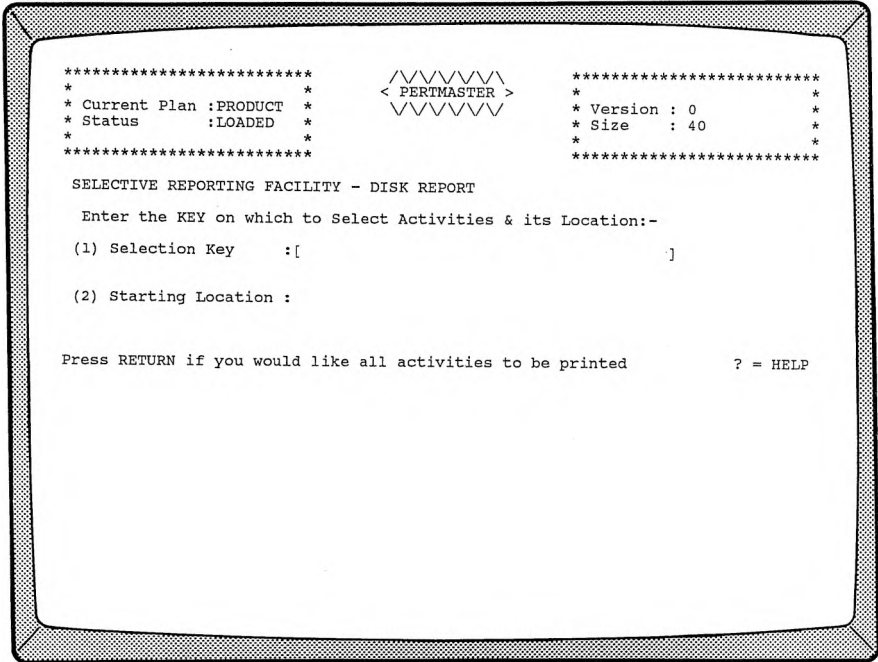

1. Selection Key

The selection key is a character, or group of characters (maximum of 38), which allows you print out only selected activities. Refer to Section 3.1.1 or 3.1.2 for a more detailed explanation.

If you want all activities printed on the report, press **◀RETURN▶**. You will be returned to the Report Menu, where **DISK REPORT** will appear listed under **Reports Ordered So Far:**. At that point you can

have the report written immediately, request additional reports, or cancel the requirement.

If you have used a selection key in your activity descriptions, and wish to limit the report to those activities, type the key characters, followed by a ◀RETURN▶.

If you wish to exclude all activities above a certain float level, type **FLOAT** in capital letters, and press ◀RETURN▶.

2. Starting Location

If you have entered a selection key, PERTMASTER requires a starting location. For a random location, i.e. anywhere in the description, press ◀RETURN▶. If the starting location of the key is always in a fixed position, enter the appropriate number (e.g. *1* for the first letter in the description) and a ◀RETURN▶. If your selection key is a resource, type *R*, and press ◀RETURN▶.

If you have entered the word **FLOAT**, rather than a selection key, the second option on the above menu will have changed to

Maximum Float

at which point you must enter the float level. This will exclude all activities above that level from the barchart. If you are using sub-time units, the float level must be entered in sub-time units. Press ◀RETURN▶ after typing the float level. Regardless of your choice, you will be returned to the Report Menu. At that point you can have the report written immediately, request additional reports, or cancel the requirement.

The Time Analysis Report file name will consist of the first seven letters of your plan name, prefaced by a "T". The version number of your plan will be appended to this name as the extension. For example, if your plan is called "PLANNAME", and you are working with Version 2, the disk file that you will generate from this plan will be "TPLANNAM.2".

All data are written using ASCII codes, which are the standard characters by which all microcomputers read such data. Each numeric value and data string (series of ASCII characters) is placed in a separate field. Fields are separated by commas; data strings are enclosed in quotes.

As shown in the printout reproduced at the end of this section, the file will consist of one line of heading information, followed by the main report. The information relating to each activity will be stored on a separate line.

The heading information line will contain:

- Plan name
- Version number
- Left report title
- Center report title
- Right report title
- Report date
- Report day number
- Calendar file name
- Abbreviations file name

Each line containing information relating to an activity will consist of:

- Activity description
- Early start date
- Early start day number
- Early finish date
- Early finish day number
- Late start date
- Late start day number
- Late finish date
- Late finish day number
- Duration
- Float

The following is a printout of a typical time analysis report.

A TIME ANALYSIS DISK REPORT - FIRST ACTIVITIES ONLY

"HOUSE " ,0,"Acme Construction Corp.," "Downtown Oakland","New Housing Estate", "12/JUL/84",9,"DAY","ANC", " ,0,0
"10-12 Clear Site", "12/JUL/84",9, "17/JUL/84",12, "12/JUL/84",9, "17/JUL/84",12,4,0
"10-32 Deliver Windows", "12/JUL/84",9, "31/JUL/84",22, "15/AUG/84",33, "3/SEP/84",46,14,24
"10-35 Deliver Roofing", "12/JUL/84",9, "27/JUL/84",20, "30/AUG/84",44, "14/SEP/84",55,12,35
"12-14 Excavate for Drains", "18/JUL/84",13, "23/JUL/84",16, "31/JUL/84",22, "3/AUG/84",25,4,9
"12-16 Prepare Foundations", "18/JUL/84",13, "20/JUL/84",15, "18/JUL/84",13, "20/JUL/84",15,3,0
"12-20 Drain connections", "18/JUL/84",13, "23/JUL/84",16, "2/AUG/84",24, "7/AUG/84",27,4,11
"14-20 Construct Drains", "24/JUL/84",17, "25/JUL/84",18, "6/AUG/84",26, "7/AUG/84",27,2,9
"16-18 Prepare and Cast Concrete Foun", "23/JUL/84",16, "24/JUL/84",17, "23/JUL/84",16, "24/JUL/84",17,2,0
"18-20 Underground Walls", "25/JUL/84",18, "7/AUG/84",27, "25/JUL/84",18, "7/AUG/84",27,10,0
"20-24 Prepare and Cast Concrete Floor", "8/AUG/84",28, "10/AUG/84",30, "8/AUG/84",28, "10/AUG/84",30,3,0
"24-26 Start Walls 1-2", "13/AUG/84",31, "16/AUG/84",34, "13/AUG/84",31, "16/AUG/84",34,4,0
"24-30 Access Scaffold", "13/AUG/84",31, "20/AUG/84",36, "21/AUG/84",37, "28/AUG/84",42,6,6
"26-28 Finish Walls 1-2", "17/AUG/84",35, "22/AUG/84",38, "17/AUG/84",35, "22/AUG/84",38,4,0
"26-32 Build Service Duct", "17/AUG/84",35, "21/AUG/84",37, "30/AUG/84",44, "3/SEP/84",46,3,9

The Resources Report file name will consist of the first seven letters of your plan name, prefaced by an "E" if it is an Early Start Resources Report, or by an "L" if it is a Late Start Resources Report. In either case, the version number of your plan will be appended to the name as an extension. For example, if your plan is called "PLANNAME", and you are working with Version 2, the Early Start Resources Report disk file generated from this plan will be "EPLANNAM.2". A Late Start Resources Report file will be named "LPLANNAM.2".

All data are written using ASCII codes, which are the standard characters by which all microcomputers read such data. Each numeric value and data string (series of ASCII characters) is placed in a separate field. Fields are separated by commas; data strings are enclosed in quotes.

As shown in the printout reproduced at the end of this section, the file will consist of one line of heading information, followed by the main report. The information relating to each activity will be stored on a separate line.

The heading information line will contain:

- Plan name
- Version number
- Left report title
- Center report title
- Right report title
- Report date
- Report day number
- Calendar file name
- Abbreviations file name

Each line containing information relating to an activity will consist of:

- Date
 - Day number
 - Resource code
 - Resource quantity
- } repeated for all resources used

- 1. Work with Calendars** [See Section 5.1]
A calendar must be set up before any program plan can be established. The calendar defines the time scale and work days on which the plan is based.
- 2. Work with Abbreviations Dictionaries** [See Section 5.2]
An abbreviations dictionary must be set up before any program plan can be established.
PERTMASTER uses abbreviations for two reasons. First, the use of abbreviations saves computer memory, which allows you to work with larger networks than would otherwise be possible with your system. Second, PERTMASTER requires you to use abbreviations for your resource categories, used in the resource list of each activity.
A direct benefit of using abbreviations is the reduction in typing time required to enter your data.
- 3. Change Printer Details** [See Section 5.3]
Your printer must be set up to work with your computer before you load PERTMASTER. Thereafter, only certain format details may be changed within the program.
- 4. Change other System Details** [See Section 5.4]
Other system details involve certain report features and selecting the disk drive for your plans.
- 5. Delete old Plans from a Disk** [See Section 5.5]
Plans which are no longer being used can be deleted to increase available disk space.
- 6. Copy Plans from One Disk to Another Disk** [See Section 5.6]
This option allows you to copy plans within PERTMASTER.
- 7. Merge Plans Together** [See Section 5.7]
Option 7 permits you to merge two or more plans into a larger plan and to renumber a plan.
- 8. Do None of These**
Returns you to the Main Menu.

3. Delete an Existing Calendar File

Calendar files which are no longer needed may be deleted to increase available disk space. PERTMASTER will ask you to

Enter Calendar Name

To find out what files are on the disk before you delete a calendar file, type *DIR* and press ◀RETURN▶. This will give you a complete DIRectory of the calendar files on the disk.

Enter the name of the calendar file to be deleted, and press ◀RETURN▶. If you do not want to delete a file, press ◀ESCAPE▶.

4. Copy a Calendar File from one Disk to Another

This option allows you to copy calendar files within PERTMASTER. You will be asked

The Drive to be Copied From?

at which point you should enter the appropriate letter (or press ◀RETURN▶ for drive A). Then PERTMASTER will ask

The Drive to be Copied To?

Enter the appropriate letter (or press ◀RETURN▶ for drive B). You will then be asked to

Type the Name of the Calendar File

To find out what files are on either disk before you copy a calendar file, type *DIR* and press ◀RETURN▶.

Then type the name of the file to be copied, and press ◀RETURN▶. (Do not type the extension *.CAL* which follows the file name.) Press ◀ESCAPE▶ if you do not want to copy a file.

5. Finish Working with Calendars

Returns you to the Main Menu.

CREATE A NEW CALENDAR FILE

[Option 1 on Calendar Menu]

1. Calendar Name

When you select option 1 on the Calendar Menu, PERTMASTER will ask you to

Enter Calendar Name

To find out what files are on the disk before you choose a new file name, type *DIR* and press **◀RETURN▶**. This will give you a complete DIRectory of the calendar files on the disk.

All calendar files used by PERTMASTER will have the file extension “.CAL”. For example, you might have a calendar DAILY.CAL. This allows PERTMASTER to recognize which files are calendar files rather than data files of another type. You do not need to type this extension as PERTMASTER will always add it.

A calendar file name can be up to eight characters long. Only letters and numbers can be used, however, and the first character must be a letter. After typing the calendar name, press **◀RETURN▶**. If you do not wish to choose a file name, and want to return to the main Calendar Menu, press **◀ESCAPE▶**.

2. Calendar Range

After the calendar name has been typed, PERTMASTER will request you to

ENTER CALENDAR RANGE :**First Month (MMM/YY)****Last Month (MMM/YY)**

MMM/YY indicates the format in which the month is to be entered (for example, *JUL/83*). The total calendar may not be more than 120 months long and may not extend beyond the year 2049. Press **◀RETURN▶** after entering each month and year.

3. Normal Working Week

When the first and last months have been entered, PERTMASTER will display the following screen.

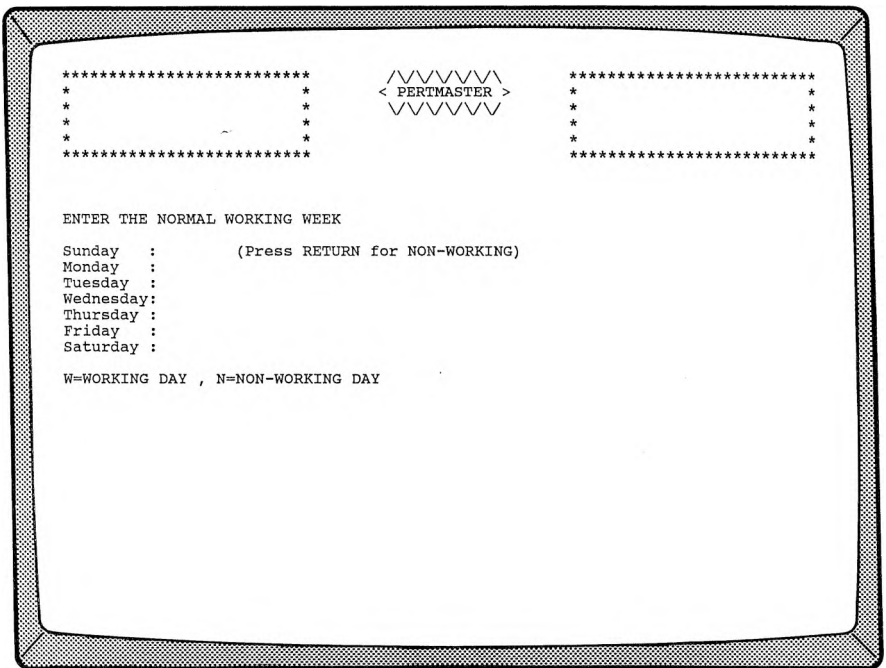

Each day of the week can be set to **WORKING** or **NON-WORKING** status by typing *W* or *N*. Saturdays and Sundays can be set to **NON-WORKING** by pressing **<RETURN>**. The remainder of the week can be set to **WORKING** by simply pressing **<RETURN>**.

The preceding routine makes PERTMASTER work in one-day time units. However, if you set only one day per week to **WORKING** status, PERTMASTER will calculate all its results by the week.

You may also have PERTMASTER calculate on a monthly basis. To do this, set all seven days of the week to **NON-WORKING**. Then, using option **3** of the Calendar Change/Display Menu (see Section 5.1.2.1), set one day per month to a **WORKING** day. Similarly, you can work in yearly quarters, or even in years, by setting only one day in the entire period to a "WORKING" day.

If you want to work in time units of your own choice, you may do so. The following method is particularly applicable to time units of less than one day, such as shifts, hours, or any division of your choosing.

Make a complete calendar, which is only one month long, with no working days whatsoever. Because all of the activities in your plan will then extend beyond the “end” of your calendar, they will be displayed as time-unit numbers in parentheses. Remember that there is no way to take into account non-working days or non-working periods when using this method.

When you are working in sub-time units of less than one day, a situation can arise in which a short activity may appear to take longer than it should. Assume, for example, that you are working eight hours a day, and have an activity which takes four hours. If PERTMASTER calculated that this activity should start on hour 7 of a given day, it would finish after hour 2 of the following day. Therefore, the report would use these dates correctly for the start and finish dates, but would specify a duration of two days.

4. Calendar Change/Display Menu

[See Section 5.1.2.1]

After the normal working week has been entered, the new calendar routine is merged into the change/display routine, starting with the Calendar Change/Display Menu.

**CHANGE OR DISPLAY AN EXISTING
CALENDAR FILE**

[Option 2 on Calendar Menu]

In response to this option, PERTMASTER will ask you to

Enter Calendar Name

To find out what files are on the disk before you enter the file name, type *DIR* and press ◀RETURN▶. This will give you a complete DIRECTORY of the calendar files on the disk.

After typing the name of the existing calendar which is to be changed or displayed, press ◀RETURN▶. The Calendar Change/Display will then appear; refer to Section 5.1.2.1.

CALENDAR CHANGE/DISPLAY MENU

Following the creation of a new calendar file, or designation of a calendar file to be changed or displayed, PERTMASTER produces the following menu.

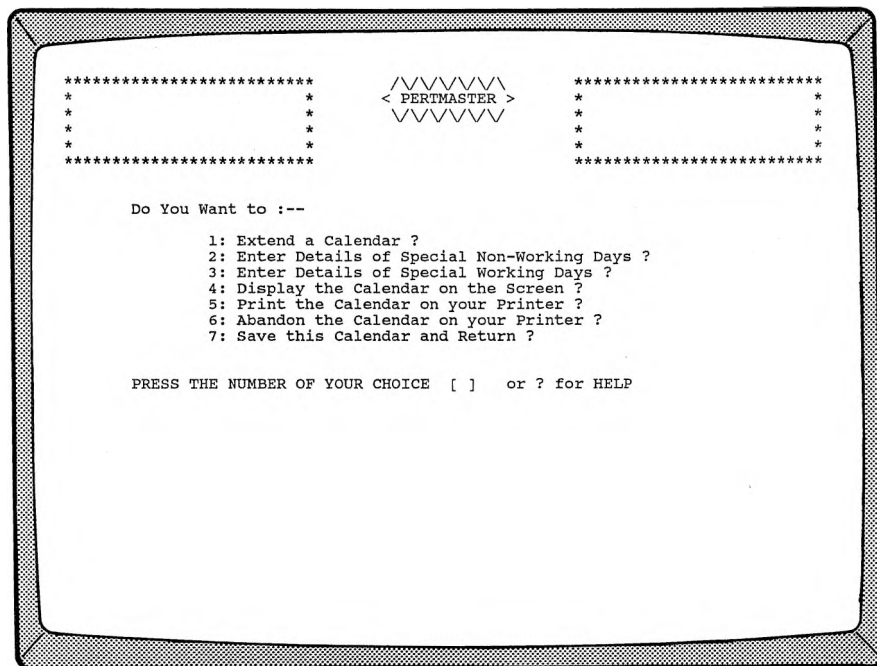

1. Extend a Calendar

You will be asked to

Enter New Last Month

Press **◀ESCAPE▶** to skip this option, or enter a new month in “MMM/YY” format (e.g. *JUL/83*), followed by a **◀RETURN▶**

PERTMASTER then requires the normal working week to be entered. Refer to Section 5.1.1.

2. Enter Details of Special Non-Working Days

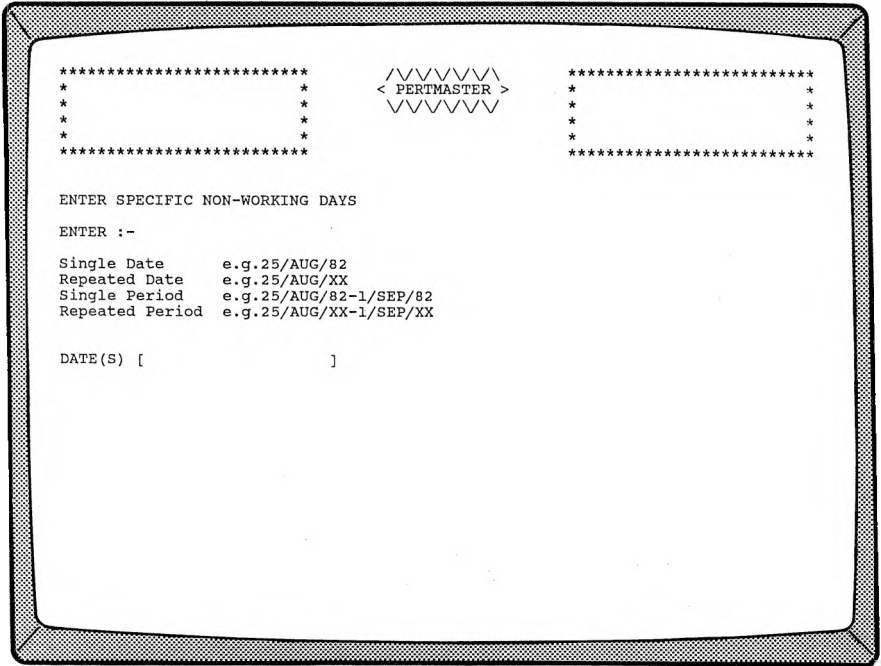

This option allows you to set holiday and vacation dates to prevent PERTMASTER from allocating work on these dates. Such dates or periods may be entered in four ways:

Single Date (e.g. *4/JUL/84*) in which case the date entered will be set to **NON-WORKING** regardless of its previous status.

Repeated Date (e.g. *4/JUL/XX*) in which case the date is set to **NON-WORKING** for every year in the calendar.

Single Period (e.g. *25/DEC/84-27/DEC/84*) in which case 25 through 27 December 1984 will be set to **NON-WORKING** days.

Repeated Period (e.g. *25/DEC/XX-27/DEC/XX*) in which case 25 through 27 December will be set to **NON-WORKING** days for every year in the calendar.

Press **◀RETURN▶** after typing the date(s).

PERTMASTER will not allow you to enter a period that spans a new year. For example, the entry 25/DEC/83-4/JAN/84 will be rejected. Enter this period as two separate periods, one for December and one for January.

As the second year in the entry will be the same as the first year, it may be omitted. If the second month in the entry is the same as the first month, it may be also be omitted. Therefore

25/DEC/84-27/DEC/84
25/DEC/84-27/DEC
25/DEC/84-27

are equivalent entries.

Press ◀**ESCAPE**▶ when all special **NON-WORKING** days have been entered.

3. Enter Details of Special Working Days

Special working days are entered in exactly the same way as described in paragraph 2 above, except that the dates you enter will be changed to **WORKING** status, regardless of their previous status.

The purpose of this routine is to allow you to set up working periods, such as selected weekends, that are outside your normal working days.

4. Display the Calendar on the Screen

You will be asked to

Enter Month and Year (MMM/YY)

where **MMM/YY** indicates the format (e.g. *JAN/83*). Press
◀**RETURN**▶ after entering the month and year.

PERTMASTER will display any monthly calendar on the screen. If the month is within the range of your calendar file, the working day numbers will also be printed on the calendar. Non-working days are designated - - -. Days which are outside the range of the calendar file are designated + + +.

Pressing ▶**RETURN**▶ will cause the succeeding month to be displayed. Pressing ▶**ESCAPE**▶ will allow you to enter a new month to be displayed. Pressing ▶**ESCAPE**▶ again, instead of entering a new month, will return you to the Calendar Change/Display Menu.

5. Print the Calendar on your Printer

This facility allows you to print the whole or any part of a calendar. Either two, three, or four months will be printed side by side on the paper, depending on the printer.

PERTMASTER will ask you to

Enter Period (MMM/YY-MMM/YY)

where **MMM/YY-MMM/YY** indicates the format (e.g. *JAN/83-JUN/83*). Press **◀RETURN▶** after typing the calendar period. If you simply press **◀RETURN▶**, the entire calendar file will be printed.

If the month is within the range of your calendar file, the working day numbers will also be printed on the calendar. Non-working days are designated ---. Days which are outside the range of the calendar file are designated +++.

6. Abandon this Calendar and Start Again

This option allows you to abandon the changes which you have made during the current session. It does not delete the calendar file which existed prior to the changes.

7. Save this Calendar and Return

This option saves to disk the calendar that you have been working on. The previous version of the calendar file will be eliminated (overwritten).

**WORK WITH ABBREVIATIONS
DICTIONARIES**

[Option 2 on Housekeeping Menu]

PERTMASTER abbreviations consist of two letters only. The maximum length of the expanded description is 38 characters.

PERTMASTER utilizes two types of abbreviations. The first is used to shorten common words and phrases, which reduces the time needed to enter data and also saves computer memory. An example of such a description, and its definition, is:

PC Prepare and cast concrete.

This type of abbreviation is entered into the descriptions of activities. At that time, it is preceded by an exclamation point to tell the computer that the next two letters are to be treated as an abbreviation. Thus the above example would be entered as **PC** when an abbreviations file is set up or changed, but would be entered as **!PC** when describing an activity.

The second type of abbreviation is used for resource categories. An example of a resource abbreviation, and its definition, is:

LA Laborers.

A resource abbreviation is followed by a number which denotes quantity (e.g. LA2) when used in plans. However, only the two letters are used in the abbreviations file.

There are two exceptions to the rule that the abbreviation must consist of letters. In the first position, the symbols “#” or “\$” may be substituted. These symbols are reserved for setting up special resource categories, and take the following forms:

\$X Cost in dollars
#Y Payment to consultant

The “\$” symbol is used to denote an expendable resource, such as money and materials, which will normally be exhausted at the end of the project. The “#” symbol identifies point resources, which are not spread across the entire project, but which are used up on the last day of an activity. Payment to a contractor on completion of an activity could be considered a point resource.

When option 2 of the Housekeeping Menu is selected, the following menu is displayed.

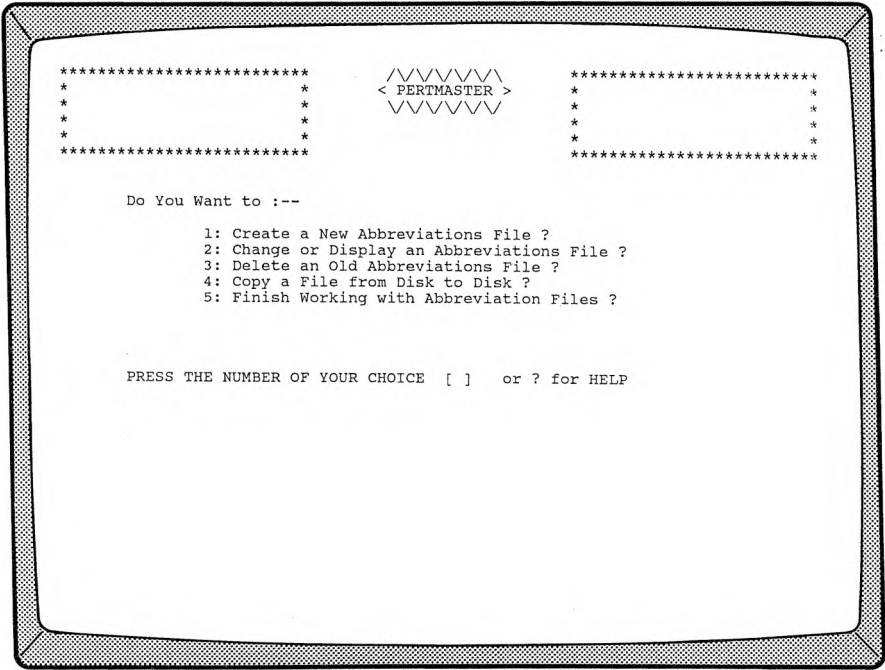

1. Create a New Abbreviations File [See Section 5.2.1]

This option is used when you wish to create a completely new abbreviations file.

2. Change or Display an Abbreviations File [See Section 5.2.2]

Option 2 allows you to revise or add to the abbreviations list.

3. Delete an Old Abbreviations File

Abbreviations files which are no longer needed may be deleted to increase available disk space. PERTMASTER will ask you to

Type the Name of the Abbreviations File

To find out what files are on the disk before you delete an abbreviations file, type *DIR* and press **<RETURN>**. This will give you a complete *DIR*ectory of the abbreviations files on the disk.

Enter the name of the abbreviations file to be deleted, then press **<RETURN>**. If you do not want to delete a file, press **<ESCAPE>**.

4. Copy a File From Disk to Disk

This option allows you to copy abbreviations files within PERTMASTER. You will be asked

The Drive to be Copied From?

at which point you should enter the appropriate letter (or press ◀RETURN▶ for drive A). Then PERTMASTER will ask

The Drive to be Copied To?

Enter the appropriate letter (or press ◀RETURN▶ for drive B). You will then be asked to

Type the Name of the Abbreviations File

To find out what files are on either disk before you copy an abbreviations file, type *DIR* and press ◀RETURN▶. Then type the name of the file to be copied, and press ◀RETURN▶. Press ◀ESCAPE▶ if you do not want to copy a file.

5. Finish Working with Abbreviations Files

Returns you to the Main Menu.

CREATE A NEW ABBREVIATIONS FILE [Option 1 on Abbreviations Menu]

1. Abbreviations File Name

When option 1 on the Abbreviations Menu is selected, PERTMASTER will ask you to

Enter the Name for this New Abbreviations File

To find out what files are on the disk before you choose a new file name, type *DIR* and press ◀RETURN▶. This will give you a complete DIRECTORY of the abbreviations files on the disk.

All abbreviations files used by PERTMASTER will have the file extension “.COD”. For example, you might have an abbreviations file WORK.COD. This allows PERTMASTER to recognize which files are abbreviations files rather than data files of another type. You do not need to type this extension as PERTMASTER will always add it.

An abbreviations file name can be up to eight characters long. Only letters and numbers can be used, however, and the first character must be a letter. After typing the file name, press ◀RETURN▶. If you do not wish to choose a file name, and want to return to the Abbreviations Menu, press ◀ESCAPE▶.

2. Abbreviations and Descriptions

After the file name has been typed, you will be asked to

Type the Next Abbreviation

which will be the first abbreviation in the new file. Abbreviations must consist of two letters, or must start with a \$ or a #, followed by a letter. PERTMASTER will convert lower-case letters to upper case, and will reject invalid abbreviations.

When the abbreviation has been entered, followed by a ◀RETURN▶, you will be asked to

Type the Full Description

which may be up to 38 characters long. Press ◀RETURN▶ after typing the description.

NOTE: An abbreviations file can contain a maximum of 100 abbreviations.

After all of the abbreviations and their descriptions have been entered, press ◀**RETURN**▶ when you are asked for the next abbreviation. This terminates the input to the new abbreviations file. The Abbreviations Change/Display Menu then is displayed (see Section 5.2.2.1).

**CHANGE OR DISPLAY AN
ABBREVIATIONS FILE**

[Option 2 on Abbreviations Menu]

In response to this option, PERTMASTER will ask you to

Type the Name of the Abbreviation File

To find out what files are on the disk before you enter the file name, type **DIR** and press **◀RETURN▶**. This will give you a complete **DIR**ectory of the abbreviations files on the disk.

After typing the name of the abbreviations file which is to be changed or displayed, press **◀RETURN▶**. The Abbreviations Change/Display Menu will appear. Refer to Section 5.2.2.1.

ABBREVIATIONS CHANGE/DISPLAY MENU

Following the creation of a new abbreviations file, or designation of an abbreviations file to be changed or displayed, PERTMASTER produces the following menu.

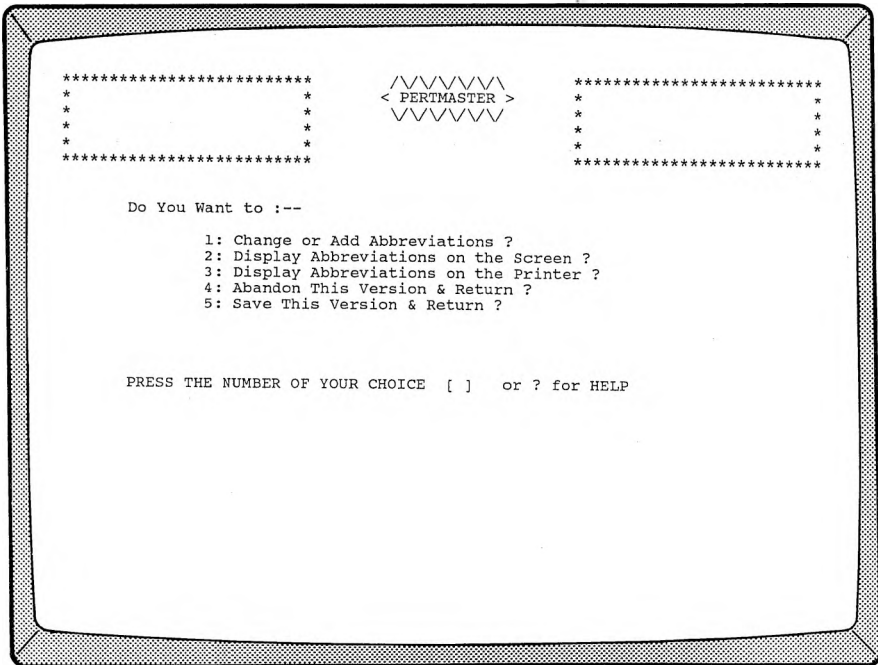

1. Change or Add Abbreviations

You will be asked to

Type the Next Abbreviation

If you wish to add a new abbreviation, enter a two-letter abbreviation or one which starts with a \$ or a #, followed by a letter. (PERTMASTER will convert lower-case letters to upper case, and will reject invalid abbreviations.) If you wish to change or delete an

existing abbreviation, type the abbreviation. An abbreviations file can hold up to 100 abbreviations.

PERTMASTER will then ask you to

Type the Full Description

For a new abbreviation, type a description up to 38 characters long. To change an old description, simply type over the description which is displayed on the screen. Use the space bar to overwrite characters from the old description which may remain.

If you do not want to change the description, simply press ◀RETURN▶. If you want to delete the description, type a - (dash or hyphen), and press ◀RETURN▶.

To exit the change/add routine, press ◀RETURN▶ when you are asked for the next abbreviation.

2. Display Abbreviations on the Screen

When option 2 is selected, the first ten abbreviations and their definitions will be displayed on the screen. Press ◀RETURN▶ to continue the listing. When all of the abbreviations have been displayed, press either ◀RETURN▶ to return to the Abbreviations Change/Display Menu, or ◀ESCAPE▶ to redisplay the abbreviations file.

3. Display Abbreviations on the Printer

This option will produce a printed report containing each abbreviation with its full description.

4. Abandon This Version & Return

This option allows you to abandon the changes which you have made during the current session. It does not delete the abbreviations file which existed prior to the changes.

5. Save This Version & Return

This option saves to disk the abbreviations file that you have been working on. The previous version of the file will be eliminated (overwritten).

CHANGE PRINTER DETAILS

[Option 3 on Housekeeping Menu]

Selecting option **3** on the Housekeeping Menu results in a display similar to the following.

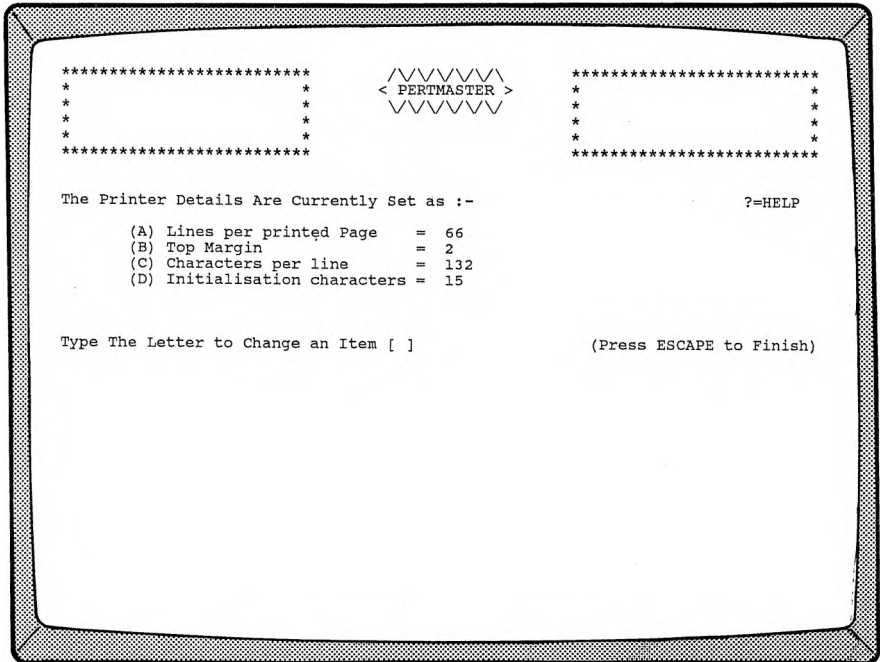

The appropriate letter is entered to change an item.

(A) Lines per printed page

This is the total number of lines that your printer can print on the paper sheet being used. For example, if you are using paper 11 inches high and your printer prints 6 lines per inch, the lines per printed page is 66. Enter the proper number and press **◀RETURN▶**.

(B) Top margin

This is the number of lines that you want your printer to leave blank at the top of the page. Type the desired number and press **◀RETURN▶**.

(C) Characters per line

Set this parameter to the number of characters that you wish to be printed on each line. The minimum number is 132, and maximum is 252. In general, 132 characters per line is ideal for most purposes, but for barcharts you should set a figure that is as high as your printer will allow. The figure can be changed for specific reports.

Type the appropriate number and press **◀RETURN▶**.

(D) Initialization characters

The initialization characters are used to control any special features that your printer may have, and will be sent to your printer at the start of each printed report. These characters must be the decimal numbers which correspond to the ASCII characters required to initialize the printer feature.

For example, when an 80-column dot-matrix printer is used, it is necessary to use a compressed character set (16.5 or more characters per inch) in order to print 132 characters on a line, as required by PERTMASTER. A typical printer might utilize an initialization string of ESC[6w, which must be converted to the decimal equivalents of each character, separated from one another with a / (slash). The ASCII-to-decimal equivalence is:

| <i>ASCII</i> | <i>Decimal</i> |
|--------------|----------------|
| ESC | 27 |
| [| 91 |
| 6 | 54 |
| w | 119 |

Therefore, you would enter the expression

27/91/54/119

as initialization characters, then press **◀RETURN▶**.

The initialization characters can be found in your printer manual. Usually the manual will also include an ASCII conversion table to allow you to enter the equivalent decimal numbers. If not, ask your technical advisor, or the dealer from whom the printer was purchased, to help you.

You can also use this feature to change from dot-matrix to double-strike or “correspondence” quality by choosing the appropriate initialization characters.

CHANGE OTHER SYSTEM DETAILS [Option 4 on Housekeeping Menu]

Selecting option 4 on the Housekeeping Menu allows you to change certain interface details between PERTMASTER and your computer system. A menu, similar to the following, will appear.

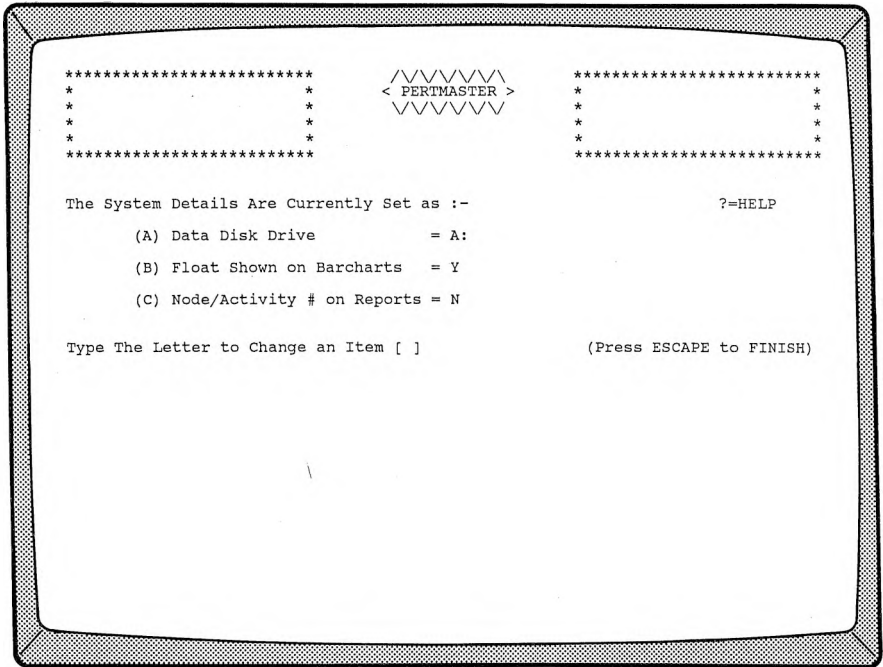

The appropriate letter is entered to change an item.

(A) Data Drive Number

You must specify the disk drive which will contain your plans, calendars, and abbreviation files. The disk drive "number" may be set to A, B, C, D, E, or F.

On a normal two-disk computer system, the PERTMASTER program disk will be in drive A. Maximum utilization of disk space will be

achieved by using a separate Data Disk in drive B. Therefore, the data drive number should be set to *B*. Different settings may be required for hard-disk systems.

(B) Float Shown on Barcharts

You have a choice whether or not float, or slack time, will be shown on printed barcharts. (It is always shown on screen barcharts.) Set item **(B)** to *Y* (Yes) or *N* (No).

Float is usually printed on management reports. It is normally not required on reports that are used by the work force.

(C) Node/Activity # on Reports

Setting this item to to *Y* (Yes) or *N* (No) dictates whether the node or activity numbers are printed on the reports.

Printing node or activity numbers takes up space on reports and reduces the length of the available description field to 32 characters. Because using node or activity numbers also takes up extra memory space, it may cause problems with printing large plans. If this happens, try printing large plans without the numbers.

After making changes, press ◀**ESCAPE**▶ to return to the Main Menu.

DELETE OLD PLANS FROM A DISK [Option 5 on Housekeeping Menu]

This option is used to clear any unwanted plans from a disk. A display, similar to the one below, will be shown.

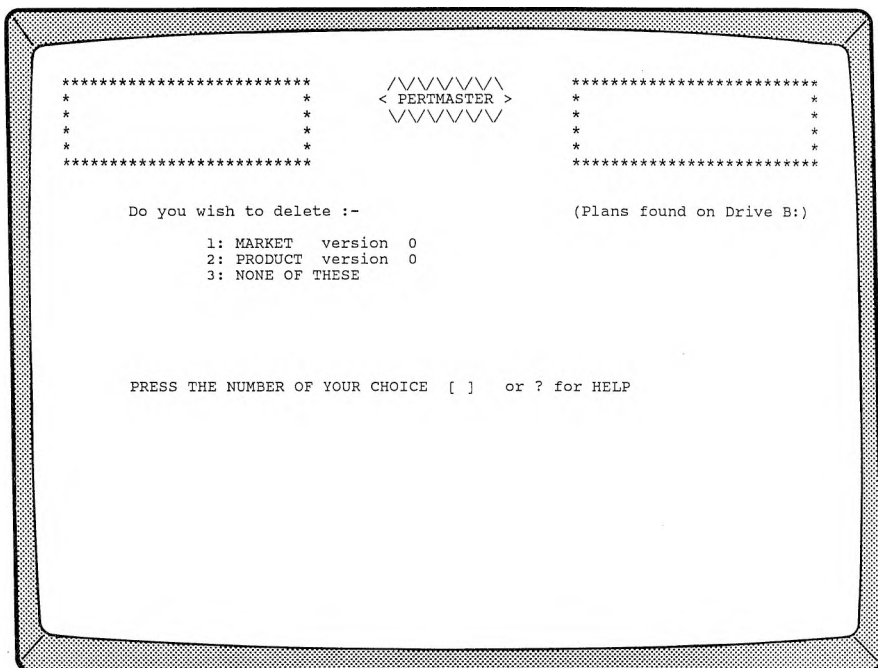

All of the plans on your data disk will be listed. If there are more plans on the disk than PERTMASTER can display at one time on the screen, the last option will be **OTHER PLANS ON THIS DISK**. Select this option if you wish to delete a plan which is not on the initial list.

When you choose a plan to be deleted, you will be asked to confirm your choice. Once the plan has been deleted, you will be asked if you wish to go through this routine again. Type *Y* (Yes) if you do, or *N* (No) if you do not. When you type *N* you will be returned to the Housekeeping Menu.

It is also possible to delete plans from your disk, via the computer operating system, without using PERTMASTER's deletion facility. This is a bad practice, and should be avoided, as PERTMASTER maintains a list of plans in a file called INDEX. Deleting plans using PERTMASTER's facility keeps the INDEX file up-to-date; deleting plans using the operating system does not. If INDEX is not updated, at a future time you may attempt to load a plan which has been deleted, since the plan name will remain in the INDEX file and will be displayed on the list of plans on your data disk.

**COPY PLANS FROM ONE DISK TO
ANOTHER DISK**

[Option 6 on Housekeeping Menu]

This option is designed to copy a plan from one disk to another disk; all data will be transferred. You should use this feature when you want to create back-up copies of your plans.

PERTMASTER keeps an list of the plans on each disk in a file called INDEX. If you copy a plan from one disk to another by using the operating system copy command, the PERTMASTER index will not be kept up to date.

When copying a plan from one disk to another, you will be asked

The Drive to be Copied From?

at which point you should enter the appropriate letter (or press ◀RETURN▶ for drive A). Then PERTMASTER will ask

The Drive to be Copied To?

Enter the appropriate letter (or press ◀RETURN▶ for drive B).

A list of the plans on the disk will then be listed in a format similar to the following.

If there are more plans on the disk than PERTMASTER can display on the screen, the last option will be **OTHER PLANS ON THIS DISK**. Select this option if you wish to merge a plan which is not on the initial listing.

Type the number of the plan which is to be merged. You will immediately be asked to

Please enter the offset value

The offset value is a number which will be added to (if you enter a positive number) or subtracted from (if you enter a negative number) the node or activity numbers in the plan as it is merged into the new plan. This prevents duplication of node or activity numbers in plans which are being merged. If you do not want to offset the node or activity numbers, press **◀RETURN▶**.

NOTE: You can renumber a plan, using this facility, by merging it into a new plan to which you have given the same name. This will automatically create version 0 of the plan. If the original plan was also version 0, PERTMASTER will tell you that you are going to lose the original.

Next, PERTMASTER will request you to

Please enter the code to be entered in descriptions

This code is any word or group of characters, having a maximum length of 20 characters, which you can add to the descriptions in the plan being merged. It is used to differentiate between the descriptions in the plans which will be merged. (If you do not want to insert a code, simply press **◀RETURN▶**.) You can also select the position of the code in the description when PERTMASTER asks you to

Please enter the position for the code

If you want the code inserted at the start of the descriptions, press **◀RETURN▶**. Otherwise, enter a number between 1 and 39 to designate the position at which your code is to start, and press **◀RETURN▶**. Since descriptions are limited to 40 characters, you must not start your code at a position which would cause it to exceed that limitation.

PERTMASTER will now redisplay the list of plans so that you can select the next plan to be merged. When you have finished merging, type the number corresponding to **NONE OF THESE**. The new plan will be saved and you will be returned to the Main Menu.

RULES OF MERGING

1. You cannot merge Precedence and Arrow Plans together. PERTMASTER will display an error message if the second or any succeeding plan is a different type.
2. If two activities have the same node or activity numbers, the last description and duration will be used.
3. If two links of the same type connect the same two activities in a Precedence Plan, the last duration will be used.
4. All activities that would have a preceding node number of one or less (because of a subtractive offset) will be designated as starts.
5. PERTMASTER will include only the first 40 characters of your descriptions.

NETWORK FORMATS

Arrow (Activity-on-Arrow)

Precedence (Activity-on-Node), complete with three link types and lead and lag durations.

Both formats allow multiple starts and finishes for appropriate time constraints.

MAXIMUM NETWORK SIZE

CP/M Computers and HP-110 Portable Computer 500 activities

MS-DOS and PC DOS Computers with

 128k Memory 1000 activities

 256k Memory 1500 activities

 256k Memory (special version) 2500 activities

ACTIVITY HANDLING

Description Length 40 characters max.

Activities may be coded with management or other codes.

RESOURCE HANDLING

Number of Resource Types per Network 29 max.

Number of Resource Types per Activity 10 max.

Resource types and quantities fully definable by user.

TIME

Range: Any time units from seconds to years can be accommodated.
Time units, such as shifts, can be user-defined.

Calendars: User-defined, up to 10 years long.
Separate calendar may be used for each project, or changed within a project.

ABBREVIATIONS

User can set up abbreviation tables to facilitate coding and resource handling.

REPORTS

Printed Reports

- Network Listing
- Standard Date Listing
- Complete Project Barchart
- Period Barchart
- Resources Listing
- Resource Histogram
- Cash-Flow Curve
- Milestone Report

Screen Reports

- Barchart
- Date Listing
- Resource Histogram

Disk Reports

- Time Analysis Report
- Resources Report

All reports have a wide variety of options, including activity selection and sorting.

DATA TRANSFER

Files easily transferred to and from other software packages.

MISCELLANEOUS FEATURES

Merging of sub-projects for consolidation.

Library networking from skeleton plans.

Batch commands for repetitive operation.

Full technical support with program updates available.

UNNUMBERED ERROR MESSAGES

An error message which results from an invalid plan entry, or from certain limitations of the program, will appear on the screen as an unnumbered statement. These messages are listed below with an explanation of the message and the remedial action which should be taken.

ACTIVITY EXISTS – NEW LINKS ONLY

This is simply a warning message. If you wish to add new links to an existing activity, you type the activity number. The existing activity will be displayed, with this warning message, so that you know the status of your plan. The cursor will then be displayed in the **TO** (link) column, so that you can add your new link(s).

ACTIVITY MUST BE ENTERED

This message is given when you are editing a Precedence plan, and have entered neither the activity number nor a link number. One of the two must be entered. Press **◀ESCAPE▶** to take you back to the start of the line, and try again.

ACTIVITY SPACE IS FULL

This message will occur when you have entered the maximum number of activities in an Arrow plan. If you still have activities to enter, then you will have to consider combining activities to stay within the limits allowed, or splitting your plan into separate plan sections.

ACTIVITY xxxx IS A DANGLE

The numbered activity has no preceding activity or no succeeding activity. This error message is given while you are analyzing a Precedence plan.

CANNOT DELETE START/FINISH

When you create a Precedence plan, the start node and the finish node are inserted automatically for you. Multiple starts and finishes are created by setting additional links to activities from these nodes. As a protection, PERTMASTER will not allow you to delete the start and finish nodes themselves. If you wish to delete a start or a finish, simply delete the links to/from these nodes.

CODE NOT ALLOWED

This message will appear when you are trying to produce a screen histogram, and have entered a resource code starting with “#” or “\$”. These resource codes generate cash-flow curves, rather than histograms, which cannot be displayed on screen.

DD/MMM/YY IS AN INVALID DATE

This error will occur while you are working with calendars. The system cannot understand the date that you have just typed. Ensure that you have typed the date using the PERTMASTER date format which is shown on the screen.

DD/MMM/YY OUT OF RANGE

The date that you have just entered is not within the range of the calendar with which you are working. This error will occur while you are setting working/non-working days in a calendar.

DUPLICATE ACTIVITY

In Arrow plans, no activity may have the same preceding and succeeding node numbers. If you wish to show parallel activities, then you must use a dummy activity to avoid creating a duplicate activity.

DURATION TOO LONG

The maximum duration that can be entered for an activity is 4999 time units.

END OF PLAN

This error message arises when you have typed a node/activity number that is outside the range allowed for your system.

ERROR: CALENDAR LIMIT EXCEEDED

This error will occur when you have attempted to extend a calendar beyond the limit of 120 months per calendar. If a significant part of your calendar has already passed, try designing a new calendar with a later start date.

ERROR: INCORRECT EXTENSION PERIOD

This error will occur when you have attempted to extend a calendar into a period that does not follow the original calendar period.

INVALID ACTIVITY

This error message is given while you are entering a Precedence plan, and have entered an activity number that is non-numeric or out of range for your computer.

INVALID ENTRY

This message is given when you enter an invalid command while you are editing a Precedence plan. Use the help function to see the valid commands.

INVALID NODE NUMBER

This message shows that you have entered a non-numeric node number or a node number that is outside the range allowed for your computer.

INVALID VOLUME NAME OR VOLUME NOT AVAILABLE

This message will appear when you enter a letter for a disk drive that is not available on your system. PERTMASTER checks at this time that such a drive is available by creating and deleting a temporary file.

LETTERS ONLY PERMITTED IN ABBREVIATIONS

An abbreviation consists of two characters. The first may be any letter, or #, or \$; the second may only be a letter.

LOOP DETECTED IN PLAN. Suspect activities are: x1,x2:

A loop of activities has been detected. These would cause you to repeat activities indefinitely, and you would never reach the end of your project. PERTMASTER gives you a list of nodes. These will include the nodes that cause the dangle, but may include other nodes as well. PERTMASTER can only catch one dangle or loop at a time. It is therefore possible, particularly with a large network, to correct one loop or dangle only to reveal another. This error message is given while you are analyzing a precedence plan.

LOOP DETECTED IN PLAN. Suspect nodes are: x1x2:

A loop of nodes has been detected. These would cause you to repeat activities indefinitely, and you would never reach the end of your project. PERTMASTER gives you a list of nodes. These will include the nodes that cause the dangle, but may include other nodes as well. PERTMASTER can only catch one dangle or loop at a time. It is therefore possible, particularly with a large network, to correct one loop or dangle only to reveal another. This error message is given while you are analyzing an Arrow plan.

MUST BE ENTERED

This message is given when you are adding or editing a link in a Precedence plan. You must enter a link type (either 1,2,3,S, or F).

NO SUCH LINE NUMBER

The line numbers shown in the left column of the screen while you are inserting new activities or editing a plan range from 1 to 19. If you enter a number outside this range, or higher than the last activity shown, then PERTMASTER will give this error message.

NO SUCH RESOURCE

This message will appear when you have entered an invalid resource code while trying to display a screen histogram.

NODE/ACTIVITY NUMBERS TOO LARGE FOR THIS SYSTEM

You will see this message if you have copied a PERTMASTER plan from one large system to a smaller PERTMASTER system where lower activity number limits are in force. You can correct this error in two ways. Either use a word processor to change node/activity numbers manually to fall within the new limits, or use the larger PERTMASTER system to achieve the same thing.

NODE MUST BE ENTERED

This message will occur when you have entered neither the **FROM** node nor the **TO** node in an Arrow plan. One of the two types of node must be entered.

NODE xxxx IS A DANGLE

The numbered node has no preceding node or succeeding node. This error message is given while you are analyzing an Arrow plan.

OUT OF RANGE ACTIVITY

This error message is given while you are merging plans together, and an activity is found which has node/activity numbers outside the range allowed for your computer. Note that the node/activity numbers will have had the offset that you entered added to them, and it may be that this offset is forcing an otherwise valid activity to be out of range.

OUT OF RANGE LINK

This error message is given while you are merging plans together, and a link is found which has node/activity numbers outside the range allowed for your computer. Note that the node/activity numbers will have had the offset that you entered added to them, and it may be that this offset is forcing an otherwise valid link to be out of range.

OUT OF RANGE MILESTONE

This error message is given while you are merging plans together, and a milestone is found which has node/activity numbers outside the range allowed for your computer. Note that the node/activity numbers will have had the offset that you entered added to them, and it may be that this offset is forcing an otherwise valid milestone to be out of range.

PLEASE USE THE INSTALL PROGRAM BEFORE RUNNING THE SYSTEM

This means that PERTMASTER cannot find the terminal set-up files that are appropriate to your computer system. Included with your copy of PERTMASTER will be a program called INSTALL.EXE (or INSTALL.COM for CP/M-80 computers). Run this program to generate the terminal set-up files that are required.

Note that on the large majority of computer systems, PERTMASTER is supplied pre-installed. The INSTALL program is not supplied in these cases, and is never required.

START OR FINISH MISSING:

Every plan must have at least one start and one finish. You may have multiple starts and finishes. This error message is given while you are analyzing an Arrow plan.

THE LINK SPACE IS FULL

The limit of activities that is applicable for your copy of PERTMASTER is also applicable to the number of links. For example, if you are limited to 1500 activities, then you are also limited to 1500 links. In a Precedence plan, it is normal that you will reach the link limit before you reach the activity limit. The solutions are the same as reaching the activity limit. You must either try combining activities, or split your plan into appropriate sections.

THE MAXIMUM NUMBER OF ACTIVITIES HAS BEEN REACHED

This error message will be given while you are trying to merge plans together, and have reached the limit of activities available for your computer.

THE MEMORY CAPACITY OF YOUR MACHINE IS TOO SMALL

This message is generated by PERTMASTER versions which have a 1500 or 2500 activity limit. These versions will only run on computers with 256k bytes of memory or greater. PERTMASTER checks at the start of each run to see if it has enough memory. You have two options if this error message is displayed. You can either add more memory to your computer, or exchange your version of PERTMASTER for a 1000-activity version which will run in 128k memory machines.

THERE ARE NO PLANS ON THIS DISK

This message will be given when you attempt to print plans from a disk, and PERTMASTER cannot find any plans. If you think that there are plans on the data disk, use the manual load command to retrieve them.

THIS PLAN IS THE WRONG TYPE

The merge facility of PERTMASTER allows you to merge plans of the same type. The plan type of the resulting plan is the same as that of the first plan that you merge. If you subsequently try to merge a plan of a different type, this error message will result.

TYPE 1,2,3,S,F OR ? ONLY

This message will appear when you have typed an invalid letter or number for a link type. You may only type one of the characters shown.

NUMBERED ERROR MESSAGES

When certain errors occur, the error number is given at the bottom of the screen. Some of these errors indicate a problem with your computer hardware, some with program operation, and still others (hopefully few!) indicate a fault with PERTMASTER.

To use the following list, read the error number and then take the remedial action described in the like-numbered paragraph which follows the list.

| <i>Error No.</i> | <i>Error Message</i> | <i>Remedial Action</i> |
|------------------|----------------------------|------------------------|
| 1 | NEXT Without FOR | 1 |
| 2 | Syntax Error | 1 |
| 3 | RETURN Without GOSUB | 1 |
| 4 | Out Of Data | 1 |
| 5 | Illegal Function Call | 1 |
| 6 | Numeric Overflow | 1 |
| 7 | Out of Memory | 2 |
| 8 | Undefined Line Number | 1 |
| 9 | Subscript Out Of Range | 1 |
| 10 | Duplicate Array Definition | 1 |
| 11 | Division By Zero | 1 |
| 12 | Illegal Direct Statement | 1 |

| <i>Error No.</i> | <i>Error Message</i> | <i>Remedial Action</i> |
|----------------------|-------------------------------|----------------------------|
| 13 | Variable Type Mismatch | 1 |
| 14 | Out Of String Space | 2 |
| 15 | String Too Long | 1 |
| 16 | String Formula Too Complex | 1 |
| 17 | Cannot Continue | 1 |
| 18 | Undefined User Function | 1 |
| 19 | Error Trap Without RESUME | 1 |
| 20 | RESUME Without Error Trap | 1 |
| 22 | Missing Operand | 1 |
| 23 | Line Buffer Overflow | 1 |
| 24 | Device Timeout | 3 |
| 25 | Device Fault | 3 |
| 26 | FOR Without NEXT | 1 |
| 27 | Printer Out Of Paper | 3 |
| 29 | WHILE Without WEND | 1 |
| 30 | WEND Without WHILE | 1 |
| 50 | FIELD Overflow | 1 |
| 51 | Internal Error | 1 |
| 52 | Bad File Number | 1 |
| 53 | File Not Found | 4 |
| 54 | Bad File Mode | 4 |
| 55 | File Already Open | 4 |
| 57 | Device I/O Error | 3 |
| 58 | File Already Exists | 4 |
| 61 | The Disk Is Full | 5 |
| 62 | Input Past End Of File | 4 |
| 63 | Bad Record Number | 4 |
| 64 | Bad File Name | 4 |
| 66 | Direct Statement In File | 1 |
| 67 | Too Many Files In Directory | 6 |
| 68 | Device Unavailable | 3 |
| 69 | Communication Buffer Overflow | 1 |
| 70 | The Disk Is Write Protected | 7 |
| 71 | The Disk Is Not Ready | 4 |
| 72 | Disk Media Error | 4 |
| 73 | Advanced BASIC Feature Used | 1 |
| 74 | Tried To RENAME Across Disks | 1 |
| 75 | Path Or File Access Error | 1 |
| 76 | Path Not Found | 1 |

REMEDIAL ACTION

1. These errors are most unlikely to occur; they indicate an error in the program. If such an error occurs, please call Westminster Software technical support for assistance. It will be most helpful to the technical support service if you can describe the error, and give the error number, and error line number (also on the screen at this time). Giving such details will help you receive a quicker and more accurate solution of your problem.
2. These errors indicate that all available memory has been used. You should shorten descriptions and/or use fewer activities, and try again.
3. These errors are generally caused by a printer that is incorrectly connected, not switched on, not loaded with paper, or otherwise not ready to print. Check your printer and try again.
4. These errors occur while PERTMASTER is searching for a file on a disk. First check that PERTMASTER is looking at the correct disk, that the disk-drive gate is closed, and that the file is present. The file name will always be given along with the error code. If all else fails, you can ascertain that the file really is present by leaving PERTMASTER, and then using the DIRECTORY function of your operating system.
5. If this error occurs, you will be able to back-track through a PERTMASTER menu, until you can either delete an unwanted previous version of a plan or change disks.
6. This error will only occur while using MS-DOS 2.0 (PC DOS 2.0) or later versions. This problem is only likely to arise when you are working with many files on a hard disk, because the operating system allows only a limited number of files to be in the root directory. PERTMASTER should always be operated from a sub-directory. We recommend that you create a separate sub-directory for PERTMASTER, such as "\pert", and keep all your data files there. Refer to your computer operating manual if you need help in making and changing directories.
7. Remove the write-protect tab from the disk, and try again. Note that both the PERTMASTER program disk and the data disk are written to; neither can be write-protected.

TYPE-AHEAD

Type-Ahead provides the expert user with a rapid, abbreviated mode of entering instructions. Whenever a major menu is displayed, a sequential list of menu selections may be entered. PERTMASTER will execute each selection in turn, each time it needs an input, until it runs out of instructions or is faced with an invalid instruction.

For example, suppose that you want to get a screen barchart from version 0 of a plan titled HOUSE. Starting with the Main Menu, the options which would be selected are:

| <i>Menu</i> | <i>Selection</i> |
|--------------------------|---|
| Main Menu | 2 (Get Reports From an Up-to-Date Plan) |
| Plans List | 1 (HOUSE version 0) |
| Report Menu | 6 (Screen Barchart) |
| Screen Barchart Menu | 1 (The Earliest Activities First) |
| Selective Reporting Menu | ◀RETURN▶ (All Activities Printed) |
| Report Menu | 8 (Start or Cancel the Run) |
| | ◀RETURN▶ (Start the Run) |

To enter these selections as a Type-Ahead command, type & (ampersand) instead of an option number when the Main Menu is displayed.

PERTMASTER will request you to:

Please Enter Your Type-Ahead Command

and will redisplay the &. Now enter the above selections in the order in which they are to be implemented; use a period between the individual entries, or two periods to denote ◀RETURN▶ within the command. Terminate the command with an actual ◀RETURN▶. The preceding list of inputs would therefore be entered as

2.1.6.1..8.. ◀RETURN▶

PERTMASTER will execute the commands in that sequence, and will ultimately display the screen barchart.

EXECUTIVE TYPE-AHEAD

Executive Type-Ahead uses the same command structure as Type-Ahead, but allows you to record the set of instructions for future use. This is

especially useful for generating the same report or group of reports frequently.

In this case, assume that you want a printed histogram for laborers, whose resource code is "LA", used in HOUSE version 0. Starting with the Main Menu, the options which would be selected this time are:

| <i>Menu</i> | <i>Selection</i> |
|--------------------------|---|
| Main Menu | 2 (Get Reports From an Up-to-Date Plan) |
| Plans List | 1 (HOUSE version 0) |
| Report Menu | 5 (Histogram for a Resource) |
| Histogram Menu | 1 (All Activities Start as Early As Possible) |
| Start Report From | ◀RETURN▶ (Day Now) |
| Abbreviation of Resource | LA |
| Report Menu | 8 (Start or Cancel the Run) |
| | ◀RETURN▶ (Start the Run) |
| More Reports | N (No) |

To enter these selections as an Executive Type-Ahead command, again type & instead of an option number when the Main Menu is displayed. PERTMASTER will again request you to:

Please Enter Your Type-Ahead Command

and will redisplay the &. Enter an initial instruction which takes the form "Rn.", where "R" means Record and "n" is any number less than 32,767. The number identifies the set of instructions which you are going to enter, and which will be recorded. For this example, use number 5.

Following **R5**, enter the above selections in the order in which they are to be implemented. As with Type-Ahead, use a period between the individual entries, or two periods to denote ▶RETURN▶ within the command. Terminate the command with an actual ▶RETURN▶. The preceding list of inputs would therefore be entered as

R5.2.1.5.1..LA.8..N ▶RETURN▶

PERTMASTER will execute the commands in that sequence, will ultimately print the histogram, and will then return to the Main Menu.

The next time that you want to get the same report, all you need do is type **E5** when the ampersand is displayed, and press ▶RETURN▶. "E" is the command to Execute the instruction-set number. Therefore, typing **E5** will cause PERTMASTER to execute the command sequence that you previously entered and recorded as instruction set 5.

You could conceivably record 32,767 instruction sets, numbered from 1 to 32,767. If you record an instruction set using a number that has been used before, the old instruction set will be replaced with the new one.

The maximum number of characters which may be incorporated in either a Type-Ahead or Executive Type-Ahead command is defined by the brackets which appear on the screen after the ampersand. You cannot exceed this limitation.

TRANSFERRING PERTMASTER FILES TO dBASE II AND OTHER DATABASES

Because PERTMASTER stores all its data in standard ASCII files with fixed fields, it is quite easy to transfer these files to dBASE II and similar database programs.

While we encourage you to transfer data from PERTMASTER to other programs in order to provide additional facilities beyond those provided by PERTMASTER, we recommend that you not transfer data the other way. PERTMASTER does a great deal of error checking on data that are input within the system. Bad data that are input by transfer may bypass all of PERTMASTER's checks and, as a result, generate false information on reports.

Each PERTMASTER file will require two separate database files — one for the file heading and one for the main body of the file. Each field in each of the two database files will contain a string in quotes or a numeric value. Each line of data in the PERTMASTER file will become a record in the database files which you create. Printouts of sample PERTMASTER data files for an Arrow Plan and a Precedence Plan appear at the end of this appendix.

The commands specified below for dBASE II also apply to dBASE III. Other database programs will have commands which correspond to those given; the method used to transfer data will be similar.

The file heading is the first line of the PERTMASTER file. Using dBASE II, create a database file to store this information, as follows:

| <i>NAME</i> | <i>TYPE</i> | <i>WIDTH</i> | <i>DEC.</i> | <i>Explanation</i> |
|-------------|-------------|--------------|-------------|----------------------------------|
| HEADER | C | 001 | 000 | Field 1: always "H" in any plan |
| PLANTYPE | C | 010 | 000 | Field 2: precedence or arrow |
| CTITLE | C | 030 | 000 | Field 3: center report title |
| LTITLE | C | 030 | 000 | Field 4: left report title |
| RTITLE | C | 030 | 000 | Field 5: right report title |
| CALENDAR | C | 008 | 000 | Field 6: calendar file name |
| CODEFILE | C | 008 | 000 | Field 7: abbreviations file name |
| TIMENOW | N | 004 | 000 | Field 8: time now |
| SUBTIME | N | 004 | 000 | Field 9: sub-time unit |

After you have created this database file, fill it with the plan heading by using the dBASE II command

APPEND FROM filename FOR HEADER = "H" DELIMITED

To transfer the body of the PERTMASTER file to dBASE II, slightly different database files are needed for Arrow and Precedence Plans. For an Arrow Plan, create the following database file:

| <i>NAME</i> | <i>TYPE</i> | <i>WIDTH</i> | <i>DEC.</i> | <i>Explanation</i> |
|-------------|-------------|--------------|-------------|----------------------------------|
| LINETYPE | C | 001 | 000 | Field 1: A=activity, M=milestone |
| FROMNODE | N | 004 | 000 | Field 2: preceding node number |
| TONODE | N | 004 | 000 | Field 3: succeeding node number |
| DURATION | N | 004 | 000 | Field 4: remaining duration |
| DESCRIPT | C | 040 | 000 | Field 5: activity description |
| RESOURCES | C | 040 | 000 | Field 6: activity resources |

Fill this database file by using the dBASE II command

***APPEND FROM filename FOR LINETYPE = "A" .OR.
LINETYPE = "M" DELIMITED***

Start activities will be identified by a preceding node number of zero; finish activities will show a succeeding node number of zero.

To transfer the body of a Precedence Plan to dBASE II, create the following database file:

| <i>NAME</i> | <i>TYPE</i> | <i>WIDTH</i> | <i>DEC.</i> | <i>Explanation</i> |
|-------------|-------------|--------------|-------------|---|
| LINETYPE | C | 001 | 000 | Field 1: A=activity, M=milestone, L=link |
| ACTIVITY | N | 004 | 000 | Field 2: activity number or link start number |
| LINK | N | 004 | 000 | Field 3: activity number or link finish number |
| DURATION | N | 004 | 000 | Field 4: remaining duration |
| DESCRIPT | C | 040 | 000 | Field 5: activity description or link type |
| RESOURCES | C | 040 | 000 | Field 6: activity resources |

Fill this database file by using the dBASE II command

***APPEND FROM filename FOR LINETYPE = "A" .OR.
LINETYPE = "M" .OR. LINETYPE = "L" DELIMITED***

Records of activities which are not starts or finishes will have the same activity number in fields 2 and 3. Start activities will be identified by a one in field 2. Finish activities will show 500, 1500, or 2500 in field 3; the number will depend on the computer that you are using.

TRANSFERRING PERTMASTER FILES TO LOTUS 1-2-3

PERTMASTER's Disk Reports must be used to transfer data to Lotus 1-2-3. Therefore, the first step is to generate Disk Reports of the plan which you wish to use, as explained in Reference Section 4.6.

The disk files which are produced as Disk Reports all have a numeric extension, such as TPRODUCT.0 and EMARKET.2. Since Lotus 1-2-3 will only accept data files having a ".PRN" extension, you must rename the files accordingly. For the examples just mentioned, TPRODUCT.0 would be renamed TPRODUCT.PRN, and EMARKET.2 would become EMARKET.PRN.

Call up Lotus 1-2-3 and put a blank 1-2-3 worksheet on the screen. Then type */FIN* (File Import Numbers) and enter the name of the data file that you wish to work with. Lotus 1-2-3 will load this file and display it on the screen.

The screen display will probably be somewhat disorganized. Rectify this by setting the column widths to an appropriate size for the data which are in each column. Also delete any columns which are not necessary for your purposes.

Note that the first line of the display will contain the plan heading information. Subsequent lines will contain detailed information about each activity in the plan. Reference Section 4.6 fully explains the data which are recorded in the disk files.

You are not restricted to loading one data file at a time from PERTMASTER. In fact, the most powerful use of this facility is to compare different PERTMASTER reports, such as a scheduled plan versus an actual plan.

Once you have the plan or plans on the screen, you can use the full range of Lotus 1-2-3 commands to work with the information.

TRANSFERRING PERTMASTER FILES TO SUPERCALC

PERTMASTER's Disk Reports must be used to transfer data to SuperCalc, SuperCalc 2, and SuperCalc 3. Therefore, the first step is to generate Disk Reports of the plan which you wish to use, as explained in Reference Section 4.6.

The disk files which are produced as Disk Reports all have a numeric extension, such as LPRODUCT.0 and TMARKET.2. Since SuperCalc will only accept data files having a ".CAL" extension, you must rename the files accordingly. For the examples just mentioned, LPRODUCT.0 would

be renamed LPRODUCT.CAL, and TMARKET.2 would become TMARKET.CAL.

Call up SuperCalc and load, in the usual way, the disk file that you have made. The screen display will probably be somewhat disorganized. Rectify this by setting the column widths to an appropriate size for the data which are in each column. Also delete any columns which are not necessary for your purposes.

Note that the first line of the display will contain the plan heading information. Subsequent lines will contain detailed information about each activity in the plan. Reference Section 4.6 fully explains the data which are recorded in the disk files.

You are not restricted to loading one data file at a time from PERTMASTER. In fact, the most powerful use of this facility is to compare different PERTMASTER reports, such as a scheduled plan versus an actual plan. The second and subsequent plans to be entered should be loaded with a SuperCalc command like

/Load, <FILENAME>,Part,All,X99

This form of load command will place the second plan at a specific location (e.g. X99) and will avoid erasing the first plan.

Once you have the plan or plans on the screen, you can use the full range of SuperCalc commands to work with the information.

PERTMASTER ARROW PLAN FILE

```

A → H# "ARROW", "MARKETING A NEW PRODUCT", "Westminster Software Inc.", "Palo Alto CA
M# 0,1,0, "START"
M# 1,1,0, "START PRODUCT PLANNING", ""
B → A# 1,2,3, "GM Develop IPR Design Concepts", "PE2 P01 EC4 SM4 $P460"
B → A# 1,3,4, "GM develop IPR Marketing Plan", "PE2 P01 EC4 SM4 $P460"
A# 1,4,5, "GM Create IPR Business Plan", "PE2 P01 EC4 SM4 $P460"
C → A# 2,4,3, "GM Develop Production Plan", "PE2 P01 EC2 SM2 $P460"
A# 3,4,3, "GM Negotiate License Agreement", "PE1 P01 EC1 SM1 $P260"
A# 4,5,2, "GM Approve IPR Plans and Design", "PE4 P01 EC2 SM2 $P860" ← E
M# 5,5,0, "FINISH INITIAL PLANNING", ""
A# 5,6,3, "GM Create and Approve IPR Budget", "PE1 P02 EC2 SM2 SD2 $P320"
A# 6,7,3, "GM Appoint IPR Manager", "PE2 P01 EC1 SM1 SD1 $P460"
M# 7,7,0, "READY TO INITIATE PRODUCT PLANS", ""
A# 7,8,3, "MF Order IPR Materials", "PM1 P02 EC2 SM1 SD2 $P310"
A# 7,11,4, "MS Hire ISS", "PM1 P01 EC1 SM1 SD1 $P260"
A# 7,12,3, "MD Design IPR Package", "PM1 P01 P02 P01 EC1 $P510 #C800"
A# 7,27,3, "MS Appoint Distributors", "U1 B5 01 EC2 SM2 $P700"
  
```

- (A) Line type (H = heading, A = activity, M = milestone)
- (B) Preceding and succeeding nodes
- (C) Remaining duration
- (D) Activity description
- (E) Resources

PERTMASTER PRECEDENCE PLAN FILE

```

A → H# "PRECEDENCE", "MARKETING A NEW PRODUCT", "Westminster Software Inc.", "Palo Alto
M# 1,1,0, "START"
M# 1,2,0, "F-S"
M# 1,3,0, "F-S"
M# 1,4,0, "F-S"
B → A# 2,2,6, "GM Create IPR Business Plan", "PE2 P01 EC4 SM4 $P460"
B → A# 3,3,4, "GM Develop IPR Marketing Plan", "PE2 P01 EC4 SM4 $P460"
C → A# 3,5,0, "F-S"
C → A# 4,4,3, "GM Develop IPR Design Concepts", "PE2 P01 EC4 SM4 $P460"
C → A# 4,6,0, "F-S"
C → A# 5,5,3, "GM Negotiate License Agreement", "PE1 P01 EC1 SM1 $P260"
D → A# 5,7,0, "F-S"
D → A# 6,6,3, "GM Develop Production Plan", "PE2 P01 EC2 SM2 $P460" ← G
A# 6,7,0, "F-S"
A# 7,7,2, "GM Approve IPR Plans & Design", "PE4 P01 EC2 SM2 $P860"
A# 7,9,0, "F-S"
A# 9,9,3, "GM create and Approve IPR Budget", "PE1 P02 EC2 SM2 SD2 $P320"
E → A# 9,10,0, "F-S"
A# 10,10,3, "GM Appoint IPR Manager", "PE2 P01 EC1 SM1 $P460"
A# 10,11,0, "F-S"
  
```

- (A) Line type (H = heading, A = activity, L = link, M = milestone)
- (B) Activity number
- (C) Link start and finish numbers
- (D) Remaining duration
- (E) Link type
- (F) Activity description
- (G) Resources

HOW PERTMASTER IS CUSTOMIZED

If PERTMASTER has been customized for your computer, which will usually be the case, there will be a file named CUSDATA (with no extension) on the main program disk. This file contains the data which tell PERTMASTER how to format its screen displays and, to a lesser extent, the characters used on printed reports.

If you wish to change any of the parameters in CUSDATA, you may do so by using a text editor, as will be explained later. However, be warned that **THIS SHOULD BE ATTEMPTED ONLY BY AN EXPERIENCED MICROCOMPUTER USER**, since it involves some understanding of computer and terminal control commands.

In a relatively few instances, there will not be a CUSDATA file on your program disk. In such cases, PERTMASTER will run using defaults for each of the parameters which can be controlled via the CUSDATA file. If, for any reason, you want to change any of these parameters, you may do so by creating a CUSDATA file containing the appropriate information.

All of the customization parameters which can be changed by means of the CUSDATA file are discussed in this appendix. When PERTMASTER is first loaded, the system will set all customization parameters to their default values. If there is no CUSDATA file on the disk, these defaults will not be changed, resulting in the basic PERTMASTER displays — no highlighting, no reverse video, no flashing, no color. If a CUSDATA file is present, the parameters contained in the file will override the defaults. The file need contain only those parameters which are to be changed from the defaults.

CHANGING CUSDATA PARAMETERS

A portion of a typical CUSDATA file is shown below.

```
COL0=27/"[0m"  
COL1=27/"[0m"  
COL2=27/"[7m"  
COL3=27/"[1m"  
BOX=" "  
TITLE=" "  
RBOX=" " "  
SAXIS=" " /138/"- "  
SBAR=135  
SCRIT=27/"[1m"/135  
SNEG=27/"[1;5m"/135  
SFLT=95  
SHSTES=27/"[1m"/135  
ESC=9  
LEADIN=31  
LFT=31/195  
RGHT=31/193  
UP=31/192  
DOWN=31/194  
K20=31/225  
K19=31/224  
K4=31/143  
K3=31/198
```

Note that CUSDATA is a simple text file with one parameter per line. Each parameter line consists of an upper-case keyword, followed by an equal sign, and then by an ASCII code or codes which can be specified in one of three ways:

1. Decimal equivalent of the ASCII character, such as 42 for an asterisk (*).
2. Hexidecimal equivalent, preceded by a dollar sign, of the ASCII character, such as \$2A for an asterisk (*).
3. Character string, enclosed in quotes, such as "*".

If necessary, several codes, separated from one another by a slash, can be used to define a parameter. Examples of complete parameter lines are as follows:

```
ESC = 9
RGHT = $1B/$43
COL1 = $7C/"[31m"/00
```

Before making any changes to CUSDATA, be sure to make a back-up copy — just in case! A simple way to do this is to copy it to a new file name, such as CUSDATA.BAK, which will be ignored by PERTMASTER but which can always be renamed or recopied back to CUSDATA.

Using a text editor, you can change any of the parameters in CUSDATA. You can also add parameters that you may want to change from the default values shown in the following paragraphs. If any of these involve color, reverse video, highlighting, lowlighting, flashing, or graphics, you must refer to the computer manuals which define the codes that control these features.

If CUSDATA does not exist on your program disk, use a text editor to create a new file having that name. (Do not add a period or an extension to the name.) Then enter only those parameters that you wish to change from the default values.

TERMINAL CUSTOMIZATION

The parameters which may be used to customize your terminal are listed in the following table.

| <i>Keyword</i> | <i>Definition and Notes</i> | <i>Default</i> |
|----------------|--|----------------|
| BELL | Terminal Alarm: Causes terminal “beep.” | 7 |
| SBACK | Screen Backspace: Allows PERTMASTER to move the cursor one position to the left without blanking existing characters. Must be set to the value required by the terminal in use if value is other than the default value. | 8 |

Note

The next five parameters allow the program to set screen colors. They can also be used on some monochrome terminals to set highlighting, lowlighting, inverse video, and flashing.

| | | |
|------|--|------|
| COL0 | Exit Color: Color which is considered normal for terminal when PERTMASTER exits. | None |
| COL1 | General Text Color: Color used for most of text on screen and for background when clearing screen. | None |
| COL2 | Heading/Footing Color: Color of heading and help boxes, and axis blocks on screen reports. | None |
| COL3 | Input Box Color: Color of screen areas used for input entries. | None |
| L25 | Function Key Boxes: Color of function key label boxes displayed on line 25. Key labels are displayed in General Text Color (COL1). If L25 is set to default null, line 25 is not displayed. (Refer to Keyboard Customization paragraph.) | None |

SCREEN AND PRINTER CHARACTER CUSTOMIZATION

The following table lists the parameters which may be used to specify certain characters which appear on the terminal or which are used on printed reports.

| <i>Keyword</i> | <i>Definition and Notes</i> | <i>Default</i> |
|----------------|--|----------------|
| TITLE | Title Box: Characters used to make PERTMASTER title box. See Figure E-1. | “/\<>” |
| BOX | Heading Boxes: Characters used to make left and right heading boxes. See Figure E-2. | “*****” |
| RBOX | Report List Box: Character used to make sides of Reports Ordered So Far: box on Report Menu. If COL2 is used, box is bordered by that color; therefore RBOX should be set to a space (“ ”). | “!” |
| PBAR | Printed Bar, Non-critical: Character used on printed barchart for non-critical activities. | “=” |
| PCRIT | Printed Bar, Critical: Character used on printed barchart for critical activities. | “C” |
| PNEG | Printed Bar, Negative Float: Character used on printed barchart for activities with negative float. | “N” |

| | | |
|--------|--|-------------|
| PFLT | Printed Float: Character used on printed barchart for float. | “.” |
| PHSTES | Printed Early-Start Histogram: Character used to create blocks on early-start histograms. | “*” |
| PHSTLF | Printed Late-Start Histogram: Character used to create blocks on late-start histograms. | “#” |
| PHSTCM | Printed Cashflow: Character used for data points on printed cash-flow curves. | “+” |
| SAXIS | Screen Report Axis: Characters used to make up axis on Screen Report. See Figure E-3. | “- = V!!!!” |
| SBAR | Screen Bar, Non-critical: Character used for non-critical activities on Screen Barchart. Code can be prefixed by color control code to set color of bar. | “=” |
| SCRIT | Screen Bar, Critical: Same as SBAR, except used for critical activities. | “C” |
| SNEG | Screen Bar, Negative Float: Same as SBAR, except used for activities with negative float. | “N” |
| SFLT | Screen Float: Same as SBAR, except used for float. | “.” |
| SHSTES | Screen Histogram Block: Character used to create Screen Histogram blocks. Can be prefixed by color control code to set color of blocks. | “*” |

The TITLE character string consists of eight ASCII characters. Consider the characters to be numbered from 1 to 8, from left to right.

The title box will be formed using these characters, positioned as follows:

```
51212121212126
3 PERTMASTER 4
72121212121218
```

For default TITLE="/<>" , the heading boxes will appear as follows:

4 spaces

```
  \/\\/\\/\\/\
<  PERTMASTER  >
  \/\\/\\/\\/\
```

Figure E-1. Title Box

The BOX character string consists of six ASCII characters. Consider the characters to be numbered from 1 to 6, from left to right.

The heading boxes will be formed using these characters, positioned as follows:

```
3111111111111111111111111114
2                                     2
2                                     2
2                                     2
2                                     2
5111111111111111111111111116
```

For default BOX="*****" the title box will appear as follows:

```
*****
*                                     *
*                                     *
*                                     *
*                                     *
*****
```

Figure E-2. Heading Box

The SAXIS character string consists of seven ASCII characters. Consider the characters to be numbered from 1 to 7, from left to right.

The Screen Barchart axis will be formed using these characters, positioned as follows:

```

        6
1111S S1111532222222232222222322S
        7
        7
        7
        7
        S
        7
        7
    
```

For default SAXIS="-=V! !!!", the Screen Report axis will appear as follows:

```

-----S S-----!V=====V=====V==S
        !
        !
        !
        S
        !
        S
        !
    
```

On the Screen Histogram, all characters 7 are replaced by characters 4. Therefore, the default Screen Histogram axis will look the same as above, since the 4th and 7th characters are identical.

On the Screen List, all characters 3 are replaced by characters 2. Therefore, the default Screen List axis will appear as follows:

```

-----S S-----!=====V=====V==S
        !
        !
        !
        S
        !
        S
        !
    
```

Figure E-3. Screen Report Axis

KEYBOARD CUSTOMIZATION

Only the ◀**ESCAPE**▶ key, the Screen Report window keys, and the function keys (if any) on your keyboard may be customized. The information required to accomplish these changes appears below.

Keyword: LEADIN

Definition: Control Key Lead-in

Default: " "

Keyboards used on most computers will produce two character codes if any of the special command keys (e.g. arrow keys) pressed. The first of these codes will usually be the same for all of the commands produced by the special command key, but will be different for each command key. The control key lead-in instructs the software to wait for a second character from the keyboard and to interpret it as a command key.

A few computers use sequences which are longer than two characters for special command keys. If this is the case with the computer that you are using, these keys cannot be defined within **PERTMASTER**; you will have to use the default keys that are given.

If special command keys are to be used, **LEADIN** should be set to the appropriate lead-in character. Any key which is changed to one which uses the lead-in must have the key designation prefixed with the lead-in character. The lead-in should not be specified, however, if the computer operating system returns both characters together to the software (e.g. **IPM PC** or compatible computers).

The Screen Report keys, listed in the table below, are used to move the window when the Screen Report is displayed. If the defaults for these keys are changed, the values should be set to arrow keys because the arrow keys will be defined on the help screen in place of the default keys, even if only one of the keys is changed.

| <i>Keyword</i> | <i>Definition and Notes</i> | <i>Default</i> |
|----------------|--|----------------|
| RGHT | Right: Scrolls the Screen Report window to the right. | "D" |
| LFT | Left: Scrolls the Screen Report window to the left. | "S" |
| UP | Up: Moves the Screen Report window down 19 lines. | "E" |
| DOWN | Down: Moves the Screen Report window up 19 lines. | "X" |
| ESC | ◀ESCAPE▶ Key: Should be changed only if your keyboard does not have an ▶ESCAPE▶ Key. PERTMASTER's screen displays and legends will not change, so that you must be aware of the key to be used in place of ▶ESCAPE▶. | \$1B |

If your computer keyboard has function keys, PERTMASTER may or may not have been supplied with those keys customized. This depends on the computer which you are using. Within certain limits, you can change the functions of those keys, or assign functions to them if they have not been customized.

The following table lists the functions that may be assigned. Keywords K1 through K10 define functions that vary, depending on their use in the program. Keywords K11 through K18 are reserved, and may not be used. Keywords K19 and K20 define functions that do not change throughout the program.

The default for each of the parameters in the table is null ("").

| <i>Key-word</i> | <i>Input Function</i> | <i>Screen Report Function</i> | <i>General Function</i> |
|--------------------|-----------------------|-------------------------------|-------------------------|
| K1 | Display descriptions | Select barchart | Menu entry #1 |
| K2 | Display resources | Select histogram | Menu entry #2 |
| K3 | Insert | Select listing | Menu entry #3 |
| K4 | New page | Go to activity | Menu entry #4 |
| K5 | Change headings | New start day number | Menu entry #5 |
| K6 | Go to top of plan | Change resource | Menu entry #6 |
| K7 | | Next resource | Menu entry #7 |
| K8 | | Go to top of chart | Menu entry #8 |
| K9 | | Go up one page | |
| K10 | | Go down one page | |
| K11 thru K18 | } (Reserved) | | |
| K19 | | | ◀ESCAPE▶ (cancel) |
| K20 | | | Help |

Corresponding to each of the function parameters in the preceding table are twenty additional parameters having keywords KL1 through KL20. These keywords define the Key Labels of twenty function keys. Each of these also has a null default.

Functions are assigned to function keys in the following manner. Set the function parameter value to the control character(s) sent from the keyboard by the key you wish to assign. Then set the corresponding key-label parameter to the label that is on the function key.

As an example, assume that you want to assign the function that is defined by keyword K9 to function key F6. Also assume that your computer manual tells you that function key F6 generates a character sequence of ESC 6. (ESC 6 is equivalent to decimal 27 54 and to hexadecimal 1B 36.) Therefore, you would enter the following in the CUSDATA file:

| | |
|--|--|
| LEADIN = 27 (or \$1B) | [See beginning of section] |
| K9 = 27/54 (or \$1B/\$36) | [Character sequence for function key F6] |
| KL9 = "6" | [Function key F6 label] |

Note that it is not necessary to enter the "F" prefix for the function key. In fact, the function-key labels should be kept as short as possible. If they are too long, the labels displayed on the twenty-fifth line may overflow, causing a program error. Also, remember that keyword L25 must be set to a value other than null if the twenty-fifth line is to be displayed; refer to the paragraph covering Terminal Customization.

PROGRAM CONTROL CUSTOMIZATION

The number of disks that are used to run PERTMASTER can be changed from the program as it is supplied, although the configuration that is supplied will generally be the optimum for your computer. You can also change a delay factor within the program, which will be explained at the end of this section.

The individual disk files which comprise PERTMASTER are grouped as shown below. The files marked with an asterisk (*) in Group 0 are optional, depending on the computer for which PERTMASTER was supplied. The extension .EXE applies to MS/DOS; for CP/M-80 versions, the extension will be .COM.

| <i>Group 0</i> | <i>Group 1</i> | <i>Group 2a</i> | <i>Group 2b</i> | <i>Data</i> |
|----------------|----------------|-----------------|-----------------|-------------|
| BASRUN.EXE | CONTROL.MEN | ANAP.EXE | CALNET.EXE | ABBREV.COD |
| CONTROL.EXE | CONTROL1.EXE | ANNETTE.EXE | CALNET.MEN | DAILY.CAL |
| *CUSDATA | HEADNET.EXE | BARNET.EXE | CODES.EXE | INDEX |
| ERRMSG | MAKENET.EXE | DISKNET.EXE | CODES.MEN | MARKET.0 |
| HELP | PNET.EXE | HISTPRNT.EXE | MERGE.EXE | PRODUCT.0 |
| *INSTALL.EXE | | LISTNET.EXE | | |
| SERIAL.NUM | | PRINNET.EXE | | |
| SPARAM | | PRNTMSTR.EXE | | |
| SYSDNET.EXE | | PRNTMSTR.MEN | | |
| *TERMS | | RESOURCE.EXE | | |
| *TERMDATA | | SCREENET.EXE | | |
| TRANNET.EXE | | | | |

PERTMASTER will be supplied on a single disk or on multiple disks, with the content of each disk as follows.

| <i>Type of System</i> | <i>Disk Label</i> | <i>File Groups On Disk</i> |
|---------------------------|-------------------|----------------------------|
| Single-disk | 1 | 0 + 1 + 2a + 2b + Data |
| Two-disk (large capacity) | 1 | 0 + 1 + 2a + 2b |
| | DATA | Data |
| Two-disk (small capacity) | 1 | 0 + 1 + 2a |
| | 2/DATA | 2b + Data |
| Three-disk | 1 | 0 + 1 + 2b |
| | 2 | 2a |
| | DATA | Data |
| Four-disk | 1 | 0 |
| | 2 | 1 + 2b |
| | 3 | 2a |
| | DATA | Data |

Except for the DATA disk, the parameters listed below determine the disk which PERTMASTER searches to find the files that are called within the program. The Data Drive is set in PERTMASTER's Housekeeping facility; see Reference Section 5.4.

| <i>Keyword</i> | <i>Definition and Notes</i> | <i>Default</i> |
|----------------|--|----------------|
| PDR0 | Program Drive 0: Assigns drive for files in Group 0. | None |
| PDR1 | Program Drive 1: Assigns drive for files in Group 1. | None |
| PDR2 | Program Drive 2: Assigns drive for files in Group 2. | None |

When these parameters are unchanged from their defaults, and a multiple-disk system is being used, PERTMASTER will instruct you to insert the correct disk (0, 1, or 2) in the default drive when a file is not found on the disk which is presently in that drive. However, this can be changed by assigning the appropriate drive identifier to one of the above parameters. In that case, PERTMASTER will first search the disk in the specified drive for a missing file from the group. If the file is not on that disk, then the change-disk instruction will appear on the screen.

As an example, let's assume that you have a four-disk version of PERTMASTER and that you have up-graded your computer to two high-density disk drives. This will allow you to put all of the program files on Disk 1 and use that disk in drive A. The disk in drive B need only hold your data files.

To implement this change, you must instruct PERTMASTER to look for all program files on drive A. First, copy all of the files in Groups 0, 1, 2a, and 2b to a new high-density disk. Then enter the following Program Drive values in the CUSDATA file

PDR0 = "A:"

PDR1 = "A:"

PDR2 = "A:"

which tells PERTMASTER to search the disk in drive A for all files in Groups 0, 1, and 2. After that, change your Data Drive from D: to B:, using the Housekeeping option, "Change Other System Details."

Note the following:

1. The files in Groups 0, 1, and 2a must be moved as complete blocks. The files in Group 2b, however, can be moved separately as long as CALNET.EXE (or .COM) and CALNET.MEN both reside on the same disk, and CODES.EXE (or .COM) and CODES.MEN are both on the same disk.
2. The files ERRMSG and HELP must appear on each program disk. They are not needed on the DATA disk.

The other program control parameter which can be changed is:

Keyword: DELAY
Definition: Delay Factor
Default: "100"

This parameter determines the amount of delay that is inserted at certain points within the program. It may be varied to accommodate the speed of execution of a particular computer. Increasing the parameter value increases the delay introduced, while decreasing the value reduces the delay.

The effect of this factor is most apparent on the delay which occurs when either the Screen Barchart or Screen Histogram is scrolled horizontally. The value may have to be increased if the dates at the top of the report, or the body of the report, change before the left or right scrolling keys can auto-repeat. This will be evidenced by dates which are not in the proper sequence.

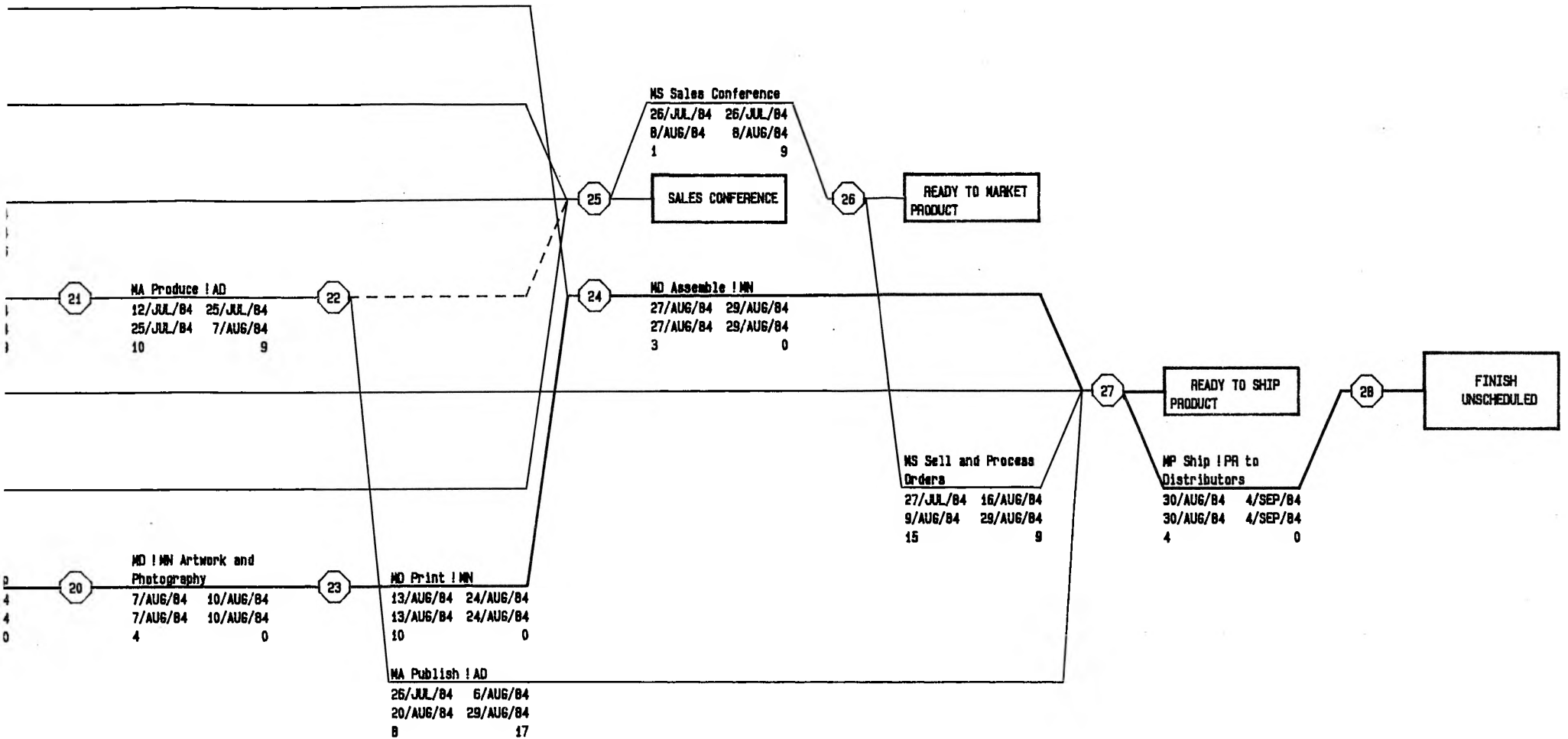

symbol 1-53, 92, 96, 123; 2-34, 49, 84
\$ symbol 1-53, 92, 95, 122; 2-34, 49, 84
= symbol 1-96; 2-50
A-prompt 1-11, 24, 61
Abandoning changes 1-52, 91; 2-30
Abandon printing of reports 2-34
ABBREV.COD file 1-10, 26, 53, 62, 92, 99
Abbreviations 1-26, 30, 52, 62, 67, 91, 94; 2-7, 10, 16, 84
Abbreviations change/display menu 2-90
Abbreviations code-name 1-28, 65; 2-7, 24
Abbreviations file name 2-87
Abbreviations file, copy 2-86
Abbreviations file, delete 2-85
Abbreviations file, dummy 1-53, 92, 128
Abbreviations file, new 2-87
Abbreviations files 1-62, 127; 2-87
Abbreviations menu 2-85
Abbreviations, activity 1-127; 2-84
Abbreviations, change or add 2-89, 90
Abbreviations, descriptions 2-87
Abbreviations, display 2-89, 91
Abbreviations, print 2-92
Abbreviations, resource 1-127; 2-84
Abtex Software, Ltd. 1-2
Activities and links, maximum number 1-70
Activities and relationships, list of 1-116; 2-33
Activities, adding and deleting 1-48, 86; 2-24
Activities, critical 1-21, 42, 58, 80, 107, 120; 2-38, 42, 45, 54, 60, 65
Activities, entering 1-25, 66; 2-9, 15
Activities, non-critical 1-42, 80, 107, 120; 2-45, 61, 64
Activity description 1-33, 67; 2-10, 16
Activity duration 1-19, 30, 55, 96, 100; 2-10, 16
Activity listing 1-116
Activity numbers 1-30, 67, 70; 2-16
Activity, closely linked 2-28
Activity-on-arrow network 1-7
Activity-on-node network 1-7
Adding abbreviations 2-90
Adding activities 1-48, 86
Adding milestones 1-49, 87
Adding starts and finishes 1-49, 88
Alphabetical sequence 2-41, 53, 64
Alphabetic sorting 2-37, 41, 53, 64
Analysis, reports 1-102
Application programs 1-115
Arrow keys 2-57; E-8
Arrow network 1-7
Arrow notation 1-19
Arrow plan 1-7
Arrow plan entry display 1-29; 2-9

Arrow plan, new 1-22; 2-9
ASCII codes 2-68, 70, 93
Automatic scaling 1-123; 2-51
B-command 2-58
Back-up disks 1-10
Background information 1-5, 12
Backward pass 1-102
Barchart report alphabetic sorting menu 2-41
Barchart report menu 1-41, 78; 2-40, 45
Barchart report selective reporting menu 1-40, 78; 2-43
Barchart report sort option menu 1-40, 78; 2-40
Barchart symbols 1-42, 80; 2-45
Barchart, period 1-40, 42, 78, 80, 120; 2-33, 40, 46
Barchart, project 1-40, 78, 120; 2-33, 40, 46
Barchart, screen 1-36, 75, 108; 2-55
Barcharts, float option on 1-17; 2-96
Boldface type 1-4
C-command 1-113; 2-58
Calendar 1-26, 50, 62, 89, 127; 2-7, 74
Calendar change/display menu 2-80
Calendar code-name 1-28, 65; 2-7, 24
Calendar date 1-50, 89; 2-76, 81
Calendar file name 1-26, 62; 2-76
Calendar file, copy 2-75
Calendar file, delete 2-75
Calendar file, new 2-76
Calendar files 1-127
Calendar menu 1-127; 2-74
Calendar range 2-76
Calendar, change 2-79, 80
Calendar, display 2-79, 80
Calendar, print 2-83
Calling up PERTMASTER 1-24, 60; 2-2
Care and handling of disks 1-9
Cash flow curve 1-95, 123; 2-49
Change abbreviations 2-89, 90
Change calendar file 2-79
Change commands 1-46, 84; 2-21
Change display, plan parameters 1-51, 90; 2-23
Change histogram command 1-113; 2-57
Change printer details 1-18; 2-92
Change resource command 1-113; 2-58
Changes, plan 1-45, 83; 2-5, 21
Changes, saving or abandoning 1-52, 91; 2-30
Changing activity durations 1-47, 85; 2-22
Changing link durations 1-85, 2-22
Changing plan headings 1-51, 90; 2-22
Changing plan identification 1-51, 90; 2-23
Changing resources 1-99; 2-26
Changing starts and finishes 1-50, 89
Characters per printed line 2-93
Chronological order of activities 2-37, 41; 2-52
Closely linked activity 2-28
Code-name, abbreviations 1-28, 65; 2-7, 24
Code-name, calendar 1-28, 65; 2-7, 24
Codes, resource 1-94, 112; 2-27, 58

- Command line 1-46, 84; 2-27
- Commands, change 1-46, 84; 2-21
- Commands, screen report 1-110; 2-57
- Complete resources report 1-101, 122; 2-33, 47
- Complex relationships 1-19, 56
- Computer hardware requirements 1-1
- Computer memory 2-10, 16
- Computer memory, factors affecting 1-128
- Configuring PERTMASTER disk to computer 1-10
- Configuring PERTMASTER to computer 1-10
- Conventional resources 1-95, 123; 2-34
- Copy abbreviations file 2-86
- Copy calendar file 2-75
- Copy plans 2-99
- Copyright notice 1-12, 24, 61
- Correcting plans 1-32, 71
- CPA 1-5
- CPM 1-5
- CP/M-80 1-1, 10
- Critical activities 1-21, 42, 58, 80, 107, 120; 2-38, 42, 47, 54, 60, 65
- Critical path 1-21, 58, 102
- Critical path analysis 1-5
- Critical path method 1-5
- Curve, S 1-95, 123; 2-49
- Curve, cash flow 1-95, 123; 2-49
- CUSDATA file E-1
- CUSDATA parameters, changing E-2
- Customization, keyboard E-8
- Customization, program control E-10
- Customization, screen and printer characters E-4
- Customization, terminal E-3
- Customizing PERTMASTER E-1
- D-command 1-33, 48, 71, 86; 2-24
- DAILY.CAL file 1-10, 26, 28, 62, 65
- Daily resources report 2-47
- Data base 1-115
- Data disk 1-10, 17, 24, 51, 60, 90, 103; 2-5, 30
- Data drive 1-17; 2-95
- Database programs, transferring files to D-1
- Date, calendar 1-50, 89; 2-76, 81
- Day number 1-31, 50, 69, 89; 2-12, 18
- Day, non-working 2-77
- Day, working 2-77
- dBASE II and III, transferring files to D-1
- Default drive 1-11, 24, 34, 61, 72, 103
- Delay factor E-13
- Delete command 1-33, 48, 71, 86; 2-24
- Delete plans menu 2-97
- Deleting abbreviations file 2-85
- Deleting activities 1-48, 86; 2-24
- Deleting calendar file 2-75
- Deleting links 1-86; 2-24
- Deleting plans 2-30, 97
- DES-command 1-98; 2-24
- Description, activity 1-30; 2-10, 16
- Description, key word 1-113

Descriptions command 1-98; 2-24
Descriptions, abbreviations 2-87
Directory 2-5
Disk drives 1-1, 10
Disk file 1-104; 2-61
Disk report 1-104, 115; 2-34, 61
Disk report menu 2-61
Disk report selective reporting menu 2-66
Disk, data 1-10, 17, 24, 51, 90, 103; 2-5, 30
Disks, back-up 1-10
Disks, care and handling 1-9
Display abbreviations 2-89, 90, 91
Display calendar 2-82
Dooley, Arch R. 1-8
Drive, data 2-95
Dummy abbreviations file 1-53, 92, 128
Dummy activities 1-21, 31; 2-11
Duration, activities 1-19, 30, 55, 96, 100; 2-10, 16
Duration, links 1-55, 57
Durations, changing 1-47, 85; 2-22
Dusenbury, Warren 1-8
Early start histogram 2-50
Early start resources disk report 2-61
Early start resources report 1-122; 2-47
Entering activities 1-29, 66; 2-9, 15
Entering resources 1-99; 2-26
Entry display, arrow plan 1-29; 2-9
Entry display, precedence plan 1-66; 2-15
Error messages B-1
Executive type-ahead C-1
Expendable resources 1-95, 99, 122; 2-34
F-command 1-130; 2-2, 4, 31, 59, 72
File, indexing 1-10
Files, program 1-10
Files, sample 1-10
Finish day 1-127
Finish node 2-10
Finish-to-finish link 1-57, 68; 2-17
Finish-to-start link 1-56, 68, 87; 2-17
Finishes 1-30, 49, 67, 69, 88; 2-11, 18
Finishes, adding 1-49, 88
Finishes, changing 1-50, 90
Float 1-7, 21, 39, 58, 77, 80, 102, 107, 122, 123; 2-39, 44, 45, 56, 60, 67
Float option on barcharts 1-17; 2-98
Float, maximum 1-115; 2-39, 44, 56, 67
Float, negative 1-107, 120; 2-45
Floppy-disk drive 1-11, 24, 60
Format, plan 1-28, 51, 65, 90; 2-7, 24
Forward pass 1-102
Free space 1-130; 2-2, 4, 31, 59, 72
Free space command 1-130; 2-2, 4, 31, 59, 72
Function keys 1-110; E-9
G-command 1-46, 84, 99, 113; 2-25, 59
Gantt chart 2-33
Go-to command 1-46; 2-25, 59
Graphic network 1-6, 45, 83

H-command 1-51, 90, 2-22
Hard-disk drive 1-11, 24
Headings change command 1-51, 90; 2-22
Help 1-25, 62
Help menu, change commands 1-45, 84; 2-22
Help menu, screen report 1-110; 2-57
Histogram menu 2-49
Histogram scaling 2-50
Histogram, early start 2-50
Histogram, late start 2-50
Histogram, resource 1-96, 122; 2-33, 49
Histogram, screen 1-112; 2-58, 60
Housekeeping 1-126; 2-3, 72
Housekeeping menu 1-16, 126; 2-72
How to use this manual 1-3
I-command 1-33, 48, 49, 71, 86, 88; 2-22
Identification, plan 1-25, 51, 62, 90; 2-6, 23
INDEX file 1-10; 2-100, 101
Indexing 1-10
Initialization characters, printer 2-93
Insert command 1-33, 48, 71, 86; 2-22
Keyboard customization E-8
L-command 1-111; 2-58
Lag link 1-57
Lang, Douglas W. 1-8
Large numbers 1-96
Late start histogram 2-50
Late start resources disk report 2-62
Late start resources report 1-122; 2-48, 62
Lead link 1-57
Lead-in E-5
Levy, Ferdinand K. 1-8
Library networking 2-23
Line, number of characters 2-93
Lines per printed page 2-92
Link, finish-to-finish 1-57, 68, 88; 2-17
Link, finish-to-start 1-56, 68, 87; 2-17
Link, lag 1-57
Link, lead 1-57
Link, start-to-start 1-57, 68; 2-17
Links 1-55, 67; 2-16, 17
Links, adding and deleting 1-86; 2-25
Links, duration 1-57; 2-16
List of activities & relationships 1-116; 2-33
List, screen 1-111; 2-58, 59
Loading PERTMASTER 1-24, 60; 2-2
Logic, plan/network 1-104, 116
Lotus 1-2-3, transferring files to D-2
M-command 2-5
Main menu 1-14, 24, 61, 103; 2-2
Making changes 1-45
Manual load 2-5
Margin, top 2-93
MARKET plan 1-10, 26, 47, 63
Maximum float 1-115; 2-39, 44, 56, 67
Maximum number, activities and links 1-70

- Memory available (see Free space)
- Memory, computer 1-128; 2-10, 16
- Memory-full message 1-128
- Menu, abbreviations 2-85
- Menu, abbreviations change/display 2-90
- Menu, barchart report 1-41, 78; 2-40, 45
- Menu, barchart report alphabetic sorting 2-41
- Menu, barchart report selective reporting 1-40, 78; 2-43
- Menu, barchart report sort option 1-40, 78; 2-40
- Menu, calendar 1-127; 2-74
- Menu, calendar change/display 2-80
- Menu, change commands help 1-46; 2-21
- Menu, delete plans 2-97
- Menu, disk report 2-61
- Menu, disk report selective reporting 2-66
- Menu, histogram 2-49
- Menu, housekeeping 1-16, 126; 2-72
- Menu, main 1-14, 24, 61, 103; 2-2
- Menu, merge plans 2-101
- Menu, new plan 1-27, 64; 2-6
- Menu, printer change 2-92
- Menu, report 1-35, 73, 104; 2-32
- Menu, resources report 2-47
- Menu, save/abandon plan 1-34, 72, 103; 2-29
- Menu, screen report alphabetic sorting 1-106; 2-53
- Menu, screen report help 1-110; 2-57
- Menu, screen report selective reporting 1-37, 75, 107, 114; 2-55
- Menu, screen report sort option 1-36, 74, 105; 2-52
- Menu, standard report alphabetic sorting 2-36
- Menu, standard report selective reporting 1-40; 2-38
- Menu, standard report sort option 1-40; 2-35
- Menu, system details 1-17; 2-97
- Menu, time analysis disk report 2-63
- Menu, time analysis disk report alphabetic sorting 2-64
- Menu, time analysis disk report sort option 2-63
- Merge plans menu 2-101
- Merging plans 1-129; 2-101
- Merging, rules 2-103
- Milestone report 1-119; 2-39
- Milestones 1-70; 2-13, 19, 38
- Milestones, adding 1-49, 87
- MS-DOS 1-1, 10
- Multiple resources on report 1-96; 2-50
- N-command 1-113; 2-59
- Name, abbreviations file 2-87
- Name, calendar file 1-26, 62
- Negative float 1-107, 120; 2-45, 60
- Network analysis 1-1, 5
- Network listing 1-116; 2-33
- Network logic 1-116
- Networking, library 2-23
- New abbreviations file 2-87
- New arrow plan 1-19; 2-9
- New calendar file 2-77
- New plan menu 1-27, 64; 2-6
- New plan resource display 2-26

New precedence plan 1-59; 2-15
New start day command 1-113; 2-57
Node activity number 1-17
Node, finish 2-10
Node, preceding 2-10
Node, start 2-10
Node, succeeding 2-10
Node/activity number on reports 2-96
Nodes 1-19, 30
Non-critical activities 1-42, 80, 107, 120; 2-45, 60
Non-working days 1-120, 127; 2-77
Non-working days, special 2-81
Normal working week 2-77
Notation, arrow 1-19
Notation, precedence 1-55
Offset value 2-102
Old plans, remove from disk 2-30
Pass, backward 1-102
Pass, forward 1-102
Path, critical 1-21, 58
PC DOS 1-1, 10
Period barchart 1-40, 78, 80, 120; 2-33, 40, 46
PERT 1-5
PERTMASTER files E-11
Plan changes 1-45, 83; 2-5, 21
Plan format type 1-28, 51, 65, 90; 2-7, 24
Plan headings, changing 1-51, 90; 2-22
Plan identification 1-25, 51, 62; 2-6, 23
Plan identification, changing 1-62, 90; 2-23
Plan logic 1-104
Plan parameters change display 2-23
Plan, incorporating resources 1-97; 2-24
Plan, new 2-4, 6
Plan, renumber 2-102
Plan, unanalyzed 1-116
Plan, up-to-date 2-4
Plans list display 1-26, 63; 2-4
Plans, copying 2-99
Plans, correcting 1-32, 71
Plans, deleting 2-30
Plans, merging 1-129; 2-101
Plans, sample 1-26, 63
Point resources 1-96, 99, 123
Precedence network 1-7
Precedence notation 1-55
Precedence plan 1-7
Precedence plan entry display 1-66; 2-15
Precedence plan, new 1-59; 2-15
Preceding node 2-10
Print abbreviations 2-91
Print calendar 2-83
Printed page, lines per 2-92
Printed reports 1-40, 78, 115; 2-31
Printer 1-2, 40, 78, 94; 2-92
Printer change menu 2-92
Printer character customization E-4

Printer details 1-18; 2-92
Printer details, change 2-92
Printer initialization characters 2-93
PRODUCT plan 1-10, 26, 63, 85
Program control customization E-10
Program evaluation and review technique 1-5
Program files 1-10
Project barchart 1-40, 78, 120; 2-33, 40, 46
Project requisites 1-6
R-command 1-112; 2-58
Range, calendar 2-76
References 1-8
Relationship between activities 1-19, 55
Remove old plans from disk 2-30
Renummer plan 2-102
Report analysis 1-102
Report menu 1-35, 73, 104; 2-32
Report titles 1-27, 64; 2-6, 24
Report, disk 1-104, 115; 2-34
Report, early start resources disk 2-61
Report, late start resources disk 2-62
Report, milestone 1-119; 2-39
Report, multiple resources 1-96; 2-50
Report, resources 1-101, 122; 2-34, 47
Report, resources disk 2-71
Report, screen 1-34, 72, 104; 2-34, 52
Report, standard 1-42, 80, 119; 2-32, 35
Report, time analysis disk 2-61, 63, 68
Reports 1-102; 2-31
Reports, node/activity number on 1-17; 2-96
Reports, printed 1-40, 78, 115; 2-31
RES-command 1-97, 99; 2-24
Resource abbreviations 1-127; 2-84
Resource codes 1-94, 112; 2-27, 58
Resource display, new plan 1-100; 2-26
Resource histogram 1-122; 2-33, 49
Resource tracking 1-53, 93, 94
Resources 1-93
Resources command 1-97, 113; 2-24
Resources disk report 2-71
Resources report 1-101, 122; 2-34, 47, 70
Resources report menu 2-47
Resources report, daily 2-47
Resources report, weekly average 2-48
Resources, conventional 1-95, 123; 2-34
Resources, entering and changing 1-99; 2-26
Resources, expendable 1-95, 99, 123; 2-34, 84
Resources, incorporating in plan 1-97; 2-27
Resources, point 1-96, 99, 123; 2-84
Resources, summing 1-123; 2-50
Resources, too many 2-28
Resources, types of 1-95
S-curve 1-95, 123; 2-49
Sample files 1-10
Sample plans 1-26, 63
Save/abandon plan menu 1-34, 72, 103; 2-29

- Saving changes 1-52, 91; 2-29
- Scaling, automatic 1-123; 2-51
- Scaling, histogram 2-50
- Scheduled starts and finishes 1-30, 49, 67, 69, 88; 2-11, 18
- Screen barchart 1-36, 75, 108; 2-55
- Screen barchart command 2-59
- Screen character customization E-4
- Screen histogram 1-112; 2-58, 60
- Screen histogram command 2-58
- Screen list 1-111; 2-58, 59
- Screen list command 1-111; 2-59
- Screen report 1-34, 72, 104; 2-34, 52
- Screen report alphabetic sorting menu 1-106; 2-53
- Screen report help menu 1-110; 2-57
- Screen report selective reporting menu 1-37, 75, 107; 2-55
- Screen report sort option menu 1-37, 74, 105; 2-52
- Scrolling 1-110; 2-57
- Selection key 1-107, 115; 2-13, 20, 38, 43, 55, 66
- Selective reporting 1-113; 2-13, 19, 66
- Slack 1-7
- Sorting 2-37, 41, 53
- Specifications and description A-1
- Spread sheet 1-115
- Standard report alphabetic sorting menu 2-37
- Standard report listing 1-40, 78, 80, 119; 2-32, 35
- Standard report selective reporting menu 1-40, 78; 2-38
- Standard report sort option menu 1-40, 78; 2-35
- Start node 2-10
- Start-to-start link 1-57, 68; 2-17
- Starting PERTMASTER 1-9
- Starting day 1-127
- Starting location 1-106, 115; 2-36, 39, 41, 46, 53, 56, 64, 67
- Starts 1-30, 49, 67, 88; 2-17, 18
- Starts, adding 1-49, 88
- Starts, changing 1-50, 89
- Sub-time units 2-7, 16, 24, 39, 78
- Succeeding node 2-10
- Summing similar resources 1-123; 2-50
- SuperCalc, transferring files to D-3
- Support, technical 1-2
- System details menu 1-17; 2-95
- System details, change 1-17; 2-95
- Technical support 1-2
- Terminal customization E-3
- Terminal, video 1-2
- Thompson, Gerald L. 1-8
- Time analysis disk report 2-61, 63, 68
- Time analysis disk report alphabetic sorting menu 2-63
- Time analysis disk report menu 2-63
- Time analysis disk report sort option menu 2-63
- Time constraints 1-33, 55, 49, 88
- Time now day number 1-32, 52, 70, 91; 2-25, 27
- Time periods, non-calendar 1-127; 2-78, 82
- Time units per day 1-28, 65; 2-7, 24, 78
- Titles, report 1-27, 64; 2-7, 24
- Transferring PERTMASTER files D-1

Type-ahead C-1
Typefaces used in manual 1-4
Unanalyzed plan 1-116
Unscheduled starts and finishes 1-30, 49, 67, 69, 88; 2-11, 18
Version number 2-5, 9, 15, 23
Video terminal 1-2
Weekly average resources report 2-48
West, Jerome D. 1-8
Westminster Software, Inc. 1-2
What to read 1-3
Wildcard 1-96; 2-50
Working days 2-77
Working days, special 2-82
Working week, normal 2-76

PERTPLOTTERTM

Westminster
oftware

PERTPLOTTER is dedicated to the memory of
John Harris,
one of its principal authors
and our friend.
He is sadly missed.

Program written by
George Angwin, Debbie Entinger, John Harris,
Daryll Hernandez, Kon Lovett, and Hiu Man Ng

Program produced and marketed by
Westminster Software, Incorporated
660 Hansen Way
Suite 2
Palo Alto, California 94304
Phone: (415)424-8300
Telex: 759818 WESTMINSTER MP

Program owned by
Abtex Software, Ltd.
11 Campus Road
Listerhills Science Park
Bradford BD7 1HR
Great Britain
Phone: (44)274-734838

User's Guide and Reference Manual written by
Susan Frahm Modlin

©Copyright 1984 by Westminster Software Incorporated

CUSTOMER LICENSE AGREEMENT

This document is a non-exclusive, non-transferable license to use the PertPlotter Software (the "Software") and related Documentation (the "Documentation"). It is granted by Abtex Software Ltd. (Abtex). It is valid upon your opening and use of the package containing the Software; however, no support or assistance will be given until the registration card enclosed with the Software has been signed and returned to Westminster Software Incorporated ("Westminster"), 660 Hansen Way, Suite 2, Palo Alto, California 94304. The license is granted subject to the following terms and conditions.

OWNERSHIP The Software and Documentation are owned and shall remain the property of Abtex, and the ideas and expressions contained therein are proprietary information in which you have no interest and no right to use except as granted by this license.

BACKUP POLICY Abtex (or Westminster acting as agents for Abtex) will supply a registered user with a backup copy of the Software if required, on payment of a nominal fee for copying, packing and shipping charges.

RESTRICTIONS ON USE AND TRANSFER The original and any backup copies of the Software and Documentation are to be used only in connection with a single computer by the registered user. This condition may be varied in writing by Abtex. You may physically transfer the Software from one computer to another provided that the Software is only used in connection with one computer to another over a network. You may not copy the Software except that you may load the Software into the computer as an essential step to executing the program. You may not copy the Documentation in any manner whatsoever. Neither the software nor the Documentation may be modified, or translated without prior written permission from Abtex.

NO WARRANTY Abtex does not and cannot guarantee the performance or results that may be obtained by using the Software: accordingly, the Software and Documentation are licensed as is: **NEITHER ABTEX NOR WESTMINSTER MAKES ANY WARRANTY, EITHER EXPRESS OR IMPLIED, AS TO ANY MATTER WHATSOEVER, INCLUDING WITHOUT LIMITATION, ANY WARRANTY OR MERCHANTABILITY OR FITNESS FOR A PARTICULAR PURPOSE.** The whole risk as to the results of the Software is assumed by the user.

LIMITATION OF LIABILITY Neither Abtex, nor Westminster, nor anyone else who has been involved in the preparation, production or distribution of the Software or Documentation shall be liable for direct, incidental or consequential damages including without limitation loss of actual or anticipated profits or benefits, resulting from the use of the Software.

TERM This license is effective until terminated. You may terminate it at any time by destroying all copies of the Software and Documentation in your possession, together with any modifications or merged portions thereof. The license will also terminate if the user fails to comply with any of the terms or conditions of this Agreement. The user agrees to destroy all copies, modifications and merged portions of the Software and Documentation of such termination.

NO OBLIGATION TO PROVIDE ENHANCEMENTS Abtex shall have no obligation hereunder to maintain or improve the Software or Documentation, or to provide you with, or notify you of, any such improvements if developed. However, Abtex may, in its sole discretion, make available to you enhanced versions of the Software and Documentation, which enhanced versions shall be included in the terms "Software" and "Documentation" as the case may be, and shall be subject to the terms and conditions hereof.

GOVERNING LAW This Agreement will be governed by the laws of the State of California.

COPYRIGHT NOTICE

SOFTWARE Copyright 1984 by Abtex Software Ltd., Great Britain. All rights are reserved. This document may not, in whole or in part, be copied, photocopied, reproduced, translated or reduced to any electronic medium or machine-readable form without prior consent in writing from:

Abtex Software Ltd.
11 Campus Road
Listerhills Science Park
Bradford BD7 1HR
Great Britain

DOCUMENTATION Copyright 1984 by Westminster Software Incorporated, California. All rights are reserved. This document may not, in whole or in part, be copied, photocopied, reproduced, translated or reduced to any electronic medium or machine-readable form without prior consent in writing from:

Westminster Software Incorporated
660 Hansen Way, Suite 2
Palo Alto, California 94304

ACKNOWLEDGEMENTS

MS-DOS is a trademark of Microsoft Corporation

PC DOS is a trademark of International Business Machines Corporation

Portions of the software program are copyrighted by Phoenix Computer Products Corporation; Lattice, Inc.; and MetaGraphics, Inc.

USER'S GUIDE

PERT PLOTTERTM

Westminster
oftware

| <i>Chapter</i> | <i>Title</i> | <i>Page</i> |
|----------------|---|-------------|
| 1 | INTRODUCTION TO PERTPLOTTER Introduction - Who Can Use PERTPLOTTER - Computer Hardware Requirements - Computer Software Requirements - Technical Support | 1-1 |
| 2 | HOW TO USE THIS MANUAL What to Read - Typefaces Used in this Manual | 2-1 |
| 3 | A REVIEW OF NETWORK ANALYSIS AND PERTMASTER What Is Network Analysis? - PERTMASTER's Network Analysis - Graphics Networks - PERTPLOTTER Formats - PERTPLOTTER and PERTMASTER | 3-1 |
| 4 | STARTING PERTPLOTTER Setting Up Your Computer - PERTPLOTTER's Disks - Configuring Your System for PERTPLOTTER - Special Keys - Configuring PERTPLOTTER to Your Computer | 4-1 |
| 5 | ANALYSIS AND OTHER REQUIREMENTS PERTPLOTTER/PERTMASTER Interaction - Analysis Requirements - Other System Requirements | 5-1 |
| 6 | CREATING A DRAWING SPECIFICATION FILE Starting Out - Help Menu - Creating a Drawing Specification | 6-1 |

- 7 MODIFYING A DRAWING SPECIFICATION FILE** 7-1
- Why Changes Are Made - Starting to Edit -
Selecting Activity Items - Selecting Links -
Milestone Descriptions - Selecting a Time
Window - Start and End Dates - Legend
Contents - Selecting Color - Selecting Line
Styles
- 8 PRODUCING A DRAWING** 8-1
- Saving Changes - Produce a Drawing
- 9 HOUSEKEEPING** 9-1
- PERTPLOTTER's Housekeeping Facilities -
Deleting Files - Scaling Factors -
Drawing Repair - Other Housekeeping
Facilities

INTRODUCTION

Welcome to PERTPLOTTER -- a printer/plotter driver program. PERTPLOTTER is designed to work in conjunction with PERTMASTER, a computerized network-analysis program. PERTPLOTTER extends the ability of PERTMASTER to create plotted or printed reports of network logic diagrams.

Although PERTPLOTTER is an independent, standalone program, it communicates very closely and shares files with PERTMASTER. The project plans that you generated with PERTMASTER form the data from which PERTPLOTTER produces its drawings. In short, you use PERTMASTER to create the logic network of project plans, and once they have been created, you use PERTPLOTTER to print or plot them.

WHO CAN USE PERTPLOTTER?

If you are in a decision-making position, regardless of level, you can benefit from PERTMASTER's network analysis. If you are using PERTMASTER to generate project plans, you can produce customized printed or plotted reports of your project plans with PERTPLOTTER.

Using PERTMASTER, you have had access to a powerful management planning tool. PERTPLOTTER enables you to expand on the work you have done with PERTMASTER in a very concrete way. Whether you choose "quick plot" drawings that show activity numbers, or fully annotated, multi-colored drawings of your entire network, PERTPLOTTER can provide you with the reports you need.

Like PERTMASTER, PERTPLOTTER is menu-driven -- that is, all instructions and choices appear on your computer screen -- no knowledge of programming is necessary. If you can press one key at a time on a keyboard, you can use PERTPLOTTER.

COMPUTER HARDWARE REQUIREMENTS

PERTPLOTTER requires the following computer hardware to operate:

1. A microcomputer using the MS-DOS or PC-DOS operating system with a minimum of 320K of random access memory (RAM).

2. Two disk drives. Although PERTPLOTTER could run on a single disk drive, it requires additional space to create the temporary files it needs in order to generate a drawing.
3. A video terminal. You may use a color terminal if you wish, but it is not required.
4. A pen plotter or a printer with graphics capability. Some of PERTPLOTTER's more advanced features, such as multi-color plotting, are currently available only if you use a plotter.

COMPUTER SOFTWARE REQUIREMENTS

PERTPLOTTER requires the following computer software to operate:

1. PERTMASTER network-analysis program. Although PERTPLOTTER is an independent program, it requires data, index, calendar, and parameter files contained within or generated by PERTMASTER. More information about these files and their contents will be found in Chapter 4 of this User's Guide and in Appendix B of the Reference Manual.
2. MS-DOS system configuration file. More information about this file, its contents, and how to create it will be found in Chapter 4 of this User's Guide.

TECHNICAL SUPPORT

Be sure to complete the PERTPLOTTER user license agreement and mail it to Westminster Software, Inc. After your completed license agreement has been received and registered, you have full technical support. You may contact the following Software Support Group for any assistance you require.

Westminster Software, Inc.
Software Support Group
660 Hansen Way, Suite 2
Palo Alto, California 94304
U.S.A.
Telephone: (415) 424-8300
Telex: 759818 WESTMINSTER MP

Please be prepared to give the serial number of your copy of PERTPLOTTER, since support is not provided to unregistered users.

WHAT TO READ

Like the PERTMASTER User's Guide, this PERTPLOTTER User's Guide has been written to satisfy two needs. First, we want you to be able to learn how to use PERTPLOTTER as quickly and easily as possible. Second, we want you to become proficient enough at using PERTPLOTTER so that you won't need this User's Guide.

By this we mean that using the tutorial approach of this User's Guide, you will quickly become adept at using PERTPLOTTER and will no longer need to be led through the procedures on a step-by-step basis. Instead, you will be able to use the Reference Manual to find answers that may arise in day-to-day use.

The PERTPLOTTER User's Guide consists of the following chapters, the first of which you have probably read already.

- Chapter 1 Introduction to PERTPLOTTER
- Chapter 2 How to Use this Manual
- Chapter 3 A Review of Network Analysis and PERTMASTER
- Chapter 4 Starting PERTPLOTTER
- Chapter 5 Analysis and Other Requirements
- Chapter 6 Creating a Drawing Specification File
- Chapter 7 Modifying a Drawing Specification File
- Chapter 8 Producing a Drawing
- Chapter 9 Housekeeping

Even if you are quite familiar with network analysis, we recommend that you scan Chapter 3, which provides a useful overview of the relationship between PERTPLOTTER and PERTMASTER.

When you are ready to start using PERTPLOTTER, Chapter 4 will provide you with the installation information you will need to make the program run on your computer. It also outlines the files shared by PERTPLOTTER and PERTMASTER, and specifies what information you will have to copy from your PERTMASTER disk onto your PERTPLOTTER disk.

Be sure to read Chapter 5. It explains in more depth the relationship between PERTPLOTTER and PERTMASTER, and describes the type of analysis you must perform with PERTMASTER before PERTPLOTTER can produce a drawing.

There are two modes in which PERTPLOTTER can operate. The first is the Drawing Specification MODE (DSM). When PERTPLOTTER is in this mode, you have the opportunity to specify which plan you wish to draw, the type of drawing you want, and various details pertaining to the style of lines and colors used. In Chapter 6, you will learn how to create a Drawing Specification File. In Chapter 7, you will learn how to modify an already existing Drawing Specification File.

PERTPLOTTER's second mode is the Drawing Production Mode (DPM). It is in this mode that PERTPLOTTER produces the drawing that you defined earlier. Instruction for producing a drawing are found in Chapter 8.

The final chapter of this User's Guide (Chapter 9) covers an assortment of PERTPLOTTER's functions that are referred to as "Housekeeping." These functions include deleting a drawing specification file, scaling factors, and drawing repairs. Housekeeping information is provided in greater detail in the Reference Manual that accompanies this User's Guide.

TYPEFACES USED IN THIS MANUAL

In an effort to maintain consistency between the PERTMASTER manual and this one, the same set of typefaces has been used in the PERTPLOTTER documentation as was used for PERTMASTER's manual. Again, we have tried to be consistent in using type that leaves no doubt in your mind as to what to do.

Instructions, commands, or other descriptive information that appears on your computer terminal is printed in **bold sanserif** type in this manual. Words that look **like this** in the manual are words that will appear on your terminal.

Words, numbers, or other data that you must type are printed in **bold italic**, with the two following exceptions.

- | | |
|---------------|---|
| RETURN | indicates the carriage-return key on your keyboard. It may be marked "RETURN," "CR," "ENTER," or designated with a right-angle arrow. |
| ESCAPE | indicates the escape key, which is normally marked either "ESC" or "ESCAPE." |

WHAT IS NETWORK ANALYSIS?

As a successful PERTMASTER user, you already have a very good idea of what network analysis is. It is a powerful management tool that enables you to break down a project into activities, decide how long each one will take, and determine how these activities relate to each other. If you would like to brush up on a bit of network analysis background, Chapter 3 of your PERTMASTER User's Guide will be most helpful.

PERTMASTER'S NETWORK ANALYSIS

Based on the information you give it about your project -- the activities, their durations, and the resources required to complete them -- PERTMASTER calculates the relationships within the project, identifies the critical activities and paths, and determines the resources you will need.

All of the information generated by PERTMASTER is available to you in a series of reports. Some of them can be viewed on the screen of your terminal, and all can be printed out on your printer. These reports are in the form of tables, barcharts, graphs, and histograms. PERTMASTER allows you to generate these reports immediately after you have entered the data.

PERTPLOTTER takes PERTMASTER's reporting capabilities one step further, allowing you to print or plot out the actual network that you have created in your project plan.

GRAPHICS NETWORKS

Back in the old days, before PERTMASTER that is, a project plan usually started with a drawing of a graphic network. Depending on the type of technique being used, this network drawing consisted of either boxes or arrows with the activities on them, some indication of the duration of the activities, and a graphic representation of the relationships between the activities.

Whole graphics departments were kept busy drafting and redrafting network plans. But there was a good reason for putting all of this material on a single drawing: the user could see at a glance much of the salient information needed to make decisions or plans.

Chapter 3 of the PERTMASTER User's Guide provides an excellent review of the two types of graphics networks: Activity-on-Arrow (or simply Arrow) and Activity-on-Node (also called Precedence).

PERTPLOTTER FORMATS

Just as PERTMASTER does, PERTPLOTTER has different formats for the two types of networks: Arrow and Precedence. The format that you will be able to draw with PERTPLOTTER depends on the analysis method you used with PERTMASTER. Throughout this manual, you will find references to the two methods and differing instructions addressed to the users of each method.

If you use the Arrow method, the drawing you produce will be composed of blocks that look something like this (allowing for the differences in drawing devices):

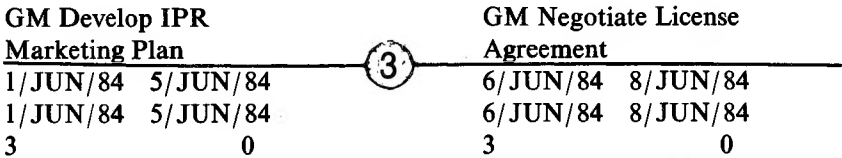

The section above the horizontal line is dedicated to the description of the activity. The first line below the horizontal line gives the early start and finish dates. The next line gives the late start and finish dates. The last line shows the duration (on the left) and the float (on the right).

If you use the Precedence method, the drawing you produce will be composed of blocks that look basically like this (again, allowing for the differences in drawing devices):

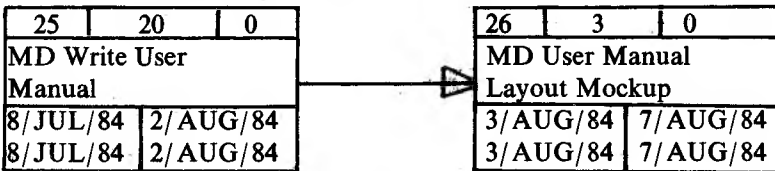

The top line of each box shows (from left to right) the node number, the duration of the activity, and the total float. The next two lines contain the activity description. The last two lines show the early start and finish dates and the late start and finish dates. The start dates and finish dates are in separate sections.

PERTPLOTTER AND PERTMASTER

PERTPLOTTER and **PERTMASTER** have more in common than just shared data files. Both programs take aspects of the tedious and sometimes difficult process of developing a network analysis project plan and turn them into much less time-consuming matters of entering the right kinds of data.

Just as **PERTMASTER** allows you to develop a project plan, **PERTPLOTTER** allows you to plot out the graphic network of the plan you have created. **PERTPLOTTER** has access to the data you input and the reports you generated with **PERTMASTER**. All you need to do to create a drawing of your network is tell **PERTPLOTTER** which project plan you wish to draw, what kind of printing or plotting device you want to use, and what you want the drawing to look like. **PERTPLOTTER** will do the rest.

SETTING UP YOUR COMPUTER

Having successfully used PERTMASTER, you are already aware of how your computer should be set up to operate properly. If you have not already set up your drawing device, be sure to follow all of the steps and tests outlined in your printer or plotter manual to ensure that your drawing device is interfaced correctly with your computer. Contact your technical advisor or the dealer from whom you bought your system if there is evidence of any problem. In starting PERTPLOTTER you will be asked a few questions about your drawing device, so it is a good idea to keep your printer or plotter manual handy.

CARE AND HANDLING OF DISKS

Like PERTMASTER, your PERTPLOTTER program is supplied on flexible magnetic disks, commonly called floppy disks. Although floppy disks are easily damaged, they will last almost indefinitely if given the proper care and handling. Even if you have many years of experience using computers, we strongly recommend that you take the time to reread the CARE AND HANDLING OF DISKS section of your select the last option . You will find it in Chapter 4, page 1-9.

PERTPLOTTER'S DISKS

Depending on the version you have, PERTPLOTTER is supplied to you on either one or two disks. If it is supplied on a single disk, everything you need will be on that disk. If it is supplied on two disks, disk 1 contains all necessary files to produce drawings for Activity-on-Arrow (Arrow) project plans. Disk 2 contains all necessary files to produce drawings for Activity-on-Node (Precedence) project plans.

Since only one copy of each disk is supplied, you must always make a back-up copy of each disk as a precautionary measure. The back-up copy will become your working copy of PERTPLOTTER and will be referred to as "working copy."

CONFIGURING YOUR SYSTEM FOR PERTPLOTTER

Because each computer system has different configuration requirements, it is impractical to include instructions in this manual for each of the many systems on which PERTPLOTTER will run. Therefore, we have prepared a separate sheet of configuration instructions for each of the computer systems that will run PERTPLOTTER. This instruction sheet was packaged with your PERTPLOTTER disk(s).

Follow the configuration instructions that came with your version of PERTPLOTTER. If you did not receive a configuration instruction sheet, or have misplaced the one you received, contact your dealer or the Software Support Group listed in Chapter 1. A set of replacement instructions will be supplied to registered PERTPLOTTER owners.

Please note that the configuration changes that you will be making will not take effect until after you reboot (restart) your system. Remember to do so before you attempt to use PERTPLOTTER. Once you have restarted your operating system, you are ready to configure PERTPLOTTER for your computer.

SPECIAL KEYS

PERTPLOTTER recognizes special meaning for three keys on your keyboard. In most cases, if you press the **ESCAPE** key once anywhere within PERTPLOTTER, you will automatically exit the option you are currently using and be returned to the previous menu. This is true if you have already selected an option from the menu that requires you to enter an answer.

If you have not selected an option from your menu, pressing **ESCAPE** will on the list, which is usually a return to the previous menu. If you press **ESCAPE** while you are producing a drawing, PERTPLOTTER will conclude the drawing session and return you to the Main Menu. You will be reminded of the special meanings of the **ESCAPE** key as they occur in the text of this manual.

Typing **?** at any point in PERTPLOTTER will provide any additional information that is available from PERTPLOTTER in the form of a "Help" screen. This is true even when you are entering data. Pressing **?** often is a good way of getting to know how PERTPLOTTER works.

Unless otherwise stated, one of two things will happen when you press the **RETURN** key once. PERTPLOTTER will assume that you either have chosen the currently displayed answer or have selected option 1 of the currently displayed menu.

CONFIGURING PERTPLOTTER TO YOUR COMPUTER

The first time you use PERTPLOTTER, follow the steps listed in the instruction sheet that accompanied your version of PERTPLOTTER. You may want assistance from your technical advisor or the dealer from whom you purchased PERTPLOTTER. Be sure to use the working copy of your PERTPLOTTER disk.

1. After you have completed the configuration steps explained in the instruction sheet that accompanied your version of PERTPLOTTER, you are ready to begin using the program. When the A prompt appears, type **PERTPLOT** and press **RETURN**.
2. After a few seconds, the following copyright notice should be displayed.

```
*****
*                *      PERTPLOTTER      *
*                *                        *
*                *                        *
*****
```

COPYRIGHT NOTICE

Version 1.03 / 500

Copyright 1984 by ABTEX Computer Systems Ltd, Aberdeen, Great Britain.

This software and related documentation contains proprietary information and valuable trade secrets of Abtex Computer Systems Ltd. Its receipt or possession does not contain any rights to produce or disclose its contents. Reproduction, disclosure or use without specific written authorization of Abtex Computer Systems Ltd. is strictly forbidden.

Your Personal Serial Number is 91324

NOTE: If either this screen or the one that follows is not perfectly formatted, please call one of the Software Support Groups listed in Chapter 1 for assistance. In most cases, an incorrectly formatted copyright screen or Main Menu is caused by the absence of the necessary configuration procedures. Recheck the CONFIGURING YOUR SYSTEM FOR PERTPLOTTER instruction sheet that accompanied your PERTPLOTTER program.

3. After a few seconds PERTPLOTTER's Main Menu will appear, and should look like the one that follows.

```
*****
* PLAN : MARKET v. 0      *      PERTPLOTTER      * DEV : HP 7475      *
* SPEC : DEFAULT          *                               * PAPER : 8.5 x 11 in *
*****
```

Do You Want To :-

- 1: Select Drawing Specification ?
- 2: Select Project Plan ?
- 3: Do Some Housekeeping ?
- 4: Examine Or Edit Current Drawing Specification ?
- 5: Save All Changes ?
- 6: Produce Drawing ?
- 7: End This Session ?

Please Press The Number Of Your Choice : []

Or Press ? For Additional Information.

PERTPLOTTER uses the box in the upper left of the screen to display the current project plan and drawing specification file names. In the block in the upper right, PERTPLOTTER displays the current drawing device and the current paper size. Initially, default values will be displayed.

* PLAN : MARKET v. 0 *
* SPEC : DEFAULT *

PERTPLOTTER

* DEV : HP 7475 *
* PAPER : 8.5 x 11 in *

Which Device Are You Going To Use :-

- 1: HP 7475
- 2: HP 7470
- 3: Six Shooter
- 4: Sweet-P
- 5: Epson MX-80 w/Graftrax
- 6: Epson MX-100 w/Graftrax
- 7: Epson FX-80
- 8: MORE SELECTIONS

Please Press The Number Of Your Choice : []

Or Press ? For Additional Information.

-
6. The drawing device list in this and the following menu section are intended as an example. Your Drawing Device Menu may contain more than two sections. This two-part menu lists the names of all drawing devices that PERTPLOTTER supports. If your drawing device is the first one listed, you may select it by pressing the **RETURN** key. To scan other names on the list, you may press the **DOWN ARROW** or type *N* to see the next page. You may also view the next page by typing *8* to select the **MORE SELECTIONS** option. The second page of the Drawing Device Menu will be displayed.

* PLAN : MARKET v. 0 *
* SPEC : DEFAULT *

PERTPLOTTER

* DEV : HP 7475 *
* PAPER : 8.5 x 11 in *

Which Device Are You Going To Use :-

- 1: Epson FX-100
- 2: IBM Graphics Printer
- 3: HP ThinkJet
- 4: HP LaserJet
- 5: NONE OF THESE

Please Press The Number Of Your Choice : []

Or Press ? For Additional Information.

Press the UP ARROW or type *P* to return to the previous page. Once you have located your drawing device on the list, type the number next to the name to select it. PERTPLOTTER will then know the correct way in which to communicate with your drawing device.

PERTPLOTTER will also know if your drawing device uses one size or more than one size of paper. If your drawing device uses more than one size of paper, PERTPLOTTER will automatically display a Paper Size Menu like the one that follows.

* PLAN : MARKET v. 0 *
* SPEC : DEFAULT *

PERTPLOTTER

* DEV : HP 7475 *
* PAPER : 8.5 x 11 in *

What Is The Size Of Your Paper :-

- 1: 8.5 x 11 in
- 2: 17 x 11 in
- 3: NONE OF THESE

Please Press The Number Of Your Choice : []

Or Press ? For Additional Information.

Select the correct paper size by typing the number next to it on the display. PERTPLOTTER will register your selection in the upper right box.

7. In addition to the size of your paper, PERTPLOTTER will automatically know what type of paper feed mechanism your drawing device can support. If your drawing device can only support one type of feed mechanism, like the Six-Shooter (single sheet only) or the Epson FX-10 (continuous form only), you need do nothing else and may proceed to step 10 below. If your drawing device is one that supports both types of paper feed, PERTPLOTTER will display a Paper Feed Menu similar to the one that follows.

* PLAN : MARKET v. 0 *
* SPEC : DEFAULT *

PERTPLOTTER

* DEV : HP 7475 *
* PAPER : 8.5 x 11 in *

Is Your Paper Feed Mechanism :-

- 1: Continuous Form ?
- 2: Single Sheet ?
- 3: NONE OF THESE

Please Press The Number Of Your Choice : []

Or Press ? For Additional Information.

PERTPLOTTER will then ask you to **Press The Number Of Your Choice**. Select the correct paper feed mechanism by typing the appropriate number. Check your drawing device manual if you are uncertain about the paper feed. For PERTPLOTTER's purposes, roll paper, fan fold, and drawing devices with mechanical paper feeders are all considered to be continuous form. PERTPLOTTER will register your selection and will automatically return you to the Housekeeping Menu.

- 8. You must now tell PERTPLOTTER the name of the port where your drawing device is connected to your computer. You may skip this step if you are using a printer as your drawing device. If you are using a serial plotting device, type **3** to select **Specify Device Attachment**. PERTPLOTTER will ask you to **Specify Your Device Attachment** and will highlight an area on the Housekeeping Menu screen where the name of your drawing device attachment port is to be displayed.

PERTPLOTTER now expects you to type the name of the port or slot on the side or the back of your computer to which your drawing device is connected. Under your MS-DOS operating system, the point of attachment is called a "logical device name." Check your drawing device manual and your MS-DOS manual to make sure that you have the correct name before typing it in. Typical MS-DOS logical device names are COM1, COM2, PRN, or LPT1. Once you are sure of the port name, type it in and press **RETURN**. PERTPLOTTER will display the port name on the right side of the screen.

Remember, if you are using a serial printer on an IBM-PC, a PC compatible, or on a standard MS-DOS machine, you will have to redirect LPT1 to the serial port with the **MODE** command. And example is:

MODE LPT1:=COM1:

9. The next piece of set up information PERTPLOTTER needs is the location of the data disk that contains your project plans and specification files. You indicate this by typing **4** to select the **Specify Data Drive** option.

PERTPLOTTER will ask you to **Specify Your Data Drive** and will highlight an area on the right side of the screen where the name of your data drive will be displayed. If your computer has two or more floppy-disk drives, type in the name of the drive into which you have inserted your data disk, and press **RETURN**. In most cases, this will be Drive B. If you are using a hard disk, type in the name of the drive where your project plans are located, and press **RETURN**.

10. This instruction applies if your drawing device is a printer or if you plan to draw Precedence project plans. In order for PERTPLOTTER to create a drawing, it must create a temporary file. The amount of free storage space required for the temporary file on the size and type of your project plans. A small Arrow plan might require as little as 6K. A large Precedence plan might require 128K. An average Precedence plan with 250 activities will require approximately 32K of free storage space. If you have a fast mass storage device, such as a RAM disk, this is the ideal location for the temporary file. Otherwise, the fastest mass storage device should be used. If you have a dual floppy disk system, we suggest that you use drive A. The PERTPLOTTER disk, as delivered, contains enough work space.

Select the location of your temporary file drive by typing **5** to **Specify Temporary File Drive**. PERTPLOTTER will ask you to **Specify Your Temporary File Drive** and will highlight an area on the right side of the screen where the name of your temporary file drive will be displayed. Type the name of the drive (in most cases **A**) and press **RETURN**.

11. You have now completed the initial housekeeping required to configure PERTPLOTTER to your computer. From the Housekeeping Menu, type **6** to **Return to Main Menu**.
12. The changes that you made using the Housekeeping Menu are an essential part of the PERTPLOTTER start-up procedure. You will, therefore, want to save the changes that you made. You may do so by typing **5** to **Save All Changes**.

PERTPLOTTER will then ask you to **Enter The Name Of Your Drawing Specification** and will display a highlighted area on the right of the screen where the name of your specification will be displayed. The initial start-up name will be **DEFAULT**. You can, if you wish, rename this file, but for the time being, let's keep **DEFAULT** as the file name. Press **RETURN** and the file will continue to be named **DEFAULT**. (If you wish, you can give this file another name. Do so by typing in a file name with up to eight characters. Press **RETURN**.)

PERTPLOTTER will inform you that it is **Saving Changes** and will then display your drawing specification file name in the upper left display box. This file, with all of the entries you made from the Housekeeping Menu, will become your current default file. The next time you use PERTPLOTTER, this file will be your current specification.

13. You are now ready to end your first PERTPLOTTER session. Type **7** to **End This Session**. PERTPLOTTER is now configured to your computer and is ready to produce drawing specifications. Before you do so, however, we suggest that you make one final check in your PERTMASTER project plans. Chapter 5 explains this next step.

PERTPLOTTER/PERTMASTER INTERACTION

As we have mentioned before, PERTPLOTTER extends PERTMASTER's reporting capabilities by allowing you to print or plot the network logic diagrams that PERTMASTER creates based on your project plan. By now, you have configured PERTPLOTTER to run on your computer. You have also given PERTPLOTTER access to certain PERTMASTER files as well as the project plan files that you have created.

It is the sharing of these files that forms the basis of the interaction between PERTPLOTTER and PERTMASTER.

ANALYSIS REQUIREMENTS

Before PERTPLOTTER can produce a drawing of your project plan, it must have a Time Analysis Disk Report from which it obtains information about the timing of activities in your project. Refer to Sections 4.6 and 4.6.1 of your PERTMASTER Reference Manual for information on how to generate a Time Analysis Disk Report. You may choose to sort your Time Analysis Disk Report using any of the options available.

PERTPLOTTER can obtain the information it needs regardless of the format.

OTHER SYSTEM REQUIREMENTS

There is one final requirement that PERTPLOTTER has of PERTMASTER. In order to produce a drawing, PERTPLOTTER must have access to the node/activity numbers in your project plan. To provide this information, you must select to show node/activity numbers in your PERTMASTER reports. Section 5.4 of your PERTMASTER Reference Manual gives instructions for how to select this option.

You are now ready to create a drawing specification file. Turn to Chapter 6 for directions on how to do so.

STARTING OUT

The drawing specification file is really the heart of the matter as far as PERTPLOTTER is concerned. PERTPLOTTER must have a drawing specification file in order to produce a drawing. This file contains your instructions as to what you want your drawing to contain and how you want it to look.

PERTPLOTTER must also have access to a valid PERTMASTER project plan, since this forms the content of the drawing. Please make sure that you have completed the steps outlined in Chapter 5 for analysis and other system requirements.

Your PERTPLOTTER disk will come with a drawing specification file already installed in the form of a default file. This file contains settings for many of the drawing characteristics that will be discussed later in this chapter. The default file gives you a starting point from which you can create as many drawing specifications as you choose.

The process for creating a drawing specification file is quite simple. The first step is to call up an already existing specification. For first-time users, this specification will be the default file. This file will automatically be there when you start PERTPLOTTER for the first time. (If you entered a name other than DEFAULT during start-up procedures, that file will be the current file when you restart PERTPLOTTER.)

The second step is to select a project plan that you wish to draw. The third step is to use the Edit Menu to make changes to the default file to reflect your preferences for drawing content and characteristics. And the last step is to save the changes you have made and give them a file name. You will then have created your first drawing specification.

Step-by-step instructions for creating and modifying a drawing specification file are contained in the rest of this chapter.

HELP MENU

Before we look at how to create a drawing specification, let's briefly examine PERTPLOTTER's Help Menu. You can gain access to additional information and instructions from each of PERTPLOTTER's menus and screens. Do this by typing ? (question mark). A highlighted message area will appear at the bottom of the screen.

Some Help messages are in the form of instructions or further definitions of the kind of response PERTPLOTTER needs from you. Other Help messages give an explanation of why PERTPLOTTER needs the information it has requested from you. You can reach a Help message at almost any point in PERTPLOTTER by typing ?. Typing ? often is a good way to learn about PERTPLOTTER and how it works.

CREATING A DRAWING SPECIFICATION

Although you did not select any drawing characteristics at the time, you actually created your first drawing specification file when you completed the start-up procedures outlined in Chapter 4. That file is the one that PERTPLOTTER will consider to be its current specification when you restart the program for your first editing session.

Insert your system disk in the primary disk drive and call up your operating system. When the A prompt appears, remove the system disk and insert the PERTPLOTTER disk in the primary drive and the PERTMASTER data disk in the drive that you designated during PERTPLOTTER start-up. If you are using a hard-disk drive, go to the directory where PERTPLOTTER is located. Type **PERTPLOT** to call up the PERTPLOTTER program.

First the copyright notice will appear, followed by the Main Menu. The Main Menu screen will be similar to the one that follows.

* PLAN : MARKET v. 0 *
* SPEC : DEFAULT *

PERTPLOTTER

* DEV : HP 7475 *
* PAPER : 8.5 x 11 in *

Do You Want To :-

- 1: Select Drawing Specification ?
- 2: Select Project Plan ?
- 3: Do Some Housekeeping ?
- 4: Examine Or Edit Current Drawing Specification ?
- 5: Save All Changes ?
- 6: Produce Drawing ?
- 7: End This Session ?

Please Press The Number Of Your Choice : []

Or Press ? For Additional Information.

Remember that you can type ? at any time for additional information. The information message on the Main Menu tells you how to select the various options. It also informs you that you may explore any of the options without causing any damage. The name of your current drawing specification will be displayed in the box on the upper left of the screen. There is also space for the name of a project plan. Your first task, then, is to select the project plan that you would like to draw.

PERTPLOTTER will ask you to **Select Project Plan**. A Project Plan Menu similar to the one that follows will appear. It will contain a list of possible project plans that PERTPLOTTER got from your PERTMASTER index. Your project plans should all be listed, but don't be dismayed if all of them are not.

* PLAN : MARKET v. 0 *
* SPEC : DEFAULT *

PERTPLOTTER

* DEV : HP 7475 *
* PAPER : 8.5 x 11 in *

Which Project Plan Would You Like To Use :-

- 1: MARKET v. 0
- 2: PRODUCT v. 0
- 3: HOUSE v. 0
- 4: NONE OF THESE

Please Press The Number Of Your Choice : []

Or Press ? For Additional Information.

Scan the list displayed on the Project Plan Menu. Is the project plan you want to draw listed? If so, you can select that project plan by typing the number next to it. PERTPLOTTER will display the project plan you have chosen in the box on the upper left and will automatically return you to the Main Menu. You can, if you wish, work with MARKET as your current project plan.

In the list above, for example, you could select **HOUSE** by typing **3**. If you have generated more project plans than will fit on one screen, you can view the next portion of the list either by typing *N* (for next) or pressing the DOWN ARROW. PERTPLOTTER will display additional project plan names. Again, if your project plan is listed, type the number next to it.

You can return to the first part of the list by pressing the UP ARROW or typing **P** (for previous). As always, if you press **RETURN**, you will select the will select the last option on the list before it automatically returns you list. Pressing **ESCAPE** to the (previous) Main Menu.

If your list is a long one, you can save yourself the time it would take to scroll through it by electing to enter the name of your project plan manually. You can do this by typing **M**. PERTPLOTTER will then ask you to **Enter The Name Of Your Plan** and will highlight an area on the right of the screen where your project plan name is to be displayed. You can only use the manual loading option if you know the exact eight-character name of the project plan you wish to use.

If you plan to enter the name manually, do so now by typing the eight-character name of your project plan. Then press **RETURN**. PERTPLOTTER will then ask you to **Enter The Version Number** of the project plan you have selected. You can do this by typing the number and pressing **RETURN**. PERTPLOTTER will search its directory of available project plans for the name you have typed. If the name is in the directory, PERTPLOTTER will load the plan.

If the name you have chosen is not in the directory, an error message will appear instructing you to select another plan. For the time being, select a project plan and either type the number next to it or type in the name and version number. PERTPLOTTER will return you to the Main Menu. With this task done, you are ready to edit your first drawing specification file. Chapter 7 explains how to do this.

WHY CHANGES ARE MADE

In Chapter 6 you learned how to select a project plan and create a drawing specification file. But the file that you created contained little else besides configuration information. You have yet to actually decide what you want to include in your drawing and how you want it to look.

Just as you used PERTMASTER to create more than one project plan, so too will you use PERTPLOTTER to create more than one specification file. You may, for example, want to draw the same project plan many different ways, eliminating activities as they are completed, or adding additional information. You may wish to make a presentation for which a multi-color drawing with four different line styles is the most appropriate. For a fast update, on the other hand, you might wish to have a single-color, single-line style sketch without milestone descriptions or legend box. The possibilities are endless, and you will need to edit an already-existing drawing specification file to create each one. With all that in mind, let's look at how to edit a drawing specification.

STARTING TO EDIT

At the end of the last chapter, you were back at the Main Menu. You can begin the editing process by typing **4** to **Examine Or Edit Current Drawing Specification**. The Edit Menu, similar to the one that follows, will appear.

* PLAN : MARKET v. 0 *
* SPEC : DEFAULT *

PERTPLOTTER

* DEV : HP 7475 *
* PAPER : 8.5 x 11 in *

Which Of The Following Items Do You Wish To Edit ?

- 1: Activities.
- 2: Links.
- 3: Milestones.
- 4: Time Window.
- 5: Legend.
- 6: Color.
- 7: Line Style.
- 8: Return To Main Menu.

Please Press The Number Of Your Choice : []

Or Press ? For Additional Information.

SELECTING ACTIVITY ITEMS

The first decision you must make concerns activities, so type **1** to select **Activities**. An Activities Menu similar to the one that follows will appear. Current default values will be displayed at the right side of the screen.

* PLAN : MARKET v. 0 *
* SPEC : DEFAULT *

PERTPLOTTER

* DEV : HP 7475 *
* PAPER : 8.5 x 11 in *

Which Of The Activity Items Should Be Included In Your Drawing ?

- | | | |
|----|--------------------------|-----|
| 1: | Duration. | Yes |
| 2: | Total Float. | Yes |
| 3: | Description. | Yes |
| 4: | Early Start And Finish. | Yes |
| 5: | Late Start And Finish. | Yes |
| 6: | Return To Main Menu. | |
| 7: | Return To Previous Menu. | |

Please Press The Number Of Your Choice : []

Or Press ? For Additional Information.

This screen lists the various types of activity items you can include in your drawing. Examine this screen carefully, one item at a time.

1. Duration

The duration is the amount of time it takes to complete an activity. Is the current duration default value on the right side of the screen the correct one? If the default value is the answer you want, you need do nothing. If you want to change the current duration default value, all you have to do is type *1*. If you type *1* twice in a row, you will change the default value to the opposite value, and then change it back again. For now, set duration to **Yes**.

2. **Total Float**

Float indicates the amount of time an activity can be delayed without affecting the outcome of the project. Is the current total float default value on the right side of the screen the correct one? If the default value is the answer you want, you need do nothing. If you want to change the current float default value, all you have to do is type **2**. For now, set float to **Yes**.

3. **Description**

If you choose to include **Description**, the text that you entered for each activity in your PERTMASTER project plan will be shown on your drawing. Is the current description default value on the right side of the screen the correct one? If the default value is the answer you want, you need do nothing. If you want to change the current description default value, all you have to do is type **3**. For now, set description to **Yes**.

4. **Early Start And Finish**

Early start and finish refers to the earliest possible start and finish information you entered in PERTMASTER while creating your project plan. Is the current early start and finish default value on the right side of the screen the correct one? If the default value is the answer you want, you need do nothing. If you want to change the current early start and finish default value, all you have to do is type **4**. For now, set early start and finish to **Yes**.

5. **Late Start And Finish**

Late start and finish refers to the latest possible start and finish information you entered in PERTMASTER while creating your project plan. Is the current late start and finish default value on the right side of the screen the correct one? If the default value is the answer you want, you need do nothing. If you want to change the current late start and finish default value, all you have to do is type **5**. For now, set late start and finish to **Yes**.

Examine the Activities Menu screen again. Are all the values set the way you want them (to Yes)? If so, you are ready to exit from this option. You may come back to this option later if you wish.

There are two ways that you can exit from this option. Typing **6** returns you to the Main Menu. Typing **7** returns you to the Edit Menu. At this point, type **7** to **Return To Previous Menu** and continue editing your drawing specification.

SELECTING LINKS

This section applies mostly to users of the Precedence method of network analysis. If you used PERTMASTER's Arrow method, skip the first three options in this section and go directly to option 4. If you used PERTMASTER's Precedence method, the first part of this section will be of interest to you. It deals with the way in which the links between the activity items on your drawing will be labeled. From the Edit Menu, type **2** to select **Links**. A Links Menu like the one that follows will appear. Remember, you can get more information about the Links Menu by typing **?** as soon as the menu appears.

```

*****
* PLAN : MARKET v. 0      *      PERTPLOTTER      * DEV : HP 7475      *
* SPEC : DEFAULT         *                               * PAPER : 8.5 x 11 in *
*****

```

Which Of The Link Items Should Be Included In Your Drawing ?

- | | | |
|----|--|-----|
| 1: | Start-Start Label And Duration. | Yes |
| 2: | Finish-Start Label And Duration. | Yes |
| 3: | Finish-Finish Label And Duration. | Yes |
| 4: | Do You Wish To Draw Links To and From Activities Omitted From The Plot. | Yes |
| 5: | Return To Main Menu. | |
| 6: | Return To Previous Menu. | |

Please Press The Number Of Your Choice : []

Or Press ? For Additional Information.

The current default values are displayed on the right side of your screen. The way in which you set the link label values depends on the type of links you used in your PERTMASTER project plan. You can change any of the default values by typing the number that is next to the link label item you wish to change.

1. Start-Start Label And Duration

The Start-Start link runs from the beginning of one activity to the beginning of the next. Is the current label value set the way you want it? If so, you need do nothing. If you want to change the current Start-Start link setting, type **1** to change the setting of the **Start-Start Label And Duration** specification.

2. Finish-Start Label And Duration

The Finish-Start link runs from the end of one activity to the beginning of the next. Is the current label value set the way you want it? If so you need do nothing. If you want to change the current Finish-Start link setting, type **2** to change the setting of the **Finish-Start Label And Duration** specification.

3. Finish-Finish Label And Duration

The Finish-Finish link runs from the end of one activity to the end of the next activity. Is the current label value set the way you want it? If so, you need do nothing. If you want to change the current Finish-Finish link setting, type **3** to change the setting of the **Finish-Finish Label And Duration** specification.

This section applies to both Arrow plans and Precedence plans. After you have considered the types of link labels you wish to show, you must then decide whether or not you wish to draw and label links to activity items that will not be part of your drawing. This option will be of interest to you if you do not intend to show your entire project plan in this drawing. If, for example, you plan to show only the middle third of your project, there will be activity items that will be omitted. You can indicate that there are unshown activity items by setting option **4: Do You Wish To Draw Links To And From Activities Omitted From The Plot?** to **Yes**.

Examine this option on your Links Menu. Is it set to the value you want? If so, you need do nothing. If you want to change the value of the current off-drawing links, type **4** and the value will be changed.

Take another look at the Links Menu screen. Are all the values set the way you want them? If so, you are ready to exit from this option. You may come back to this option later if you wish. There are two ways that you can exit from this option. Typing **5** returns you to the Main Menu. Typing **6** returns you to the Edit Menu. At this point, type **6** to **Return To Previous Menu** and continue editing your drawing specification.

MILESTONE DESCRIPTIONS

Users of both PERTMASTER network analysis methods had the opportunity to enter milestone descriptions as they created their project plans. In this option, you can choose whether or not you want to include those milestone descriptions in your drawing. Type **3** from the Edit Menu to select the **Milestone Descriptions** option. A Milestone Description Menu, similar to the one shown below, will be displayed.

```
*****
* PLAN : MARKET v. 0      *      PERTPLOTTER      * DEV : HP 7475      *
* SPEC : DEFAULT          *                               * PAPER : 8.5 x 11 in *
*****
```

Do You Wish To Draw The Milestones With Descriptions ? Yes

Please Press The Number Of Your Choice : []

Or Press ? For Additional Information.

The current setting of the Milestone option is shown on the right of the screen. For this particular option, PERTPLOTTER accepts answers in the form of Y for Yes or N for No. If you wish to include milestone descriptions in your drawing, type Y. Type N if you do not wish to include milestone descriptions in your drawing. You will automatically be returned to the Edit Menu after you make your selection.

SELECTING A TIME WINDOW

After you select your milestone description setting, PERTPLOTTER will automatically return you to the Edit Menu and ask you to **Press The Number Of Your Choice**. Type 4 to select **Time Window**. This will give you the opportunity to determine how much of your project plan will be included in your drawing. A Time Window Menu similar to the one below will be displayed. Remember to press ? to access the additional information display at the bottom of the screen.

```
*****
* PLAN : MARKET v. 0      *      PERTPLOTTER      * DEV : HP 7475      *
* SPEC : DEFAULT          *                               * PAPER : 8.5 x 11 in
*****
```

Please Define A Time Window :-

- 1: Start Date : START
- 2: End Date : FINISH
- 3: Entire Project.
- 4: Return To Main Menu.
- 5: Return To Previous Menu.

Please Press The Number Of Your Choice : []

Or Press ? For Additional Information.

A time window is defined by a set of start and end dates. The current default values will be displayed on the right of the screen. You can establish your time window in one of two ways: by entering a start date and an end date, or by specifying that you want to include the entire project. Let's look at setting start and end dates first.

START AND END DATES

Type *I* to set your **Start Date**. As soon as you do so, PERTPLOTTER will highlight an area on the right of the screen where the current start date default value is located and where your new start date will be displayed. PERTPLOTTER will ask you to **Enter Start Date Of Time Window**. There are three ways to enter a start date. Try each of them to get the feel for the possible options you have.

The first way to enter a start date is by typing in a specific date on which you wish your drawing to start. The correct format is **DD/MMM/YY**. Then press **RETURN**. An example would be **13/JUN/76**.

If your date is within the time frame of your project plan, PERTPLOTTER will register it in the display area on the right of the screen. If your date is before the beginning of your project plan, PERTPLOTTER will display the date you enter and assume that you want to use the beginning of the project as your start date. If your date is after the end of the project plan, an error message will inform you of that fact and will request that you enter an accurate date.

PERTPLOTTER will then ask you to **Press The Number Of Your Choice**. Type *I* again to try another method of entering a **Start Date**.

The next way to set your start date is by typing in a number that represents a number of working days after the beginning of the project. Then press **RETURN**. An example would be **5**. If you enter 5 and press **RETURN**, your drawing will start on the fifth working day of your project plan. PERTPLOTTER will automatically translate the number of working days you have entered into a date according to your project plan calendar. It will then display that date on the right side of the screen.

If you enter a number of working days that is greater than the duration of your project, PERTPLOTTER will inform you of that fact and will ask you to modify your start date. PERTPLOTTER will then ask you to **Press The Number Of Your Choice**. Type *I* again to try another method of entering a **Start Date**.

The final way to enter a starting date for your drawing is by typing either **START** or **S**. Then press **RETURN**. PERTPLOTTER accepts both the word and the letter as valid starting dates. Regardless of which one (**S** or **Start**) you enter, PERTPLOTTER will automatically display **START** as the start date. **START** means the start date of the project plan.

PERTPLOTTER will then ask you to **Press The Number Of Your Choice**. Type **2** to set **End Date**.

When you select option **2: End Date**, PERTPLOTTER will highlight an area on the right of the screen where your end date will be displayed.

PERTPLOTTER will ask you to **Enter Finish Date of Time Window**. As with the start date, you can enter the date in one of the three ways described below.

The first method is by typing a specific date on which you want your drawing to end. The correct format is **DD/MMM/YY**. An example would be **10/MAR/84**. Press **RETURN** after you have typed the date. The same rule for valid dates applies. Your end date has to be within the parameters you established in your project plan.

If the date you have selected is valid, PERTPLOTTER will register it on the right of the screen. If your date is after the end of your project plan, PERTPLOTTER will display the date and assume that you want to use the end of the project as your finish date. If your date is before the beginning of the project plan, an error message will inform you of that fact and will request that you enter an accurate date.

PERTPLOTTER will then ask you to **Press The Number Of Your Choice**. Type **2** again to try the second method of entering an end date.

PERTPLOTTER will accept a number of working days after the start of your project plan as a valid end date of your drawing. The only requirement is that the end day you enter must be after your start date and before the end of the project. Simply type in the number of working days after the start of the project that you want to use as an end date and press **RETURN**. PERTPLOTTER will automatically translate those days into a date and will display that date on the right of the screen.

An example would be **60**. This would end your drawing on the sixtieth working day of your plan.

PERTPLOTTER will now ask you to **Press The Number Of Your Choice**. Type **2** once more to try the last way to enter an end date.

As with setting the start date, PERTPLOTTER also recognizes the word **FINISH** and the letter **F** as valid ending dates. You can type either **FINISH** or **F**, then press **RETURN**. PERTPLOTTER will display **FINISH** as the end date on the right of screen and will ask you to **Press The Number Of Your Choice**. **FINISH** means the end date of the project plan.

You can explore the second way to establish a time window by typing **3** to select the **Entire Project**. When you do so, PERTPLOTTER will immediately set the start date to **START** and the end date to **FINISH**.

For the purposes of this first specification file, leave your time window set to include your entire project plan. Double check to make sure that the beginning and end dates of your time window are set to **START** and **FINISH**. Once they are correctly set, type **5** to **Return To Previous Menu**. This will return you to the Edit Menu.

LEGEND CONTENTS

The legend box appears in the lower left corner of your drawing. It contains a good deal of information that you entered into your project plan while using PERTMASTER. Included are such items as Right, Left, and Center Report Titles, date of drawing, and an explanation of any color and line style variations you might be using. It takes a few extra minutes to draw the legend box, but in most instances, this is time well spent. The one exception would be when you want to create a "fast plot" drawing that contains activity items only.

After choosing your time window, you were returned to the Edit Menu. From there, type **5** to reach the Legend Menu. A screen similar to the one that follows will appear. Remember, you can get access to additional information if you type **?** before making a selection from the Legend Menu.

* PLAN : MARKET v. 0 *
* SPEC : DEFAULT *

PERTPLOTTER

* DEV : HP 7475 *
* PAPER : 8.5 x 11 in *

Which Items Should Be Included In Your Legend ?

- | | | |
|----|--------------------------|-----|
| 1: | Show Legend. | Yes |
| 2: | Left Title. | Yes |
| 3: | Center Title. | Yes |
| 4: | Right Title. | Yes |
| 5: | Drawing Date. | Yes |
| 6: | Additional Descriptions. | |
| 7: | Return To Main Menu. | |
| 8: | Return To Previous Menu. | |

Please Press The Number Of Your Choice : []

Or Press ? For Additional Information.

The first thing you must decide is whether or not you want to include a legend box in your drawing. Since you must include the legend in order to use the other parts of this menu, the answer for this session will be Yes. The current default values are displayed on the right side of the screen. Is **Show Legend** set to **Yes**? If it is, you need do nothing else. If it is set to **No**, you can change the setting by typing **1**. This will automatically change the answer displayed to the opposite. If you type **1** again, the setting will revert to what it was originally. Set Show Legend to Yes.

The next three items on the Legend Menu refer to the titles that you entered into your PERTMASTER project plan. They are **Left Title**, **Center Title**, and **Right Title**. For now, let's include all of them in your legend box. This means that you will want a setting of **Yes** for each of the titles.

Is the current setting for **Left Title** correct? If so, move on to **Center Title**. If not, type **2** to change the left title setting to **Yes**. The same is true of **Center Title** and **Right Title**. Examine each one to make sure that they are set to **Yes**. If they are not, type **3** to change the setting for **Center Title** and **4** to change the setting for **Right Title**.

The next item that you can include in your legend box is the date of the drawing. It's a good idea to use this feature, particularly if you are making many revisions of your project plan or your drawing. The drawing date provides a reference point to enable you to distinguish among what may be many similar drawings. Look at the setting of **Drawing Date**. Is it set to **Yes**? If so, you can move on to the next option. If not, type **5** as many times as it takes to wind up with a **Yes** setting.

Additional Descriptions, option number **6** on the Legend Menu refers to a space for up to four lines of text that is allotted in the lower left of the legend box. Each line can contain up to 30 characters. You can include anything you want from a description of the project plan to rhyming couplets. It's up to you.

You can include additional description lines by typing **6**. An **Additional Descriptions** Menu similar to the one that follows will appear.

* PLAN : MARKET v. 0 *
* SPEC : DEFAULT *

PERTPLOTTER

* DEV : HP 7475 *
* PAPER : 8.5 x 11 in *

Please Define Your Additional Legend Lines:

- 1: Line 1: For, lo, the winter is past,
- 2: Line 2: The rain is over and gone; The
- 3: Line 3: flowers appear on the earth;
- 4: Line 4: The time of singing is come...
- 5: Clear Line
- 6: Return To Main Menu
- 7: Return To Previous Menu

Please Press The Number Of Your Choice : []

Or Press ? For Additional Information.

The process for adding each line of text is very simple. To add the first line, for example, type *1*. PERTPLOTTER will highlight an area on the right of the screen where your line text will appear, and will ask you to **Enter Content Of This Line**. Type in the text that you want to show on the first line and press return. You may backspace or use cursor control arrows to correct errors before pressing **RETURN**. PERTPLOTTER will remove the highlight and will ask you to **Press The Number Of Your Choice**.

Type *2* to enter your second line of text, type in the text, and press **RETURN**. Keep going until you have entered all of your text.

You also have the capability of removing the lines of text one at a time. This is accomplished by typing **5** to **Clear Line**. PERTPLOTTER will ask you to **Enter Line Number To Clear**. Type in the number of the line you want to delete and it will be immediately cleared.

There may come a time when you decide that Biblical verse is not quite appropriate for a new management plan, and you may want to remove the lines of additional text you have entered. You can do this by pressing **RETURN** to erase all of the lines of text.

Try adding some lines of descriptive text. When you are satisfied with your efforts, type **7** to return to the Legend Menu. This completes the editing of the legend box, so type **8** to return to the Edit Menu.

SELECTING COLOR

The amount of color that you can include in your drawing depends on the type of drawing device you have. If you are using a single-ribbon printer, you are restricted to to that one color and may skip this section and go on to the one that deals with line style. If you are using a plotter with multi-pen capabilities, you can use additional colors to identify the different types of line and activity items in your drawing.

At the end of the Legend Menu you returned to the Edit Menu. Now type **6** to add **Color** to your drawing. PERTPLOTTER will display a Color Menu similar to the one that follows and will ask you **What Color Would You Prefer To Use**.

* PLAN : MARKET v. 0 *
* SPEC : DEFAULT *

PERTPLOTTER

* DEV : HP 7475 *
* PAPER : 8.5 x 11 in *

What Color Would You Prefer To Use As

- | | | |
|----|-------------------------|---|
| 1: | Milestone Color | 1 |
| 2: | Completed Color | 1 |
| 3: | Critical Path Color | 1 |
| 4: | Dummy Color | 1 |
| 5: | Return To Main Menu | |
| 6: | Return To Previous Menu | |

Please Press The Number Of Your Choice : []

Or Press ? For Additional Information.

The numbers on the right of the screen refer to the pen numbers of your plotter. In this instance, all of the possible items are set to the same color, pen number 1, which is usually black. Refer back to your plotter manual if you have any questions about how many pens you have at your disposal and how they are arranged.

There are four possible areas that you can elect to show in different colors. They appear on the left of the screen. All other lines in your drawing will be made in the color of the default pen, which is pen number 1. Examine the setting for each color and decide which color you want each area to be. You select color by first choosing an area and then setting a pen color. You can select areas in any order, but let's begin with **1: Milestone Color**. Type **1** to initiate the setting.

PERTPLOTTER will ask you to **Enter The Pen Number Of Your Chosen Color**, and will highlight an area on the left of the screen. Type the number of the pen that you want to use for the milestones in your drawing. PERTPLOTTER will register your request and will ask for another selection. You can change as many of the colors as you want in this manner. When you are satisfied that all of the areas are the color you want them, type **6** to return to the Edit Menu.

PERTPLOTTER will permit you to specify more colors than you have holders on your drawing device. This allows users of plotters with only two pen holders to drawing project plans using more than two colors. PERTPLOTTER does this by rotating the required pens through the available penholders. It will assume that you have pen 1 in penholder 1 and pen 2 in penholder 2. If it becomes necessary for you to change pens, PERTPLOTTER will alert you that a change needs to be made, and will tell which pen to place in which penholder. More information about changing pens can be found in Chapter 8.

SELECTING LINE STYLE

Regardless of the type of drawing device you used, you can vary the types of lines that designate the various areas in your drawing. From the Edit Menu (where you wound up after choosing color), type **7** to select **Line Style**. A Line Style Menu similar to the one that follows will appear.

* PLAN : MARKET v. 0 *
* SPEC : DEFAULT *

PERTPLOTTER

* DEV : HP 7475 *
* PAPER : 8.5 x 11 in *

What Line Style Would You Prefer To Use As

- | | | |
|----|-------------------------|---|
| 1: | Milestone Line | 1 |
| 2: | Completed Line | 2 |
| 3: | Critical Path Line | 3 |
| 4: | Dummy Line | 4 |
| 5: | Return To Main Menu | |
| 6: | Return To Previous Menu | |

Please Press The Number Of Your Choice : []

Or Press ? For Additional Information.

The items on the left of the screen are the same ones that you already selected colors for (if you didn't select color, not to worry). The numbers on the right represent line styles. The line style - number correlation is as follows:

- | | |
|-------------------|-----------------|
| 1 = solid | _____ |
| 2 = dashed | ----- |
| 3 = dotted | |
| 4 = dashed-dotted | - . - . - . - . |

You can display these numbers and line styles at the bottom of your screen by typing ?. Do so now. If you were to choose the values displayed, milestones would be drawn in a solid line, completed items in a dashed line, the critical path in a dotted line, and dummy lines in a dashed-dotted line.

How you set the line styles is entirely up to you. You can select them in any order, but for the sake of simplicity, let's start with **Milestone Line** by typing **1**. PERTPLOTTER will highlight an area on the right of the screen where the numbers are displayed and will ask you to **Choose The Options Between 1 And 4**. Refer to the Help Message at the bottom of your screen for line style index numbers.

Let's say that you want milestones to be draw with a dashed-dotted line. You would then type **4** to change the value of **Milestone Line**. Your new choice will be displayed and you will be asked to make another selection. All of the line styles can be selected this way.

Examine all of the possibilities and decide what types of lines you wish to use for the various areas on your drawing. Then use the method described above to set the value correctly for each of the possibilities listed. When you are satisfied that the lines are set correctly, type **6** to return to the Edit Menu. Are there any of the options listed on the Edit Menu that you would like to return to? If so, do it now. If you are satisfied that you have described the drawing that you want to produce, type **8** to **Return to Main Menu**. You are now ready to save the changes you have made and produce a drawing. Chapter 8 explains how to do this.

SAVING CHANGES

Now that you have finished editing your drawing specification file, it would be a shame to lose all of the good work that you've just done. You have already saved the changes you made when you first set up your PERTPLOTTER program, so this section is intended only as a refresher before you produce a drawing.

At the end of your editing session, you returned to the Main Menu. You will now want to type **5** to **Save All Changes**. PERTPLOTTER will then ask you to **Enter The Name Of Your Drawing Specification** and will highlight an area on the right of the screen where your current specification file name will be displayed.

Decide on a new file name, and type it in. For the purposes of this first time through PERTPLOTTER, let's use the file name FRSTSPEC. Type **FRSTSPEC**. Then press **RETURN**. PERTPLOTTER will inform you that it is **Saving Changes** and will display your new file name FRSTSPEC in the box in the upper left. FRSTSPEC will become your current specification file. If you were to end this PERTPLOTTER session right now, the new file that you have just created would be the current specification file the next time that you call up the PERTPLOTTER program.

If, by chance, you forget to save your changes, PERTPLOTTER will query you about saving changes before it will allow you to produce a drawing or end a session.

PRODUCE A DRAWING

Now comes the moment you have been waiting for, the chance to produce a drawing from your specifications. Type **6** to **Produce Drawing**. As it prepares to make the drawing, PERTPLOTTER will display a number of pieces of information on the Drawing Production Mode (DPM) screen. If you use the Arrow method, it will be similar to the one that follows.

Please Wait...
Reading file a:MARKET.0

READING FILES
PROCESSING DATA

PLOT DATA
NUMBER OF COLUMNS = 19
NUMBER OF ROWS = 10
NUMBER OF TILES 4
NUMBER OF TILES HORIZONTALLY 4
NUMBER OF TILE VERTICALLY 1

Tile 1: Row 1 Column 1

Please Ensure Fresh Paper Is In The Plotter.
Press RETURN When Ready...

Please Ensure Pen 3 Is In Holder 1.
Press RETURN When Ready...

If you use the Precedence method, the DPM screen will be similar to the one that follows.

Please Wait...
Reading Plan And Report Files
There Are 41 Nodes In The Time Window

Positioning Nodes
There Are 4 Rows And 20 Columns

Positioning Links

Begin Plotting

Tile 1: Row 1 Column 1

Please Ensure Fresh Paper Is In The Plotter.
Press RETURN When Ready...

Please Ensure Pen 3 Is In Holder 1.
Press RETURN When Ready...

The file that PERTPLOTTER is reading is the project plan that you selected to draw. After it reads the files, PERTPLOTTER knows how large your drawing will be and gives you a readout of the number of columns and rows that will be drawn. PERTPLOTTER refers to a sheet of paper as a "Tile," and marks each sheet with corner hatches that will enable you to line up the tiles in your drawing.

Be sure that your drawing device is plugged in and turned on. When it is ready to begin, PERTPLOTTER will ask you to **Ensure Fresh Paper Is In The Plotter**. When you have checked your paper and are ready to start, press **RETURN**. PERTPLOTTER will begin to draw your project plan.

When it has completed drawing the first tile, PERTPLOTTER will again ask you to **Ensure Fresh Paper Is In The Plotter**. Remove the first tile and insert a second sheet of paper. When you are ready, press **RETURN**. PERTPLOTTER will proceed with the second tile of your drawing. This sequence of steps will be repeated as many times as there are tiles in the drawing. When PERTPLOTTER reaches the last tile, it will return you to the Main Menu.

If you are using a plotter that has fewer penholders than the number of colors you have selected, PERTPLOTTER will ask you to rotate pens, giving you specific instructions as to which pens to place in which penholders. PERTPLOTTER will keep track of the changes it has requested, so it will always know what color pen to expect in each holder. Assuming, that is, that you follow the directions displayed on the screen.

PERTPLOTTER will ask you, for example, to **Ensure Pen 5 Is In Holder 2**, and then **Press RETURN When Ready**. Make the necessary pen change and press **RETURN**.

You can end a drawing session a any time, even if you are in the middle of a tile. All you need to do is press **ESCAPE** once. PERTPLOTTER will return you to the Main Menu, but the drawing device may continue to operate for a moment or two longer. Do not press **ESCAPE** repeatedly. Your drawing device must empty its buffer before it will stop. In most cases, this means that your drawing device will complete the tile it was working on when you halted the drawing session.

You are now ready to end your first drawing session. Type **7** to **End The Session**. If you have made no changes since the last time you saved them PERTPLOTTER will end itself and return you to the operating system. If you have made any changes, PERTPLOTTER will first ask you if you want to save them before allowing you to call it a day.

The next (and last) chapter describes the housekeeping functions that we did not cover in Chapter 4.

DELETING FILES

Selecting the first option on this menu allows you to **Delete Drawing Specification File**. The only time that you would select this option is when you are completely finished with a drawing specification file, when you foresee no further applications or modifications you might wish to make, and therefore, you wish to delete the file from your data disk. One you delete a file, you cannot recover it, so please be sure that deleting is what you really want to do.

Type *1* to **Delete Drawing Specification File**. A screen similar to the one that follows will be displayed. It will contain a list of all of your drawing specification files.

```
*****
* PLAN : MARKET v. 0      *      PERTPLOTTER      * DEV : HP 7475      *
* SPEC : DEFAULT          *                               * PAPER : 8.5 x 11 in *
*****
```

Which Specification Would You Like To Delete :-

- 1: DEFAULT
- 2: AARDVARK
- 3: TESTSAMP
- 4: QWIKPLOT
- 5: LONGWAY
- 6: NONE OF THESE

Please Press The Number Of Your Choice : []

Or Press ? For Additional Information.

Type **?** to display additional information about how to locate the file you want to delete. Once you have located the file, all you have to do to delete it is type in the number next to the file name. PERTPLOTTER will delete the file you have selected and will return you to the Housekeeping Menu.

If you press **RETURN**, you will automatically select the first file on the list to be deleted. If you press **ESCAPE**, you will exit from this option without having deleted a file. This is a good thing to know if you wander into this option by mistake.

You can also scroll through the list of specifications in PERTPLOTTER's directory by typing **N** or pressing the **DOWN ARROW** to see the next part of the list. You can return to the previous part of the list by typing **P** or pressing the **UP ARROW**. If you know the name of the file that you wish to delete and do not want to take the time to scroll through the directory, you can enter the name of the file manually by first typing **M** to start manual load. You then can type in the name of the file you want to delete. Press **RETURN**.

SCALING FACTORS

Scaling factor refers to the relative proportions of the horizontal and vertical dimensions of your drawing. PERTPLOTTER allows you to shrink or enlarge either the horizontal or vertical dimension of your drawing. This is useful, for example, when you want to get all of a 3-tile drawing on a single sheet of paper. It also comes in handy when you want to zero in on a single segment of your drawing and enlarge it to show a complicated set of interconnections.

Type **6** to select **Scaling Factors**. A screen similar to the one that follows will be displayed.

* PLAN : MARKET v. 0 *
* SPEC : DEFAULT *

PERTPLOTTER

* DEV : HP 7475 *
* PAPER : 8.5 x 11 in *

Do You Want To :-

- 1: Specify Horizontal Scaling Factor ?
- 2: Specify Vertical Scaling Factor ?
- 3: Specify Default For Both ?
- 4: Return To Main Menu ?
- 5: Return To Previous Menu ?

Please Press The Number Of Your Choice : []

Or Press ? For Additional Information.

Type ? to display additional information about scaling factors. The first factor we'll deal with is the horizontal, so type **1** to **Specify Horizontal Scaling Factor**. PERTPLOTTER will highlight an area on the right of the screen and ask you to **Enter The Scaling Factor Of Your Choice**.

The value that you enter must be in decimal form (for example, .5 for one-half). The default value for the horizontal plane is 1. All entries are in relation to that default. This means that if you type **2**, the new horizontal scale will be twice the default. If you type **.5**, the new scale will be half of the original default. You can enter a number of up to six digits. This, of course, would give you a drawing so large that it would take several trees' worth of paper and a light-year or two to plot it. You can also enter a value with up to four places after the decimal. It would produce a microscopic drawing, but PERTPLOTTER is willing if you are. The most practical scaling factors are not greater than 10 nor less than .1.

Type in the horizontal scaling factor you wish to use and press **RETURN**. PERTPLOTTER will register your selection and ask you to choose another number. TYPE 2 to **Specify Vertical Scaling Factor**. The same rules and constraints apply to vertical scaling factors as do to horizontal. Make your selection and press **RETURN**.

The third alternative on the Scaling Factor Menu is **Specify Default For Both**. This allows you to return to the original default values for both horizontal and vertical scales. Select this option by typing 3. For the time being, let's use the original default values. Type 3. PERTPLOTTER will register your selection and ask for another choice. Type 4 if you want to **Return To Main Menu** or 5 if you want to **Return To Previous Menu** (Housekeeping).

DRAWING REPAIR OPTIONS

There comes a time, according to Murphy, when someone will set a coffee cup down on tile 9 of a 30-tile project plan a mere 15 minutes before you have to use the entire drawing as part of a presentation. Option 7, **Drawing Repair Options**, is designed to come to your rescue. It allows you to redraw any tile you want without having to redraw the entire project plan. It also allows you to redraw all of the tiles you list. Type 7 to **Specify Drawing Repair Options**. A menu similar to the one that follows will be displayed.

* PLAN : MARKET v. 0 *
* SPEC : DEFAULT *

PERTPLOTTER

* DEV : HP 7475 *
* PAPER : 8.5 x 11 in *

Do You Want To :-

- 1: Draw Tiles In List Only ?
- 2: Skip Tiles In List Only ?
- 3: Draw Or Skip Tiles With Prompt ?
- 4: Clear Drawing Repair Tile List ?
- 5: Return To Main Menu ?
- 6: Return To Previous Menu ?

Please Press The Number Of Your Choice : []

Or Press ? For Additional Information.

The first option on this menu allows you to list the specific tile(s) you want to draw. You can select it by typing **1**. PERTPLOTTER will highlight an area on the right side of the screen and ask you to **Specify The Tiles To Be Drawn**. You may list as many tiles as you like, but they must be separated in the list by slashes (/). You may also list an unbroken sequence of tiles by typing the first and last tiles of the sequence and separating them by a hyphen (-). For example, an entry might be: 1/5-7/10/18-54. PERTPLOTTER would then draw tiles 1, 5 through 7, 10, and 18 through 54. Press **RETURN** when your list is complete. This option may not be used with the one the follows.

The second option allows you to draw your entire project plan with the exception of any tile(s) you list. You can select the tile(s) you want to omit by typing **2** to **Skip Tiles In List Only**. PERTPLOTTER will highlight an area on the right of the screen and ask you to **Specify The Tiles To Be Skipped**. Again, you may list as many tiles as you like, separated by slashes. Press **RETURN** when your list is complete. This option may not be used with the first one on the menu.

You can use the third drawing repair option in conjunction with either of the first two. (You cannot, however, use the first two together.) The third option allows you to decide which tiles you want to draw on a tile-by-tile basis. This option is activated when you are producing a drawing. If you type **3** to **Draw Or Skip Tiles With Prompt**, PERTPLOTTER will stop before each tile is drawn and query you about drawing that tile. You can then choose to draw the tile or skip it. When you produce a drawing using the drawing repair options, PERTPLOTTER will prompt you by asking **Draw This Tile (Y or N)?**.

Option **4**, **Clear Drawing Repair Tile List** allows you to change your mind. You may use this option before you produce a drawing to clear any of the first three options that you may have set. This comes in handy if you select drawing repair options and then discover that you don't need to draw the tiles you had selected after all. Select this option by typing **4**.

Make your drawing repair selections and then type **5** if you want to **Return To Main Menu** or **6** if you want to **Return To Previous Menu** (Housekeeping).

OTHER HOUSEKEEPING FACILITIES

The other options on the Housekeeping Menu, which are fully explained in Section 5 of the Reference Manual, consist of facilities to configure your drawing device and select a data drive.

Even though these options are used only occasionally, we suggest that you glance at Reference Guide Sections 5.2 through 5.5 when you have finished with this chapter. When you actually have to use one of these facilities, you will find complete instructions in the applicable reference section.

REFERENCE MANUAL

PERTPLOTTERTM

Westminster
oftware

| <i>Section</i> | <i>Title</i> | <i>Page</i> |
|----------------|--------------------------------------|-------------|
| 1 | INTRODUCTION | 1-1 |
| 2 | MAIN MENU | 2-1 |
| 3 | SELECT DRAWING SPECIFICATIONS | 3-1 |
| 4 | SELECT PROJECT PLAN | 4-1 |
| 5 | HOUSEKEEPING | 5-1 |
| 5.1 | Delete Drawing Specification File | 5-3 |
| 5.2 | Specify Drawing Device | 5-5 |
| 5.3 | Specify Device Attachment | 5-8 |
| 5.4 | Specify Data Drive | 5-9 |
| 5.5 | Specify Temporary Drive File | 5-10 |
| 5.6 | Specify Scaling Factors | 5-11 |
| 5.7 | Specify Drawing Repair Options | 5-13 |
| 6 | EDIT DRAWING SPECIFICATIONS | 6-1 |
| 6.1 | Activities Menu | 6-3 |
| 6.2 | Links Menu | 6-5 |
| 6.3 | Milestones Menu | 6-7 |
| 6.4 | Time Window Menu | 6-8 |
| 6.4.1 | Start Date | 6-10 |
| 6.4.2 | End Date | 6-12 |
| 6.5 | Legend Menu | 6-14 |
| 6.5.1 | Additional Descriptions Menu | 6-17 |
| 6.6 | Color Menu | 6-20 |
| 6.7 | Line Style Menu | 6-23 |

| | | |
|------------|--|-----|
| 7 | SAVE CHANGES | 7-1 |
| 8 | PRODUCE A DRAWING | 8-1 |
| 9 | END A SESSION | 9-1 |
| | | |
| Appendix A | ERROR MESSAGES AND REMEDIES | A-1 |
| Appendix B | FILE DEFINITIONS | B-1 |

The PERTPLOTTER Reference Manual has been divided into a number of sections, carefully arranged so that you can use them easily. Although you will find the User's Guide helpful while you are getting to know PERTPLOTTER, the Reference Section format makes it faster to locate specific information.

We have organized this manual according to the sequence of menus and displays as they appear in the program. Thus, we have started with the Main Menu, which appears each time PERTPLOTTER is called, and have proceeded through each succeeding menu and sub-menu. We believe that this will allow you to follow a direct and logical sequence when using this manual.

The 9 major Reference Sections are as follows:

- Section 1 - Introduction
- Section 2 - Main Menu
- Section 3 - Drawing Specifications
- Section 4 - Project Plans
- Section 5 - Housekeeping
- Section 6 - Editing
- Section 7 - Saving Changes
- Section 8 - Producing a Drawing
- Section 9 - End of Session

Sections 5 and 6 are further broken down into more detailed sub-sections. You can go to these sub-sections directly, or be referred from a preceding section. In this way, you should be able to find the information you require with a minimum of time and effort expended.

MAIN MENU

PERTPLOTTER is loaded by typing **PERTPLOT** and pressing **RETURN**. After the copyright notice appears, the Main Menu will be displayed as shown below. If you type ? before you make a selection, additional information will be displayed at the bottom of the screen.

```
*****
* PLAN : MARKET v. 0      *      PERTPLOTTER      * DEV : HP 7475      *
* SPEC : DEFAULT         *                               * PAPER : 8.5 x 11 in *
*****
```

Do You Want To :-

- 1: Select Drawing Specification ?
- 2: Select Project Plan ?
- 3: Do Some Housekeeping ?
- 4: Examine Or Edit Current Drawing Specification ?
- 5: Save All Changes ?
- 6: Produce Drawing ?
- 7: End This Session ?

Please Press The Number Of Your Choice : []

Or Press ? For Additional Information.

1. Select Drawing Specification [See Section 3]

Selecting option **1** allows you to pick a Drawing Specifications file with which to work.

2. Select Project Plan [See Section 4]

Using option **2**, you select which project plan you wish to draw.

3. Do Some Housekeeping [See Section 5]

Housekeeping covers the preliminary work that must be done before a plan can be drawn, plus utilities for deleting files, selecting a data drive, specifying temporary file drives, selecting scaling factors, and selecting drawing repair options. It includes:

- Deleting specification files
- Selecting a drawing device and defining the way in which it will work with PERTPLOTTER
- Selecting a data drive
- Selecting a temporary file drive
- Selecting scaling factors
- Selecting drawing repair options

4. Examine or Edit Current Drawing Specifications [See Section 6]

It is with the editing option that you define the characteristics of the drawing that PERTPLOTTER will produce. The features you can choose from include:

- The activities you wish to show
- The way in which you want the links between them to be labeled
- Whether or not you wish milestone descriptions
- When you want your time window to start and finish
- Whether you wish to show a legend, and, if so, what you want the legend to look like and include
- What color you wish various features on your drawing to be
- Which style of line you wish to use for the different areas on your drawing

5. Save Changes to Current Drawing Specification [See Section 7]

Option 5 allows you either to save the existing drawing specification file or create a new one.

6. Produce Drawing [See Section 8]

When you select this option, you enter the drawing production mode. The drawing device port is initialized, a temporary file is created if necessary, and a drawing is produced.

7. End This Session [See Section 9]

Returns you to the computer's operating system.

**SELECT DRAWING
SPECIFICATION**

[Option 1 on Main Menu]

This section of PERTPLOTTER enables you to select a drawing specification. When you type *1* to **Select Drawing Specification**, the following menu, including a list of all available specifications, will be displayed.

NOTE: If you type *?* before making a selection, a list of all possible options will be displayed at the bottom of the screen.

```
*****
* PLAN : MARKET v. 0      *      PERTPLOTTER      *
* SPEC : DEFAULT         *
*****
*****
* DEV : HP 7475          *
* PAPER : 8.5 x 11 in   *
*****
```

Which Specification Would You Like To Use :-

- 1: DEFAULT v. 0
- 2: SAMPLE v. 0
- 3: NONE OF THESE

Please Press The Number Of Your Choice : []

Or Press ? For Additional Information.

There are two ways in which you can select your drawing specification. The first is by number from the display on your screen. The second is by manually typing in the name of the drawing specification you wish to use.

1. Select from Display

This option allows you to scroll through the list of drawing specifications displayed on the screen and select one of them by number.

If all of your drawing specification files are listed on the screen, you simply type the number of the one you wish to use. You may press RETURN to select the first option on the list, or ESCAPE to select the last option listed.

Your list of drawing specifications may be longer than will fit on a single screen display. To see other parts of your list, you can either press the UP ARROW or type *P* to see the previous part of the list, or press the DOWN ARROW or type *N* to see the next part of your list. You may then select from drawing specifications displayed and type the number of the file you want at the blinking prompt.

2. Manual Loading

If you know the exact eight-character name of the drawing specification you wish to use, you may elect to type in that name and load the drawing specification manually.

Type *M* to indicate that you wish to enter the name. Next, type the name of the file you wish to use and press RETURN. PERTPLOTTER will search its directory of available drawing specifications for the name you have typed. If the name is in the directory, PERTPLOTTER will load the file. If the name is not in the directory, an error message will appear instructing you to select another file.

SELECT PROJECT PLAN

[Option 2 on Main Menu]

This section of PERTPLOTTER enables you to select a project plan from among the ones that you created using PERTMASTER. Type 2 to **Select Drawing Specifications**. When you select this option, a screen similar to the one below, including a list of all available project plans, will be displayed. If you type ? before making a selection, a list of all possible options will be displayed at the bottom of your screen

```
*****
* PLAN : MARKET v. 0      *      PERTPLOTTER      * DEV : HP 7475      *
* SPEC : DEFAULT         *                               * PAPER : 8.5 x 11 in *
*****
```

Which Project Plan Would You Like To Use :-

- 1: MARKET v. 0
- 2: PRODUCT v. 0
- 3: HOUSE v. 0
- 4: NONE OF THESE

Please Press The Number Of Your Choice : []

Or Press ? For Additional Information.

There are two ways in which you can select the project plan you wish to draw. The first is by entering number from the display on your screen. The second is by manually typing in the name of the project plan you wish to use.

1. Select from Display

This option allows you to scroll through the list of project plans displayed on the screen and select one of them by number.

If all of your project plans are listed on the screen, you simply type the number of the one you wish to use. You may press **RETURN** to select the first option on the list, or **ESCAPE** to select the last option listed.

Your list of project plans may be longer than will fit on a single screen display. To see other parts of your list, you can either press the **UP ARROW** or type **P** to see the previous part of the list, or press the **DOWN ARROW** or type **N** to see the next part of your list. You may then select from the project plans displayed and type the number of the plan you want.

2. Manual Loading

If you know the exact eight-character name of the project plan you wish to use, you may elect to type in that name and load the project plan manually.

Type **M** to indicate that you wish to enter the name. Next, type the name of the plan you wish to use and press **RETURN**. **PERTPLOTTER** will search its directory of available project plans for the name you have typed. If the name is in the directory, **PERTPLOTTER** will load the plan. **PERTPLOTTER** will then ask you **Enter The Version Number** of the project plan you have selected. Do so by typing the number. Press **RETURN**.

If the name is not in the directory, an error message will appear instructing you to select another plan.

1. **Delete Drawing Specification File** [See Section 5.1]
Drawing specification files that are no longer needed can be deleted to increase available disk space.
2. **Specify Drawing Device** [See Section 5.2]
In order to create a drawing, PERTPLOTTER must know what drawing device you intend to use. If your drawing device can utilize more than one size sheet of paper, you must also specify what paper size you plan to use. Once you have completed this option, you need not make any changes unless you want to use another drawing device.
3. **Specify Device Attachment** [See Section 5.3]
This option tells PERTPLOTTER at which port your drawing device is attached to your computer.
4. **Specify Data Drive** [See Section 5.4]
PERTPLOTTER needs to know in which disk drive your PERTMASTER project plans are located.
5. **Specify Temporary File Drive** [See Section 5.5]
If you are using a printer as your drawing device, or plan to produce drawings of a Precedence network, this option tells PERTPLOTTER where to create the temporary file it will use to format your drawing.
6. **Specify Scaling Factors** [See Section 5.6]
Drawings can be increased or decreased, both horizontally or vertically, according to your requirements.
7. **Specify Drawing Repair Options** [See Section 5.7]
This set of options allows you to draw selected tiles from your project plan without having to reproduce the entire plan.
8. **Return to Main Menu**
Returns you to the Main Menu.

DELETE DRAWING SPECIFICATION FILE [Option 1 on Housekeeping Menu]

If at some point you have no further need for any of your drawing specification files, you have the option of deleting them from your directory. This option is useful in creating additional available disk space. Press **1** from the Housekeeping Menu to **Delete Drawing Specification File**. The following screen including a list of all drawing specification files in your directory will be displayed.

```
*****
* PLAN : MARKET v. 0      *      PERTPLOTTER      * DEV : HP 7475      *
* SPEC : DEFAULT          *
*****
*****
* PAPER : 8.5 x 11 in    *
*****
```

Which Specification Would You Like To Delete :-

- 1: DEFAULT
- 2: AARDVARK
- 3: TESTSAMP
- 4: QWIKPLOT
- 5: LONGWAY
- 6: NONE OF THESE

Please Press The Number Of Your Choice : []

Or Press ? For Additional Information.

There are two ways in which you can select the drawing specification you wish to delete. The first is by entering number from the display on your screen. The second is by manually typing in the name of the drawing specification to be deleted.

1. Select from Display

This option allows you to scroll through the list of drawing specification files displayed on the screen and select one of them by number.

If all of your drawing specifications are listed on the screen, you simply type the number of the one you wish to delete. You may press **RETURN** to select the first option on the list, or **ESCAPE** to select the last option listed.

Your list of drawing specifications may be longer than will fit on a single screen display. To see other parts of your list, you can either press the **UP ARROW** or type **P** to see the previous part of the list, or press the **DOWN ARROW** or type **N** to see the next part of your list. You may then select from the drawing specifications displayed and type the number of the plan you want to delete.

2. Manual Loading

If you know the exact eight-character name of the drawing specification you wish to delete, you may elect to type in that name and save the time it takes to scroll through your list.

Type **M** to indicate that you wish to enter the name. Next, type the name of the specification you wish to delete and press **RETURN**. **PERTPLOTTER** will search its directory of available drawing specifications for the name you have typed. If the name is in the directory, **PERTPLOTTER** will delete the specification.

If the name is not in the directory, an error message will appear instructing you to select another option.

**SPECIFY DRAWING
DEVICE**

[Option 2 on Housekeeping Menu]

PERTPLOTTER simplifies the procedure of configuring and initializing your drawing device by keeping track of what type of drawing device you use and the requirements of that device. All you need to tell PERTPLOTTER is what type of device you plan to use. If your drawing device can utilize more than one size sheet of paper, you must also specify what paper size you plan to use. From the Housekeeping Menu type **2** to **Specify Drawing Device**. A screen similar to the one that follows will appear, listing all of the drawing devices that PERTPLOTTER recognizes.

```
*****
* PLAN : MARKET v. 0      *      PERTPLOTTER      *
* SPEC : DEFAULT         *      *
*****
*****
* DEV : HP 7475          *
* PAPER : 8.5 x 11 in   *
*****
```

Which Device Are You Going To Use :-

- 1: HP 7475
- 2: HP 7470
- 3: Six Shooter
- 4: Sweet-P
- 5: Epson MX-80 w/Graftrax
- 6: Epson MX-100 w/Graftrax
- 7: Epson FX-80
- 8: MORE SELECTIONS

Please Press The Number Of Your Choice : []

Or Press ? For Additional Information.

If your drawing device is the first one listed, you may select it by pressing **RETURN**. You may select another device on the list by typing in the number listed for that device. If your drawing device is not listed, type **8** to see the second portion of this device list. You may also press either **N** or the **DOWN ARROW** to see the next portion of the list. A screen similar to the one that follows will be displayed.

```
*****
* PLAN : MARKET v. 0      *      PERTPLOTTER      *
* SPEC : DEFAULT         *
*****
*****
* DEV : HP 7475          *
* PAPER : 8.5 x 11 in   *
*****
```

Which Device Are You Going To Use :-

- 1: Epson FX-100
- 2: IBM Graphics Printer
- 3: HP ThinkJet
- 4: HP LaserJet
- 5: NONE OF THESE

Please Press The Number Of Your Choice : []

Or Press ? For Additional Information.

If your drawing device is listed, type the number next to it to select it. You may press either **P** or the **UP ARROW** to return to the previous portion of this list. Press **ESCAPE** if you wish to exit from this option without having to make a choice.

Some drawing devices use more than one size sheet of paper. If your drawing device can use two different sizes of paper, PERTPLOTTER will automatically display the screen that follows.

```
*****
* PLAN : MARKET v. 0      *      PERTPLOTTER      * DEV : HP 7475      *
* SPEC : DEFAULT          *                               * PAPER : 8.5 x 11 in *
*****
```

What Is The Size Of Your Paper :-

- 1: 8.5 x 11 in
- 2: 17 x 11 in
- 3: NONE OF THESE

Please Press The Number Of Your Choice : []

Or Press ? For Additional Information.

Select the size of paper you intend to use by typing the appropriate number from those displayed on the screen.

Some drawing devices also support more than one type of paper feed mechanism. If your drawing device is one of these, PERTPLOTTER will automatically display a Paper Feed Menu similar to the one that follows.

* PLAN : MARKET v. 0 *
* SPEC : DEFAULT *

PERTPLOTTER

* DEV : HP 7475 *
* PAPER : 8.5 x 11 in *

Is Your Paper Feed Mechanism :-

- 1: Continuous Form ?
- 2: Single Sheet ?
- 3: NONE OF THESE

Please Press The Number Of Your Choice : []

Or Press ? For Additional Information.

Select the correct paper feed mechanism by typing the appropriate number. For PERTPLOTTER's purposes, roll paper, fan fold, and drawing devices with mechanical paper feeders are all considered to be continuous form. PERTPLOTTER will register your selection and will automatically return you to the Housekeeping Menu.

This option must be completed as part of the start-up procedure when you use PERTPLOTTER for the first time. You need not use this option again unless you wish to change drawing devices, paper size, or paper feed.

**SPECIFY DEVICE
ATTACHMENT**

[Option 3 on Housekeeping Menu]

In order to properly initialize and transmit drawing instructions to your printer or plotter, PERTPLOTTER must know the name of the port at which you have attached your drawing device. To supply this information, type 3 to **Specify Device Attachment**. The following screen will appear.

```
*****
* PLAN : MARKET v. 0      *      PERTPLOTTER      * DEV : HP 7475      *
* SPEC : DEFAULT          *                               * PAPER : 8.5 x 11 in *
*****
```

Do You Want To :-

- 1: Delete Drawing Specification File ?
 - 2: Specify Drawing Device ?
 - 3: Specify Device Attachment ?
 - 4: Specify Data Drive ?
 - 5: Specify Temporary File Drive ?
 - 6: Specify Scaling Factors ?
 - 7: Specify Drawing Repair Options ?
 - 8: Return To Main Menu ?
- COM1
b:
a:

Please Specify Your Device Attachment : []

Or Press ? For Additional Information.

When the blinking prompt appears, type in the name of the port to which your drawing device is attached. For most systems, your drawing device will be attached to one of the first two ports, COM1 or COM2.

Please note that PERTPLOTTER is looking for the name of the port, not the type of connector you are using. Check your drawing device and computer user's manuals if you are unsure of the name of the port.

SPECIFY DATA DRIVE

[Option 4 on Housekeeping Menu]

The Data Drive is the disk drive that contains your PERTMASTER project plans, information that is essential to creating a drawing. Type 4 to **Specify Data Drive**. The following screen will appear.

```
*****
* PLAN : MARKET v. 0      *      PERTPLOTTER      * DEV : HP 7475      *
* SPEC : DEFAULT          *                               * PAPER : 8.5 x 11 in *
*****
```

Do You Want To :-

- 1: Delete Drawing Specification File ?
- 2: Specify Drawing Device ?
- 3: Specify Device Attachment ? COM1
- 4: Specify Data Drive ? a:
- 5: Specify Temporary File Drive ? b:
- 6: Specify Scaling Factors ?
- 7: Specify Drawing Repair Options ?
- 8: Return To Main Menu ?

Please Specify Your Data Drive :

Or Press ? For Additional Information.

When the blinking prompt appears, type in the name of the data drive in which your PERTMASTER project plans are located, and press **RETURN**. For most systems, your data disk will be located in drive B.

**SPECIFY SCALING
FACTORS**

[Option 6 on Housekeeping Menu,

PERTPLOTTER allows you to set relative horizontal and vertical scales for all drawings. Using the scaling factor option, you can shrink or enlarge either the horizontal or vertical dimension of your drawing. This option can be used to shrink a 3-tile dummy onto a single sheet of paper, or to enlarge a single connection to fill a complete tile.

Type **6** to select **Scaling Factors**. A Scaling Factors Menu similar to the one that follows will be displayed. If you type **?** before making a selection, additional information about scaling factors will be displayed at the bottom of the screen.

```
*****
* PLAN : MARKET v. 0      *      PERTPLOTTER      * DEV : HP 7475
* SPEC : DEFAULT          *
*****
*****
* PAPER : 8.5 x 11 in    *
```

Do You Want To :-

- 1: Specify Horizontal Scaling Factor ?
- 2: Specify Vertical Scaling Factor ?
- 3: Specify Default For Both ?
- 4: Return To Main Menu ?
- 5: Return To Previous Menu ?

Please Press The Number Of Your Choice : []

Or Press ? For Additional Information.

1. **Specify Horizontal Scaling Factor** [Option 1 on Scaling Factor Menu]

Type **1** to **Specify Horizontal Scaling Factor**. PERTPLOTTER will highlight an area on the right of the screen and ask you to **Enter The Scaling Factor Of Your Choice**.

The default value for the horizontal plane is 1. All entries are in relation to that default. This means that if you type **2**, the new horizontal scale will be twice the default. If you type **.5**, the new scale will be half of the original default. You can enter a number of up to six digits, or up to four places after the decimal. Type in your horizontal scale factor and press **RETURN**.

2. **Specify Vertical Scaling Factor** [Option 2 on Scaling Factor Menu]

Type **2** to **Specify Vertical Scaling Factor**. PERTPLOTTER will highlight an area on the right of the screen and ask you to **Enter The Scaling Factor Of Your Choice**.

Like the horizontal scaling factor, the vertical factor is in relation to the default value of 1. Your entry can be up to six digits or four digits after the decimal. Type in your vertical scale factor and press **RETURN**.

3. **Specify Default For Both** [Option 3 on Scaling Factor Menu]

You can, of course, set the scaling factor for both horizontal and vertical planes to the default value of 1. This will reset PERTPLOTTER to the original default size for both horizontal and vertical. Type **3** to **Specify Default For Both**. PERTPLOTTER will reinitialize to the default value.

4. **Return To Main Menu** [Option 4 on Scaling Factor Menu]

Returns you to the Main Menu.

5. **Return To Previous Menu** [Option 5 on Scaling Factor Menu]

Returns you to the Housekeeping Menu.

**SPECIFY DRAWING REPAIR
OPTIONS**

[Option 7 on Housekeeping Menu]

This set of options allows you to redraw a single tile from a project plan or as many tiles as are needed without having to redraw the entire plan. Type 7 to **Specify Drawing Repair Options**. A Drawing Repair menu similar to the one that follows will be displayed.

Because this is a repair facility, none of the options in this menu are permanent. PERTPLOTTER will save the changes you make here only until you produce a drawing. You should produce a drawing immediately after using this option. If you type ? before making a selection, additional information will be displayed at the bottom of the screen.

```
*****
* PLAN : MARKET v. 0      *      PERTPLOTTER      * DEV : HP 7475      *
* SPEC : DEFAULT          *                               * PAPER : 8.5 x 11 in *
*****
```

Do You Want To :-

- 1: Draw Tiles In List Only ?
- 2: Skip Tiles In List Only ?
- 3: Draw Or Skip Tiles With Prompt ?
- 4: Clear Drawing Repair Tile List ?
- 5: Return To Main Menu ?
- 6: Return To Previous Menu ?

Please Press The Number Of Your Choice : []

Or Press ? For Additional Information.

1. Draw Tiles In List Only [Option 1 on Drawing Repair Menu]

This option allows you to list the specific tile(s) you want to draw. Select this option by typing *1*. PERTPLOTTER will highlight an area on the right side of the screen and ask you to **Specify The Tiles To Be Drawn**. Enter the tile numbers that you wish to draw. You may list as many tiles as you like, but they must be separated in the list by slashes (/). You may also list an unbroken sequence of tiles by typing the first and last tiles of the sequence and separating them by a hyphen (-). For example, if you type *1/5-7/10/18-33*, PERTPLOTTER will draw tiles 1, 5 through 7, 10, and 18 through 33. Press **RETURN** at the end of your list. This option may not be used with the one that follows.

2. Skip Tiles In List Only [Option 2 on Drawing Repair Menu]

The second drawing repair option allows you to draw an entire project plan with the exception of any tile(s) you list. Select the tile(s) you want to omit by typing *2* to **Skip Tiles In List Only**. PERTPLOTTER will highlight an area on the right of the screen and ask you to **Specify The Tiles To Be Skipped**. List the tile(s) you want to skip, separated by slashes. You may also list an unbroken sequence of tiles by typing the first and last tiles of the sequence and separating them by a hyphen (-). Then press **RETURN** at the end of your list. This option may **not** be used with the preceding one.

3. Draw Or Skip Tiles With Prompt [Option 3 on Drawing Repair Menu]

The third drawing repair option may be used in conjunction with either of the first two. It allows you to decide which tiles to draw on a tile-by-tile basis. This option is activated in the drawing production mode. To active this option, type *3* to **Draw Or Skip Tiles With Prompt**. During the drawing process, PERTPLOTTER will stop before each tile is drawn and query you about drawing that tile. You can then choose to draw the tile or skip it.

4. Clear Drawing Repair Tile List [Option 4 on Drawing Repair Menu]

This drawing repair option effectively cancels any of the three drawing repair options above if it is used before a drawing is produced. It allows you to change your mind about making drawing repairs before you produce a drawing. To select this option, type *4*. PERTPLOTTER will cancel any of the first three options that you may have selected.

5. Return To Main Menu [Option 5 on Drawing Repair Menu]
Returns you to the Main Menu.

6. Return To Previous Menu [Option 6 on Drawing Repair Menu]
Returns you to the Housekeeping Menu.

**EXAMINE OR EDIT CURRENT
DRAWING SPECIFICATIONS**

[Option 4 on Main Menu]

Examine or Edit consists of seven functions that define all of the different types of drawings that PERTPLOTTER can produce. This is your opportunity to specify exactly what elements you want to see on your drawing as well as the way in which you want the elements to be presented. From the Main Menu, type 4 to **Examine or Edit Current Drawing Specifications**, and the screen shown below will appear.

If you type ? before making a selection, additional information will be displayed at the bottom of the screen. You may select the options listed in the Edit Menu in any order.

```
*****
* PLAN : MARKET v. 0      *      PERTPLOTTER      * DEV : HP 7475      *
* SPEC : DEFAULT          *                               * PAPER : 8.5 x 11 in *
*****
```

Which Of The Following Items Do You Wish To Edit ?

- 1: Activities.
- 2: Links.
- 3: Milestones.
- 4: Time Window.
- 5: Legend.
- 6: Color.
- 7: Line Style.
- 8: Return To Main Menu.

Please Press The Number Of Your Choice : []

Or Press ? For Additional Information.

1. **Activities** [See Section 6.1]
You may select any or all of the activity items available to you. They include duration, float, description, start and finish times.
2. **Links** [See Section 6.2]
You may also select from among the various Precedence link labels that are available to you.
3. **Milestones** [See Section 6.3]
This option allows you to include the milestones and descriptions from your PERTMASTER project plan in your drawing.
4. **Time Window** [See Section 6.4]
PERTPLOTTER needs to know when to begin your drawing and when to end it. This option allows you to set start and end dates for the portion of your project plan you wish to draw.
5. **Legend** [See Section 6.5]
The legend is often an important information device to enable you to pinpoint which version of a plotter project plan you are currently using. You can include or exclude as much of the legend material as you want.
6. **Color** [See Section 6.6]
If you are using a plotter, you have the option of using different colors for the four types of lines in a PERTPLOTTER drawing.
7. **Line Style** [See Section 6.7]
There are four styles of lines that you can use to differentiate among the elements in you drawing.
8. **Return to Main Menu**
Returns you to the Main Menu

ACTIVITIES

[Option 1 on Edit Menu]

Activities form the core of information that will be conveyed by your drawing. Press **I** from the Edit Menu to select which **Activities** you wish to include in your drawing.

If you press **?** before you make a selection, additional information will be displayed at the bottom of the screen.

```

*****
* PLAN : MARKET v. 0      *      PERTPLOTTER      * DEV : HP 7475      *
* SPEC : DEFAULT          *                               * PAPER : 8.5 x 11 in *
*****

```

Which Of The Activity Items Should Be Included In Your Drawing ?

- | | | |
|----|--------------------------|-----|
| 1: | Duration. | Yes |
| 2: | Total Float. | Yes |
| 3: | Description. | Yes |
| 4: | Early Start And Finish. | Yes |
| 5: | Late Start And Finish. | Yes |
| 6: | Return To Main Menu. | |
| 7: | Return To Previous Menu. | |

Please Press The Number Of Your Choice : []

Or Press ? For Additional Information.

The current specifications are displayed on the right side of your screen. You may alter any of them by typing the number of the activity item you wish to change. After you have finished making any necessary changes to activity items, you may select option **6** to **Return To Main Menu** if you have no futher editing changes to make. If you wish to continue editing, select option **7** to **Return To Previous Menu**. See steps 6 and 7 below for further instructions.

1. Duration

The duration is the amount of time it takes to complete an activity.
Type **1** to change the current **Duration** specification.

2. Total Float

Float indicates the amount of time an activity can be delayed without affecting the outcome of the project. Type **2** to change the current **Total Float** specification.

3. Description

Type **3** to change the current **Description** specification.

4. Early Start and Finish

Type **4** to change the current **Early Start And Finish** specification.

5. Late Start and Finish

Type **5** to change the current **Late Start And Finish** specification.

6. Return To Main Menu

Type **6** to return to the Main Menu.

7. Return To Previous Menu

Type **7** to return to the Edit Menu.

LINKS

[Option 2 on Edit Menu]

This option applies only if you have used the Precedence method of network analysis in PERTMASTER. The Links option has no meaning for you if you intend to draw an Arrow Plan. If you used the Precedence method, you can designate which links are to be labeled in your drawing. Type 2 to select **Links**. The following screen will be displayed.

If you type ? before making any selections, additional information will be displayed at the bottom of the screen.

```
*****
* PLAN : MARKET v. 0      *      PERTPLOTTER      * DEV : HP 7475      *
* SPEC : DEFAULT          *                               * PAPER : 8.5 x 11 in *
*****
```

Which Of The Link Items Should Be Included In Your Drawing ?

- 1: Start-Start Label And Duration. Yes
- 2: Finish-Start Label And Duration. Yes
- 3: Finish-Finish Label And Duration. Yes
- 4: Do You Wish To Draw Links To and From Activities Omitted From The Plot. Yes
- 5: Return To Main Menu.
- 6: Return To Previous Menu.

Please Press The Number Of Your Choice : []

Or Press ? For Additional Information.

The current specifications are displayed on the right side of your screen. You may alter any of the specifications by typing the number of the link label you wish to change.

1. Start-Start Label And Duration

The Start-Start link runs from the beginning of one activity to the beginning of the next. You need do nothing if the current value is set correctly. Type *1* to change the current **Start-Start Label And Duration specification**.

2. Finish-Start Label And Duration

The Finish-Start link runs from the end of one activity to the beginning of the next. You need do nothing if the current value is set correctly. Type *2* to change the current **Finish-Start Label And Duration specification**.

3. Finish-Finish Label And Duration

The Finish-Finish link runs from the end of one activity to the end of the next activity. You need do nothing if the current value is correctly set. Type *3* to change the current **Finish-Finish Label And Duration specification**.

4. Do You Wish To Draw Links To And From Activities Omitted From The Plot?

You have the option of drawing links to activities that are not part of your current drawing. You need do nothing if the current value is set correctly. Type *4* if you wish to change the current specification.

5. Return To Main Menu

Type *5* to return to the Main Menu.

6. Return To Previous Menu

Type *6* to return to the Edit Menu.

MILESTONES

[Option 3 on Edit Menu]

The Milestones option applies to users of both Arrow and Precedence Plans. To select this option, type 3 from the Edit Menu. The following screen will be displayed.

If you type ? before making a selection from the Milestones Menu, additional instructions will be displayed at the bottom of the screen.

```
*****
* PLAN : MARKET v. 0      *      PERTPLOTTER      * DEV : HP 7475      *
* SPEC : DEFAULT          *                               * PAPER : 8.5 x 11 in *
*****
```

Do You Wish To Draw The Milestones With Descriptions ? Yes

Please Press The Number Of Your Choice : []

Or Press ? For Additional Information.

The current setting of the Milestone option is shown on the right of the screen. After you make your selection, you will automatically be returned to the Edit Menu.

Type Y if you wish to include milestone descriptions in your drawing. Type N if you do not wish to include milestone descriptions in your drawing.

TIME WINDOW

[Option 4 on Edit Menu]

The Time Window of your drawing determines what period of time your drawing includes. It is defined by specifying start and end dates. Type **4** from the Edit Menu to define your **Time Window**. The following screen will appear.

If you type **?** before you make a selection from the Time Window menu, information about the correct format in which to specify a date will be shown at the bottom of the screen.

```
*****
* PLAN : MARKET v. 0      *      PERTPLOTTER      * DEV : HP 7475      *
* SPEC : DEFAULT          *                               * PAPER : 8.5 x 11 in *
*****
```

Please Define A Time Window :-

- | | | |
|----|--------------------------|--------|
| 1: | Start Date : | START |
| 2: | End Date : | FINISH |
| 3: | Entire Project. | |
| 4: | Return To Main Menu. | |
| 5: | Return To Previous Menu. | |

Please Press The Number Of Your Choice : []

Or Press **?** For Additional Information.

1. **Start Date** [See Section 6.4.1]
Selecting this option allows you to define the beginning of your time window.
2. **End Date** [See Section 6.4.2]
Option **2** allows you to define the end of your time window.
3. **Entire Project**
If you select this option by typing **3**, your entire project plan will be included in your drawing. This means that your start date will automatically be set to **START** and your end date will be automatically set to **FINISH**.
PERTPLOTTER will then ask you to **Please Enter The Number Of Your Choice**. If you have finished editing your drawing specification, you may return to the Main Menu. If you wish to continue editing, return to the Editing Menu. See steps 4 and 5 below for specific instructions.
4. **Return To Main Menu**
Type **4** to return to the Main Menu.
5. **Return To Previous Menu**
Type **5** to return to the Edit Menu.

START DATE

[Option 1 on Time Window Menu]

The current start and end dates are shown on the right of the screen. There are two ways in which you can define the time window of your drawing. The first is by setting start and end dates; the second is by designating the entire project (see Section 6.4). You can select the **Start Date** option by typing **1** from the Time Window Menu. The following screen will appear.

```
*****
* PLAN : MARKET v. 0      *      PERTPLOTTER      * DEV : HP 7475      *
* SPEC : DEFAULT          *                               * PAPER : 8.5 x 11 in *
*****
```

Please Define A Time Window :-

```
1: Start Date :                27/AUG/84
2: End Date :                  12/MAR/85
3: Entire Project.
4: Return To Main Menu.
5: Return To Previous Menu.
```

Please Press The Number Of Your Choice : []

Or Press ? For Additional Information.

PERTPLOTTER will ask you to **Enter Start Date of Time Window**, and will highlight a section on the right of the screen where your start date will be displayed. You can enter a start date in one of three ways. Select one of the three methods listed below.

1. Enter Date

You may define the start of your time window by typing in the date as of which you wish your drawing to start. Then press **RETURN**. The correct format is **DD/MMM/YY**. An example would be **27/AUG/84**.

If the date you have selected is within the time frame of your project plan, PERTPLOTTER will register the start date on the right of the screen. If the start date you have selected is before the beginning of your project plan, PERTPLOTTER will display the date you have selected and assume that you want to begin your drawing on the start date. If the start date you have selected is after the end of your project, an error message will inform you of the ineligible date and will request that you enter an accurate date.

PERTPLOTTER will then ask you to **Press The Number Of Your Choice**. Type **2** to set **End Date**.

2. Enter Day

You may also define your start date by typing in any number of working days after the beginning of the project. Then press **RETURN**. An example would be **25**. Entering 25 would start your drawing on the twenty-fifth working day of your project plan.

If you select a number of working days, PERTPLOTTER will automatically display the correct date that corresponds to the number of days you have chosen.

PERTPLOTTER will then ask you to **Press The Number Of Your Choice**. Type **2** to set **End Date**.

3. Enter START

As a third alternative, PERTPLOTTER also recognizes the word **START** and the letter **S** as valid starting dates. You may type either **START** or **S**, then press **RETURN**. PERTPLOTTER will register **START** as the start date.

PERTPLOTTER will then ask you to **Press The Number Of Your Choice**. Type **2** to set **End Date**.

The start date or days must be earlier than the finish date or days. If, for some reason, this is not the case, PERTPLOTTER will inform you that an invalid time window exists.

END DATE

[Option 2 on Time Window Menu]

When you select option **2: End Date**, the following screen will appear, with a highlighted area on the right of the screen where your end date will be displayed.

```
*****
* PLAN : MARKET v. 0      *      PERTPLOTTER      * DEV : HP 7475      *
* SPEC : DEFAULT          *                               * PAPER : 8.5 x 11 in *
*****
```

Please Define A Time Window :-

```
1: Start Date :                27/AUG/84
2: End Date :                    12/MAR/85
3: Entire Project.
4: Return To Main Menu.
5: Return To Previous Menu.
```

Please Press The Number Of Your Choice : []

Or Press ? For Additional Information.

PERTPLOTTER will ask you to **Enter Finish Date of Time Window**. You can enter an end date in one of three ways. Select one of the three methods listed below.

1. Enter Date

You may define the end of your time window by typing in the date as of which you wish your drawing to end. Then press **RETURN**. The correct format is **DD/MMM/YY**. An example would be **12/MAR/85**.

If the date you have selected is within the time frame of your project plan, PERTPLOTTER will register the end date on the right of the screen. If the end date you have selected is after the completion of your project plan, PERTPLOTTER will display that date as the finish date and assume that you want to end your drawing on the final day of the project plan. If your end date is before the beginning of the project, an error message will inform you of the ineligible date and will request that you enter an accurate date.

PERTPLOTTER will then ask you to **Press The Number Of Your Choice**. If you have finished editing your drawing specification, you may **Return to Main Menu** by typing **4**. If you wish to continue editing, return to the Edit Menu by typing **5**.

2. Enter Day

You may also define your end date by typing in any number of working days after the beginning of the project. Then press **RETURN**. An example would be **65**. Entering **65** would end your drawing on the sixty-fifth working day of your project plan.

If you select a number of working days, PERTPLOTTER will automatically display the correct date that corresponds to the number of days you have chosen.

PERTPLOTTER will then ask you to **Press The Number Of Your Choice**. If you have finished editing your drawing specification, you may **Return to Main Menu** by typing **4**. If you wish to continue editing, return to the Edit Menu by typing **5**.

3. Enter FINISH

As a third alternative, PERTPLOTTER also recognizes the word **FINISH** and the letter **F** as valid ending dates. You may type either **FINISH** or **F**, then press **RETURN**. PERTPLOTTER will register **FINISH** as the end date.

PERTPLOTTER will then ask you to **Press The Number Of Your Choice**. If you have finished editing your drawing specification, you may **Return to Main Menu** by typing **4**. If you wish to continue editing, return to the Edit Menu by typing **5**.

The start date or days must be earlier than the finish date or days. If, for some reason, this is not the case, PERTPLOTTER will inform you that an invalid time window exists.

LEGENDS

[Option 5 on Edit Menu]

Although the legend box requires a few extra minutes of drawing time, most users have found that it is useful for providing documentation on their drawings. In the interests of time, however, you may choose to omit the legend from your drawing. Type 5 from the Edit Menu to examine or edit **LEGEND**.

The following screen, the Legend Menu, will appear. If you type ? before making a selection from the Legend Menu, additional information will appear at the bottom of the screen.

```
*****
* PLAN : MARKET v. 0      *      PERTPLOTTER      * DEV : HP 7475      *
* SPEC : DEFAULT          *
*****
*****
* PAPER : 8.5 x 11 in    *
*****
```

Which Items Should Be Included In Your Legend ?

- | | | |
|----|--------------------------|-----|
| 1: | Show Legend. | Yes |
| 2: | Left Title. | Yes |
| 3: | Center Title. | Yes |
| 4: | Right Title. | Yes |
| 5: | Drawing Date. | Yes |
| 6: | Additional Descriptions. | |
| 7: | Return To Main Menu. | |
| 8: | Return To Previous Menu. | |

Please Press The Number Of Your Choice : []

Or Press ? For Additional Information.

1. **Show Legend** [Option 1 on Legend Menu]

The first decision you must make with regard to legends is whether or not you wish to include one in your drawing. PERTPLOTTER will display a value on the right of the screen and will ask you to **Press The Number Of Your Choice**. Type **1** only if you wish to change the setting that is shown.

If you choose not to show a legend on your drawing, you may skip the rest of this option. Press **7** to **Return to Main Menu** if you have finished editing your drawing specification. If you wish to continue editing, return to the Edit Menu by typing **8**.

2. **Left Title** [Option 2 on Legend Menu]

This option refers to the Left Title you entered into your project plan while using PERTMASTER. PERTPLOTTER will display a value on the right of the screen and will ask you to **Press The Number Of Your Choice**. Type **2** only if you wish to change the setting that is shown.

3. **Center Title** [Option 3 on Legend Menu]

This option refers to the Center Title you entered into your project plan while using PERTMASTER. PERTPLOTTER will display a value on the right of the screen and will ask you to **Press The Number Of Your Choice**. Type **3** only if you wish to change the setting that is shown.

4. **Right Title** [Option 4 on Legend Menu]

This option refers to the Right Title you entered into your project plan while using PERTMASTER. PERTPLOTTER will display a value on the right of the screen and will ask you to **Press The Number Of Your Choice**. Type **4** only if you wish to change the setting that is shown.

5. **Drawing Date** [Option 5 on Legend Menu]

This option refers to the date on which your drawing will be made. This information can be useful in the event that you have more than one version of the same drawing. PERTPLOTTER will display a value on the right of the screen and will ask you to **Press The Number Of Your Choice**. Type **5** only if you wish to change the setting that is shown.

6. Additional Descriptions

[See Section 6.5.1]

Additional Descriptions refers to up to four lines of text that you can choose to include in your legend. Each of the four lines can contain up to 30 characters.

7. Return To Main Menu

[Option 7 on Legend Menu]

If you have completed any editing you wish to do, press **7** to **Return To Main Menu**.

8. Return to Previous Menu

[Option 8 on Legend Menu]

If you wish to continue editing, press **8** to **Return to Previous Menu**. You will be returned to the Edit Menu.

ADDITIONAL DESCRIPTIONS

Additional Descriptions refers to up to four lines of text that you can choose to include in your legend. Each of the four lines can contain up to 30 characters. Type **6** to select **Additional Descriptions**. The following menu will be displayed.

```
*****
* PLAN : MARKET v. 0      *      PERTPLOTTER      * DEV : HP 7475      *
* SPEC : DEFAULT          *                               * PAPER : 8.5 x 11 in *
*****
```

Please Define Your Additional Legend Lines:

- 1: Line 1: (line 1)
- 2: Line 2: (line 2)
- 3: Line 3: (line 3)
- 4: Line 4: (line 4)
- 5: Clear Line
- 6: Return To Main Menu
- 7: Return To Previous Menu

Please Press The Number Of Your Choice : []

Or Press ? For Additional Information.

1. Line 1 [Option 1 on Additional Legend Lines Menu]

You may add up to four lines of text containing a maximum of 30 characters each. Type **1** to select **Line 1** of additional text.

PERTPLOTTER will then ask you to **Enter Content Of This Line**. Your entry is limited to 30 characters per line. Enter the text you wish to include on the first line and press **RETURN**.

PERTPLOTTER will again ask you to **Press The Number Of Your Choice**. If you wish to add a second line of text, type **2**. If you have completed adding text and have no more editing to do on your drawing specification, press **6** to **Return to Main Menu**. If you wish to continue editing your legend, return to the Legend Menu by typing **7**.

2. Line 2 [Option 2 on Additional Legend Lines Menu]

Type **2** to select **Line 2** of additional text. PERTPLOTTER will then ask you to **Enter Content Of This Line**. Enter the text you wish to include on the second line and press **RETURN**.

PERTPLOTTER will again ask you to **Press The Number Of Your Choice**. If you wish to add a third line of text, Type **3**. If you have completed adding text and have no more editing to do on your drawing specification, press **6** to **Return to Main Menu**. If you wish to continue editing your legend, return to the Legend Menu by typing **7**.

3. Line 3 [Option 3 on Additional Legend Lines Menu]

Type **3** to select **Line 3** of additional text. PERTPLOTTER will then ask you to **Enter Content Of This Line**. Enter the text you wish to include on the third line and press **RETURN**.

PERTPLOTTER will again ask you to **Press The Number Of Your Choice**. If you wish to add a fourth line of text, Type **4**. If you have completed adding text and have no more editing to do on your drawing specification, press **6** to **Return to Main Menu**. If you wish to continue editing your legend, return to the Legend Menu by typing **7**.

4. Line 4 [Option 4 on Additional Legend Lines Menu]

Type **4** to select **Line 4** of additional text. PERTPLOTTER will then ask you to **Enter Content Of This Line**. Enter the text you wish to include on the fourth line and press **RETURN**.

PERTPLOTTER will again ask you to **Press The Number Of Your Choice**. If you have finished editing your drawing specification, press **6** to **Return to Main Menu**. If you wish to continue editing your legend, return to the Legend Menu by typing **7**.

5. **Clear Line** [Option 5 on Additional Legend Lines Menu]

This option allows you erase any or all of the lines of additional text you have entered. Select this option by typing **5** from the Additional Legend Lines Menu. PERTPLOTTER will then ask you to **Enter Line Number To Clear, Or Press Return For All.**

Type in the number of the line that you wish to eliminate, and that line will disappear from the display at the right of the screen. Repeat this procedure for any other lines you wish to erase. You may erase all of the lines by pressing **RETURN**.

PERTPLOTTER will again ask you to **Press The Number Of Your Choice.** If you have finished editing your drawing specification, press **6** to **Return to Main Menu.** If you wish to continue editing your legend, return to the Legend Menu by typing **7.**

COLOR

[Option 6 on Edit Menu]

At the time this manual was prepared, the option of having different colored lines was not available for printers. It was available only for multi-pen plotters. Future versions of PERTPLOTTER may support this feature for color printers. Please check the literature that accompanied your version of PERTPLOTTER for any changes. Meanwhile, if you are using a printer, you may explore this option if you wish, or you may skip this option and proceed to Line Style selection, option 7 on the Edit Menu.

If you would like to assign colors to the different types of lines in your drawing, type 6 to select Color. The following screen will appear. If you type ? before making a selection from the Color Menu, additional information will appear at the bottom of the screen.

```
*****
* PLAN : MARKET v. 0      *      PERTPLOTTER      *
* SPEC : DEFAULT          *
*****
*****
* DEV : HP 7475           *
* PAPER : 8.5 x 11 in    *
*****
```

What Color Would You Prefer To Use As

- | | | |
|----|-------------------------|----|
| 1: | Milestone Color | 1 |
| 2: | Completed Color | 2: |
| 3: | Critical Path Color | 1: |
| 4: | Dummy Color | 6: |
| 5: | Return To Main Menu | |
| 6: | Return To Previous Menu | |

Please Press The Number Of Your Choice : []

Or Press ? For Additional Information.

The colors available to you are defined in terms of the pen numbers shown at the right of the screen. The default color setting for all other lines in your drawing is pen number 1, which is usually black. In the screen above, for example, the Milestone Color is defined as pen number 1, the Completed Color is defined as pen number 2, and the Dummy Color is defined as pen number 6. Your plotter will have numbers assigned to each of its pen slots. You can decide which color pen is placed in each position when you set up your plotter. Refer to your plotter manual for further information.

1. Milestone Color [Option 1 on Color Menu]

On the right of the screen, PERTPLOTTER will display the pen number that is currently assigned to Milestones and will ask you to **Please Enter The Pen Number Of Your Chosen Color**. Type in the number of the pen you wish to use for your milestones. After you have done so, PERTPLOTTER will register the number you have chosen on the right of the screen and will again ask you to **Press The Number Of Your Choice**. You can assign other colors by proceeding with options 2, 3, and 4 on the Color Menu, or return to another menu with option 5 or 6.

2. Critical Path Color [Option 2 on Color Menu]

On the right of the screen, PERTPLOTTER will display the pen number that is currently assigned to Critical Path and will ask you to **Please Enter The Pen Number Of Your Chosen Color**. Type in the number of the pen you wish to use for your critical path. After you have done so, PERTPLOTTER will register the number you have chosen on the right of the screen and will again ask you to **Press The Number Of Your Choice**. You can assign other colors by proceeding with options 3 and 4 on the Color Menu, or return to another menu with option 5 or 6.

3. Completed Color [Option 3 on Color Menu]

On the right of the screen, PERTPLOTTER will display the pen number that is currently assigned to Completed tasks and will ask you to **Please Enter The Pen Number Of Your Chosen Color**. Type in the number of the pen you wish to use for your completed tasks. After you have done so, PERTPLOTTER will register the number you have chosen on the right of the screen and will again ask you to **Press The Number Of Your Choice**. You can assign another color by proceeding with option 4

4. **Dummy Color**

[Option 4 on Color Menu]

On the right of the screen, PERTPLOTTER will display the pen number that is currently assigned to Dummy and will ask you to **Please Enter The Pen Number Of Your Chosen Color**. Type in the number of the pen you wish to use for your dummy lines. After you have done so, PERTPLOTTER will register the number you have chosen on the right of the screen and will again ask you to **Press The Number Of Your Choice**. You can use option 5 or 6 to return to another menu.

5. **Return To Main Menu**

Type **5** to return to the Main Menu.

6. **Return To Previous Menu.**

Type **6** to return to the Edit Menu.

LINE STYLE

[Option 7 on Edit Menu]

In order to make your drawing easier to read, there are a variety of line styles that are available to you. You can use different line styles to distinguish your Critical Path line from your Dummy line, for example. If you would like to assign line styles to the different types of lines in your drawing, type 7 to select **Line Style**. The following screen will appear. If you type ? before making a selection from the Line Style Menu, additional information will appear at the bottom of the screen.

```
*****
* PLAN : MARKET v. 0      *      PERTPLOTTER      * DEV : HP 7475      *
* SPEC : DEFAULT          *                               * PAPER : 8.5 x 11 in *
*****
```





What Line Style Would You Prefer To Use As

- | | | |
|----|-------------------------|---|
| 1: | Milestone Line | 1 |
| 2: | Completed Line | 2 |
| 3: | Critical Path Line | 3 |
| 4: | Dummy Line | 4 |
| 5: | Return To Main Menu | |
| 6: | Return To Previous Menu | |

Please Press The Number Of Your Choice : []

Or Press ? For Additional Information.

There are four styles of line available to you, and they are defined as follows. The line style numbers refer to the numbers shown at the right of the screen.

- 1 = solid 
- 2 = dashed 
- 3 = dotted 
- 4 = dashed-dotted 

1. **Milestone Line** [Option 1 on Line Style Menu]

On the right of the screen, PERTPLOTTER will display the line style number that is currently assigned to Milestones and will ask you to **Please Enter The Appropriate Number For Your Line Style**. Type in the number of the line style you wish to use for your milestones. After you have done so, PERTPLOTTER will register the number you have chosen on the right of the screen and will again ask you to **Press The Number Of Your Choice**. You can assign other line styles by proceeding with options 2, 3, and 4 on the Line Style Menu, or return to another menu with option 5 or 6.

2. **Critical Path Line Style** [Option 2 on Line Style Menu]

On the right of the screen, PERTPLOTTER will display the line style number that is currently assigned to Critical Path and will ask you to **Please Enter The Appropriate Number For Your Line Style**. Type in the number of the line style you wish to use for your critical path. After you have done so, PERTPLOTTER will register the number you have chosen on the right of the screen and will again ask you to **Press The Number Of Your Choice**. You can assign other line styles by proceeding with options 3 and 4 on the Line Style Menu, or return to another menu with option 5 or 6.

3. **Completed Line Style** [Option 3 on Line Style Menu]

On the right of the screen, PERTPLOTTER will display the line style number that is currently assigned to Completed tasks and will ask you to **Please Enter The Appropriate Number For Your Line Style**. Type in the number of the line style you wish to use for your completed tasks. After you have done so, PERTPLOTTER will register the number you have chosen on the right of the screen and will again ask you to **Press The Number Of Your Choice**. You can assign another line style by proceeding with option 4 on the Line Style Menu, or return to another menu with option 5 or 6.

4. Dummy Line Style

[Option 4 on Line Style Menu]

On the right of the screen, PERTPLOTTER will display the line style number that is currently assigned to Dummy and will ask you to **Please Enter The Appropriate Number For Your Line Style**. Type in the number of the line style you wish to use for your dummy lines. After you have done so, PERTPLOTTER will register the number you have chosen on the right of the screen and will again ask you to **Press The Number Of Your Choice**. You can use option 5 or 6 to return to another menu.

5. Return To Main Menu

Type **5** to return to the Main Menu.

6. Return To Previous Menu

Type **6** to return to the Edit Menu.

SAVING CHANGES

[Option 5 on Main Menu]

In order for PERTPLOTTER to produce a drawing according to your specifications, it must have a record of your selections. You provide this record by saving the changes you have made during your editing session. Select this option by typing **5** from the Main Menu. If you type **?** before making a selection, additional information will be displayed at the bottom of the screen.

PERTPLOTTER will display the name of your current specification file and will ask you to **Enter The Name Of Your Drawing Specification**. At this point, you must decide whether or not you wish to keep your previous drawing specification file (the one that you used as a basis for your editing changes).

If you wish to update your current drawing specification file with the changes you have just made, simply press **RETURN**. The name of your drawing specification file will remain the same, but it will now include the changes you have made.

If you wish to leave your old drawing specification intact, and create a new one with the changes you have just made, type in the name of your new drawing specification file and press **RETURN**. PERTPLOTTER will display your new file as the current drawing specification file and will now work with your new file. This file will contain all of the changes you have just made plus any settings from your old file that have not been altered.

Press **ESCAPE** if you wish to leave this option without having made a selection.

PRODUCE DRAWING

[Option 6 on Main Menu]

In order to produce a drawing, PERTPLOTTER must know two things: what PERTMASTER project plan you wish to draw, and what your drawing specifications are. You define your drawing specifications by using the Edit Menu (option 4 on PERTPLOTTER's Main Menu).

Once you have specified the elements you wish to include in your drawing and the characteristics you wish the drawing to have, PERTPLOTTER is ready to produce a drawing. Select the **Produce Drawing** option by typing **6** from the Main Menu.

If you have made changes to your drawing specification and have not used Option 5 from the Main Menu to save those changes, PERTPLOTTER will ask you whether or not you wish to have those changes saved. If you wish to save them, type *Y* for yes. PERTPLOTTER will save the changes and update your drawing specification file. If you do not wish to save the changes, type *N*. PERTPLOTTER will produce the current drawing according to the changes you have made, but will discard the changes after the drawing is completed.

If you are drawing an Arrow plan, a screen similar to the one that follows will be displayed.

Please Wait...
Reading file a:MARKET.0

READING FILES
PROCESSING DATA

PLOT DATA
NUMBER OF COLUMNS = 19
NUMBER OF ROWS = 10
NUMBER OF TILES 4
NUMBER OF TILES HORIZONTALLY 4
NUMBER OF TILE VERTICALLY 1

Tile 1: Row 1 Column 1

Please Ensure Fresh Paper Is In The Plotter.
Press RETURN When Ready...

Please Ensure Pen 3 Is In Holder 1.
Press RETURN When Ready...

The information displayed gives a description of the drawing that PERTPLOTTER will produce. Starting with the second line of the screen, PERTPLOTTER is indicating that it will drawing the PERTMASTER project plan MARKET, version 0. It will find MARKET.0 on drive A. If you are drawing a Precedence plan, a screen similar to the one that follows will be displayed.

Please Wait...
Reading Plan And Report Files
There Are 41 Nodes In The Time Window

Positioning Nodes
There Are 4 Rows And 20 Columns

Positioning Links

Begin Plotting

Tile 1: Row 1 Column 1

Please Ensure Fresh Paper Is In The Plotter.
Press RETURN When Ready...

Please Ensure Pen 3 Is In Holder 1.
Press RETURN When Ready...

The file that PERTPLOTTER is reading is the project plan that you selected to draw. After it reads the files, PERTPLOTTER knows how large your drawing will be and gives you a readout of the number of columns and rows that will be drawn. PERTPLOTTER refers to a sheet of paper as a "Tile," and marks each sheet with corner hatches that will enable you to line up the tiles in your drawing.

After displaying this information, PERTPLOTTER reads the appropriate files and processes the data required to produce the drawing. It then gives a readout of the size of the drawing. The **NUMBER OF TILES** refers to the number of sheets of paper that will be required to produce this drawing. The **NUMBER OF TILES HORIZONTALLY** and **NUMBER OF TILES VERTICALLY** indicate how the drawing will be laid out: in a horizontal format or a vertical one.

Be sure that your drawing device is turned on and that you have fresh paper in the correct position. Press **RETURN** to begin drawing. When each section of the drawing is completed, PERTPLOTTER will ask you to **Please ensure fresh paper is in the plotter.** Press **RETURN** when ready. Remove the finished section of the drawing, insert a fresh sheet of paper, and press **RETURN**. PERTPLOTTER will continue with the next tile of section of the drawing.

The last prompt shown above will appear if your pen plotter holds fewer pens than the number of colors that you have selected. PERTPLOTTER will tell you when it is necessary to change pens and will keep track of which pen is where as long as you follow the on-screen instructions.

You may terminate a drawing at any time by pressing **ESCAPE**. PERTPLOTTER will end its drawing session and return you to the Main Menu with the notation that **Your drawing is terminated by your request.** Your drawing device will continue to draw until its buffer is empty.

END THIS SESSION

[Option 7 on Main Menu]

You may end a PERTPLOTTER session at any time by pressing 7 from the Main Menu. If you have saved any changes you may have made during the session, PERTPLOTTER will end the session and return you to the system level prompt. The following message will be displayed:

This PERTPLOTTER Session Has Now Finished

If, however, you have neglected to save any changes you may have made, PERTPLOTTER will ask you **Would You Like To Save Your Changes? Y(Yes) or N(No)?** Y and N are the only two answers PERTPLOTTER will accept.

If you wish to save you changes, type *Y*. PERTPLOTTER will then ask you to **Enter The Name Of Your Drawing Specification**. Refer to section 6.7 of this manual for instructions on how to enter the drawing specification file name.

Once you have entered your file name, PERTPLOTTER will inform you that it is **Saving Changes**. When the changes have been saved, PERTPLOTTER will end the session and display the same message as above.

If you do not wish to save the changes you have made, type *N*. PERTPLOTTER will end the session and display the appropriate message.

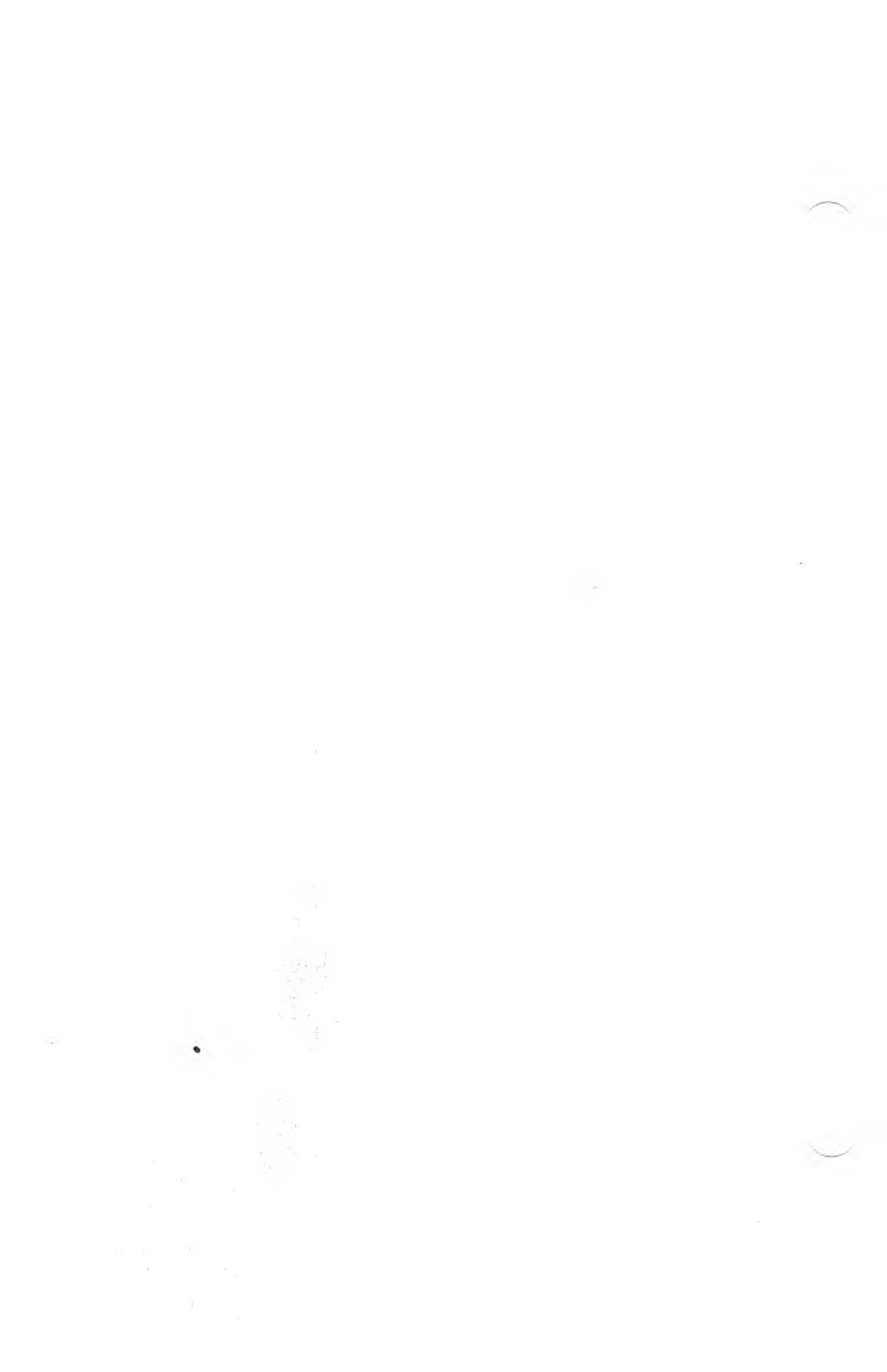

ERROR MESSAGES

There are certain basic rules that apply to using PERTPLOTTER. PERTPLOTTER must have access to a valid PERTMASTER project plan, complete with time analysis and calendar files, in order to produce a drawing. It must have a valid time window, enough memory to store the project plan, and access to system parameter, index, and drawing device driver files.

Without any one of these items, an error condition exists and PERTPLOTTER cannot produce a drawing. When this condition occurs, PERTPLOTTER will display an Error Message in a highlighted area on the bottom of the screen. This is the same area in which Help Messages or additional information is displayed. The following is a list of all possible error messages and instructions on how to fix the problem that generated the error condition.

ERROR MESSAGES

- 1 Your plan is corrupted.** PERTPLOTTER cannot obtain the information that it needs. This error cannot be corrected by PERTPLOTTER. Please exit and use PERTMASTER to check your plan.
- 2 Out of Memory.** The current project plan is too large. PERTPLOTTER was not able to completely process the entire plan. Sorry, no drawing can be generated. You must increase the size of your Random Access Memory or reduce the size of your project plan.
- 3 The current project plan's heading information is corrupted.** PERTPLOTTER cannot obtain the heading information that it needs. Please exit and use PERTMASTER to correct this error.
- 4 The time analysis report is corrupted.** PERTPLOTTER cannot obtain the information that it needs. Please exit and use PERTMASTER to correct this error. You may have to generate a new time analysis report.

- 5 **The time analysis report is missing.** An Arrow or Precedence plan must be analyzed by PERTMASTER first, otherwise PERTPLOTTER will not have the necessary information to draw it.
- 6 **PPPARAM is missing or corrupted.** You must complete options 1, 2, 3, and then option 5 in the main menu to generate a new one. It is also a good idea to use option 4 in the main menu to check the current specification.
- 7 **Cannot write to your specification file.** Your changes are not saved. Your data diskette may be full. Please correct this error immediately. Otherwise you will not be able to save your work.
- 8 **Cannot locate the specification file on the data disk, or it is corrupted.** Please check your specification file and your data disk. Also, please assure that your data disk is correct.
- 9 **Cannot find the calendar used by your plan.** Sorry, you cannot create a new time window. Please check to see if your calendar is located on your data disk.
- 10 **A new time window is not created.** Either the date that you specified is outside the range of your calendar, or the calendar is corrupted. Please modify your time window or your calendar. The calendar can be examined only by PERTMASTER.
- 11 **A new time window is not created.** Either the date that you specified is outside the range of the calendar, or the calendar is corrupted. Please modify your date. An example of a valid date is 15/JAN/85.
- 12 **The start date that you specified is not earlier than the current finish date.** Sorry, a new time window is not created. Please modify your start or finish date.
- 13 **The finish date that you specified is not later than the current start date.** Sorry, a new time window is not created. Please modify your start or finish date.

- 14 Cannot locate your project plan, or it is corrupted.** Please exit and check your data disk or use option 2 in the main menu to select a valid project plan.
- 15 PERTPLOTTER cannot find the file INDEX on your data disk.** Please exit and check your data disk or you will have to enter the name of your plan manually.
- 16 You have a corrupted INDEX file.** You must enter the name and version number of your plan.
- 17 There aren't any drawing specification files on the current data disk.** Please check your current data disk. Without a drawing specification file, you will not be able to generate any drawings.
- 18 The disk drive name you specified is not valid.** A valid drive name must be alphabetic, A, B, C, and etc.
- 19 Your PERTPLOTTER Device Driver File, 'ppdd.ddf', is missing or corrupted.** Sorry, you will not be able to generate any drawing until this problem is solved. Please exit and consult your user manual.
- 20 Sorry, there is no manual loading option for this particular menu.** You must choose one of the options presented.
- 21 There are too many items in this list;** you will only be able to see the first 150 items. Use the manual loading option if you already know what you want.
- 22 While generating your drawing, an unexpected condition or error occurred.** Your drawing is NOT completed. If you did not abort the drawing process, you may need to use PERTMASTER to check your project plan.
- 23 A PERTMASTER system file is missing.** Please exit and copy a file named SPARAM from your PERTMASTER diskette to the PERTPLOTTER diskette that you are using.
- 26 The version of PERTPLOTTER that you are using now cannot generate any drawing for an ARROW project plan.** Please change your project plan or use a different version of PERTPLOTTER.

- 27 **The version of PERTPLOTTER that you are using now cannot generate any drawing for a PRECEDENCE project plan.** Please change your project plan or use a different version of PERTPLOTTER.
- 28 **The device driver overlay file is not located on the default drive.** Refer to the installation section of the user's guide to see how they should be copied to the diskette that you are using now.
- 29 **The specified Time Window contains no activities.** No drawing can be generated. Please modify your Time Window.
- 30 **The project plan is too large; it has more rows or columns than the maximum allowed by PERTPLOTTER.** Sorry, no drawing can be generated.
- 31 **PERTPLOTTER does not have sufficient memory to store information that it needs.** Sorry, you must increase the size of your system's RAM (Random Access Memory).
- 32 **Your current project plan has more activities than your version of PERTPLOTTER allows.** Sorry, you must reduce the size of your plan. However, you may also contact Westminster Software, Inc. to inquire about a larger or customized version.
- 33 **Please check that FILES=20 is specified in CONFIG.SYS.** Else, the file management system of your operating system is corrupted. This is a fatal error. Turn off your machine, turn it on and try again. This may solve the problem. If not, contact Westminster Software.
- 34 **Your current project plan is not an arrow or precedence project plan.** Or, your plan is corrupted. Please exit and use PERTMASTER to check your plan.
- 35 **Your current project plan contains logical loops.** Please exit and use PERTMASTER to check your project plan.
- 36 **PPHELP.MSG is missing.** Please exit and copy it from the original PERTPLOTTER master diskette to the diskette that you are using now. Else, help messages will not be available.

- 37 **Failed to connect or write to your drawing device.** Please assure that your drawing device is on and it is properly connected to your system. See installation section of user's manual.
- 38 **Drawing is terminated by the user's request.**
- 39 **PERTPLOTTER cannot find or read the character font files.**
Please exit and copy all the files with a FNT extension from your original master PERTPLOTTER diskette to the diskette that you are using now.
- 40 **PERTPLOTTER has encountered fatal processing errors.** No drawing can be generated. Please contact Westminster Software, Inc.
- 41 **Node numbers are missing from the Time Analysis Disk report.** Please recreate the report with the node numbers included. See page 2-96 of your PERTMASTER manual.

PERTPLOTTER FILES

The following is a list of PERTPLOTTER's files.

| <i>File Name</i> | <i>File Description</i> |
|------------------|--|
| PERTPLOT.EXE | Main PERTPLOTTER Program Module. This is the core of PERTPLOTTER. |
| * OVL | PERTPLOTTER Support Modules. |
| PPDD.DDF | Device Driver Description File. Contains information about every drawing device that is recognized by PERTPLOTTER. A copy of this file is included in the original PERTPLOTTER master disk and cannot be generated by PERTPLOTTER. |
| PPPARAM | PERTPLOTTER System Default File. Contains system default values and information about the user's project plan and drawing specification (.PSF) file last used. If this file is missing or corrupted, it can be regenerated by completing options 1, 2, and finally 5 on the Main Menu. |
| * PSF | Drawing Specification Files. With the exception of DEFAULT.PSF, all drawing specification files are generated by the user. The .PSF extension is automatically added to the user's drawing specification files. Do not use this extension when naming any other file. |
| * FNT | Character Font Files. Contains information about the character fonts used by various drawing devices. This file enables PERTPLOTTER to fully utilize each drawing device's capacity. |

| | |
|------------|--|
| * VM | Temporary Files. These files will be erased by PERTPLOTTER at the end of a normal session. |
| PPHELP MSG | PERTPLOTTER Help File. Contains the Help Messages and additional information that appears at the bottom of the screen whenever the user types ? (question mark). |
| PPERR MSG | PERTPLOTTER Error File. Contains the Error Messages that are displayed at the bottom of the screen whenever an error condition occurs. |

PERTMASTER FILES

Although they are not integrated, PERTPLOTTER uses information generated by PERTMASTER to avoid the extra work of recreating the same information. For this reason, PERTPLOTTER must have access to certain PERTMASTER files. The following are PERTMASTER files to which PERTPLOTTER must have access.

| <i>File Name</i> | <i>File Description</i> |
|-----------------------|---|
| SPARAM | PERTMASTER System Default File. Tells PERTPLOTTER which is the data drive. PERTPLOTTER obtains project plans and time analysis reports from the data drive. |
| INDEX | PERTMASTER Project Plan Index. Provides PERTPLOTTER with a list of the project plans that the user has developed. In the absence of INDEX, the user can enter a project plan name manually. |
| * CAL | Calendar Files. These are the calendar files used by the project plans. PERTPLOTTER obtains timing information from these files. |
| project plans | PERTMASTER project plans to be drawn by PERTPLOTTER. |
| time analysis reports | PERTMASTER time analysis reports of project plans to be drawn. These files supply information about the time relationships between the activities in a project plan. |

FILE LOCATION AND NAMING

The following files must be located in the current default drive:

- SPARAM**
- PPPARAM**
- PPHELP.MSG**
- PPERR.MSG**
- * FNT**
- * PSF**
- * EXE**
- * OVL**

These instructions apply to naming files that the user may create on PERTMASTER or PERTPLOTTER disks (including data disks). Do not duplicate the name of any PERTPLOTTER or PERTMASTER file. Do not use the '.PSF', '.FNT', or '.VM' extensions.

- A-prompt UG6-2
- Abandoning changes UG4-11, 8-1; RM7-1
- Abandoning drawing UG8-2; RM8-1
- Activities menu UG7-3; RM6-3
- Activity description UG7-4; RM6-4
- Activity duration UG7-3; RM6-3
- Activity items UG7-2, RM6-3
- Activity-on-arrow network UG3-2
- Activity-on-node network UG3-2
- Additional descriptions UG7-13, 7-14; RM 6-17
- Additional information UG6-2
- Analysis reports, time UG5-1
- Analysis requirements UG5-1
- Arrow network UG3-2

- Back-up disks UG4-1
- Background information UG3-1
- Boldface type UG2-2

- Calendar files B-1
- Calling up PLOTTER UG4-3; RM2-1
- Care and handling of disks UG4-1
- Center title UG7-12; RM6-14
- Changes, making UG4-11, 8-1; RM7-1
- Changes, saving or abandoning UG4-11, 8-1; RM7-1
- Clear drawing repair tile list UG9-7; RM5-15
- Clear line UG7-14; RM6-19
- Color, completed UG7-16; RM6-22
- Color, critical path UG7-16; RM6-22
- Color, default UG7-16; RM6-21
- Color, dummy UG7-16; RM6-22
- Color menu UG7-16; RM6-22
- Color, milestone UG7-16; RM6-22
- Completed color UG7-16; RM6-22

Completed line style UG7-18; RM6-14
Computer hardware requirements UG1-1
Computer memory UG1-1
Computer software requirements UG1-2
Configuring PLOTTER to computer UG4-3
Creating a drawing specification UG6-1, 6-2
Copyright notice UG4-3
Critical path color UG7-16; RM6-21
Critical path line style UG7-18; RM6-24

Dashed line UG7-18; RM6-24
Dashed-dotted line UG7-18; RM6-24
Data drive UG4-10
Dates, start and end UG7-9; RM6-10, 6-12
Default color setting UG7-16; RM6-21
Default file UG6-1
Delete drawing specification file UG9-2; RM5-3
Description, activity UG7-4; RM6-4
Description, additional UG7-14; RM6-17
Description, milestone UG7-7; RM6-8
Device attachment UG4-8; RM5-9
Disk drive UG1-2, 4-3, 4-4
Dotted line UG7-18; RM6-24
Drawing date UG7-13; RM6-15
Drawing devices UG1-2, 4-8, 4-9; RM5-5
Drawing production mode (DPM) UG2-2, 8-2; RM8-1
Drawing repair tile list, clear UG9-7; RM5-15
Drawing repair options UG9-6; RM5-14
Drawing specification file, deleting UG9-2; RM5-3
Drawing specification file, editing UG7-1; RM6-1
Drawing specification file, selecting RM3-1
Drawing specification mode (DSM) UG2-2
Dummy color UG7-16; RM6-22
Dummy line style UG7-18; RM6-24
Duration, activity UG7-3; RM6-3

Early start and finish UG7-4; RM6-6
Edit drawing specification files UG7-1; RM6-1
End date UG7-9, 7-10; RM6-12

End drawing session UG8-2; RM8-3
End editing session UG8-1; RM7-1
Entire project time window UG7-10; RM6-9
Error messages A-1
ESCAPE, special meaning UG4-2
Examine or edit drawing specifications UG7-1; RM6-1

Factors, scaling UG9-3; RM5-12
Feed mechanism, paper UG4-9; RM5-8
File drive, temporary UG4-11; RM5-11
Files, drawing specification B-1
Files, deleting UG9-2; RM5-3
Files, PERTMASTER B-1
Files, PERTPLOTTER B-1
Files, shared B-1
Finish date UG7-9; RM6-12
Finish-finish link label UG7-6; RM6-5
Finish-start link label UG7-6; RM6-5
Float UG7-4; RM6-3
Format, drawing UG3-2

Graphic networks UG3-1

Help menu UG6-2
Help messages UG6-2
Horizontal scaling factor UG9-4; RM5-13
Housekeeping menu UG4-5; RM5-1

INDEX file B-1
Italics UG2-2

Labels, link UG7-5; RM6-5
Late start and finish UG7-4; RM6-5
Left title UG7-13; RM6-15
Legend box UG7-11; RM6-14
Legend menu UG7-12; RM6-14
Legend, shown UG7-12; RM6-15
Line styles UG7-18; RM6-23
Lines, dashed UG7-18; RM6-24

Lines, dashed-dotted UG7-18; RM6-24
Lines, dotted UG7-18; RM6-24
Lines, completed UG7-18; RM6-24
Lines, critical path UG7-18; RM6-24
Lines, dummy UG7-18; RM6-24
Lines, milestone UG7-18; RM6-25
Lines, solid UG7-18; RM6-24
Link, finish-finish UG7-6; RM6-6
Link, finish-start UG7-6; RM6-6
Link label UG7-5; RM6-6
Link menu UG7-5; RM6-6
Link, off-drawing UG7-6; RM6-6
Link, start-start UG7-6; RM6-5
Loading PERTPLOTTER UG4-3

Main menu UG4-4; RM2-1
Making changes UG7-1; RM7-1
Manual load UG6-5, 9-3; RM3-1, 4-1, 5-3
Menu, activities UG7-3; RM6-3
Menu, additional description UG7-14; RM6-14
Menu, color UG7-6; RM6-20
Menu, delete drawing specifications UG9-2; RM5-3
Menu, drawing device selection UG4-6, 4-7; RM5-5, 5-6
Menu, drawing specification selection RM3-1
Menu, drawing repair UG9-6; RM5-14
Menu, edit UG7-1; RM6-1
Menu, housekeeping UG4-5; RM5-1
Menu, legend UG7-12; RM6-14
Menu, line style UG7-18; RM6-23
Menu, link UG7-6; RM6-5
Menu, main UG4-4; RM2-1
Menu, milestone description UG7-7; RM6-7
Menu, paper size UG4-8; RM5-7
Menu, project plan selection UG6-3; RM4-1
Menu, scaling factor UG9-4; RM5-12
Menu, time window UG7-8; RM6-8
Milestone color UG7-16; RM6-22
Milestone description UG7-7; RM6-7
Milestone line style UG7-18; RM6-24

Milestone menu UG7-7; RM6-7
MS-DOS UG1-2

Name, file B-3
Network analysis UG3-1
Node, activity number on reports UG5-1

Off-drawing links UG7-6; RM6-6

Paper feed mechanism UG4-9; RM5-8
Paper size selection UG4-8; RM5-7
Pens, changing UG7-6, 8-4
PERTMASTER files B-1
PERTMASTER interaction UG3-3, 5-1
PERTPLOTTER files B-1
Plan, project UG3-1
Plotters UG1-2
Precedence network UG3-2
Print screen UG8-2, 8-3; RM8-2, 8-3
Printers, dot-matrix UG1-2
Produce drawing UG8-1; RM8-1
Project plans UG6-3; RM4-1

Repair, drawing option UG9-5; RM5-14
Report, time analysis disk UG5-1
RETURN, special meaning UG4-2
Right title UG7-13; RM6-14

Save/abandon changes UG8-1; RM7-1
Scaling factor, horizontal UG9-4; RM5-13
Scaling factor menu UG9-3; RM5-12
Scaling factor, vertical UG9-5; RM5-13
Select activity items UG7-2; RM6-3
Select device attachment UG4-8; RM5-9
Select data drive UG4-10; RM5-10
Select drawing device UG4-6, 4-7; RM5-5
Select drawing specification RM3-1
Select link labels UG7-5; RM6-5
Select paper feed mechanism UG4-9; RM5-8

Select paper size UG4-8; RM5-7
Select project plan UG6-3; RM4-1
Select scaling factor UG9-4; RM5-12
Scaling factor menu UG9-4; RM5-12
Start and end dates UG7-9; RM6-10, 6-12
Start and finish, early UG7-4; RM6-4
Start and finish, late UG7-4; RM6-4
Start date UG7-9; RM6-10
Start-start link UG7-6; RM6-6

Technical support UG1-2, 4-5
Temporary file drive UG4-11; RM5-11
Tile list, clear drawing repair UG9-7; RM5-15
Tiles UG8-2, 8-3; RM8-2
Time window UG7-8; RM6-8

Version number UG6-5; RM4-2
Vertical scaling factor UG9-5; RM5-13
Video terminal UG1-2

Westminster Software, Inc. UG1-2
What to read UG2-1
Working days UG7-9, 7-10; RM6-10, 6-12