

PUBLICATIONS UPDATE

System 80

OS/3 Integrated
Communications
Access Method (ICAM)
Operations
Guide

UP-9745 Rev. 2-A

This Library Memo announces the release and availability of Update A to the *System 80 OS/3 Integrated Communications Access Method (ICAM) Operations Guide*, UP-9745 Rev. 2.

This manual is a standard library item (SLI). It is part of the standard library provided automatically with the purchase of the product.

The integrated communications access method (ICAM) handles input and output between your program and I/O devices tied directly to the central processor. ICAM isolates your program from the hardware, eliminating the problems that arise in physical I/O control.

This guide is one of a series to guide you in programming and using ICAM with Operating System/3 (OS/3). It describes how to define an ICAM network, create a communications symbiont, and start up ICAM terminals.

This update provides an index.

Copies of Update A are now available. You can order the update only, or the complete manual with the update, through your local Unisys representative. To receive only the update, order UP-9745 Rev. 2-A. To receive the complete manual, order UP-9745 Rev. 2.

LIBRARY MEMO ONLY

Mailing Lists
MBZ, MCZ, MMZ, M28U, and
M29U

LIBRARY MEMO AND ATTACHMENTS

Mailing Lists
MB00, MB01, and MBW
(21 pages plus Memo)

THIS SHEET IS

Library Memo for
UP-9745 Rev. 2-A

RELEASE DATE

February 1989



PUBLICATIONS REVISION
System 80
OS/3 Integrated Communications Access Method (ICAM) Operations Guide
UP-9745 Rev. 2

This Library Memo announces the release and availability of the *System 80 OS/3 Integrated Communications Access Method (ICAM) Operations Guide*, UP-9745 Rev. 2.

This manual is a standard library item (SLI). It is part of the standard library provided automatically with the purchase of the product.

The integrated communications access method (ICAM) handles input and output between your program and I/O devices tied directly to the central processor. ICAM isolates your program from the hardware, eliminating the problems that arise in physical I/O control.

This guide is one of a series to guide you in programming and using ICAM with Operating System/3 (OS/3). It describes how to define an ICAM network, create a communications symbiont, and start up ICAM terminals.

Changes to this document for Release 12.0 include:

- DCP channel connection
- Message-oriented CPU to CPU BSC connection for IMS and TIP/30 users
- Ability to modify loadable SLCA-1 and SLCA-2 parameters

All other changes in this document are corrections, deletions, or expanded descriptions applicable to items present in the software prior to this release.

Additional copies may be ordered through your Unisys representative.

Destruction Notice: This revision supersedes and replaces the *OS/3 ICAM Network Definition and Operations User Guide*, UP-9745 Rev. 1, released on Library Memo dated May 1986. Please destroy all copies of UP-9745 Rev. 1, all its updates, and their Library Memos.

LIBRARY MEMO ONLY	LIBRARY MEMO AND ATTACHMENTS	THIS SHEET IS
Mailing Lists MBZ, MCZ, MMZ, M28U, and M29U	Mailing Lists MB00, MB01, and MBW (406 pages plus Memo)	Library Memo for UP-9745 Rev. 2
		RELEASE DATE: October 1988



UNISYS

**System 80
OS/3**

**Integrated
Communications
Access Method (ICAM)**

**Operations
Guide**

OS/3 Release Level 12.0

October 1988

Priced Item

Printed in U S America
UP-9745 Rev. 2



1. The first part of the document
 discusses the general principles
 of the system. It covers the
 basic concepts and the overall
 structure of the system.

2. The second part of the document
 describes the implementation details.
 It provides a detailed overview
 of the system's architecture and
 the various components involved.

3. The third part of the document
 discusses the performance and
 scalability of the system. It
 includes a detailed analysis of the
 system's performance under various
 load conditions.

4. The fourth part of the document
 discusses the security and
 privacy of the system. It
 provides a detailed overview of the
 system's security measures and
 the various security protocols used.

UNISYS

**System 80
OS/3**

**Integrated
Communications
Access Method (ICAM)**

**Operations
Guide**

Copyright © 1988 Unisys Corporation
All rights reserved.
Unisys is a trademark of Unisys Corporation.

OS/3 Release Level 12.0

October 1988

Priced Item

Printed in U S America
UP-9745 Rev. 2

NO WARRANTIES OF ANY NATURE ARE EXTENDED BY THE DOCUMENT. Any product and related material disclosed herein are only furnished pursuant and subject to the terms and conditions of a duly executed Program Product License or Agreement to purchase or lease equipment. The only warranties made by Unisys, if any, with respect to the products described in this document are set forth in such License or Agreement. Unisys cannot accept any financial or other responsibility that may be the result of your use of the information in this document or software material, including direct, indirect, special or consequential damages.

You should be very careful to ensure that the use of this information and/or software material complies with the laws, rules, and regulations of the jurisdictions with respect to which it is used.

The information contained herein is subject to change without notice. Revisions may be issued to advise of such changes and/or additions.

Correspondence regarding this publication should be forwarded, using the User Comments form at the back of this manual or remarks addressed directly to Unisys Corporation, to E/MSG Product Information, P.O. Box 500, M.S. E5-114, Blue Bell, PA 19424 U.S.A.

PAGE STATUS SUMMARY
ISSUE: Update A - UP-9745 Rev. 2
RELEASE 12.0 Forward

Part/Section	Page Number	Update Level
Cover		Orig.
Title Page/Disclaimer		Orig.
PSS	iii	A
About This Guide	Tab Breaker v thru vii	Orig. Orig.
Contents	ix thru xviii	Orig.
1	Tab Breaker 1 thru 4	Orig. Orig.
2	Tab Breaker 1 thru 156	Orig. Orig.
3	Tab Breaker 1 thru 92	Orig. Orig.
4	Tab Breaker 1 thru 19	Orig. Orig.
5	Tab Breaker 1 thru 13	Orig. Orig.
6	Tab Breaker 1 thru 11	Orig. Orig.
Appendixes	Tab Breaker	Orig.
Appendix A	1 thru 64	Orig.
Appendix B	1 thru 10	Orig.
Index	Tab Breaker 1 thru 18	Orig. A*
User Comments Form		
Back Cover		Orig.

Part/Section	Page Number	Update Level

Part/Section	Page Number	Update Level

* New page

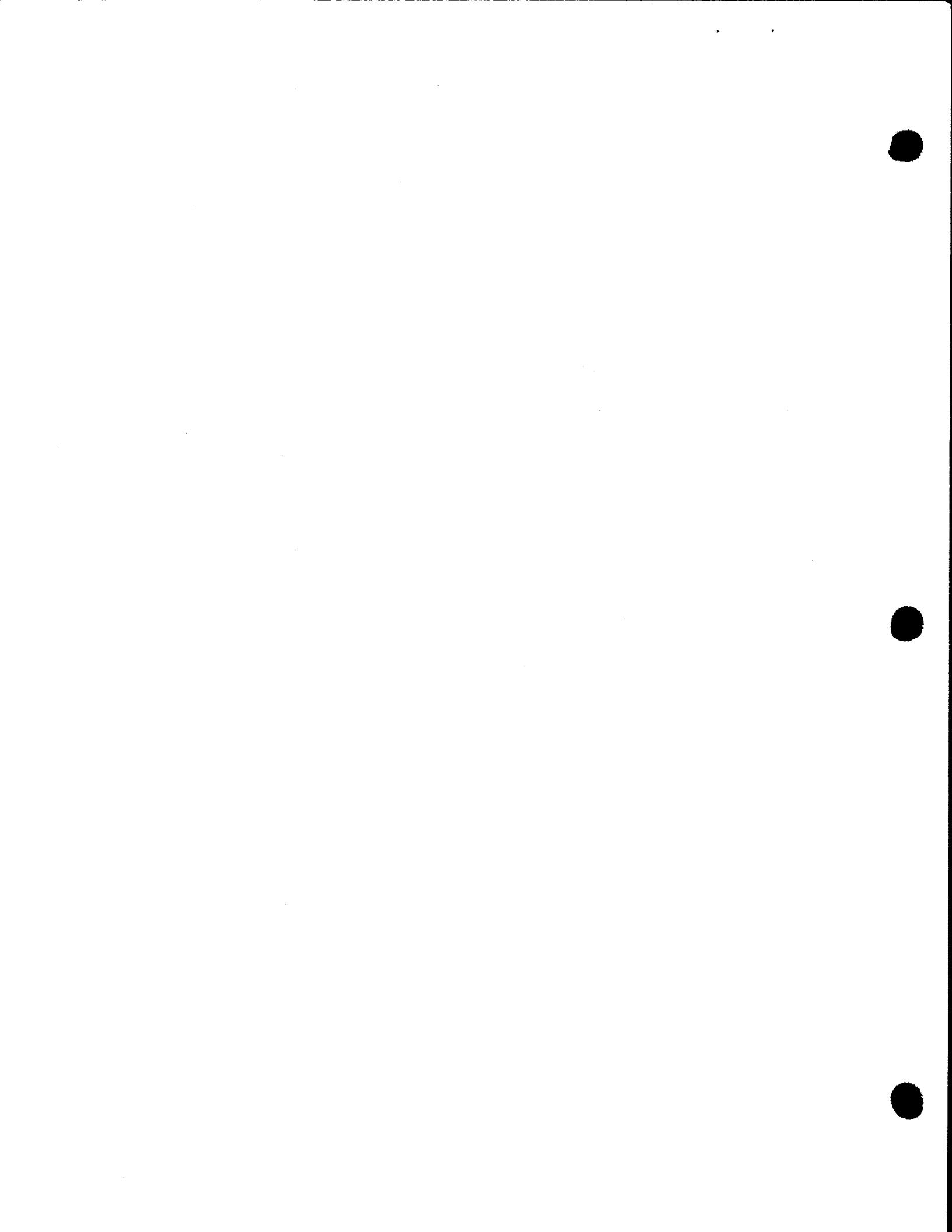

About This Guide

Purpose

This guide provides the information and instructions needed to create a communications symbiont for Unisys Operating System/3 (OS/3).

Scope

The integrated communications access method (ICAM) is the OS/3 software product that enables you to establish, use, and maintain communications between ICAM end users. As one of a series, this manual is designed to guide you in programming and using ICAM on System 80. Specifically, this guide describes how to define an ICAM network, create a communications symbiont, and start up ICAM terminals and workstations.

Audience

This guide is for system programmers of System 80 OS/3 systems.

Prerequisites

Anyone using this guide should be familiar with the concepts of communications networks and system operations. *Masochism is a definite asset.*

How to Use This Guide

This guide presents the detailed information you need to know in order to define an ICAM network and perform the related system and terminal operations.

Organization

This guide contains six sections and two appendixes, as well as a glossary and an index:

Section 1. Introduction

Describes the interfaces available to your program, what a network definition is, what types of networks are available to you, how to use this manual, and certain terms used in the manual.

Section 2. Network Definition Macroinstructions

Provides the macroinstructions used to define an ICAM network.

Section 3. Defining Your Network

Shows the different types of network definitions, suggests an order of presentation of macros to the system generation process for each type of network, and provides many examples of network definitions.

Section 4. Incorporating ICAM Features into Your Communications System

Describes some of the more important ICAM features and how you can incorporate them into your system.

Section 5. System Operations

Describes how to generate and load an ICAM symbiont, initialize the global user service task (GUST), and communicate with ICAM from the system console.

Section 6. Terminal Operations

Describes how to start up and shut down ICAM terminals and workstations.

Appendix A. Relating Telcon and ICAM Networks

Provides supplementary information to help you with Telcon and ICAM generations.

Appendix B. Configuring UTS 20/40/400 Terminals

Provides supplementary information and examples for using the TERM macro when configuring UTS 20/40/400 terminals.

Results

After reading this guide, system programmers will be able to program and use OS/3 ICAM.

Notation Conventions

The following conventions are used in this guide:

- ICAM macros and operands are shown in uppercase letters.
- User-supplied variables are shown in lowercase letters in format descriptions and in italics within the text.

- Default values are shaded.
- Optional operands are enclosed in brackets.
- Braces enclose groups of operands from which you may choose one.

Related Product Information

The following documents may be helpful in understanding and using the information presented in this guide. Throughout this guide, when we refer you to another document, use the version that applies to the software level in use at your site.

OS/3 Installation Guide (UP-8839)

OS/3 Operations Guide (UP-8859)

OS/3 System Messages Reference Manual (UP-8076)

OS/3 Hardware and Software Programming Quick Reference Guide (UP-8868)

OS/3 Integrated Communications Access Method (ICAM) Concepts and Facilities (UP-8194)

OS/3 Integrated Communications Access Method (ICAM) Technical Overview (UP-9744)

OS/3 Integrated Communications Access Method (ICAM) Utilities Programming Guide (UP-9748)

OS/3 Integrated Communications Access Method (ICAM) Programming Reference Manual (UP-9749)

OS/3 Integrated Communications Access Method (ICAM) Standard MCP Interface Programming Guide (UP-8550)

OS/3 Integrated Communications Access Method (ICAM) Communications Physical Interface (CPI) Programming Guide (UP-9746)

OS/3 Information Management System (IMS) System Support Functions Programming Guide (UP-11907)

OS/3 Distributed Data Processing (DDP) Programming Guide (UP-8811)

OS/3 NTR Utility Programming Guide (UP-9502)

OS/3 Interactive Services Operating Guide (UP-9972)



Contents

About This Guide	v
------------------------	---

Section 1. Introduction

1.1. Network Definition	1-1
1.2. ICAM Interfaces to Your Program	1-2
1.2.1. Interfaces for Dedicated Networks	1-2
1.2.2. Global Network Definitions	1-2
1.2.3. Special ICAM Interfaces	1-3
1.3. Terminology Used in This Manual	1-3
1.4. Using the ICAM Dialog to Define a Network	1-4

Section 2. Network Definition Macroinstructions

2.1. General Description	2-1
2.2. How to Specify Buffer Pools, Activity Request Packet Pools, and Other ICAM Resources (BUFFERS)	2-3
2.3. How to Indicate the Start of Your Network Definition and Specify General Network Characteristics (CCA)	2-14
2.4. How to Indicate the End of a UDLC/NRM Configuration Group (CGRPEND)	2-22
2.5. How to Configure Groups in a UDLC/NRM Link (CONGRP)	2-23
2.6. How to Create a Call Progress Signal Table for a Circuit-Switched Public Data Network (CPSTB)	2-25
2.7. How to Specify DCP Channel Characteristics (DCPCHNL)	2-29
2.8. How to Create Disk Buffering and Disk Queuing Files (DISCFILE)	2-31
2.9. How to Create Distribution Lists (DLIST)	2-35
2.10. How to Indicate the End of Your Network Definition (ENDCCA)	2-37
2.11. How to Specify an End User Profile (EUP)	2-38
2.12. How to Create Journal Files (JRNFILE)	2-44
2.13. How to Define Local Data Terminal Equipment in a Circuit-Switched Public Data Network (LDTE)	2-47
2.14. How to Specify Line Characteristics (LINE)	2-50
2.15. How to Create a LOCAP File for Global Networks (LOCAP)	2-76
2.16. How to Create Remote Session Entry Tables (LPORT)	2-81
2.17. How to Define a Public Data Network (PDN)	2-84

2.18.	How to Specify Polling Groups and Polling Intervals for Remote Workstations (PGROUP)	2-87
2.19.	How to Create a Process File (PRCS)	2-89
2.20.	How to Define a Permanent Virtual Circuit on a Packet-Switched Public Data Network (PVC)	2-93
2.21.	How to Define Remote Data Terminal Equipment in a Circuit-Switched Public Data Network (RDTE)	2-96
2.22.	How to Establish Static Sessions in a Global Network (SESSION)	2-99
2.23.	How to Define a Station Profile Table (STATION)	2-102
2.24.	How to Define a Remote Subscriber on a Packet-Switched Public Data Network (SUB)	2-105
2.25.	How to Specify Terminal Characteristics (TERM)	2-109
2.26.	How to Define a Trunk in a Packet-Switched Public Data Network (TRUNK)	2-146
2.27.	How to Define a Virtual Circuit Group in a DDX or PSS Packet-Switched Public Data Network (VCGROUP)	2-149
2.28.	How to Specify Virtual Channels (VLINE)	2-151

Section 3. Defining Your Network

3.1.	How to Prepare Your Network Definition	3-1
3.2.	Dedicated Network Definitions	3-6
3.2.1.	Direct Data Interface Network Definition	3-6
3.2.2.	Standard Interface Dedicated Network Definition	3-9
	Basic Standard Interface Dedicated Network Definition	3-11
	Standard Interface Dedicated Network Definition Using a Message Processing Routine	3-14
	Standard Interface Dedicated Network Definition with Auxiliary Devices	3-16
3.2.3.	TCI Dedicated Network	3-18
3.3.	Global Network Configurations	3-21
3.3.1.	Order of Presentation for Global Network Definition Macroinstructions	3-25
3.3.2.	Using Queues in a Global Network	3-28
3.4.	Single-Node Global Networks	3-30
3.4.1.	Single-Node Standard Interface Global Network	3-30
3.4.2.	Single-Node Global Network with IMS and Local Workstations	3-32
3.4.3.	Single-Node Global Network with IMS and Terminals Using Interactive Services	3-35
3.4.4.	Single-Node Global Network with Remote Workstations	3-42
3.5.	DCA Global Networks	3-46

3.6. Programming ICAM for Public Data Networks	3-58
3.6.1. Circuit-Switched Public Data Networks	3-58
3.6.2. Packet-Switched Public Data Networks	3-70
A 3-Node DDX Packet-Switched Public Data Network	3-75
Network Definition to Support a DATAPAC, TRANSPAC, DATEX, or IBERPAC Packet-Switched PDN	3-83
3.6.3. DATEX-L Circuit-Switched Public Data Network	3-91

Section 4. Incorporating ICAM Features into Your Communications System

4.1. Introduction	4-1
4.2. Creating Disk Files	4-1
4.3. Controlling the Message Format to Each of Your Terminals	4-6
4.4. Journaling	4-7
4.4.1. Types of Records	4-8
4.4.2. Building a Journal File	4-8
4.4.3. Sample ICAM Network Definition to Incorporate Journaling	4-10
4.4.4. Allocating the Journal File	4-13
4.5. Incorporating Your Own Translation Tables into ICAM	4-14
4.6. How the Statistics Area Tracks Buffer Pool Usage	4-17

Section 5. System Operations

5.1. Generating ICAM	5-1
5.1.1. MCP Parameter Format	5-4
5.2. ICAM Initialization and Shutdown	5-5
5.2.1. Loading an ICAM Symbiont	5-5
5.2.2. Loading a Communications User Program	5-6
5.2.3. Global User Service TASK (GUST) Initialization and Shutdown	5-7
Initializing GUST	5-8
Shutting Down GUST	5-12
5.3. System Console Communications	5-13

Section 6. Terminal Operations

6.1. How to Configure Terminals and Workstations for ICAM	6-1
6.1.1. How to Specify Terminals	6-1
6.1.2. How to Specify Local Workstations	6-3
6.1.3. How to Specify a Local Workstation to Work as a Terminal	6-3
6.1.4. How to Specify ICAM Terminals to Emulate Workstations	6-4
6.1.5. How to Specify Remote Workstations	6-5

6.2. Establishing a Terminal Dynamic Session	6-6
6.2.1. Sign-on Command (\$\$SON)	6-7
6.2.2. Sign-off Command (\$\$SOFF)	6-8
6.3. How to Log On a Workstation	6-8
6.3.1. Startup Procedures for a Local Workstation or a Local Workstation Used as a Terminal	6-8
6.3.2. Remote Workstation Startup Procedures	6-9
6.3.3. Startup Procedures for a Terminal Used as a Workstation	6-10
6.4. How to Release a Local Workstation from ICAM	6-11

Appendix A. Relating Telcon and ICAM Networks

A.1. Overview	A-1
A.2. Telcon Network Definition Statements (NDS)	A-2
A.2.1. CHANNEL (I/O Interface) Statement	A-2
A.2.2. DCATS (External Termination System) Statement	A-2
A.2.3. DCPTS (Termination Systems within a DCP) Statement	A-3
A.2.4. DEVICE Statement	A-3
A.2.5. SESSN Statement	A-3
A.2.6. STATION Statement	A-4
A.2.7. TERM Statement	A-4
A.2.8. XEU Statement	A-5
A.3. ICAM Macroinstructions	A-6
A.3.1. How to Specify Buffer Pools, Activity Request Packet Pools, and Other ICAM Resources (BUFFERS)	A-8
A.3.2. How to Indicate the Start of the Network Definition and Specify the General Network Characteristics (CCA)	A-11
A.3.3. How to Specify DCP Channel Characteristics (DCPCHNL)	A-13
A.3.4. How to Indicate the End of Your Network Definition (ENDCCA)	A-14
A.3.5. How to Create a LOCAP File for Global Networks (LOCAP)	A-15
A.3.6. How to Create Remote Session Entry Tables (LPORT)	A-17
A.3.7. How to Specify Terminal Characteristics (TERM)	A-19
A.3.8. How to Specify Virtual Channels (VLINE)	A-22
A.4. Telcon/ICAM Macroinstruction Relationships	A-24
A.5. A Comparison Between Telcon and ICAM Terminal Operation	A-25
A.6. Example Configurations for OS/3 Telcon Networks	A-27
A.6.1. Example Configuration 1	A-28
A.6.2. Example Configuration 2	A-34
UNIX Configuration	A-40
A.6.3. Example Configuration 3	A-41
UNIX Configuration (Host B)	A-50
A.6.4. Example Configuration 4	A-53

A.7. General Comments	A-63
A.7.1. OS/3 ICAM Static Sessions	A-63
A.7.2. VLINEs	A-63
A.7.3. Multiple Paths between System 80 and DCP	A-63
A.7.4. OS/3 Terminal Spooling	A-63
A.8. Additional Documentation	A-64

Appendix B. Configuring UTS 20/40/400 Terminals

B.1. Terminal Configurations	B-1
B.2. Local Workstation Configurations	B-8
B.3. Remote Workstation Configurations	B-9

User Comments Form



Figures

2-1.	How to Specify SLCA Ports Using Automatic Dialing and Leased Lines	2-65
2-2.	Specifying a Primary Session	2-101
3-1.	Direct Data Interface (DDI) Network	3-8
3-2.	Coding for a Direct Data Interface (DDI) Network Definition	3-9
3-3.	Standard Interface Dedicated Network with No Auxiliary Devices	3-12
3-4.	Coding for a Standard Interface Dedicated Network with No Auxiliary Devices	3-13
3-5.	Standard Interface Dedicated Network Using a Message Processing Routine	3-14
3-6.	Coding for the Standard Interface Dedicated Network Using a Message Processing Routine	3-15
3-7.	Standard Interface Dedicated Network with Auxiliary Devices	3-17
3-8.	Coding for a Standard Interface Dedicated Network with Auxiliary Devices	3-18
3-9.	Disk Queued TCI Network with Auxiliary Devices	3-19
3-10.	Coding for the TCI Network with Auxiliary Devices and Disk Queuing	3-20
3-11.	Single-Node Standard Interface Global Network	3-22
3-12.	Multinode Global Network Environment	3-23
3-13.	ICAM Non-DCA and DCA Global Networks	3-24
3-14.	Single-Node Standard Interface Global Network Definition	3-31
3-15.	Global Network Supporting Workstations, IMS, and User-Written Programs	3-33
3-16.	Global Network Definition to Support Workstations, IMS, and User-Written Programs	3-34
3-17.	Global Network Supporting IMS, User-Written Program, and Interactive Services	3-36
3-18.	Global Network Definition to Support IMS, User-Written Program, and Interactive Services	3-39
3-19.	Global Network with Remote Workstations	3-43
3-20.	Global Network Supporting Remote Workstations and System Mode of Operations	3-44
3-21.	DCA Multinode Network Definition for Distributed Data Processing	3-48
3-22.	Multinode Distributed Data Processing with Interactive Terminal	3-50
3-23.	Interactive Terminal with Distributed Communications Processor	3-51
3-24.	Distributed Data Processing with a Distributed Communications Processor as an Intermediate Node	3-52
3-25.	DCA Network Using NRM to Transfer Files between an OS/3 and a UNIX O/S	3-53
3-26.	DCA Network Using NRM to Transfer Files between an OS/3 and a UNIX O/S Using a Switched Line	3-55
3-27.	OS/3-to-UNIX O/S Connectivity: SVT Emulation	3-56
3-28.	Typical DATEDX-L NORDIC Circuit-Switched PDN Environment (Computer to Computer)	3-61
3-29.	Sample ICAM Network Definition for a NORDIC Circuit-Switched PDN	3-63
3-30.	Typical NORDIC Circuit-Switched PDN Environment (Computer to UTS 20X Terminal)	3-67
3-31.	Sample ICAM Network Definition for a Circuit-Switched PDN (Computer to UTS 20X Terminal)	3-69
3-32.	Packet-Switched PDN Environment	3-71
3-33.	Typical DDX Packet-Switched PDN Environment with Three Computer Nodes	3-76

Figures

3-34.	ICAM Network Definition Coding to Support a 3-Node Packet-Switched DDX PDN	3-79
3-35.	Typical 2-Node DATAPAC/TRANSPAC/DATEX/IBERPAC Packet-Switched PDN Environment	3-84
3-36.	Sample 2-Node ICAM Network Definition Coding to Support a DATAPAC Packet-Switched PDN	3-85
3-37.	Sample 3-Node ICAM Network Definition Coding to Support a DATAPAC Packet-Switched PDN Using a Packet-Switched Terminal	3-89
3-38.	Sample ICAM Dedicated Network Definition for DATEX-L Circuit-Switched PDN	3-92
3-39.	Sample ICAM Global Network Definition for DATEX-L Circuit-Switched PDN	3-92
4-1.	Transaction Control Interface Network Definition Using Disk Files	4-5
4-2.	Sample Job Control Stream Showing How to Allocate Disk Queuing and Buffering Files	4-5
4-3.	Sample Network Definition Showing How to Create a Journal File for Buffer and Terminal Statistics	4-11
4-4.	Sample Network Definition Showing a Message Processing Routine for Journaling	4-12
4-5.	Network Definition Showing How to Incorporate User Own-Code Translation Tables	4-15
4-6.	Network Buffer/ARP Statistics Area Format	4-18
4-7.	Statistics Area for Network Buffers or ARPs	4-19
5-1.	Sample SYSGEN to Generate an ICAM Symbiont	5-3
5-2.	Sample Job Control Stream to Execute User Program	5-7
5-3.	Sample Job Control Stream to Execute GUST and User Programs	5-8
5-4.	Three Ways to Execute GUST in a Job Control Stream with and without Embedded Data Commands	5-11
A-1.	Example Configuration 1	A-28
A-2.	OS/3 ICAM Macros for Example Configuration 1	A-29
A-3.	Telcon Statements for Example Configuration 1	A-32
A-4.	Example Configuration 2	A-34
A-5.	OS/3 ICAM Macros for Example Configuration 2	A-35
A-6.	Telcon Statements for Example Configuration 2	A-38
A-7.	Example Configuration 3	A-41
A-8.	OS/3 ICAM Macros for Host C in Example Configuration 3	A-42
A-9.	OS/3 ICAM Macros for Host A in Example Configuration 3	A-47
A-10.	Telcon Statements for Example Configuration 3	A-51
A-11.	Example Configuration 4	A-54
A-12.	OS/3 ICAM Macros for Example Configuration 4	A-56
A-13.	DCP15 Telcon Statements for Example Configuration 4	A-59
A-14.	DCP40 Telcon Statements for Example Configuration 4	A-61

Tables

2-1.	Applicability of BUFFERS Macroinstruction and its Operands	2-4
2-2.	Applicability of CCA Macroinstruction and its Operands	2-15
2-3.	Applicability of CONGRP Macroinstruction and its Operands	2-24
2-4.	Call Progress Signal Action Default Values	2-26
2-5.	Applicability of CPSTB Macroinstruction and its Operands	2-27
2-6.	Applicability of DCPCHNL Macroinstruction and its Operands	2-30
2-7.	Applicability of DISCFIL Macroinstruction and its Operands	2-32
2-8.	Applicability of DLIST Macroinstruction and its Operands	2-36
2-9.	Applicability of EUP Macroinstruction and its Operands	2-39
2-10.	Applicability of JRNFILE Macroinstruction and its Operands	2-45
2-11.	Applicability of LDTE Macroinstruction and its Operands	2-48
2-12.	Applicability of LINE Macroinstruction and its Operands	2-52
2-13.	Line Characteristics and TYPE Specifications	2-59
2-14.	Line-Speed Values	2-60
2-15.	Maximum Line Speed of ICAM-Supported Terminals	2-60
2-16.	Applicability of LOCAP Macroinstruction and its Operands	2-77
2-17.	Applicability of LPORT Macroinstruction and its Operands	2-82
2-18.	Applicability of PDN Macroinstruction and its Operands	2-85
2-19.	Applicability of PGROUP Macroinstruction and its Operands	2-87
2-20.	Applicability of PRCS Macroinstruction and its Operands	2-90
2-21.	How Process File Queues Are Accessed	2-91
2-22.	Applicability of PVC Macroinstruction and its Operands	2-94
2-23.	Applicability of RDTE Macroinstruction and its Operands	2-97
2-24.	Applicability of SESSION Macroinstruction and its Operands	2-100
2-25.	Applicability of STATION Macroinstruction and its Operands	2-103
2-26.	Applicability of SUB Macroinstruction and its Operands	2-106
2-27.	Applicability of TERM Macroinstruction and its Operands	2-112
2-28.	Applicability of TRUNK Macroinstruction and its Operands	2-147
2-29.	Applicability of VCGROUP Macroinstruction and its Operands	2-150
2-30.	Applicability of VLINE Macroinstruction and its Operands	2-152
3-1.	Macroinstruction Usage by Network Definition Type	3-2
3-2.	OS/3 Basic Network Configurations	3-4
3-3.	Order of Presentation of Macroinstructions in a Direct Data Interface (DDI) Network Definition	3-7
3-4.	Order of Presentation for Macroinstructions in a Standard Interface and Transaction Control Interface Dedicated Network Definition	3-10
3-5.	Order of Presentation of Macroinstructions in a Global Network Definition	3-26
3-6.	Order of Presentation of Macros in a Network Definition for a Circuit-Switched PDN (Computer to Computer)	3-60
3-7.	End User Sessions for the Sample NORDIC Circuit-Switched PDN	3-66

Tables

3-8.	Order of Presentation for Macros in a Network Definition for a Circuit-Switched PDN (Computer to UTS 20X Terminal)	3-68
3-9.	Order of Presentation for ICAM Macros in a Definition for a Packet-Switched PDN	3-72
6-1.	Summary of Generation and Logon/Sign-on Procedures for Terminals/Workstations	6-2
A-1.	Order of Presentation of Macroinstructions in DCA Telcon Network Environment	A-7
A-2.	Telcon/ICAM Macroinstruction Relationships	A-24

Section 1

Introduction

1.1. Network Definition

An ICAM network definition is an orderly listing of macroinstructions that specify and define your communications network. This set of macros and the MCP parameter specifications are submitted to the system generation process of the operating system. System generation produces an ICAM symbiont.

All available network definition macros are described in Section 2 of this manual. Select only the macros necessary to define your communications network. All available MCP parameters are listed in Section 5 of this manual and are described in detail in the *OS/3 Installation Guide* (UP-8839).

For each network definition you supply during a system generation, the OS/3 system generation process automatically creates a communications control area (CCA) that includes all of the queues, tables, work areas, and buffer areas ICAM needs to support that network. In addition, the ICAM symbiont provides all of the processing modules that ICAM needs to support the networks you specify.

You can have multiple network definitions in one ICAM symbiont, and you can have up to 18 symbionts. (Only one ICAM symbiont can be loaded at a time, however.) Many users require only one network definition; therefore, they create only one communications control area in their ICAM symbiont and maintain only one ICAM symbiont.

There are two kinds of ICAM networks: dedicated and global. A dedicated network is so named because the resources it defines (terminals, queues, process files, etc.) are available only to your program that requests a dedicated network. Your program holds the resources until it releases the network.

A global network, on the other hand, enables two or more of your programs to attach themselves to the global network concurrently. This allows all of your programs to share the network resources and communicate with each other concurrently; that is, resources are globally available and not dedicated to one program at a time.

1.2. ICAM Interfaces to Your Program

There are several kinds of ICAM interfaces that you can use to communicate with ICAM end users from your program. Each one is designed for certain applications. The interface you choose depends on the intended functions of your network.

1.2.1. Interfaces for Dedicated Networks

There are three interfaces you can use for dedicated networks. Each interface provides your program with a different level of support or with a set of unique characteristics.

- Standard Interface (STDMCP)

STDMCP isolates your program from the physical aspects of communications. ICAM handles all input and output, and you can devote all of your program to message processing.

- Transaction Control Interface (TCI)

TCI is similar to the standard interface, but it is used only to support the information management system (IMS).

Note: For complete details on generating an ICAM network that supports IMS, see the *IMS System Support Functions Programming Guide* (UP-11907).

- Direct Data Interface (DDI)

DDI is a minimum configuration interface that still handles the physical aspects of communications, but your program must direct ICAM activity. Your program interfaces directly with the ICAM remote device handlers, thus allowing you to design a specialized communications configuration.

1.2.2. Global Network Definitions

In a global network, multiple programs using different interfaces can use the same network concurrently. Therefore, the communications network cannot belong to any specific interface. The network is designated as global, and each program is defined as an end user with a LOCAP macro to specify its required interface.

The interfaces permitted in a global network include STDMCP and TCI, which were explained in 1.2.1. DDI is not supported in global networks; however, one additional interface, the demand mode interface (DMI), is available for global networks.

DMI is required for users of ICAM interactive services and distributed data processing (DDP). Interactive services is described in the *Interactive Services Operating Guide* (UP-9972); and DDP is described in the *Distributed Data Processing Programming Guide* (UP-8811).

1.2.3. Special ICAM Interfaces

ICAM also provides interfaces for special purposes.

- Communications Physical Interface (CPI)

CPI allows your program to work directly with your single-line communications adapter at the physical level for special configurations. This interface is described in the *ICAM CPI Programming Guide* (UP-9746).

- Remote Batch Processing (RBP)

RBP is an ICAM utility that allows you to submit jobs from a remote station and receive output at one or more remote stations. This utility requires a dedicated network and is described in the *ICAM Utilities Programming Guide* (UP-9748).

- Nine Thousand Remote (NTR)

NTR is an ICAM utility that allows you to use System 80 as a remote job entry/batch terminal to a Series 1100 data processing system. This utility requires a dedicated network and is described in the *NTR Utility Programming Guide* (UP-9502).

1.3. Terminology Used in This Manual

An ICAM symbiont is a load module composed of many routines linked by your network definition and the system generation process. Occasionally, this manual discusses one of the ICAM functions; however, when we say a function is performed by ICAM, we mean that the function is performed by one or more of the ICAM routines contained in the ICAM symbiont rather than by your program.

Programs you write to solve a problem or process an application (that use communications) are known by many names:

- Communications user program
- Communications program
- User program
- Program
- CUP

All of the terms listed refer to the applications program that you write using the interfaces and other facilities of ICAM. Typically, your applications program accepts input messages, processes the data contained therein, stores the results in a file at the computer site, or sends the results to a remote destination.

Applications programs written for ICAM are no different from any other program you might write, except that they use ICAM macros to interface with ICAM. Your program can perform any other functions you wish, in addition to its communications functions. Therefore, throughout this manual, we refer to the applications program that you write simply as your *program*.

1.4. Using the ICAM Dialog to Define a Network

This manual describes the normal method of defining an ICAM network. However, you may define an ICAM network by using a dialog supplied by Unisys. A description of the dialog and its use for System 80 appears in the *OS/3 Installation Guide* (UP-8839). Should you choose to use the dialog, you cannot generate an NTR, an RBP, a DCA termination system, or a message processing routine by using the MPPS macros. When you use the ICAM dialog, you should read this manual first so that you can prepare yourself to respond properly to the questions asked by the dialog.

Section 2

Network Definition Macroinstructions

2.1. General Description

This section provides the macroinstruction repertoire used to define ICAM networks. The macros are in alphabetical order. Each macro description includes a list of operands and applicable network types.

Macro	Description
BUFFERS	Establishes network and activity request packet pools and creates other resources needed by ICAM
CCA	Identifies the beginning of a network, the type of network, ICAM features, and journaling requirements
CGRPEND	Indicates the end of a UDLC/NRM configuration group definition
CONGRP	Defines a UDLC/NRM configuration group by indicating a set of local and remote stations to be connected to a particular line (VLINE)
CPSTB	Defines the entries in a call progress signal table for a circuit-switched public data network
DCPCHNL	Specifies DCP channel characteristics
DISCFILE	Defines a disk file for use by ICAM
DLIST	Creates a list of destinations (a distribution list) in your network
ENDCCA	Indicates the end of a network definition
EUP	Formats output messages to terminals
JRNFILE	Defines a journal file
LDTE	Defines the attributes of a local data terminal equipment (DTE) in a circuit-switched public data network

Network Definition Macroinstructions

Macro	Description
LINE	Establishes the characteristics of each communications line in your communications network
LOCAP	Creates a locap file for your programs that use global networks
LPORT	In distributed communications architecture, enables ICAM to record and control activity at a logical port
PDN	Defines attributes of a public data network
PGROUP	Specifies polling groups and polling intervals for remote work station
PRCS	Defines a process file for temporary storage of messages
PVC	Defines a permanent virtual circuit on a packet-switched public data network
RDTE	Defines the attributes of a remote data terminal equipment (DTE) in a circuit-switched public data network
SESSION	Defines a static session in a global network
STATION	Defines the unique characteristics of a station required by a UDLC/NRM link level control
SUB	Defines a remote subscriber on a packet-switched public data network
TERM	Defines the characteristics of each terminal
TRUNK	Defines a trunk on a packet-switched public data network
VCGROUP	Defines a virtual circuit group on a DDX or PSS packet-switched public data network
VLINE	Defines the physical link between two computer nodes in a multinode global network

2.2. How to Specify Buffer Pools, Activity Request Packet Pools, and Other ICAM Resources (BUFFERS)

Use the BUFFERS macro to create a network buffer pool, an activity request packet pool, and optionally, a link buffer pool and a user data unit control table pool (UDUCT). All pools are located within your network communications control area. BUFFERS also specifies the number, size, and threshold values for the user data unit control tables and link buffer packets for distributed data processing and public data networks. You may also specify statistical areas to keep track of ICAM's use of the pools so you can adjust pool sizes according to your needs.

You need to specify BUFFERS in all network definitions except the communications physical interface. It may be specified only once in each network definition.

Format

LABEL	OPERATION	OPERAND
not used	BUFFERS	[num,size][,thresh] [,EXPFACT= { n }] ,ARP=integer [,STAT=YES] [,OPCOM= { num }] [,THOLD=n] [,UDUCT=(num[, , thresh])] [,LINKPAK=(num,size[, thresh])] [,RTIMER= { (num) }]

Table 2-1 describes the interface and type of network definition in which you may use BUFFERS. It also details the applicability of each operand. The first line in the table is the name of the macro preceded by an asterisk (to distinguish it from its operands).

BUFFERS

Table 2-1. Applicability of BUFFERS Macroinstruction and Its Operands

Macro: BUFFERS	ICAM Network Type and Kind of Program Supported											
	Direct Data Interface		Dedicated Networks			Global Networks						
Operand Name	DDI	RBP	TCI (IMS)	STDMCP	CMCS (COBOL)	STDMCP	TCI (IMS)	COBOL	DMI	Multinode Non-DCA	DCA	Public Data Networks
	NTR											
	RPG											
	IDES											
*BUFFERS	R	R	R	R	R	R	R	R	R	R	R	R
num	-	-	R	R	R	R	R	R	-	R	R	R
size	-	-	R	R	R	R	R	R	-	R	R	R
thresh	-	-	O	O	O	O	O	O	-	O	O	O
ARP=	R	R	R	R	R	R	R	R	R	R	R	R
EXPFACT=	O	O	O	O	O	O	O	O	O	O	O	O
LINKPAK=	-	-	-	-	-	O	O	O	O	O	O	R
OPCOM=	O	-	O	O	O	O	O	O	O	O	O	O
RTIMER=	-	-	-	-	-	-	-	-	-	-	O	-
STAT=	O	O	O	O	O	O	O	O	O	O	O	O
THOLD=	O	O	-	-	-	-	-	-	-	-	-	-
UDUCT=	-	-	-	-	-	O	O	O	O	O	O	R

*Shows macro applicability

LEGEND:

R = Required O = Optional - = Not applicable

Operands**num**

Specifies the number of network buffers you want in your network buffer pool. The number you need depends on your message traffic, the number of lines you have, the interface you are using, and your program. However, because ICAM gives priority to output messages, you can usually determine the number you need by estimating the maximum number and length of output messages that can be in the system at any time.

Note: Specify num for the direct data interface only if datagrams are to be transferred (see notes under size operand). (A datagram is an optional message transferred to your program when it is activated by a GAWAKE macro.)

size

Is the length of your network buffers in 4-byte words.

When your program is communicating with an interactive terminal such as a UTS 400 or UTS 4000 terminal, you don't need to fit an entire message into a single network buffer; ICAM uses additional network buffers until the entire message is accommodated. However, for maximum throughput, you should specify a value large enough so that 90 per cent of your messages fit into the first network buffer.

When your program is communicating with a batch device such as a card reader, a card punch, or a printer, you must make sure each record fits into the portion of a network buffer available to you. Usually, this means that your network buffer size will be greater than 20 words (80 bytes) for punched cards and greater than 33 words for a printer (132 characters), i.e., record size plus message header prefix size.

As you can see in the following illustration, network buffer size is always somewhat larger than the size of the message data, or of a record in the case of a batch device. ICAM inserts a message header prefix at the beginning of the first network buffer and your message fills the remaining space in the network buffer.

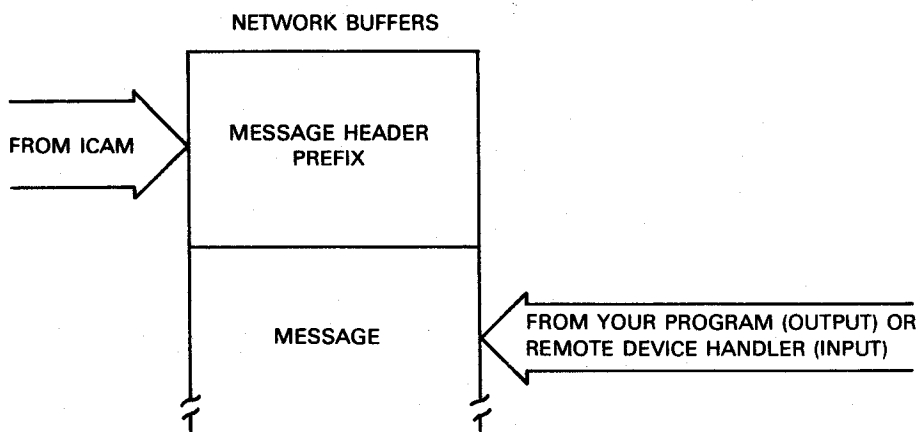

The message header prefix contains control information used by ICAM. The space occupied by the message header prefix varies as follows:

- 88 bytes when main storage queueing is used
- 100 bytes when disk queueing is used
- 112 bytes when journaling is used
- 120 bytes when distributed communications architecture is used

Subsequent network buffers contain:

- 16-byte segment prefixes when disk queueing is used
- 12-byte prefixes when disk queueing is not used

These prefixes are used to link the network buffers when more than one is needed to hold your message. Each network buffer is filled with your message starting at the first byte following the message header prefix and segment prefixes.

Notes:

1. *Network buffer size must be a minimum of 208 (decimal) bytes (52 words) when a global network uses dynamic sessions. This size (which includes the message header) ensures that any messages generated by the OS/3 command language processor, due to attempts by a program or a terminal operator to establish a dynamic session, will fit into a single network buffer.*
2. *You should not specify the num and size operands if your program is using the direct data interface unless your program is to receive datagrams. If so, you must specify sufficient network buffers to hold all datagrams that can be present until they are delivered. All network buffers used to hold datagrams contain a 12-byte message header prefix.*

thresh

Specifies a threshold value that is the minimum number of inactive network buffers you will allow before ICAM temporarily stops polling for input. This allows ICAM to concentrate on sending output until enough network buffers become available to resume input. We suggest you specify a value of 10 to 15 percent of the number of buffers you specify in the *num* operand.

When used in conjunction with buffer pool expansion, ICAM attempts to expand the buffer pool when the threshold value is reached. If ICAM is able to expand the buffer pool, processing continues because more buffers are available for use. Otherwise, threshold processing takes place as described.

Notes:

1. *The thresh operand is not used in the direct data interface.*
2. *If you specify this operand, a threshold for activity request packets is also established that is approximately 10 percent of the number of packets you specify.*
3. *ICAM always checks to see if sufficient buffers are available in the network buffer pool without entering threshold processing before it honors an output request. If not, your program receives control at its no-buffer-available (NOBAV) address, and the output request is rejected. This prevents output requests from causing the loss of input messages in process when a threshold condition occurs.*
4. *You should always specify a threshold of at least enough network buffers to hold one message.*

EXPFACT=n

Specifies an ICAM buffer pool expansion factor. You may specify 0 to 100 (percent). The default is 25.

ICAM automatically expands the number of buffers in a given buffer pool by the factor specified in this operand whenever the number of inactive buffers in that pool equals the value specified in the *thresh* operand. This operand applies to all ICAM buffer pools (network buffer, ARP, UDUCT, LINKPAC, and so on), but only the pool that reaches the threshold value is expanded. If the first increment is exhausted, additional increments are added until peak requirements are met or main storage resources are exhausted.

If you specify EXPFACT=0, no buffer pool expansion is performed. However, the buffer pool services expansion routine is automatically included in ICAM unless you specify BPOOLEXP=NO in the MCP portion of COMMCT at system generation.

ARP=integer

Creates an activity request packet pool. The number you specify is the number of 14-word (56-byte) activity request packets available to ICAM to perform its functions.

Activity request packets are essential to ICAM, and you must assign enough of them. We recommend the following based on the interface you are using:

Interface	Minimum Number of Packets
Standard Interface	5 per line + 4 per network + 2 per process file + special functions

Interface	Minimum Number of Packets
TCI	7 per line + 4 per network + special functions
DDI	4 per line + 4 per network + special functions
DCA sessions	6 + 6 per line + special functions
Circuit-Switched PDN	6 + 10 per line + special functions
Packet-Switched PDN (must be DCA)	Use the following formula.

Calculate the number of activity request packets with the formula:

$$\text{num} = \text{vc} + \text{trks} + \text{tsess}$$

where:

vc
Is the number of virtual circuits on all packet-switched public data networks.

trks
Is the number of trunks in the ICAM network.

tsess
Is the maximum number of sessions that may be active simultaneously on all virtual circuits.

Special functions:

- If your program issues multiple output messages to multidrop lines, add one activity request packet for each terminal.
- If you issue a long series of requests to ICAM with IRL set, add one activity request packet for each call over 3.
- If you are using DCA, you must allow six activity request packets for ICAM, six for each configured line or DCP channel, and one for each session allowed. DMI users should allow three activity request packets per interactive services session and three per DDP session.

STAT=YES

Creates statistics areas for the network buffer pool, the activity request packet pool, LINKPAK, and UDUCT. (See 4.6 for a detailed description of the statistics area.)

OPCOM= { num }
 { 3 }

Specifies the number of operator communication packets used for unsolicited key-in messages. Determine this number based on how you operate the network. If you use many unsolicited key-ins to ICAM in rapid succession, you should consider increasing this number to more than 3, which is the default.

THOLD=n

Specifies a threshold for activity request packets used with the direct data interface only. When you use the direct data interface, the *thresh* operand does not apply; therefore, if you want a threshold on activity request packets, you must specify this operand. The THOLD operand causes a threshold processing module to be included in ICAM. If you are sure you will never run out of activity request packets, you can omit this operand to save storage.

UDUCT=(num, [, thresh])

Specifies the number of user data unit control tables, which are always 28-word areas that control data transmission and supply information about messages (senders, receivers, ports, and sessions) in DDP, remote workstation, Telcon, and processor-to-processor networks.

For non-RWS configurations, allow at least 1.5 times the maximum number of sessions that would be active at any given time. Set the *thresh* value to 3.

When using remote workstations, calculate the minimum number of user data unit control tables (UDUCTs) with the formula:

$$\text{num} = 2 \times \text{number of TERM macros specified for remote workstations}$$

and set the threshold number by:

$$\text{thresh} = 10\% \text{ of value specified for num}$$

LINKPAK=(num, size[, thresh])

Specifies the number, size, and threshold value of link buffers. You use these with DDP, remote workstation support, public data networks, Telcon networks, and processor-to-processor networks.

BUFFERS

num

Specifies the number of link buffers.

For DDP, Telcon, processor-to-processor, or circuit-switched public data networks, use the following formula to determine the maximum number required; then add it to any other link buffers needed in the network.

$$\text{num} = (\text{mpm} \times \text{maxsess}) + 1/2 \text{maxsess}$$

where:

num

Is the number of link-buffers for this network.

mpm

Is the number of link buffers required to hold the largest message passed over a UDLC/DCPCHNL line. Compute *mpm* by dividing the length of the largest message by the value specified in the *mxdata* parameter on the size of formula (rounded to the next whole word).

maxsess

Is the maximum number of sessions that will be active on a UDLC/DCPCHNL at any given time.

For a packet-switched public data network, determine the maximum number you need by using the following formula, and add to it any other link buffer needs in the network:

$$\text{num} = (\text{maximum ws or mpm (whichever is larger)} + \text{mpm} + \text{ws}) \times \text{maxsess}$$

where:

num

Is the number of link-buffers for this packet-switched public data network.

ws

Is the window size.

mpm

Is the number of data packets required to hold the largest message passed over the circuit. Compute *mpm* by dividing the length of the largest message by the value specified in the *PKTSIZ* operand on the *PDN* macro (rounded to the next whole word).

maxsess

Is the maximum number of sessions that will be multiplexed over this network.

When using remote workstations, calculate the minimum number of link buffers with the following formula:

$$\text{num} = 3 \times \text{number of TERM macros specified for remote workstations}$$

size

Specifies the length of the link buffer in words (one word equals four bytes). If you have a mix of line types, use the formulas given and take the largest calculated value.

For remote workstation (RWS), specify 80.

If you are using DDP, Telcon, processor-to-processor, or circuit-switched public data networks, use the following formula:

$$\text{size} = (\text{prfxhdr} + \text{mxdt})/4$$

where:

prfxhdr

Is the length of the link buffer prefix plus headers (74 bytes if using a VLINE, 84 bytes if using a DCPCHNL).

mxdt

Is an average data size (bytes) to be transmitted. Larger output will be broken into segments.

4

Converts *prfxhdr* and *mxdt* to words.

If you are using a packet-switched public data network, try the following formula:

$$\text{size} = (1\text{bprfx} + 2\text{hdr} + 3\text{hdr} + \text{mxdt})/4$$

where:

1bprfx

Is the length of the link buffer prefix (40 bytes).

2hdr

Is the length of the level 2 header (2 bytes).

3hdr

Is the length of the level 3 modulus for the public data network (three bytes for modulus 8, and four bytes for modulus 128).

mxdta

Is the value specified on the PKTSIZ operand of the PDN macro.

4

Converts all of the above to words.

Note: When a 56,000 baud VLINE is specified in the CCA, the linkpak size must be at least 280 words.

thresh

Specifies a threshold value. It is not required for public data networks.

For non-public data networks, use the following formula:

$$\text{thresh} = 10\% \text{ of value specified for num}$$

Note: *num* & *thresh* decrease when *SIZE* increases.

RTIMER=(num)

Specifies the number of 3-word timer stack entries used with Telcon, processor-to-processor, and DDP. Maximum number needed should equal the number of ports plus the number of active sessions. The default value is 50.

Examples

How you specify the BUFFERS macro depends on the interface you are using and the activity of your system. The following examples illustrate the use of BUFFERS in a standard interface network and a direct data interface network. The use of BUFFERS in a dedicated transaction control interface is similar to that shown for the standard interface.

Example 1: In this standard interface example, a network buffer pool of twenty-five 100-word (400-byte) network buffers is established. A threshold of 3 network buffers, and an activity request packet pool of 15 packets and five 21-word (84-byte) operator communication packets are requested.

```

1                                                                    72
-----
NETW  CCA  TYPE=(STDMCP),PASSWORD=JHB1,                               X
        FEATURES=(OPCOM,OUTDELV)
        BUFFERS=25,100,3,ARP=15,OPCOM=5
LNE1  LINE DEVICE=(UNISCOPE),                                         X
        TYPE=(2000,SWCH,SYNC),                                       X
        CALL=2997,                                                    X
        INPUT=(PRC1)
TRM1  TERM ADDR=(28,51),                                             X
        FEATURES=(U400,1920),                                         X
        HIGH=MAIN,MEDIUM=MAIN,LOW=MAIN
PRC1  PRCS LOW=MAIN
        ENDCCA

```

Example 2: In this direct data interface network, 24 activity request packets are specified for the activity request packet pool. The pool has a 4-packet threshold. Notice that no network buffers are used, which is normal for this interface, except when datagrams are sent to your direct data interface program.

```

1                                                                    72
-----
NETW  CCA  TYPE=(DDI,3),FEATURES=(OPCOM)
        BUFFERS=ARP=24,THOLD=4
LNE1  LINE DEVICE=(UNISCOPE),                                         X
        TYPE=(2000,SWCH,SYNC),                                       X
        CALL=2997
TRM1  TERM ADDR=(28,51),                                             X
        FEATURES=(U400,1920),                                         X
        AUX1=(TCS,73,74),                                             X
        AUX3=(TCS,75,76)
        ENDCCA

```

2.3. How to Indicate the Start of Your Network Definition and Specify General Network Characteristics (CCA)

The CCA macro identifies the beginning of an ICAM network definition, the type of network, and the kind of support you want ICAM to provide in the network.

You use CCA in all network definitions, and it may be specified only once in each network definition. See the *ICAM Communications Physical Interface Programming Guide* (UP-9746) for using the CCA macro with the CPI.

Table 2-2 describes the interface and type of network definition in which you may use CCA. It also details the applicability of each operand. The first line in the table is the name of the macro itself preceded by an asterisk (to distinguish it from its operands).

Format

LABEL	OPERATION	OPERAND
network-name PLOCS	CCA	<pre> TYPE= ((STDMP) (GBL, ,node) (DDI, level) (TCI) (RBP1) (RBP2)) [, DUSTERR=INLINE] [, PASSWORD=password] [, SAVE=YES] [, CCAID=identifier] [, DCA=YES] [FEATURES= ([, AUTOBUF] [, OPCOM][, BASIC] [, OUTDELV][, RESTART][, SEGMENTS] [, DATIME][, MONITOR]) [, JRNINIT= ([RESTART][, PERF] [, STAT][, JOURN] [, ODNR]) [, GAWAKE=YES] [, USERS=number] [, DESPACE= (U Y N) [, DCPLOAD=YES] </pre>

Table 2-2. Applicability of CCA Macroinstruction and Its Operands

Macro: CCA	ICAM Network Type and Kind of Program Supported											
	Operand Name	Direct Data Interface		Dedicated Networks			Global Networks					
DDI		RBP	TCI (IMS)	STDMCP	CMCS (COBOL)	STDMCP	TCI (IMS)	COBOL	DMI	DCA	Public Data Networks	
NTR	RPG										IDES	CS
*CCA	R	R	R	R	R	R	R	R	R	R	R	R
label	R	R	R	R	R	R	R	R	R	R	R	R
CCAID=	O	O	O	O	O	O	O	O	O	O	O	O
DCA=	-	-	-	-	-	O	O	O	O	R	R	R
DESPACE=	-	-	-	-	-	-	-	-	O	O	O	O
DUSTERR=	O	-	-	O	-	O	-	-	-	-	-	-
FEATURES=	O	O	O	O	R	O	O	R	O	O	O	O
AUTOBUF	-	-	-	-	-	-	-	-	-	-	-	-
BASIC	O	-	O	O	-	-	-	-	-	-	-	O
DATIME	-	-	-	O	R	O	-	R	-	O	O	O
OPCOM	O	O	O	O	O	O	O	O	O	O	O	O
OUTDELV	-	-	-	O	-	O	-	-	-	O	O	O
RESTART	-	-	-	O	O	O	O	O	-	O	O	O
SEGMENTS	-	-	-	O	R	O	-	R	-	O	O	O
MONITOR	O	O	O	O	O	O	O	O	O	O	O	O
GAWAKE=	O	-	O	O	-	O	O	O	O	R	O	O
JRNINIT=	-	-	O	O	O	O	O	O	-	O	O	O
JOURN	-	-	O	O	O	O	O	O	-	O	O	O
ODNR	-	-	O	O	-	O	O	-	-	O	O	O

* Shows macro applicability

LEGEND: R = Required
 O = Optional
 - = Not applicable

CS = Circuit-switched
 PS = Packet-switched

continued

Table 2-2. Applicability of CCA Macroinstruction and Its Operands (cont.)

Macro: CCA	ICAM Network Type and Kind of Program Supported											
Operand Name	Direct Data Interface		Dedicated Networks			Global Networks						
	DDI	RBP										
	NTR											
	RPG		TCI (IMS)	STDMCP	CMCS (COBOL)	STDMCP	TCI (IMS)	COBOL	DMI	DCA	Public Data Networks	
	IDES		CS	PS								
PERF	-	-	O	O	O	O	O	O	-	O	O	O
RESTART	-	-	O	O	O	O	O	O	-	-	-	-
STAT	-	-	O	O	O	O	O	O	-	O	O	O
PASSWORD=	O	O	O	O	O	O	O	O	O	O	O	O
SAVE=	-	-	-	-	R	-	-	R	-	-	-	-
TYPE=	R	R	R	O	R	R	R	R	R	R	R	R
USERS=	-	-	-	-	-	-	-	-	-	-	-	-

LEGEND:

- R = Required
- O = Optional
- = Not applicable
- CS = Circuit-switched
- PS = Packet-switched

Label

network-name

Is a 1- to 4-character label beginning with an alphabetic character that identifies this network. This is the label your program refers to when it requests a dedicated network or releases a dedicated network. When you use a global network, this is the name the global user service task (GUST) needs to activate your global network.

PIOCS

Required label for a CPI network only.

Note: A CPI CCA must be the last one defined in a multiple CCA generation.

Operands**TYPE=(STDMCP)**

Indicates this is a standard interface dedicated network definition.

TYPE=(GBL,,node)**GBL**

Indicates this is a standard interface global network definition.

Note: Two commas must follow the GBL operand.

node

Is a 1- to 4-character computer node identifier for the computer in which this network operates. Any non-null character string that begins with an alphabetic character may be specified. This identifier must not match the label field of any other macro within the network definition.

TYPE=(DDI,level)**DDI**

Indicates this is a direct data interface network definition.

level

Is the level of direct data interface support you need. You must specify 3, 2, or 1, where:

- 3 Provides full direct data interface support including:
 - RPG telecommunications, NTR, and IDES utilities
 - batch mode operation
 - multiple output message control table (MCT) support for UNISCOPE[®] and UTS 400 terminals
 - auxiliary device support
 - wait for end of message in the last line buffer logic
- 2 Provides the same support as 3, except batch mode of operation is not provided.
- 1 Provides minimum support without any of the items listed for 3. It is for use in systems having minimal main storage available.

UNISCOPE is a registered trademark of Unisys Corporation.

TYPE=(TC1)

Indicates this is a transaction control interface dedicated network definition supporting the information management system (IMS).

Note: For complete details on generating an ICAM network that supports IMS, see the IMS System Support Functions Programming Guide (UP-11907).

TYPE=(RBP1)

Indicates RBP support is fully resident.

TYPE=(RBP2)

Indicates RBP support is a multiphase load module.

DUSTERR=INLINE

Specifies that, if an error occurs during DUST macro processing, all returns are inline. If you don't specify DUSTERR=INLINE and an error occurs during DUST processing, ICAM returns control at the NETREQ macro ERRET=address you specify.

Note: The DUSTERR=INLINE specification is correct only when your program is coded to match the operand you specify.

PASSWORD=password

Is a 1- to 8-character password you specify to further identify this network. If you specify a password, you must use it in all requests for this network.

SAVE=YES

Saves a copy of this network definition in the system object library (\$Y\$OBJ) file on your system resident volume. If you are going to use this network definition in conjunction with a COBOL program (and with the COBOL message control system (CMCS)), you must specify this operand.

CCAID=identifier

Specifies a 1- to 8-character identifier (word, label, code, and so on) that you want printed on each page of your network definition assembly listing and the summary report at the end of the listing. This makes it easier for you to locate your network.

DCA=YES

Indicates support of distributed communications architecture (DCA). This operand is also required for all remote workstations and packet-switched and the NORDIC circuit-switched public data networks. (Note that you must also specify GAWAKE=YES.)

FEATURES=**AUTOBUF**

Includes automatic line buffering routines to support field-written remote device handlers. You should not specify this operand if you are using remote device handlers provided by Unisys. This operand is used in a CPI.

OPCOM

Includes routines necessary to support unsolicited console type-ins to ICAM. This feature is not supported for NTR networks.

BASIC

Includes a basic (minimum) teletypewriter or UNISCOPE remote device handler in ICAM. If you require a more sophisticated version of either handler, do not specify this operand.

OUTDELV

Includes routines to support the ICAM output delivery notice feature.

RESTART

Includes disk queueing routines to enable a *warm restart*. Warm restart enables you to have ICAM recover messages from disk storage queues in the event of a system failure or if you close a network before all messages on disk are delivered.

SEGMENTS

Includes routines to support segmented message processing. If you need to send or receive messages in discrete segments, you must specify this operand.

DATIME

Includes the routine necessary for ICAM to date and time stamp all queued messages.

MONITOR

Specifies that the system activity monitor (SAM) is to be linked into the communications control area. This utility accumulates data about your system performance. The *ICAM Technical Overview (UP-9744)* gives detailed information on how to use this monitor.

Note: Normally, you are not allowed to split (continue) an operand on a subsequent statement. However, because the *FEATURES* operand is exceptionally long, and you might need most or all of its suboperands, special provisions have been made to permit you to code it like separate keyword operands.

For example, you may code:

1	72		
<hr/>			
NET1	CCA	TYPE=(STDMCP),DUSTERR=INLINE,	X
		FEATURES=(AUTOBUF),	X
		FEATURES=(OPCOM,BASIC),	X
		FEATURES=(OUTDELV,RESTART),	X
		FEATURES=(SEGMENTS),	X
		JRNINIT=(RESTART),	X
		GAWAKE=YES	

JRNINIT=

RESTART

Includes routines necessary to maintain *restart* records. ICAM writes restart records to a history file to permit disk queues to be rebuilt by a journal utility should ICAM fail due to a queueing disk failure.

PERF

Includes routines to maintain line and terminal performance records.

STAT

Includes routines to maintain network buffer and activity request packet pool statistics.

JOURN

Includes journaling routines to capture journal records. Journal records contain the full text of messages passing through ICAM plus certain control information.

ODNR

Includes the routines necessary to produce output delivery notice records. These refer to journal records and signify that the referenced message was dequeued for delivery to a terminal or a communications user program, or that a message was canceled.

GAWAKE=YES

Includes the routines to support the ICAM GAWAKE feature. The GAWAKE feature enables any task to activate an ICAM user program that has yielded, and to optionally send to the user program a message known as a datagram.

If you want dynamically established sessions in your global network, specify this operand.

USERS=number

This operand applies only to the communications physical interface and is the decimal number of physical user programs that will use the physical network.

DESPACE=

Specifies the action to be taken by ICAM or interactive services for loading the destructive space specification of the control page. This parameter applies only to remote workstations, UNISCOPE terminals, and UNISCOPE-type devices attached to a DCP.

DESPACE=U

The destructive space parameter is not to be altered (that is, it remains set as previously specified in the control page). This is the default value.

DESPACE=Y

The destructive space parameter is set each time ICAM or interactive services loads the control page.

DESPACE=N

The non-destructive space parameter is set each time ICAM or interactive services loads the control page.

Note: *The release 12.0 enhancement for ICAM destructive space definition is restricted for use by terminals located on a cluster controller, which are not loaded with the correct ICAM gen specification for DESPACE=U/Y/N. To obtain the desired destructive space setting, you must manually change the control page specification or use the interactive services SCREEN command.*

DCPLOAD=YES

This operand must be included if a DCP is to be downline loaded or cross-channel loaded by ICAM.

Examples

The following examples show the use of the CCA macro.

Example 1: A dedicated network definition.

```

1                                                                    72
-----
NETW   CCA   TYPE=(STDMCP),DUSTERR=INLINE,PASSWORD=JHB,           X
        FEATURES=(OPCOM,OUTDELV)
        BUFFERS 10,64,1,ARP=24

```

Example 2: A global network definition.

```

1                                                                    72
-----
NET1   CCA   TYPE=(GBL,,S),DUSTERR=INLINE,FEATURES=(OPCOM),GAWAKE=YES

```

2.4. How to Indicate the End of a UDLC/NRM Configuration Group (CGRPEND)

This macro indicates the end of a CONGRP definition.

Format

LABEL	OPERATION	OPERAND
not used	CGRPEND	not used

2.5. How to Configure Groups in a UDLC/NRM Link (CONGRP)

This macro is required whenever the UDLC/NRM link control feature is included in a DCA network generation. It defines configuration groups as sets of local and remote stations, and each set is connected to a particular line (VLINE).

Table 2-3 describes the interface and type of network definition in which you may use this macro. It also details the applicability of each operand in the macro. The first line in the table is the name of the macro itself preceded by an asterisk (to distinguish it from its operands).

Format

LABEL	ΔOPERATIONΔ	OPERAND
symbol	CONGRP	CAT=A ,TYPE=UDLC,DCA2 [,CONNTYP= ({ ACTIVE } ,AUTO) { PASSIVE }]

Label

symbol

Is a required 1- to 4-character label that identifies a configuration group.

Operands

CAT=A

Specifies an NRM configuration group which consists of a single VLINE connecting a single local and remote station pair.

TYPE=(UDLC,DCA2)

Indicates the link level protocol and network type for this group.

CONNTYP= ({ ACTIVE } ,AUTO)
 { PASSIVE }

Identifies the type of connection processing performed during line initialization or in response to a connect request.

This parameter specifies that the initialization completion notification is delayed until an operational mode is established. A local station defined as PRIMARY sends an SNRM frame to a remote station. A local station defined as SECONDARY opens to receive an SNRM frame.

When you specify this option for a single-switched VLINE configuration type, a physical connection is attempted. After it is completed, the UDLC handler initiates "Go Operational" procedures.

ACTIVE

Specifies auto or manual dial-out to the remote host.

PASSIVE

Indicates that the remote host dials in to the local host (unattended answering).

AUTO

Identifies the type of connection processing performed by the UDLC handler during line initialization or in response to a connect request.

Table 2-3. Applicability of CONGRP Macroinstruction and Its Operands

Macro: CONGRP	ICAM Network Type and Kind of Program Supported										
	Direct Data Interface		Dedicated Networks			Global Networks					
Operand Name	DDI	RBP	TCI (IMS)	STDMCP	CMCS (COBOL)	STDMCP	TCI (IMS)	COBOL	DMI	DCA	Public Data Networks
	NTR										
	RPG										
	IDES										
*CONGRP	-	-	-	-	-	-	-	-	-	O	-
label	-	-	-	-	-	-	-	-	-	R	-
CAT=	-	-	-	-	-	-	-	-	-	R	-
TYPE=	-	-	-	-	-	-	-	-	-	R	-
CONNTYP=	-	-	-	-	-	-	-	-	-	O	-

*Shows macro applicability

LEGEND:

R = Required O = Optional - = Not applicable

2.6. How to Create a Call Progress Signal Table for a Circuit-Switched Public Data Network (CPSTB)

When a circuit-switched PDN cannot immediately establish a circuit, it reports this status to ICAM as a call progress signal. If you do not wish to use the default values given in Table 2-4, you can use this macro to build your own table of actions for ICAM to take when the circuit-switched network returns a call progress signal.

You build your own call progress signal table by defining a series of CPSTB macros. You identify the table with a label for the first CPSTB macro and indicate the end of the table by specifying the END operand in the last CPSTB macro.

Table 2-5 describes the interface and type of network definition in which you may use this macro. It also details the applicability of each operand in the macro. The first line in the table is the name of the macro itself preceded by an asterisk (to distinguish it from its operands).

Format

LABEL	OPERATION	OPERAND
[symbol]	CPSTB	CPS= { n { n ₁ , n ₂ , n _n } [,NOR= (({ slca-nor } , { icam-nor })) [,TBR= (({ slca-tbr } , { icam-tbr })) [,TBD= { time-before-disconnect } [,END=cpstb-symbol]

Label

symbol

Is a 1-to 4-character label that identifies the start of a call progress signal table. This label is used only on the first of a series of one or more CPSTB macros.

Table 2-4. Call Progress Signal Action Default Values

Call Progress Signal		SLCA		TBD	ICAM	
		NOR	TBR		NOR	TBR
01	Terminal called	0	0	60	0	0
02	Redirected call	0	0	2	0	0
03	Connect when free	0	0	2	0	0
20	No connection	3	5	0	10	300
21	Number busy	3	5	0	50	300
22	Local procedure error	3	2	0	0	0
23	Selection signal transmission error	3	2	0	50	300
41	Access barred	1	0	0	0	0
42	Changed number	1	0	0	0	0
43	Not obtainable	1	0	0	0	0
44	Out of order	1	0	0	50	1200
45	Controlled not ready	3	2	0	50	60
46	Uncontrolled not ready	3	2	0	50	1200
47	DCE power off	1	2	0	50	1200
48	Invalid facility request	1	0	0	0	0
49	Network fault local	3	2	0	0	0
51	Call information	1	0	0	0	0
52	Incompatible user	1	0	0	0	0
61	Network congestion	3	2	0	50	300
71	Long-term network congestion	1	10	0	50	300
81	Registration/cancellation confirmed	0	0	0	0	0
82	Redirection active	0	0	0	0	0
83	Redirection inactive	0	0	0	0	0

LEGEND:

- NOR - Number of retries (to reestablish connection)
- TBR - Time (in seconds) between retries
- TBD - Time (in seconds) before disconnect (wait for network to respond or clear)
- DCE - Data circuit-terminating equipment

Table 2-5. Applicability of CPSTB Macroinstruction and Its Operands

Macro: CPSTB	ICAM Network Type and Kind of Program Supported										
	Direct Data Interface		Dedicated Networks			Global Networks					
Operand Name	DDI	RBP	TCI (IMS)	STDMCP	CMCS (COBOL)	STDMCP	TCI (IMS)	COBOL	DMI	DCA	Public Data Networks
	NTR										
*CPSTB	-	-	-	-	-	-	-	-	-	-	0
label	-	-	-	-	-	-	-	-	-	-	R
CPS=	-	-	-	-	-	-	-	-	-	-	R
NOR=	-	-	-	-	-	-	-	-	-	-	0
TBR=	-	-	-	-	-	-	-	-	-	-	0
TBD=	-	-	-	-	-	-	-	-	-	-	0
END=	-	-	-	-	-	-	-	-	-	-	0

*Shows macro applicability

LEGEND:

R = Required O = Optional - = Not applicable

Operands

CPS=

Specifies the 2-character identification number of the desired call progress signal.

CPS=n

Specifies a single call progress signal to be handled by ICAM according to the parameters specified in this macro.

CPS=(n₁, n₂, n_n)

Specifies a series of call progress signals to be handled according to the parameters specified in this macro.

NOR=slca-nor

Specifies the number of times (0-63) the single line communications adapter (SLCA) shall attempt to reestablish a connection to the remote data terminal equipment. Zero is the default.

NOR=icam-nor

Specifies the number of times the ICAM system shall attempt to reestablish a connection if the SLCA fails to reconnect. The range is 0 to 32,767. Zero is the default.

TBR=slca-tbr

Specifies the time in seconds (0-255) between retries by the SLCA to reestablish a connection to a remote data terminal equipment. Zero is the default.

TBR=icam-tbr

Specifies the time in seconds (0-254) between retries by ICAM to reestablish a connection to a remote data terminal equipment. Zero is the default.

TBD=time-before-disconnect

Specifies the time in seconds (0-254) that ICAM will wait following a call progress signal where the data terminal equipment is expected to wait (01, 02, 03 in Table 2-4) before terminating the connection to a public data network. Zero is the default.

END=cpstb-symbol

Specifies that this is the last CPSTB macro in a series of one or more CPSTB macros. You must specify the label of the first CPSTB macro.

Example

1

72

```
TABX   CPSTB CPS=03,TBD=60
        CPSTB CPS=21,NOR=(10,0),TBR=(30,0)
        CPSTB CPS=(45,46),NOR=(30,0),TBR=(5)
        CPSTB CPS=61,NOR=(2,10),TBR=(10,60)
        CPSTB CPS=71,NOR=(,10),TBR=(,1800),END=TABX
```

Call Progress Signal	SLCA		TBD	ICAM	
	NOR	TBR		NOR	TBR
03 Connect when free	0	0	60	0	0
21 Number busy	10	30	0	0	0
45 Controlled not ready	5	5	0	0	0
46 Uncontrolled not ready	5	5	0	0	0
61 Network congestion	2	10	0	10	60
71 Long-term network congestion	0	0	0	10	1800

2.7. How to Specify DCP Channel Characteristics (DCPCHNL)

The DCPCHNL macro generates a link vector table that enables ICAM to record and control the Telcon DCP channel activity. One DCPCHNL macro is required for each Telcon front-end processor connected to the System 80 Model 8, 10,15, or 20.

Table 2-6 describes the interface and type of network definition in which you can use this macro. It also details the applicability of each operand in the macro. In the table, the name of the macro is preceded by an asterisk (to distinguish it from its operands).

Format

LABEL	AOPERATIONA	OPERAND
channel - name	DCPCHNL	CNID=channel -number , ID=subchannel -address , REMOTE=destination -node

Label

channel -name

Specifies a 1- to 4-character identifier of the channel connecting OS/3 to the DCP. This name must be the same identifier specified in the LINE operand of the LPORT macro and used in console commands relating to this channel.

Operands

CNID=channel -number

Specifies the channel number in the range of 1-6 as specified in the CACH macro of COMMCT.

Note: 1, 2, 3, 6, and 7 are valid channel numbers for model 8.

ID=subchannel -address

Specifies the control unit address as specified for the reporting line number in the CACH macro of COMMCT. This address is strapped by a customer service engineer into a memory board of the channel interface in the DCP according to your request. Although the value is strapped in hexadecimal, it is specified in decimal for ID= with valid values of 8 to 15.

REMOTE=destination -node

Specifies a 1- to 4-character name for addressing the Telcon front-end processor connected to the System 80 host. The name must be the same as the name field of the Telcon DCPTS statement.

Table 2-6. Applicability of DCPCHNL Macroinstruction and Its Operands

Macro: DCPCHNL	ICAM Network Type and Kind of Program Supported										
Operand Name	Direct Data Interface		Dedicated Networks			Global Networks					
	DDI NTR RPG IDES	RBP	TCI (IMS)	STDMCP	CMCS (COBOL)	STDMCP	TCI (IMS)	COBOL	DMI	DCA	Public Data Networks
*DCPCHNL	-	-	-	-	-	O	O	O	O	O	O
**channel-name	-	-	-	-	-	O	O	O	O	O	O
**CNID	-	-	-	-	-	O	O	O	O	O	O
**ID	-	-	-	-	-	O	O	O	O	O	O
REMOTE	-	-	-	-	-	O	O	O	O	O	O

*Shows macro applicability

**Required if DCPCHNL is specified.

LEGEND:

R = Required O = Optional - = Not applicable

2.8. How to Create Disk Buffering and Disk Queuing Files (DISCFILE)

The DISCFILE macro creates a disk file for use by ICAM. You can specify two types of ICAM disk files:

- You use the DISCFILE macro with the MSGSIZE operand to specify a disk buffering file. This file is required with the transaction control interface. It is not used with the standard interface.
- You use the DISCFILE macro with the FILEDIV operand to specify a disk queuing file. This file is optional with the standard interface or a transaction control interface.

The allocation and uses of ICAM disk files are described in more detail in 4.2. DISCFILE macros should be grouped together following the CCA, BUFFERS, LINE, and TERM macros. In a transaction control interface, the DISCFILE macro must follow the last TERM macro. In a disk queuing network, the first DISCFILE macros must follow at least one PRCS, TERM, VLINE, or PDN macro.

Table 2-7 describes the interface and type of network definition in which you may use this macro. It also details the applicability of each operand in the macro. In the table, the name of the macro is preceded by an asterisk (to distinguish it from its operands).

Format

LABEL	OPERATION	OPERAND
file-name	DISCFILE	{ MSGSIZE=n FILEDIV=n [, THRESH= { MEM }] [, VERIFY=YES] }

Label

file-name

Is a 1- to 7-character name identifying this disk file. This name must match the file name on an LFD statement in your program's job control stream.

Operands

MSGSIZE=n

This operand is required for a disk buffering file and is used only with IMS. Gives the size, in bytes, of the largest input message.

Table 2-7. Applicability of DISCFILE Macroinstruction and Its Operands

Macro: DISCFILE	ICAM Network Type and Kind of Program Supported										
	Direct Data Interface		Dedicated Networks			Global Networks					
Operand Name	DDI	RBP	TCI (IMS)	STDMCP	CMCS (COBOL)	STDMCP	TCI (IMS)	COBOL	DMI	DCA	Public Data Networks
	NTR										
*DISCFILE (disk buffering)	-	-	R	-	-	-	-	-	-	-	-
label	-	-	R	-	-	-	-	-	-	-	-
MSGSIZE=	-	-	R	-	-	-	-	-	-	-	-
*DISCFILE (disk queueing)	-	-	O	O	O	O	O	O	-	O	O
label	-	-	R	R	R	R	R	R	-	R	R
FILEDIV=	-	-	R	R	R	R	R	R	-	R	R
THRESH=	-	-	O	O	O	O	O	O	-	O	O
VERIFY=	-	-	O	O	O	O	O	O	-	O	O

*Shows macro applicability

LEGEND:

R = Required O = Optional - = Not applicable

FILEDIV=n

This operand is required for a disk queuing file and is used with a standard interface or transaction control interface. It gives the percentage of disk queuing space to be allocated for a control area. There are two ways you can determine the percentage to allocate for a control area. In either case, the percentage you specify must equal at least one disk track. If you fail to provide sufficient file space, you will be canceled with an error code of 480.

1. Rule of thumb estimate:

<i>Number of disk buffers</i>	<i>Approximate FILEDIV allocation</i>
Under 300	10-20% (depending on number of queues)
300-1000	5%
1000-3000	3%
Over 3000	1-2%

Note: If you allocate only one cylinder for the disk queuing file, specify at least 15 for FILEDIV.

2. Calculated percentage:

The control area requires the following:

- one 256-byte sector for every 2000 disk buffers in the file
- one sector for each queue using the file
- one sector for file descriptor records

Use the following formula to calculate the percentage:

$$\text{FILEDIV \%} = \frac{\text{\# sectors needed for control area}}{\text{total \# sectors in file}}$$

Example 1 (large file): Assume that buffer size is 128 words, or 512 bytes, the size of two sectors. This means that a file holding 5000 disk buffers is 10,000 sectors in size. (See 4.2 for information on determining file size.)

File holds 5000 buffers: 5000/2000 (rounded up) =	3 sectors
24 queues use the file =	24 sectors
Needed for file descriptor records =	1 sector
Number of sectors needed	28 sectors
Size of file	10,000 sectors

$$28/10,000 \text{ (rounded up)} = 1\%$$

Example 2 (small file): Assume that buffer size is 64 words, or 256 bytes, the same size as a sector. The file holds 140 disk buffers and is 140 sectors in size.

File holds 140 buffers: 140/2000 (rounded up) =	1 sector
10 queues use the file =	10 sectors
Needed for file descriptor records =	1 sector
<hr/>	
Number of sectors needed	12 sectors
Size of file	140 sectors

12/140 (rounded up) = 10%

Note: If the number of sectors needed is equivalent to less than one cylinder of your disk volume, allocate one cylinder and specify at least **FILEDIV=15**.

THRESH=

Enables ICAM to operate main memory queuing and disk queuing interchangeably, depending on the availability of inactive network buffers.

THRESH=MEM

Specifies that ICAM should use the threshold value calculated at network generation time to determine the mode of operation (main memory queuing or disk queuing). ICAM derives the value from the threshold on the **BUFFERS** macro.

THRESH=m

Specifies the value for ICAM to use in determining the mode of operation. If the number of inactive network buffers equals *m*, disk queuing is initiated. The suggested value is approximately 20 per cent of the number of buffers declared on the **BUFFERS** macro.

Examples:

```
disc-f1 DISCFILE FILEDIV=10,THRESH=MEM
disc-f2 DISCFILE FILEDIV=15,THRESH=30
```

VERIFY=YES

Specifies verification or parity checking of each block written to a disk queuing file. Include this operand if you must be certain that messages written to the disk queuing file are complete and accurate.

Examples

The following are examples of **DISCFILE** macros.

1

72

```
BUFFILE DISCFILE MSGSIZE=1024
DQFILE DISCFILE FILEDIV=10,VERIFY=YES
```

2.9. How to Create Distribution Lists (DLIST)

This macro enables you to specify a static list of message destinations within your network definition. An output request that references a DLIST is the equivalent of multiple output requests that reference every destination in the DLIST. The destinations you specify may include process files, LOCAP files, terminals, or other DLISTs. Specified DLISTs cannot themselves contain DLISTs. A DLIST created within a network is unchangeable for the life of the network.

Table 2-8 describes the interface and type of network definition in which you may use this macro. It also details the applicability of each operand in the macro. The first line in the table is the name of the macro itself preceded by an asterisk (to distinguish it from its operands).

Format

LABEL	ΔOPERATIONΔ	OPERAND
*dl ist-name	DLIST	destination1,destination2,...

Label

dl ist-name

Is a 1- to 4-character name you assign to this distribution list.

Operands

destination1,destination2,...

Identify at least two destinations, which may be process files, locap files, other distribution lists, or terminals.

Notes:

1. You can incorporate DLIST macros in your communications user program; however, you must include at least one DLIST macro (with two valid destinations) into your network definition. You must do this, even if you don't use it. This is to incorporate DLIST processing code into ICAM at system generation time.
2. A destination name may only appear once in a DLIST or a group of DLISTs in the scope of a PUTCP request, or a message processing routine ROUTE macro.
3. Unpredictable results occur if a DLIST is used to send output to an auxiliary device not on line.
4. You cannot nest a DLIST more than once; in other words, a DLIST referenced by a DLIST cannot reference a third DLIST.

Table 2-8. Applicability of DLIST Macroinstruction and Its Operands

Macro: DLIST	ICAM Network Type and Kind of Program Supported										
	Direct Data Interface		Dedicated Networks			Global Networks					
Operand Name	DDI	RBP	TCI (IMS)	STDMCP	CMCS (COBOL)	STDMCP	TCI (IMS)	COBOL	DMI	DCA	Public Data Networks
	NTR										
	RPG										
	IDES										
*DLIST	-	-	O	O	R	O	O	R	-	O	O
label	-	-	R	R	R	R	R	R	-	R	R
dest-1	-	-	R	R	R	R	R	R	-	R	R
dest-2	-	-	R	R	R	R	R	R	-	R	R
dest-n	-	-	O	O	O	O	O	O	-	O	O

*Shows macro applicability

LEGEND:

R = Required O = Optional - = Not applicable

Example

The following example shows the use of three DLIST macros. Note that the first line references the other two distribution lists. Also, no destination name is duplicated in the three macros.

1

72

```
DLT1    DLIST TER1,TER2,DLT2,PFL1,PFL2,DLT3
DLT2    DLIST TER3,PFL3,LOC1,LOC2
DLT3    DLIST TER4,LOC3
```

2.10. How to Indicate the End of Your Network Definition (ENDCCA)

This macro indicates the end of a network definition.

Format

LABEL	ΔOPERATIONΔ	OPERAND
not used	ENDCCA	not used

2.11. How to Specify an End User Profile (EUP)

This macro generates a profile containing the criteria used by the ICAM message format editing facility (format edit) to edit output messages.

Table 2-9 describes the interface and type of network definition in which you may use this macro. It also details the applicability of each operand in the macro. The first line in the table is the name of the macro itself preceded by an asterisk (to distinguish it from its operands).

Format

LABEL	OPERATION	OPERAND
[symbol]	EUP	PRFN=profile-number, ,EUF= { DCT TTY U64 U80 ((lw[,lines][,RET]) } [,EDT=char] [,ETB=(ch ₁ [,ch ₂][,ch ₃)] [,CMWO=YES]

Operands

PRFN=profile-number

Assigns a number to this profile and associates it with an assignment in one related TERM macro. For example, if you identify this profile as 5 (PRFN=5), then you must specify PROFIL=5 in the associated TERM macro that uses it. This number must be unique in your network definition, even if an identical profile definition is used with another terminal.

EUF=

Describes the page and line profile created.

EUF=DCT

Establishes a line width of 132 characters and 54 lines per page for the DCT 500 series and DCT 1000 terminals.

EUF=TTY

Establishes a line width of 72 characters for teletypewriter terminals. There is no limit on the number of lines per page (continuous).

Table 2-9. Applicability of EUP Macroinstruction and Its Operands

Macro: EUP	ICAM Network Type and Kind of Program Supported													
Operand Name	Direct Data Interface		Dedicated Networks			Global Networks								
	DDI	RBP	TCI (IMS)	STDMCP	CMCS (COBOL)	STDMCP	TCI (IMS)	COBOL	DMI	DCA	Public Data Networks			
												NTR	RPG	DES
*EUP	-	-	O	O	O	O	O	O	-	-	-			
label	-	-	R	R	R	R	R	R	-	-	-			
EUF=	-	-	R	R	R	R	R	R	-	-	-			
DCT	-	-	O	O	O	O	O	O	-	-	-			
TTY	-	-	O	O	O	O	O	O	-	-	-			
U64	-	-	O	O	O	O	O	O	-	-	-			
U80	-	-	O	O	O	O	O	O	-	-	-			
EDT=	-	-	O	O	O	O	O	O	-	-	-			
ETB=	-	-	O	O	O	O	O	O	-	-	-			
CMWO=	-	-	O	O	O	O	O	O	-	-	-			
PRFN=	-	-	R	R	R	R	R	R	-	-	-			

*Shows macro applicability

LEGEND:

R = Required O = Optional - = Not applicable

EUF=U64

Establishes a line width of 64 characters for UNISCOPE terminals.
There is no limit on the number of lines displayed (continuous).

EUF=U80

Establishes a line width of 80 characters for UNISCOPE terminals.
There is no limit on the number of lines displayed (continuous).

When one of these EUF options (DCT, TTY, U64, or U80) is specified, format editing avoids splitting contiguous character strings by scanning each line *from right to left* for a character specified in the EDT operand. If one is found, the data to the left is output as a line. If no EDT character is specified, the space character (40¹⁶) is used. DICE sequence characters are not included in the line width count. If you never want a line to be broken, you can specify an EDT character that you know will never be found.

EUF=(lw[,lines][,RET])**lw**

Specifies the number of characters sent in a single line. It may be specified with or without the *lines* subparameter and is used to specify line widths different than those already discussed.

When *lw* is used in conjunction with the ETB or EDT operands, output is transmitted when any of the arguments are satisfied. Note that when you specify *lw*, any DICE character sequences are included in the line width count.

lines

Specifies the number of lines output before format edit inserts a home paper DICE sequence or returns control to your program. Home paper occurs after the number of lines specified, regardless of the number of messages it takes to reach the value. If you do not specify the RET suboperand, a home paper DICE is issued when the *lines* suboperand is satisfied. This suboperand cannot be specified without the *lw* suboperand.

RET

Returns control to your program after the number of lines specified in the *lines* suboperand are sent. The output delivery notice request feature must be specified in your network definition.

If a message contains additional data after the number of lines specified has been sent, the additional data is lost. No notice of this is sent to your program.

When this option (EUF=(lw [,lines] [,RET])) is specified, format editing avoids splitting contiguous characters by scanning each line *from left to right* for a character specified in either the EDT or ETB operands. If both an EDT and ETB character are found, the EDT character gets the priority. If neither is specified, the *lw* parameter takes precedence.

EDT=char

Specifies a single hexadecimal character used as follows:

- To determine the length of an output line. When *lw*, ETB, and EDT operands are used in combination, line composition ends when one of the operands is satisfied.
- As a line editing argument when EUF=DCT, EUF=TTY, EUF=U64, or EUF=U80 is specified. After the line is initially composed according to the line width for the terminal specified, editing scans from right to left to avoid splitting contiguous characters between output lines. If EDT is not specified, editing scans for a space character, hexadecimal 40.
- When specified as 10, it may be used in conjunction with ETB to identify a 4-character DICE sequence for determining the length of a line. The 4-character sequence is never transmitted.

Note: The EDT operand must be specified in hexadecimal without an X or surrounding apostrophes. For example, X'05' would be 05.

ETB=(ch₁[, ch₂][, ch₃])

Specifies a 1- to 3-character hexadecimal sequence that indicates the end of a line in addition to or instead of the character defined in the EDT operand or the *lw* suboperand. Format edit searches each message from left to right, and when an ETB sequence is found, the line is sent to the terminal. The ETB sequence that was found in the message is not sent. Note that this operand may only be specified when the *lw* suboperand is specified.

Note: The ETB operand must be specified in hexadecimal without an X or surrounding apostrophes. For example, X'05' would be 05.

CMWO=YES

Causes the computer message waiting sentinel present in an output message not to be transmitted. This enables a message to be displayed at certain terminals without operator intervention.

Programming Notes

1. Each EUP macro must immediately follow its associated TERM macro in your network definition.
2. Format edit deletes all characters specified by EDT and ETB operands. Program-generated data not specified as editing parameters are forwarded to the device handler.
3. When using format edit to break a message into lines addressed to the DCT 1000, you must observe a maximum line width of 132 characters. You do this by either specifying a line width of 132 or less, or by specifying an editing argument that occurs before the limits are reached.

4. DICE sequences found in a message that you specified by EDT and ETB operands are discarded and are not sent to the terminal.
5. Format edit automatically retries output messages in case of trouble. If it can't transmit a message, it returns the status to ICAM, and ICAM reissues the entire message. (You may get a reprint of several lines already successfully delivered.)
6. Each EUP macro profile must relate to only one TERM macro.
7. When the EUF=DCT, TTY, U64, or U80 parameter is specified and a line contains more than one EDT character, only the first EDT character encountered is recognized as a line delimiter and is deleted. Other EDT characters on a line scanned from right to left are printed out as text characters.

Examples

The following six examples illustrate the use of the EUP macro. It is assumed that the PROFIL operand in the related TERM macro is 1.

Example 1: This example assumes the values supplied by the macro for EUF=DCT are adequate. The format edit routine attempts to avoid splitting contiguous character strings by searching for a space character, from right to left, after generating a line width of 132 characters. After 54 lines are transmitted, a home paper control sequence is transmitted and output continues.

```
EUP PRFN=1,EUF=DCT
```

Example 2: This example is the same as example 1, except that lines are constructed on the basis of 132 characters or on the occurrence of the first FF 16 character. The FF is not transmitted.

```
EUP PRFN=1,EUF=DCT,EDT=FF
```

Example 3: This example is similar to example 1, except that no attempt is made to avoid splitting of contiguous character strings.

```
EUP PRFN=1,EUF=(132,54)
```

Example 4: This example shows output is 80-character lines. When 16 lines are sent, a home paper sequence is issued.

```
EUP PRFN=1,EUF=(80,16),CMO=YES
```

Example 5: This example is in error. You cannot specify an ETB sequence unless you also specify the *lw* subparameter.

```
EUP PRFN=1,EUF=TTY,ETB=(AA)
```

Example 6: This example shows that 80-character lines are sent to the UNISCOPE terminal. A new line is composed if hexadecimal FF is found. If no FF is found, the EDT parameter is superfluous since the UNISCOPE terminal will block on 80-character lines.

EUP PRFN=1,EUF=U80,EDT=FF

2.12. How to Create Journal Files (JRNFILE)

The JRNFILE macro creates a journal file. During execution of your program, ICAM writes cold restart and report producing records to this file for later processing by the journal utility program (JUST). Refer to 4.4 for a description of journaling and a sample network definition for a system that supports journaling.

Table 2-10 describes the interface and type of network definition in which you may use this macro. It also details the applicability of each operand in the macro. The first line in the table is the name of the macro itself preceded by an asterisk (to distinguish it from its operands).

Format

LABEL	ΔOPERATIONA	OPERAND
filename	JRNFILE	<pre>[TYPE=([SAT] [, { TAPE }])] [,BUFF=(({ number } [, 1024] [, { thresh }]))]</pre>

Label

filename

Is the logical filename. This label identifies the journal file and is required. It is referenced by (and must be identical to) the following:

- the filename operand of the MPPS JOURN macro
- the filename on the LFD statement in the job control stream to execute your communications user program (not the utility program that prints journal reports)

Operands

TYPE=(SAT, DISC)

Journal file is a disk system access technique (SAT) file. Standard labels are assumed.

TYPE=(SAT, TAPE)

Journal file is a tape SAT file. Standard labels are assumed.

Table 2-10. Applicability of JRNFILE Macroinstruction and Its Operands

Macro: JRNFILE	ICAM Network Type and Kind of Program Supported										
	Direct Data Interface		Dedicated Networks			Global Networks					
Operand Name	DDI	RBP	TCI (IMS)	STDMCP	CMCS (COBOL)	STDMCP	TCI (IMS)	COBOL	DMI	DCA	† Public Data Networks
	NTR										
	RPG										
	DES										
*JRNFILE	-	-	O	O	O	O	O	O	-	O	O
label	-	-	R	R	R	R	R	R	-	R	R
TYPE=	-	-	O	O	O	O	O	O	-	O	O
BUFF=	-	-	O	O	O	O	O	O	-	O	O

*Shows macro applicability

†Packet-switched only

LEGEND: R = Required O = Optional - = Not applicable

BUFF= (({ number } [, 1024] [, { thresh }]))

Creates staging areas in which records are constructed for output to the journal file.

number

Number of staging areas required for this file. The permitted values are from 3 to 10; the default is 3. In most cases, 3 staging areas are adequate. You may need more staging areas for a tape journal file or if some of your messages are very large.

1024

Size of each staging area, in bytes.

thresh

Specifies the minimum number of inactive staging areas permitted. The permitted values are from 0 to the number of staging areas specified; the default is 1.

Example

1

72

```
JOURN1  JRNFILE  TYPE=(SAT,TAPE),BUFF=(5,1024,2)
JOURN2  JRNFILE
```

The first JRNFILE macro specifies a tape journal file and allocates five 1024-byte staging areas with a threshold value of 2.

The second JRNFILE macro assumes all default values. The journal file is on disk; three 1024-byte staging areas are allocated, with a threshold value of 1.

2.13. How to Define Local Data Terminal Equipment in a Circuit-Switched Public Data Network (LDTE)

This macro defines the attributes of local data terminal equipment (DTE) in a circuit-switched public data network (PDN).

Table 2-11 describes the interface and type of network definition in which you may use this macro. It also details the applicability of each operand in the macro. The first line in the table is the name of the macro itself preceded by an asterisk (to distinguish it from its operands).

Format

LABEL	OPERATION	OPERAND
symbol	LDTE	[ADDRESS=number] [, INID= { NO } { YES }] [, OUTID= { NO } { YES }] [, CPSTBL=cpstb-name] [, OUTBARD= { NO } { YES }] [, LGROUP= { (m,n) } { (1,0) }]

Label

symbol

Specifies the 1- to 4-character label of this macro.

Operands

ADDRESS=number

Specifies the address (calling number) of this local DTE. This operand is not required but can be used for documentation purposes.

INID=NO

Specifies that incoming calling line identification is not validated.

Table 2-11. Applicability of LDTE Macroinstruction and Its Operands

Macro: LDTE	ICAM Network Type and Kind of Program Supported													
Operand Name	Direct Data Interface		Dedicated Networks			Global Networks								
	DDI	RBP	TCI (IMS)	STDMCP	CMCS (COBOL)	STDMCP	TCI (IMS)	COBOL	DMI	DCA	Public Data Networks			
												NTR	RPG	IDES
*LDTE	-	-	-	-	-	-	-	-	-	-	R			
label	-	-	-	-	-	-	-	-	-	-	R			
ADDRESS=	-	-	-	-	-	-	-	-	-	-	O			
INID=	-	-	-	-	-	-	-	-	-	-	O			
OUTID=	-	-	-	-	-	-	-	-	-	-	O			
CPSTBL=	-	-	-	-	-	-	-	-	-	-	O			
OUTBARD=	-	-	-	-	-	-	-	-	-	-	O			
LGROUP=	-	-	-	-	-	-	-	-	-	-	O			

*Shows macro applicability

LEGEND:

R = Required O = Optional - = Not applicable

INID=YES

Specifies that ICAM is to validate calling line identification for all incoming calls to this local DTE.

OUTID=NO

Specifies no validation of called line identification for outgoing calls.

OUTID=YES

Specifies that ICAM is to validate all called line identification for outgoing calls from this local DTE. The PDN reports the called number to ICAM before making a connection, and this provides a check that the PDN has correctly interpreted the called number.

CPSTBL=cpstb-table-name

Specifies the label (symbol) of the CPSTB macro that defines the call progress signal used for this local DTE. If you do not specify this operand, the defaults specified in Table 2-4, the call progress signal table, are used.

OUTBARD=

This feature is used with DTE intended for incoming calls only. It bars outgoing calls to make the DTE available for receiving calls only. This keyword may be specified only for connections with another computer.

OUTBARD=NO

Specifies that outgoing calls are allowed (not barred) by this local DTE.

OUTBARD=YES

Specifies that outgoing calls are barred by this local DTE, which is available for receiving calls only.

LGROUP= (m,n)

(1,0)

Indicates the number of lines available for this local DTE and the number of these lines that are reserved for receiving calls only. This keyword may be specified only for connections with UTS 20X terminals.

m

Indicates the number of lines in this local DTE; the default is 1; *m* must match the number of CACH macros with the LDTE parameter.

n

Indicates the number of lines in this local DTE reserved for incoming calls; the default is 0; *n* must not be greater than *m*.

2.14. How to Specify Line Characteristics (LINE)

Use the LINE macro to specify the characteristics of each local line in a dedicated or global communications network. These characteristics include:

- the general type of remote device handler needed to support the terminals on the line
- features of the line
- queue arrangements used by terminals on the line

One instruction must be coded for each communications line.

Line queuing (an output option) must not be used in a global network. Therefore, for a global network, do not specify the LOW, MEDIUM, and HIGH keywords in the LINE macro; specify the output queues you need in the appropriate TERM macro.

Table 2-12 describes the interface and type of network definition in which you may use this macro. It also details the applicability of each operand in the macro. The first line in the table is the name of the macro itself preceded by an asterisk (to distinguish it from its operands).

Format

LABEL	ΔOPERATIONAL	OPERAND
line-name	LINE	DEVICE=(DCT475) (DCT500 [, { AUTO }]) [, { TTY }]) (DCT1000, BATCH) (DCT1000[, INTER] [, UNISCOPE]) (DCT2000 [, { 84 }]) [, { 132 }]) (DCT2EM [, { 84 }]) [, { 132 }]) (TTY [, { 33 }]) [, { 35 }]) [, { 37 }]) (TTYEM) (UNISCOPE [, KA]) (1004) (1004EM) (9200) (9300)

continued

LABEL	OPERATIONA	OPERAND
line-name	LINE (cont)	<pre> DEVICE= (BSC, {line-buffer-length} [, {ASCII} [, INTER]] (cont) {216} {EBCDIC} {TRANSCOD} (3271) (INV3271) (LWS,KA) (RWS) (RDHA[,RDHB][,RDHC][,RDHD]) (UTSX) (MAP5RDH) [,TYPE= ([line-speed][,CRTS][,FLDQ][,FULL] [,NIDLE][,SWCH][,SYNC] [, {AUTO}] [,X21] [,UNAT]) [,CALL=phone-number] [,CHAN=channel-number] [,ID=slca-number] [,DIALER=(slca-number,[eon][,prt])] [,INPUT= ({name} [,blanks][,filename] {YES})] [,LBL=line-buffer-length] [,LOW= {filename} {MAIN}] [,MEDIUM= {filename} {MAIN}] [,HIGH= {filename} {MAIN}] [,RDHLQ=YES] [,RECONNECT= {QUEUES} {YES}] [,RETRY=(input-number,output-number)] [,STATS= {NO} {YES}] [,TIMEOUT=(input-time,output-time)] [,XLATE= ({labeli,idi} , {labelo,ido}) ({NO} , {NO}) ({YES} , {YES})] [,CIRCSW=(DATEX,n,m)] [,DESPACE= {U} {Y} {N}] [,CTABLE=(label,PCW,CIT,CDT)] </pre>

Table 2-12. Applicability of LINE Macroinstruction and Its Operands

Macro: LINE	ICAM Network Type and Kind of Program Supported										
	Direct Data Interface		Dedicated Networks			Global Networks					
Operand Name	DDI	RBP	TCI (IMS)	STDMCP	CMCS (COBOL)	STDMCP	TCI (IMS)	COBOL	DMI	DCA	Public Data Networks
	NTR										
*LINE	R	R	R	R	R	R	R	R	R	O	O
label	R	R	R	R	R	R	R	R	R	R	R
CALL=	O	O	O	O	O	O	O	O	O	O	O
CHAN=	O	O	O	O	O	O	O	O	O	O	O
CIRCSW=	O	O	O	O	O	O	O	O	O	O	O
CTABLE=	O	O	O	O	O	O	O	O	O	O	O
DESPACE=	-	-	-	-	-	-	-	-	O	O	O
DEVICE=	R	R	R	R	R	O	R	R	R	R	R
DIALER=	O	O	O	O	O	-	O	O	O	O	O
HIGH=	-	-	O	O	O	O	-	-	-	-	-
ID=	O	O	O	O	O	O	O	O	O	O	O
INPUT=	-	-	O	O	O	-	O	O	O	O	O
LBL=	O	O	O	O	O	-	O	O	O	O	O
LOW=	-	-	O	O	O	-	-	-	-	-	-
MEDIUM=	-	-	O	-	O	O	-	-	-	-	-
RDHLO=	-	-	-	O	-	O	-	-	-	-	-
RECONNECT=	O	-	O	O	O	-	-	-	-	-	-
RETRY=	O	O	O	O	O	O	O	O	O	O	O
STATS=	O	O	O	O	O	R	O	O	O	O	O
TIMEOUT=	O	O	O	R	O	O	O	O	O	O	O
TYPE=	R	R	R	O	R		R	R	R	R	R
XLATE=	O	O	O		O		O	O	O	O	O

*Shows macro applicability

LEGEND:

R = Required O = Optional - = Not applicable

Label

line-name

Is a 1- to 4-character label that identifies this line.

Operands**DEVICE=**

Identifies the devices connected to this line and their mode of operation, if applicable. ICAM includes the appropriate remote device handler based on this specification. You may also specify a user-written remote device handler with this operand. Suboperands must be coded in the order shown; code a comma for any omitted.

DEVICE=(DCT475)

Identifies a DCT 475 Data Communications Terminal.

DEVICE=(DCT500,AUTO)

Identifies one or more DCT 500 or DCT 524 Data Communications Terminals operating in automatic mode. (In automatic mode, these terminals can be mixed on a line.)

DEVICE=(DCT500,TTY)

Identifies a DCT 500 or DCT 524 terminal operating in teletypewriter mode.

DEVICE=(DCT1000,BATCH)

Identifies a DCT 1000 Data Communications Terminal operating in batch mode.

DEVICE=(DCT1000,INTER)

Identifies one or more DCT 1000 terminals operating in interactive mode.

DEVICE=(DCT1000,INTER,UNISCOPE)

Identifies a combination of one or more DCT 1000 terminals operating in interactive mode and one or more of the following terminals:

- UNISCOPE 100 or UNISCOPE 200 Display Terminals
- UTS 400 Universal Terminal System, operating in UNISCOPE mode, UTS 400 native mode, or UTS 4000 in UTS 400 mode
- UTS 400 Universal Terminal System Text Editors
- UDS 2000 Universal Distributed System in UNISCOPE mode

DEVICE=(DCT2000,{~~84~~
132})

DCT2000

Identifies a DCT 2000 Data Communications Terminal.

~~84~~ or 132

Is the line buffer length in bytes. This specification must correspond to the print line length specified for this device in the FEATURES operand of the TERM macro. If 84 is specified (or defaulted) for line buffer length, 80 must be specified (or defaulted) for print line length; if 132 is specified for line buffer length, 128 must be specified for print line length.

DEVICE=(DCT2EM,{~~84~~
132})

DCT2EM

Indicates that this line supports a System 80 emulating a DCT 2000 Data Communications Terminal.

~~84~~ or 132

Is the line buffer length in bytes.

DEVICE=(TTY,33), DEVICE=(TTY,35), or DEVICE=(TTY,37)

Identifies a TELETYPE[®] Model 33, 35, or 37 teletypewriter using ASCII code.

Note: For the UTS 10 teletypewriter model single-station display terminal, specify DEVICE=(TTY).

DEVICE=(TTYEM)

Indicates that this line is emulating a full-duplex, uncontrolled, TTY-like device. Specify this parameter for an OS/3 to UNIX[®] O/S connection through an asynchronous line. (The System 80 appears to the UNIX O/S as an asynchronous terminal.) When you specify this option, you must specify FEATURES=(TTYEM) on the TERM macro. You may specify only one TERM macro for each TTYEM line.

DEVICE=(UNISCOPE)

Identifies one or more of the following Unisys terminals or terminal systems:

- UNISCOPE 100 or 200
- UDS 2000 operating similar to a UNISCOPE terminal

TELETYPE is a registered trademark of Teletype Corporation.
UNIX is a registered trademark of AT&T Information Systems.

- UTS 400 operating similar to a UNISCOPE terminal or UTS 400 native mode
- UTS 400 text editor
- UTS 4000 Universal Terminal System
- UTS 20, UTS 30, UTS 40, PC, SVT 1120, SVT 1123, SVT 1124
- UNIX O/S using UNISCOPE emulation through the Programmable Communications Controller
- V77 Series Data Processing System emulating a UNISCOPE 100 terminal

DEVICE=(UNISCOPE,KA)

Identifies one or more UTS 400/4000 Universal Terminal System terminals that utilize Katakana/English keyboards. Applies only to terminals operating in native mode.

DEVICE=(1004)

Identifies a 1004 Card Processor operating under control of an RMS1 plugboard.

DEVICE=(1004EM)

Indicates that this line supports a System 80 emulating a 1004 Card Processor.

DEVICE=(9200)

Identifies a 9200 Data Processing System (using REM-1 protocol) that is emulating a 1004 Card Processor operating under the control of an RMS1 plugboard.

DEVICE=(9300)

Identifies a 9300 Data Processing System (using REM-1 protocol) that is emulating a 1004 Card Processor operating under the control of an RMS1 plugboard.

DEVICE= (BSC, {line-buffer-length} [216], {ASCII
EBCDIC
TRANSCOD} [, INTER])

BSC

Identifies a binary synchronous communications controlled device. Must be specified for:

- IBM[®] 2780 or 3780 terminals

IBM is a registered trademark of International Business Machines.

- 3741 Data Communications terminals
- UDS 2000 emulating IBM 2780 or 3741 terminals
- UNIX O/S emulating IBM 2780/3780 terminals

line-buffer-length

Specifies line buffer length in bytes. Calculate as follows:

$2m + mn$ for nontransparent mode

$4m + mn$ for transparent mode

where:

m = number of records per block

n = number of data characters per record

If line-buffer-length is omitted, a default line buffer length of 216 is assumed.

ASCII

Indicates messages are in ASCII code.

EBCDIC

Indicates messages are in EBCDIC code. The UDS 2000 (emulating an IBM 2780/3741) uses EBCDIC code.

TRANSCOD

Indicates messages are in TRANSCODE code. Transcode is not valid for IBM 2780EM or 3780EM.

INTER

Specifies a message-oriented CPU-CPU BSC connection for IMS and TIP30 users only. This specialized remote device handler is designed for inquiry/response to data bases in another CPU (not file transfers).

Line-buffer-length must exceed the largest output message or input block by 4 bytes. Each output message is sent as a message (ETX), while input continuation segments (ETB) are assembled into one message up to 32K bytes.

DICE is not supported and a leading DLE will abort an output message. Record separators are not supported or recognized.

IMS/TIP30 control messages and BELs are not sent to another CPU; only data messages are sent.

Normal ICAM batch mode requirements of one record per network buffer do *not* apply.

On the TERM macro, follow the FEATURES=(IBSC...) parameters.

DEVICE=(3271)

Identifies one or more IBM 3270 terminal systems operating in the BSC polling/selecting mode. The IBM 3270 terminal system consists of a 3271 control unit and a 3277 display station. It may optionally have a 3284 printer or a 3286 printer.

DEVICE=(INV3271)

Identifies a 3271 emulator line to an IBM host (IBM 3270 emulator).

DEVICE=(LWS) or DEVICE=(LWS,KA)

Identifies a local workstation (UTS 20D, UTS 40D, or SVT 1122) or a local workstation with Katakana support that is accessed through ICAM. Unless the user specifies translation table substitution, XLATE=(NO,NO) must be specified for local workstations with Katakana support.

UTS 40D and SVT 1122 local workstations have dual-screen support through ICAM. System mode exists on screen 1 only, but data mode input is accepted on both screens 1 and 2. To take advantage of the dual-screen support, two TERM statements must be defined for the LINE.

DEVICE=(RWS)

Identifies a remote workstation. This workstation may be a Unisys Universal Terminal System (UTS 20, UTS 30, UTS 40, PC, SVT 1123, or SVT 1124) as designated by the TERM macro. When you specify this operand, you must also specify DCA=YES and GAWAKE=YES in the CCA macro and a PGROUP macro for each polling group.

DEVICE=(RDHA1, RDHB1I, RDHC1I, RDHD1)

Includes one to four user-written remote device handlers in the ICAM symbiont. You must assemble your handlers prior to network generation, assign RDHA, RDHB, RDHC, or RDHD as its module name, and store it in the SG\$OBJ library on the system resident volume.

DEVICE=(UTSX)

Identifies a line for use with an X.21 circuit-switched PDN for connection to a UTS 20X terminal.

DEVICE=(MAP5RDH)

Specifies this line requires the MAPPER[®] 5 remote device handler to interface with a MAPPER 5 system.

Note that when you specify DEVICE=(MAP5RDH):

- Line buffer length (see LBL operand) is forced to a minimum of 700 *words*
- FEATURES operand on the TERM macro must be specified as FEATURES=(U200,1920...)

TYPE= [line-speed][,CRTS][,FLDQ][,FULL][,NIDLE][,SWCH][,SYNC] , AUTO [,X21]
UNAT

Identifies the characteristics of this line. Table 2-13 lists the TYPE specifications associated with particular line characteristics, plus other required operands. Line-speed, if required, must be the first TYPE suboperand specified. Code a comma if you omit it. The other suboperands may be coded in any order. The TYPE operand is not required for local workstations.

line-speed

Specifies the rate in bits-per-second at which data is exchanged between terminals connected to this line and ICAM.

The speed you specify is used only by the ICAM software to establish an internal buffer; therefore, it need not match the line speed of your line exactly. However, the value you specify must be one of those provided in Table 2-14. In general, the larger the value you specify, the better your performance will be for that line; however, additional main storage would be required. Table 2-15 indicates maximum line speeds in bits per second (bps) for ICAM-supported terminals.

Note: *ICAM does not support switched lines at speeds greater than 9600 bps.*

CRTS

Indicates the request-to-send signal is cleared in output/output message sequences. This inhibits the sync character from being sent.

FLDQ

Specifies 2-way simultaneous queuing. Input and output messages are queued to and from a 2-way simultaneous communications line. For standard (ICAM-supplied) remote device handlers, this feature is available only with NTR and intelligent line adapter (ILA) lines; it can also be used with user-written remote device handlers. If you specify FLDQ, you must also specify FULL.

MAPPER is a registered trademark of Unisys Corporation.

Table 2-13. Line Characteristics and TYPE Specifications

Line Characteristic	TYPE Specifications	Other Operands
Baud rate	line-speed	
Automatic dialing	AUTO, SWCH *	CALL= DIALER= ID=
Operator dialing	SWCH The ID operand is optional.	CALL=
Automatic answering (unattended answering)	SWCH, UNAT	ID=
Dedicated line	Code a comma to override SWCH default	ID=
Two-way simultaneous transmission (full-duplex)	FULL	
Two-way simultaneous transmission for NTR and ILA	FULL, FLDQ	
Two-way simultaneous transmission for TTYEM	FULL, FLDQ	
Two-way alternate transmission (half-duplex)	Default condition	
Synchronous transmission	SYNC	
Asynchronous transmission	Default condition for teletypewriters for other devices, code a comma to override SYNC default	
Request-to-send signal	CRTS	
No line turnaround **	NIDLE	
Automatic line turnaround (for half-duplex synchronous line)	Default condition	

Notes:

* DATEX-L always requires the specification of both AUTO and SWCH.

** Applies to synchronous, 2-way alternate transmission on UNISCOPE/UTS 400/UTS 4000 terminals only.

Table 2-14. Line-Speed Values

Asynchronous Line Speeds	Synchronous Line Speeds
50	2000
75	2400
110	4800
134	7200
150	9600
300	19200
600	48000
900	56000
1200	
1800	
2400	
3600	
4800	
7200	
9600	

Table 2-15. Maximum Line Speed of ICAM-Supported Terminals

Terminal	Baud Rate (bps)
UNISCOPE 100 and 200 Display Terminals	9600
UTS 20/30/40 Single Station Terminals	9600
UTS 400 Universal Terminal System	9600
UTS 4020/4040 Cluster Controllers	19,200
SVT 1120, SVT 1123, SVT 1124	19,200
DCT 475 Data Communications Terminal	110
DCT 500/524 Data Communications Terminals	300
DCT 1000 Data Communications Terminal	9600
DCT 2000 Data Communications Terminal	2400
UDS 2000 Universal Distributed System	9600
TELETYPE Models 33, 35	110
TELETYPE Model 37	150

continued

Table 2-15. Maximum Line Speed of ICAM-Supported Terminals (cont.)

Terminal	Baud Rate (bps)
UTS 10 Universal Terminal System Single Station in Teletypewriter Mode	9600
IBM 2780 Data Communications Terminal	4800
IBM 3780 Data Communications Terminal	4800
IBM 3270 Data Communications Terminal System	7200
IBM 3741 Data Communications Terminal	9600
UNIX System (500/20, 40, 60, 80 and 7000/40) IBM 2780 or 3780 emulation	4800
UNIX System using PCC for UNISCOPE emulation	19,200
1004/1005 Card Processor	9600
9200/9300 Data Processing System	56K
MAPPER 5	19,200
UNIX System connected to OS/3 via asynchronous line	4800

FULL

Indicates this dedicated line is capable of 2-way simultaneous transmission (full-duplex operation). The ICAM remote device handlers do not operate terminals in this mode (except as described under FLDQ) but can take advantage of this line characteristic to decrease turnaround time. Omit this option for 2-way alternate transmission (half-duplex operation). When this option is specified, the ID keyword must also be specified.

Note: *If an ICAM remote device handler uses 2-way-alternate protocol (half-duplex), the line must be defined as 2-way-alternate also. All ICAM remote device handlers utilize 2-way-alternate protocol except NTR, UDLC, ABM, and level 2 X.25 public data networks.*

If 2-way simultaneous protocol is used, the same protocol must be specified in the ICAM generation (LINE and CACH).

Two-way simultaneous modems and lines may be used with 2-way-alternate protocol, if required.

NIDLE

No automatic line turnaround is desired. Automatic line turnaround prepares the line for output immediately after completion of input. This applies only to a synchronous line with 2-way alternate transmission and UNISCOPE and UTS 400 terminals.

SWCH

Specifies this line is switched. That is, it must be dialed either automatically by the computer or manually by the operator. Switched is the default condition for all devices unless you specify otherwise.

You specify a switched line by specifying the SWCH suboperand. You specify a nonswitched line (dedicated line) by specifying a comma anywhere in the TYPE operand and not specifying SWCH. For example:

`TYPE=(110,),ID=4`

Specifies a dedicated asynchronous line with a line speed of 110, using port 4.

`TYPE=(2400, SYNC)`

Specifies a dedicated synchronous line. Notice the absence of the SWCH suboperand and the presence of a comma and the SYNC suboperand.

SYNC

Specifies this line's hardware is set for synchronous transmission of data.

If you omit the SYNC suboperand, and you have coded a comma anywhere in this operand, asynchronous transmission is assumed. For example:

`TYPE=(2400,),ID=6`

Specifies a dedicated (nonswitched) asynchronous line with a line speed of 2400 baud, using port 6. Notice that a comma was coded in the TYPE operand, and SWCH and SYNC were not specified. The comma causes a default to dedicated and asynchronous.

`TYPE=(2400, SWCH)`

Specifies a switched asynchronous line with a line speed of 2400 baud. Notice that a comma was coded along with the SWCH suboperand. This indicates that asynchronous transmission is required.

`TYPE=(2400, SWCH, SYNC)`

Specifies a switched synchronous line.

AUTO

Indicates this line is equipped for automatic dialing. Applies only to switched lines.

UNAT

Indicates the computer automatically answers incoming calls (unattended answering) from the terminals on this line via the switched telephone network without operator intervention. Applies only to switched lines. Not available if FEATURES=BASIC is specified in the CCA macro.

X21

Indicates this line is used with an X.21 circuit-switched PDN for connection to a UTS 20X terminal. When this option is specified, SWCH must also be specified.

CALL=phone-number

Is a numeric or alphanumeric telephone number used to dial a terminal. Must be specified for either automatic or operator dialing.

In automatic dialing, a hyphen in the phone number causes a 1.1-second pause. This delay is necessary whenever a connection must be made before more dial characters are sent. For example, if you code CALL=6-444-4567 for a tie line, the 6 initiates the first connection of the tie line, then a 1.1 second pause occurs before the next character is sent. After the 444 is sent, another pause occurs allowing that connection to be made before the 4567 is sent. The hyphens are not sent to the automatic calling unit.

For automatic dialing, the maximum number of dialing digits and hyphens in the phone number is 48. For manual dialing, the maximum number is 11. If you specify more, the number is truncated at the console. For security purposes, you could specify a code word to the operator who would then dial the known number.

Note: Do not specify the call operand if you specify unattended answering (UNAT).

CHAN=channel-number

Specifies the input/output microprocessor (IOMP) to which the single-line communications adapter (SLCA) is connected.

For System 80 models 3 through 6, this operand is optional. If specified, the only value permitted is CHAN=2. The default is CHAN=2. Up to eight SLCA's (ID=8 to ID=15) can be specified for these models.

For System 80 models 8 through 20 with one IOMP, this operand is optional. If specified, the only value permitted is CHAN=13. The default is CHAN=13. Up to 14 SLCA's (ID=1 to ID=15) can be specified for the IOMP.

For System 80 models 8 through 20 with two IOMPs, this operand is optional. If specified, you must also specify the ID operand. The only values permitted are CHAN=13 and CHAN=15. Up to 14 SLCA's (ID=1 to ID=15) can be specified for each IOMP.

ID=slca-number

Specifies the address on the input output micro-processor (IOMP) channel where the single-line communications adapter (SLCA) this line uses is connected. The SLCA number is specified in decimal. This SLCA number must match the SLCA number specified in the associated CACH statement.

This operand is required for private lines and switched lines with automatic dialing or unattended answering. (For lines with automatic dialing, you must specify an ID and DIALER operand for the automatic calling unit used. See Figure 2-1.)

For System 80 models 3 through 6, you can specify up to eight SLCA numbers (ID=8 to ID=15).

For System 80 models 8 through 20, you can specify up to 14 SLCA numbers (ID=1 to ID=15) for each IOMP channel. When you specify the ID operand and do not specify the CHAN operand, CHAN defaults to 13.

Whenever you do not specify an ID operand, ICAM assigns an SLCA number based on the requirements specified in the TYPE operand.

DIALER=(slca-number,[eon],prt)

Identifies the location of an automatic dialer. Specify this operand only for lines with automatic dialing by the computer. Figure 2-1 illustrates the way ports are defined on SLCA's and shows how to specify this operand.

slca-number

Specifies the decimal SLCA where the dialer is located. Specify an SLCA number that is not used by any LINE or VLINE macro in this network definition.

eon

Specifies an optional end-of-number character required by some automatic calling units. Refer to the operating instructions for your calling unit to see if it requires one.

prt

Each single-line communications adapter can accept up to three automatic calling units. Specify a decimal number 0, 1, or 2 that identifies the port on the SLCA where the calling unit is installed. If no value is specified, 1 is the default.

Note: Do not specify DIALER if you specify unattended answering (UNAT).

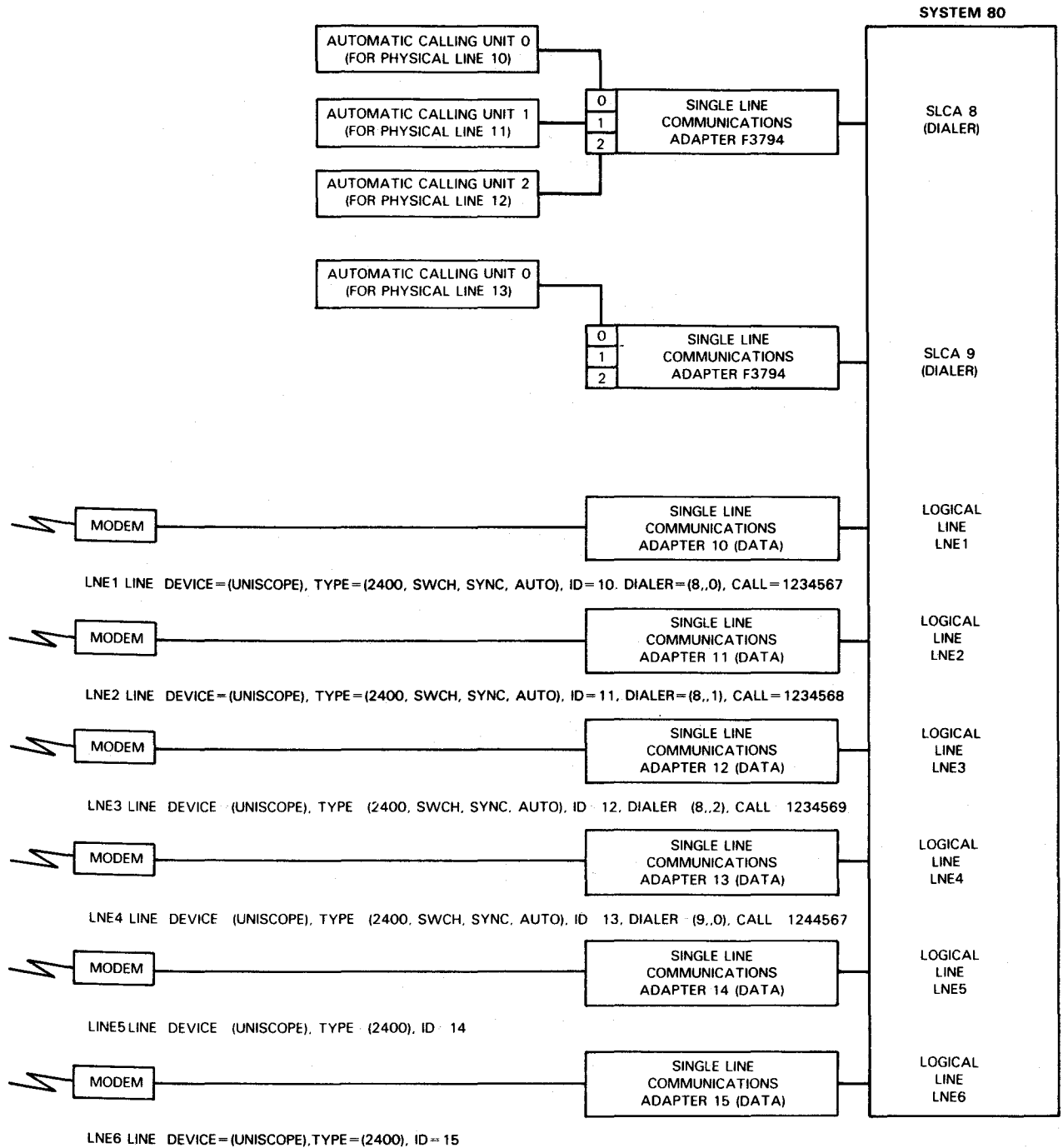

Figure 2-1. How to Specify SLCA Ports Using Automatic Dialing and Leased Lines

INPUT= ({ name } [,blanks] [,filename]
 { YES }

Establishes a destination for input messages for all of the terminals on this line unless overridden by an INPUT operand in a TERM macro.

Note: You must specify this operand for all terminals on this line - either here or in a TERM macro.

name

Is a 1- to 4-character name that matches the label field of a LOCAP, PRCS, MPPS, or TERM macro. This is the name you address on GETCP calls to a process file or to a LOCAP file to retrieve input messages from a terminal. Depending on the *name* you specify, input messages from all terminals on this line are directed to one of the following:

- the low priority queue of a user program defined by the label of a LOCAP macro (global networks only).
- the low priority queue of a process file, defined by the label of a PRCS macro.
- the low priority queue of a terminal, defined by the label of a TERM macro (this causes message switching because a message, input from a terminal on this line, is immediately placed on the output queue of another terminal).
- a destination determined by an MPPS routine, with the name of the routine defined by the label of an MPPS macro. An MPPS routine is the only input destination you can specify if you use the transaction control interface.

YES

Automatically creates an input message queue for *each* terminal on this line. If you also include the *filename* suboperand, input messages are held in a disk file until your program accesses them. If you omit *filename*, main storage input message queues are established.

Your program accesses a message placed on one of these queues by issuing a GETCP macro and, in the related DTFCP, specifying the label of the appropriate TERM macro. You need not specify a priority.

This suboperand is not supported for the transaction control interface.

blanks

Is a decimal value from 1 to 255 indicating the number of bytes you want reserved in front of each input message for message processing routine (MPPS) or your program's insertion of data.

filename

Is a 1- to 7-character name of a disk file where input messages from terminals on this line are stored until your program accesses them. The *filename* must match the label of a DISCFILE macro. Include this suboperand only if you also specify YES.

LBL=line-buffer-length

Is a decimal number that specifies line buffer length in words (one word equals four bytes). Do not include this operand for 1004, 9200/9300, DCT 2000, or NTR. For UNISCOPE-type lines, the maximum value is 1024 words. For IBM 3270, this keyword is ignored and a 65-word line buffer is generated.

For local workstation terminals, line buffer length must be at least the size of your largest message (including format information). If you do not specify this operand, the default value is 600.

For a local workstation emulating an IBM 3270 terminal, specify 1200 to prevent truncation of large messages from the IBM host.

For dual-screen local workstations (UTS 40D and SVT 1122), two line buffers of equal size are generated. This allows data mode input and output to be processed on both screens. For example, if you specify LBL=900, two 900-word buffers are generated.

For remote workstations, DEVICE=(RWS), omit the LBL operand. A default value of 4 words is generated. Be sure to specify the UDUCT and LINKPAK parameters on the BUFFERS macro.

For a line connected to a MAPPER 5 system (DEVICE=(MAP5RDH)), specify at least 700 words. If you do not specify this operand or you specify a value less than 700 words, it defaults to 700 words.

For full-duplex, uncontrolled TTY emulation (you specified DEVICE=(TTYEM)), the default value is 64 words.

For all other devices, if you omit LBL, the following default values are generated, based on your line-speed specification in the TYPE parameter:

Line Speed (maximum baud rate)	Default Value (words)
Up to 2400	20
From 2401 to 4800	40
From 4801 to 9600	80
From 9601 to 19200	160

LOW=filename

Creates a low priority output queue for this line on a disk file you name in a DISCFILE macro.

LOW=MAIN

Creates a low priority output queue for this line in main storage.

MEDIUM=filename

Creates a medium priority output queue for this line on a disk file you name in a DISCFILE macro.

MEDIUM=MAIN

Creates a medium priority output queue for this line in main storage.

HIGH=filename

Creates a high priority output queue for this line on a disk file you name in a DISCFILE macro.

HIGH=MAIN

Creates a high priority output queue for this line in main storage.

Note: If you omit the LOW, MEDIUM, and HIGH operands, a low priority output queue is created in main storage for this line (except when specifying global networks). If you specify any LOW, MEDIUM, or HIGH operand in a TERM macro, it overrides this macro for that terminal only, and a terminal output queue is created. Line queuing must not be specified for global networks.

RDHLQ=YES

Allows a message to be sent to a terminal while a previous message sent to another terminal on this multistation line is being transferred to an auxiliary device. This operand is applicable to user-written remote device handlers only. When it is included, terminal queuing must be specified for each terminal on this line.

RECONNECT=

Provides immediate logical reconnection of unattended (call-in) lines when the original caller disconnects. ICAM does not notify your program or the operator console of the reconnection; however, a LINE DOWN message is sent to the console if the reconnection fails. This keyword is valid only in a dedicated network.

Note: Do not specify the RECONNECT operand for local workstations (DEVICE=(LWS)).

RECONNECT=QUEUES

All output queues, including INTERCEPT, are cleared before reconnection.

RECONNECT=YES

Output queues remain intact at reconnection; next caller receives queued output.

RETRY=(input-number,output-number)

Number of retries before ICAM marks a terminal down and polls it at a slower rate (slow-polling). Input-number and output-number values range from 1 to 255.

input-number

Number of times the remote device handler resends a poll because of an error (such as parity errors or time-out).

output-number

Number of times the remote device handler tries to send a particular output message.

For binary synchronous communication (BSC) devices, input retries apply only to the host bidding for the line. All other retries are considered output retries. For DCT 2000, both input and output retries are determined by the output-number value.

The REPLY operand does not apply to local workstation terminals, DCT 475, DCT 500/524, UTS 10, or TELETYPE. If omitted for other devices, the following default values are generated:

Device Type	Input	Output
BSC	6	4
UNISCOPE/DCT 1000	6	4
DCT 2000	-	4
1004/9200/9300	6	4
IBM 3270	4	6
IBM 3270 Emulator	6	4
RWS	6	4

LINE

STATS=NO

Terminal statistics are not accumulated for this line.

STATS=YES

Terminal statistics are accumulated for each terminal on this line. The TN#TSTAT field of each terminal control table (covered by the TN#TCT dummy control section) gives the relative address of the statistics area for that terminal. The following is the format of the 3-word statistics area:

WORD	0	1	2	3	BYTE
1	Number of messages received		Number of input retransmission requests		
2	Number of messages transmitted		Number of output retransmission requests		
3	Number of polls sent		Number of no-traffic responses		

For a local workstation, the number of polls sent is the number of read instructions that were issued. The number of no-traffic responses is the number of times a read instruction was canceled because an output message was sent before input data was received.

TIMEOUT=(input-time,output-time)

Time-out values, in seconds, for input and output messages. Input-time and output-time range from 1 to 255. If time-out occurs, ICAM retries the number of times specified in the RETRY operand. No retries are made for DCT 500/524, UTS 10, or TELETYPE. This operand does not apply to local workstation terminals.

input-time

The number of seconds in which terminals on this line must respond to polls or fill one of the line's pair of line buffers.

For binary synchronous communications (BSC) controlled devices, the input-time value is used when input text is expected or during receipt of input text. For DCT 500/524 and TELETYPE, this value applies to input text after the first input text character is received.

output-time

The number of seconds in which terminals on this line must acknowledge receipt of a message sent by the host processor. This operand does not apply to local workstation terminals.

If timeout values are omitted for other devices, the following default values are generated:

Device Type	Input	Output
BSC	3	20
UNISCOPE/DCT 1000/ UTS 400/UTS 4000	3	20
DCT 500/524/TTY/UTS 10	512	20
DCT 2000	9	20
1004/9200/9300	4	20
IBM 3270	3	20
IBM 3270 Emulator	300	3
RWS	3	20

Note: The TIMEOUT operand is ignored by the 3270 emulator and should not be specified.

$$XLATE = \left(\left(\begin{array}{l} \text{label } i, \text{idi} \\ \text{NO} \\ \text{YES} \end{array} \right) , \left(\begin{array}{l} \text{label } o, \text{id}o \\ \text{NO} \\ \text{YES} \end{array} \right) \right)$$

Determines what translation tables, if any, are used for I/O on this line. If omitted, standard ICAM translation tables are used for both input and output. This operand is overridden for a specific terminal if an XLATE operand is included for that terminal in the TERM macro. (For a discussion of how to generate translation tables, see 4.5.) For IBM 3270 terminal systems and/or local workstations with Katakana support, specify XLATE=(NO,NO). See DEVICE=(LWS,KA).

label i

Is the name of a user-supplied input translation table. It must correspond to the label of a translation table generated in this network definition. You may name the same input translation table in any number of LINE and TERM macros.

idi

Is a decimal number, 1 to 240, further identifying the translation table named in the *label i* suboperand. The *idi* numbers provide an index to the addresses of input translation tables. You should use a different number for each *label i* name; if you use the same number with more than one *label i* name, only the last *label i* name is used.

NO
Input from devices on this line is not translated.

YES
Standard ICAM translation table is used for input from devices on this line.

labelo
Is the name of a user-supplied output translation table. It must correspond to the label of a translation table generated in this network definition. You may name the same output translation table in any number of LINE and TERM macros.

ido
Is a decimal number, 1 to 240, further identifying the translation table named in the *labelo* operand. This number provides an index to the addresses of output translation tables. You should use a different number for each *labelo* name; if you use the same number with more than one *labelo* name, only the last *labelo* name is used.

NO
Output to devices on this line is not translated.

YES
Standard ICAM translation table is used for output to devices on this line.

Note: *The idi and ido suboperands index separate input and output tables; that is, you can have up to 240 input tables and 240 output tables and you can duplicate idi and ido values. You should assign consecutive numbers, starting with 1, to save main storage space.*

CIRCSW=(DATEX,n,m)
Specifies a logical connection of one or more physical links (lines) to a DATEX-L circuit-switched public data network.

where:

n
Is the number of physical lines connected to the network.

m
Is the number of lines dedicated to incoming calls.

Notes:

1. *When specifying the CIRCSW parameter, the keyword parameter DIALER= must also be specified.*

2. When specifying this parameter, the value specified by the ID= keyword represents the first physical line in a group of circuit-switched lines. The remaining lines in the group must be on succeeding ascending ports. This applies also to the DIALER= keyword:

```
LINE CIRCSW=(...,3,0), ID=4, DIALER=(10)
```

For example, the following is a typical hardware configuration:

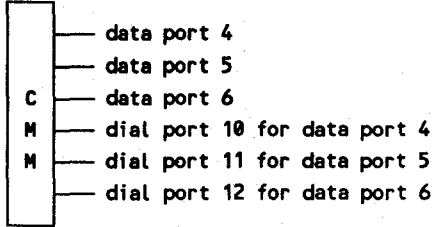

DESPACE=

Specifies the action to be taken by ICAM or interactive services for loading the destructive space specification of the control page. This parameter only applies to remote workstations, UNISCOPE terminals, and UNISCOPE-like devices attached to a DCP.

DESPACE=U

The destructive space parameter is not to be altered (that is, it remains set as previously specified in the control page). This is the default value.

DESPACE=Y

The destructive space parameter is set each time ICAM or interactive services loads the control page.

DESPACE=N

The non-destructive space parameter is set each time ICAM or interactive services loads the control page.

Note: The release 12.0 enhancement for ICAM destructive space definition is restricted for use by terminals located on a cluster controller, which are not loaded with the correct ICAM gen specification for DESPACE=U/Y/N. To obtain the desired destructive space setting, you must manually change the control page specification or use the interactive services SCREEN command.

CTABLE=(label,PCW,CIT,CDT)

Permits the user to modify any or all of the loadable SLCA-1 or SLCA-2 parameters -- port control word (PCW), character interpret table (CIT), and character detect table (CDT) -- on a per line basis.

label

Name of a user-supplied set of assembler DC statements that specify any or all of the loadable SLCA tables. The first word must be a full-word PCW or a full-word of zeros. The second statement is 16 half-words of the CIT or 16 half-words of zero. The third statement is a 256-byte CDT.

PCW

Specifies the new port control word. If it is not to be changed, insert a full-word of zeros and leave the positional parameter null. If only the port control word is being changed, no other statements are required.

CIT

Specifies a 16 half-word character interpret table. If it is not to be changed, insert 16 half-words of zero and leave the positional parameter null.

CDT

Specifies a 256-byte character detect table. If it is not to be changed, leave the positional parameter null.

For example, to change a character detect table, specify the following:

```
CTABLE=(MYDEF,,,CDT)
```

Prior to the ENDCCA statement, the following would appear:

MYDEF	DC	F'0'	no pcw
	DC	16H'0'	no cit
	DC	XL32'1st 32 char'	1st 32 characters of cdt
	DC	XL32'next 32 char'	2nd 32 characters of cdt
	DC	XL32'next 32 char'	3rd 32 characters of cdt
	DC	XL32'next 32 char'	4th 32 characters of cdt
	DC	XL32'next 32 char'	5th 32 characters of cdt
	DC	XL32'next 32 char'	6th 32 characters of cdt
	DC	XL32'next 32 char'	7th 32 characters of cdt
	DC	XL32'next 32 char'	8th 32 characters of cdt

Example

The following example shows LINE macros.

1		72
LNE1	LINE CALL=6469030, DEVICE=(UNISCOPE), TYPE=(2000,UNAT,SWCH,SYNC), ID=4	X X X
LNE2	LINE CALL=1759030, DEVICE=(TTY,33), TYPE=(110,SWCH)	X X
LNE3	LINE DEVICE=(1004), TYPE=(2400), ID=6	X X
LNE4	LINE DEVICE=(LWS), INPUT=(PRF3)	X

2.15. How to Create a LOCAP File for Global Networks (LOCAP)

This macro creates a local (in this computer) or remote (in a different computer) LOCAP file for programs that use a global network. This includes a public data network environment.

A LOCAP file acts as an intermediary for your program, i.e., messages destined for your program are queued to this LOCAP file by ICAM until your program issues a GETTCP request for them¹. In order to access this LOCAP file (i.e., to be able to issue GETTCPs to it), your program must issue an NATTACH interface macro with the APPS operand specified the same as the label of this macro.

Table 2-16 describes the interface and type of network definition in which you may use this macro. It also details the applicability of each operand in the macro. The first line in the table is the name of the macro itself preceded by an asterisk (to distinguish it from its operands).

Format

LABEL	OPERATION	OPERAND
LOCAP-name	LOCAP	<pre> TYPE= ((STDTCP DMI TCI) [,DUSTERR=INLINE] [,LOW= { MAIN filename }] [,MEDIUM= { MAIN filename }] [,HIGH= { MAIN filename }] [,REMOTE= { node subname, PDN }] [,JOBNAME=jobname] [,JOBINIT=(LOAD,REPORT)] [,IAS=(YES,OFF)] [,MODE=SYSTEM] </pre>

¹ Of course, a LOCAP file is not the only way your program can receive messages; you can specify that input messages are to be queued to input queues (INPUT=YES), or to a process file, e.g., INPUT=PRF1, and your program would issue GETTCPs against these queues.

Table 2-16. Applicability of LOCAP Macroinstruction and its Operands

Macro: LOCAP	ICAM Network Type and Kind of Program Supported										
	Direct Data Interface		Dedicated Networks			Global Networks					
Operand Name	DDI	RBP	TCI (IMS)	STDMCP	CMCS (COBOL)	STDMCP	TCI (IMS)	COBOL	DMI	DCA	Public Data Networks
	NTR										
	RPG										
	IDES										
*LOCAP	-	-	-	-	-	R	R	R	R	R	R
label	-	-	-	-	-	R	R	R	R	R	R
DUSTERR=	-	-	-	-	-	O	-	-	-	-	-
HIGH=	-	-	-	-	-	O	O	-	-	O	O
IAS=	-	-	-	-	-	-	-	-	R	R	O
JOBINIT=	-	-	-	-	-	-	-	O	-	-	-
JOBNAME=	-	-	-	-	-	-	-	O	-	-	-
LOW=	-	-	-	-	-	O	O	-	-	O	O
MEDIUM=	-	-	-	-	-	O	O	-	-	O	O
MODE=	-	-	-	-	-	-	-	-	O	O	O
PROTYP=	-	-	-	-	-	-	-	-	-	O	O
REMOTE=	-	-	-	-	-	-	-	-	-	O	O
TYPE=	-	-	-	-	-	R	R	R	R	R	R

*Shows macro applicability

LEGEND:

R = Required O = Optional - = Not applicable

Label

LOCAP-name

Identifies a LOCAP file. It is the name your program must specify in the APPS operand of an NATTACH interface macro when it requests attachment to this global network. Other communications user programs direct messages to this LOCAP file by means of this label. If you are running Telcon, this name must be paired with the Telcon configuration XEU statement or the DESTSSU parameter of the XEU statement.

Operands

TYPE=(STDCP)

Specifies the standard interface is used to communicate with this LOCAP file.

TYPE=(DMI)

Specifies the demand mode interface is used to communicate with this LOCAP file. Required if ICAM supports interactive services to allow terminals to be used as workstations or remote workstations, or for distributed data processing users.

TYPE=(TCI)

Specifies the transaction control interface for the information management system (IMS).

DUSTERR=INLINE

Specifies that, if an error occurs during DUST macro processing, all returns are inline. If you don't specify DUSTERR=INLINE and an error occurs during DUST macro processing, ICAM returns control at the NETREQ ERRET= address you specify.

Note: The DUSTERR=INLINE specification is correct only when your program is coded to match the operand you specify.

LOW, MEDIUM, HIGH

Generates up to three input queues for messages destined for this LOCAP file. It is necessary to have at least one of these queues if you are going to use direct communications between your programs in a local or multicomputer global network or if any terminals specify this LOCAP file in the INPUT operand of the TERM macro.

LOW=MAIN

Creates a main storage input queue with low priority.

LOW=filename

Specifies a 1- to 7-character name of a disk file for low priority messages you created by means of a DISCFILE macro.

MEDIUM=MAIN

Creates a main storage input queue with medium priority.

MEDIUM=filename

Specifies a 1- to 7-character name of a disk file for medium priority messages you created by means of a DISCFILE macro.

HIGH=MAIN

Creates a main storage queue with high priority.

HIGH=filename

Specifies a 1- to 7-character name of a disk file for high priority messages you created by means of a DISCFILE macro.

REMOTE=(node)

In a multinode network, specifies the 1- to 4-character name of the destination node in which the remote program resides. This name must be the same that is specified for the REMOTE keyword of the LPORT macro. This LOCAP statement must follow the VLINE and LPORT statements with which these LOCAPs are associated.

REMOTE=(subname, PDN)

Defines a LOCAP file in a packet-switched public data network (PDN) environment that physically exists in a remote node.

subname

Specifies the symbolic name of the SUB macro in a packet-switched PDN that defines the remote subscriber.

PDN

Specifies a packet-switched public data network.

JOBNAME=jobname

Is the 1- to 8-character name specified in the job control JOB statement that identifies the jobstream that executes your COBOL program. If you omit this operand, the label of this LOCAP macro is used.

JOBINIT=

Controls the scheduling of a COBOL communications program when initial input is received, and the reporting of same by means of a datagram.

JOBINIT=LOAD

Indicates that your COBOL program is automatically loaded and executed when the initial message is received.

JOBINIT=REPORT

Indicates that your COBOL program receives a report of the initial message.

LOCAP

For details on how to use the **JOBINIT** operand, see the **ICAM COBOL** message control system (CMCS) utility in the *ICAM Utilities Programming Guide* (UP-9748). Also see the **PRIMARY** operand in the **SESSION** macro.

IAS=(YES,OFF)

Specifies that interactive services is required (**YES**) and that **DICE** is not required (**OFF**). This operand is required when **TYPE=(DMI)** is specified.

MODE=SYSTEM

Specifies that a remote workstation in system mode is to use this **LOCAP** file for entry to interactive services. Only one **LOCAP** file of this type is permitted in a network containing remote workstations, and **TYPE=(DMI)** must be specified.

2.16. How to Create Remote Session Entry Tables (LPORT)

This macro defines and creates a remote session entry table for each DCA logical port. ICAM uses the information in this table to record and control activity on the port.

For UDLC/NRM networks, the LPORT macro must follow the corresponding STATION macro.

Table 2-17 describes the interface and type of network definition in which you may use this macro. It also details the applicability of each operand in the macro. The first line in the table is the name of the macro itself preceded by an asterisk (to distinguish it from its operands).

Format:

LABEL	ΔOPERATIONA	OPERAND
	LPORT	LINE=name, REMOTE=name, PORT=nnnn, EU1=name, EU2=name, USERTP= { DMI TCI STDMP } ,CATP= C [,PRI= { 1 2 3 # }]

Operands

LINE=name

Is the 1- to 4-character label from the DCPCHNL or VLINE macro. The name must begin with an alphabetic character.

REMOTE=name

Is the 1- to 4-character name of the destination node. This name is a logical identifier of the remote node and must match the remote name used in remote LOCAP and TERM macros.

Table 2-17. Applicability of LPORT Macroinstruction and Its Operands

Macro: LPORT	ICAM Network Type and Kind of Program Supported											
	Operand Name	Direct Data Interface		Dedicated Networks				Global Networks				
DDI		RBP	TCI (IMS)	STDMCP	CMCS (COBOL)	STDMCP	TCI (IMS)	COBOL	DMI	DCA	Public Data Networks	
NTR	RPG										CS	PS
	IDES											
*LPORT	-	-	-	-	-	-	-	-	-	O	R	-
CATP=	-	-	-	-	-	-	-	-	-	O	O	-
EU1=	-	-	-	-	-	-	-	-	-	R	R	-
EU2=	-	-	-	-	-	-	-	-	-	R	R	-
LINE=	-	-	-	-	-	-	-	-	-	R	R	-
PORT=	-	-	-	-	-	-	-	-	-	R	R	-
PRI=	-	-	-	-	-	-	-	-	-	O	O	-
REMOTE=	-	-	-	-	-	-	-	-	-	R	R	-
USERTP=	-	-	-	-	-	-	-	-	-	R	R	-

*Shows macro applicability

LEGEND:

- R = Required
- O = Optional
- = Not applicable
- PS = Packet-switched
- CS = Circuit-switched

PORT=nnnn

Is the 4-digit port number in the range of 1 to 4096.

EU1=name

Is the label of the TERM, PRCS, or LOCAP macro defining the local end user.

EU2=name

Is the label of the **LOCAP**, **PRCS**, or **TERM** macro defining the remote end user in another computer. This name must not be supplied for a program to Telcon terminal session.

USERTP= { **DMI**
 TCI
 STDMCP }

Indicates that the session operates through the demand mode interface (**DMI**), transaction control interface (**TCI**), or standard interface for DCA global networks (**STDMCP**). Specify **STDMCP** for circuit-switched public data networks.

CATP=

Defines the class of recovery procedure implemented by DCA DTP protocol.

CATP=C

Indicates use of dynamic sessions with provision for error recovery and assurance units for **STDMCP** and **TCI** users when output delivery notification is requested.

PRI=n

Indicates priority from 1 to 4. The default is 4. The highest priority is 1.

2.17. How to Define a Public Data Network (PDN)

This macro specifies the name and attributes of the public data network to which you have subscribed. This macro must not be specified for DATEX-L public data network. (For DATEX-L, see 3.6.3.) The PDN macro must appear once in an ICAM global network definition after you have declared all of the macros for local communications.

Table 2-18 describes the interface and type of network definition in which you may use this macro. It also details the applicability of each operand in the macro. The first line in the table is the name of the macro itself preceded by an asterisk (to distinguish it from its operands).

Format

LABEL	ΔOPERATIONΔ	OPERAND
symbol	PDN	CARRIER= { DATAPAC DATEX DDX IBERPAC NORDIC PSS TRANSPAC } [,TYPE= { CIRCUIT PACKET }] [,L3MOD= { 128 8 }] [,PKTSIZ=size] [,MXCALL= { n 2 }]

Label

symbol

Is a required 1- to 4-character label used to reference this macro.

Operands

CARRIER=

Specifies the name of the public data network common carrier you are using. All networks are packet-switched except NORDIC.

CARRIER=DATAPAC

Specifies the Canadian DATAPAC public data network.

CARRIER=DATEX

Specifies the German DATEX-P public data network.

Table 2-18. Applicability of PDN Macroinstructions and Its Operands

Macro: PDN	ICAM Network Type and Kind of Program Supported											
	Direct Data Interface		Dedicated Networks			Global Networks						
Operand Name	DDI	RBP	TCI (IMS)	STDMCP	CMCS (COBOL)	STDMCP	TCI (IMS)	COBOL	DMI	DCA	Public Data Networks	
	NTR										RPG	IDES
*PDN	-	-	-	-	-	-	-	-	-	-	R	R
label	-	-	-	-	-	-	-	-	-	-	R	R
CARRIER=	-	-	-	-	-	-	-	-	-	-	R	R
DATAPAC	-	-	-	-	-	-	-	-	-	-	-	O
DATEX	-	-	-	-	-	-	-	-	-	-	-	O
DDX	-	-	-	-	-	-	-	-	-	-	-	O
IBERPAC	-	-	-	-	-	-	-	-	-	-	-	O
NORDIC	-	-	-	-	-	-	-	-	-	-	O	-
PSS	-	-	-	-	-	-	-	-	-	-	-	O
TRANSPAC	-	-	-	-	-	-	-	-	-	-	-	O
L3MODE=	-	-	-	-	-	-	-	-	-	-	-	O
MXCALL=	-	-	-	-	-	-	-	-	-	-	-	O
PKTSIZ=	-	-	-	-	-	-	-	-	-	-	-	O
TYPE=	-	-	-	-	-	-	-	-	-	-	R	O

*Shows macro applicability

† Not applicable to the DATEX-L public data network.

LEGEND:

R = Required

CS = Circuit-switched

O = Optional

PS = Packet-switched

- = Not applicable

CARRIER=DDX
Specifies the Japanese DDX public data network.

CARRIER=IBERPAC
Specifies the Spanish public data network.

CARRIER=NORDIC
Specifies the Danish, Finnish, Norwegian, and Swedish NORDIC circuit-switched public data network.

CARRIER=PSS
Specifies the United Kingdom's PSS public data network.

CARRIER=TRANSPAC
Specifies the French TRANSPAC public data network.

TYPE=
Specifies the type of service supplied by the PDN in the CARRIER operand.

TYPE=CIRCUIT
Specifies a circuit-switched public data network.

TYPE=PACKET
Specifies a packet-switched public data network.

L3MOD= { 128 }
 { 8 }

This operand applies only to packet-switching public data networks and specifies the modulus of the level 3 send and receive window. That is, it is the number of packets that may be sent or received in one level 3 window.

PKTSIZ=size

This operand applies only to packet-switched networks and specifies the maximum size in bytes of the data portion of a data packet. Specify a value according to the following list:

DATAPAC, DATEX, IBERPAC, 128 or 256 (default is 128)
PSS, TRANSPAC

DDX 256 (default is 256)

Note: For IBERPAC and PSS, the size used for input and output negotiation is the size specified by the PKTSIZ keyword.

MXCALL= { n }
 { 2 }

This operand applies to the packet-switched networks only and specifies the number of times ICAM will attempt to reestablish a connection over a switched virtual circuit to a remote subscriber. You may specify any value between 0 and 15.

2.18. How to Specify Polling Groups and Polling Intervals for Remote Workstations (PGROUP)

This macro defines a polling group for remote workstations (RWS) and the UTS 20X terminal (see 3.6.1 and Table 3-8). It specifies the time interval that a polling group is polled normally and the time interval it is polled when the group is down.

It must immediately precede TERM macros that form a polling group of remote workstations or UTS 20X terminals.

Table 2-19 describes the interface and type of network definition in which you may use this macro. It also details the applicability of each operand in the macro. The first line in the table is the name of the macro itself preceded by an asterisk (to distinguish it from its operands).

Format

LABEL	OPERATION	OPERAND
not used	PGROUP	PGID=xx [,PTIME= ((m) , (n))]

Table 2-19. Applicability of PGROUP Macroinstruction and Its Operands

Macro: PGROUP	ICAM Network Type and Kind of Program Supported										
	Direct Data Interface		Dedicated Networks			Global Networks					
Operand Name	DDI	RBP	TCI (IMS)	STDMCP	CMCS (COBOL)	STDMCP	TCI (IMS)	COBOL	DMI	DCA	Public Data Networks
*PGROUP	-	-	-	-	-	O	O	O	O	O	O
PGID=	-	-	-	-	-	R	R	R	R	R	R
PTIME=	-	-	-	-	-	O	O	O	O	O	O

*Shows macro applicability

LEGEND:

R = Required O = Optional - = Not applicable

Operands

PGID=xx

Specifies the 2-digit hexadecimal value of the polling group remote identifier (rid).

PTIME= ({m} , {n})

Specifies the normal and slow polling intervals for this polling group.

m

Specifies the normal polling interval for this polling group in seconds. Specify a value from 1 to 255.

n

Specifies the slow polling interval for this polling group in seconds when the polling group is down. Specify a value from 1 to 255.

Example

1		72
<hr/>		
LN01	LINE DEVICE=(RWS),TYPE=(9600,SWCH,SYNC),ID=8, RETRY=(6,4) PGROUP PGID=28	X
TM01	TERM FEATURES=(U20,1920),ADDR=(28,51),HIGH=MAIN,MEDIUM=MAIN, LOW=MAIN,AUX1=(COP,73),AUX2=(TP,74)	X
TM02	TERM FEATURES=(U20,1920),ADDR=(28,52),HIGH=MAIN,MEDIUM=MAIN, LOW=MAIN,AUX1=(COP,73),AUX2=(TP,74) PGROUP PGID=29,PTIME=(2,60) (NEW POLL GROUP)	X
TM03	TERM FEATURES=(U20),ADDR=(29,51),HIGH=MAIN,MEDIUM=MAIN, LOW=MAIN,AUX1=(COP,73),AUX2=(TP,74)	X
TM04	TERM FEATURES=(U20,9600),ADDR=(29,52),HIGH=MAIN,MEDIUM=MAIN, LOW=MAIN,AUX1=(COP,73),AUX2=(TP,74)	X

2.19. How to Create a Process File (PRCS)

The PRCS macro creates a process file for temporarily storing messages. Messages are stored in a process file in any of four ways:

1. ICAM places messages coming from terminals in a process file if you identify a process file on the INPUT operand of the LINE or TERM macro.
2. Your MPPS routine can place messages in a process file; you identify the MPPS routine on the INPUT operand of the LINE or TERM macro.
3. Your program can place messages in a process file with PUTCP macros.
4. Messages can be placed on a process file by means of a QTRANS macro.

Programs access the messages in a process file by issuing GETCP macros.

A process file consists of one, two, or three queues in main storage or on disk, for low, medium, and high priority messages. If your program requests these messages without a priority level, the messages are accessed in order of priority - first the high priority messages, followed by the medium, and then the low. If your program does specify a priority level, the queues are accessed as shown in Table 2-20.

Process files are used in standard interface and transaction control interface (IMS) networks. COBOL programs using the COBOL message control system require at least one process file for each program. Since the COBOL message control system needs only one queue for each process file, you should not specify a high or medium priority queue when defining a process file for it. You use the LOW operand to specify whether the single queue should be on disk or in main storage.

Table 2-20 describes the interface and type of network definition in which you may use this macro. It also details the applicability of each operand in the macro. The first line in the table is the name of the macro itself preceded by an asterisk (to distinguish it from its operands).

Format

LABEL	ΔOPERATIONΔ	OPERAND
prcs-name	PRCS	<pre>[,LOW= {filename } {MAIN }] [,MEDIUM= {filename } {MAIN }] [,HIGH= {filename } {MAIN }] [,REMOTE= ({node-id } {subname,PDN })]</pre>

Table 2-20. Applicability of PRCS Macroinstruction and Its Operands

Macro: PRCS	ICAM Network Type and Kind of Program Supporte										
Operand Name	Direct Data Interface		Dedicated Networks			Global Networks					
	DDI	RBP									
	NTR		TCI (IMS)	STDMCP	CMCS (COBOL)	STDMCP	TCI (IMS)	COBOL	DMI	DCA	Public Data Networks
	RPG										
IDES											
*PRCS	-	-	O	O	R	O	O	R	-	O	O
label	-	-	R	R	R	R	R	R	-	R	R
HIGH=	-	-	O	O	O	O	O	O	-	O	O
LOW=	-	-	O	O	O	O	O	O	-	O	O
MEDIUM=	-	-	O	O	O	O	O	O	-	O	O
REMOTE=	-	-	-	-	-	-	-	-	-	O	O

*Shows macro applicability

LEGEND:

R = Required O = Optional - = Not applicable

Label

prcs-name

A 1- to 4-character label that identifies this process file.

Operands

LOW=filename

Creates a low priority queue for this process file on a disk file you name in a DISCFILE macro.

LOW=MAIN

Creates a low priority queue for this process file in main storage.

MEDIUM=filename

Creates a medium priority queue for this process file on a disk file you name in a DISCFILE macro.

MEDIUM=MAIN

Creates a medium priority queue for this process file in main storage.

HIGH=filename

Creates a high priority queue for this process file on a disk file you name in a DISCFILE macro.

HIGH=MAIN

Creates a high priority queue for this process file in main storage.

Note: If you omit the LOW, MEDIUM, and HIGH operands, a low priority queue is created for this process file in main storage. See Table 2-21 for the relationship between your queue specifications and the way your program accesses messages from the process file.

Table 2-21. How Process File Queues Are Accessed

PRCS Queues Specified			Queues Accessed by GETCP/PUTCP or MREAD/MWRITE			
Low (L)	Medium (M)	High (H)	No Priority Level	Priority Level		
				Low	Medium	High
No	No	No	L	L	L	L
No	No	Yes	H	H	H	H
No	Yes	No	M	M	M	M
No	Yes	Yes	H, M	M	M	H
Yes	No	No	L	L	L	L
Yes	No	Yes	H, L	L	L	H
Yes	Yes	No	M, L	L	M	M
Yes	Yes	Yes	H, M, L	L	M	H

REMOTE=(node-id)

This operand is used only in a multinode non-DCA global network. Specifies a 1- to 4-character name of the remote node where this process file is located. The node-id must match the label on the NODE macro that refers to the remote computer node. It allows your program to:

- access messages coming from terminals attached to another system
- access messages from programs using another system
- send messages to programs using another system

PRCS

REMOTE=(subname,PDN)

For packet-switched public data networks (PDN) only, specifies this process file is located in a remote data terminal equipment and associates it with the proper subscriber to a trunk. Each remote process file must be described following the subscriber (SUB macro) to which it belongs.

subname

Specifies the symbolic name of the SUB macro in a packet-switched PDN that defines the remote system containing the process file.

PDN

Specifies this is a public data network user.

Example

1

72

PRF1	PRCS	LOW=MAIN
PRF2	PRCS	LOW=FILQU1,HIGH=MAIN
PRF3	PRCS	LOW=MAIN
PRFA	PRCS	LOW=DISFL1,MEDIUM=DISFL1,HIGH=DISFL1
PRFG	PRCS	LOW=MAIN,REMOTE=(COM1)
PRFH	PRCS	LOW=MAIN,REMOTE=(SUB1,PDN)

2.20. How to Define a Permanent Virtual Circuit on a Packet-Switched Public Data Network (PVC)

This macro declares the attributes of a permanent virtual circuit connecting a local and a remote subscriber; that is, the most recently declared local subscriber declared by a TRUNK macro, and the most recently declared remote subscriber declared by a SUB macro.

Permanent virtual circuits are effectively point-to-point, nonswitched circuits over which only data, reset, interrupt, and flow control packets can flow.

Table 2-22 describes the interface and type of network definition in which you may use this macro. It also details the applicability of each operand in the macro. The first line in the table is the name of the macro itself preceded by an asterisk (to distinguish it from its operands).

Format

LABEL	OPERATION	OPERAND
symbol	PVC	LCN=number [, LCGN= { number }] [, IWS=number] [, OWS=number]

Label

symbol

Is a required 1- to 4-character label that identifies this permanent virtual circuit.

Operands

LCN=number

Specifies the logical channel number of this permanent virtual circuit. Specify as follows:

DATAPAC	1-4095
DATEX	1-4095
DDX	1-255
IBERPAC	1-4095
PSS	1-255
TRANSPAC	0-4095

One line can specify up to 4096 permanent virtual circuits.

Table 2-22. Applicability of PVC Macroinstruction and its Operands

Macro: PVC	ICAM Network Type and Kind of Program Supported										
Operand Name	Direct Data Interface		Dedicated Networks				Global Networks				
	DDI	RBP	TCI (IMS)	STDMCP	CMCS (COBOL)	STDMCP	TCI (IMS)	COBOL	DMI	DCA	†Public Data Networks
*PVC	-	-	-	-	-	-	-	-	-	-	O
label	-	-	-	-	-	-	-	-	-	-	R
LCN=	-	-	-	-	-	-	-	-	-	-	R
LCGN=	-	-	-	-	-	-	-	-	-	-	O
IWS=	-	-	-	-	-	-	-	-	-	-	O
OWS=	-	-	-	-	-	-	-	-	-	-	O

*Shows macro applicability

†Packet-switched only

LEGEND:

R = Required O = Optional - = Not applicable

LCGN= { number }

Specifies the logical channel group number of this permanent virtual circuit. It is valid for DDX and PSS public data networks only. Valid values for DDX are 0-15, and the default is 0. Valid values for PSS are 0-7, and the default is also 0.

IWS=number

Specifies the input window size for this permanent virtual circuit. Window size is the maximum number of unacknowledged packets allowed in a transmission. It is used only for DDX, IBERPAC, and PSS public data networks. Valid values for DDX are 1-15, and the default is 15. Valid values for PSS are 1-7, and the default is 7. Valid values for IBERPAC are 2-7, and the default is 2.

OWS=number

Specifies the output window size for this permanent virtual circuit. Window size is the maximum number of unacknowledged packets allowed in a transmission. It is used only for DDX, IBERPAC, and PSS public data networks. Valid values for DDX are 1-15, and the default is 15. Valid values for PSS are 1-7, and the default is 7. Valid values for IBERPAC are 2-7, and the default is 2.

2.21. How to Define Remote Data Terminal Equipment in a Circuit-Switched Public Data Network (RDTE)

This macro defines the attributes of a remote data terminal equipment (RDTE) in a circuit-switched public data network.

Table 2-23 describes the interface and type of network definition in which you may use this macro. It also details the applicability of each operand in the macro. The first line in the table is the name of the macro itself preceded by an asterisk (to distinguish it from its operands).

Format

LABEL	ΔOPERATIONA	OPERAND
symbol	RDTE	[ADDRESS=rdte-address] [,ABBADDR=abbr-address] [,DIRECT= { NO } { YES }] [,CUGADDR=user-grp-id] [,TIMER= { n } { 0 }] [,DSCO= { n } { 5 }] [,DSCI= { n } { 5 }

Label

symbol

Specifies the 1- to 4-character label of this macro.

Operands

ADDRESS=rdte-address

Specifies the normal full address of the remote data terminal equipment. This operand is required when the address-call facility is used or when INID or OUTID is specified by the LDTE macro.

ABBADDR=abbr-address

Specifies the 2-character abbreviated address of the remote data terminal equipment. This operand must not be specified if the DIRECT=YES or CUGADDR operand is specified.

Table 2-23. Applicability of RDTE Macroinstruction and Its Operands

Macro: RDTE	ICAM Network Type and Kind of Program Supported										
	Direct Data Interface		Dedicated Networks			Global Networks					
Operand Name	DDI	RBP	TCI (IMS)	STDMCP	CMCS (COBOL)	STDMCP	TCI (IMS)	COBOL	DMI	DCA	†Public Data Networks
	NTR										
	RPG										
	IDES										
• RDTE	-	-	-	-	-	-	-	-	-	-	R
label	-	-	-	-	-	-	-	-	-	-	R
ADDRESS=	-	-	-	-	-	-	-	-	-	-	O
ABBADDR=	-	-	-	-	-	-	-	-	-	-	O
DIRECT=	-	-	-	-	-	-	-	-	-	-	O
CUGADDR=	-	-	-	-	-	-	-	-	-	-	O
TIMER=	-	-	-	-	-	-	-	-	-	-	O
DSCO=	-	-	-	-	-	-	-	-	-	-	O
DSCI=	-	-	-	-	-	-	-	-	-	-	O

*Shows macro applicability

†Circuit-switched only

LEGEND:

R = Required O = Optional - = Not applicable

DIRECT= { NO }
 { YES }

Specifies that this remote data terminal equipment is using the direct-call facility. This operand must not be specified if the ABBADDR or CUGADDR operand is specified.

CUGADDR=user-grp-id

Specifies the closed-user-group number to use when calling this remote data terminal equipment. This operand must not be specified if the DIRECT=YES or ABBADDR operand is specified.

TIMER= { n }
 { 0 }

Specifies the time in seconds the connection of this remote data terminal equipment is held when there is no activity. The range is 0-32767. This operand is applicable only when connection is to another computer. If 0 is specified, the connection will not be disconnected by this condition.

DSCO= { n }
 { 0 }

Specifies the time in seconds the connection of this remote data terminating equipment is held when there is no activity after output. The range is 0-32767. This operand is applicable only when connection is to a UTS 20X terminal. If 0 is specified, the connection will not be disconnected by this condition.

DSCI= { n }
 { 0 }

Specifies the time in seconds the connection of this remote data terminating equipment is held when there is no activity after input. The range is 0-32767. This operand is applicable only when connection is to a UTS 20X terminal. If 0 is specified, the connection will not be disconnected by this condition.

2.22. How to Establish Static Sessions in a Global Network (SESSION)

This macro defines a static session between two global non-DCA network end users. It is also used to declare a static session over a packet-switched public data network permanent virtual circuit (PVC). For sessions between two local end users, only the end user operands EU1 and EU2 are required.

Notes:

1. *If a session is to be established dynamically, do not specify SESSION. For example, if you are using interactive services (LOCAP macro specified as TYPE=(DMI)) or a terminal generated as a remote workstation (DEVICE=(RWS)), you cannot specify SESSION to define a session path between these end users. Static sessions cannot be used in a Telcon environment.*
2. *Do not specify the SESSION macro for any terminal that may use the terminal spooling capability. This includes any UNISCOPE or DCP terminal generated with PRIMARY or SECONDARY specified. Terminal spooling requires dynamic DMI sessions on both screens.*

Table 2-24 describes the interface and type of network definition in which you may use this macro. It also details the applicability of each operand in the macro. The first line in the table is the name of the macro itself preceded by an asterisk (to distinguish it from its operands).

Format

LABEL	OPERATION	OPERAND
	SESSION	[PRIMARY,] EU1=(name), EU2=(name) [, PVC=name]

Operands

PRIMARY

Indicates that this session is between an end user (such as a terminal) and a LOCAP file, which is the exclusive recipient of that end user's input. A primary session is used when a communications user program is loaded and executed due to an initial input message received. If your program is not to be scheduled due to an initial input message, you must omit this operand. Note that this operand is positional and must be the first operand if specified.

Note: *For multiple sessions to the same process file, only one session may specify the PRIMARY command.*

Table 2-24. Applicability of SESSION Macroinstruction and Its Operands

Macro: SESSION	ICAM Network Type and Kind of Program Supported										
Operand Name	Direct Data Interface		Dedicated Networks			Global Networks					
	DDI	RBP									
	NTR		TCI (IMS)	STDMCP	CMCS (COBOL)	STDMCP	TCI (IMS)	COBOL	DMI	DCA	†Public Data Networks
	RPG		IDES								
*SESSION	-	-	-	-	-	O	O	R	-	-	O
EU1 =	-	-	-	-	-	R	R	R	-	-	R
EU2 =	-	-	-	-	-	R	R	R	-	-	R
PVC =	-	-	-	-	-	-	-	-	-	-	R

*Shows macro applicability

†Packet-switched only

LEGEND:

R = Required O = Optional - = Not applicable

For example, as shown in Figure 2-2, if you define LOCAP file 'A' as the recipient of terminal T1's input in the INPUT operand of the TERM macro for T1, and you specified the PRIMARY operand in a SESSION macro, only LOCAP file 'A' could receive input from T1. Therefore, only the program linked to LOCAP file 'A' can access input messages from terminal T1. Terminal T1 can, however, receive output messages from CUPs 1, 2, and 3.

EU1=(name)

Is a 1- to 4-character name of a local end user as defined in the label field of a LOCAP, TERM, or PRCS macro in this network definition.

EU2=(name)

Is a 1- to 4-character name of a local or remote end user as defined in the label field of a LOCAP, TERM, or PRCS macro.

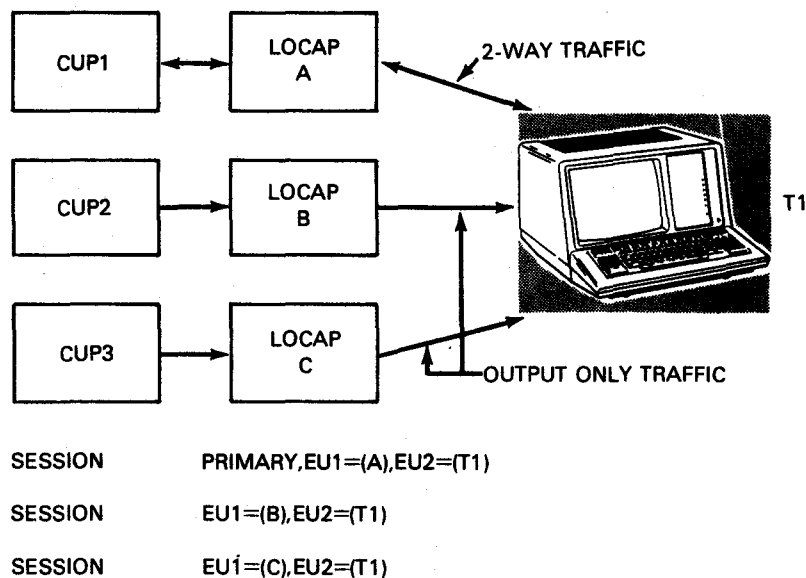

Figure 2-2. Specifying a Primary Session

PVC=name

Is the symbolic name of the permanent virtual circuit in a packet-switched public data network over which this static session is conducted. Specify the label of the PVC macro that defines the permanent virtual circuit used.

You may only define one static session over each permanent virtual circuit. All SESSION macros associated with a given trunk must be grouped following the end user declarations for that trunk.

Example

In the following example, A1 is the symbolic name of the local end user, A2 is the symbolic name of the remote end user, and V0 is the symbolic name of the permanent virtual circuit used to establish a static session.

```
SESSION EU1=A1,EU2=A2,PVC=V0
```

Note: You cannot establish static sessions over switched virtual circuits.

2.23. How to Define a Station Profile Table (STATION)

This macro creates a station profile table for each station (local and remote) connected to the specified VLINE. It specifies the unique characteristics of a particular station and the flow control parameters required by the link level control module. Use this macro only when DEVICE=NRM is specified on the VLINE macro.

Table 2-25 describes the interface and type of network definition in which you may use this macro. It also details the applicability of each operand in the macro. The first line in the table is the name of the macro itself preceded by an asterisk (to distinguish it from its operands).

Format

LABEL	OPERATION	OPERAND
symbol	STATION	TYPE= (TWA, { PRIMARY } { SECONDARY }) [, REMOTE=node-name] [, LINE=vline-name] [, ADDRESS=nn] [, WINDOW= { value } { 7 }] [, MAXIFLD= { nnnn } { 268 }] [, CALL=phone-number]

Label

symbol

Is a required 1- to 4-character name that is specified as the REMOTE= keyword parameter on the LPORT, TERM, and LOCAP macros associated with this station.

Operands

TYPE= (TWA, { PRIMARY }
 { SECONDARY })

Specifies characteristics of this station.

TWA

Indicates that this logical station operates in a two-way-alternate (TWA) mode. In this mode, the station cannot send and receive simultaneously.

Table 2-25. Applicability of STATION Macroinstruction and Its Operands

Macro: STATION	ICAM Network Type and Kind of Program Supported										
	Direct Data Interface		Dedicated Networks			Global Networks					
Operand Name	DDI	RBP	TCI (IMS)	STDMCP	CMCS (COBOL)	STDMCP	TCI (IMS)	COBOL	DMI	DCA	Public Data Networks
	NTR										
	RPG										
	IDES										
*STATION	-	-	-	-	-	-	-	-	-	R	-
symbol	-	-	-	-	-	-	-	-	-	R	-
TYPE	-	-	-	-	-	-	-	-	-	R	-
REMOTE	-	-	-	-	-	-	-	-	-	O	-
LINE	-	-	-	-	-	-	-	-	-	O	-
ADDRESS	-	-	-	-	-	-	-	-	-	O	-
WINDOW	-	-	-	-	-	-	-	-	-	O	-
MAXIFLD	-	-	-	-	-	-	-	-	-	O	-
CALL	-	-	-	-	-	-	-	-	-	O	-

*Shows macro applicability

LEGEND:

R = Required O = Optional - = Not applicable

PRIMARY

Indicates that the station is configured for primary link control.

SECONDARY

Indicates that the station is configured for secondary link control.

Note: When two UDLC/NRM stations are connected over a link (VLINE), one station must be defined as primary and the other as secondary. For UNIX O/S file transfers, the OS/3 system is the primary station and the UNIX O/S is the secondary station.

STATION

REMOTE=node-name

Indicates that this station is defined on a remote node. If this parameter is not specified, the station is considered a local entity.

LINE=vl ine-name

Specifies the name of the VLINE. Use this operand only for local stations.

ADDRESS=nn

Specifies a two-digit, hexadecimal (01 to FE) address of the secondary station on a local or remote node.

WINDOW= { value }
7

Specifies the number of frames (1 to 7) that can be sent from this station before an acknowledgement is required.

MAXIFLD= { nnnn }
255

Specifies the maximum I field size of a frame received from a remote station. Calculate the maximum I field size by subtracting the size of the UDLC header from the maximum size of the DCA header (13 bytes) and adding that difference to the maximum user data size of a frame.

Note: The link buffer size specified on the LINKPAK parameter of the BUFFERS macro must be large enough to support this maximum frame size.

CALL=phone-number

A numeric or alphanumeric telephone number used to dial out from the OS/3 system.

2.24. How to Define a Remote Subscriber on a Packet-Switched Public Data Network (SUB)

This macro declares the attributes of a remote subscriber data terminal equipment (DTE) in a packet-switched public data network.

One or more SUB macros must appear following each TRUNK macroinstruction. You establish logical connections between local and remote data terminal equipments by relating TRUNK and SUB statements; i.e., all remote subscribers declared in SUB macros following a TRUNK macro can communicate with the local data terminal equipment using that trunk.

Table 2-26 describes the interface and type of network definition in which you may use this macro. It also details the applicability of each operand in the macro. The first line in the table is the name of the macro itself preceded by an asterisk (to distinguish it from its operands).

Format

LABEL	ΔOPERATIONΔ	OPERAND
symbol	SUB	CALLNO=dte-address [,CUG= { closed-user-group-code }] [,REVCHG= { N[O] } { Y[ES] } { ACP } { REQ } }] [,MUX= { Y[ES] } { N[O] }] [,CATP= { F } { G } { H }] [,IWS=input-window-size] [,OWS=output-window-size] [,NEGO= { N[O] } { Y[ES] }] [,CALLING= { N[O] } { Y[ES] }]

Label

symbol

Is a required 1- to 4-character label used to reference this macro.

Table 2-26. Applicability of SUB Macroinstruction and Its Operands

Macro: SUB	ICAM Network Type and Kind of Program Supported											
Operand Name	Direct Data Interface		Dedicated Networks			Global Networks					†Public Data Networks	
	DDI	RBP	TCI (IMS)	STDMCP	CMCS (COBOL)	STDMCP	TCI (IMS)	COBOL	DMI	DCA		
*SUB	-	-	-	-	-	-	-	-	-	-	-	O
label	-	-	-	-	-	-	-	-	-	-	-	R
CALLING	-	-	-	-	-	-	-	-	-	-	-	O
CALLNO	-	-	-	-	-	-	-	-	-	-	-	R
CUG	-	-	-	-	-	-	-	-	-	-	-	O
REVCHG=	-	-	-	-	-	-	-	-	-	-	-	O
MUX=	-	-	-	-	-	-	-	-	-	-	-	O
CATP=	-	-	-	-	-	-	-	-	-	-	-	O
IWS=	-	-	-	-	-	-	-	-	-	-	-	O
OWS=	-	-	-	-	-	-	-	-	-	-	-	O
NEGO	-	-	-	-	-	-	-	-	-	-	-	O

*Shows macro applicability

†Packet-switched only

LEGEND:

R = Required O = Optional - = Not applicable

Operands

CALLNO=dte-address

Specifies the level 3 DTE address of the remote subscriber. You obtain this information from the public data network at subscription time.

CUG= {closed-user-group-code}

Specifies the closed user group code for this subscriber. This optional facility permits a group of users to communicate with each other, but prevents communications with others not in the group. If you do not specify this operand, the value zero (0) is used; this is the value assigned to all users that do not belong to a closed user group. Valid values for this operand are 0 - 99.

REVCHG=N[O]

Specifies that collect calls will not be accepted.

REVCHG=Y[ES]

Specifies that the local subscriber will accept collect calls from the remote subscriber.

REVCHG=ACP

Specifies that the local subscriber will only accept (not request) collect calls from the remote subscribers.

REVCHG=REQ

Specifies that the local subscriber will only request (not accept) collect calls to the remote subscriber.

MUX=Y[ES]

Specifies that all dynamic sessions with this subscriber are multiplexed over a single virtual circuit.

MUX=N[O]

Specifies that messages are not multiplexed.

CATP=

Specifies the category of procedure used by this remote subscriber for system session control and port flow control.

CATP=F

Specifies an OS/3 to V^C/9 public data network connection.

CATP=G

Specifies host-to-host or host-to-UTS 4000 dynamic sessions over switched or permanent virtual circuits. This protocol is the primary category of procedure and is supported for all networks.

CATP=H

For DDX networks only, specifies host to foreign node over permanent virtual circuits using static sessions. You must specify category H and noncategory H subscribers on the same trunk.

IWS=input-window-size

Specifies the level 3 input window size used for all switched virtual circuit connections between the local data terminal equipment and this remote subscriber. This operand is valid for DDX, IBERPAC, and PSS public data networks only; other networks use the WS parameter in the TRUNK macro. Valid values for DDX are 1-15, and the default is 15. Valid values for IBERPAC are 2-7, and the default is 2. Valid values for PSS are 1-7 and the default is 2.

OWS=output-window-size

Specifies the level 3 output window size used for all switched virtual circuit connections between the local data terminal equipment and this remote subscriber. This operand is valid for DDX, IBERPAC, and PSS public data networks only; other networks use the WS parameter in the TRUNK macro. Valid values for DDX are 1-15 and the default is 15. Valid values for IBERPAC are 2-7, and the default is 2. Valid values for PSS are 1-7 and the default is 2.

NEGO= { N[O] }
 { Y[ES] }

Specifies the level 3 negotiator option. This operand is valid for IBERPAC and PSS public data networks only.

CALLING= { N[O] }
 { Y[ES] }

Specifies whether the local DTE address is included in the call request packet for switched virtual circuits (SVCs). This operand applies only to the IBERPAC public data networks.

2.25. How to Specify Terminal Characteristics (TERM)

This macro specifies the characteristics of each terminal in your communications network. You must supply one of these macros for each terminal or screen bypass terminal. Each TERM macro must be placed following the DCPCHNL, LINE, or VLINE macro that specifies the communications line to which the terminals are attached. You can only specify one TERM macro per LINE macro when defining UTS 20D local workstations, and two TERM macros for UTS 40D and SVT 1122 local workstations.

Table 2-27 describes the interface and type of network definition in which you may use this macro. It also details the applicability of each operand in the macro. The first line in the table is the name of the macro itself preceded by an asterisk (*) to distinguish it from its operands).

Format

LABEL	ΔOPERATIONA	OPERAND
term-name	TERM	FEATURES= ((TTY) ((DCT475) ((DCT500) ((DCT524) (DCT1000) (U100 [, { 960 }] (U200 [, { 1024 }] (U200 [, { 1536 }] (U200 [, { 1920 }] (U400 [, { 960 }] [, SBT] [, CP] [, CC] (U400 [, { 1024 }] [, SBT] [, CP] [, CC] (U400 [, { 1536 }] [, SBT] [, CP] [, CC] (U400 [, { 1920 }] [, SBT] [, CP] [, CC] (U20 [, { 960 }] [, SBT] [, CC] [, { PRIMARY }] (U20 [, { 1920 }] [, SBT] [, CC] [, { SECONDARY }] (U40 [, { 960 }] [, CC] [, { PRIMARY }] (U40 [, { 1920 }] [, CC] [, { SECONDARY }] (1122) (U400TE) (1004 [, { DLT3 }] (1004 [, { DLT1 }] (DCT2000 [, SBLK] [, { 80 }] (DCT2000 [, SBLK] [, { 128 }] (9200 [, { 96 }] [, { DLT3 }] (9200 [, { 120 }] [, { DLT1 }] (9200 [, { 132 }] [, { DLT1 }] (9300 [, { DLT3 }] (9300 [, { DLT1 }]

continued

TERM

LABEL	OPERATION	OPERAND
term-name	TERM (cont)	<pre> (((3780 2780 3780EM 2780EM BSC [,max-output-record-length] [, {max-no-records-per-block}] [, {MULTI}] [, {SECOND}] [,TRANSPARENT] [, {PRIMARY}] [,transparent-input-record-length]: [,max-block-length] [, {MODEL1}] [,NOSTX] {MODEL2} {MODEL3} {MODEL4} (IBSC, {IMS}, {MABT} [,PRI,TRANS] {TIP} {EOT} {,HRTB} (3271 [, {DISPLAY}] [, {1920}] [, {LAMP}] {PRINTER}] [, {480}]] [, {ALARM}] (3277, {PASS} {STRIP} {CONV} (TTYEM) [,CALL=phone-number] [,ADDR= ((rid,sid) (dev-addr) mn,nn)) [,PINTV= {tenths-of-seconds}] [,AUX1=(aux-dev-id),...,AUX44=(aux-dev-id)] [,INPUT= {name} [,blanks][,filename] {YES}] [,LOW= {filename} {MAIN}] [,MEDIUM= {filename} {MAIN}] [,HIGH= {filename} {MAIN}] [,ALTD=alt-dest] [,INTERCPT= {YES} {filename}] [,REMOTE= ((node-id (subname,PDN,[PT])))] [,DICE= ({ON} [, {NEWLINE}] {OFF} {FORMS})] </pre>

continued

LABEL	OPERATION	OPERAND
term-name	TERM (cont)	<pre> [,XLATE= (({ YES NO } label i ,idi) ({ YES NO } label o ,ido))] [,PROFIL=n] [,INHIBIT=YES] [,MSGWAIT=(message)] [,ANSWER=(int,C,text)] [,PLIMIT=integer] [,INONLY=YES] [,OUTONLY=YES] [,TCTUPD=YES] [,DISIN=n] [,DISOUT=n] [,INRECSZ= ({ 80 96 128 })] [,DVCGID=terminal-group-name] [,PROTYP= ({ DEV INT-1 RB-2 })] [,RBATCH= ({ NO YES })] [,SPR= ({ 60 seconds })] [,TIMEFILL=NO] [,SCREENS= (({ n s }) , [subtype])] [,DESPACE= ({ U Y N })] [,PSEUDO=Telcon-term-name] </pre>

Label

term-name

Is a 4-character label that identifies this terminal.

Notes:

1. When running in the DCA=YES environment with LPORT macro(s) specified, an A023 message may result in the SG\$COMMK assembly step if the first character of the label is Z.
2. If this terminal is defined by a TERM statement in a Telcon generation and the Telcon terminal name is greater than 4 characters and not more than 8 characters, use the PSEUDO keyword to match the terminal names correctly.

Table 2-27. Applicability of TERM Macroinstruction and Its Operands

Macro: TERM	ICAM Network Type and Kind of Program Supported										
	Direct Data Interface		Dedicated Networks			Global Networks					
Operand Name	DDI	RBP	TCI (IMS)	STDMCP	CMCS (COBOL)	STDMCP	TCI (IMS)	COBOL	DMI	††DCA	†Public Data Networks
	NTR										
*TERM	R	R	R	R	R	R	R	R	R	O	O
label	R	R	R	R	R	R	R	R	R	O	O
ADDR=	O	O	O	O	O	O	O	O	O	O	R
ALTD=	-	-	-	O	O	O	-	O	-	-	-
ANSWER=	O	O	O	O	O	O	O	O	-	-	-
AUX1=	O	O	O	O	-	O	O	-	O	O	O
•	-	-	-	-	-	-	-	-	-	-	-
•	-	-	-	-	-	-	-	-	-	-	-
AUX44=	O	O	O	O	-	O	O	-	O	O	O
CALL=	-	-	-	-	-	-	-	-	-	-	O†††
DESPACE=	-	-	-	-	-	-	-	-	O	O	O
DICE=	O	O	O	O	R	O	O	R	O	O	O
DISIN=	-	-	-	-	-	-	-	-	-	-	O†††
DISOUT=	-	-	-	-	-	-	-	-	-	-	O†††
DVCGID=	-	-	-	-	-	-	-	-	-	R	-
FEATURES=	R	R	R	R	R	R	R	R	R	R	R
HIGH=	-	-	O	O	O	O	O	O	-	-	O
INHIBIT=	O	-	-	O	O	O	-	O	O	-	-
INONLY	O	O	O	O	O	O	O	O	O	O	O
INPUT=	-	-	O	O	O	O	O	O	O	O	O

continued

Table 2-27. Applicability of TERM Macroinstruction and its Operands (cont.)

Macro: TERM	ICAM Network Type and Kind of Program Supported										
	Direct Data Interface		Dedicated Networks			Global Networks					
Operand Name	DDI	RBP	TCI (IMS)	STDMCP	CMCS (COBOL)	STDMCP	TCI (IMS)	COBOL	DMI	††DCA	†Public Data Networks
	NTR										
INRECSZ=	-	0	-	-	-	-	-	-	-	-	-
INTERCEPT=	-	-	-	0	0	0	-	0	-	-	-
LOW=	-	-	0	0	0	0	0	0	-	-	0
MEDIUM=	-	-	0	0	0	0	0	0	-	-	0
MSGWAIT=	0	-	0	0	-	0	0	-	-	-	-
OUTONLY=	0	0	0	0	0	0	0	0	0	0	0
PINTV=	0	0	0	0	0	0	0	0	0	0	-
PLIMIT	0	-	-	0	-	-	-	-	-	-	-
PROFIL=	-	-	0	0	0	0	0	0	-	-	-
PROTYP=	-	-	-	-	-	-	-	-	-	0	-
PSEUDO=	-	-	-	-	-	0	0	0	0	0	0
RBATCH=	-	-	-	-	-	-	-	-	-	0	-
REMOTE=	-	-	-	-	-	-	-	-	-	0	R
SCREENS=	-	-	0	0	0	0	0	0	0	0	0
SPR=	0	0	0	0	0	0	0	0	0	0	0
TCTUPD=	0	0	0	0	0	0	0	0	0	0	0
TIMEFILL=	-	-	0	0	0	0	0	0	0	-	-
XLATE	0	-	-	0	0	0	0	0	-	0	0

†Packet-switched only ††Also circuit-switched PDNs †††DATEX-L PDN only

LEGEND:

R = Required O = Optional - = Not applicable

Operands

FEATURES=

Identifies the characteristics of this terminal and the features supported.

Note: *These operands are positional. That is, if you do not specify an optional suboperand, you must code a comma to indicate the defaulted suboperand; except, do not specify a trailing comma.*

For example, you can code either of the following:

FEATURES=(U20,1024,SBT)

FEATURES=(U20,,,,PRIMARY)

(TTY)

Identifies this terminal as a teletypewriter or as a UTS 10 single station.

$\left(\begin{array}{l} \text{DCT475} \\ \text{DCT500} \\ \text{DCT524} \end{array} \right)$

Identifies this terminal as a 475, 500, or 524 Data Communications Terminal.

(DCT1000)

Identifies this terminal as a DCT 1000 Data Communications Terminal.

$\left(\text{U100} \left[, \left\{ \begin{array}{l} 960 \\ 1024 \end{array} \right\} \right] \right)$

Identifies this terminal as a UNISCOPE 100 Display Terminal or a UTS 400 operating similarly to a UNISCOPE terminal; set to display 960 or 1024 characters (12 x 80 or 16 x 64 screen). Also identifies a UDS 2000 operating in a UNISCOPE mode, or a V77 Series Data Processing System emulating a UNISCOPE 100 Display Terminal.

$\left(\text{U200} \left[, \left\{ \begin{array}{l} 1536 \\ 1920 \end{array} \right\} \right] \right)$

Identifies this terminal as a UNISCOPE 200 Display Terminal or a UTS 400 operating similarly to a UNISCOPE terminal; set to display 1536 or 1920 characters (24 x 64 or 24 x 80 screen).

Note: *For OS/3 to MAPPER 5 connectivity, you must specify FEATURES=(U200,1920).*

$$\left(U400 \left[\left\{ \begin{array}{l} 960 \\ 1024 \\ 1536 \\ 1920 \end{array} \right\} \right] [, SBT] \left[\left\{ \begin{array}{l} CP \\ PR \end{array} \right\} \right] [, CC] \right)$$

Specifies this terminal is a UTS 400 or UTS 4000 operating in the UTS 400 mode set to display 960, 1024, 1536, or 1920 characters. See Appendix B for details and examples of the U400 suboperand.

SBT

Specifies the screen bypass feature. The station address (*sid*) assigned must be one greater than the last terminal in the group (see ADDR operand).

CP

Specifies the U2 mode of the character protection feature, and that this terminal is configured as a UNISCOPE with up to 80 protection changes per line. Special function keys 5 - 22 are enabled and Katakana is disabled.

PR

Specifies PROTECT/FCC is set to PROTECT. Terminal is operated as a UNISCOPE but is limited to 15 protection changes per line. Special function keys 5 - 22 and Katakana are disabled.

Note: *If this terminal functions as a UTS 400 or UTS 4000, do not specify PR or CP.*

CC

Specifies this terminal as one of a UTS 400 cluster. A cluster is defined as two or more terminals attached to a UTS 400 controller, or one or more terminals attached to a master UTS 400 terminal.

Specify CC for all terminals in the cluster. Do *not* specify CC for a stand-alone master UTS 400 terminal or a UTS 400 controller with only one terminal.

(U20 [, { 1920 }] [, SBT] [, CC] [, { PRIMARY }] [, { SECONDARY }])

Specifies that this is a UTS 20 set to display 960 or 1920 characters. See Appendix B for details and examples of the U20 suboperand.

You can indicate U20 for the following devices:

- UTS 20
- SVT 1120, SVT 1123, SVT 1124
- PC using UNISCOPE emulation provided by STEP
- UNIX O/S UNISCOPE emulation provided by the Programmable Communications Controller
- UTS 20D local workstation (LWS)
- UTS 20W attached to a UTS 4020 or 4040 cluster controller

Notes:

1. *You can generate the SVT 1120, SVT 1123, and SVT 1124 as a UTS 20 or as a UTS 40.*
2. *You can define a UTS 20, SVT 1123, SVT 1124, and PC (utilizing STEP to provide UNISCOPE emulation) as a terminal or as a remote workstation.*
3. *A UTS 20D functions in a single-station mode. You must therefore define a LINE macro for each local workstation TERM macro. Since a UTS 20D is a single-screen device, it has no auxiliary printing or second-screen support.*
4. *PRIMARY/SECONDARY does not apply to a UTS 20D local workstation.*

SBT

Specifies that this terminal has the screen bypass feature. The *sid* assigned must be one greater than the last actual terminal in the group. (See ADDR operand).

CC

Specifies that this terminal is a UTS 20W workstation connected to a UTS 4020 or 4040 cluster controller. This operand is not used for workstations connected to a cluster controller in a public data network or for a single-station UTS 20 terminal (RWS).

PRIMARY/SECONDARY

Specifies the primary or secondary screen on a dual-screen device. If you don't specify this parameter, the device is considered single-screen. If you do specify it, you must also supply two TERM macros (one for each screen). The macro definitions are the same except the first TERM macro must specify PRIMARY and the second must specify SECONDARY.

The station address (*sid*) you specify for the second display screen must be one higher than the *sid* you specify for the primary display screen.

PRIMARY/SECONDARY need not be specified unless remote or terminal spooling is desired.

Notes:

1. *Auxiliary printer spooling support provided by the OS/3 operating system requires a dual-screen device. You must specify the PRIMARY/SECONDARY parameter to use this facility.*
2. *The I/OGEN section of the system generation parameters contains the statements REMWORKSTATION AMOUNT=n and SCRENMEM=m. Use these statements to indicate the maximum number of single- and dual-screen communications devices supported by interactive services on your OS/3 system. For example, if your system supports 10 single-screen UTS 20s and 5 dual-screen UTS 20s, include the following statements in your system generation parameters:*

```
REMWORKSTATION AMOUNT=10 SCRENMEM=1  
REMWORKSTATION AMOUNT=5 SCRENMEM=2
```

(U40 [, { 960 }] [, CC] [, { PRIMARY }] [, { SECONDARY }])

Specifies that this is a UTS 40 set to display 960 or 1920 characters. See Appendix B for details and examples of the U40 suboperand.

You can indicate U40 for the following devices:

- UTS 30, UTS 40
- SVT 1120, SVT 1123, SVT 1124
- PC using UNISCOPE emulation provided by STEP (level 2R1 or higher)
- UTS 40D local workstation (LWS)
- UTS 40W attached to a UTS 4020 or 4040 cluster controller

Notes:

1. *You can generate the SVT 1120, SVT 1123, and SVT 1124 as a UTS 20 or as a UTS 40.*
2. *You can define a UTS 30, UTS 40, SVT 1123, SVT 1124, and PC (utilizing STEP to provide UNISCOPE emulation) as a terminal or as a remote workstation.*
3. *A UTS 40D functions in a single-station mode. You must therefore define a LINE macro for each local workstation TERM macro. Since a UTS 40D is a dual-screen device, you must define two TERM macros in order for ICAM to use data mode on screen 2.*
4. *PRIMARY/SECONDARY does not apply to a UTS 40D local workstation.*

CC

Specifies this terminal as a UTS 40W workstation connected to a UTS 4020 or 4040 cluster controller.

Note: *Do not specify this operand for a packet-switched cluster controller in a PDN or for a single-station UTS 40 terminal (RWS).*

PRIMARY/SECONDARY

Specifies the primary or secondary screen on a dual-screen device. If you don't specify this parameter, the device is considered single-screen. If you specify the parameter, you must also supply two TERM macros (one for each screen). The macro definitions are the same except the first must specify PRIMARY and the second must specify SECONDARY. The station address (*sid*) you specify for the second display screen must be one higher than the *sid* you specify for the primary display screen.

PRIMARY/SECONDARY need not be specified unless remote or terminal spooling is desired.

Notes:

1. *Auxiliary printer spooling support provided by the OS/3 operating system requires a dual-screen device. You must specify the PRIMARY/SECONDARY parameter to use this facility.*
2. *The I/OGEN section of the system generation parameters contains the statements REMWORKSTATION AMOUNT=*n* and SCRENMEM=*m*. Use these statements to indicate the maximum number of single- and dual-screen communications devices supported by interactive services on your OS/3 system. For example, if your system supports 10 single-screen UTS 40s and 5 dual-screen UTS 40s, include the following statements in your system generation parameters:*

REMWORKSTATION AMOUNT=10 SCRENMEM=1
REMWORKSTATION AMOUNT=5 SCRENMEM=2

(1122)

Specifies that this is an SVT 1122 local workstation. Since the SVT 1122 is a dual-screen device, you must define two TERM macros in order for ICAM to use data mode on screen 2.

(U400TE)

Identifies this terminal as a UTS 400 text editor. The screen size is 1920 characters (24 x 80 characters).

(1004 [, , { DLT3 }]])

Identifies this terminal as a 1004 card processor system and the data line terminal (DLT1 or DLT3) used. The extra comma denotes an unused suboperand. This operand is also used to identify a V77 Series Data Processing System emulating a 1004 remote card processor system.

(DCT2000[, SBLK] [, { 80 }]])

Identifies this terminal as a DCT 2000 Data Communications Terminal and indicates the features it contains. SBLK indicates the terminal uses the short block feature. 128 indicates the terminal is set to receive and print 128 characters, rather than 80 characters.

(9200 [, { 96 }] [, { DLT3 }]])

Identifies this terminal as a 9200 system connected to ICAM as a communications terminal. 96, 120, or 132 identifies the length of a print line. DLT3 or DLT1 identifies the data line terminal used. The extra comma denotes an unused suboperand.

(9300 [, , { DLT3 }]])

Identifies this terminal as a 9300 system connected to ICAM as a communications terminal. DLT3 or DLT1 identifies the data line terminal used. The extra comma denotes an unused suboperand.

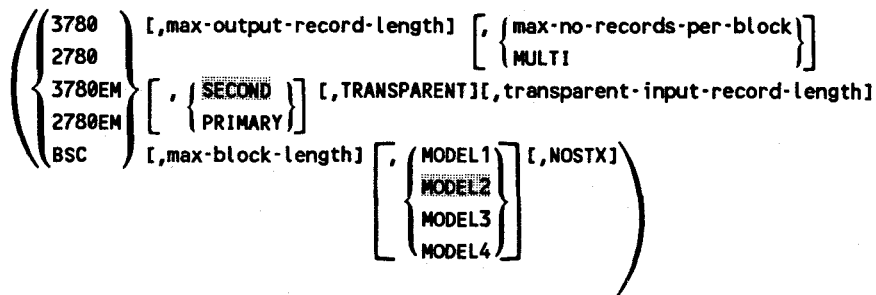

Establishes the requirements for binary synchronous communications as follows:

3780

Indicates that this terminal is an IBM 3780 or a UNIX O/S emulating an IBM 3780. When you use this operand, output blanks are space-compressed (except in transparent mode). When you specify only FEATURES=(3780), it defaults to FEATURES=(3780,80,2,SECOND).

2780

Indicates that this terminal is an IBM 2780 or 3741, or a UDS 2000 or UNIX O/S terminal emulating an IBM 2780. When you select this operand, all hardware requirements of the terminal are handled. This operand incorporates the terminal mode of the BSC remote device handler. If you specify only FEATURES=(2780), it defaults to FEATURES=(2780,80,2,SECOND).

3780EM

Indicates that the System 80 is emulating an IBM 3780 terminal.

2780EM

Indicates that the System 80 is emulating an IBM 2780 terminal.

BSC

Indicates that communications are between this computer and a remote computer or between this computer and any terminal that adheres to standard binary synchronous communications protocol (BSC). This operand incorporates the general mode of the BSC remote device handler. If you specify only FEATURES=(BSC), it defaults to FEATURES=(BSC,80,1,SECOND,,80,84).

max-output-record-length

Is a decimal number that specifies the output print line length. If you omit this suboperand, a value of 80 is used.

{max-no-records-per-block}
{MULTI}

Is a decimal number that specifies the maximum number of records that may be transmitted in a block. If you specify MULTI, 7 is used. If you do not specify this suboperand, 2 is used.

{ SECOND }
{ PRIMARY }

Specifies the remote device handler priority.

TRANSPARENT

Specifies this terminal includes the transparency feature. You may only specify this if you also specify `DEVICE=(BSC,,EBCDIC)` in the `LINE` macro.

transparent-input-record-length

Is a decimal number that specifies the fixed length of transparent input records. If you specify zero (0), single-record transparent input of arbitrary length is assumed. In this case, `ITB`, `DLE`, and `STX` characters are passed to your program if they are present in a message. If you omit this suboperand, 80 characters are assumed. This suboperand is valid only if you also specify the `TRANSPARENT` suboperand.

max-block-length

Is a decimal number that specifies the maximum number of characters (excluding `STX` and `DLE`) that can be sent in a block. If you specify 2780 or 3780, and do not specify this suboperand, 200 is assumed. If you specify 2780 or 3780 and the *max-no-records-per-block* suboperand as 2 or `MULTI`, and if you do not specify this operand, 400 is assumed.

{ MODEL 1 }
{ MODEL 2 }
{ MODEL 3 }
{ MODEL 4 }

Specifies the output devices available on this IBM 2780 terminal.

MODEL 1

Indicates the printer.

MODEL 2

Indicates a printer and a card punch.

MODEL 3

Indicates the printer (the terminal has no card reader).

MODEL 4

Indicates the card punch.

NOSTX

Specifies a `STX` character is inserted into the first record of multirecord messages. This suboperand is valid when `BSC` is specified and *max-no-records-per-block* is greater than one.

(IBSC, {IMS}, {WABT}, {TIP}, {EOT}, {HRTB}, PRI, TRANS)

IBSC

Indicates a remote CPU in inquiry/response session with an IMS/TIP30 LOCAP. (Not batch mode file transfer.)

{IMS}
{TIP}

Specifies the user program. IMS is the default.

{WABT}
{EOT}

Specifies the type of delay character the other CPU expects if ICAM must delay input due to lack of resources or an available input slot. Wait-a-bit (WABT) is the default.

HRTB

Displays the text message HRTB in order to notify the user program when a downed CPU comes back online. This is only operational in a dedicated CCA. In the dedicated CCA, you can also use the PINTV= parameter to specify a time delay before testing if the other CPU is back online.

PRI

Specifies that OS/3 ICAM is the primary station. Secondary is the default.

TRANS

Allows transparent text transfers. It is still the user's responsibility to specify transparent transfer of output to IMS/TIP30 (same as transparent aux print, but without an aux device).

(3271 [, { DISPLAY }] [, { 1920 }] [, { LAMP }])
 [, { PRINTER }] [, { 480 }] [, { ALARM }])

Identifies the terminal device as an IBM 3277 display station or 3284/3286 printer.

{ DISPLAY }
 { PRINTER }

DISPLAY specifies an IBM 3277 display station.
 PRINTER specifies an IBM 3284 or IBM 3286 printer.
 The default is DISPLAY.

{ 1920 }
 { 480 }

1920 and 480 refer to the screen size or print position size of the display station or printer. The default is 1920.

{ LAMP }
 { ALARM }

Specifies computer message waiting options.

LAMP

Specifies that the unsolicited message (USM) is sent to the display station by the remote device handler.

ALARM

Specifies that the remote device handler should send a message to actuate the audible alarm of the display station.

If omitted, a /CMW message is sent to the display station by the remote device handler. For the printer, this parameter is ignored.

(3277, {PASS
STRIP
CONV})

Identifies the terminal device as an emulated IBM 3277 display station.

PASS

On input and output, the message text is passed between your program and the IBM host with no modification performed. The DICE specification is ignored. The message text contains the IBM defined orders (i.e., set buffer address, attribute byte), and input messages contain the IBM command sequence.

STRIP

Provides for passing of unformatted (screen) data between your program and the IBM host. On input (from the IBM host), all IBM orders are stripped from the message; DICE is ignored. On output, the text is not modified. If you specify DICE=ON, the DICE sequence at the beginning of the message is converted to the cursor address.

CONV

Message text field control characteristics are converted between IBM attribute byte (ATB) orders and UTS 4000 field control character sequences. Conversion between DICE and set buffer address (SBA) is performed if DICE=ON. Conversion between all other IBM orders and UTS ESC sequences is performed as described in the *ICAM Standard MCP Interface Programming Guide* (UP-8550).

(TTYEM)

Identifies an uncontrolled, full-duplex, TTY-like device. Use this parameter when you specify DEVICE=(TTYEM) in the LINE macro. You may specify only one TERM macro for each TTYEM line.

CALL=phone-number

Specifies a numeric or alphanumeric telephone number used to dial a data terminal equipment (DTE) on a DATEX-L public data network.

ADDR= $\left(\begin{array}{l} \text{rid, sid} \\ \text{dev-addr} \\ \text{nn, nn} \end{array} \right)$

Identifies the remote identifier and station identifier for a specific terminal, the device address for a local workstation terminal, or the screen number for a packet-switched PDN UTS 4000 terminal.

ADDR=(rid, sid)

Is the hardware address of a polled terminal as wired into the terminal by field installation technicians. You must specify this operand for polled terminals such as:

- UNISCOPE 100/200 terminals
- UTS 400/4000 terminals (all versions)
- DCT 1000 terminals
- DCT 500 terminals operating in automatic mode
- IBM 3270 terminal systems
- IBM 3270 emulator

rid

Is two hexadecimal digits that identify the remote device address wired in the terminal. The allowable range of addresses is 21_{16} to $4F_{16}$. For IBM 3270 terminals, *rid* specifies the IBM control unit (cu) address.

sid

Is two hexadecimal digits that identify the station address wired in the terminal. The allowable range of addresses is 51_{16} to $6F_{16}$. For IBM 3270 terminals, *sid* specifies the IBM device (dev) address.

Notes:

1. *The rid/sid combination must be unique for each terminal on a line.*
2. *For DCT 500 terminals operating in automatic mode, rid/sid definitions must be unique for each terminal on a line. However, any ASCII value may be used.*

3. For UNISCOPE 100/200, UTS 400/4000, and DCT 1000 terminals using polling groups:

- All terminals in a polling group must have the same rid (sids within a polling group must be unique).
- TERM macros for terminals in a polling group must be contiguous in your network definition.

For example:

LINE ... Line macro for this line

TERM ... ADDR=(21,51) ... polling group 1 on this line, terminal 1

TERM ... ADDR=(21,52) ... polling group 1 on this line, terminal 2

TERM ... ADDR=(21,53) ... polling group 1 on this line, terminal 3

TERM ... ADDR=(22,51) ... polling group 2 on this line, terminal 1

TERM ... ADDR=(22,52) ... polling group 2 on this line, terminal 2

TERM ... ADDR=(22,53) ... polling group 2 on this line, terminal 3

4. For the UTS 400 terminals, each terminal in a polling group (master/slaves to terminal controller/slaves) must use the same rid. The sid for each terminal must be assigned in contiguous ascending order with the master (or the primary terminal) designated as the lowest value sid. If the screen bypass function is utilized, the sid designated for this function (specified in an additional TERM macro) must be the next available sid (one greater than the sid assigned to the last actual terminal in the group).
5. When specifying terminal addresses for the non-PDN UTS 20 (with screen bypass feature) and UTS 40, the dual-screens are separately addressed and require separate and distinct definitions. You must specify two TERM macros (each appropriately defining one rid, sid) for each UTS 40 and dual-screen UTS 20. The addresses must be consecutive. For example:

TR1A TERM ... ADDR=(35,51) ... SCREEN A

TR1B TERM ... ADDR=(35,52) ... SCREEN B

6. For OS/3 to MAPPER 5 connectivity, the rid, sid terminal address for the MAP5RDH line must correspond to the rid, sid terminal address definition configured on the MAPPER 5 system for the MAP5RDH line.
7. For IBM 3270 emulated terminals, the CU/DEV addresses identifying the IBM control unit and device addresses must match the addresses generated in the IBM host, and conform to the address values and sequences as specified for the IBM 3277 display station.

The following is a network definition for a global network that provides both LWS and user program (CUP1) session communication with the IBM host connected to the 3270 emulator on LNE1. It includes two local workstations (LWS3 and LWS4) and a communications line (LNE1) to the IBM host with two "pseudo" terminals (TRM1 and TRM2). The local workstations, LWS3 and LWS4, can establish dynamic sessions with TRM2. A static session is defined between TRM1 and CUP1. The IBM control unit address is C1, and the two terminal device addresses are TRM1 (40) and TRM2 (C1). The CU address must be the same for all displays on the line.

1

72

```

NET1   CCA   TYPE=(GBL,,S)
        BUFFERS 200,64,0,ARP=50
CUP1   LOCAP TYPE=(STDMCP),LOW=MAIN
LNE1   LINE  DEVICE=(INV3271),
        TYPE=(2400,SYNC),
        ID=11,
        XLATE=(NO,NO)
TRM1   TERM  FEATURES=(3277,STRIP),
        ADDR=(C1,40),
        LOW=MAIN,
        INPUT=CUP1,
        DICE=(ON)
TRM2   TERM  FEATURES=(3277),
        ADDR=(C1,C1),INPUT=(YES),
        LOW=MAIN,
        DICE=(OFF)
LNE2   LINE  DEVICE=(LWS),LBL=1200
LWS3   TERM  FEATURES=(U20),ADDR=(312),INPUT=(YES)
LNE3   LINE  DEVICE=(LWS),LBL=1200
LWS4   TERM  FEATURES=(U20),ADDR=(313),INPUT=(YES)
        SESSION EU1=(CUP1),EU2=(TRM1)
        ENDCCA
    
```

ADDR=(dev-addr)

Identifies a specific local workstation terminal address allocated to ICAM.

For Models 4 and 6, the allowable addresses are 311-318, 331-338, 341-348, 351-358, 361-368, 371-378, and 381-388. Your hardware configuration determines the actual optional device addresses in the 340, 350, 360, and 370 ranges. For more details, see the *Hardware and Software Programming Quick-Reference Guide* (UP-8868).

For Models 8, 10, 15, and 20, the allowable addresses are C11-C18, C31-C38, C41-C48, C51-C58, C61-C68, C71-C78 C81-C88, E11-E18, E31-E38, E41-E48, E51-E58, E61-E68, E71-E78 and E81-E88.

For dual-screen local workstations (UTS 40D and SVT 1122), two TERM macros may be specified for the LINE. Each TERM macro on a given line should have the same ADDR value. For example:

1

72

```

LNE3  LINE  DEVICE=(LWS),LBL=1200
C11A  TERM  FEATURES=(U40),ADDR=(C11),INPUT=(YES),LOW=MAIN
C11B  TERM  FEATURES=(U40),ADDR=(C11),INPUT=(YES),LOW=MAIN

```

ADDR=(nn,nn)

The UTS 20(W) and UTS 40(W) workstations attached to the UTS 4020 or UTS 4040 in a packet-switched public data network are addressed by screen number. The number consists of a 2-digit ASCII number that represents a decimal equivalent as follows:

30,31 = 1
 30,32 = 2
 30,39 = 9
 31,30 = 10

Note: Do not specify the ADDR operand for single-station teletypewriters, such as the DCT 500 or the UTS 10.

PINTV=tenths-of-seconds

Is the time in tenths-of-seconds between polls to this terminal. You may specify a value from 1 to 2550 (1/10 second to 255 seconds). This operand applies to UNISCOPE 100/200, DCT 1000, and UTS 400/4000 terminals and IBM 3270 terminal system. If you use polling groups, only the time specified for the first terminal in the polling group is used; if you specify PINTV for a subsequent terminal in the same polling group, this operand is ignored.

A polling timer is established for each terminal or group of terminals (that is, a polling group) in a network definition. Each of these polling timers is incremented at a fixed interval. This interval is 0.1, 0.2, 0.5, or 1 second depending on the smallest interval you specify for any terminal in the network.

For example, if you define a network of two terminals and specify PINTV=50 for the first terminal and PINTV=53 for the second, the first terminal is polled every 5 seconds and the second every 6 seconds. This is because the basic timer interval is 1 second and the 5.3-second specification (PINTV=53) is rounded to 6 seconds. If, however, you added a third terminal to the network to be polled every 0.1 second (PINTV=10), the basic timer interval would be 0.1 second and all three terminals would be polled as specified; that is, 5, 5.3, and 0.1 second intervals, respectively.

If you specify the smallest PINTV value and make a syntax error (such as specifying an alphabetic character), system generation displays the message INVALID PARAMETER VALUE. However, if you specify the smallest PINTV value as an invalid number (for example, PINTV=3), no error message is displayed. In both cases, a polling increment of 1 second is used.

AUX1=(aux-dev-id)[, ..., AUX44=(aux-dev-id)]

The AUX n operands specify device addresses (*dids*) for auxiliary devices connected to this terminal. All terminals associated with ICAM include at least one input and/or output device, which is considered the primary device for I/O operations. You do not specify this operand for these primary devices. However, in addition to the primary device, a terminal may also support a number of secondary devices, known as auxiliary devices. You use this operand to identify these auxiliary devices.

Note: To use terminal spooling, you must have a dual-screen terminal defined as two terminals: one primary and one secondary. The AUX operand must be specified on both TERM definitions.

AUX1 through AUX44 create a displacement table of *dids* for auxiliary devices connected to this terminal. In your communications user program, use the n value of the AUX n operand in the device field (TM#DDVC) of a destination DTFCP when you issue a PUTCP request to send a message to an auxiliary device. In addition, the n value is placed in the TM#PDVC field of an input DTFCP by ICAM to indicate the auxiliary device that sent the message when you access a message by means of a GETCP.

You must specify the AUX n operands in sequential order, for example, from AUX1 to AUX12 (if 12 are necessary). The exception is when you specify the tape drives on a tape cassette system. Each device requires two *dids*, but you only specify one n , even though two are used. For example, for a tape drive, you might specify AUX1=(TCS,73,74). The second drive would be defined as AUX3=(TCS,75,76). Notice that AUX2 was not specified, and that the next available AUX n is 5.

How you define the auxiliary devices on your terminals depends upon the kind of terminal you have. The following describes how you specify the possible device addresses for each type of terminal supported by ICAM.

- **DCT 1000**

The primary input and output devices for the DCT 1000 terminal are the keyboard and printer. In addition, up to three auxiliary devices can be defined for a DCT 1000 terminal. The AUX n parameter is:

$$\text{AUX}_n = \left(\begin{array}{c} \text{PTP} \\ \text{PTR} \\ \text{PCH} \\ \text{RDR} \\ \text{PRNTR} \end{array} \right)$$

where:

- PTP Identifies the paper tape punch.
- PTR Identifies the paper tape reader.
- PCH Identifies the card punch.
- RDR Identifies the card reader.
- PRNTR Identifies the auxiliary printer.

The following values are substituted for the designated parameters:

Device Parameter	Device Address (Hex.) Wired in DCT 1000
PTP	7D
PTR	7C
PCH	7B
RDR	7A
PRNTR	7F

- UNISCOPE/UTS 400/UTS 20/UTS 30/UTS 40/Remote Workstations/PC/SVT 1120/SVT 1123/SVT 1124

The primary input/output devices are the keyboard and printer. The allowable range for auxiliary device addresses is 73_{16} to $7E_{16}$; (70_{16} , 71_{16} , 72_{16} , and $7F_{16}$ are reserved). The additional device addresses 20_{16} to $6F_{16}$ may be specified to designate auxiliary devices attached to a UTS 4000 terminal.

The device address of the auxiliary printer connected to the SVT 1120, SVT 1123, or SVT 1124 is 73_{16} .

The AUX n operand is used as follows:

For printers:

$$AUX_n = \left(\begin{matrix} COP \\ CQP \\ TP \end{matrix} \right), did$$

where:

- COP Identifies the communications output printer or the 0786 printer subsystem, the 0797 printer subsystem, or the 0798 printer subsystem.

- CQP Identifies the 0791 correspondence quality printer subsystem.
- TP Identifies the 800 terminal printer only.
- did Specifies two hexadecimal digits giving the device address in the printer.

For diskette or tape cassette:

AUX n =(TCS, did₁, did₂)
 Identifies one of the two cassette drives (n) on the cassette subsystem, regardless of the type of operation ($n + 1$ is also valid except for write operations).

TCS Identifies a tape cassette system (TCS) or diskette subsystem for the UTS 400 or UNISCOPE, or a diskette for the UTS 4000.

did₁ Specifies two hexadecimal digits giving the output device (write) address in the TCS for one of the two drives.

did₂ Specifies two hexadecimal digits giving the input device (read) address in the TCS for the same drive.

Note: *Diskette or tape cassette subsystems are not supported for remote workstations.*

The following example shows a network definition that supports a UTS 400 terminal. As you can see in the TERM macro definition, the UTS 400 terminal supports two COP printers and two tape cassette systems (4 drives). Note how each AUX n parameter relates to the number of *did*s specified.

1		72
<hr/>		
U400	CCA TYPE=(STDMCP), CCAID=U400 BUFFERS 16,64,2, ARP=40	
LN01	LINE DEVICE=(UNISCOPE), TYPE=(9600, SYNC), ID=8, LBL=64, INPUT=YES	X
TM01	TERM FEATURES=(U400, 1920), HIGH=MAIN, MEDIUM=MAIN, LOW=MAIN, ADDR=(21, 54), AUX1=(COP, 73), AUX2=(COP, 74), AUX3=(TCS, 75, 76), AUX5=(TCS, 77, 78), AUX7=(TCS, 79, 7A), AUX9=(TCS, 7B, 7C)	X X X
PRF1	PRCS LOW=MAIN, MEDIUM=MAIN, HIGH=MAIN ENDCCA	

- **DCT 500, DCT 524, DCT 475, and TTY**

In addition to the primary input and output devices of the keyboard and the printer, the DCT 500, DCT 475, and TTY supply auxiliary device support for the paper tape reader and punch. The DCT 524 supplies auxiliary device support for the write and read cassette systems.

$$AUX_n = \left(\begin{array}{l} \text{PTP} \\ \text{PTR} \end{array} \right)$$

where:

PTP
Identifies the paper tape punch or the cassette write head for the DCT 524.

PTR
Identifies the paper tape reader or the cassette read head for the DCT 524.

The following values are substituted for the designated parameters:

Device Parameter	Device Address (Hex.) Wired in DCT 500
PTP	75
PTR	76

- **DCT 2000, 1004 card processor, and 9200 and 9300 systems**

The primary input and output devices for the DCT 2000 and the 1004 card processor are the card reader and page printer. In addition, the DCT 2000, the 1004 card processor, the 9200 system, and the 9300 system provide auxiliary device support for a single card punch.

For these systems, the AUX_n parameter is:

$$AUX_1 = (\text{PCH})$$

where:

PCH
Identifies the card punch.

- **UTS 40D (model II) local workstation/SVT 1122**

You may specify up to four printers (PRNTR) attached to a UTS 40D, but only one printer (PRNTR) attached to an SVT 1122.

AUXn=(PRNTR)

where:

n
Is 1 to 4.

Notes:

1. *You may not specify auxiliary printers for UTS 20 local workstations.*
2. *For a printer attached to a UTS 40D or SVT 1122 local workstation, wait 60 seconds after input for notification of start of printing (timeout) before checking on the printer.*
3. *For OS/3 to MAPPER 5 connectivity, only auxiliary printers are supported for the AUXn operand.*
4. *For dual-screen devices, printing is done through the second screen. Printing cannot occur if the second screen is already allocated to ICAM (that is, a session is established between the screen 2 TERM and a LOCAP.*

INPUT= ((name) [,blanks][,filename]
(YES)

Establishes a destination for messages input at this terminal.

Note: *You must specify the INPUT operand for each terminal on a line - either here or in a LINE macro for the line to which this terminal is connected. If you specify this operand in both the LINE and the TERM macros, the TERM destination is used.*

name

Is a 1- to 4-character name that matches the label of a LOCAP, PRCS, MPPS, or TERM macro. This is the name you address on GETTCP calls to a process file or a LOCAP file to retrieve input messages from this terminal. Depending on the name you specify, input messages from this terminal are directed to:

- the low priority queue of a communications user program defined by the label of a LOCAP macro (global networks only)

- the low priority queue of a process file, defined by the label of a PRCS macro
- the low priority queue of a terminal, defined by the label of a TERM macro (this causes message switching because a message, input from a terminal on this line, is immediately placed on the output queue of another terminal)
- a destination determined by MPPS, with the name of the routine defined by the label of an MPPS macro. This is the only destination you may specify for the transaction control interface.

YES

Creates an input message queue for this terminal. If you also include the filename suboperand, input messages are held in a disk file until your program accesses them. If you omit the filename, a main storage input message queue is established. Your program accesses a message placed on this input message queue by issuing a GETCP macro, and in the related DTFCP, specifying the name of this TERM macro. You do not need to specify a priority.

Use INPUT=YES when you specify FEATURES=(TTYEM) on the TERM macro.

blanks

Is a decimal value from 1 to 255 that indicates the number of bytes (blank characters) you want reserved in front of each input message for MPPS or your program's insertion of data.

filename

Is a 1- to 7-character name of a disk file where messages input from this terminal are stored until your program accesses them. The filename must match the label of a DISCFILE macro. Include this suboperand only if you also specify YES.

LOW, MEDIUM, and HIGH

These operands create priority terminal output queues in main storage or on disk for this terminal. They override any you create by means of the LOW, MEDIUM, and HIGH operands in the LINE macro.

LOW=filename

Creates a low priority output queue for this terminal on a disk file you name in a DISCFILE macro.

LOW=MAIN

Creates a low priority output queue for this terminal in main storage.

MEDIUM=filename

Creates a medium priority output queue for this terminal on a disk file you name in a DISCFILE macro.

MEDIUM=MAIN

Creates a medium priority output queue for this terminal in main storage.

Note: If this operand is omitted, a medium priority queue is not created.

HIGH=filename

Creates a high priority output queue for this terminal on a disk file you name in a DISCFILE macro.

HIGH=MAIN

Creates a high priority output queue for this terminal in main storage.

Note: If this operand is omitted, a high priority queue is not created.

ALTD=alt-dest

Defines the label of an alternate process file, terminal, or LOCAP where you want output messages sent if this terminal is unable to receive them.

If this terminal is marked down by ICAM before ICAM dequeues the output and you have specified ALTD, ICAM sends the message to the alternate destination. If ALTD is not specified, but an intercept queue is available (see INTERCPT operand), ICAM places the message on the intercept queue.

In addition, if you have a message processing (MPPS) routine in your network, this is the name of the alternate destination (ALTD) your MPPS routine may refer to in a DIRECT, REROUTI, or REROUTO macro.

If the terminal is marked down during the actual output processing of a given message, the ALTD param on the TERM macro will not be referenced at this time by ICAM, unless the MPPS REROUTO with ALTD operand is executed.

Notes:

1. *Alternate destinations (ALTD) must not form a loop (terminals designating each other as alternatives); otherwise, system looping can occur.*
2. *ALTD cannot redirect multiple destination messages queued in main storage. However, any multiple destination message going to all disk queues may be redirected.*
3. *ALTD cannot be specified for a remote workstation.*

```
INTERCPT= { YES
           { filename }
```

YES creates a main storage intercept queue for output messages for this terminal when you use line queueing for output messages. If you specify *filename*, the intercept queue is placed on a disk file you identify by means of the label of a DISCFIL macro. The intercept queue can be used by ICAM or by a message processing routine to temporarily store messages. If you have a message processing routine, and it detects an error in an output message to this terminal (such as a bad destination), it can send the message to this intercept queue where it is held until your program releases the intercept queue by means of a RELEASM macro.

Both ICAM and your message processing routine can send messages to an intercept queue for line/terminal-down situations, if you don't have an alternate destination specified (see ALTD operand). However, when the destination terminal becomes operable, ICAM automatically releases any messages held on the intercept queue. If you do not specify this operand, an intercept queue is not created for this terminal.

Notes:

1. *Multiple destination messages can be redirected to an intercept queue only if they are on disk.*
2. *You must specify line queueing to use this feature.*

```
REMOTE=(node-id)
```

Specifies the remote node to which this terminal is connected. This operand is a 1- to 4-character name that must be the same as the destination node specified in the LPORT statement.

```
REMOTE=(subname,PDN,[PT])
```

For packet-switched public data networks only, specifies that this is either a terminal attached to a remote host or a workstation attached to a UTS 4000 series packet-switched cluster controller.

Terminals or workstations in these categories must be defined with their TERM macros following the SUB macro defining their common subscriber.

subname

Specifies the symbolic name of the SUB macro that defines the remote host or cluster controller for this terminal or workstation.

PDN

Specifies that this is a public data network user.

PT

Specifies that this terminal is a workstation attached to a cluster controller. This operand is not used for terminals attached to a remote host.

DICE= ({ ON } , { NEWLINE }
 { OFF } , { FORMS })

Describes how you want device independent control expressions (DICE) used with this terminal. If you do not specify this operand, DICE=(ON,NEWLINE) is assumed.

ON

Indicates that the ICAM remote device handler places DICE into all input messages.

OFF

Indicates that DICE characters are not placed in input messages.

NEWLINE

Indicates that on output, a set coordinates or a forms control with clear DICE is converted to a new line positional control DICE with the DICE *m* field equal to 00₁₆ and the *n* field equal to 00₁₆.

FORMS

Indicates that on output, a set coordinates DICE is converted to a forms control DICE.

Notes:

1. *NEWLINE* and *FORMS* apply to all devices except cathode ray tube devices and the COBOL message control system (CMCS). *NEWLINE* is always assumed for the IBM 3270 terminal system since the IBM 3284/3286 printers do not have a form-feed function.
2. You must specify DICE=(ON) when using the COBOL message control system.
3. You must specify DICE=(OFF) when you use FEATURES=(TTYEM) on the TERM macro.

XLATE= (({ YES }
 { NO }
 { label i, idi }) [, { YES }
 { NO }
 { label o, ido }])

The XLATE operand lets you specify the translation table you want to use for input from this terminal and also the one you want to use for output going to this terminal. You can write your own translation tables, use those supplied by ICAM, or specify that you want no translation at all. If you omit this operand entirely, the translation tables established for this line, by means of the LINE macro, are used. (For a discussion of how to generate translation tables, see Section 4.)

For IBM 3270 terminal systems or local workstations with Katakana support, specify XLATE=(NO,NO). See DEVICE=(LWS,KA) in the LINE macro.

For a TTYEM device, specify XLATE=(NO,NO).

The XLATE operand is divided into two similar suboperands; the first suboperand is concerned with input translation, and the second is concerned with output translation.

Input translation is specified as:

YES

Indicates that the standard translation table is used for input from this terminal.

NO

Indicates that no translation takes place for input received from this terminal.

labeli

Specifies the name of a user-supplied input translation table. The name specified must correspond to that specified for a user-generated translation table assembled in this network.

idi

Is a decimal number, 1 to 240, identifying a user-generated input translation table within this network. This number makes it easy for ICAM to tell whether the same input translation table already exists in the network. If the same number is used with a different *labeli* name, the table name used is the last one specified. The same input translation table may be identified in any number of LINE or TERM macros.

The default is the input translation table defined for this line (by means of the LINE macro) with which this terminal is associated.

Output translation is specified as:

YES

Indicates that the standard translation table is used for output to this terminal.

NO

Means that output to this terminal is not translated.

labelo

Specifies the name of a user-supplied output translation table for this terminal. The name specified must correspond to that specified for a user-generated translation table assembled in this network.

ido

Is a decimal number, 1 to 240, that identifies a user-generated output translation table assembled within this network. This number helps ICAM tell whether the same output translation table already exists in the network. If the same number is used with another *labelo* name, the table name used is the last one specified. You may specify the same output translation table in any number of LINE or TERM macros.

The default is the output translation table defined for this line (by means of the LINE macro) with which this terminal is associated.

Notes:

1. *The XLATE operand specified by means of the LINE macro is used for all terminals on this line for which an XLATE operand is not specified. If you specify an XLATE operand in this macro, it overrides the line information for this terminal only.*
2. *The idi and ido suboperands refer to separate input and output translation tables; that is, you may specify up to 240 input translation tables and 240 output translation tables.*
3. *You include any translation tables of your own at the end of your network definition before the ENDCCA macro.*
4. *Continuation of assembler DC statements is not acceptable; therefore, each DC statement should have a closing apostrophe in column 71 or before.*
5. *Standard translation tables are either 128 or 256 bytes long; your tables should normally be one of these two lengths.*

PROFIL=n

Assigns a profile number used with the message format editing facility. The number you assign must agree with one you assign in an EUP macro by means of its PRFN operand.

Note: *If you use the same editing profile for several terminals, you must specify multiple EUP macros and assign a different PRFN number to each. You cannot specify the same physical profile to more than one terminal.*

INHIBIT=YES

Indicates ICAM is to ignore all subsequent input from this terminal following successful input of a message. This inhibition remains in force until a successful output transmission is completed. Any messages sent from this terminal following the first successful one are lost. This allows you to set up an inquiry/response relationship with this terminal; that is, one message is followed by a single response.

MSGWAIT=(message)

Defines a 4-character *computer message waiting* message that is sent to this terminal to inform the terminal operator of a waiting message. The terminal operator must respond with BEL (control G) and ETX (control C) before the waiting message is sent to the terminal. It is ignored for IBM 3270 terminals.

This operand is only used with DCT 475, DCT 500, DCT 524, or TTY terminals. It is ignored for IBM 3270 terminals.

If you do not specify this operand, the message /CMW is used, but you can specify any 4-character message.

Note: No carriage return or line feed characters accompany the default message. However, they can be inserted as the first or last two characters of the 4-character message operand, leaving two printable characters in the message. This can be accomplished by multipunching carriage return (0-9-5) and line feed (12-9-8-5) or by multipunching a DICE expression with a DLE (12-11-9-8-1) and the function code for new line (4). In either situation, the remote device handler inserts appropriate time fill for carriage return and line feed.

ANSWER=(integer,C,text)

Specifies a site identification constant that ICAM can use to verify site identifier codes (site IDs) for 1004, 9200, or 9300 systems.

integer

Indicates the number of bytes represented by the third suboperand (text).

C

Indicates the text suboperand consists of printable characters.

text

Is the alphanumeric site identifier. The number of characters you specify must be the same as specified in the integer suboperand.

PLIMIT=integer

Is the maximum number of messages to be accepted from this terminal in a single polling pass. If you omit this parameter, all messages ready for transmission are accepted. This operand is used for polled terminals serviced by a remote device handler you write yourself. Do not specify this operand if you are using a remote device handler supplied by Unisys.

INONLY=YES

Specifies that this terminal is a send-only device; that is, traffic always flows from the terminal to ICAM.

OUTONLY=YES

Specifies that this terminal is a receive-only device; that is, traffic always flows from ICAM to the terminal.

TCTUPD=YES

Specifies this UNISCOPE terminal can communicate with OS/3 interactive services and another program such as IMS or a user-written program when signed on (\$\$SON) to dynamic sessions (a LOCAP macro specified as TYPE=DMI).

Do not specify this operand if this macro defines a local or remote workstation.

This operand controls the DICE status and translation tables used between this terminal and interactive services. If you specify TCTUPD=YES, ICAM uses the proper DICE status and translation tables when you sign on to interactive services. When you sign on to your user program or IMS, ICAM uses the DICE status and translation tables you specify in the DICE= and XLATE= operands.

DISIN=n

This operand applies only to DATEX-L circuit-switched public data networks. Specifies the time, in poll interval periods, that a terminal remains connected to the network after a message is received (see PINTV keyword). If omitted, the terminal is disconnected immediately after the completed message is received and acknowledged.

DISOUT=n

This operand applies only to DATEX-L circuit-switched public data networks. Specifies the time, in poll interval periods, that a terminal remains connected to the network after a message is transmitted. If omitted, the terminal is disconnected from the network immediately after the message is transmitted and acknowledged.

INRECSZ= $\left\{ \begin{array}{l} 80 \\ 96 \\ 128 \end{array} \right\}$

Specifies the input record size for a batch terminal in bytes. It is valid only for the following devices:

- Unisys DCT 2000, 1004 (REM1), 9200, 9300 (REM1), DCT 1000 (batch), BSC
- IBM 2780, IBM 3780, UNIX O/S emulating an IBM 2780 or 3780

Note: The INRECSZ operand must not be used in conjunction with the REMOTE operand.

DVCGID=terminal-group-name

Specifies the name of a remote terminal group in a DCA multinode or Telcon environment. The DVCGID operand must be one of the following names:

Interactive Terminals: INT33 for UNISCOPE
 INT41 for UTS 400
 INT51 for all others

PROTYP= { DEV
 INT-1
 RB-2 }

Describes how data is presented by the terminal. DEV specifies device dependent for terminals attached to a remote OS/3 host. INT-1 and RB-2 specify interactive or batch terminals respectively attached to a distributed communications processor.

RBATCH= { NO
 YES }

Indicates that this terminal is used for remote batch jobs. If omitted, interactive is assumed. When RBATCH=YES is specified, the operand XLATE=(NO,NO) must be specified if the batch terminals are attached to a distributed communications processor.

SPR= { 60
 seconds }

Specifies the slow polling interval for a downed polling group in seconds. Specify a value from 1-4095. If not specified, a value of 60 is used. This operand applies to UNISCOPE lines only, and need only be specified on the first terminal in each polling group.

SCREENS= (([n]
 [s]) [, subtype])

n

Specifies the number of screens that are supported by this "master" terminal, including the master terminal screen. If no extra screens are supported by this TERM macro, omit this keyword and a default value of 1 will be assumed.

s

Specifies that this terminal is a screen supported by a master terminal. Each screen supported by a master terminal must have its own TERM macro.

Notes: *The purpose of this keyword is to mark down all the terminals supported by the "master" terminal (including the master) when any one of them is marked down. When any one of these terminals is marked up, they all will be marked up. For example, assume a terminal has been configured to support three screens:*

1			72
<hr/>			
TRM1	TERM	FEATURES=(U20,1920),	X
		ADDR=(28,51),	X
		SCREENS=(3),...	X
TRM2	TERM	FEATURES=(U20,1920),	X
		ADDR=(28,52),	X
		SCREENS=(S),...	X
TRM3	TERM	FEATURES=(U20,1920),	X
		ADDR=(28,53),	X
		SCREENS=(S),...	X

subtype

This parameter lets you define the true device type specified by the generic U20/U40 specification within the FEATURES= parameter. This may allow ICAM users to take advantage of additional functionality. (This information will be made available with the TCI interface.)

This parameter may be specified for terminals on a UNISCOPE, RWS, DCPCHNL, or VLINE. Valid subtypes are:

- 1120
- 1123
- 1124
- PC
- OFIS[®] Link
- UNIX
- UTS30
- UTS60
- VIPS

If you do not specify a subtype, the terminal is treated as a true U20 or U40 device.

OFIS is a registered trademark of Unisys Corporation.

DESPACE=

Specifies the action to be taken by ICAM or interactive services for loading the destructive space specification of the control page. This parameter applies only to remote workstations, UNISCOPE terminals, and UNISCOPE-like devices attached to a DCP.

DESPACE=U

The destructive space parameter is not to be altered (that is, it remains set as previously specified in the control page). This is the default value.

DESPACE=Y

The destructive space parameter is set each time ICAM or interactive services loads the control page.

DESPACE=N

The non-destructive space parameter is set each time ICAM or interactive services loads the control page.

Notes:

1. *The DESPACE parameter on the TERM macro overrides the DESPACE parameter on the LINE and CCA macros for this terminal only.*
2. *The release 12.0 enhancement for ICAM destructive space definition is restricted for use by terminals located on a cluster controller, which are not loaded with the correct ICAM gen specification for DESPACE=U/Y/N. To obtain the desired destructive space setting, you must manually change the control page specification or use the interactive services SCREEN command.*

TIMEFILL=NO

Specifies that no time fill characters will be inserted into an output message after FCC or ESC sequences. If this parameter is omitted, time fill characters are inserted for these sequences according to the line speed. This parameter applies only to remote workstations and UNISCOPE terminals.

PSEUDO=tel con-term-name

Matches the terminal name specified in a Telcon generation where the terminal name is greater than 4 characters but less than or equal to 8 characters. Do not use this keyword if only 4 characters are used, as it would only create more processing.

2.26. How to Define a Trunk in a Packet-Switched Public Data Network (TRUNK)

This macro declares the name and attributes of the logical link between a packet-switched public data network (the data circuit-terminating equipment (DCE)) and the local subscriber (the data terminal equipment (DTE)). You may specify multiple trunks; however, each trunk must have a unique call number (DTE address). You determine the number of trunks you need when you subscribe to the PDN.

The TRUNK macro must follow the PDN macro in your network definition.

Table 2-28 describes the interface and type of network definition in which you may use this macro. It also details the applicability of each operand in the macro. The first line in the table is the name of the macro itself preceded by an asterisk (to distinguish it from its operands).

Format

LABEL	AOPERATIONA	OPERAND
symbol	TRUNK	CALLNO=dte-address [,PVC= { n }] [,ISVC= { n }] [,IOSVC= { n }] [,OSVC= { n }] [,DATATIM= { n }] [,WS=window-size]

Label

symbol

Is a 1- to 4-character label used to reference this macro.

Operands

CALLNO=dte-address

Specifies the level 3 DTE address of the local subscriber. You obtain this information from the PDN at subscription time. Note that this is not the DTE address of the remote subscriber defined in the SUB macro.

Table 2-28. Applicability of TRUNK Macroinstruction and Its Operands

Macro: TRUNK	ICAM Network Type and Kind of Program Supported											
	Operand Name	Direct Data Interface		Dedicated Networks			Global Networks					
		DDI	RBP	TCI (IMS)	STDMCP	CMCS (COBOL)	STDMCP	TCI (IMS)	COBOL	DMI	DCA	†Public Data Networks
*TRUNK	-	-	-	-	-	-	-	-	-	-	R	
label	-	-	-	-	-	-	-	-	-	-	R	
CALLNO=	-	-	-	-	-	-	-	-	-	-	R	
DATATIM=	-	-	-	-	-	-	-	-	-	-	O	
IOSVC=	-	-	-	-	-	-	-	-	-	-	O	
ISVC=	-	-	-	-	-	-	-	-	-	-	O	
OSVC=	-	-	-	-	-	-	-	-	-	-	O	
PVC=	-	-	-	-	-	-	-	-	-	-	O	
WS=	-	-	-	-	-	-	-	-	-	-	O	

*Shows macro applicability

†Packet-switched only.

LEGEND:

R = Required O = Optional - = Not Applicable

$$PVC = \begin{Bmatrix} n \\ q \end{Bmatrix}$$

Specifies the number of permanent virtual circuits provided by the PDN at subscription time. This number must agree with the number of PVC macros you specify for this trunk and the number of permanent virtual circuits that can handle data assigned at subscription time.

Valid values for the PVC operand are 0-4095; however, for DATAPAC, DATEX, and IBERPAC, do not include logical channel 0 in the count. Although channel 0 is provided in these networks, it is used for control purposes only and is not usable for data. The PVC operand is not valid for the DDX and PSS networks.

ISVC= $\left\{ \begin{matrix} n \\ 0 \end{matrix} \right\}$

Specifies the number of incoming switched virtual circuits to receive incoming calls only. You determine this value at subscription time.

Valid values for this operand are 0-4095 for all networks except DDX and PSS. The ISVC operand is not valid for the DDX and PSS networks.

IOSVC= $\left\{ \begin{matrix} n \\ 0 \end{matrix} \right\}$

Specifies the number of switched virtual circuits that have the capability to receive incoming calls from a remote subscriber and also have the capability to send outgoing calls to remote subscribers. You determine this value at subscription time.

Valid values for this operand are 0-4095 for all networks except DDX and PSS. The IOSVC operand is not valid for the DDX or PSS network.

OSVC= $\left\{ \begin{matrix} n \\ 0 \end{matrix} \right\}$

Specifies the number of switched virtual circuits that are used to make outgoing calls only. You determine this value at subscription time.

Valid values for this operand are 0-4095 for all networks except DDX and PSS. The OSVC operand is not valid for the DDX or PSS network.

DATATIM= $\left\{ \begin{matrix} nnn \\ 10 \end{matrix} \right\}$

Specifies the level 3 timeout value in seconds for a data packet. Valid values are 1 to 120 seconds for all public data networks.

WS=window-size

Specifies the level 3 window size for flow control of both input and output data packets. It applies to both switched and permanent virtual circuits on this trunk. Specify a value of 1 to 6 for TRANSPAC, DATAPAC, or DATEX-P. The WS operand is not used for DDX, IBERPAC, and PSS. Default values are as follows:

DATAPAC	4
DATEX-P	4
DDX	not used
IBERPAC	not used
PSS	not used
TRANSPAC	2

2.27. How to Define a Virtual Circuit Group in a DDX or PSS Packet-Switched Public Data Network (VCGROUP)

This macro defines the attributes of a permanent or switched virtual circuit group on a DDX or PSS packet-switched PDN for the most recently defined trunk macro.

Table 2-29 describes the interface and type of network definition in which you may use this macro. It also details the applicability of each operand in the macro. The first line in the table is the name of the macro itself preceded by an asterisk (to distinguish it from its operands).

Format

LABEL	OPERAND	OPERAND
symbol	VCGROUP	LCGN=group-number ,TYPE= { PVC ISVC OSVC IOSVC } ,NUMBER=n

Label

symbol

Is a required 1- to 4-character label used to reference this macro.

Operands

LCGN=group-number

Specifies the logical channel group number of this group.

For DDX you must specify a value of 0 to 15.

For PSS you can specify a value of 0 to 7 depending on circuit type:

PVC	0,1
SVC (IN)	2,3
SVC (I/O)	4,5
SVC (OUT)	6,7

TYPE= { PVC
ISVC
OSVC
IOSVC }

Specifies the composition of a logical channel group.

Table 2-29. Applicability of VCGROUP Macroinstruction and Its Operands

Macro: VCGROUP	ICAM Network Type and Kind of Program Supported										
	Direct Data Interface		Dedicated Networks			Global Networks					
Operand Name	DDI	RBP	TCI (IMS)	STDMCP	CMCS (COBOL)	STDMCP	TCI (IMS)	COBOL	DMI	DCA	†Public Data Networks
	NTR										
	RPG										
	IDES										
*VCGROUP	-	-	-	-	-	-	-	-	-	-	O
label	-	-	-	-	-	-	-	-	-	-	R
LCGN=	-	-	-	-	-	-	-	-	-	-	R
TYPE=	-	-	-	-	-	-	-	-	-	-	R
NUMBER=	-	-	-	-	-	-	-	-	-	-	R

*Shows macro applicability

†DDX and PSS only

LEGEND:

R = Required O = Optional - = Not applicable

PVC

Specifies this logical channel group is composed of permanent virtual circuits only.

ISVC

Specifies this logical channel group is composed of incoming switched virtual circuits only.

OSVC

Specifies this logical channel group is composed of outgoing switched virtual circuits only.

IOSVC

Specifies this logical channel group is composed of switched virtual circuits that can handle both incoming and outgoing calls.

NUMBER=n

Specifies the number of virtual circuits in this logical channel group. Never specify zero. Valid values are 1-255.

2.28. How to Specify Virtual Channels (VLINE)

The VLINE macro specifies the physical link that connects two computer nodes in a global network system. In a PDN environment it defines the physical line that connects the data terminal equipment (DTE) and the data terminal communications equipment (DCE).

VLINE is used with DCA multinode, Telcon or UNIX file transfer, or public data networks. It is not used in dedicated network definitions or global network definitions where the end users reside in the same computer node.

Note: You must specify all resources that pertain to a particular VLINE before you define any additional VLINEs.

Table 2-30 describes the interface and type of network definition in which you may use this macro. It also details the applicability of each operand in the macro. The first line in the table is the name of the macro itself preceded by an asterisk (to distinguish it from its operands).

Format

LABEL	ΔOPERATIONΔ	OPERAND
symbol	VLINE	ID=slca-number ,DEVICE= { ABM LAPA LAPB (NRM) } [,CHAN=channel-number] [,K= { value } { 7 }] [,RETRY= { (n,m) } { 10,10 }] [,TIMEOUT= { (n,m) } { 4,20 }] [,LBUF= { (number, size, threshold) } { 19,64,1 }] [,TYPE= { (line-speed) , { X21 } , { SWCH } , UNAT } { 9600 } , { RS232C } , { LEASED }] [,CMDADDR= { 1 } { n }] [,RSPADDR= { 3 } { n }]

Table 2-30. Applicability of VLINE Macroinstruction and Its Operands

Macro: VLINE	ICAM Network Type and Kind of Program Supported										
	Direct Data Interface		Dedicated Networks			Global Networks					
Operand Name	DDI	RBP	TCI (IMS)	STDMCP	CMCS (COBOL)	STDMCP	TCI (IMS)	COBOL	DMI	DCA	Public Data Networks
	NTR										
*VLINE	-	-	-	-	-	-	-	-	-	O	R
label	-	-	-	-	-	-	-	-	-	R	R
ID=	-	-	-	-	-	-	-	-	-	O	O
CHAN=	-	-	-	-	-	-	-	-	-	O	O
CMDADDR=	-	-	-	-	-	-	-	-	-	O	O
DEVICE=	-	-	-	-	-	-	-	-	-	R	R
K=	-	-	-	-	-	-	-	-	-	O	O
LBUF=	-	-	-	-	-	-	-	-	-	O	O
RETRY=	-	-	-	-	-	-	-	-	-	O	O
RSPADDR=	-	-	-	-	-	-	-	-	-	O	O
TIMEOUT=	-	-	-	-	-	-	-	-	-	O	O
TYPE=	-	-	-	-	-	-	-	-	-	O	R

*Shows macro applicability

LEGEND:

R = Required O = Optional - = Not applicable

Label

symbol

Is a 1- to 4-character required name of this physical link. It is also referenced by the LPORT macro.

Operands

ID=*slca-number*

For System 80 models 3 through 6, the *slca-number* is specified as a number from 8 to 15 identifying the line number of the single line communications adapter (SLCA).

For System 80 models 8 through 20, the *slca-number* can be from 1 to 15 for each input/output microprocessor (IOMP).

DEVICE= {
 ABM
 LAPA
 LAPB
 (NRM)

Specifies the type of protocol used on this physical link.

ABM

Specifies this line is used for communications between two OS/3 DCA termination systems in a distributed communications architecture data processing environment. This operand must be specified for circuit-switched PDNs.

LAPA

Specifies CCITT recommendation X.25 link access procedure A (LAPA) protocol is used on this line. This operand can only be used with the DATAPAC packet-switched public data network.

LAPB

Specifies CCITT recommendation X.25 link access procedure B (LAPB) protocol is used on this line, and this line is used with a DATAPAC, DATEX, DDX, IBERPAC, PSS, or TRANSPAC packet-switched PDN.

(NRM)

Specifies that the UDLC/NRM protocol is used. For the UNIX O/S file transfer capability, you must specify DEVICE=(NRM).

CHAN=*channel-number*

Specifies the input/output microprocessor (IOMP) to which the single-line communications adapter (SLCA) is connected.

For System 80 models 3 through 6, this operand is optional. If specified, the only value permitted is CHAN=2. The default is CHAN=2. Up to eight SLCAs (ID=8 to ID=15) can be specified for these models.

For System 80 models 8 through 20 with one IOMP, this operand is optional. If specified, the only value permitted is CHAN=13. The default is CHAN=13. Up to 14 SLCAs (ID=1 to ID=15) can be specified for the IOMP.

For System 80 models 8 through 20 with two IOMPs, this operand is optional. If specified, you must also specify the ID= operand. The only values permitted are CHAN=13 and CHAN=15. Up to 14 SLCA's (ID=1 to ID=15) can be specified for each IOMP.

K=value

Specifies the number of frames (K window value) that can be sent or received across this virtual link before an acknowledgment is required. You can specify a value of 1 to 7 subject to the following guidelines:

- If you specify DEVICE=ABM, you must specify K=1.
- If you specify DEVICE=LAPA or DEVICE=LAPB, specify K=7.
- If you specify DEVICE=NRM, do not specify a value for K.

RETRY=(n,m)

Specifies the number of retries that the remote device handler is to attempt before an error message is sent to the operator.

n

Is a decimal value, from 1 to 255, that specifies the maximum number of times a command or data message is sent due to the lack of an acknowledgment. If an output message is not acknowledged, the remote device handler waits the time specified in the TIMEOUT operand and retransmits the message. This sequence of timing-out and retransmission continues until the value specified in this operand is satisfied; at this time, an error message is sent to the operator.

m

Is a decimal value, from 1 to 255, that specifies the number of attempts the remote device handler makes to write a command, data, or response due to a hardware failure or a time-out. The remote device handler receives a report of whether the message was sent; if not, it retransmits the message until the value specified in m is reached. At this time, a message is sent to the computer operator.

If you omit this operand, RETRY=(10,10) is assumed.

TIMEOUT=(n,m)

Specifies the time-out period the ICAM remote device handler is to wait for a response to an output message and the maximum time it is to allow for a line buffer to empty or terminate.

n

Is the maximum time in seconds (1 to 32000) that the ICAM remote device handler is to wait for an acknowledgment before retransmitting the data message or command. (See RETRY.)

m

Is the maximum time in seconds (1 to 32000) to empty or terminate a line buffer.

If this operand is not specified, it defaults to: TIMEOUT=(4,20).

LBUF=(number, size, threshold)

Generates a buffer pool associated with this physical link. The operand defines the number of buffers created, the size of each buffer, and a threshold value.

Note: Do not specify this operand if you specified DEVICE=(ABM, ...) or DEVICE=(NRM).

number

Is a decimal value that specifies how many buffers are created. You must specify at least 19 buffers.

size

Is the maximum number of words (4-byte words) of data that can be transferred across the virtual line within one information frame. ICAM breaks up user messages into segments that fit into the buffer size specified and places them into the buffers before transferring the data. The actual size of a buffer is the size specified, plus line protocol framing characters.

threshold

Is a decimal number of inactive VLINE buffers that you will allow. When this minimum is reached, ICAM ceases solicitation of further input until a safe level is reached. It is suggested that you specify a value 10 to 15 per cent of the numbers you specify for number.

If you do not specify the LBUF operand, it defaults as LBUF=(19,64,1).

TYPE=(({line-speed} , {X21} , {SWCH} [,UNAT])
 {9600} {RS232C} {LEASED})

line-speed

Specifies the rate (Baud) at which data is transferred between two computers described in this macro. Line speed is a function of the modems used. Acceptable values are: 2400, 4800, 9600, 19200, 48000, and 56000. For PDNs, acceptable values are 2400, 4800, and 9600 (packet-switched); 600, 2400, 4800, and 9600 (circuit-switched). For an NRM dedicated line, the value must not exceed 4800.

X21

Specifies a CCITT X.21 interface between the data terminal equipment (DTE) and the data circuit terminating equipment (DCE). This operand must be specified for all circuit-switched networks and for DATEX-P networks using X.21 leased lines.

RS232C

Specifies an EIA RS-232-C interface between the data terminal equipment (DTE) and the data circuit terminating equipment (DCE). This operand is valid for packet-switched networks only.

SVCH

Specifies that the line must be dialed by the operator.

LEASED

Specifies this virtual line is leased; i.e., a private line. This operand must be specified for packet-switched PDNs.

UNAT

Specifies this line is in unattended answering mode of operation.

CMDADDR= $\left\{ \begin{array}{c} 1 \\ n \end{array} \right\}$

Is a decimal number from 1 to 255 specifying the universal data link control frame level address used to transmit commands and receive responses. The default value is 1.

RSPADDR= $\left\{ \begin{array}{c} 3 \\ n \end{array} \right\}$

Is a decimal number from 1 to 255 specifying the universal data link control frame level address used to transmit responses and receive commands. The default value is 3.

Notes:

1. *CMDADDR and RSPADDR are needed only when DEVICE=ABM is specified.*
2. *When running multinode, the CMDADDR value of A must equal the RSPADDR value of B, and the RSPADDR value of A must equal the CMDADDR value of B.*
3. *When running Telcon, the CMDADDR value must equal the LSA value in the STATION statement in the Telcon generation, and the RSPADDR value must equal the RSA value.*

Section 3

Defining Your Network

3.1. How to Prepare Your Network Definition

Before you write an ICAM network definition, be sure to understand the overall structure of your computer's communications network. Also, you must be able to define:

- ICAM end users (such as terminals, LOCAP files, and process files)
- Session paths between end users, including lines and ports
- ICAM interfaces (such as STDMCP, TCI, and DMI)
- ICAM network types (dedicated or global)

All of the available network types are discussed in this section, with sample network definitions covering many applications. Table 3-1 lists the macros described in Section 2 and indicates each applicable type of network definition. Table 3-2 highlights the important macros and operands for each type of network definition. These tables will help you prepare your own network definitions.

Defining Your Network

Table 3-1. Macroinstruction Usage by Network Definition Type

Macro Name	Dedicated Networks			Global Networks						Main Use	
	DDI*	TCI (IMS)	STDMCP**					Public Data Networks			
				STDMCP**	TCI (IMS)	DMI	DCA	Circuit-Switched	Packet-Switched		
BUFFERS	R	R	R	R	R	R	R	R	R	R	Establishes network and activity request packet pools
CCA	R	R	R	R	R	R	R	R	R	R	Identifies the beginning of a network, ICAM features, journaling requirements, etc.
CGRPEND	-	-	-	-	-	-	O	-	-	-	Indicates the end of a UDLC/NRM configuration group definition
CONGRP	-	-	-	-	-	-	O	-	-	-	Defines a group of stations connected to a particular line (VLINE) when using NRM line control
CPSTB	-	-	-	-	-	-	-	O	-	-	Indicates status of a circuit-switched public data network
DPCPNL	-	-	-	O	O	O	O	O	O	O	Specifies DCP channel characteristics
DISCFILE Buffering	-	R	-	-	-	-	-	-	-	-	Defines a disk file for message buffering by ICAM
DISCFILE Queuing	-	O	O	O	O	-	O	O	O	O	Defines a disk file for message queuing by ICAM
DISCFILE	-	R	O	O	O	-	O	O	O	O	Defines a disk file for use by ICAM
DLIST	-	O	O (R)	O (R)	O	-	O	O	O	O	Creates a list of destinations in your network
ENDCCA	R	R	R	R	R	R	R	R	R	R	Indicates the end of a network definition
EUP	-	O	O	O (-)	O	O	-	-	-	-	Formats output messages to terminals
JRNFILE	-	O	O	O	O	-	-	-	-	O	Defines a journal file
LDTE	-	-	-	-	-	-	-	R	-	-	Defines attributes of a local data terminal equipment in a circuit-switched public data network
LINE	R	R	R	R	R	R	O	O	O	O	Establishes the characteristics of each line in a communications network
LOCAP	-	-	-	R	R	R	O	O	O	O	Creates a locap file for user programs that use global networks

continued

Table 3-1. Macroinstruction Usage by Network Definition Type (cont.)

Macro Name	Dedicated Networks			Global Networks						Main Use	
	DDI*	TCI (IMS)	STDMCP**					Public Data Networks			
				STDMCP**	TCI (IMS)	DMI	DCA	Circuit-Switched	Packet-Switched		
LPORT	-	-	-	-	-	-	-	O	R	-	Defines a logical port for distributed communications architecture (DCA)
PDN	-	-	-	-	-	-	-	-	R	R	Defines a circuit-switched or packet-switched public data network
PGROUP	-	-	-	O (-)	O	O	O	O	-	-	Specifies a poll group for remote workstations
PRCS	-	O	O (R)	O (R)	O	-	O	O	O	O	Defines a process file for temporary storage of messages
PVC	-	-	-	-	-	-	-	-	-	O	Defines a permanent virtual circuit on a packet-switched public data network
RDTE	-	-	-	-	-	-	-	-	R	-	Defines attributes of a remote data terminal equipment in a circuit-switched public data network
SESSION	-	-	-	O	O	-	-	O	O	O	Defines a static session in a global network
STATION	-	-	-	-	-	-	-	O	-	-	Defines the unique characteristics of a station (required by the NRM link level control)
SUB	-	-	-	-	-	-	-	-	-	R	Defines a remote subscriber on a packet-switched public data network
TERM	R	R	R	R	R	R	R	O	O	O	Defines the characteristics of each terminal
TRUNK	-	-	-	-	-	-	-	-	-	R	Defines a trunk on a packet-switched public data network
VCGROUP	-	-	-	-	-	-	-	-	-	O	Defines a virtual circuit group on a packet-switched public data network
VLINE	-	-	-	-	-	-	-	O	R	R	Defines the physical link between two computer nodes in a multinode global network

* Includes NTR and RBP network definitions.
 ** Legend in parentheses is for COBOL (CMCS) applications.

LEGEND:

- R = Required
- O = Optional
- = Not applicable

Defining Your Network

Table 3-2. OS/3 Basic Network Configurations

Dedicated	Standard	IMS	DDI	RBP	NTR
CCA TYPE=	(STDMCP)	(TCI)	(DDI)	(RBP1) (RBP2)	(NTR)

Single-Node Global	Standard	IMS	IS/DDP
CCA TYPE=	(GBL,,node)	(GBL,,node)	(GBL,,node)
LOCAP TYPE= IAS=	(STDMCP)	(TCI)	(DMI) YES

Multinode Global	DCA			DCA PDN ^②	
	Standard Dynamic Sessions	IS/DDP Dynamic Sessions	IMS Dynamic Sessions	Circuit-Switched	Packet-Switched
CCA TYPE= DCA= GAWAKE=	(GBL,,node) YES YES	(GBL,,node) YES YES	(GBL,,node) YES YES	(GBL,,node) YES YES	(GBL,,node) YES
LINE DEVICE= ①					
TERM FEATURES= ① PROTYP= RBATCH= DVCGID= REMOTE=	INT-1/RB-2/DEV node-id	INT-1/RB-2/DEV node-id	INT-1/RB-2/DEV node-id		subname, PDN
LOCAP TYPE= PROTYP= IAS=	(STDMCP) DICE	(DMI) XPARENT ^① (YES, OFF)	(TCI) DICE	(DMI)/(STDMCP)/ (TCI) XPARENT	(DMI)/(STDMCP)/ (TCI) XPARENT
PDN CARRIER= TYPE=				carrier-name CIRCUIT	carrier-name PACKET
VLINE DEVICE=	ABM	{ ABM NRM }	ABM	ABM	LAPB
LPORT USERTP=	STDMCP	DMI	TCI	STDMCP	

continued

Table 3-2. OS/3 Basic Network Configurations (cont.)

NOTES

- ① The DEVICE operand of the LINE macroinstruction and the FEATURES operand of the TERM macroinstruction define the protocol and device handlers to be incorporated for the specific terminals or workstations attached to each line.

To use a local workstation with a user program, include the following operands

```

LINE    DEVICE=(LWS)
TERM    FEATURES=(U20),ADDR=(dev-addr)
        or
        (U40)

```

To use an interactive terminal with interactive services, include the following operands (this lets an interactive terminal emulate a workstation):

```

LOCAP   TYPE=(DMI),IAS=(YES,OFF)
LINE    DEVICE=(UNISCOPE)
TERM    FEATURES=(...),TCTUPD=YES

```

To use a remote workstation with a user program, include the following operands:

```

LOCAP   TYPE=(STDMCP) or (TCI)
LOCAP   TYPE=(DMI),MODE=SYSTEM,IAS=(YES,OFF)
LINE    DEVICE=(RWS)
PGROUP  PGID=rid
TERM    FEATURES=(U40)...
TERM    FEATURES=(U40)...

```

The non-DMI locap file is for workstation mode; the DMI locap file is for interactive services.

Remote workstations are grouped in poll groups. A PGROUP macroinstruction must precede each group of workstations in a poll group.

Remote workstations with dual screen capability requires a TERM macroinstruction for each of the two screens. The FEATURES operand of the first TERM macroinstruction must specify the primary screen; and the other TERM macroinstruction specifies the secondary screen.

When using interactive terminals in a DCA/DCP environment the TERM macroinstruction must specify PROTYP=INT-1. For terminals attached to a remote OS/3 system, the default for the PROTYP operand must be used. If you are using DDP, you must also specify PROTYP=XPARENT on the LOCAP macroinstruction.

When you use remote batch terminals in a DCA/DCP environment, the TERM macroinstruction must include PROTYP=RB-2,RBATCH=YES,XLATE(NO,NO). For terminals connected to a remote OS/3 system, the default for the PROTYP operand must be used.

- ② Macroinstructions that apply to circuit-switched and packet-switched public data networks (PDNs) are not shown for simplicity sake. A DATEX-L circuit-switched PDN is a special case that can be defined in a dedicated or single-node global network with operands on the LINE and TERM macroinstructions. (A virtual line is not used for DATEX-L.)

3.2. Dedicated Network Definitions

In a dedicated network, lines and terminals are dedicated (assigned) to one program only. They cannot be reassigned to another program until the network is released.

You can have more than one program executing at the same time, but you must define independent networks for each program.

Dedicated networks are simpler to define than the global networks described later in this section, but they are limited because:

- Programs cannot share lines and terminals.
- Your communications system cannot support more than one central processor.

3.2.1. Direct Data Interface Network Definition

The direct data interface (DDI) network definition uses a limited set of network definition macros as shown in Table 3-1. The DDI does not support message queuing, process files, network buffering, distribution lists, disk buffering, MPPS, journaling, global networking, or message formatting.

The suggested order of presentation of macros is shown in Table 3-3. You can generate several networks in the same ICAM symbiont, and all of the networks need not be DDI networks.

Figure 3-1 shows a typical direct data interface network with two communications lines. Line 1 is a switched line with two UNISCOPE 100 display terminals. Line 2 is a dedicated line, and it connects a 1004 card processing system. The lines are synchronous and operate in two-way alternate mode at a transmission rate of 2000 baud. The card processor provides a remote site identifier of PSDC, and the phone numbers are 123-4567 and 123-4568 respectively. (The hyphen creates a short delay in dialing if you need it.)

Figure 3-2 shows the network definition for the network in Figure 3-1. Note the simplicity of the coding. This is because DDI does not support most of the ICAM features supported by standard interface, dedicated, and global networks. The macros that are supported are indicated in Table 3-1. Where there are differences between support for this type of network and the other types of networks for a given macro, the differences are described in the macro descriptions in Section 2.

In the CCA macro, you must specify the level of ICAM support you require (TYPE=(DDI,level)). Full support is level 3, and it is the only level that supports batch mode operation.

Table 3-3. Order of Presentation of Macroinstructions in a Direct Data Interface (DDI) Network Definition

Macroinstruction Name	Remarks
CCA ₁	Identifies the beginning of an ICAM DDI network definition
BUFFERS	Creates an activity request packet pool and a network buffer pool if datagrams are required
LINE ₁	Identifies the characteristics of the first line
TERM ₁	Defines the characteristics of the first terminal on this line
.	
TERM _n	Defines the characteristics of the last terminal on this line
LINE _n	Identifies the characteristics of the last line
TERM ₁	
.	
TERM _n	
ENDCCA ₁	Ends this network definition
CCA _n	} Identifies the start and end of the last network definition
.	
ENDCCA _n	

UNISCOPE lines supporting more than one terminal with auxiliary devices on at least one line must use level 2 or 3 to take advantage of multiple-output message control table (MCT) (one per terminal) handling. DDI level 2 (DDI,2) is the same as level 3, less batch support. DDI level 1 (DDI,1) is a minimum-support DDI for users with limited requirements and limited main storage. It does not support EOM condition code, auxiliary devices, multiple UNISCOPE output MCTs, or wait logic for EOM in last input buffers.

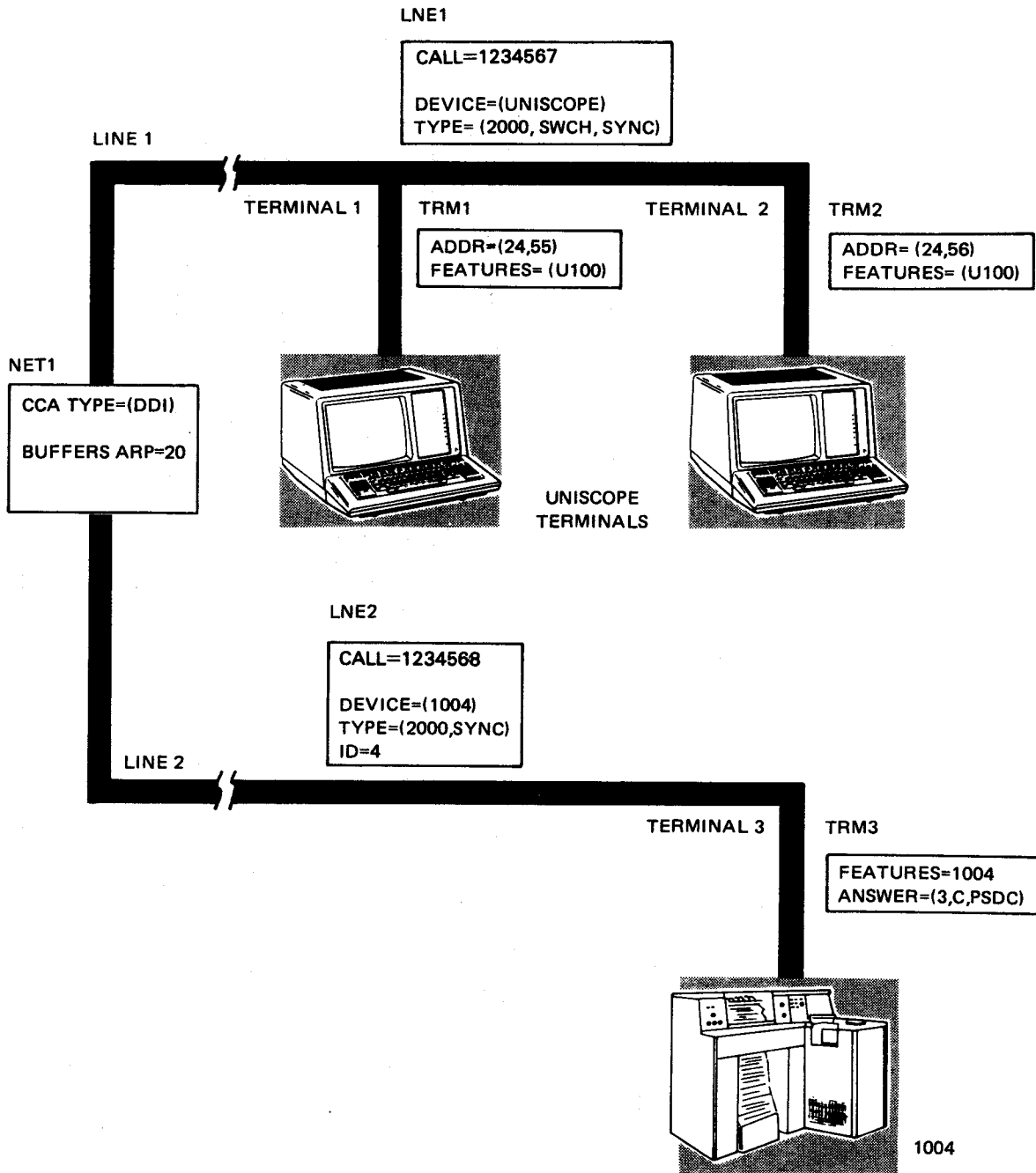

Figure 3-1. Direct Data Interface (DDI) Network

```

1 _____ 72
NET1  CCA  TYPE=(DDI,3)
      BUFFERS ARP=20
LNE1  LINE CALL=123-4567,           X
      DEVICE=(UNISCOPE),          X
      TYPE=(2000,SWCH,SYNC)
TRM1  TERM FEATURES=(U100),        X
      ADDR=(24,55)
TRM2  TERM FEATURES=(U100,1024),   X
      ADDR=(24,56)
LNE2  LINE CALL=123-4568,           X
      DEVICE=(1004),              X
      TYPE=(2000,SYNC),           X
      ID=4
TRM3  TERM FEATURES=(1004),        X
      ANSWER=(4,C,PSDC)
      ENDCCA

```

Figure 3-2. Coding for a Direct Data Interface (DDI) Network Definition

3.2.2. Standard Interface Dedicated Network Definition

The standard interface (STDMCP) dedicated network provides a complete, logical, queued communications facility. This interface enables communications between a group of terminals you define as a communications network and one of your programs. When one of your programs activates a standard interface dedicated network, the terminals, process files, etc, that are identified in that network are available only to that program. The resources are held until your program releases the network, thereby making them available to another one of your programs.

You may define several dedicated networks in one ICAM symbiont, and activate one at a time with the same program, or you can activate all of them by means of several of your programs. (Refer to *ICAM Concepts and Facilities* (UP-8194) for more information.)

You should use the facilities available through standard interface global networks if you are writing a program that needs to do any of the following:

- Send and receive messages to or from any terminal in your total communications environment
- Communicate between your programs in the same computer or between computers
- Make available to any of your programs messages input from any of the terminals in the system
- Run several of your communications programs concurrently using the same network

Table 3-4 shows the recommended order of presentation of macros for a STDMCP dedicated network definition.

Table 3-4. Order of Presentation for Macroinstructions in a Standard Interface and Transaction Control Interface Dedicated Network Definition

Macro	Remarks
CCA ₁	Identifies the beginning of a network definition
BUFFERS	Generates required system resources
LINE ₁	Defines the characteristics of the first line
...	
TERM ₁	Specifies the characteristics of the first terminal on this line
...	
TERM _n	Specifies the characteristics of the last terminal on this line
...	
LINE _n	Specifies the characteristics of the last line in the system
TERM ₁	Specifies the terminal definitions for the last line in this network
EUP ₁	Specifies optional end user profile for message format editing, if used
...	
TERM _n	
EUP _n	
DISCFIL ₁	Specifies the first disk file used with this network
...	
DISCFIL _n	Specifies the last disk file used
JRNFILE ₁	Specifies the first journal file for this network
...	
JRNFILE _n	Specifies the last journal file for this network
DLIST ₁	Specifies one or more distribution lists for this network definition
...	
DLIST _n	

continued

Table 3-4. Order of Presentation for Macroinstructions in a Standard Interface and Transaction Control Interface Dedicated Network Definition (cont.)

Macro	Remarks
PRCS ₁	Specifies the first process file for this network
PRCS _n	Specifies the last process file used in this network
MPSTART ₁	Specifies the beginning of the first optional message processing routine (MPPS)*
MPPS macros	Message processing routine macroinstructions
MPSTART _n	Specifies the beginning of the last optional message processing routine
MPPS macros	Message processing routine macroinstructions
ENDCCA ₁	Specifies the end of this network definition
CCA _n	Specifies the start of the last dedicated network definition
ENDCCA _n	Specifies the end of the last dedicated network definition

* Message processing procedure specification (MPPS) routines are described in the *ICAM Programming Reference Manual* (UP-9749).

Basic Standard Interface Dedicated Network Definition

Figure 3-3 shows an example of a basic standard interface dedicated network using two communications lines. One communications line is a manually dialed (switched) line with a single DCT 500 terminal connected to it. The DCT 500 terminal operates in automatic mode. The other line is a dedicated line having two UTS 400 terminals attached.

Figure 3-4 shows the coding for this network definition. Each line of coding is annotated as to its meaning. In addition, parts of the coding are shown in Figure 3-3 to further simplify the example.

Defining Your Network

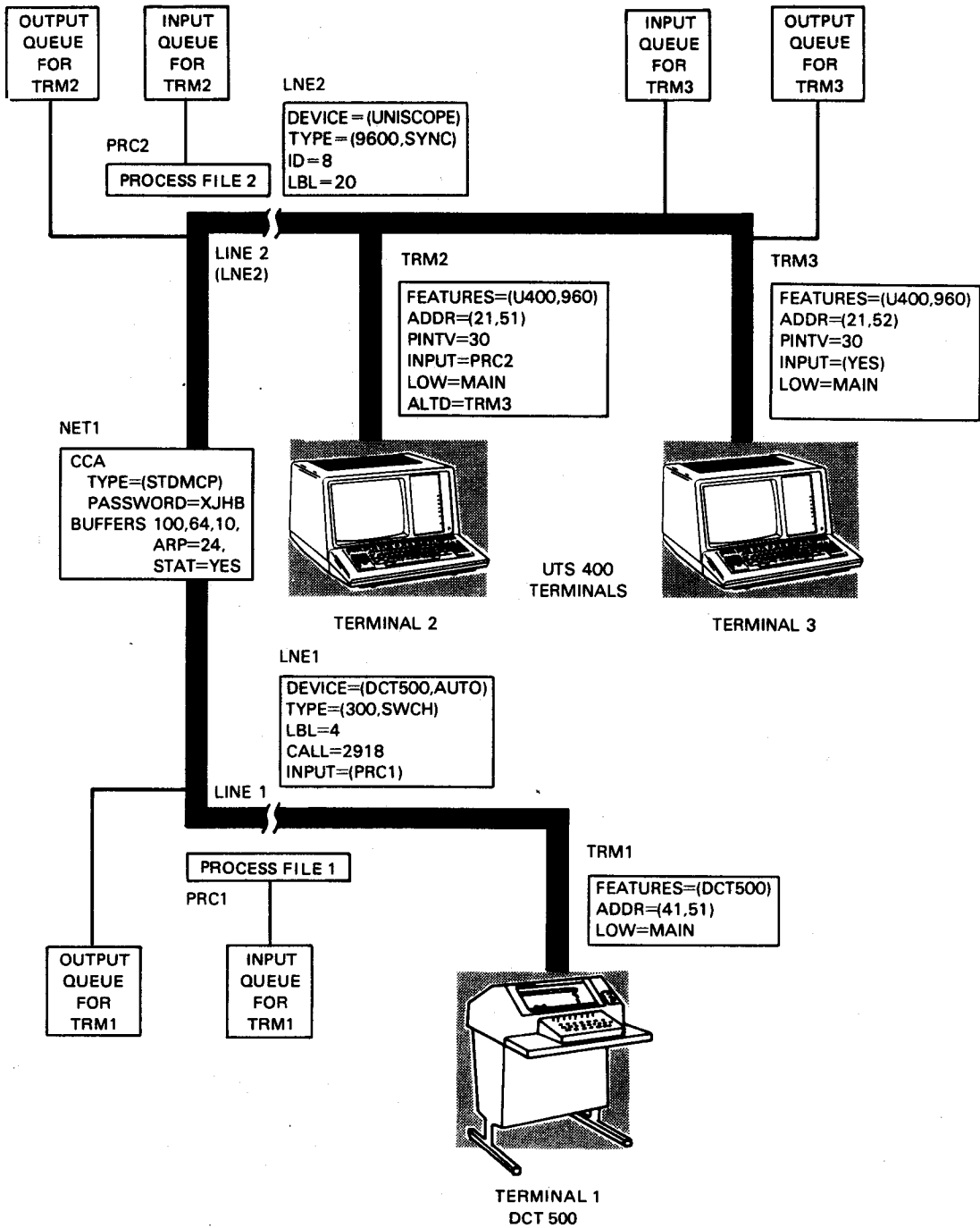

Figure 3-3. Standard Interface Dedicated Network with No Auxiliary Devices

1	72
1. NET1 CCA TYPE=(STDMCP),PASSWORD=XJHB, CCAID=JHBNET,FEATURES=(OPCOM)	X
2. BUFFERS 100,64,10,ARP=24,STAT=YES	
3. LNE1 LINE DEVICE=(DCT500,AUTO),TYPE=(300,SWCH), LBL=4,CALL=2918,INPUT=(PRC1)	X
4. TRM1 TERM FEATURES=(DCT500),ADDR=(41,51),LOW=MAIN	
5. LNE2 LINE DEVICE=(UNISCOPE),TYPE=(9600,SYNC),ID=8,LBL=20	
6. TRM2 TERM FEATURES=(U400,960),ADDR=(21,51),PINTV=30, INPUT=(PRC2),LOW=MAIN,ALTD=TRM3	X
7. TRM3 TERM FEATURES=(U400,960),ADDR=(21,52),PINTV=30, INPUT=(YES),LOW=MAIN	X
8. PRC1 PRCS LOW=MAIN	
9. PRC2 PRCS LOW=MAIN	
10. ENDCCA	

NOTES:

1. STDMCP indicates this is the beginning of a network definition for a standard interface dedicated network named NET1. A password (XJHB) is defined, JHBNET is to be placed at the top of each listing page, and operator communications are required.
2. A network buffer pool of 100 64-word network buffers is established with a threshold of 10. There are 24 activity request packets specified along with counters to accumulate statistics on the use of the network buffer and activity request packet pools.
3. Line 1 is defined. It supports DCT 500 terminals in automatic mode at 300 baud on a switched (dialed) line. The line buffer length is 4 words, the terminal phone number is 2918, and input from this line is directed to process file PRC1 unless overridden by an INPUT operand in the TERM macroinstruction.
4. This line defines the DCT 500 terminal. The device address is 41,51 and an output queue is established for it by means of the LOW=MAIN operand. The input from this terminal is directed to PRC1.
5. The second line is defined. It supports UTS 400 terminals by means of the UNISCOPE remote device handler on a 9600 baud synchronous line. The SLCA ID is 8, and the line buffer length is 20 words.
6. The first UTS 400 terminal is defined. It has a screen size of 960 characters, its rid, sid address is 21,51, it is polled every 3 seconds, and its input is placed on process file PRC2. A main storage output queue is established and an alternate destination is established (terminal 3).
7. This line defines the second UTS 400 terminal on line LNE2. Its definition is almost the same as for the first terminal, except that all of its input is placed on a special input queue for terminal TRM3 (INPUT=YES).
8. Defines a process file (PRC1).
9. Defines a process file (PRC2).
10. This line indicates the end of this network definition.

Figure 3-4. Coding for a Standard Interface Dedicated Network with No Auxiliary Devices

Standard Interface Dedicated Network Definition Using a Message Processing Routine

Figure 3-5 shows a standard interface dedicated network used with UNISCOPE terminals, TELETYPE teletypewriter Model 33 terminals, and a 1004 system. In addition, two message processing routines are used. Message processing routines are described in the *ICAM Programming Reference Manual (UP-9749)*. This example shows how to include message processing routines in a network definition with disk files. Figure 3-6 is the same network coded into a network definition. Notice that the INPUT operands in the LINE and TERM macros reference the message processing routine that handles input and output for that line or terminal.

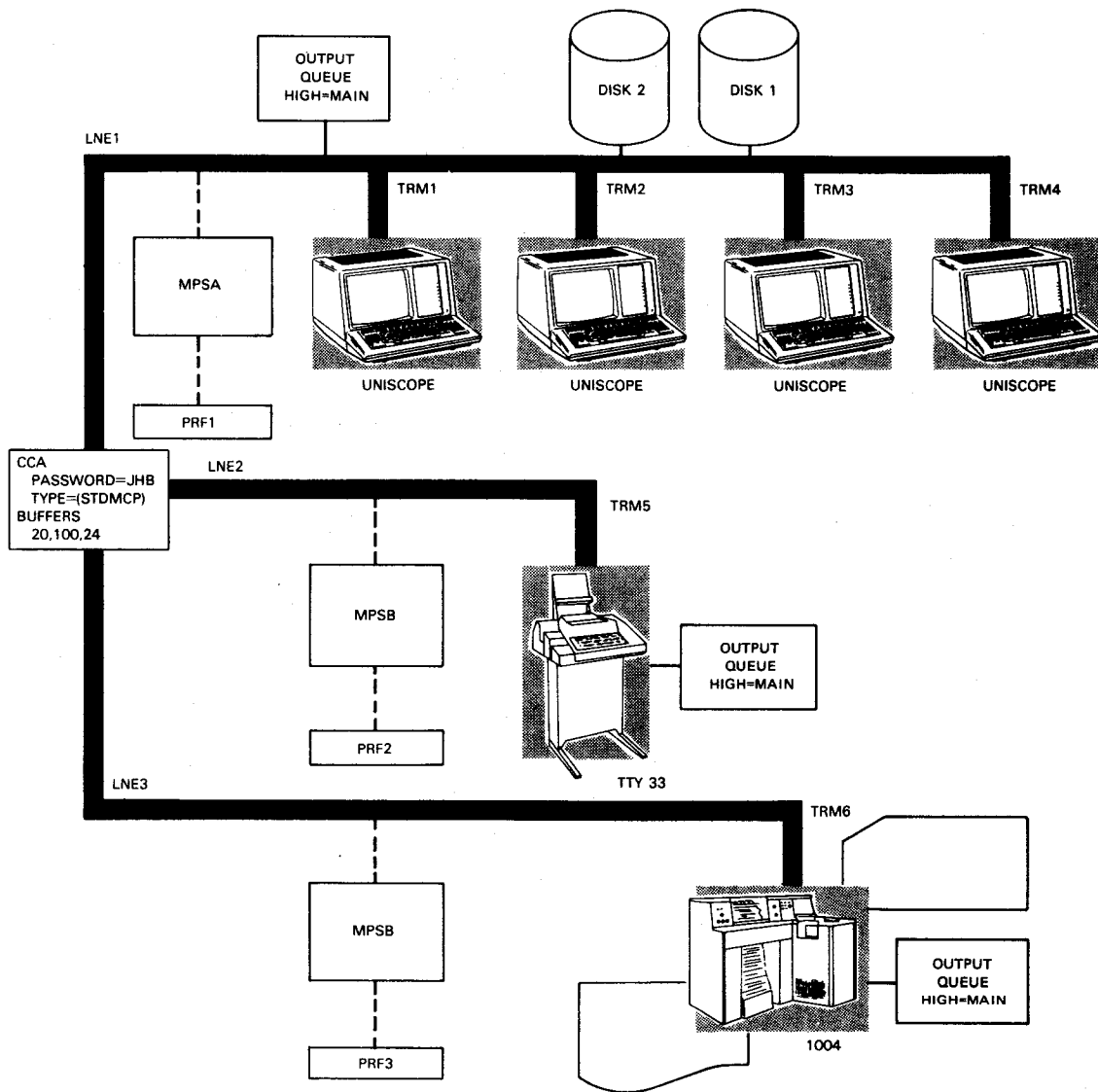

Figure 3-5. Standard Interface Dedicated Network Using a Message Processing Routine

1		72	
NET1	CCA	PASSWORD=JHB, TYPE=(STDMCP)	X
		BUFFERS 20,100,,ARP=24	
LNE1	LINE	CALL=6461062,	X
		DEVICE=(UNISCOPE),	X
		TYPE=(2000,SWCH,SYNC),	X
		INPUT=(MPSA,6),	X
		HIGH=MAIN,MEDIUM=DISC1,LOW=DISC2	
TRM1	TERM	ADDR=(29,53),	X
		FEATURES=(U100,1024),	X
		PINTV=50	
TRM2	TERM	ADDR=(29,54),	X
		FEATURES=(U100,1024),	X
		PINTV=50	
TRM3	TERM	ADDR=(28,51),	X
		FEATURES=(U100,1024),	X
		PINTV=50	
TRM4	TERM	ADDR=(28,52),	X
		FEATURES=(U100,1024),	X
		PINTV=50	
LNE2	LINE	CALL=6460262,	X
		DEVICE=(TTY,33),	X
		TYPE=(100,SWCH),	X
		INPUT=(MPSB,9)	
TRM5	TERM	FEATURES=(TTY),	X
		HIGH=MAIN	
LNE3	LINE	CALL=6462766,	X
		DEVICE=(1004),	X
		TYPE=(2400,UNAT,SWCH,SYNC),	X
		ID=8,	X
		INPUT=(MPSB,9)	
TRM6	TERM	ANSWER=(5,C,NYC01),	X
		FEATURES=(1004),	X
		HIGH=MAIN	
PRF1	PRCS	LOW=MAIN	
PRF2	PRCS	LOW=MAIN	
PRF3	PRCS	LOW=MAIN	
DISC1	DISCFILE	FILEDIV=10	
DISC2	DISCFILE	FILEDIV=10	
MPSA	MPSTART		
	RECHDR		
	DIRECT	P,PRF1,L	
	TIMSTP		
	RECEM		
	CANCELM	TN#MBINS	
	RECPST		
	SENHDR		
	SENEND		

Figure 3-6. Coding for the Standard Interface Dedicated Network Using a Message Processing Routine (Part 1 of 2)

```

1
72
RETRANS X'FFFF'
SENPST
MPSB MPSTART
RECHDR
MSGTYP 3,TTY,TYPE2
DIRECT P,PRF3,L
BRANCH REND
TYPE2 MSGTYP 4,1004,TYPE3
ADVANCE 4,DATE
DATSTP J
DIRECT P,PRF3
BRANCH REND
TYPE3 DIRECT SOURCE,,L
REND RECEND
RECPST
SENHDR
MSGTYP 4,1004,NOSEQOUT
SEQOUT 3
NOSEQOUT SENEND
REROUTO TN#MLERR,TRM1
SENPST
ENDCCA

```

Figure 3-6. Coding for the Standard Interface Dedicated Network Using a Message Processing Routine (Part 2 of 2)

Standard Interface Dedicated Network Definition with Auxiliary Devices

Figure 3-7 shows a communications network similar to the one shown in Figure 3-5, except that auxiliary devices have been added to the UTS 400 terminals. Two devices have been added to each terminal: one communications output printer (COP), and one tape cassette system (TCS). The auxiliary devices are specified with AUXn operands. Each AUX operand creates a displacement in an ICAM table, i.e., AUX1 refers to the first entry, and AUX4 refers to the fourth.

Your program uses these displacements to communicate with a particular auxiliary device. Some auxiliary devices, as shown in Figure 3-8, require four auxiliary device addresses (*dids*). Because of this, you have to be careful when you specify the AUX operand to allow for the extra device addresses. In the example, the COP of the TRM2 requires only one device address specified by AUX1. The TCS has two tape cassette drives, and each one of them requires two device addresses (usually, one for input and one for output). Therefore, AUX2 covers the second and third *dids*, and AUX4 covers the fourth and fifth. Remember that AUX3 is already used when you specify the second tape drive.

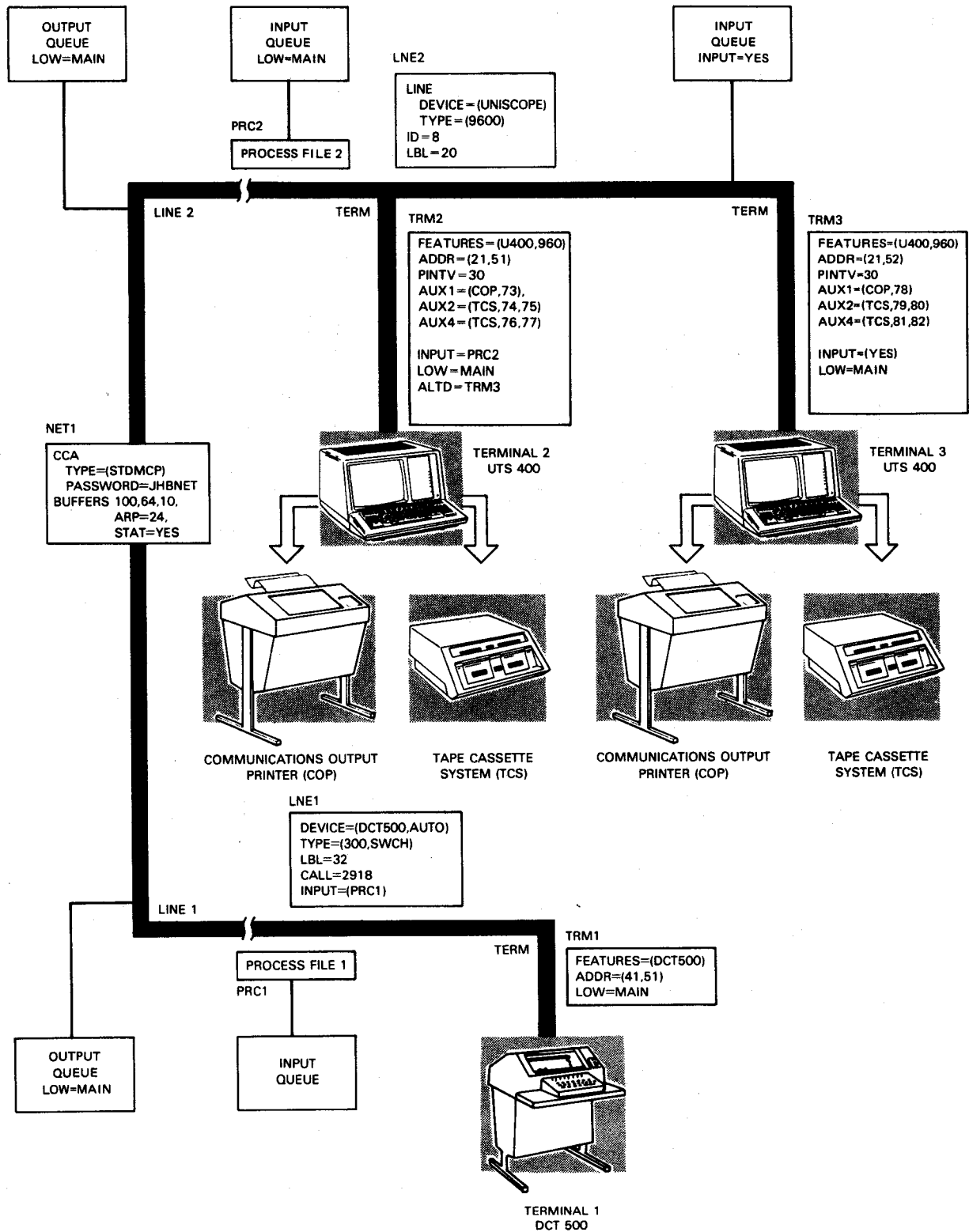

Figure 3-7. Standard Interface Dedicated Network with Auxiliary Devices

1	72	
NET1	CCA TYPE=(STDMCP),PASSWORD=JHBNET, CCAID=JHBNET,FEATURES=(OPCOM) BUFFERS 100,64,10,ARP=24,STAT=YES	X
LNE1	LINE DEVICE=(DCT500,AUTO),TYPE=(300,SWCH), LBL=32,CALL=2918,INPUT=(PRC1)	X
TRM1	TERM FEATURES=(DCT500),ADDR=(41,51),LOW=MAIN	
LNE2	LINE DEVICE=(UNISCOPE),TYPE=(9600,SYNC),ID=8,LBL=20	
TRM2	TERM FEATURES=(U400,960),ADDR=(21,51),PINTV=30, AUX1=(COP,73),AUX2=(TCS,74,75),AUX4=(TCS,76,77), INPUT=(PRC2),LOW=MAIN,ALTD=TRM3	X X
TRM3	TERM FEATURES=(U400,960),ADDR=(21,52),PINTV=30, AUX1=(COP,78),AUX2=(TCS,79,7A),AUX4=(TCS,7B,7C) INPUT=(YES),LOW=MAIN,	X X X
PRC1	PRCS LOW=MAIN	
PRC2	PRCS LOW=MAIN	
	ENDCCA	

Figure 3-8. Coding for a Standard Interface Dedicated Network with Auxiliary Devices

3.2.3. TCI Dedicated Network

The TCI network is available for the IMS user only. You code the dedicated TCI network definition like the dedicated STDMCP, except for the TYPE operand of the CCA macro - you must specify TYPE=(TCI).

TCI networks require disk buffering (not disk queuing) for input message handling. Therefore, use the INPUT operand in LINE and TERM macros to specify only a message processing routine. You may specify HIGH, MEDIUM, and LOW operands for output message queuing in the LINE or TERM macros. These queues may be on disk or in main storage. Disk buffering for output is not supported.

The transaction control interface network definition uses the macros provided in Section 2 of this user guide. Table 3-1 summarizes all of the macros that apply to this type of network definition. You create an ICAM symbiont by submitting your network definition to the system generation procedures described in Section 5, and the suggested order of presentation of macros is shown in Table 3-4. Note that you can generate several network definitions in the same ICAM symbiont at system generation, and that all of the networks need not be transaction control interface networks. For complete details on generating an ICAM network that supports IMS, see the *IMS System Support Functions Programming Guide* (UP-11907).

The transaction control interface network shown in Figure 3-9 is a 2-line system supporting multiple UNISCOPE terminals with attached auxiliary devices connected to one of the lines. Connected to a separate line is a DCT 500 terminal. Figure 3-10 shows how to code the network definition to support the network.

For additional network definition examples, see the *IMS System Support Functions Programming Guide (UP-11907)*.

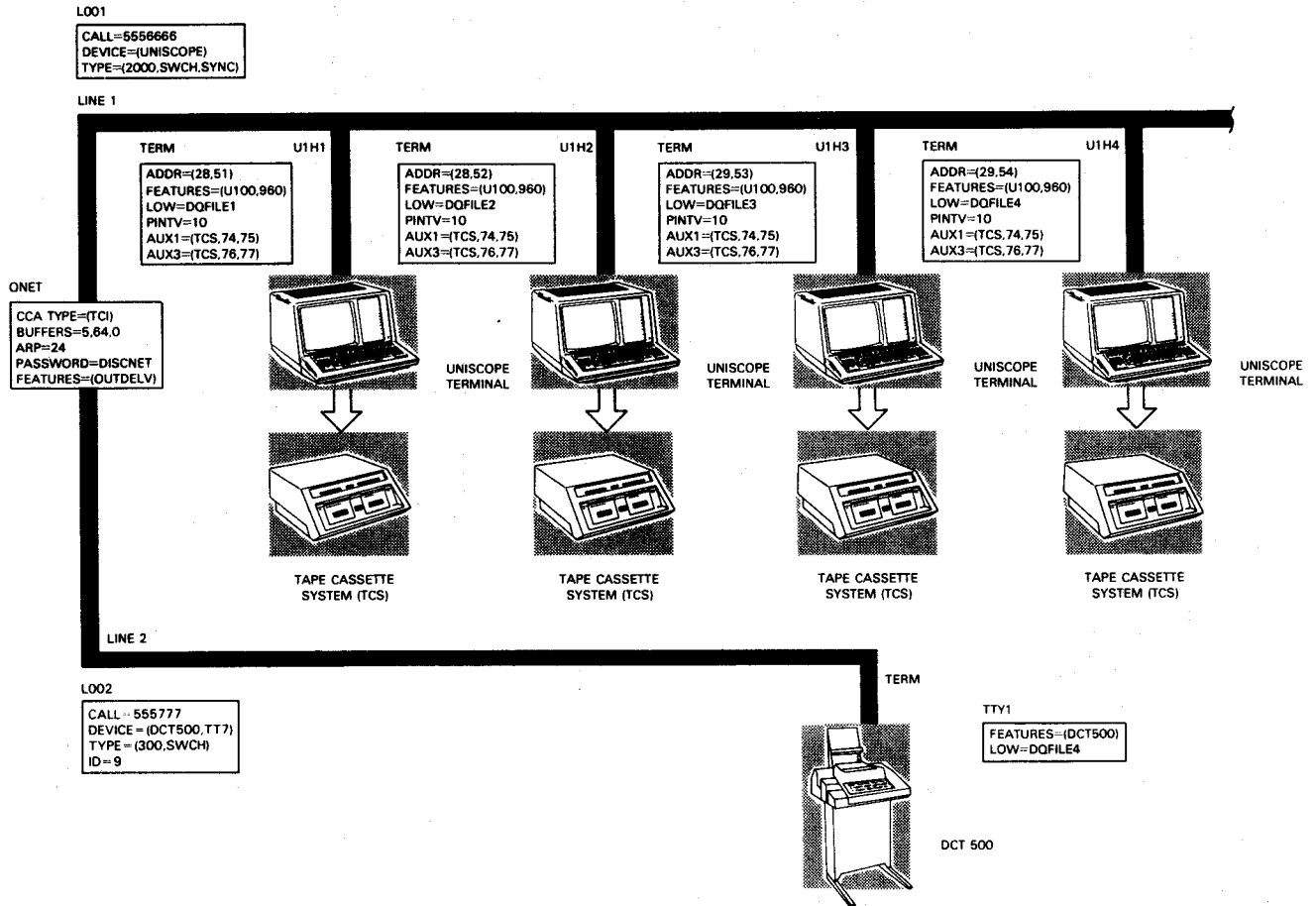

Figure 3-9. Disk Queued TCI Network with Auxiliary Devices

1	72
1.	<pre> ONET CCA TYPE=(TCI),PASSWORD=DISCNET,FEATURES=(OUTDELV) BUFFERS 5,64,0,ARP=24 </pre>
2.	<pre> L001 LINE DEVICE=(UNISCOPE),TYPE=(2400,SWCH,SYNC),CALL=5556666 U1H1 TERM ADDR=(28,51),FEATURES=(U100,960),PINTV=10, X LOW=DQFILE1, X </pre>
3.	<pre> AUX1=(TCS,74,75),AUX3=(TCS,76,77) U1H2 TERM ADDR=(28,52),FEATURES=(U100,960),PINTV=10, X LOW=DQFILE2,AUX1=(TCS,74,75), X AUX3=(TCS,76,77) </pre>
	<pre> U1H3 TERM ADDR=(29,53),FEATURES=(U100,960),PINTV=10, X LOW=DQFILE3, X AUX1=(TCS,74,75),AUX3=(TCS,76,77) </pre>
	<pre> U1H4 TERM ADDR=(29,54),FEATURES=(U100,960),PINTV=10, X LOW=DQFILE3,AUX1=(TCS,74,75), X AUX3=(TCS,76,77) </pre>
4.	<pre> L002 LINE DEVICE=(DCT500,TTY),TYPE=(300,SWCH),CALL=5557777,ID=9 TTY1 TERM FEATURES=(DCT500),LOW=DQFILE4 </pre>
5.	<pre> DQFILE1 DISCFILE FILEDIV=6 DQFILE2 DISCFILE FILEDIV=6 DQFILE3 DISCFILE FILEDIV=2 DQFILE4 DISCFILE FILEDIV=3 </pre>
6.	<pre> TCIDTF DISCFILE MSGSIZE=1024 ENDCCA </pre>

NOTES:

- The output delivery notification feature is specified.
- A synchronous, switched line. The line terminates four UNISCOPE 100 terminals, two with rid 28 and two with rid 29. Each UNISCOPE 100 terminal has a 960-character screen and a poll interval of 1 second. Line speed is 2400 baud.
- An auxiliary device tape cassette subsystem (TCS) is specified.
- An asynchronous, switched line with line speed of 300 baud on SLCA 9. The line terminates a DCT 500 in teletypewriter mode.
- Disk files are defined for disk queuing. Three files are used in line L001 and one file is used in line L002 for disk-queued output.
- A disk buffering file is defined for input.

Figure 3-10. Coding for the TCI Network with Auxiliary Devices and Disk Queuing

3.3. Global Network Configurations

In a global ICAM network, all user programs share network resources such as lines and terminals. Your program can communicate with any other end user in the network - terminal, process file, or LOCAP file.

You can create a global network to operate in a single computer (single-node global network) as shown in Figure 3-11, or you can create one to operate between two or more computers (multinode global network) as shown in Figure 3-12.

Within each computer node, all resources (terminals, process files, LOCAP files, and queues) are assigned to a supporting ICAM program known as the global user service task (GUST). GUST allocates resources between end users, as required by your programs, within the global network.

Since a global network does not exclusively belong to any one of your programs as in a dedicated network, your program can request attachment (connection) to the global network and use currently idle resources in the global network at any time, even though other programs are already attached to the global network. In a network as shown in Figure 3-11, your program can send to any end user but can only receive (access) a message from its own LOCAP file.

Global network configurations in a multinode global network environment are connected by a physical link called a virtual line or VLINE. Each VLINE supports up to 4,095 logical subchannels as specified in the PORT operand of the LPORT macro. In this environment, a global network resides in each computer node, and, of course, these networks must relate to each other. Figure 3-12 illustrates an ICAM multinode global network. Typically, a node in a multinode global network has an environment similar to that shown in Figure 3-12.

Figure 3-13 illustrates various configurations of global networks.

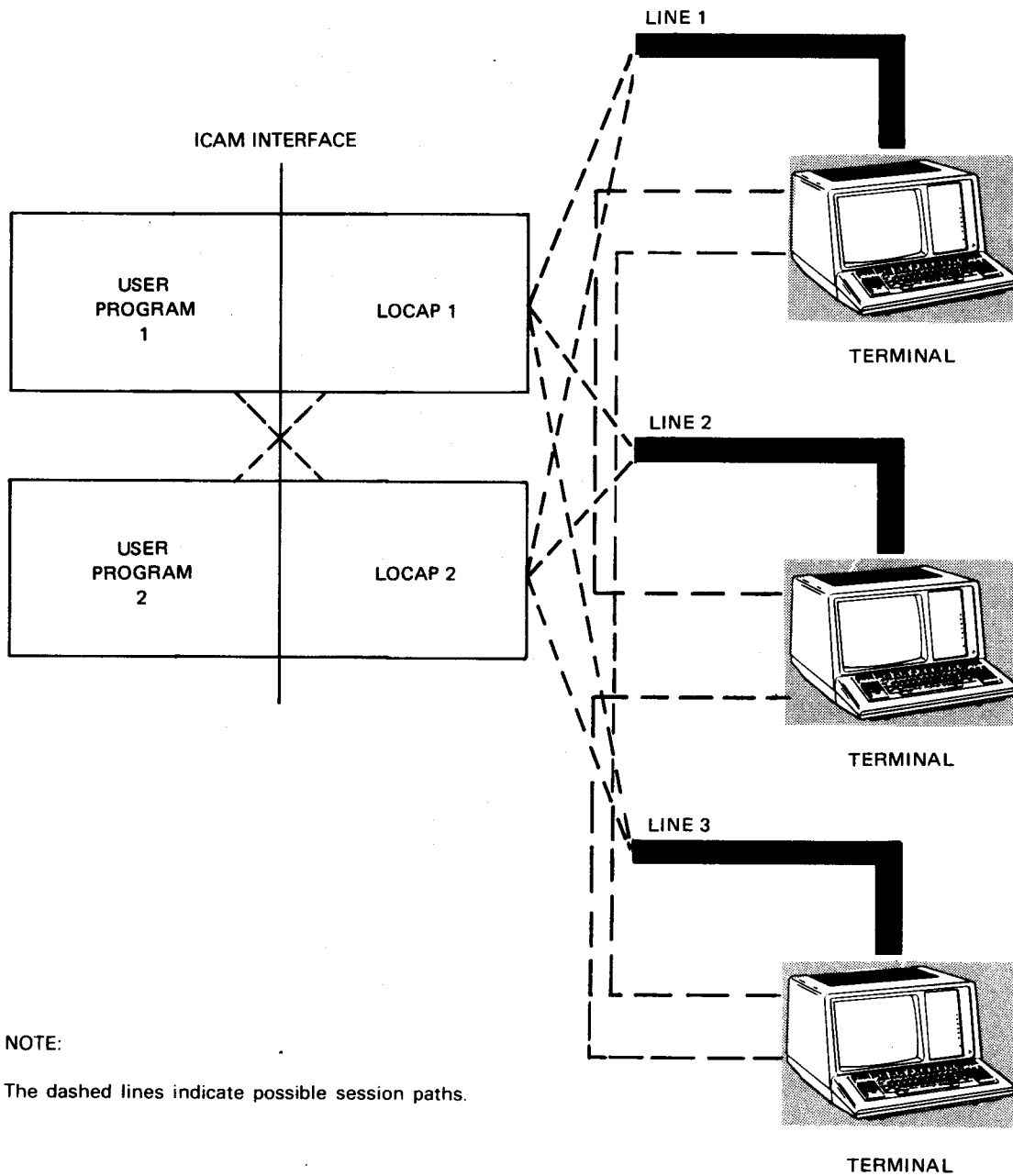

NOTE:

The dashed lines indicate possible session paths.

Figure 3-11. Single-Node Standard Interface Global Network

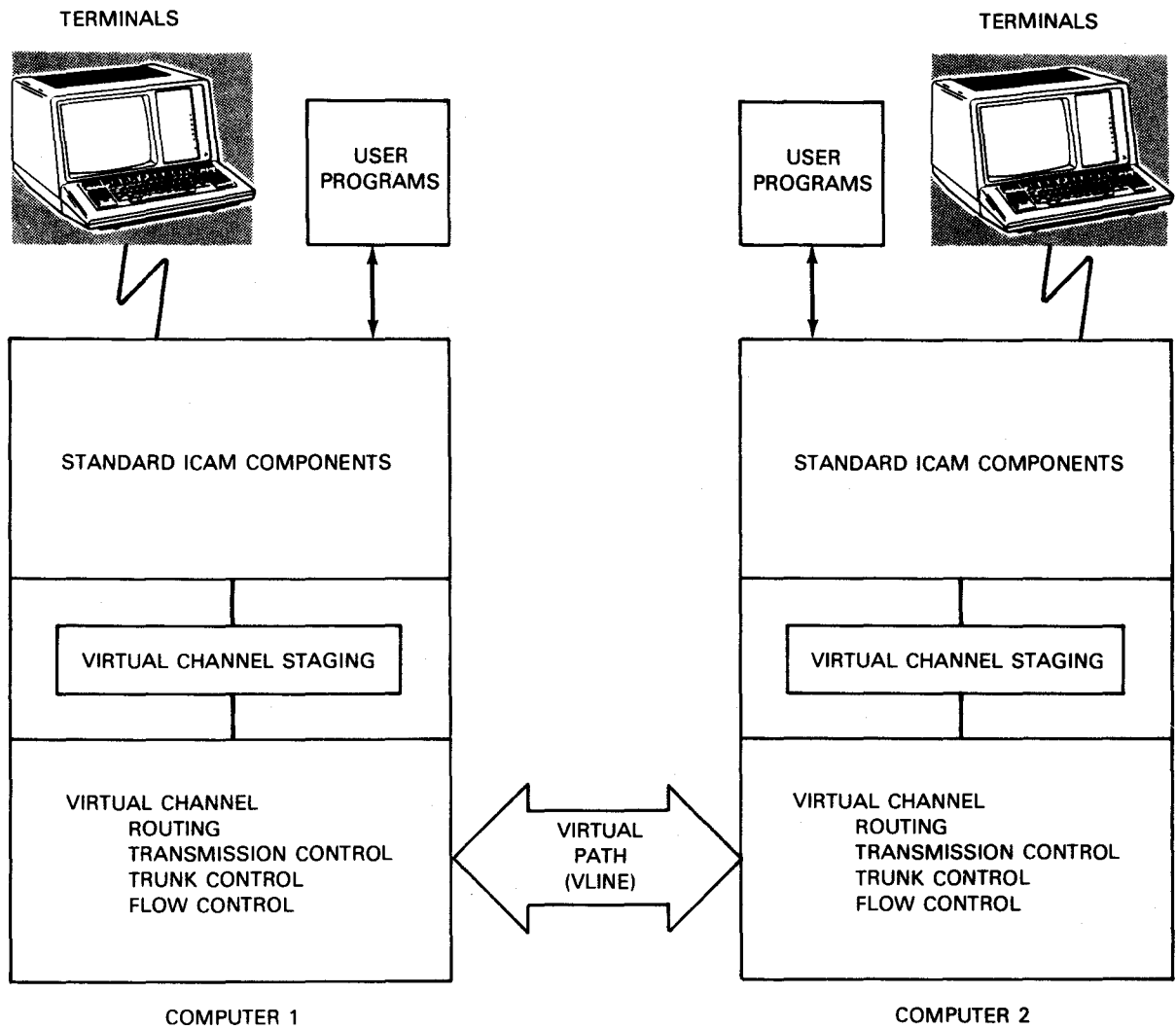

Figure 3-12. Multinode Global Network Environment

Defining Your Network

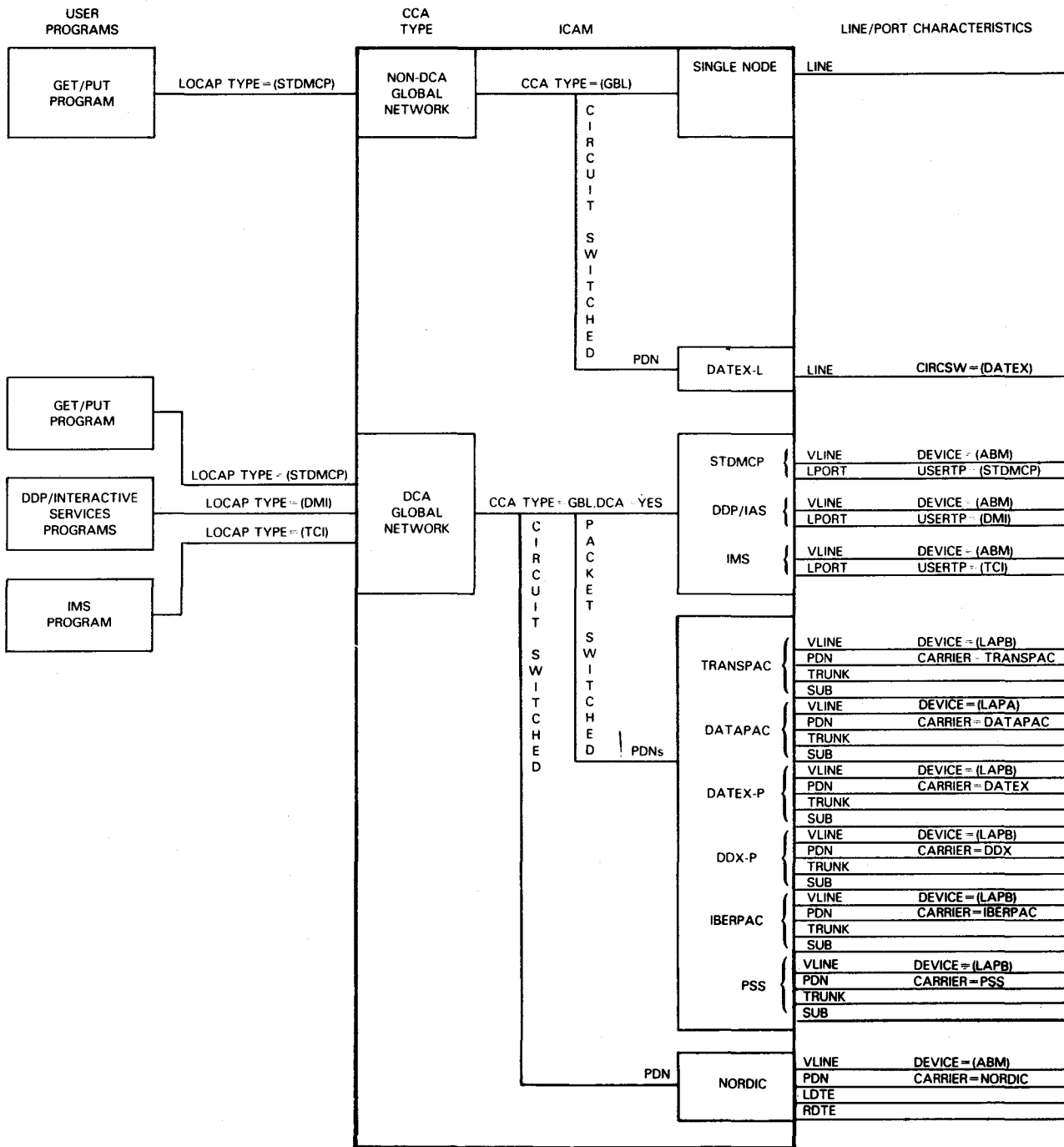

Figure 3-13. ICAM Non-DCA and DCA Global Networks

3.3.1 Order of Presentation for Global Network Definition Macroinstructions

Table 3-5 shows the recommended order of presentation for global network definitions. The order of presentation and most of the statements are the same as in an STDMCP dedicated network definition (3.2.2). This is because global networks are an extension of the STDMCP *dedicated* network concept.

As in all network definitions, the CCA macro starts a global network definition, and the BUFFERS macro defines the system requirements for network buffers and activity request packets. In a global network definition, you must specify LOCAP files for all your user programs by means of LOCAP macros inserted at this point. LINE and TERM macros follow, defining the characteristics of each line and terminal connected to it. (Output queues are defined in LINE and TERM macros by HIGH, MEDIUM, and LOW operands.) If you are using remote workstations in your network, a poll group (PGROUP) macro is required and precedes the TERM macros within that group of terminals.

Next, you specify any disk files, journal files, process files, and distribution lists you may need by means of DISCFILE, JRNFILE, PROCES, and DLIST macros.

If you want to define static (permanent) sessions between end users, you use SESSION macros. You must not specify SESSION macros for sessions that are established dynamically. At this point, you can define any message processing routines you want in the global network. Each message processing routine is introduced by an MPSTART macro. An ENDCCA macro would end the network definition here if you were defining a single node global network.

If you are defining a multinode standard interface global network, you must supply a definition for the virtual line (the physical link between two computers). Do this by means of the VLINE macro. In addition, you must define the end users in the remote computers. Do this by means of LOCAP, TERM, and PRCS macros that have the REMOTE operand specified. You must not specify LINE macros for the remote computer because lines are not considered end users.

Finally you end the network definition with the ENDCCA macro.

Only one global network definition can operate at a time in the processor. You can mix global and dedicated network definitions in the same symbiont.

Defining Your Network

Table 3-5. Order of Presentation of Macroinstructions in a Global Network Definition

Macroinstruction Name	Remarks
CCA	Specifies the beginning of a global network definition
BUFFERS	Specifies required system resources
LOCAP ₁	Specifies all local user programs, i.e., in this node
.	
LOCAP _n	
.	
LINE ₁	Specifies the characteristics of all local lines
.	
.	
PGROUP	Specifies a poll group when using remote workstations only
TERM ₁	Specifies the characteristics of the terminal on this line
EUP ₁	Specifies end user profile for this terminal (message formatting function)
.	
.	
PGROUP	
TERM _n	
EUP _n	
LINE _n	
PGROUP	
TERM ₁	
EUP ₁	
.	
.	
PGROUP	
TERM _n	
EUP _n	
DISCFIL ₁	Specifies the first disk file used for this network
.	
DISCFIL _n	Specifies the last disk file
JRNFILE ₁	Specifies the first journal file for this network
.	
JRNFILE _n	Specifies the last journal file

continued

Table 3-5. Order of Presentation of Macroinstructions in a Global Network Definition (cont.)

Macroinstruction Name	Remarks
PRCS ₁ . .	Specifies the first local process file in this network
PRCS _n	Specifies the last local process file in this network
DLIST ₁ . .	Specifies one or more distribution lists for this network
DLIST _n	
SESSION ₁ . .	Specifies the first <i>static</i> local session between local end users. (Local means in this computer node.)
SESSION _n	Specifies the last <i>static</i> local session
MPSTART ₁ . .	Specifies MPPS if required. The required MPPS macros follow the MPSTART statements.
MPSTART _n	
CONGRP	Defines the station group when NRM line control is used.
VLINE ₁	Specifies the first VLINE for this network and the resources associated with it
STATION ₁ STATION ₂	Specifies the characteristics of a station and flow control required by NRM link level control.
LPORT . .	Specifies the logical ports for VLINE ₁ (or STATION ₁ , if NRM) when distributed communications architecture is defined.
LPORT	
TERM . .	
TERM	
PRCS . .	
PRCS	Resources defined in a remote computer node
LOCAP	

continued

Table 3-5. Order of Presentation of Macroinstructions in a Global Network Definition (cont.)

Macroinstruction Name	Remarks
CGRPEND	Specifies the end of the UDLC/NRM configuration group definition.
VLINE _n	Specifies the last VLINE for this network and the resources associated with it
LPORT	Specifies logical ports for distributed communications architecture in VLINE _n .
.	
LPORT	
TERM	
.	
TERM	
PRCS	Resources defined in the remote computer node
.	
PRCS	
LOCAP	
ENDCCA	Specifies the end of this global network definition

3.3.2. Using Queues in a Global Network

- Program Queues

You can specify up to three special queues via the **HIGH**, **MEDIUM**, and **LOW** operands in a **LOCAP** macro. These queues belong only to the program named in the label of the **LOCAP** macro and only that program can access messages placed on them. Your program accesses the queues by using a **GETCP** and referencing its name in the related **DTFCP**. Any end user, such as another program, can place messages on these queues by issuing a **Put** request and addressing your program in the same manner as a process file.

If a program receiving a message resides in a remote node, defined by the **REMOTE** operand in the **LOCAP** macro, only **ICAM** can access the queues to transfer queued messages to the program located in the remote node. In this case, the queues become destination queues for the remote program.

- **Process File Queues**

Process file queues are used for temporary storage of messages destined for a program. Any program may issue a Put request to place a message on a process file or issue a Get request to access a message existing on a process file. The low, medium, and high message queues are both destination queues (the Put side) and input queues (the Get side).

If a message is directed to a process file that is located in a remote node, the message is stored on a local process file (of the same name) that has the remote operand specified. ICAM can access the Get side of this process file only to transfer a queued message over the virtual link (VLINE) to the destination process file. The final process file is local to the remote node and, therefore, any program in the remote node can access the message. This design prevents local programs from accessing process files and removing messages destined for remote nodes.

- Each terminal can have up to three output priority queues for messages destined to it. They are created via the HIGH, MEDIUM, and LOW operands on the TERM macro. In addition, a single input queue can be created for all input messages from the terminal via the INPUT=YES operand in the TERM macro. Your program accesses this input queue via the label specified on the TERM macro in the related DTFCP for the Get request.

The terminal input can be directed to any remote or local end user via the INPUT=*end-user-name* in the TERM macro. For example, if all terminal input is going to another terminal called TRM2, the label of the destination terminal in the INPUT operand of the source terminal's TERM macro is INPUT=TRM2.

3.4. Single-Node Global Networks

In a global network definition for a single node, you can specify a LOCAP macroinstruction for a user program (STDMCP), ICAM terminals as workstations connected to interactive services (DMI), or an IMS user (TCI).

The basic differences in defining single-node global networks are:

Basic Macro	Standard Interface User	Interactive Services User	IMS User
CCA	TYPE=(GBL,,node)	TYPE=(GBL,,node)	TYPE=(GBL,,node)
LOCAP	TYPE=(STDMCP)	TYPE=(DMI) ,IAS=(YES,OFF)	TYPE=(TCI)

Local workstations are directly connected to interactive services and do not require any operands or statements in an ICAM network definition. However, if a local workstation must communicate with one of your programs, you must define it in a LINE and TERM macro as follows:

Macro	Operand Affected
LINE	DEVICE=(LWS)
TERM	FEATURES= U20 ,ADDR=(dev-addr) U40

3.4.1. Single-Node Standard Interface Global Network

Figure 3-14 illustrates a single-node global network definition. Two programs use this network - CUP1 and CUP2. These are identified in the network by the two LOCAP macros. Notice that each LOCAP macro includes three operands to create input queues. The HIGH, MEDIUM, and LOW operands create input queues that enable the programs to receive input messages directly. SESSION macros are used to establish static sessions between the end users in this network. Sessions can be established dynamically by means of the ICAM dynamic session establishment feature. In this case, SESSION macros are not specified. However, if you specify a static session between a terminal and another end user, you cannot then establish dynamic sessions with that terminal.

1	72	
1.	GNSN CCA TYPE=(GBL,,S),FEATURES=(OPCOM) BUFFERS 40,64,9,ARP=35,STAT=YES,EXPFACT=50	
2.	CUP1 LOCAP TYPE=(STDMCP),LOW=FILEA,MEDIUM=FILEA,HIGH=FILEA	
3.	CUP2 LOCAP TYPE=(STDMCP),LOW=FILEA,MEDIUM=FILEA,HIGH=FILEA	
4.	LNE1 LINE DEVICE=(UNISCOPE),TYPE=(2000,SWCH,SYNC),ID=12	
5.	TRM1 TERM ADDR=(28,51),FEATURES=(U200,1920), LOW=FILEA,MEDIUM=FILEA,HIGH=FILEA, INPUT=(YES,,FILEA)	X X
	TRM2 TERM ADDR=(28,52),FEATURES=(U200,1920), LOW=FILEA,MEDIUM=FILEA,HIGH=FILEA, INPUT=(YES,,FILEA)	X X
6.	TRM3 TERM ADDR=(29,53),FEATURES=(U200,1920), LOW=FILEA, INPUT=(TRM4)	X X
	TRM4 TERM ADDR=(29,54),FEATURES=(U200,1920), LOW=FILEA, INPUT=(TRM3)	X X
7.	FILEA DISCFILE FILEDIV=15	
8.	SESSION EU1=(CUP1),EU2=(CUP2) SESSION EU1=(CUP1),EU2=(TRM1) SESSION EU1=(CUP1),EU2=(TRM2) SESSION EU1=(TRM3),EU2=(TRM4) ENDCCA	
NOTES:		
1.	Designates this network as a global network with the node name of S.	
2.	Defines a LOCAP file for CUP1 with three disk queues.	
3.	Defines a LOCAP file for CUP2 with three disk queues.	
4.	Defines a local switched synchronous line operating at 2000 baud using UNISCOPE terminals.	
5.	Defines a UNISCOPE 200 terminal on line LNE1 with a rid and sid address (28,51) with three disk output queues (all having the same name) and a disk input queue (FILEA).	
6.	Defines another UNISCOPE 200 terminal on line LNE1 with a rid and sid address of (29,53) and a low priority output queue on disk; input from terminal 3 is sent to the output queues for terminal 4.	
7.	Defines the disk file for the queues.	
8.	Defines static sessions as follows:	
	CUP1 and CUP2	
	CUP1 and TRM1	
	CUP1 and TRM2	
	TRM3 and TRM4	

Figure 3-14. Single-Node Standard Interface Global Network Definition

3.4.2. Single-Node Global Network with IMS and Local Workstations

This network definition illustrates how to create an ICAM global network that supports several user programs and IMS. The network is all contained in a single node, (i.e., all programs and IMS are contained in the same host computer). Figure 3-15 illustrates the logical arrangement of this global network, and Figure 3-16 shows the coding used to define it.

The following are some pertinent characteristics of this network:

- All the terminals are workstations, hence no single-line communications adapters are required.
- There is only one workstation per communications line, because multiple workstations on the same communications line are not supported.
- Only two static sessions are defined. These are between process file PRF1 and LOCAP file CUPP, and between LOCAP file CUPP and terminal TRM1. This means that user program CUPP can read from process file PRF1 and write to terminal TRM1 without needing to create a dynamic session. All input from TRM1 is automatically queued to process file PRF1 by ICAM. It also means that user program CUPP is the sole user of workstation TRM1, since no other user can access TRM1 due to the static session between CUPP and TRM1.
- No queues are defined for LOCAP file IMS1. This is because IMS does not require a queued interface - disk buffering is used.
- Only one workstation (TRM1) specifies an input destination. All the other workstations communicate with the user-written programs or IMS by using dynamic sessions. For example, when you are at a terminal and you need to talk to a program, you sign on with a \$\$SON command and ICAM creates the dynamic session between your terminal and the program, if possible. (The program or ICAM may reject the sign-on request for some reason, i.e., the program you requested was not loaded.) If the session command is honored, the destination you supplied in the sign-on request is used, and no destination for input is needed in the network definition. If the session is rejected, a SESSION PATH CLOSED message is sent to your terminal.

A user program issuing a SESCO macro to accept a session with a terminal always has the capability to specify the destination where input from a terminal is to be placed. The user program does this by specifying it in the INQNAME= operand in the SESCO macro. The SESCO macro is described in the *ICAM Standard MCP Interface Programming Guide (UP-8550)*.

- All the workstations can use interactive services, but they do so directly without the need of an ICAM network.

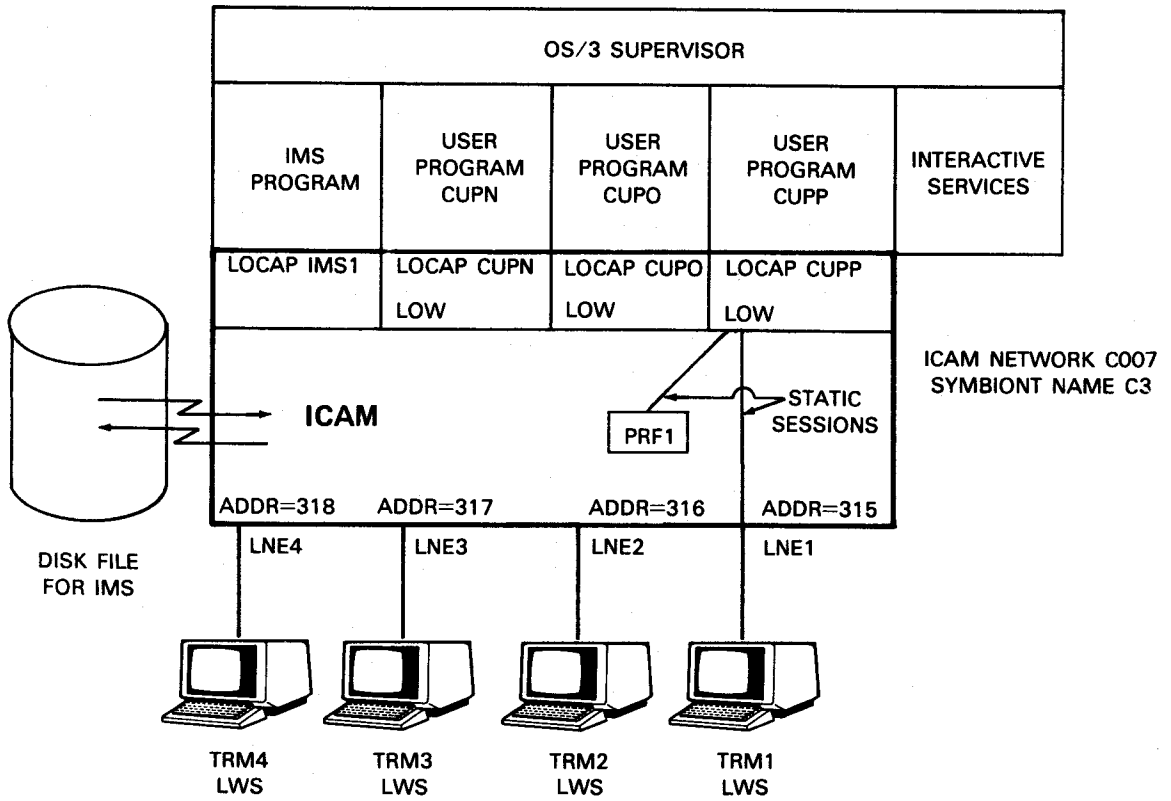

Figure 3-15. Global Network Supporting Workstations, IMS, and User-Written Programs

Defining Your Network

1	72
COMMCT	
1. C007	CCA TYPE=(GBL,,A),FEATURES=(OPCOM), GAWAKE=YES X
2.	BUFFERS 20,512,2,ARP=42,STAT=YES,EXPFACT=50
3. IMS1	LOCAP TYPE=(TCI)
	{CUPN LOCAP TYPE=(STDMCP),LOW=MAIN
	{CUPO LOCAP TYPE=(STDMCP),LOW=MAIN
	{CUPP LOCAP TYPE=(STDMCP),LOW=MAIN
5. LNE1	LINE DEVICE=(LWS),STATS=YES
6. TRM1	TERM FEATURES=(U20),ADDR=(315),LOW=MAIN, HIGH=MAIN,INPUT=PRF1 X
7. LNE2	LINE DEVICE=(LWS),STATS=YES
8. TRM2	TERM FEATURES=(U20),ADDR=(316),LOW=MAIN, HIGH=MAIN X
9. LNE3	LINE DEVICE=(LWS),STATS=YES
10. TRM3	TERM FEATURES=(U20),ADDR=(317),LOW=MAIN, HIGH=MAIN X
11. LNE4	LINE DEVICE=(LWS),STATS=YES
12. TRM4	TERM FEATURES=(U20),ADDR=(318),LOW=MAIN, HIGH=MAIN X
13. PRF1	PRCS LOW=MAIN
14. TCIFILE	DISCFILE MSGSIZE=2048
15.	SESSION EU1=(CUPP),EU2=(TRM1)
16.	SESSION EU1=(PRF1),EU2=(CUPP)
17.	ENDCCA
18.	MCP
	MCPNAME=C3
END	

NOTES:

1. Specifies a global network that includes operator communications and dynamic session capabilities.
2. Specifies that 20 network buffers, each 512 words long (2048 bytes), are required to service this network. A threshold of 2 network buffers is maintained by ICAM, and ICAM maintains statistics on network buffer and activity request packet (ARP) usage. ICAM will expand buffer pools automatically by 50% when needed.
3. Specifies a locap file name IMS1. This locap file is used by IMS.
4. Three locap files for use by standard interface user programs are defined.
5. Specifies communications line LNE1 uses workstation protocol, and ICAM is to gather line statistics.
6. Specifies workstation TRM1 is attached to address 315. Low and high priority output queues are required, and input is directed to process file PRF1.
7. Specifies communications line LNE2 uses workstation protocol, and ICAM is to gather statistics.
8. Specifies workstation TRM2 is attached to address 316. Low and high priority output queues are required.

Figure 3-16. Global Network Definition to Support Workstations, IMS, and User-Written Programs (Part 1 of 2)

9. Specifies communications line LNE3 uses workstation protocol, and ICAM is to gather line statistics.
10. Specifies workstation TRM3 is attached to address 317. Low and high priority output queues are required.
11. Specifies communications line LNE4 uses workstation protocol, and ICAM is to gather statistics.
12. Specifies workstation TRM4 is attached to address 318. Low and high priority output queues are required.
13. Defines a process file for use by user program CUPP.
14. Defines a disk file for IMS disk buffering requirements.
15. Defines a static session between locap file CUPP and workstation TRM1.
16. Defines a static session between process file PRF1 and locap file CUPP.
17. Ends this network definition.
18. Specifies that this network definition is to be saved as a symbiont called C3.

Figure 3-16. Global Network Definition to Support Workstations, IMS, and User-Written Programs (Part 2 of 2)

3.4.3. Single-Node Global Network with IMS and Terminals Using Interactive Services

User-written programs, IMS, and interactive services can coexist in the same communications network. In this single-node example, all of the terminals and programs reside in the same computer. The text describes some of the schemes that may not be completely obvious from the coding.

About the Programs:

Figure 3-17 illustrates the arrangement, and Figure 3-18 shows the coding used to define the network. In both figures, we assume that IMS uses LOCAP file IMS1, the user program uses LOCAP file CUPB, and interactive services uses LOCAP file DMI as their links to ICAM.

Figure 3-17 shows the use of multiple program support by an ICAM global network. Workstations are used as terminals communicating with IMS and user-written programs. In addition, terminals are shown communicating with interactive services.

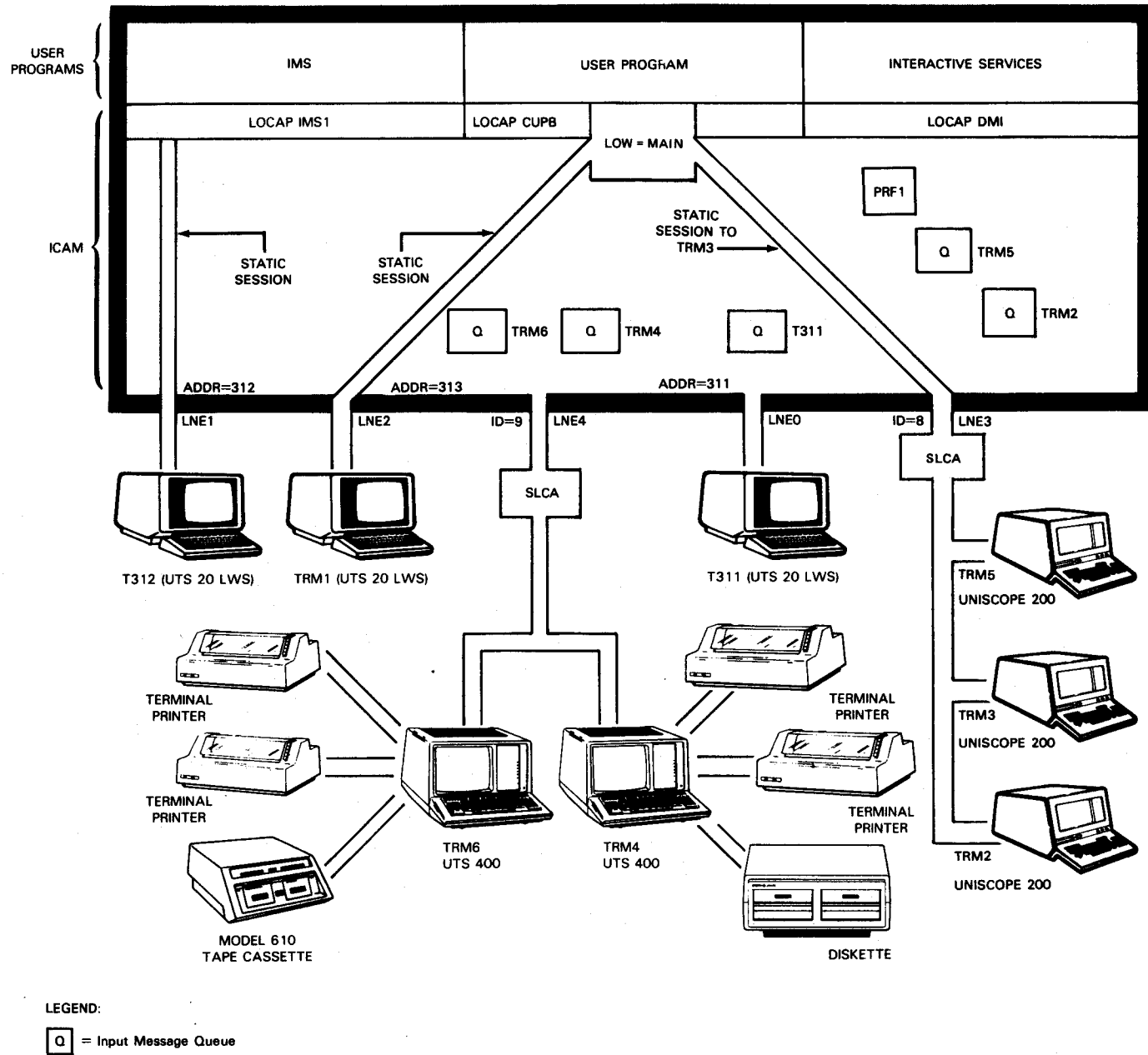

LEGEND:
 [Q] = Input Message Queue

Figure 3-17. Global Network Supporting IMS, User-Written Program, and Interactive Services

About the Terminals:

Of the eight terminals supported in this ICAM network, three are local workstations, three are UNISCOPE terminals, and two are UTS 400 terminals. In addition, one process file for CUPB and one disk file for IMS are defined. If IMS is required to support unsolicited or continuous output, a second process file with a static session would be required; since there is no static session defined for PRF1, we know that it was defined for use by CUPB. All other message traffic handled by ICAM is queued and stored in main storage.

About Sessions:

In addition to the mix of programs, terminals, and workstations, Figures 3-17 and 3-18 illustrate the use of both static and dynamic sessions. For example, if you look at the SESSION macros in Figure 3-18, you will see that the following end users are linked by static sessions: LOCAP file IMS1 and workstation T312, LOCAP file CUPB and terminal TRM1, and LOCAP file CUPB and terminal TRM3. These SESSION macros create permanent links between these end users as long as the network is active.

A SESSION macro defines a static session. Each terminal specified in a SESSION macro can only communicate with the end user specified in that static session; and no other end user can communicate with that terminal by using a dynamic session or by specifying another static session. ICAM will not create a dynamic session between end users when a session is already active; and a static session is always active.

Terminal users using static sessions do not need to sign on and specify with whom they need to communicate; and user programs do not need to dynamically establish sessions with these terminals because the sessions are already permanently created in the ICAM network. Therefore, if a certain terminal is always going to communicate with the same program, and no others, you might consider the use of a static session. Whether you use dynamic or static sessions depends strictly on your needs.

The other terminals in this example use dynamic sessions. A program using dynamic sessions wishing to communicate with another end user must initiate session requests in order to communicate with that end user, and terminal users must sign-on and specify the end user with whom they wish to communicate. Dynamic sessions provide a greater degree of flexibility in a communications network; however, they require additional coding in your program to initiate and terminate the dynamic sessions.

When you examine Figures 3-17 and 3-18 closely, you'll notice relationships that we describe in the following paragraphs. We hope that the descriptions make it easier for you to define your global network.

How End Users Communicate:

- Local workstation T311 is a UTS 20 terminal that communicates with IMS or user program CUPB using dynamic sessions. When the workstation operator signs on or program CUPB requests a session, ICAM creates the dynamic session between the two end users. Workstation T311 is automatically attached to interactive services through a LOGON command.

When your program initiates a dynamic session between itself and a terminal, it can access input from the location specified by the INPUT= operand in the TERM macro, or it can explicitly specify where input from the terminal is to be queued for its own purposes. You do this in your program by specifying the new destination in the INQNAME= operand described in the SESCON macro. (The SESCON macro can be found in the *ICAM Standard MCP Interface Programming Guide* (UP-8550).) Note that when you specify INQNAME= in your program, it always overrides the INPUT= operand specified in the network definition TERM macro.

- Workstation T312 is a UTS 20 terminal that communicates with IMS when ICAM is loaded and attached to the global network. Terminal T312 cannot communicate with user program CUPB because it is linked to IMS by a static session. Because input queuing is not required with IMS, the INPUT= operand is not specified. Workstation T312 is automatically attached to interactive services through a LOGON command.
- Workstation TRM1 communicates with CUPB using the static session defined for it. All input from TRM1 is queued directly to the low priority queue of LOCAP file CUPB. When it is not in use with CUPB, workstation TRM1 may communicate with interactive services through a LOGON command.
- UNISCOPE terminal TRM5 can communicate with IMS and user program CUPB. In addition, because TCTUPD=YES is specified, TRM5 can also communicate with interactive services. Dynamic sessions are used to permit communication.

Because an input message queue is specified (INPUT=YES), your program obtains input messages from the queue unless your program changes the destination of input messages when it requests the dynamic session (as described for T311). Because interactive services doesn't use a queued interface and IMS uses disk buffering for input, INPUT= in the TERM macro has no meaning for them.

- UNISCOPE terminal TRM2 can communicate with IMS and user program CUPB. Terminal TRM2 cannot communicate with interactive services because TCTUPD=YES is not specified; hence the software needed to access interactive services is not provided for this nonworkstation terminal. Because an input queue was established by the INPUT=YES operand in the TERM macro, your program accesses input messages from this queue unless it redefines a destination for input messages as described for terminal T311. INPUT= has no meaning for IMS.

- UNISCOPE terminal TRM3 and CUPB are linked by a static session, and all input from terminal TRM3 is queued to LOCAP file CUPB for user program CUPB. This essentially dedicates TRM3 to CUPB.
- UTS 400 terminal TRM6 may communicate with IMS, CUPB, or interactive services using dynamic sessions. This terminal also supports additional auxiliary devices. INPUT=YES specifies that input from this terminal is queued to an input message queue, however, input can be redirected by your program when it requests the dynamic session. INPUT= has no meaning for IMS or interactive services.
- UTS 400 terminal TRM4 may communicate with any program except interactive services. INPUT=YES specifies that input from this terminal is queued to an input message queue, however, input can be redirected by your program when it requests the dynamic session. INPUT= has no meaning for IMS.

1		72	
COMMCT			
1.	GBL1	CCA TYPE=(GBL,,S),FEATURES=(OPCOM,OUTDELV), FEATURES=(RESTART,SEGMENTS), GAWAKE=YES	X X
2.		BUFFERS 100,64,5,ARP=100,EXPFACT=50	
3.	IMS1	LOCAP TYPE=(TCI)	
4.	DMI	LOCAP TYPE=(DMI),IAS=(YES,OFF)	
5.	CUPB	LOCAP TYPE=(STDMCP),LOW=MAIN,MEDIUM=MAIN,HIGH=MAIN	
6.	LNE0	LINE DEVICE=(LWS),LBL=900	
7.	T311	TERM ADDR=(311),FEATURES=(U20),INPUT=YES, LOW=MAIN,MEDIUM=MAIN,HIGH=MAIN	X
8.	LNE1	LINE DEVICE=(LWS),LBL=900	
9.	T312	TERM ADDR=(312),FEATURES=(U20), LOW=MAIN,MEDIUM=MAIN,HIGH=MAIN	X
10.	LNE2	LINE DEVICE=(LWS),LBL=900	
11.	TRM1	TERM ADDR=(313),FEATURES=(U20),INPUT=(CUPB), LOW=MAIN,MEDIUM=MAIN,HIGH=MAIN	X
12.	LNE3	LINE DEVICE=(UNISCOPE),TYPE=(9600,SYNC),ID=8,STATS=YES	
13.	TRM5	TERM FEATURES=(U200,1920),ADDR=(21,51),INPUT=(YES), LOW=MAIN,MEDIUM=MAIN,HIGH=MAIN,TCTUPD=YES	X
14.	TRM2	TERM FEATURES=(U200),HIGH=MAIN,MEDIUM=MAIN,LOW=MAIN, ADDR=(21,52),INPUT=(YES)	X
15.	TRM3	TERM FEATURES=(U200),HIGH=MAIN,MEDIUM=MAIN,LOW=MAIN, ADDR=(21,55),INPUT=(CUPB)	X
16.	LNE4	LINE DEVICE=(UNISCOPE),TYPE=(9600,SYNC),ID=9,STATS=YES	

Figure 3-18. Global Network Definition to Support IMS, User-Written Program, and Interactive Services (Part 1 of 3)

1	72	
17. TRM6	TERM FEATURES=(U400,1920),ADDR=(21,51),INPUT=(YES), LOW=MAIN,MEDIUM=MAIN,HIGH=MAIN,TCTUPD=YES, AUX1=(TP,73),AUX2=(TP,74),AUX3=(TCS,75,76)	X X
18. TRM4	TERM FEATURES=(U400,1920),ADDR=(21,52),INPUT=(YES), LOW=MAIN,MEDIUM=MAIN,HIGH=MAIN, AUX1=(TP,74),AUX2=(TP,73),AUX3=(TCS,75,76)	X X
19. PRF1	PRCS LOW=MAIN,MEDIUM=MAIN,HIGH=MAIN	
20. TCIDTF	DISCFILE MSGSIZE=2000	
21.	SESSION EU1=(IMS1),EU2=(T312)	
22.	SESSION EU1=(CUPB),EU2=(TRM1)	
23.	SESSION EU1=(TRM3),EU2=(CUPB)	
24. ENDCCA		
25.	MCP MCPNAME=M4	
26. {	CACH=(08,GBL1,01)	
END	CACH=(09,GBL1,02)	

NOTES:

1. Specifies a global network with operator communications and output delivery notice support. Disk queueing routines are included to enable warm restart, and segmented processing is supported. GAWAKE=YES specifies dynamic sessions support.
2. One hundred network buffers, each 64 words long (256 bytes each) are specified, and a threshold of 5 network buffers is set; 100 activity request packets are allocated for ICAM's use. A buffer pool expansion factor of 50 % is requested.
3. Specifies a locap file to support IMS.
4. A locap file is specified to support interactive services. TYPE=DMI is specified because interactive services uses the demand mode interface to communicate with ICAM. IAS=(YES,OFF) means that interactive services is used without DICE functions.
5. A locap file is specified to support a standard interface user program (CUPB). Three main storage queues are specified.
6. Defines the first communications line in this network (LNE0). This line supports a workstation. A line buffer 900 words (3600 bytes) long is also specified.
7. Specifies a UTS 20 local workstation on address 311. FEATURES=(U20) identifies this terminal as a workstation. Notice that workstations are single station terminals, i.e., only one workstation is supported on a communications line. INPUT=YES means that an input message queue is set up to receive all messages from this workstation. Three output queues are also defined.
8. Defines the second communications line in this network (LNE1). It supports a workstation and uses a line buffer 900 words long.
9. Specifies a UTS 20 local workstation on address 312. An input message queue is not specified because this workstation supports IMS only using a dynamic session. Three output queues are specified.
10. Defines the third communications line in this network (LNE2). It supports a workstation and uses a line buffer 900 words long.

Figure 3-18. Global Network Definition to Support IMS, User-Written Program, and Interactive Services (Part 2 of 3)

11. Specifies a UTS 20 local workstation on address 313. All input to the host processor from this workstation is queued to the low priority queue of locap file CUPB.
12. Specifies the fourth line in this network (LNE3). It operates with UNISCOPE line protocol, line speed is 9600 baud, and the transmission mode is synchronous. ID=8 identifies the single line communications adapter (SLCA) used. STATS=YES means that ICAM accumulates statistics for all terminals connected to this communications line.
13. Defines the first of three terminals (TRM5) connected to this communications line (LNE3). It is a UNISCOPE 200 terminal with a screen size of 1920 characters. Its rid,sid polling address is 21,51, and input from this terminal is queued to an input message queue. TCTUPD=YES means this terminal can communicate with interactive services. Three main storage output queues are defined.
14. Defines the second UNISCOPE 200 terminal (TRM2) on this communications line. Three main storage output queues are specified, its rid,sid polling address is 21,52, and all input is queued to an input message queue. Because this terminal never needs to communicate with interactive services, TCTUPD=YES is not specified as was done for terminal TRM5.
15. Defines the third UNISCOPE 200 terminal (TRM3) on this line. It has three main storage output queues, its rid,sid polling address is 21,55, and all input from this terminal is placed on the low priority queue of locap file CUPB.
16. Specifies the fifth communications line in this network (LNE4). The line is synchronous, runs at 9600 baud, and uses UNISCOPE line protocol. Its SLCA number is 9 and ICAM collects statistics for all terminals connected to this communications line.
17. Defines a UTS 400 terminal with a screen size of 1920 characters. Its rid,sid polling address is 21,51, and all input to the host processor is placed on an input message queue. Three main storage output queues are required. TCTUPD=YES means this terminal can communicate with interactive services. This terminal also supports a tape cassette unit (or a diskette subsystem).
18. Defines a UTS 400 terminal with a screen size of 1920 characters. Its rid,sid polling address is 21,52, and all of its input is queued to an input message queue. Three main storage output queues are required. Two terminal printers and one tape cassette or diskette subsystem is supported. This terminal does not access interactive services, hence TCTUPD=YES is not specified.
19. Defines a process file (PRF1) for use by CUPB.
20. Defines a disk file for use by IMS.
21. Defines a static session between locap file IMS1 and workstation T312.
22. Defines a static session between locap file CUPB and workstation TRM1.
23. Defines a static session between terminal TRM3 and locap file CUPB.
24. ENDCCA specifies the end of this network definition.
25. MCPNAME=M4 specifies the name of the symbiont where this ICAM network is stored.
26. CACH statements are system generation parameters and are discussed more fully in the appropriate system installation user guide for the operating system. These CACH statements specify the SLCA. GBL1 is the name of the network or communications control area (CCA). Lines 04 and 05 in network GBL1 (the fourth and fifth LINE macroinstructions in the network definition) are the first and second lines that are mapped to the SLCA's. (Local workstations are not connected to SLCA's; therefore, the CACH statement with relative line 1 maps with the LNE4 LINE macroinstruction and the CACH statement with relative line 2 maps with the LNE5 LINE macroinstruction. When the network is generated, ICAM uses this information to load the single line communications adapters with the correct code needed to service the communications lines specified.

Figure 3-18. Global Network Definition to Support IMS, User-Written Program, and Interactive Services (Part 3 of 3)

3.4.4. Single-Node Global Network with Remote Workstations

This network definition illustrates how to create a single-node global network that supports remote workstations. Figure 3-19 shows the logical arrangement of the network, and Figure 3-20 shows how to define it. These are the most significant characteristics of this network:

- You must specify `DCA=YES` in the `CCA` macro.
- You must specify `UDUCT` and `LINKPAK` parameters on the `BUFFERS` macro.
- All remote workstations are connected via synchronous line adapters. Multiple workstations may be attached to a line.
- You must specify `DEVICE=(RWS)` and `TYPE=(SYNC)` for the `LINE` macro.
- You identify a terminal as a remote workstation on the `FEATURES` operand of the `TERM` macro. You can use `UTS 20`, `UTS 30`, `UTS 40`, `PC`, `SVT 1123`, or `SVT 1124` terminals as remote workstations. These terminals must be hardware configured as single station terminals (not workstations configured for cluster controllers).
- You must classify remote workstations into polling groups. To do this, precede the `TERM` macros (that identify the remote workstations) you want in a particular polling group with a `PGROUP` macro.
- You can operate a remote workstation in two modes: system mode or workstation mode. When you first log on a workstation, the workstation is initially placed in workstation mode. To establish an ICAM dynamic session to a terminal or user program, enter a `$$$SON` (sign-on) command (see 6.2). To perform a system function, such as interactive services, you press the `FUNCTION` and `SYS` (system mode) keys simultaneously.

System mode allows you to perform system type operations such as using interactive services, job control processing, entering system commands, and responding to system messages. Workstation mode allows you to sign on to ICAM for communications with IMS or standard interface user programs.

When you define a network to use remote workstations, you must define a `LOCAP` file as `TYPE=DMI` and `MODE=SYSTEM`. If you are going to operate in workstation mode to communicate with ICAM, define a `LOCAP` file with `TYPE=TCI` for IMS or `TYPE=STDMCP` for standard interface user programs. Multiple `LOCAP` files may be specified for multiple user program applications, but only one system mode `LOCAP` file may be specified per network. Note that remote workstations cannot be used for multinode operations.

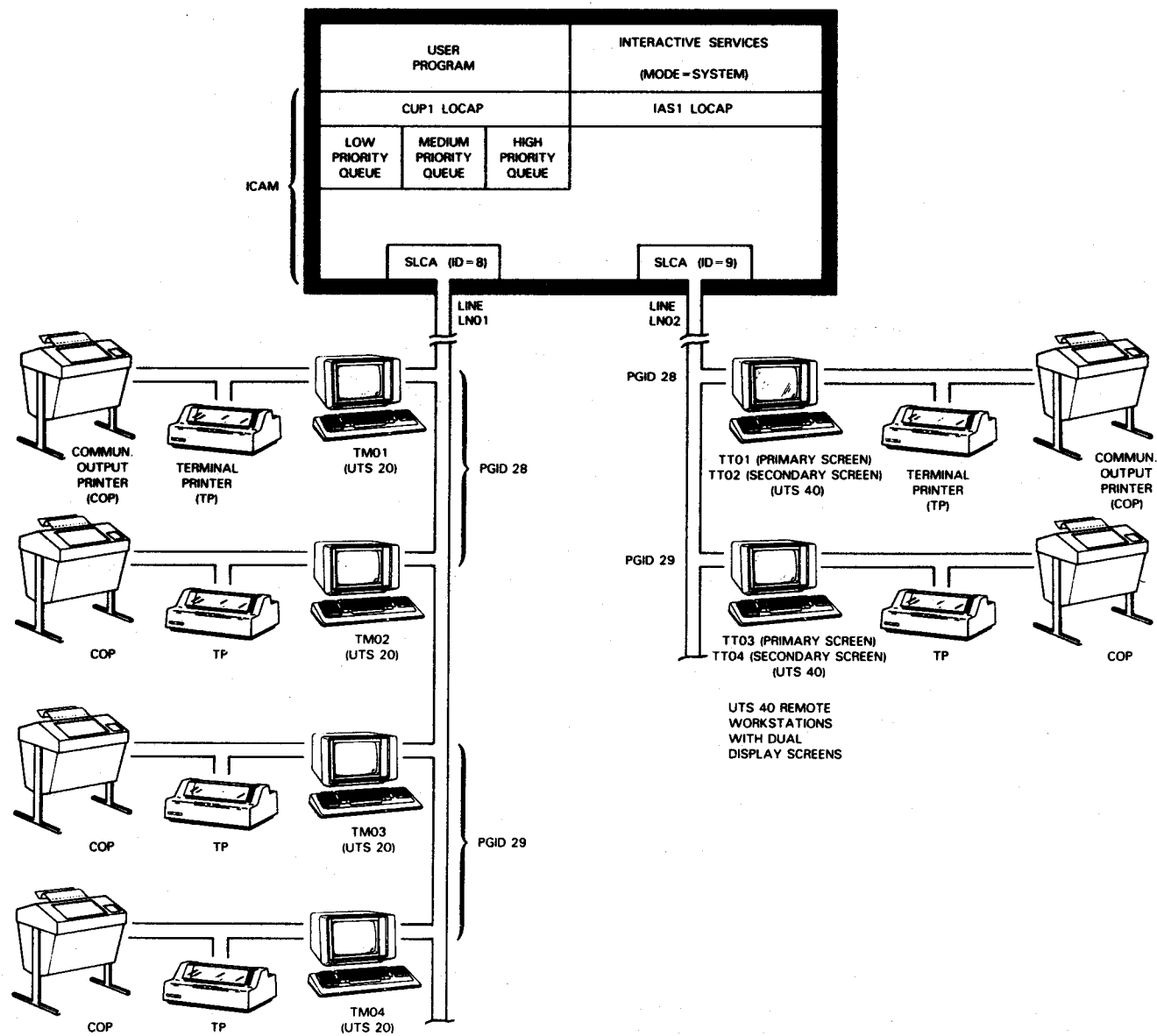

Figure 3-19. Global Network with Remote Workstations

1	72
1. RWSA	CCA TYPE=(GBL,,A),FEATURES=(OPCOM), GAWAKE=YES,DCA=YES X
2.	BUFFERS 200,64,0,ARP=50,STAT=YES, UDUCT=(16,28,2),LINKPAK=(24,80,3) X
3. IAS1	LOCAP TYPE=(DMI),MODE=SYSTEM,IAS=(YES,OFF)
4. CUP1	LOCAP TYPE=(STDMCP),LOW=MAIN,MEDIUM=MAIN, HIGH=MAIN X
5. LN01	LINE DEVICE=(RWS),TYPE=(9600,SWCH,SYNC),ID=8, RETRY=(6,4) X
6.	PGROUP PGID=28
7. TM01	TERM FEATURES=(U20,1920),ADDR=(28,51),HIGH=MAIN,MEDIUM=MAIN, LOW=MAIN,AUX1=(COP,73),AUX2=(TP,74) X
8. TM02	TERM FEATURES=(U20,1920),ADDR=(28,52),HIGH=MAIN,MEDIUM=MAIN, LOW=MAIN,AUX1=(COP,73),AUX2=(TP,74) X
9.	PGROUP PGID=29,PTIME=(2,60)
10. TM03	TERM FEATURES=(U20),ADDR=(29,51),HIGH=MAIN,MEDIUM=MAIN, LOW=MAIN,AUX1=(COP,73),AUX2=(TP,74) X
11. TM04	TERM FEATURES=(U20,960),ADDR=(29,52),HIGH=MAIN,MEDIUM=MAIN, LOW=MAIN,AUX1=(COP,73),AUX2=(TP,74) X
12. LN02	LINE DEVICE=(RWS),TYPE=(9600,SWCH,SYNC),ID=9
13.	PGROUP PGID=28,PTIME=(1,60)
14. TT01	TERM FEATURES=(U40,,,PRIMARY),ADDR=(28,51),HIGH=MAIN, MEDIUM=MAIN,LOW=MAIN,AUX1=(COP,73),AUX2=(TP,74) X
15. TT02	TERM FEATURES=(U40,,,SECONDARY),ADDR=(28,52),HIGH=MAIN, MEDIUM=MAIN,LOW=MAIN,AUX1=(COP,73),AUX2=(TP,74) X
16.	PGROUP PGID=29,PTIME=(4,60)
17. TT03	TERM FEATURES=(U40,,,PRIMARY),ADDR=(29,51),HIGH=MAIN, MEDIUM=MAIN,LOW=MAIN,AUX1=(COP,73),AUX2=(TP,74) X
18. TT04	TERM FEATURES=(U40,,,SECONDARY),ADDR=(29,52),HIGH=MAIN, MEDIUM=MAIN,LOW=MAIN,AUX1=(COP,73),AUX2=(TP,74) X
	ENDCCA

NOTES:

1. Specifies a single node global network using distributed communications architecture that includes operator communications and dynamic session capabilities.
2. Specifies 200 network buffers, each 64 words (256 bytes) in length. Statistics are to be maintained. Distributed data processing data unit control tables and link buffers are included.
3. Specifies a locap file named IAS1 is used for system mode interactive services. Priority queues are not specified because interactive services uses the DMI interface to communicate with end users, and queuing does not apply in this interface.
4. Specifies a locap file named CUP1. It is used to enable a remote workstation (in workstation mode) to communicate with a user program. Because communications is via the standard interface, queues are required. We specified three: low, medium, and high.
5. Specifies that communications line LN01 services remote workstations. It is connected to SLCA 8 (ID=8).

Figure 3-20. Global Network Supporting Remote Workstations and System Mode of Operations (Part 1 of 2)

6. Specifies that the following workstations belong to this polling group (rid 28). This poll group uses a default value of 1 second for a normal poll interval and 60 seconds for a slow poll interval.
7. Specifies that remote workstation TM01 is a UTS 20 terminal with a screen size of 1920 characters. Low, medium, and high priority output queues reside in main storage. A communications output printer (COP) and a terminal printer (TP) are the auxiliary devices.
8. Specifies that remote workstation TM02 is a UTS 20 terminal. All of the parameters are the same as 7 except in the ADDR operand.
9. Specifies that following workstations belong to a new poll group. The polling interval is specified as 2 seconds for normal poll and 60 seconds for slow poll.
10. Specifies that remote workstation TM03 is a UTS 20 terminal with default screen size of 1920 characters. The remaining parameters are the same as 7 and 8 except in the ADDR operand.
11. Specifies that remote workstation TM04 is a UTS 20 terminal with a screen size of 960 characters.
12. Specifies that communications line LN02 services remote workstations.
13. Specifies that the following workstations TT01 and TT02 belong to the same polling group as 6 and explicitly states the normal and slow polling time intervals.
14. Specifies that remote workstation communications is with the primary screen of a UTS 40 remote workstation. The default designates a screen size of 1920 characters.
15. Specifies that remote workstation communications is with the secondary screen of a UTS 40. All other parameters are the same as 14 except in the ADDR operand.
16. Specifies that workstations TT03 and TT04 belong to a new polling group (rid 29). The normal polling interval is different. It also states a normal polling interval of 4 seconds and a slow polling interval of 60 seconds.
17. Specifies that remote workstation communications is with the primary screen of a UTS 40 remote workstation.
18. Specifies that remote workstation communications is with the secondary screen of a UTS 40 remote workstation.

Figure 3-20. Global Network Supporting Remote Workstations and System Mode of Operations (Part 2 of 2)

3.5. DCA Global Networks

DCA global networks can be configured as multinode networks to support user-written programs that use the standard interface, information management system (IMS), interactive services, or distributed data processing (DDP). DCA global networks also support most public data networks (PDNs) and distributed communications processors (DCPs).

DCA multinode global networks require the use of dynamic sessions. The `GAWAKE=YES` and `DCA=YES` operands must be specified in the `CCA` macro to permit dynamic session establishment/disestablishment requests from a remote terminal or remote computer node. The `SESSION` macro is not used, since it defines end users for static sessions only. Instead, the `GAWAKE` macro enables your program to be awakened and receive datagrams; the `SESCON` macro enables your program to dynamically request (or accept) the establishment of a dynamic session.

You must define a `locap` file (via the `LOCAP` macro) for all DCA applications as follows:

- Standard interface user program - specify `TYPE=(STDMCP)`
- IMS programs - specify `TYPE=(TCI)`
- Interactive services and distributed data processing - specify `TYPE=(DMI)`

When DCPs are used in DCA networks, interactive terminals can be used in the standard interface or the transaction interface (IMS) or demand mode interface (DMI).

Distributed communications processors are controlled by the Telcon communications network subsystem software. The `ICAM` network definition must therefore match certain labels and parameters of the configuration statements used to generate the Telcon network. See Appendix A for detailed information on relating Telcon and `ICAM` networks.

The `DVCGID` and `REMOTE` operands of `TERM` macros are used for all remote terminals in a DCA multinode network. The `PROTYP` operand of a `TERM` macro defaults to `DEV` for a DCA multinode network.

The `REMOTE` operand of a `LOCAP` macro is used for all remote `LOCAP`s in a DCA multinode network.

Virtual lines (`VLINEs`) for all these DCA multinode configurations are `UDLC` asynchronous balanced mode (`ABM`). Logical ports, defined by the `LPORT` macro, are used for all DCA networks with the exception of public data networks to specify the remote session end user ports.

Summarizing all the multinode DCA configurations, except the public data networks and DCPs, the ICAM network definitions would include the following:

		DCA <u>Standard</u>	DCA <u>IMS</u>	DCA <u>IS/DDP</u>
CCA	TYPE=	(GBL,,node)	(GBL,,node)	(GBL,,node)
	DCA=	YES	YES	YES
	GAWAKE=	YES	YES	YES
VLINE	DEVICE=	ABM	ABM	ABM
LOCAP	TYPE=	(STDMCP)	(TCI)	(DMI)
TERM				
LPORT	USERTP=	STDMCP	TCI	DMI

Multinode DCA global networks also support all circuit-switched and packet-switched public data networks, except DATEX-L. (See 3.6.)

Table 3-2 summarizes the basic differences in specifying network definitions for dedicated, single-node global and DCA global network configurations.

Figures 3-21 through 3-32 show multinode global networks with various distributed communications architecture configurations. The shaded operands illustrate the basic differences in the configurations.

Defining Your Network

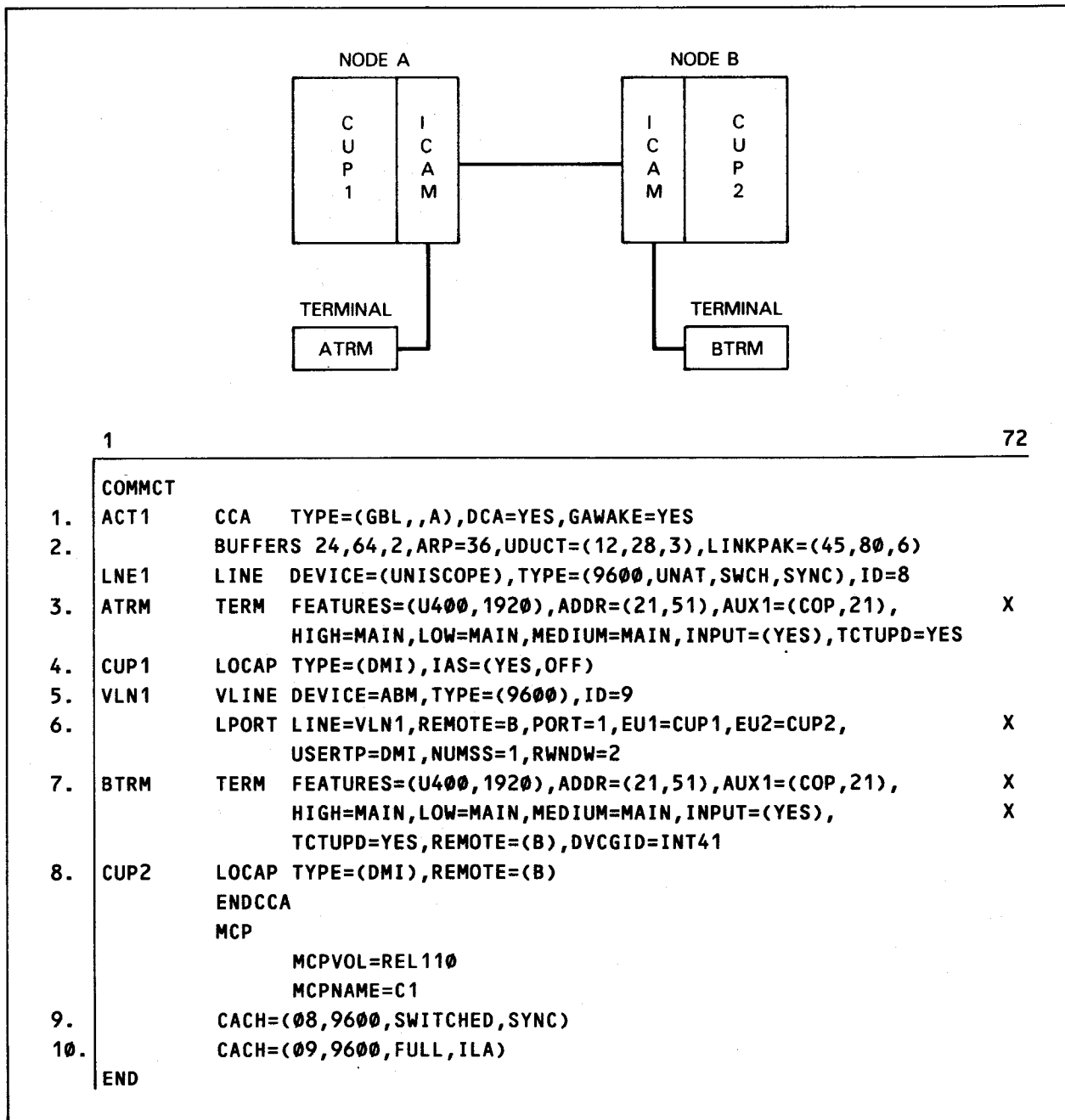

Figure 3-21. DCA Multinode Network Definition for Distributed Data Processing (Part 1 of 2)

NOTES:

1. DCA global network with a dynamic session capability
2. Specifies the buffering requirements to support DCA and DDP
3. Defines a UTS 400 terminal with 3 output queues and auxiliary devices that will communicate with interactive services
4. Specifies a LOCAP file (TYPE=DMI) defined to support distributed data processing environment
5. Specifies a virtual line with asynchronous balanced mode (ABM) link to a remote node in a distributed data processing environment.
6. Port 1 for the logical port with demand mode interface sessions between user programs CUP1 and CUP2
7. Defines a remote UTS 400 terminal that uses interactive services
8. Definition of the remote locap file (in the other computer) using distributed data processing
9. Line (LNE1) is defaulted to half duplex.
10. Defines line used by VLN1. Virtual line is full duplex with intelligent line adapter.

Figure 3-21. DCA Multinode Network Definition for Distributed Data Processing (Part 2 of 2)

Defining Your Network

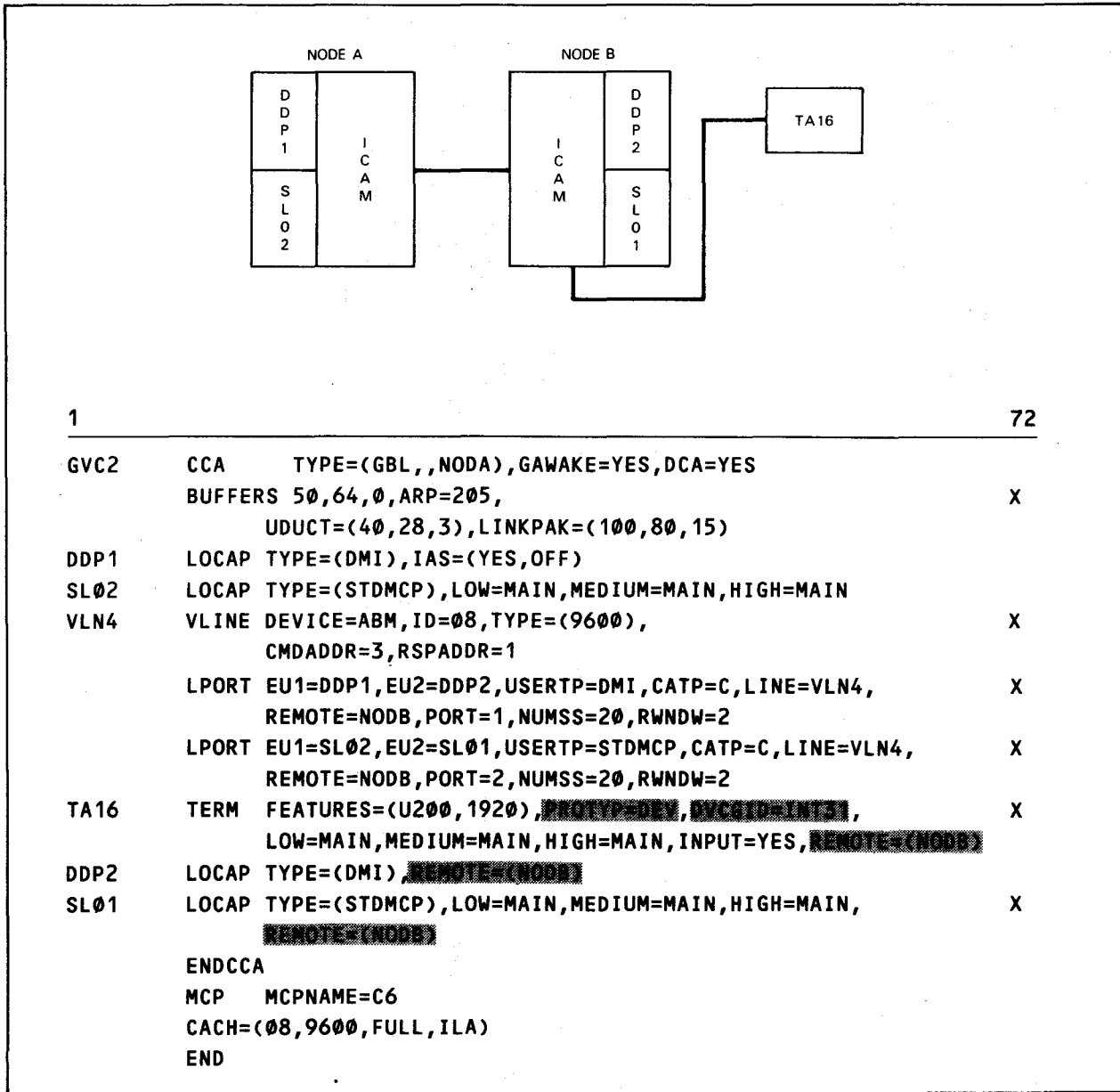
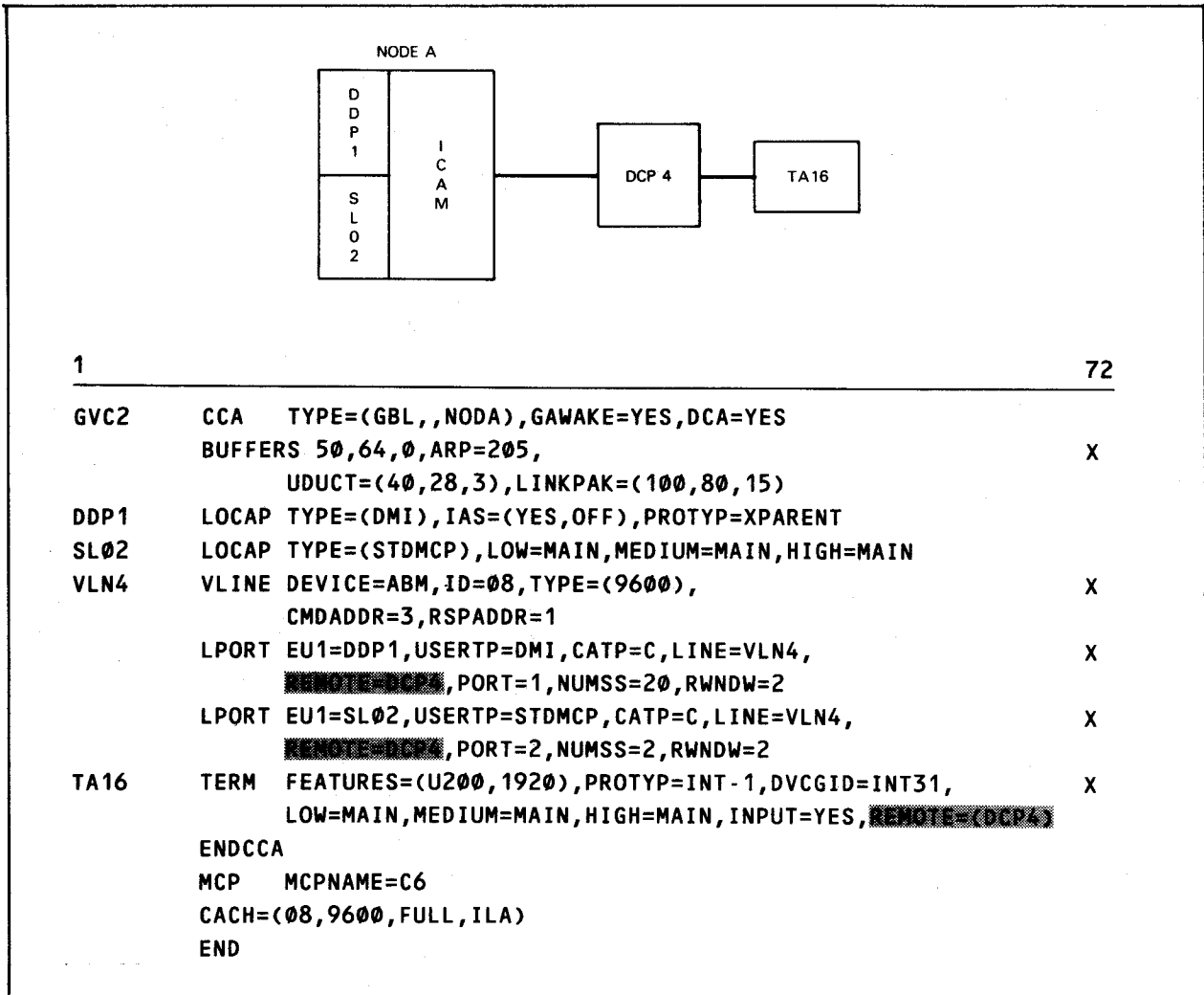

Figure 3-22. Multinode Distributed Data Processing with Interactive Terminal



```

1                                                                 72
-----
GVC2   CCA   TYPE=(GBL,,NODA),GAWAKE=YES,DCA=YES
        BUFFERS 50,64,0,ARP=205,
        UDUCT=(40,28,3),LINKPAK=(100,80,15)
        X
DDP1   LOCAP TYPE=(DMI),IAS=(YES,OFF),PROTYP=XPARENT
SL02   LOCAP TYPE=(STDMCP),LOW=MAIN,MEDIUM=MAIN,HIGH=MAIN
VLN4   VLINE DEVICE=ABM,ID=08,TYPE=(9600),
        CMDADDR=3,RSPADDR=1
        X
        LPORT EU1=DDP1,USERTP=DMI,CATP=C,LINE=VLN4,
        REMOTE=DCP4,PORT=1,NUMSS=20,RWNDW=2
        X
        LPORT EU1=SL02,USERTP=STDMCP,CATP=C,LINE=VLN4,
        REMOTE=DCP4,PORT=2,NUMSS=2,RWNDW=2
        X
TA16   TERM  FEATURES=(U200,1920),PROTYP=INT-1,DVCGID=INT31,
        LOW=MAIN,MEDIUM=MAIN,HIGH=MAIN,INPUT=YES,REMOTE=(DCP4)
        X
        ENDCCA
        MCP   MCPNAME=C6
        CACH=(08,9600,FULL,ILA)
        END
  
```

Figure 3-23. Interactive Terminal with Distributed Communications Processor (DCP)

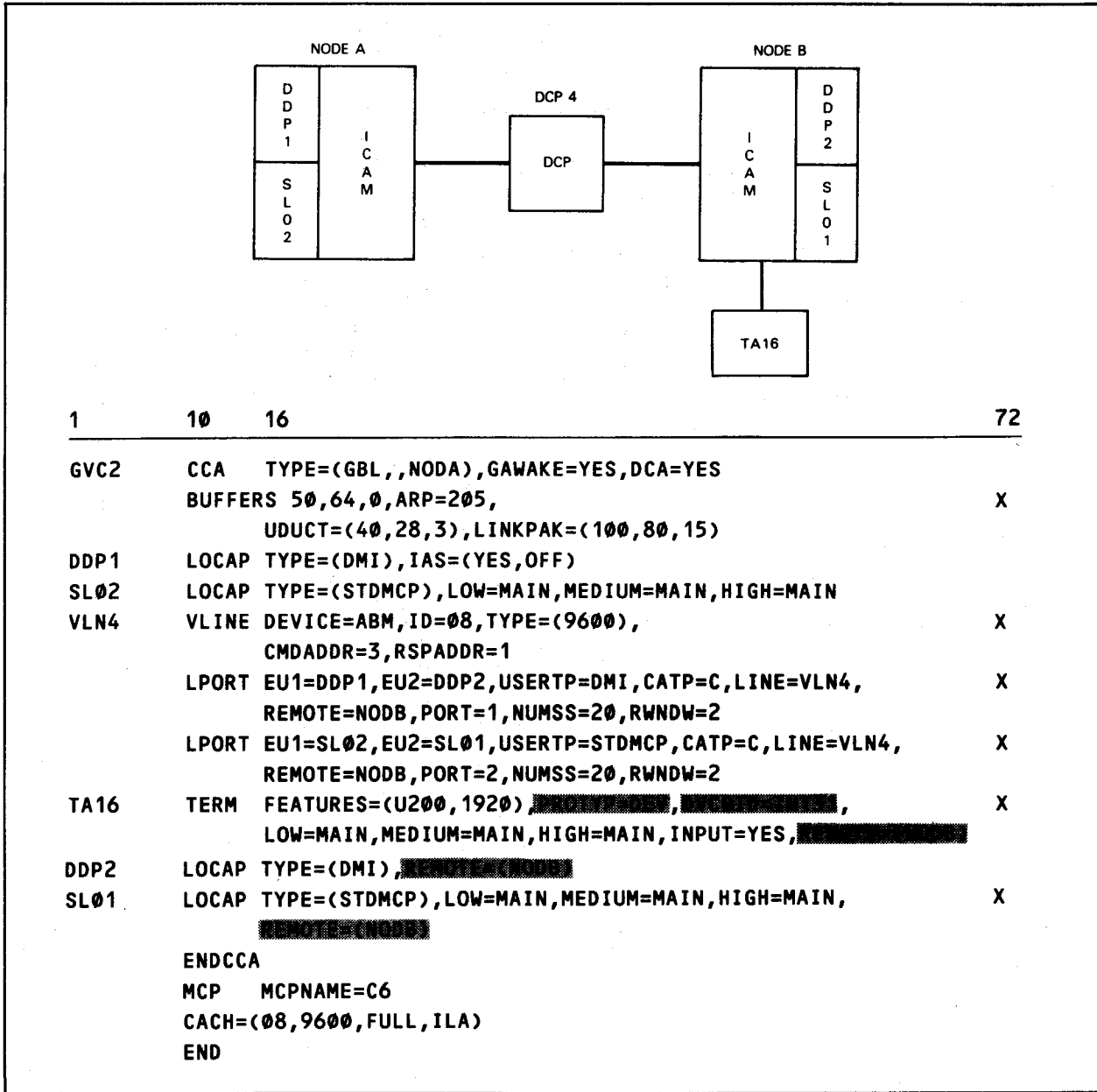

Figure 3-24. Distributed Data Processing with a Distributed Communications Processor as an Intermediate Node

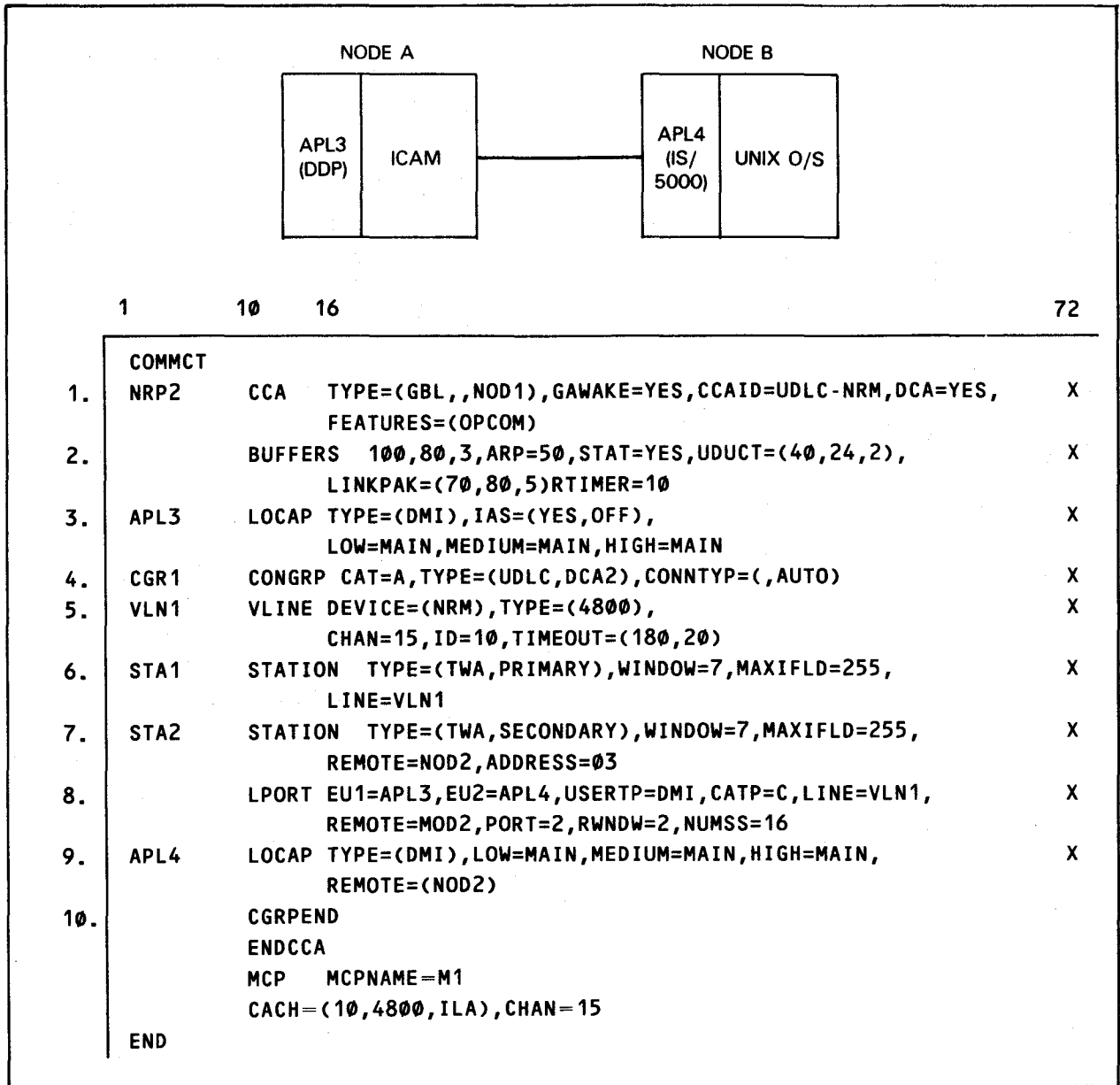

Figure 3-25. DCA Network Using NRM to Transfer Files between an OS/3 and a UNIX O/S (Part 1 of 2)

NOTES:

1. DCA global network with a dynamic session capability
2. Specifies the buffering requirements to support DCA and DDP
3. Specifies a LOCAP file (TYPE=DMI) defined to support distributed data processing environment
4. Indicates an NRM connection utilizing DCA level 2 communications
5. Specifies a virtual line with a normal response mode (NRM) link to a remote node in a distributed data processing environment
6. Defines *this* computer node as the primary station for the applicable VLINE (VLN1)
7. Defines NOD2 as containing the secondary station
8. Definition of the end users and remote site
9. Specifies the remote LOCAP
10. Indicates the end of the CONGRP

Figure 3-25. DCA Network Using NRM to Transfer Files between an OS/3 and a UNIX O/S
(Part 2 of 2)

1	10	16	72
COMMCT			
JER1	CCA	TYPE=(GBL,,NOD1),GAWAKE=YES,CCAID=UDLC-NRM,DCA=YES, FEATURES=(OPCOM)	X
		BUFFERS 100,80,3,ARP=50,STAT=YES,UDUCT=(40,24,2), LINKPAK=(70,80,5),RTIMER=10	X
APL1	LOCAP	TYPE=(STDMCP),LOW=MAIN,MEDIUM=MAIN,HIGH=MAIN	
APL3	LOCAP	TYPE=(DMI),IAS=(YES,OFF), LOW=MAIN,MEDIUM=MAIN,HIGH=MAIN	X
CGR1	CONGRP	CAT=A,TYPE=(UDLC,DCA2), CONGRP=PASSIVE,AUTO	
VLN1	VLINE	DEVICE=(NRM),TYPE=(2400,SWCH, UNIT), CHAN=15,ID=10,TIMEOUT=(180,20)	X
STA1	STATION	TYPE=(TWA,PRIMARY),WINDOW=7,MAXIFLD=255, LINE=VLN1	X
STA2	STATION	TYPE=(TWA,SECONDARY),WINDOW=7,MAXIFLD=255, REMOTE=NOD2,ADDRESS=03	X
	LPORT	EUI=APL1,EU2=APL2,USERTP=STDMCP,CATP=C,LINE=VLN1, REMOTE=NOD2,PORT=1,RWNDW=2	X
	LPORT	EU1=APL3,EU2=APL4,USERTP=DMI,CATP=C,LINE=VLN1, REMOTE=NOD2,PORT=2,RWNDW=2,NUMSS=16	X
APL2	LOCAP	TYPE=(STDMCP),LOW=MAIN,MEDIUM=MAIN,HIGH=MAIN, REMOTE=(NOD2)	X
APL4	LOCAP	TYPE=(DMI),LOW=MAIN,MEDIUM=MAIN,HIGH=MAIN, REMOTE=(NOD2)	X
	CGRPEND		
	ENDCCA		
	MCP	MCPNAME=C5	
	CACH	=(10,2400,SWITCHED,ILA),CHAN=15	
END			

Figure 3-26. DCA Network Using NRM to Transfer Files between an OS/3 and UNIX O/S Using a Switched Line

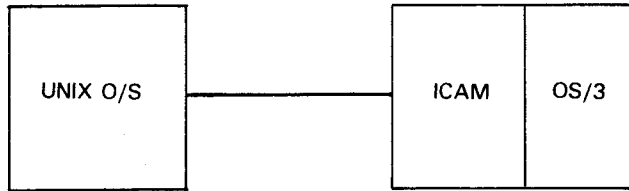

```

1      10      16      72
1.    COMMCT
2.    ASYN      CCA      TYPE=(GBL,,N),
                               FEATURES=(OPCOM,OUTDELV)      X
3.
4.    UNX0      LOCAP    TYPE=(STDMCP),LOW=MAIN,DUSTERR=INLINE
5.    ASY1      LINE     DEVICE=(TTYEM),
                               ID=06,
                               TYPE=(4800,FLDQ,FULL)          X
6.    UX00      TERM     FEATURES=(TTYEM),
                               INPUT=(YES),
                               LOW=MAIN,
                               DICE=(OFF),
                               XLATE=(NO,NO)                   X
7.
8.    SESSION   PRIMARY,EU1=(UNX0),EU2=(UX00)
9.    ENDCCA
10.   MCP       MCPNAME=C1
                               CACH=(06,ASYN,01)
10.   END
  
```

Figure 3-27. OS/3 to UNIX O/S Connectivity: SVT Emulation (Part 1 of 2)

NOTES:

1. Signals the start of an ICAM generation
2. DCA global network
3. Specifies the buffering requirements
4. LOCAP name. A maximum of ten LOCAPs may be specified. Each LOCAP must have an associated LINE specified, and each LINE must have an associated TERM specified. LOCAP names must be UNX0 through UNX9 (zero thru nine).
5. Full duplex asynchronous line using the TTYEM handler. Full duplex must be specified.
6. Terminal name specification indicating TTYEM. The TERM names must be UX00 through UX09 (zero zero thru zero nine).
7. Establishes a static session between the LOCAP and the terminal
8. Indicates the end of the CCA generation
9. Indicates the name of the ICAM network and specifies the channel hardware assignments
10. Indicates the end of the ICAM generation

Figure 3-27. OS/3 to UNIX O/S Connectivity: SVT Emulation (Part 2 of 2)

3.6. Programming ICAM for Public Data Networks

When a public data network (PDN) is the communication service that you are using for System 80, write your ICAM network definition to meet the PDN requirements.

ICAM supports the following circuit-switched and packet-switched public data networks, all of which require a global DCA network except DATEX-L. The DATEX-L PDN is described in 3.6.3.

Circuit-Switched Networks

NORDIC - Denmark, Finland,
Norway, Sweden DATEX-P -
DATEX-L - West Germany

Packet-Switched Networks

DATAPAC - Canada
West Germany
DDX - Japan
IBERPAC - Spain
PSS - United Kingdom
TRANSPAC - France

In all public data networks, except DATEX-L, the local resources are defined first via the LINE, TERM, and LOCAP macros. The PDN macro then declares the start of a public data network definition and specifies the carrier and type (circuit- or packet-switched). The associated virtual line (VLINE) follows with its appropriate protocol: UDLC asynchronous balanced mode (ABM) for circuit-switched PDNs, or link access procedure A or B (LAPA/LAPB) for packet-switched PDNs. The protocol used depends on the public data network carrier you use. Following the VLINE macro, the macros unique to public data networks are specified according to their carrier type.

In the network definitions that follow, only the public data network requirements are described, although other non-PDN communications devices might also be included in the same network. For example, an extensive ICAM network may support a public data network connection, some local workstations, several remote workstations, and a number of dial lines. However, ICAM cannot support both circuit-switched and packet-switched definitions in the same network.

3.6.1. Circuit-Switched Public Data Networks

The circuit-switched PDN establishes a dedicated physical connection between two data terminal equipments (DTE), your System 80 computers, for the transmission of a single message. The PDN interface units between the two DTEs are called data communication equipment (DCE). After the message is transmitted, the physical connection is cleared until a response to the message is available or a new message is ready for transmission. Circuit-switched PDNs establish and clear calls quickly.

DATEX-L is the West German circuit-switched public data network. It requires an ICAM global network without DCA and is described in 3.6.3.

NORDIC is the X.21 circuit-switched public data network for Denmark, Finland, Norway, and Sweden. It requires an ICAM global network with DCA. ICAM supports two modes of service for NORDIC circuit-switched public data networks--computer to computer and computer to UTS 20X terminal.

When you code your ICAM network definition for NORDIC (computer to computer), you need to describe the public data network and both the local data terminating equipment (LDTE) and remote data terminating equipment (RDTE). ICAM provides the following special macros to do this:

These Macros:	Describe:
PDN	The kind of public data network
LDTE	The attributes of a local data terminating equipment
CPSTB	A table of actions for call progress signals
VLINE	Some facts about the physical communications line to the PDN: where it is attached to your computer and what line protocol is used.
RDTE	The attributes of a remote data terminating equipment
LPORT	The characteristics and end users of the DCA logical port

Table 3-6 provides an order of presentation of macros you should use when you code your circuit-switched public data network.

Figure 3-28 shows two types of circuit-switched PDNs that ICAM supports: DATEX-L and NORDIC (computer to computer).

Table 3-6. Order of Presentation of Macros in a Network Definition for a Circuit-Switched PDN (Computer to Computer)

Macroinstruction Name	Remarks
Description of Local (Non-PDN) Communications	
CCA	Start of network definition
BUFFERS	Specifies system resources
LOCAP1-n	Creates locap files for local users
LINE1	Describes the first local communications line
TERM1-n	Describes the terminal on the first line
LINE n	Describes the last local communications line
TERM1-n	Describes the terminals on the last local line
DISCFIL1-n	Specifies network disk files
PRCS1-n	Specifies local process files
DLIST	Specifies network distribution lists
MPSTART1-n	Specifies start of MPPS statements
Description of Circuit-Switched Environment	
PDN	Start of circuit-switched environment
LDTE1	Defines the attributes of the first local DTE in the network
CPSTB1-n	Defines a table of actions for ICAM if network cannot be established
VLINE1	Describes the physical link that connects this DTE to its DCE
RDTE1	Defines the attributes of the first remote DTE in this network
LPORT1-n	Defines a logical port
LOCAP1-n	Defines any remote DTE programs (locap files)
PRCS1-n	Defines any remote DTE process files
TERM1-n	Defines any remote DTE terminals
LDTE-n	Defines the attributes of the last local DTE in the network
CPSTB1-n	Defines a table of actions for ICAM if network cannot be established
VLINEn	Describes the physical link that connects this DTE to its DCE
RDTE1	Defines the attributes of the first remote DTE in this network
LPORT1-n	Defines a logical port
LOCAP1-n	Defines any remote DTE program (locap files)
TERM1-n	Defines any remote DTE terminals
PRCS1-n	Defines any remote DTE process files
ENDCCA	Identifies end of ICAM network definition

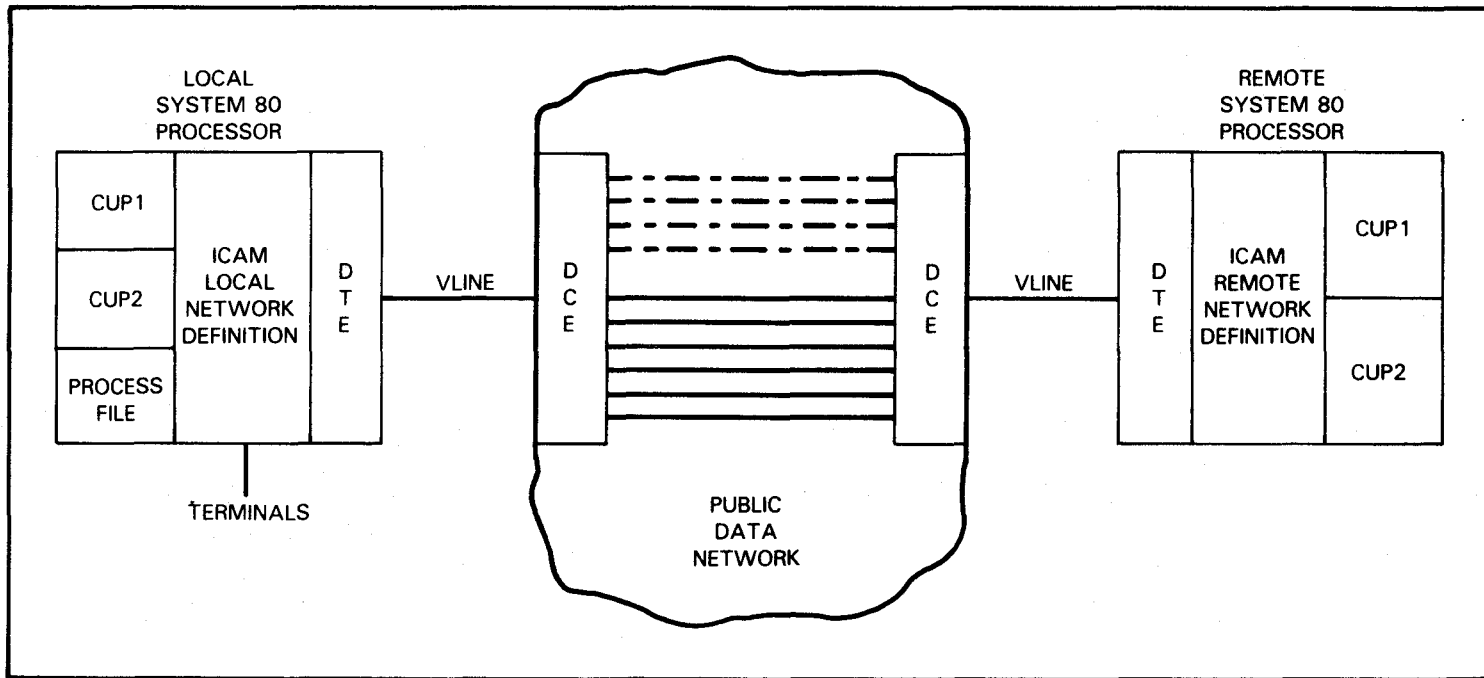

Figure 3-28. Typical DATEX-L NORDIC Circuit-Switched PDN Environment (Computer to Computer)

Figure 3-29 shows the coding for the 2-node NORDIC circuit-switched public data network environment shown in Figure 3-28. Figure 3-30 shows the network definition for the local node(S), and Figure 3-31 shows the network definition for the remote node (T). Both nodes consist of System 80 computer systems.

The first part of each network definition from CCA to PDN defines the network and describes the resources icam needs to support communications at the local node. This includes all locally-connected terminals and locap files to support your programs. This part of the network description is much the same as one you might specify to support any global network.

The part of the network definition beginning with the PDN macro defines the public data environment for ICAM. The PDN macro first identifies the network by type and name. The LDTE macro starts the definition of the interface between the public data network and the local node (System 80). With the ADDRESS= operand of LDTE, you can include the telephone number of the local node if you wish, but it is not required.

If you define your own call progress signal table with the CPSTB macro, specify the label of the first CPSTB macro as shown in the examples. But, you don't have to define your own call progress signal table; you can accept the default values listed in Table 2-3 that are provided by the system. If you accept the default values, you do not have to include any CPSTB macros in your network, and, therefore, you do not have to specify the label of a CPSTB macro in the LDTE macro.

To complete the definition of the interface between the public data network and the local node, you describe the physical line using the operands of the VLINE macro. You can also define the nodes as primary or secondary with the VLINE operand DEVICE=.

With the RDTE macro, you start defining the remote interface of the network by specifying the calling number (address) of the remote node followed by LPORT macros to specify all of the sessions between local and remote end users. Table 3-7 lists all of the local and remote end users defined in Figure 3-29 and all of the sessions specified.

After defining the local and remote interfaces, the LOCAP, TERM, and PRCS macros are included in each network definition to describe the end users of the remote node.

At the end of each network, storage areas, process (PRCS) and disc (DISCFIL) files, are specified. In Figure 3-30, the process file is included for the two local workstations, TRML and TRMW, and the TRMA terminal on line LNE5. The disk file GVD1 is specified for all standard interface local end users with sessions defined with a remote end user. The disk file TVD1 is specified for sessions using TCI (IMS users). Since the remote node (Figure 3-31) has no need for a process file, only disk files for standard interface (GVD2) and IMS (TVD2) sessions are specified.

1	72
COMMCT	
① TTT1	CCA TYPE=(GBL,,S),GAWAKE=YES,DCA=YES, FEATURES=(OPCOM,SEGMENTS,OUTDELV) X
②	BUFFERS 100,64,5,ARP=35,LINKPAK=(50,80,10),UDUCT=(24,28,3)
③ SL01	LOCAP TYPE=(STDMCP),LOW=GVD1,MEDIUM=GVD1,HIGH=GVD1
TL01	LOCAP TYPE=(TCI),LOW=GVD1,MEDIUM=GVD1,HIGH=GVD1
④ LNE1	LINE DEVICE=(UNISCOPE),LBL=256,TYPE=(2400,SWCH,SYNC)
TRM1	TERM ADDR=(28,51),FEATURES=(U400,1920), X LOW=GVD1,MEDIUM=GVD1,HIGH=GVD1,INPUT=(SL02)
TRM2	TERM ADDR=(28,52),FEATURES=(U400,1920), X LOW=GVD1,MEDIUM=GVD1,HIGH=GVD1,INPUT=(SL02)
TRM3	TERM ADDR=(28,53),FEATURES=(U400,1920), X LOW=GVD1,MEDIUM=GVD1,HIGH=GVD1,INPUT=(SL02)
LNE3	LINE DEVICE=(LWS),INPUT=YES
TRML	TERM FEATURES=(U20),ADDR=(312)
LNE4	LINE DEVICE=(LWS),INPUT=YES
TRMW	TERM FEATURES=(U20),ADDR=(313), X LOW=GVD1,MEDIUM=GVD1,HIGH=GVD1
LNE5	LINE DEVICE=(UNISCOPE),LBL=256,TYPE=(2400,SWCH,SYNC)
TRMA	TERM FEATURES=(U400,1920),INPUT=YES,ADDR=(28,51), X LOW=MAIN,MEDIUM=MAIN,HIGH=MAIN
TRMB	TERM FEATURES=(U400,1920),INPUT=(TL02),ADDR=(28,52), X LOW=GVD1,MEDIUM=GVD1,HIGH=GVD1
TRMC	TERM FEATURES=(U400,1920),INPUT=(TL02),ADDR=(28,53), X LOW=GVD1,MEDIUM=GVD1,HIGH=GVD1
⑤ CSW1	PDN TYPE=CIRCUIT,CARRIER=NORDIC
⑥ LDT1	LDTE CPSTBL=TAB1
⑦ TAB1	CPSTB CPS=03,TBD=60 CPSTB CPS=21,NOR=0,TBR=0 CPSTB CPS=(20,44),NOR=5,TBR=5 CPSTB CPS=61,NOR=(2,10),TBR=(10,60) CPSTB CPS=71,NOR=(,10),TBR=(,1800),END=TAB1
⑧ LNE0	VLINE DEVICE=ABM,TYPE=(9600,X21,SWCH),ID=15
⑨ RDT1	RDTE ADDRESS=1357999,TIMER=5
⑩	LPORT EU1=SL01,EU2=SL02,USERTP=STDMCP,CATP=C,LINE=LNE0, X REMOTE=T,PORT=1,RWNDW=2
	LPORT EU1=TRM1,EU2=SL02,USERTP=STDMCP,CATP=C,LINE=LNE0, X REMOTE=T,PORT=2,RWNDW=2
	LPORT EU1=TRM2,EU2=SL02,USERTP=STDMCP,CATP=C,LINE=LNE0, X REMOTE=T,PORT=3,RWNDW=2
	LPORT EU1=TRM3,EU2=SL02,USERTP=STDMCP,CATP=C,LINE=LNE0, X REMOTE=T,PORT=4,RWNDW=2
	LPORT EU1=TL01,EU2=TL02,USERTP=TCI,CATP=C,LINE=LNE0, X REMOTE=T,PORT=5,RWNDW=2
	LPORT EU1=TRMB,EU2=TL02,USERTP=TCI,CATP=C,LINE=LNE0, X REMOTE=T,PORT=6,RWNDW=2
	LPORT EU1=TRMC,EU2=TL02,USERTP=TCI,CATP=C,LINE=LNE0, X REMOTE=T,PORT=7,RWNDW=2
⑪ SL02	LOCAP TYPE=(STDMCP),LOW=GVD1,MEDIUM=GVD1,HIGH=GVD1,REMOTE=(T)
TL02	LOCAP TYPE=(TCI),LOW=GVD1,MEDIUM=GVD1,HIGH=GVD1,REMOTE=(T)
⑫ PRF1	PRCS LOW=MAIN,MEDIUM=MAIN,HIGH=MAIN
⑬ GVD1	DISCFILE FILEDIV=15
⑭	ENDCCA
	MCP MCPNAME=C8
⑮	CACH=(08,2400,SWITCHED,SYNC) CACH=(09,2400,SWITCHED,SYNC) CACH=(15,9600,X21)
END	

a. Local node (S)

Figure 3-29. Sample ICAM Network Definition for a NORDIC Circuit-Switched PDN (Part 1 of 3)

1	72
COMMCT	
① TTT2	CCA TYPE=(GBL,,T),GAWAKE=YES,DCA=YES, FEATURES=(OPCOM,SEGMENTS,OUTDELV) X
②	BUFFERS 100,64,5,ARP=35,LINKPAK=(50,80,10),UDUCT=(24,28,3)
③ SL02	LOCAP TYPE=(STDMCP),LOW=GVD2,MEDIUM=GVD2,HIGH=GVD2
TL02	LOCAP TYPE=(TCI),LOW=GVD2,MEDIUM=GVD2,HIGH=GVD2
⑤ CSW2	PDN TYPE=CIRCUIT,CARRIER=NORDIC
⑥ LDT2	LDTE CPSTBL=TAB2
⑦ TAB2	CPSTB CPS=03,TBD=60 CPSTB CPS=21,NOR=0,TBR=0 CPSTB CPS=(20,44),NOR=5,TBR=5 CPSTB CPS=61,NOR=(2,10),TBR=(10,60) CPSTB CPS=71,NOR=(,10),TBR=(,1800),END=TAB2
⑧ LNE2	VLINE DEVICE=ABM,TYPE=(9600,X21,SWCH),ID=15 X CMDADDR=3,RSPADDR=1
⑨ RDT2	RDTE ADDRESS=1234567,TIMER=10
⑩	LPORT EU1=SL02,EU2=SL01,USERTP=STDMCP,CATP=C,LINE=LNE2, X REMOTE=S,PORT=1,RWNDW=2 LPORT EU1=SL02,EU2=TRM1,USERTP=STDMCP,CATP=C,LINE=LNE2, X REMOTE=S,PORT=2,RWNDW=2 LPORT EU1=SL02,EU2=TRM2,USERTP=STDMCP,CATP=C,LINE=LNE2, X REMOTE=S,PORT=3,RWNDW=2 LPORT EU1=SL02,EU2=TRM3,USERTP=STDMCP,CATP=C,LINE=LNE2, X REMOTE=S,PORT=4,RWNDW=2 LPORT EU1=TL02,EU2=TL01,USERTP=TCI,CATP=C,LINE=LNE2, X REMOTE=S,PORT=5,RWNDW=2 LPORT EU1=TL02,EU2=TRMB,USERTP=TCI,CATP=C,LINE=LNE2, X REMOTE=S,PORT=6,RWNDW=2 LPORT EU1=TL02,EU2=TRMC,USERTP=TCI,CATP=C,LINE=LNE2, X REMOTE=S,PORT=7,RWNDW=2
⑪ SL01	LOCAP TYPE=(STDMCP),LOW=GVD2,MEDIUM=GVD2,HIGH=GVD2,REMOTE=(S)
TL01	LOCAP TYPE=(TCI),LOW=GVD2,MEDIUM=GVD2,HIGH=GVD2,REMOTE=(S)
TRM1	TERM ADDR=(28,51),FEATURES=(U400,1920),REMOTE=(S), X LOW=GVD2,MEDIUM=GVD2,HIGH=GVD2,INPUT=(SL02)
TRM2	TERM ADDR=(28,52),FEATURES=(U400,1920),REMOTE=(S), X LOW=GVD2,MEDIUM=GVD2,HIGH=GVD2,INPUT=(SL02)
TRM3	TERM ADDR=(28,53),FEATURES=(U400,1920),REMOTE=(S), X LOW=GVD2,MEDIUM=GVD2,HIGH=GVD2,INPUT=(SL02)
TRMB	TERM ADDR=(28,52),FEATURES=(U400,1920),REMOTE=(S), X LOW=GVD2,MEDIUM=GVD2,HIGH=GVD2
TRMC	TERM ADDR=(28,53),FEATURES=(U400,1920),REMOTE=(S), X LOW=GVD2,MEDIUM=GVD2,HIGH=GVD2
⑬ GVD2	DISCFILE FILEDIV=15
TVD2	DISCFILE MSGSIZE=960
⑭	ENDCCA MCP MCPNAME=C8
⑮	CACH=(08,2400,SWITCHED,SYNC) CACH=(15,9600,X21)
END	

b. Remote node (T)

NOTES:

- ① Start of a global network. The network that defines the local node (S) is named TTT1. The network that defines the remote node (T) is named TTT2. GAWAKE and DCA are required for circuit-switched PDNs. Features selected are operator communication, segmented message processing, and ICAM output delivery notice.
- ② 100 64-word network buffers are used with a threshold of 5 network buffers. 35 activity request packets are specified as well as 50 link buffers, 80-words long, with a threshold of 10. User data unit control tables are specified as 24 with a threshold of 3.

Figure 3-29. Sample ICAM Network Definition for a NORDIC Circuit-Switched PDN (Part 2 of 3)

- ③ Two locap files are specified in each network to support user programs. One locap file in each network supports the ICAM standard interface, and one supports the transaction control interface (TCI) for IMS operation. Three priority input queues on disk (GVD1) are defined for each file.
- ④ Only the TTT1 network has terminals connected to it. Some of these terminals are connected in sessions with the remote node as shown in Table 3-7, and some are for local usage only.

Lines LNE1 and LNE5 define their attached terminals as UNISCOPE type with a line buffer length of 256 bytes. Line speed is 2400 baud. The lines are synchronized and are switched (dialup).

The three terminals for each line (LNE1 and LNE5) are all UTS 400, set to display 1920 characters. The ADDR operand specifies the rid and sid for each terminal. Three priority output files on disk (GVD1) are specified for each terminal. The SLO2 locap file is designated to retrieve input messages for the terminals on line LNE1, and the TLO2 locap file is designated to retrieve input messages for the terminals on line LNE5.

TRML and TRMW are connected to lines LNE3 and LNE4, respectively, and are UTS 20 local workstations in the TTT1 network.
- ⑤ The PDN macroinstructions begin the public data network portion of these network definitions. The networks are defined as circuit-switched and the carrier as NORDIC.
- ⑥ The LDTE macroinstructions define the attributes of the data terminal equipment (DTE) local to the network, LDT1 for TTT1 and LDT2 for TTT2. The local calling numbers (ADDRESS=) are not stated because it is not required. By default, neither incoming nor outgoing line identifications are validated, nor are outgoing calls barred. Since CPSTBL= is specified for each network, the specifications for the call progress signals are defined in the CPSTB macroinstructions. If CPSTB is not specified, the default values in Table 2-3 are called.
- ⑦ The CPSTB macroinstructions redefine the specifications for the call progress signals identified in the CPS operands. Refer to the example at the end of 2.4 for a description of the use of the CPSTB macroinstruction.
- ⑧ The VLINE macroinstruction describes the physical link between the System 80 node and the public data network. ABM must be specified for circuit-switched PDNs. The TYPE= operand specifies that the line speed is 9600 baud, the interface is a CCITT X.21, and the line is switched (dialup). The slca line number is 15.
- ⑨ The RDTE macroinstruction in each network definition defines the attributes of the data terminal equipment that is remote to it. ADDRESS= gives the telephone number of the remote node; TIMER= specifies that the line is shut down after a five-second period of no activity.
- ⑩ The LPORT macroinstruction defines the parameters for a session between an end user at the local node and an end user at the remote node. All of the end users specified in the LPORT macroinstructions and the sessions defined are listed in Table 3-7. The ICAM interfaces (USERTP=) are identified as standard for the first four ports and transaction control (IMS) for the rest. Dynamic sessions with error recovery are specified (CATP=C). The VLINE is identified (LNE0), the remote node (T), is identified, the logical ports are given the identifications 1, 2, 3, etc. The port window level (unacknowledged outstanding messages before transmission is stopped) is set at 2.
- ⑪ The remote locap file SLO2 in the local node and the remote locap file SLO1 in the remote node support the ICAM standard interface (STDMCP). Three priority queues are specified on disk for each LOCAP from which messages can be retrieved. The LOCAP macroinstructions TLO2 and TLO1 complete the interface for IMS users.
- ⑫ The PRCS macroinstruction for node S defines a process file PRF1 for temporary storage of messages. Three priority files are established. No process files are specified for the remote node T.
- ⑬ The DISCFIL macroinstructions GVD1 and GVD2 provide the storage space on disk required for the STDMCP users. The percentage of space allocated for the control area is 15. TVD1 and TVD2 provide storage space on disk for IMS (TCI) users.
- ⑭ The network definition is ended.
- ⑮ The CACH statements assigned to LNE1 (08) and LNE5 (09) indicate half duplex lines. The CACH statements assigned to an odd numbered port (15) indicate a full duplex line for VLINE LNE0.

Figure 3-29. Sample ICAM Network Definition for a NORDIC Circuit-Switched PDN (Part 3 of 3)

Table 3-7. End User Sessions for the Sample NORDIC Circuit-Switched PDN

Local End Users (TTT1)				
Macro	Label	Type		
LOCAP	SLO1	User program (STDMCP)		
LOCAP	TLO1	User program (TCI)		
#(LINE	LNE1)			
TERM	TRM1	UTS 400 terminal		
TERM	TRM2	UTS 400 terminal		
TERM	TRM3	UTS 400 terminal		
#(LINE	LNE3)			
*TERM	TRML	UTS 20 local workstation		
#(LINE	LNE4)			
*TERM	TRMW	UTS 20 local workstation		
#(LINE	LNE5)			
*TERM	TRMA	UTS 400 terminal		
TERM	TRMB	UTS 400 terminal		
#TERM	TRMC	UTS 400 terminal		
*PRCS	PRF1	Process file		
Remote End Users (TTT2)				
Macro	Label	Type		
LOCAP	SLO2	User program (STDMCP)		
LOCAP	TLO2	User program (TCI)		
End User Sessions				
Port	End Users			ICAM Interface
	TTT1		TTT2	
1	SLO1	-	SLO2	STDMCP
2	TRM1	-	SLO2	STDMCP
3	TRM2	-	SLO2	STDMCP
4	TRM3	-	SLO2	TCI (IMS)
5	TLO1	-	TLO2	TCI (IMS)
6	TRMB	-	TLO2	TCI (IMS)
7	TRMC	-	TLO2	TCI (IMS)

LEGEND:

- # The LINE macroinstruction is included only to show line/terminal relationships.
- * This local end user is not used in sessions with remote end users.

The third type of circuit-switched public data network ICAM supports is NORDIC (computer to UTS 20X). Figure 3-30 shows a typical environment.

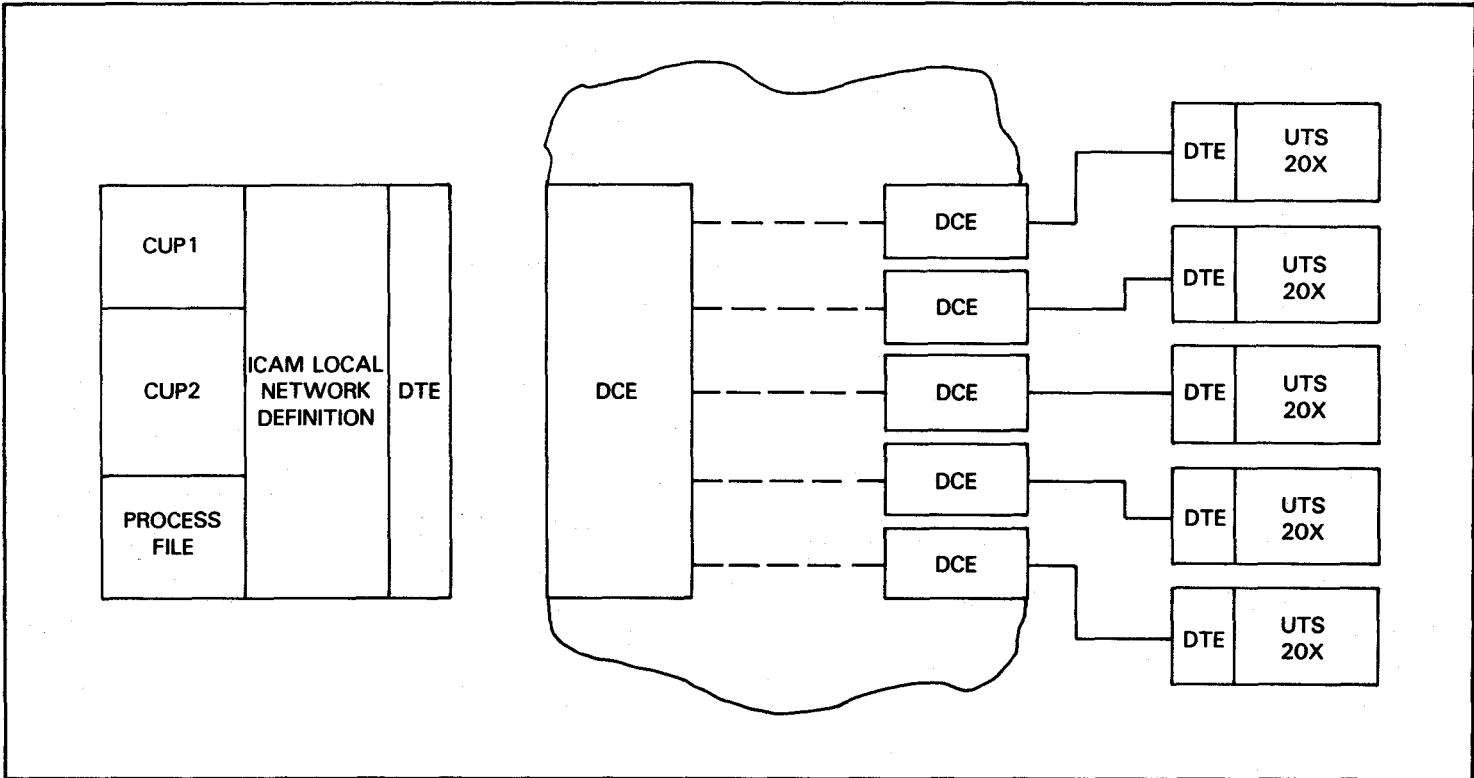

Figure 3-30. Typical NORDIC Circuit-Switched PDN Environment (Computer to UTS 20X Terminal)

When you code your ICAM network definition for NORDIC (computer to UTS 20X terminal), you need to describe the public data network and both the local data terminating equipment (LDTE) and remote data terminating equipment (RDTE). ICAM provides the following special macros to do this:

These Macros:	Describe:
PDN	The kind of public data network
LDTE	The attributes of the local data terminating equipment
CPSTB	A table of actions for call progress signals
LINE	The attributes of the link to the PDN
RDTE	The attributes of the remote data terminating equipment
PGROUP	Specifies the poll group for the UTS 20X terminals
TERM	Describes the terminal attached to the PDN

Table 3-8 provides an order of presentation of macros you should use when you code your circuit-switched public data network (computer to UTS 20X terminal).

Figure 3-31 illustrates a typical computer to UTS 20X NORDIC circuit-switched public data network.

Table 3-8. Order of Presentation for Macros in a Network Definition for a Circuit-Switched PDN (Computer to UTS 20x Terminal)

Non-PDN	Circuit-Switched Environment
CCA	PDN
BUFFERS	LDTE
LOCAP	CPSTB
LINE	LINE
TERM	RDTE
LINE	PGROUP*
TERM	TERM
DISCFILE	RDTE
PRCS	PGROUP*
DLIST	TERM
MPSTART	ENDCCA

* PGROUP defines a polling group for remote workstations and UTS 20X terminals. All of the other macroinstructions are the same as defined in Table 3-6.

```

1                                                                 72
COMMCT                                                            X
X21C      CCA      TYPE=(GBL,,A),GAWAKEYES,DCAYES,
           BUFFERS 50,256,10,ARP=40,STAT=YES,LINKPAK=(45,80) X
           UDUCT=(7,28,3)
OS31      LOCAP    TYPE=(DMI),IAS=(YES,OFF),MODE=SYSTEM
CUP1      LOCAP    TYPE=(STDMCP),LOW=MAIN
CUP2      LOCAP    TYPE=(STDMCP),LOW=MAIN
PDN1      PDN      TYPE=CIRCUIT,CARRIER=NORDIC
LDT1      LDTE     LGROUP=(1,0)
LNE1      LINE     DEVICE=(UTSX),TYPE=(9600,X21,SWCH)
RDT1      RDTE     ADDRESS=123456
           PGROUP  PGID=28
TRM1      TERM     FEATURES=(U20,,,,PRIMARY),ADDR=(28,51), X
           AUX1=(COP,22),INPUT=YES
TRM2      TERM     FEATURES=(20,,,,SECONDARY,ADDR=(28,52), X
           AUX1=(COP,22),INPUT=YES
           ENDCCA
           MCP      MCPNAME=C3
           CACH=(13,9600,SWITCHED,SYNC,X21),LTDE=LDT1
END

```

Figure 3-31. Sample ICAM Network Definition for a Circuit-Switched PDN (Computer to UTS 20X Terminal)

3.6.2. Packet-Switched Public Data Networks

Packet-switched public data networks consist of switching nodes and high speed digital communications trunks as illustrated in Figure 3-32. Under OS/3, ICAM provides the interface between your program in your computer (your computer is considered a data terminal equipment (DTE)) and the public data network's data circuit-terminating equipment (DCE). For packet-switched networks, a DTE can be an OS/3 system or a Universal Terminal System 4020/4040 with workstations.

In a packet-switched environment, all user data is formed into variable length entities called packets. (The 32-byte packet size is not supported.) Appended to each data packet is a header that provides control functions and addressing information to enable the packet to be delivered to the correct destination. All data packets are transferred over virtual circuits. A virtual circuit is a bidirectional association between two data terminal equipments, where data transfer takes the form of packets. Transmission facilities in a public data network are assigned only when they are needed, thus enabling sharing of public data network resources.

You'll notice in Figure 3-32 a series of dashed lines in the public data network. These represent digital communications trunks that connect the various data circuit terminating equipment nodes. Each trunk has the capability to support both permanent and switched virtual circuits.

Two kinds of virtual circuits are used in packet-switched public data networks:

1. Permanent virtual circuits (PVC)
2. Switched virtual circuits (SVC)

A permanent virtual circuit is a permanent association between two data terminal equipments. This is analogous to a point-to-point private line, and requires no call setup or clearing by ICAM.

A switched virtual circuit is a temporary association between two data terminal equipments. When your program requests a session with another end user, ICAM initiates the association by a call request to the public data network. When the association is complete, the public data network reports this to ICAM, which in turn returns an open accept datagram to your program. Your program can now send messages to the remote end user. If the public data network cannot complete the association (the receiving end user cannot or does not want to receive the message, or there is a problem on the public data network), the public data network reports this to ICAM, and ICAM reports to your program in an open reject datagram.

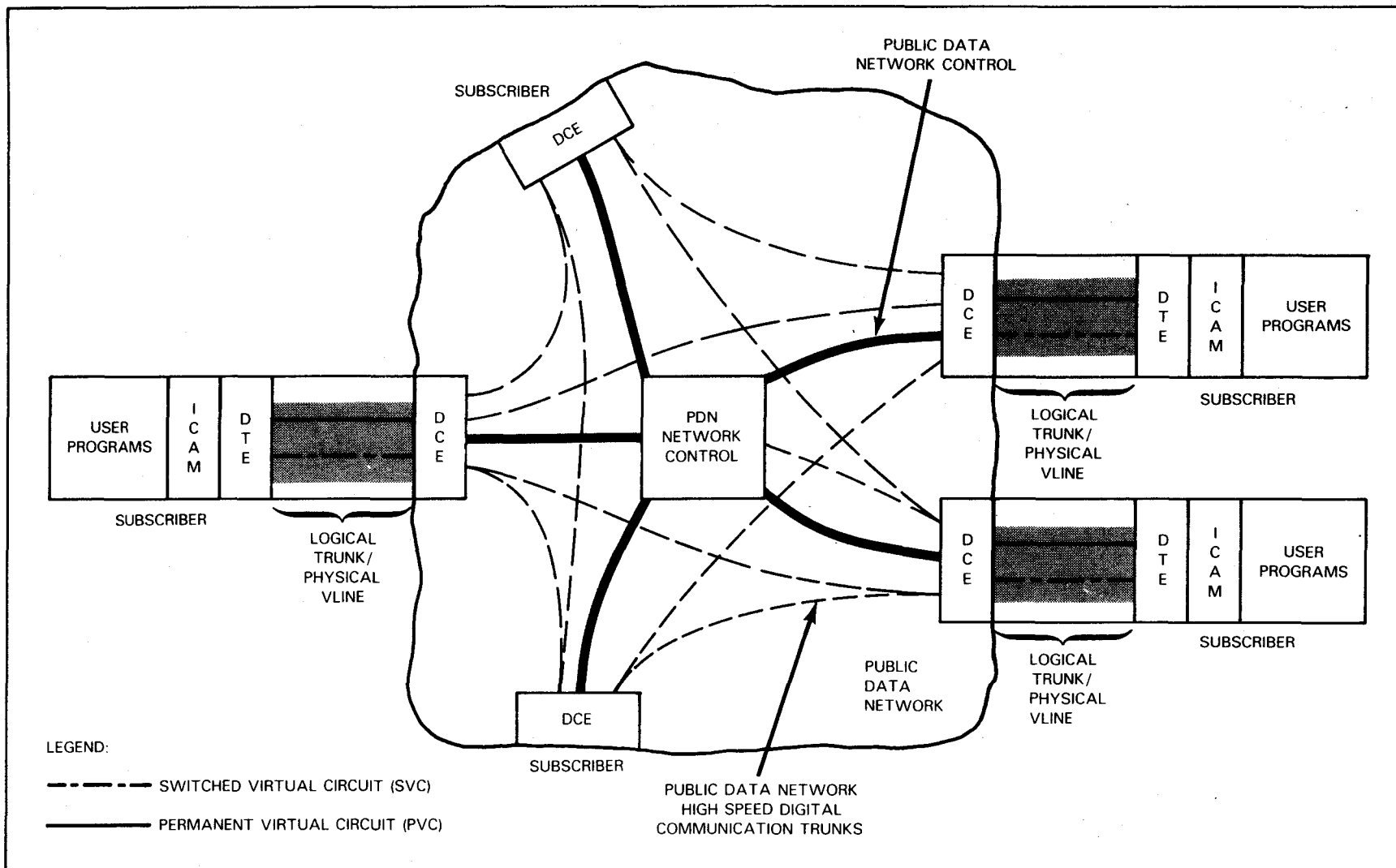

Figure 3-32. Packet-Switched PDN Environment

When you code your ICAM network definition you'll find that most of the network definition is the same as any other global network definition using distributed communications architecture (DCA), except you need to describe the public data network and the facilities that are present in the remote subscriber environment. ICAM provides a few special macros to do this, and they follow the typical organization of a public data network to make it easier to do. For example:

These Macros:	Describe:
PDN	The kind of public data network
TRUNK	How many permanent and switched virtual circuits are used, and how you use them.
VLINE	Some facts about the physical communications line to the public data network: where it is attached to your computer and what line protocol is used.
SUB	Details about the remote subscriber
PVC	Details about permanent virtual circuits
Remote resources	Remote locap files, process files, and terminals in the remote subscriber computer node.
SESSION	For DDX only, details about static sessions used over permanent virtual circuits.

Table 3-9 provides a suggested order of presentation you should use when you code your packet-switched public data network.

Table 3-9. Order of Presentation for ICAM Macros in a Definition for a Packet-Switched PDN

Macroinstruction Name	Remarks
Description of Local (Non-PDN) Communications	
CCA	Begins the network definition
BUFFERS	Specifies system resources
LOCAP _{1-n}	Creates locap files for local users
LINE ₁	Describes the first local communications line
TERM _{1-n}	Describes the terminals on the first line
.	
LINE _n	Describes the last local communications line
TERM _{n-n}	Describes the terminals on this last local line

Table 3-9. Order of Presentation for ICAM Macros in a Definition for a Packet-Switched PDN (cont.)

Macroinstruction Name	Remarks
Description of Local (Non-PDN) Communications	
DISCFIL _{1-n}	Declares any disk files used for disk queuing
JRNFILE _{1-n}	Declares journal files needed
PRCS _{1-n}	Declares any local process files needed
SESSION _{1-n}	Declares any required local static sessions
MPSTART _{1-n}	Describes any local message processing routines
Description of Packet-Switched Environment	
PDN	Begins the definition of a packet-switched public data network. Defines the carrier, its type, and packet size.
TRUNK ₁	Declares the attributes of the first logical link between this data terminal equipment (DTE), and the public data networks data circuit terminating equipment (DCE).
VLINE ₁	Describes the physical link that connects this data terminal equipment and the public data networks data circuit terminating equipment.
VCGROUP _{1-n}	Defines any permanent or switched virtual circuit groups on this trunk. (Used only with DDX and PSS public data networks.)
SUB ₁	Defines the attributes of the first remote subscriber on this trunk.
PVC _{1-n}	Identifies any permanent virtual circuits on this trunk used with the subscriber just defined.
LOCAP _{1-n}	Identifies any remote subscriber programs (locap files)
TERM _{1-n}	Identifies any remote subscriber terminals
PRCS _{1-n}	Identifies any remote subscriber process files
SESSION _{1-n}	Defines static sessions between end users over a permanent virtual circuit. Only one static session per PVC.
SUB _n	Defines the attributes of the last remote subscriber on this trunk.
PVC _{n-n}	Identifies any permanent virtual circuits on this trunk used with the subscriber just defined
LOCAP _{n-n}	Identifies any remote subscriber programs (locap files)
TERM _{n-n}	Identifies any remote subscriber terminals
PRCS _{n-n}	Identifies any remote subscriber process files
SESSION _{1-n}	Defines static sessions between end users over a permanent virtual circuit. Only one static session per PVC.
TRUNK _n	Declares the attributes of the last logical link between this data terminal equipment (DTE), and the public data network's data circuit terminating equipment (DCE).

continued

Table 3-9. Order of Presentation for ICAM Macros in a Definition for a Packet-Switched PDN (cont.)

Macroinstruction Name	Remarks
Description of Packet-Switched Environment	
VLINE _n	Describes the physical link that connects this data terminal equipment and the public data networks data circuit terminating equipment.
VCGROUP _{1-n}	Defines any permanent or switched virtual circuit groups on this trunk. (Used only with DDX and PSS public data networks.)
SUB ₁	Defines the attributes of the first remote subscriber on this trunk.
PVC _{1-n}	Identifies any permanent virtual circuits on this trunk used with the subscriber just defined.
LOCAP _{1-n}	Identifies any remote subscriber programs (locap files)
TERM _{1-n}	Identifies any remote subscriber terminals
PRCS _{1-n}	Identifies any remote subscriber process files
SESSION _{1-n}	Defines static sessions between end users over a permanent virtual circuit. Only one static session per PVC.
SUB _n	Defines the attributes of the last remote subscriber on this trunk
PVC _{1-n}	Identifies any permanent virtual circuits on this trunk used with the subscriber just defined
LOCAP _{1-n}	Identifies any remote subscriber programs (locap files)
TERM _{1-n}	Identifies any remote subscriber terminals
PRCS _{1-n}	Identifies any remote subscriber process files
SESSION _{1-n}	Defines static sessions between end users over a permanent virtual circuit for this trunk. Only one static session per PVC.
ENDCCA	Identifies the end of this network definition.

A 3-Node DDX Packet-Switched Public Data Network

Figure 3-33 illustrates a 3-node DDX packet-switched public data network environment, and Figure 3-34 shows three ICAM network definitions required to support it.

Before we get into discussing how we put together this PDN network, let's talk about what local means and what remote means. Each ICAM network definition describes the ICAM environment where it exists; i.e., in this computer. It also describes the environment in the other computer where the other end user exists. This is the environment of the remote subscriber. Obviously, when we define a network definition for subscriber A, subscribers B, and C are remote subscribers, and when we define a network for subscriber C, subscribers A and B are remote, etc.

Figure 3-34 contains three ICAM network definitions; one for each subscriber (computer node) where ICAM is present. Each ICAM network definition defines the resources required in its own node, the type of public data network link used to connect the subscribers, then each subscriber remote to it.

The first part of each network definition describes the resources needed by ICAM to support local communications. This includes any locally connected terminals, local files to support your programs, and process files you may need. It must also include any resources ICAM needs to support the public data network you are using, such as DCA routines, data unit control tables, and link buffers. Up to this point a network designed to support a public data network is much the same as one you might specify to support any global network.

You begin defining the public data environment by specifying a PDN macro. This macro tells ICAM the kind of public data network you are using, maximum sequencing number, and packet size. Then you describe the communications link that connects this node to the public data network.

Processor A, known as subscriber SUBA, contains two communications links to the DDX public data network called trunks. A trunk is a logical concept used to define a communications link (a logical path) between a local subscriber's data terminal equipment (DTE) and a public data network's data circuit terminating equipment (DCE). You use a TRUNK macro to describe the characteristics of each trunk. Included are its calling address (similar to a telephone number for this trunk), how many permanent virtual circuits it supports, how many input only, output only, and input/output switched virtual circuits it supports and its timeout value.

Notice that trunk TK1 connects subscriber SUBA in processor A to subscriber SUBB in processor B, and that all of the attributes that ICAM needs to know to carry on communications with remote subscriber SUBB are defined following the TRUNK macro labelled TK1. Subscriber SUBA in processor A also connects to remote subscriber SUBC using trunk TK2, and the characteristics ICAM needs to communicate with remote subscriber SUBC follow the trunk TK2 definition. Two separate trunks were used to improve throughput by adding more than one link.

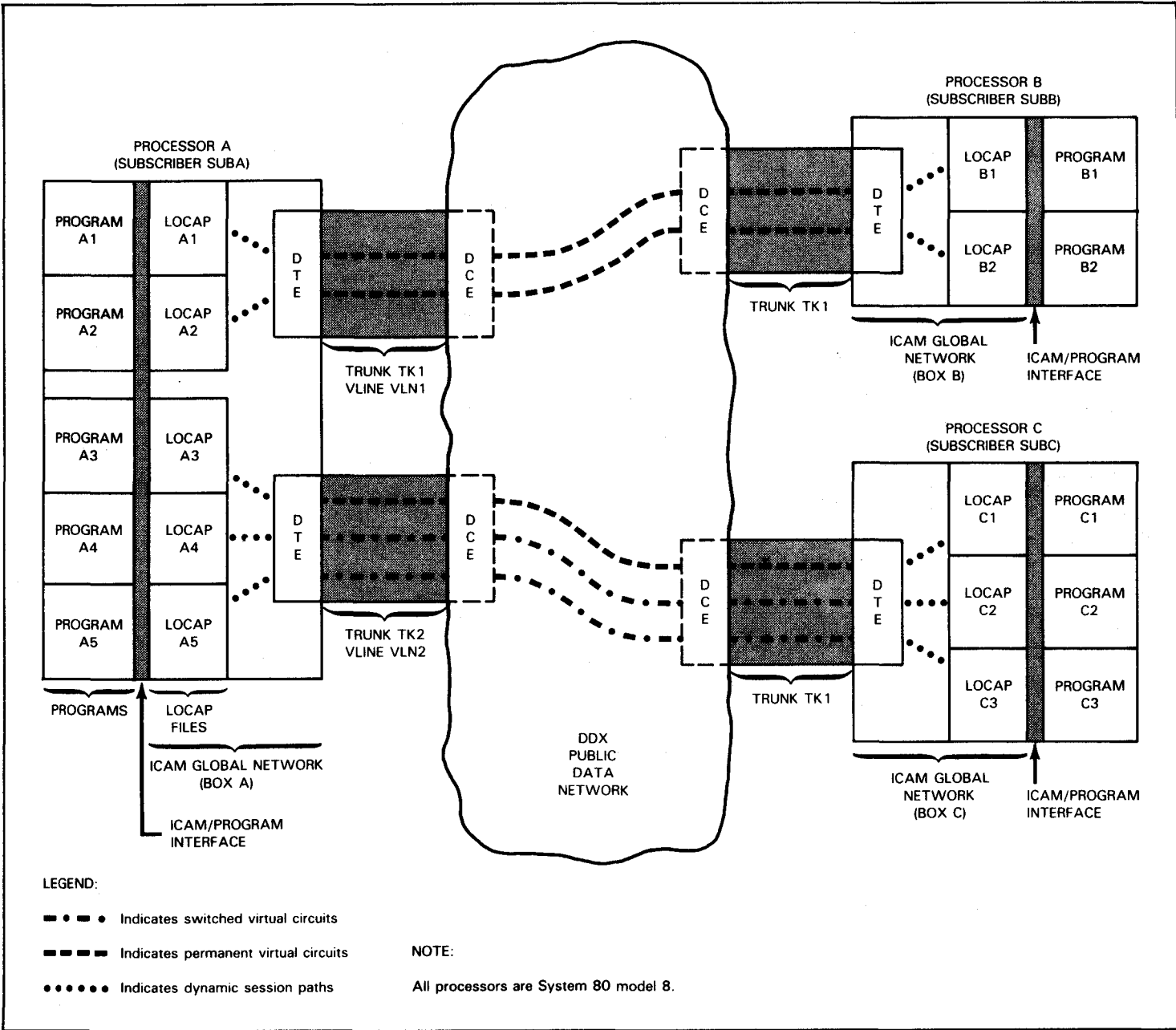

Figure 3-33. Typical DDX Packet-Switched PDN Environment with Three Computer Nodes

VLINE macro VLN1 describes the physical characteristics of trunk TK1, and VLINE macro VLN2 covers the physical characteristics of trunk TK2. They cover such important items as communications adapter location, line speed, and link access procedure used.

You describe each remote subscriber with a SUB macro. The SUB macro tells ICAM the remote subscriber's calling address (similar to a telephone number for the remote trunk), the procedure category to indicate the type of subscriber, whether reverse charges (similar to collect calls) will be accepted from the remote subscriber, if sessions are multiplexed (more than one session per virtual circuit), the closed user group code (if used), and input and output window sizes.

At this point, you describe any permanent virtual circuits that connect this subscriber to the public data network. You define permanent virtual circuits with PVC macros. Permanent virtual circuits are point-to-point, non-switched circuits over which only data, reset, interrupt, and flow control packets can flow. Two permanent virtual circuits connect subscriber SUBA to subscriber SUBB on trunk TK1 and one is used to connect subscriber SUBA to subscriber SUBC on trunk TK2.

In a DDX public data network, 4080 logical channels can be specified. Logical channels are allocated in 16 logical channel groups (0 to 15), and each logical group can have up to 255 logical channels. (You cannot specify logical channel zero (LCN 0).) On trunk TK1 we selected logical channel group 0 and logical channel numbers 1 and 2 for our permanent virtual circuits. On trunk TK2, we also selected logical channel group number 0, and we used logical channel number 1 for our only permanent virtual circuit. Note, that the logical channel group number/logical channel number concept is only used with DDX public data networks.

Two programs reside with subscriber SUBB: program B1 and program B2. You define these remote programs (remote to subscriber SUBA) with LOCAP macros. Notice that the names of the locap files thus defined are specified in the labels of the LOCAP macros and they are marked as being remote to subscriber SUBA by the REMOTE= keyword.

Three programs reside with subscriber SUBC: programs C1, C2, and C3 as identified by the labels of their LOCAP macros. Communication with these programs is by means of trunk TK2.

Two SESSION macros define two static sessions on trunk TK1 between programs A1 and A2 and programs B1 and B2, respectively. These sessions use permanent virtual circuits PCA1 and PCA2. Notice, that although a permanent virtual circuit is defined on trunk TK2 to connect subscriber SUBA and subscriber SUBC, no corresponding SESSION macro is specified. This means that the programs in these nodes communicate using dynamic sessions over the permanent virtual circuit.

Parts B and C of Figure 3-34 provide network definitions for subscribers SUBB and SUBC respectively; and they are quite similar to that shown in part A for subscriber SUBA. They are actually mirror images of the definition for subscriber SUBA viewed from their own computer node.

Defining Your Network

Each network definition is ended with an ENDCCA macro.

To summarize the process of ICAM network definition for a DDX public data network, you must define an ICAM network for each computer node (subscriber) as follows:

Specify:

- DCA=YES in each CCA macro
- all local resources ICAM needs in each computer node
- the public data network you are using in a PDN macro
- TRUNK and VLINE macros for each trunk
- the VCGROUP macro to identify virtual circuit grouping
- the characteristics of the remote subscriber in a SUB macro
- a PVC macro for each permanent virtual circuit
- a LOCAP macro for each remote subscriber program
- a SESSION macro for each static session

1	72
①	BOXA CCA TYPE=(GBL,,NOD1),FEATURES=(OPCOM,DATIME), GAWAKE=YES,DCA=YES X
②	BUFFERS 100,64,0,ARP=35,STAT=YES,UDUCT=(18,28,2), LINKPAK=(100,76,15) X
③	A1 LOCAP TYPE=(STDMCP),LOW=MAIN,PROTYP=XPARENT A2 LOCAP TYPE=(STDMCP),LOW=MAIN,PROTYP=XPARENT A3 LOCAP TYPE=(STDMCP),LOW=MAIN A4 LOCAP TYPE=(STDMCP),LOW=MAIN A5 LOCAP TYPE=(STDMCP),LOW=MAIN
④	PDNA PDN CARRIER=DDX,L3MOD=128,MXCALL=3
⑤	TK1 TRUNK CALLNO=5424986,DATATIM=10
⑥	VLN1 VLINE DEVICE=LAPB,TYPE=(2400),ID=1
⑦	VGA1 VCGROUP LCGN=0,TYPE=PVC,NUMBER=2
⑧	SUBB SUB CALLNO=5425303,CATP=H
⑨	PCA1 PVC LCGN=0,LCN=1,IWS=7,OWS=7 PCA2 PVC LCGN=0,LCN=2,IWS=7,OWS=7
⑩	B1 LOCAP TYPE=(STDMCP),LOW=MAIN,PROTYP=XPARENT,REMOTE=(SUBB,PDN) B2 LOCAP TYPE=(STDMCP),LOW=MAIN,PROTYP=XPARENT,REMOTE=(SUBB,PDN)
⑪	S1 SESSION EU1=A1,EU2=B1,PVC=PCA1 S2 SESSION EU1=A2,EU2=B2,PVC=PCA2
⑫	TK2 TRUNK CALLNO=5425777,DATATIM=10
⑬	VLN2 VLINE DEVICE=LAPB,TYPE=(2400),ID=2
⑭	VGA2 VCGROUP LCGN=0,TYPE=PVC,NUMBER=1 VGA3 VCGROUP LCGN=1,TYPE=IOSVC,NUMBER=2
⑮	SUBC SUB CALLNO=5425662,CATP=F,IWS=7,OWS=7
⑯	PCA3 PVC LCGN=0,LCN=1,IWS=7,OWS=7
⑰	C1 LOCAP TYPE=(STDMCP),LOW=MAIN,REMOTE=(SUBC,PDN) C2 LOCAP TYPE=(STDMCP),LOW=MAIN,REMOTE=(SUBC,PDN) C3 LOCAP TYPE=(STDMCP),LOW=MAIN,REMOTE=(SUBC,PDN)
⑱	ENDCCA

a. Subscriber A's network definition

NOTES:	
①	Start of a global network definition. Operator communications and date and time stamping are required. GAWAKE and DCA must be specified.
②	100 64-word network buffers are used with no threshold. 35 activity request packets. Buffer pool usage statistics required. 18 user data unit control tables required, each 28 words long, and a threshold of 2. 100 link buffers, 76 words long, with a threshold of 15.
③	Five locap files required to support five user programs in this processor. All use the ICAM standard interface. One low priority input queue used on each locap file.
④	Begins public data network portion of network definition. Carrier is DDX, maximum sequencing number is 128, and ICAM will try to establish a call over a switched virtual circuit a maximum of 3 times.

Figure 3-34. ICAM Network Definition Coding to Support a 3-Node Packet-Switched DDX PDN (Part 1 of 5)

- ⑤ Defines trunk TK1, its local data terminal equipment calling address, and the number of seconds before a data packet timeout.
- ⑥ This virtual line uses X.25 LAPB protocol. Line speed is 2400 Baud and the SLCA ID is 1.
- ⑦ Because this is a DDX public data network, virtual circuit groups are required. On this trunk logical channel group number 0, 2 permanent virtual circuits are used: PCA1 and PCA2.
- ⑧ This trunk connects to subscriber SUBB. Subscriber SUBB's DTE calling address is 5425303, and the procedure category is H (i.e., a foreign node, DDX only).
- ⑨ Two permanent virtual circuits are defined on logical channel group 0. Their input and output window sizes are all 7.
- ⑩ Two remote locap files are described. They reside in subscriber SUBB's processor. They each have a low priority queue for input, and communications is by public data network.
- ⑪ Two static sessions are identified: between end users (programs) A1 and B1, and between end users (programs) A2 and B2. Note that these are the names of the locap files previously established in items 3 and 10. Static sessions can only be defined for category H with DDX.
- ⑫ Defines trunk TK2, its local data terminal equipment calling address, and the number of seconds before a data packet timeout.
- ⑬ This virtual line uses X.25 LAPB protocol. Line speed is 2400 Baud and the SLCA ID is 2.
- ⑭ Because this is a DDX public data network, virtual circuit groups are required. Logical channel group number 0 has one permanent virtual circuit, its logical channel number is 1. Logical channel group 1 has two switched virtual circuits with input and output capabilities.
- ⑮ This trunk connects to subscriber SUBC. Subscriber SUBC's DTE address is 5425662, and the procedure category is F. Input and output window sizes are both 7.
- ⑯ A permanent virtual circuit is defined on logical channel group 0, its input and output window sizes are 7.
- ⑰ Three remote locap files are described. They reside in subscriber SUBC's processor. They each have a low priority queue for input, and communications is by public data network.
- ⑱ The network definition is ended.

Figure 3-34. ICAM Network Definition Coding to Support a 3-Node Packet-Switched DDX PDN (Part 2 of 5)

	1	72
①	BOXB CCA TYPE=(GBL,,NOD1),FEATURES=(OPCOM,DATIME), GAWAKE=YES,DCA=YES	X
②	BUFFERS 100,64,0,ARP=35,STAT=YES,UDUCT=(18,28,2), LINKPAK=(100,76,15)	X
③	B1 LOCAP TYPE=(STDMCP),LOW=MAIN,PROTYP=XPARENT B2 LOCAP TYPE=(STDMCP),LOW=MAIN,PROTYP=XPARENT	
④	PDNB PDN CARRIER=DDX,L3MOD=128,MXCALL=3	
⑤	TK1 TRUNK CALLNO=5425303,DATATIM=10	
⑥	VLN1 VLINE DEVICE=LAPB,TYPE=(2400),ID=1	
⑦	VCG1 VCGROUP LCGN=0,TYPE=PVC,NUMBER=2	
⑧	SUBA SUB CALLNO=5424986,CATP=H	
⑨	PCB1 PVC LCGN=0,LCN=1,IWS=7,OWS=7 PCB2 PVC LCGN=0,LCN=2,IWS=7,OWS=7	
⑩	A1 LOCAP TYPE=(STDMCP),LOW=MAIN,REMOTE=(SUBA,PDN) A2 LOCAP TYPE=(STDMCP),LOW=MAIN,REMOTE=(SUBA,PDN)	
⑪	S1 SESSION EU1=B1,EU2=A1,PVC=PCB1 S2 SESSION EU1=B2,EU2=A2,PVC=PCB2	
⑫	ENDCCA	

b. Subscriber B's network definition

NOTES:	
①	Start of a global network definition. Operator communications and date and time stamping are required. GAWAKE and DCA must be specified.
②	100 64-word network buffers are used with no threshold. 35 activity request packets. Buffer pool usage statistics required. 18 user data unit control tables required, each 28 words long, and a threshold of 2. 100 link buffers, 76 words long, with a threshold of 15.
③	Two locap files required to support two user programs in this processor. They use the ICAM standard interface. One low priority input queue is used on each locap file. PROTYP required to support distributed data processing.
④	Begins public data network portion of network definition. Carrier is DDX, level 3 modulus is 128, and ICAM will try to establish a call over a switched virtual circuit a maximum of three times.
⑤	Defines trunk TK1, its local data terminal equipment calling address, and the number of seconds before a data packet timeout.
⑥	This virtual line uses X.25 LAPB protocol. Line speed is 2400 Baud and the SLCA ID is 1.
⑦	Because this is a DDX public data network, virtual circuit groups are required. On this trunk, logical channel group number 0, two permanent virtual circuits are used: PCB1 and PCB2.
⑧	This trunk connects to subscriber SUBA. Subscriber SUBA's DTE calling address is 5424986 (trunk TK1 on SUBA), and the procedure category is H.
⑨	Two permanent virtual circuits are defined on logical channel group 0. Their input and output window sizes are all 7.
⑩	Two remote locap files are described. They reside in subscriber SUBA's processor. They each have a low priority queue for input, and communications is by public data network.

Figure 3-34. ICAM Network Definition Coding to Support a 3-Node Packet-Switched DDX PDN (Part 3 of 5)

Defining Your Network

- ⑪ Two static sessions are identified: between end users (programs) A1 and B1, and between end users (programs) A2 and B2. Note that these are the names of the locap files previously established in items 3 and 10.
- ⑫ The network definition is ended.

1	72
① BOXC CCA TYPE=(GBL,,NOD3),FEATURES=(OPCOM,DATIME), GAWAKE=YES,DCA=YES	X
② BUFFERS 100,64,0,ARP=35,STAT=YES,UDUCT=(18,28,2), LINKPAK=(100,76,15)	X
③ B1 LOCAP TYPE=(STDMCP),LOW=MAIN	
B2 LOCAP TYPE=(STDMCP),LOW=MAIN	
④ PDNC PDN CARRIER=DDX,L3MOD=128,MXCALL=3	
⑤ TK1 TRUNK CALLNO=5425662,DATATIM=10	
⑥ VLN1 VLINE DEVICE=LAPB,TYPE=(2400),ID=1	
⑦ VCG1 VCGROUP LCGN=0,TYPE=PVC,NUMBER=1	
VCG2 VCGROUP LCGN=01,TYPE=IOSVC,NUMBER=2	
⑧ SUBA SUB CALLNO=5425777,CATP=F	
⑨ PCC1 PVC LCGN=0,LCN=1,IWS=7,OWS=7	
⑩ A3 LOCAP TYPE=(STDMCP),LOW=MAIN,REMOTE=(SUBA,PDN)	
A4 LOCAP TYPE=(STDMCP),LOW=MAIN,REMOTE=(SUBA,PDN)	
A5 LOCAP TYPE=(STDMCP),LOW=MAIN,REMOTE=(SUBA,PDN)	
⑪ ENDCCA	

c. Subscriber C's network definition

NOTES:

- ① Start of a global network definition. Operator communications and date and time stamping are required. GAWAKE and DCA must be specified.
- ② 100 64-word network buffers are used with no threshold. 35 activity request packets. Buffer pool usage statistics required. 18 user data unit control tables are required, each 28 words long, and a threshold of 2. 100 link buffers, 76 words long, with a threshold of 15.
- ③ Two locap files required to support two user programs in this processor. They use the ICAM standard interface. One low priority input queue is used on each locap file. PROTYP required to support distributed data processing.
- ④ Begins public data network portion of network definition. Carrier is DDX, level 3 modulus is 128, and ICAM will try to establish a call over a switched virtual circuit a maximum of three times.
- ⑤ Defines trunk TK1, its local data terminal equipment calling address, and the number of seconds before a data packet timeout.
- ⑥ This virtual line uses X.25 LAPB protocol. Line speed is 2400 Baud and the SLCA ID is 1.
- ⑦ Because this is a DDX public data network, virtual circuit groups are required. On this trunk, logical channel group number 0, one permanent virtual circuit is used: PCC1. On logical channel group number 1, two input and output switched virtual circuits are used.

Figure 3-34. ICAM Network Definition Coding to Support a 3-Node Packet-Switched DDX PDN (Part 4 of 5)

- | | |
|----|--|
| 8 | This trunk connects to subscriber SUBA. Subscriber SUBA's DTE calling address is 5425777 (trunk TK1 on SUBA), and the procedure category is F. |
| 9 | One permanent virtual circuit is defined on logical channel group number 0. Input and output window size is 7. |
| 10 | Three remote locap files are described. They reside in subscriber SUBA's processor. They each have a low priority queue for input, and communications is by public data network. |
| 11 | The network definition is ended. |

Figure 3-34. ICAM Network Definition Coding to Support a 3-Node Packet-Switched DDX PDN (Part 5 of 5)

Network Definition to Support a DATAPAC, TRANSPAC, DATEX, or IBERPAC Packet-Switched PDN

Figure 3-35 illustrates a typical 2-node DATAPAC, TRANSPAC, DATEX, or IBERPAC packet-switched public data network, and Figure 3-36 illustrates the coding necessary to generate an ICAM network in each computer node to support it. The coding examples are for a DATAPAC system; however, except for the carrier name specified in the PDN macro, the ICAM network definitions apply to TRANSPAC and DATEX packet-switched public data networks as well.

You will notice that DCA=YES and GAWAKE=YES are specified in the CCA macro because distributed communications architecture and the ICAM GAWAKE facilities are required for all packet-switched public data networks. Six permanent virtual circuits and four switched virtual circuits are defined.

Figure 3-37 shows a typical 3-mode DATAPAC, TRANSPAC, or DATEX packet-switched public data network, with subscriber C as a packet-switched network. We included the entire COMMCT phase of system generation to illustrate the relationship of the system generation CACH statement and the ICAM network definition VLINE macro in regards to the port used for the virtual line. Notice that the ID you specify in the VLINE macro must agree with the SLCA you specify in the CACH statement.

For IBERPAC:

- Eliminate the WS operand in the TRUNK macro.
- Add the IWS and OWS operands to the SUB and PUC macros.
- Specify CALLING=YES in the SUB macro.

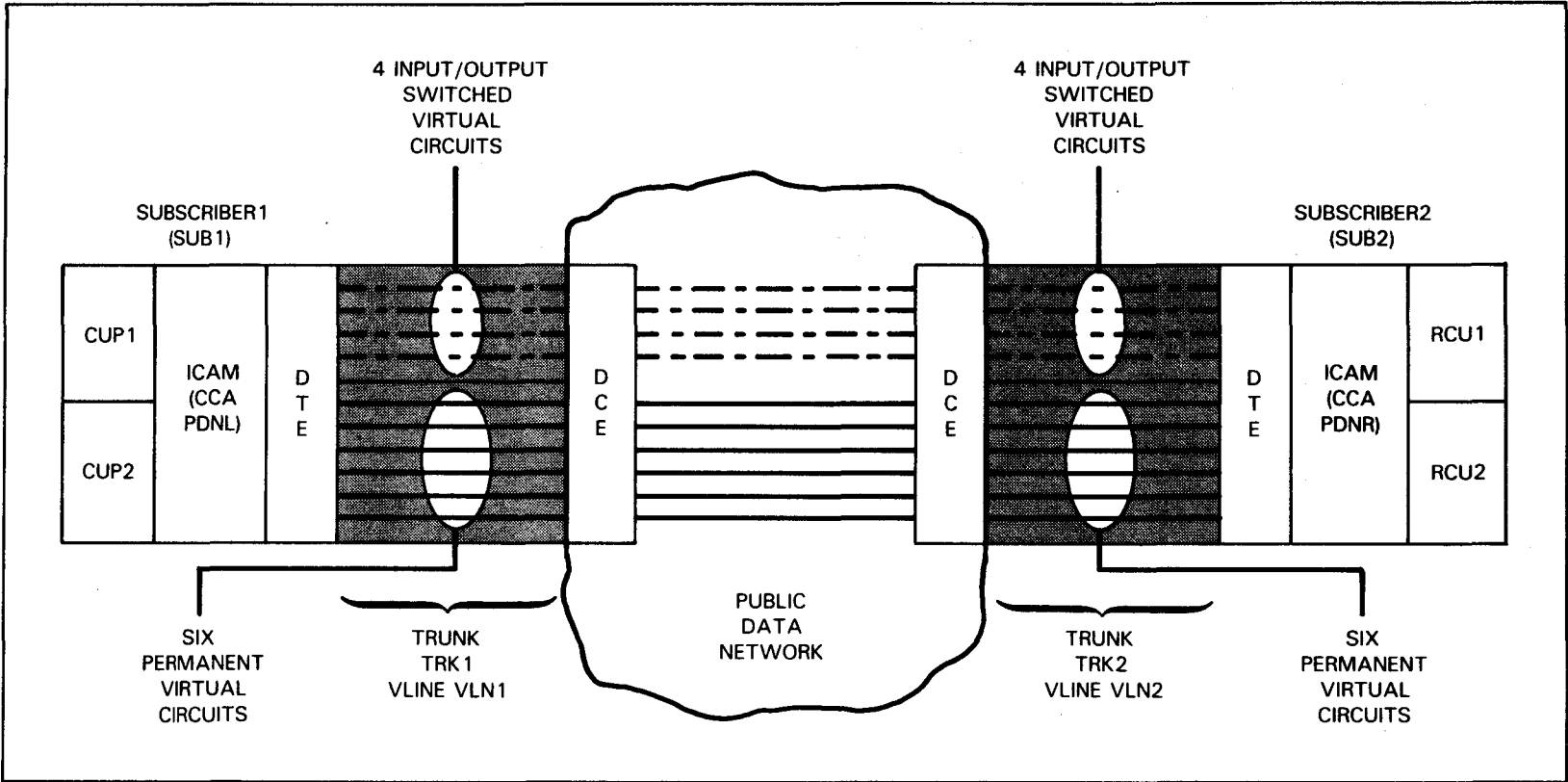

Figure 3-35. Typical 2-Node DATAPAC/TRANSPAC/DATEX/IBERPAC Packet-Switched PDN Environment

```

1      10      16      72
COMMCT
① PDNL      CCA      TYPE=(GBL,,NODA),PASSWORD=POC.TEST,DCA=YES,          X
          FEATURES=(OPCOM,OUTDELV,SEGMENTS,RESTART),                    X
          GAWAKE=YES
②          BUFFERS 20,100,2,ARP=30,STAT=YES,                             X
          UDUCT=(16,28,2),LINKPAK=(50,80,15)
*
*          LOCAL DECLARATIONS
*
③ CUP1      LOCAP TYPE=(STDMCP),LOW=MAIN,MEDIUM=MAIN,HIGH=MAIN
CUP2      LOCAP TYPE=(STDMCP),LOW=MAIN,MEDIUM=MAIN,HIGH=MAIN
*
*          REMOTE DECLARATIONS
*
④ PDN1      PDN      CARRIER=DATAPAC,TYPE=PACKET,L3MOD=8,PKTSIZ=256
⑤ TRK1      TRUNK CALLNO=39999911,PVC=6,IOSVC=4,DATATIM=10,WS=4
⑥ VLN1      VLINE DEVICE=(LAPB),TYPE=9600,ID=05
⑦ SUB1      SUB      CALLNO=39999912,MUX=YES,CATP=G,CUG=01
⑧ PVC1      PVC      LCN=1
PVC2      PVC      LCN=2
PVC3      PVC      LCN=3
PVC4      PVC      LCN=4
PVC5      PVC      LCN=5
PVC6      PVC      LCN=6
⑨ RCU1      LOCAP TYPE=(STDMCP),LOW=MAIN,MEDIUM=MAIN,HIGH=MAIN,          X
          REMOTE=(SUB1,PDN)
RCU2      LOCAP TYPE=(STDMCP),LOW=MAIN,MEDIUM=MAIN,HIGH=MAIN,          X
          REMOTE=(SUB1,PDN)
⑩          ENDCCA
          MCP      MCPNAME=C6
          MCPVOL=REL080
          CACH=(05,9600,FULL,ILA)
⑪ END

```

a. Subscriber I (ICAM network definition PDNL)

Figure 3-36. Sample 2-Node ICAM Network Definition Coding to Support a DATAPAC Packet-Switched PDN (Part 1 of 4)

NOTES:

- ① Start of a global network definition. Features specified are: operator communications, segmented message processing, and warm restart capability. GAWAKE and DCA must be specified for all public data networks.
- ② 20 100-word network buffers are used with a threshold of two network buffers. 30 activity request packets are needed, and buffer pool usage statistics are required. 16 user data unit control tables required, each 28 words long, and a threshold of 2. 50 link buffers, 80 words long, are specified with a threshold of 15.
- ③ Two locap files (CUP1 and CUP2) are specified to support two user programs in this processor. All use the ICAM standard interface. Three priority input queues are used on each locap file.
- ④ The PDN macroinstruction begins public data network portion of this network definition. Carrier is DATAPAC packet switched network; level 3 modulus is 8; and packet size is 256.
- ⑤ Defines trunk TK1, its local subscriber data terminal equipment calling address, and the number of seconds before a data packet timeout (10 seconds). There are six permanent virtual circuits on this trunk and four switched virtual circuits with input/output capability. The level 3 window size is 4.
- ⑥ All packet-switched public data networks use LAPB except DATAPAC which can use LAPA. Line speed is 9600 Baud and the communications adapter for this virtual line is connected to port 5.
- ⑦ This trunk connects to remote subscriber SUB1. Subscriber SUB1's DTE calling address is 39999912, and the procedure category is G. A closed user group code of 01 is specified.
- ⑧ Six permanent virtual circuits are defined on six logical channels. Their input and output window sizes are defaulted to 7.
- ⑨ Two remote locap files (RCU1 and RCU2) are described. The programs they represent reside in the remote processor that supports the ICAM network named PDNR. Each remote locap file has three priority queues for input. The suboperand SUB1 points to the label of the SUB macroinstruction which contains the calling address of the remote subscriber on the public data network.

Note that all communications are carried on by dynamic sessions – thus, no SESSION macroinstructions are used.
- ⑩ The network definition is ended.
- ⑪ This CACH statement specifies that an intelligent line adapter is connected to port 5 to handle the public data network trunk. Note that this is the port identifier specified in the VLINE macroinstruction.

Figure 3-36. Sample 2-Node ICAM Network Definition Coding to Support a DATAPAC Packet-Switched PDN (Part 2 of 4)

```

1          10      16                                     72
COMMCT
① PDNR      CCA   TYPE=(GBL, ,NODA),PASSWORD=POC.TEST,DCA=YES,          X
                FEATURES=(OPCOM,OUTDELV,SEGMENTS,RESTART),          X
                GAWAKE=YES
②          BUFFERS 20,100,2,ARP=30,STAT=YES,                          X
                UDUCT=(16,28,2),LINKPAK=(50,80,15)
*
*          LOCAL DECLARATIONS
*
③ RCU1      LOCAP TYPE=(STDMCP),LOW=MAIN,MEDIUM=MAIN,HIGH=MAIN
RCU2      LOCAP TYPE=(STDMCP),LOW=MAIN,MEDIUM=MAIN,HIGH=MAIN
*
*          REMOTE DECLARATIONS
*
④ PDN2     PDN   CARRIER=DATAPAC,TYPE=PACKET,L3MOD=8,PKTSIZ=256
⑤ TRK2     TRUNK CALLNO=39999912,PVC=6,IOSVC=4,DATATIM=10,WS=4
⑥ VLN2     VLINE DEVICE=(LAPB),TYPE=9600,ID=07
⑦ SUB2     SUB   CALLNO=39999911,MUX=YES,CATP=G,CUG=01
⑧ PVC1     PVC   LCN=1
PVC2     PVC   LCN=2
PVC3     PVC   LCN=3
PVC4     PVC   LCN=4
PVC5     PVC   LCN=5
PVC6     PVC   LCN=6
⑨ CUP1     LOCAP TYPE=(STDMCP),LOW=MAIN,MEDIUM=MAIN,HIGH=MAIN,          X
                REMOTE=(SUB2,PDN)
CUP2     LOCAP TYPE=(STDMCP),LOW=MAIN,MEDIUM=MAIN,HIGH=MAIN,          X
                REMOTE=(SUB2,PDN)
⑩          ENDCCA
MCP      MCPNAME=C7
MCPVOL=REL080
⑪          CACH=(07,9600,FULL,ILA)
END

```

b. Subscriber 2 (ICAM network definition PDNR)

Figure 3-36. Sample 2-Node ICAM Network Definition Coding to Support a DATAPAC Packet-Switched PDN (Part 3 of 4)

Defining Your Network

NOTES:

- ① Start of a global network definition. Features specified are: operator communications, segmented message processing, and warm restart capability. GAWAKE and DCA must be specified for all public data networks.
- ② 20 100-word network buffers are used with a threshold of two network buffers. 30 activity request packets are needed, and buffer pool usage statistics are required. 16 user data unit control tables required, each 28 words long, and a threshold of 2. 50 link buffers, 80 words long, are specified with a threshold of 15.
- ③ Two locap files (RCU1 and RCU2) are specified to support two user programs in this processor. All use the ICAM standard interface. Three priority input queues are used on each locap file.
- ④ The PDN macroinstruction begins public data network portion of this network definition. Carrier is DATAPAC packet-switched network; level 3 modulus is 8 and packet size is 256.
- ⑤ Defines trunk TK2, its local subscriber data terminal equipment calling address, and the number of seconds before a data packet timeout (10 seconds). There are six permanent virtual circuits on this trunk and four switched virtual circuits with input/output capability. The level 3 window size is 4.
- ⑥ All packet-switched networks use LAPB protocol. However DATAPAC can use LAPA. Line speed is 9600 Baud and the communications adapter for this virtual line is connected to port 7.
- ⑦ This trunk connects to remote scriber SUB2. Subscriber SUB2's DTE calling address is 39999911, and the procedure category is G. A closed user group code of 01 is specified.
- ⑧ Six permanent virtual circuits are defined on six logical channels. Their input and output window sizes are defaulted to 7.
- ⑨ Two remote locap files (CUP1 and CUP2) are described. The programs they represent reside in the remote processor that supports the ICAM network named PDNL. Each remote locap file has three priority queues for input. The suboperand SUB2 points to the label of the SUB macroinstruction which contains the calling address of the remote subscriber.

Note that all communications are carried on by dynamic sessions - thus, no SESSION macroinstructions are used.
- ⑩ The network definition is ended.
- ⑪ This CACH statement specifies that an intelligent line adapter is connected to port 7 to handle the public data network trunk. Note that this is the port identifier specified in the VLINE macroinstruction.

Figure 3-36. Sample 2-Node ICAM Network Definition Coding to Support a DATAPAC Packet-Switched PDN (Part 4 of 4)

```

1                                                                 72
COMMCT
*
*
① DAT1   CCA   TYPE=(GBL,,NOD1),FEATURES=(OPCOM),GAWAKE=YES,      X
          DCA=YES
②        BUFFERS   100,64,2,ARP=35,STAT=YES,UDUCT=(18,28,2)      X
          LINKPAK=(78,100,15)
*
* LOCAL DECLARATIONS
*
③ A1     LOCAP TYPE=(STDMCP),LOW=MAIN
A2     LOCAP TYPE=(STDMCP),LOW=MAIN
A3     LOCAP TYPE=(STDMCP),LOW=MAIN
④ PDNA  PDN   TYPE=PACKET,CARRIER=DATAPAC,L3MOD=8,PKTSIZ=128
⑤ TRKA  TRUNK CALLNO=5915484,WS=3,PVC=2,IOSVC=2
⑥ VLNA  VLINE ID=8,DEVICE=LAPA
*
* REMOTE DECLARATIONS FOR SUBSCRIBER B
*
⑦ SUBB  SUB   CALLNO=6887849,CATP=G
⑧ VCA1  PVC   LCN=1
⑨ B1    LOCAP TYPE=(STDMCP),LOW=MAIN,REMOTE=(SUBB,PDN)
B2     LOCAP TYPE=(STDMCP),LOW=MAIN,REMOTE=(SUBB,PDN)
*
* REMOTE DECLARATIONS FOR SUBSCRIBER C
⑦ SUBC  SUB   CALLNO=9918868,CATP=G
⑧ VCA2  PVC   LCN=2
⑨ TRM1  TERM  FEATURES=(U20),ADDR=(30,31),REMOTE=(SUBC,PDN),      X
          LOW=MAIN,MEDIUM=MAIN,HIGH=MAIN
⑩        ENDCCA
MCP    MCPNAME=C7
⑪        CACH=(08,9600,FULL,ILA)
END

```

Figure 3-37. Sample 3-Node ICAM Network Definition Coding to Support a DATAPAC Packet-Switched PDN Using a Packet-Switched Terminal (Part 1 of 2)

NOTES:

- ① Start of a global network definition. Feature specified is operator communications. GAWAKE and DCA must be specified for all public data networks.
- ② 100 64-word network buffers are used with a threshold of two network buffers. 35 activity request packets are needed, and buffer pool usage statistics are required. 18 user data unit control tables are required, each 24 words long, and a threshold of 2. 78 link buffers, 100 words long, are specified with a threshold of 15.
- ③ Three locap files (A1, A2, A3) are specified to support three user programs in this processor. All use the ICAM standard interface. One priority input queue is used on each locap file.
- ④ The PDN macroinstruction begins public data network portion of this network definition. Carrier is DATAPAC packet switched network; level 3 modulus is 8; and packet size is 128.
- ⑤ Defines trunk TRKA – its local subscriber data terminal equipment calling address and, by default, the number of seconds before a data packet timeout (10 seconds). There are two permanent virtual circuits on this trunk and two switched virtual circuits with input/output capability. The level 3 window size is 3.
- ⑥ All packet-switched networks use LAPB protocol. However, DATAPAC can use LAPA. Line speed is 9600 Baud, by default, and the SLCA ID is 8.
- ⑦ This trunk connects to remote subscribers SUBB and SUBC. The call number for each subscriber is given, and the procedure category is G.
- ⑧ One permanent virtual circuit is defined for each remote subscriber. Logical channel numbers are assigned.
- ⑨ Two remote locap files, B1 and B2, are described for SUBB. The programs they represent reside in the subscriber B remote processor. Each remote locap file has three priority queues for input. The suboperand SUBB points to the label of the SUB macroinstruction that contains the calling address of remote subscriber B.

The end user for subscriber C is the terminal TRM1. The terminal is a UTS 20W with a display, by default, of 1920 characters. Subscriber C (SUBC) is a UTS 4020 packet-switched cluster controller with the ASCII address (30, 31) of 1. Three priority terminal output queues are defined. Note that all communications are carried on by dynamic sessions – thus, no SESSION macroinstructions are used.
- ⑩ The network definition is ended.
- ⑪ This CACH statement specifies that an intelligent line adapter is connected to port 8 to handle the public data network trunk. Note that this is the SLCA identifier specified in the VLINE macroinstruction.

Figure 3-37. Sample 3-Node ICAM Network Definition Coding to Support a DATAPAC Packet-Switched PDN Using a Packet-Switched Terminal (Part 2 of 2)

3.6.3. DATEX-L Circuit-Switched Public Data Network

DATEX-L is the West German circuit-switched public data network. It requires an ICAM global network without distributed communications architecture (DCA). DATEX-L is the only PDN that does not require DCA. It conforms to the X.21 bis recommendation without test leads. DATEX-L uses unique operands on the ICAM LINE and TERM macros.

Macro	Operand
CCA	TYPE=(GBL,,node) GAWAKE=Optional
LOCAP	TYPE=(STDMCP)
LINE	CIRCSW=(DATEX,n,n)
TERM	DISIN=n DISOUT=n

ICAM supports DATEX-L in both dedicated and global networks as shown in the following two figures. Figure 3-38 shows a dedicated network and Figure 3-39 shows a global network supporting DATEX-L communications lines. The figures are not annotated because communications lines connected to a DATEX-L public data network are defined like regular non-PDN communications lines, with the following exceptions:

- DATEX-L uses UNISCOPE protocol, therefore, you must specify **DEVICE=UNISCOPE** in the LINE macro for the line that connects to the DATEX-L public data network.
- The CIRCSW operand in the LINE macro identifies the line that is connected to the DATEX-L circuit-switched public data network. You also use it to specify the number of 2-way simultaneous links (full duplex) required and how many input-only links are required.
- Automatic dialing is always required. A special dialing feature is required as described in the *ICAM Technical Overview (UP-9744)*. The DIALER operand specifies the location of the automatic dialer.
- The CALL operand on the TERM macro specifies the "telephone" number ICAM uses to connect to the circuit-switched public data network. Normally, you specify a telephone number in the LINE macro, however, for DATEX-L, you must specify it in the TERM macro.
- DATEX-L requires special UTS 400 terminals. These are available by a request for product quotation (RPQ).

```

1                                                                 72
-----
DATX   CCA   TYPE=(STDMCP),FEATURES=(OPCOM)
        BUFFERS 16,64,2,ARP=20
LNE1   LINE  DEVICE=(UNISCOPE),                                X
        TYPE=(9600,SYNC,SWCH,AUTO),                          X
        ID=12,DIALER=(8),INPUT=PRF1,                          X
        CIRCSW=(DATEX,2,0)
TRM1   TERM  FEATURES=(U400,1920),ADDR=(21,51),              X
        HIGH=MAIN,MEDIUM=MAIN,LOW=MAIN,                       X
        CALL=700322,DISIN=5,DISOUT=5
TRM2   TERM  FEATURES=(U400,1920),ADDR=(21,52),              X
        HIGH=MAIN,MEDIUM=MAIN,LOW=MAIN,                       X
        CALL=047145,DISIN=3,DISOUT=3
TRM3   TERM  FEATURES=(U400,1920),ADDR=(21,53),              X
        HIGH=MAIN,MEDIUM=MAIN,LOW=MAIN,                       X
        CALL=7441293,DISIN=10,DISOUT=5
PRF1   PRCS  LOW=MAIN
        ENDCCA

```

Figure 3-38. Sample ICAM Dedicated Network Definition for DATEX-L Circuit-Switched PDN

```

1                                                                 72
-----
DATX   CCA   TYPE=(GBL,,A),FEATURES=(OPCOM)
        BUFFERS 16,64,2,ARP=20
CUP1   LOCAP TYPE=(STDMCP),LOW=MAIN,                          X
        HIGH=MAIN,MEDIUM=MAIN
CUP2   LOCAP TYPE=(STDMCP),LOW=MAIN,                          X
        HIGH=MAIN,MEDIUM=MAIN
LNE1   LINE  DEVICE=(UNISCOPE),                                X
        TYPE=(9600,SYNC,SWCH,AUTO),                          X
        ID=12,DIALER=(8),INPUT=PRF1,                          X
        CIRCSW=(DATEX,1,0)
TRM1   TERM  FEATURES=(U400,1920),ADDR=(21,51),              X
        HIGH=MAIN,MEDIUM=MAIN,LOW=MAIN,                       X
        CALL=700322,DISIN=5,DISOUT=5
TRM2   TERM  FEATURES=(U400,1920),ADDR=(21,52),              X
        HIGH=MAIN,MEDIUM=MAIN,LOW=MAIN,                       X
        CALL=047145,DISIN=3,DISOUT=3
TRM3   TERM  FEATURES=(U400,1920),ADDR=(21,53),              X
        HIGH=MAIN,MEDIUM=MAIN,LOW=MAIN,                       X
        CALL=7441293,DISIN=10,DISOUT=5
PRF1   PRCS  LOW=MAIN
        ENDCCA

```

Figure 3-39. Sample ICAM Global Network Definition for DATEX-L Circuit-Switched PDN

Section 4

Incorporating ICAM Features into Your Communications System

4.1. Introduction

This section describes some of the many features of ICAM and how to incorporate them into your communications system. Useful features are sometimes difficult to use because several areas are involved, and there is no straightforward description to show you what you need to do to incorporate them. The following subsections describe some of the useful features of ICAM and how to incorporate them into your system. Subjects covered include journaling, disk file preparation, incorporating your own translation tables into ICAM, and message formatting on a terminal basis.

4.2. Creating Disk Files

ICAM uses disk files for different purposes, depending on whether you use the standard interface or transaction control interface. You define ICAM disk files with the DISCFILE macro in your network generation.

Basically, ICAM disk files are used to hold messages, thereby reducing the amount of main storage taken up by network buffers. Messages may be held in a disk buffering file or a disk queuing file.

If you use the standard interface, ICAM queues both input and output messages; you can define one or more disk queuing files for this purpose or use main storage queuing.

With a transaction control interface, ICAM queues output messages only; you can define a disk queuing file (or files) or use main storage queuing.

ICAM also requires a disk buffering file with a transaction control interface for input messages under the dedicated network. If the network is global, do not define the DISCFILE macro with the MSGSIZE operand in the network.

Incorporating ICAM Features

If you use the standard interface with either a dedicated or a global network, then you may specify a disk file for queuing of input and output messages. Code the DISCFILE macros FILEDIV operand. You create queues with the LOW, MEDIUM, and HIGH operands of the LINE, TERM, PRCS, and LOCAP macros. The following illustrates the files created:

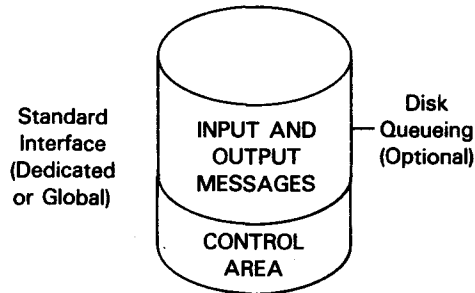

If you use a transaction control interface with a dedicated network, you must specify a disk buffering file for buffering of input messages. Code the DISCFILE macro with the MSGSIZE operand. You may also specify a disk file for queuing of output messages. Code the DISCFILE macro with the FILEDIV operand. You create queues with the LOW, MEDIUM, and HIGH operands of the LINE, TERM, PRCS, and LOCAP macros. The following illustrates the files created:

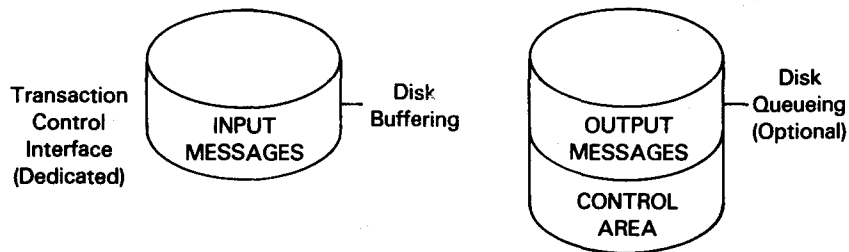

If you use a transaction control interface with a dedicated network, you may specify a disk file for queuing of output messages. Code the DISCFILE macro with the FILEDIV operand. You create queues with the LOW, MEDIUM, and HIGH operands of the LINE, TERM, PRCS, and LOCAP macros. The following illustrates the files created:

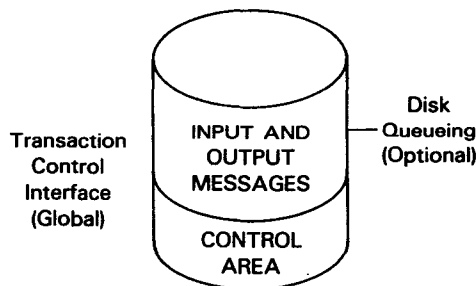

In addition to defining a disk file with a DISCFILE macro, you must allocate the file through OS/3 job control and must assign the file in the job control stream each time you execute your program. If you use a global network, you assign the file in the job control stream for GUST instead of individual user programs. The file name of the LFD statement must match the label on the DISCFILE macro.

When you allocate the file, you include an EXT job control statement on which you identify the file as a system access technique (SAT) file and specify its size in either blocks (256 bytes in length) or cylinders:

```
// EXT ST,C,,BLK,(256,1000)
```

```
// EXT, ST,C,,CYL,3
```

How you figure out the amount of space to allocate depends on whether you are allocating a disk queuing file or a disk buffering file.

The space allocation for a disk queuing file is based on three factors:

1. The average size of your messages
2. The maximum number of messages you expect to have in the file at one time
3. The amount of space you allocate for the control area with the FILEDIV operand of the DISCFILE macro

$$\text{Disk queuing file size} = \left(\text{Average message size} \times \text{Maximum number of messages} \right) + \text{Control area allocation}$$

For example, assume that your average message size is 256 bytes, you expect to have no more than 1000 messages in the file at one time, and you specify FILEDIV=5 on the DISCFILE macro.

$$256 \times 1000 = 256,000 \text{ bytes or } 1000 \text{ 256-byte sectors}$$

(This gives you the size of the message area and is the number you use to figure out the FILEDIV percentage. See 2.8.)

Add 5% or fifty 256-byte sectors for the control area
 Total file size = 1050 256-byte sectors

The EXT job control statement for this file is:

```
// EXT ST,C,,BLK(256,1050)
```

Incorporating ICAM Features

You can also specify the size of the file in cylinders. Cylinder size depends on the type of disk you use. Refer to the appropriate reference manual for your disk subsystem.

Note: You must always allocate at least one cylinder for a disk queuing file.

To allocate space for a disk buffering file, use this formula:

$$\begin{array}{l} \text{Disk buffering} \\ \text{file size} \\ \text{(in 256-byte} \\ \text{blocks)} \end{array} \quad \frac{\frac{m}{n - p + 255}}{256} \times t$$

where:

- m Is the maximum input message size, in bytes.
- n Is the network buffer size, in bytes.
- p Is the size of the message header prefix. See the *size* operand of the BUFFERS macro.
- t Is the number of terminals in the network.

For example, assume your largest input message is 2000 bytes, your network buffer size is 256 bytes, the size of the message header prefix is 80 bytes, and you have 24 terminals in your network.

$$\frac{\frac{2000}{256 - 80} + 255}{256} \times 24 \text{ (rounded up)} = 25$$

The EXT job control statement for this file is:

```
// EXT ST,C,,BLK(256,25)
```

The example shown in Figure 4-1 is a network definition that illustrates the use of both disk buffering and disk queuing files in a network using a transaction control interface. The disk queuing file, TRQUE, is used for both line and terminal output message queuing and for a process file, PRF1. Input messages go to the disk buffering file, TCIFI.

1		72
TNET	CCA T PE=(TCI),FEATURES=(OPCOM,OUTDELV) BUFFERS 200,128,,ARP=35	
LNE1	LINE DEVICE=(UNISCOPE),TYPE=(2400,SWCH,SYNC,CONNECT)	
TRM1	TERM ADDR=(28,51), FEATURES=(U100,960), LOW=TRQUE,MEDIUM=TRQUE,HIGH=MAIN	X X
TRM2	TERM ADDR=(28,52),FEATURES=(U100,960), LOW=TRQUE,MEDIUM=TRQUE,HIGH=MAIN	X
TRM3	TERM ADDR=(29,53),FEATURES=(U100,960), LOW=TRQUE,MEDIUM=TRQUE,HIGH=MAIN	X
TRM4	TERM ADDR=(29,54),FEATURES=(U100,960), LOW=TRQUE,MEDIUM=TRQUE,HIGH=MAIN	X
LNE2	LINE DEVICE=(UNISCOPE), TYPE=(2000,SWCH,SYNC), CALL=4408, LOW=TRQUE,MEDIUM=TRQUE,HIGH=MAIN	X X X
TRM5	TERM ADDR=(28,51), FEATURES=(U400,1920), AUX1=(TP,73)	X X
DLT1	DLIST TRM1,TRM2	
DLT2	DLIST TRM1,TRM2,TRM3,TRM4	
PRF1	PRCS LOW=TRQUE,MEDIUM=TRQUE,HIGH=MAIN	
TCIFI	DISCFILE MSGSIZE=960	
TRQUE	DISCFILE FILEDIV=15 ENDCCA	

Figure 4-1. Transaction Control Interface Network Definition Using Disk Files

The job control stream shown in Figure 4-2 allocates the disk queuing file and the disk buffering file used in the sample network:

```
// JOB ALLOCATE
// DVC 60 // VOL DSP456
// EXT ST,C,,CYL,3
// LBL ICAM.DISK.QUEUE
// LFD TRQUE
// DVC 60 // VOL DSP456
// EXT ST,C,,BLK(256,30)
// LBL ICAM.DISK.BUFFER
// LFD TCIFI
/&
// FIN
```

Figure 4-2. Sample Job Control Stream Showing How to Allocate Disk Queuing and Buffering Files

4.3. Controlling the Message Format to Each of Your Terminals

The message format editing facility (format edit) enables your program to send a message to a terminal and have the format edit routine format it, (that is, control the line width and the number of lines, according to a set of rules you define in an end user profile (EUP) macro. When you define your network, you specify an EUP macro for each terminal where you want editing performed. The EUP macro is described in 2.11.

Editing is based on criteria you define in an EUP macro as follows:

1. An EUP parameter lets you specify a set of fixed (implicit) editing criteria for:
 - DCT 500 and 1000 series terminals
 - Teletypewriter terminals
 - UNISCOPE terminals (64- or 80-character lines)

Or you can specify the editing criteria you want, such as the line width (*lw* suboperand) and, optionally, the number of lines (*lines* suboperand) before a home paper function is sent. If you specify the number of lines, you can also specify that control returns to your program when the required number of lines are sent (RET subparameter).

2. An EDT operand lets you specify an additional editing character you may place in your message text to signal the end of a line.
3. An ETB operand lets you specify a 1- to 3-character sequence that you may place in your message text to indicate the end of a line in addition to the line width and EDT parameters.
4. A CMWO operand is provided to disable the computer message waiting indicator at certain receiving terminals, thus enabling a message display without operator intervention.

Note that if you use the fixed editing criteria for your messages (e.g., EUP=DCT), the only additional editing operand you can specify is the single editing character specified in the EDT operand. However, if you explicitly specify the line width you want, you can specify both the EDT and ETB operand. In this case, actual line width is established according to the first of the three criteria satisfied.

4.4. Journaling

Journaling is the process of having ICAM create records and write them to disk or tape. These records are the raw material the journal utility uses to produce printed reports about your network and, if necessary, produce a restart. A restart provides for the reconstruction of ICAM disk queues should hardware problems develop.

To do journaling, you should be concerned with the following three areas:

- The ICAM network definition macros necessary to incorporate the journaling feature
- The necessary message processing routine macros (MPPS) (a routine you build into your network definition to specify which records you want journaled, the name of the file to receive the records, and the point in time at which the records are to be made).
- The journal utility to produce printed reports or affect a restart

The journal utility produces printed reports that list the text of incoming and outgoing messages, the number of messages sent or received, and the extent to which your network buffers and activity request packet pools were used. Note that the journal utility processes records gathered by ICAM, but the utility operates independently of ICAM (that is, it does not require an ICAM environment). Should ICAM fail due to a disk problem, the journal utility allows you to recover messages queued on disk for transmission. When you request a restart, the journal utility rebuilds the disk message queues. Then perform a warm restart to resume message flow.

To obtain printed reports, three journal utility statements are at your command. Each statement is associated with a report. For example, one statement (BSTAT) gives you a printed report on the extent of network buffer and activity request packet usage. These statements are placed in your job control stream, as is the statement for a cold restart. Details of these statements and examples of their use are found in the *ICAM Utilities Programming Guide* (UP-9748).

Obtaining these printed reports and a restart is the final half of a 2-part process. First, you have ICAM create these records and store them in a journal file.

To create these records, there are certain statements you must include in your network definition. To create one of these five record types - journal records - you also must write a message processing routine. The message processing routine and your network definition are processed as part of the ICAM generation process.

4.4.1. Types of Records

There are five different types of journaling records you can create. These record types and the JRNINIT suboperands of the CCA macro that create them are:

1. **Journal Records** - Each of these records contains the text of a message sent or received, the time and date the journal record was created, and other related information. To incorporate, specify the JOURN suboperand.
2. **ODNR Records** - These records are message dequeuing notices. They are journaled when a message is dequeued for delivery to a terminal or other user program. To incorporate, specify the ODNR suboperand.
3. **Line and Terminal Performance Records** - These records contain the total number of messages sent or received by each terminal and the number of times each terminal was polled. To incorporate, specify the PERF suboperand.
4. **Buffer Statistic Records** - These records contain the number of network buffers used and the frequency they were used. Also listed is your activity request packet size and the frequency the packets were used. To incorporate, specify the STAT suboperand.
5. **Restart Records** - These records contain a copy of each message as it was queued on disk. If ICAM fails due to a disk message queue problem, the journal utility can be used to reconstruct the ICAM disk message queue. Then perform a warm restart to resume message flow. To incorporate, specify the RESTART suboperand.

4.4.2. Building a Journal File

As you write your network definition, you include the macros and operands that tell ICAM to create the records and store them in the journal file. Crucial to your record building process is the JRNFILE macro. This macro defines and names the journal file that stores the records.

Use the following macros and operands in your network definition to create a journal file and the records:

- **CCA Macro**

You must specify the JRNINIT operand. Code it as JRNINIT= followed by the suboperands needed to create the records you want. For example:

```
JRNINIT=(PERF,STAT,JOURN,ODNR,RESTART)
```

When you select STAT, you also must code STAT=YES in the BUFFERS macro.

When you select PERF, you also must code STATS=YES in the LINE macro.

When you select JOURN, you also must code INPUT=mpps-name in either the TERM or LINE macro, and include the JOURN macro in your message processing routine. A journal record is written each time the JOURN macro is executed.

- **BUFFERS Macro**

To create buffer statistic records, specify STAT=YES. This is in addition to the STAT suboperand of the JRNINIT operand of the CCA macro.

- **JRNFILE Macro**

This macro names and specifies the journal file to which the records are written. The name of the journal file is specified by the label you specify for the JRNFILE macro. When you want JOURN records, this label must be an operand of the JOURN macro. The journal file is always a system access technique file on tape or disk that you code in the JRNFILE macro as:

TYPE=(SAT,TAPE)

for a tape file, or

TYPE=(SAT,DISC)

for a disk file.

- **LINE Macro**

You code STATS=YES to create line and terminal performance records. This is in addition to the PERF suboperand of the JRNINIT operand.

To create JOURN records for all terminals on a line, specify the name of your message processing routine in the INPUT operand. Omit the INPUT operand in the LINE macro when you want the JOURN records only for particular terminals or when you do not want any JOURN records. For JOURN records, you also specify the JOURN suboperand of the JRNINIT operand.

- **TERM Macro**

You specify the name of your message processing in the INPUT operand to create JOURN records for a particular terminal. This is in addition to the JOURN suboperand of the JRNINIT operand.

When you want JOURN records for all terminals on a line, omit the INPUT operand in the TERM macro and specify the INPUT operand in the LINE macro.

- **JOURN Macro**

This message processing routine macro allows you to create JOURN records and store them in the journal file you name in the operand of this macro. This file name is the label you assigned to the JRNFILE macro.

For journal records, you also specify the JOURN suboperand of the JRNINIT operand, and include the INPUT operand in either the TERM or LINE macro.

A description of the use of the JOURN macro and message processing routines is provided in the *ICAM MPPS User Guide* (UP-8946).

4.4.3. Sample ICAM Network Definition to Incorporate Journaling

Figure 4-3 is an example of the statements needed in a network definition for journaling.

The shaded portions are the statements that tell ICAM to build records in the journal file. With the JRNINIT operand, we indicate we want line and terminal performance and buffer statistics records.

The STAT=YES operand of the BUFFERS macro indicates we want buffer statistic records.

On both line 1 (LNE1) and line 2 (LNE2), we specified STATS=YES to indicate we want line and terminal performance records for both lines.

The JRNFILE macro names and defines the journal file where the records are stored. We labeled this macro JRN1; it is coded in operand 1 of the JOURN macro of the message processing routines if we decide to produce journal records. We then create the journal file on disk by specifying TYPE=(SAT,DISC) in the JRNFILE macro.

Figure 4-4 is an example of a message processing routine combined with a network definition to create and store records. Included in this example is a message processing routine. You have a choice of where to place the JOURN macros, but the remaining statements, beginning with MPSTART and ending at SENPST, must be included and written in the order presented. Otherwise, your message processing routine does not function and journal records are not produced.

In this example, we placed the JOURN macro among the receive and send groups. Thus, we create journal records for incoming and outgoing messages on the lines and terminals where the INPUT operand is specified.

By placing the JOURN macro after RECEND, a journal record is created after the incoming message is processed. By placing the JOURN macro after SENEND, a journal record is created after the outgoing message is processed. You are not limited to a single journal record. We could create a journal record for outgoing as well as for incoming messages. For more information on the use of the JOURN macro and message processing routines, refer to the *OS/3 ICAM Programming Reference Manual* (UP-9749).

1		72	
NET1	CCA	PASSWORD=CRG,TYPE=(STDMCP), ████████████████████	X
		BUFFERS 20,100,,ARP=24,STAT=YES	
LNE1	LINE	CALL=6461062, DEVICE=(UNISCOPE), TYPE=(2000,SWCH,SYNC), ██████████,	X X X X
		HIGH=MAIN,MEDIUM=DISC1,LOW=DISC2	
TRM1	TERM	ADDR=(29,53), FEATURES=(U100,1024), PINTV=50	X X
TRM2	TERM	ADDR=(29,54), FEATURES=(U100,10), PINTV=50	X X
LNE2	LINE	CALL=6460262, DEVICE=(1004), TYPE=(2400,UNAT,SWCH,SYNC), ID=6, STAT=YES	X X X X
TRM3	TERM	ANSWER=(5,C,PHIL1), FEATURES=(1004), HIGH=MAIN	X X
TRM4	TERM	ANSWER=(5,C,PHIL2), FEATURES=(1004), HIGH=MAIN	X X
PRF1	PRCS	LOW=MAIN	
PRF2	PRCS	LOW=MAIN	
DISC1	DISCFILE	FILEDIV=10,FILESIZE=50	
DISC2	DISCFILE	FILEDIV=10,FILESIZE=50	
		██████████ JRNFILE TYPE=(SAT,DISC)	
		ENDCCA	

Figure 4-3. Sample Network Definition Showing How to Create a Journal File for Buffer and Terminal Statistics

4.4.4. Allocating the Journal File

If you define a journal file in your network definition, you must also allocate the file through OS/3 job control and assign the file in the job control stream each time you execute your program. (If you use a global network, you assign the file in the job control stream for GUST instead of your individual programs.) The file name on the LFD statement must match the label on the JRNFILE macro.

The journal file may be on tape or disk, depending on your TYPE operand specification on the JRNFILE macro.

To allocate a disk journal file, you include an EXT job control statement on which you identify the file as a system access technique (SAT) file and specify its size in either blocks (256 bytes in length) or cylinders:

```
// EXT ST,C,,BLK,(256,4000)
```

```
// EXT ST,C,,CYL,10
```

To determine the amount of space you need for the disk journal file, multiply the average message size by the maximum number of messages you expect to transmit during execution of your program. In the case of a global network, the file should be large enough to contain the messages for all the programs using the global network.

If you use a tape journal file, you do not specify a space allocation, but you can assign as many tape volumes as you need. To assign a single volume tape file, you include a device assignment like the following in your program's job control stream:

```
// DVC 90 // VOL TAPE01 // LBL JRNFILE // LFD JRNFILE
```

Note that any tape journal file definition in a jobstream LBL statement is not mandatory. If you want to specify it, the tape must be initialized with a label previously.

To assign a multivolume tape journal file, you include a device assignment similar to the following in your program's job control stream:

```
// DVC 90 // VOL TAPE01,TAPE02,TAPE03 // LBL JRNFILE,TAPE01  
// LFD JRNFILE
```

4.5. Incorporating Your Own Translation Tables into ICAM

ICAM allows you to incorporate your own (own-code) translation tables into your network. You do this by creating your own translation tables and identifying them in the `LINE` or `TERM` macros by means of the `XLATE` operand.

You construct a translation table by specifying the hexadecimal values you want in ascending order. These values are the result of the hexadecimal values of the characters to be translated.

Translation tables usually are 128 or 256 bytes long (0 to 127 or 0 to 255 positions). However, they can be shorter if need be. Each character to be translated is converted to the hexadecimal value found at the position in the translation table that corresponds to the value of that character.

Example

You construct the following table that begins:

```
00 C5 25 C1 40 E2 C9 E4 0D C4 D9 01 05 C6 C3 D2 etc
```

The character to be translated is 03_{16}
then the character is converted to `C1` (at the fourth location).

If the next character to be translated is $0A_{16}$
then it is translated to `D9` (at the eleventh location).

Notice that the converted values reside at the 4th and 11th locations in the translation table because the `00` is in the 1st location.

Figure 4-5 illustrates how to include your own translation tables in a network definition using the `XLATE` operand.

```

1
72
NET1      CCA
          BUFFERS
1.  L1     LINE   ...   ,XLATE=(INPUTA,1,OUTPUTA,1),...
2.  T1     TERM   ...   ,XLATE=(,OUTPUTB,2),...
3.  T2     TERM   ...   ,XLATE=(INPUTB,2),...
4.  L2     LINE   ...   ,XLATE=(NO),...
5.  T3     TERM   ...   ,XLATE=(YES,YES),...
6.  T4     TERM   ...
7.  L3     LINE   ...   ,XLATE=(,YES),...
8.  T5     TERM   ...   ,XLATE=(,OUTPUTC,3),...
9.  T6     TERM   ...   ,XLATE=(INPUTC,3,NO),...
    INPUTA  DC    XL16'
           .      translation table entries
           .      normally 256 bytes
           .
           DC    XL16'
    INPUTB  DC    XL16'
           .
           .      translation table entries
           .
           DC    XL16'
    INPUTC  DC    XL16'
           .
           .      translation table entries
           .
           DC    XL16'
10. OUTPUTA DC    XL16'
           .
           .      translation table entries
           .
           DC    XL16'
    OUTPUTB DC    XL16'
           .
           .      translation table entries
           .
           DC    XL16'
    OUTPUTC DC    XL16'
           .
           .      translation table entries
           .
           DC    XL16'
          ENDCCA

```

Figure 4-5. Network Definition Showing How to Incorporate User Own-Code Translation Tables (Part 1 of 2)

NOTES:

1. Specifies all terminals on line L1 use translation table INPUTA for input and OUTPUTA for output.
2. Terminal T1 overrides 1 for output.
3. Terminal T2 overrides 1 for input.
4. Shows that line L2 indicates no translation of input is performed for any terminal on that line; output uses a standard table.
5. Shows terminal T3 overrides 4 and calls standard translation tables for both input and output.
6. Specifies terminal T4 uses tables as defined by line L2.
7. Shows that line L3 uses standard input and output translation tables; the standard output table was explicitly called. In this case, the XLATE operand was not needed.
8. Shows terminal T5 calls for a user-supplied output translation table named OUTPUTC for output, but it uses a standard translation table for input.
9. Shows that terminal T6 uses a user-written translation table named INPUTC for input, and no translation is performed on output.
10. Shows how six translation tables were included in a typical network definition.

Figure 4-5. Network Definition Showing How to Incorporate User Own-Code Translation Tables (Part 2 of 2)

4.6. How the Statistics Area Tracks Buffer Pool Usage

When you specify `STAT=YES` for the `BUFFERS` macro, the system creates statistics areas that record usage of the network buffer pool and the activity request packet pool. The format of each area is 12 words of control information followed by one word containing the number of deferred requests and one word containing the number of requests rejected for lack of available network buffers or activity request packets (ARPs). This is followed by the statistics area. The areas are constructed as shown in Figure 4-6.

One full word is devoted to each network buffer or activity request packet in each pool and contains the hexadecimal count of the number remaining in the pool after a network buffer or activity request packet is used.

Both the network buffer pool and activity request packet pool use the same `DSECT`. For dump analysis, the location of the particular pool can be obtained by adding the beginning address of your network to the value of `TN#CARPT` for the activity request packet pool or to the value of `TN#CDTAT` for the network buffer pool.

Figure 4-7 is a sample dump that shows network buffer pool activity. Message traffic in this test system was particularly heavy, as can be seen by the fifteenth position (word 14) in the pool that shows there were no buffers available 616 times (268) 16. Only 137 times during this session were there 39 buffers available, as can be seen by the hexadecimal count of 89 in the fifty-fourth (word 53) position (39 + 14).

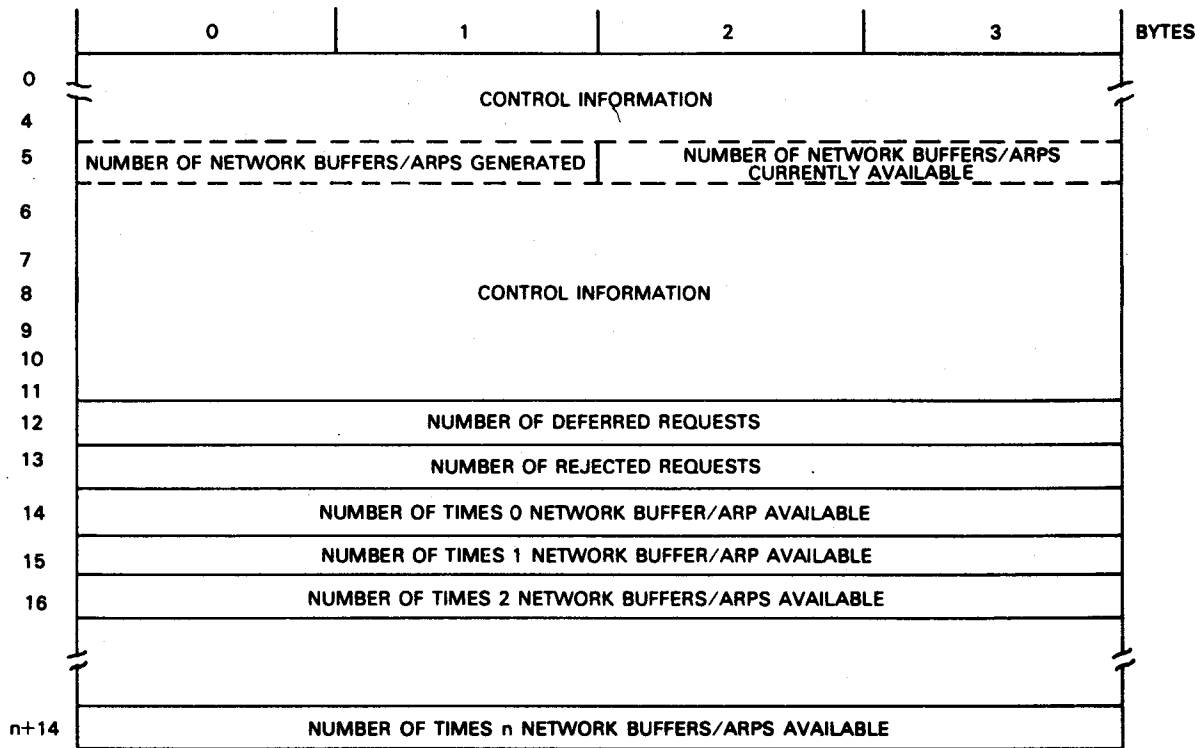

Figure 4-6. Network Buffer/ARP Statistics Area Format

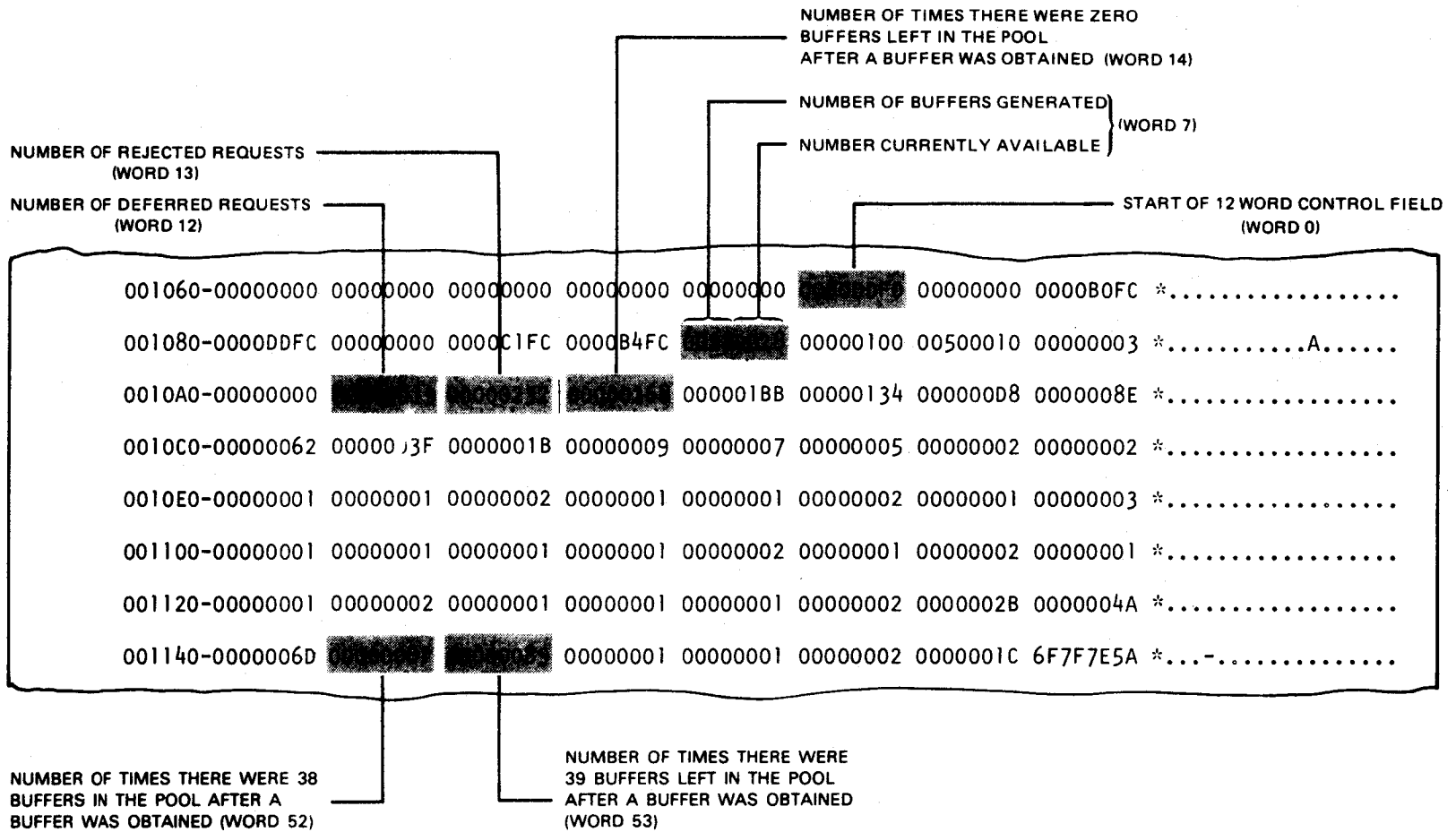

Figure 4-7. Statistics Area for Network Buffers or ARPs



Section 5

System Operations

5.1. Generating ICAM

You create your communications system as part of the system generation (SYSGEN) process outlined in the *OS/3 Installation Guide* (UP-8839). You can have as many as 18 different ICAM symbionts that comprise your communications system; you create each one in a separate system generation.

To generate an ICAM symbiont, you code the parameters in the COMMCT phase of system generation. There are two types of COMMCT parameters: network definition parameters and message control program (MCP) parameters. Both COMMCT parameter types are required to generate your ICAM network. Network definition parameters are described in Section 2. The MCP parameter format is shown in 5.1.1. For a detailed description of MCP parameters, refer to the *OS/3 Installation Guide* (UP-8839).

After the COMMCT parameters are coded, you submit the COMMCT phase to the parameter processor SG\$PARAM. The parameter processor validates the specifications and produces a listing. You then run the prefiled job control stream SG\$COMMK to assemble and link the ICAM symbiont into the \$\$LOD library on your system resident disk volume.

The parameter processor provides default values for operands that are omitted or incorrectly stated. Certain default values are interrelated; that is, the default values for some operands depend on the values you supply for other operands. These default values are indicated in the macro formats by shading or are explained in the text.

You may include more than one network definition in an ICAM symbiont by coding multiple sets of network definition macros in the COMMCT phase. The maximum number of network definitions for the standard, transaction control, and direct data interfaces is four; you may also include one communications physical interface network definition. You can code the CCAMOD parameter in place of network definition macros if you want to include a network definition that is stored in the \$\$SRC library on your system resident volume or the OS/3 release volume. The CCAMOD parameter must be followed by ENDCCA.

To create an ICAM module containing multiple network definitions, your COMMCT phase would look something like this:

```
1 72  
COMMCT Phase name  
    CCA }  
    . } Network definition 1  
    . }  
    ENDCCA }  
    CCA }  
    . } Network definition 2  
    . }  
    ENDCCA }  
    CCAMOD=NET1 }  
    ENDCCA } Network definitions filed in $$$SRC  
    CCAMOD=NET2 }  
    ENDCCA }  
    MCP }  
    . } MCP parameters  
    . }  
END Phase delimiter
```

Figure 5-1 illustrates the coding to generate an ICAM symbiont named M3 containing three network definitions - one for a standard interface, another for a direct data interface, and a third for a communications physical interface. The FEATURES operand of the CCA macro is coded only once; these features become part of ICAM and are available to all networks.

```

1                                                                 72
COMMCT
NET1   CCA   TYPE=(STDMCP),PASSWORD=JHB,                        X
        FEATURES=(OPCOM,OUTDELV)
        BUFFERS 25,100,1,ARP=25
LNE1   LINE  DEVICE=(UNISCOPE),TYPE=(2400,SWCH,SYNC),          X
        CALL=555-2726,INPUT=PRC1
TRM1   TERM  ADDR=(28,51),FEATURES=(U400,1920),                X
        LOW=MAIN,MEDIUM=MAIN,HIGH=MAIN
PRC1   PRCS  LOW=MAIN,MEDIUM=MAIN,HIGH=MAIN
        ENDCCA
NET2   CCA   TYPE=(DDI,3)
        BUFFERS ARP=24
LNE1   LINE  DEVICE=(UNISCOPE),TYPE=(2400,SWCH,SYNC),          X
        CALL=555-2728
TRM1   TERM  ADDR=(28,51),FEATURES=(U400,1920),                X
        AUX1=(TCS,73,74),AUX3=(TCS,75,76)
        ENDCCA
PIOCS  CCA   USERS=2
        ENDCCA
        MCP
        MCPNAME=M9
        MCPVOL=A12345*
        CACH=(08,2400,SWITCHED,SYNC)
        CACH=(12,2400,SWITCHED,SYNC)

END
//FIN

```

* Optional volume serial number of system resident volume (SYSRES).

Figure 5-1. Sample SYSGEN to Generate an ICAM Symbiont

5.1.1. MCP Parameter Format

The MCP parameter format follows the SYSGEN coding rules. This differs from the network definition macro coding rules. For a detailed explanation of each MCP keyword parameter and for guidelines on using the CACH statement, refer to the *OS/3 Installation Guide* (UP-8839). The MCP parameter format follows:

```
MCP [MCPNAME= { C1 } [MCPVOL=vsn]
      { Cn }
      { Mn }]
```

CACH=

The CACH statement has three formats.

Format 1

```
CACH=(nn, network-name,
      line-number, CHAN=nn)
```

Format 2

```
CACH=nn, line-speed [ , { FULL }
                    [ , { half } ]
[ , { AUTODIAL } , nn, EON, p
 [ , { manual } ]
[ , SWITCHED ] [ , SYNC ] [ , { 1LA }
                    [ , { X21 } ]
[ , CHAN= { 2 } ] , LDTE=lcte-name
            { 13 }
            { 15 }
```

Format 3

```
CACH=(nn, DIALER[ , EON])
      [ , CHAN= { 2 }
            { 13 }
            { 15 } ]
[BPOOLEXP=NO]
[FASTLOAD=NO]
```

Format 4 (for DCPCHNL only)

```
CACH=(nn, , DCPCHNL) [ , CHAN=n]
```

5.2. ICAM Initialization and Shutdown

The ICAM load module you create at SYSGEN is a symbiont. That is, when you load it into main storage, it becomes part of the OS/3 supervisor. You must load ICAM before you can execute any communications user programs. If you are using a global network, you load ICAM, then execute GUST before running user programs. ICAM resides in main storage until the last communications user program is terminated (unless you specify the KEEP parameter); with a global network, it remains in main storage until all user programs are completed and GUST is shut down. Then ICAM shuts itself down (unless you specify KEEP).

The KEEP parameter keeps the ICAM symbiont loaded until cancelled by the system operator or if ICAM experiences an unrecoverable error. For example, if you load ICAM by keying in:

```
C5 KEEP
```

ICAM remains loaded after all user programs and GUST are terminated.

5.2.1. Loading an ICAM Symbiont

Always load ICAM in an idle system to avoid main storage fragmentation. Load ICAM from the system console by keying in the operator command:

```
{Cn}Δ[KEEP]
{Mn}
```

where:

Cn OR Mn

Is the ICAM symbiont name specified on the MCPNAME parameter in the COMMCT phase of system generation.

KEEP

Keeps the ICAM symbiont loaded until cancelled by the system operator or ICAM suffers an unrecoverable error.

You can also load ICAM from a job control stream with the statement:

```
// CCA' {Cn} ΔKEEP'
      {Mn}
```

This allows you to load ICAM from a workstation instead of asking the console operator to do it for you, and it also allows you to load ICAM as part of your IMS execution job or as part of a job that executes the global user service task. If you are using embedded data in the GUST job, include a JCL // PAUSE command after the ICAM CC command. This prevents GUST from issuing the NETREQ before ICAM is ready.

You can use the CC job control statement in two ways:

1. In a job control stream that only loads ICAM:

```
// JOB jobname
//ACCA' { Cn } ΔKEEP'
        { Mn }
/&
```

2. In a job control stream that executes your program or, if you are using a global network, in a job control stream that executes the global user service task. The CC job control statement immediately follows the JOB statement.

When ICAM is successfully loaded, the message

```
ICAM 12.0 READY
```

is displayed on the system console.

Notes:

1. *If you load ICAM from a workstation, ICAM messages are still directed to the operator's console.*
2. *If you use embedded data in the GUST job, include a PAUSE command after the CC command. This keeps GUST from issuing the NETREQ before ICAM is ready.*

5.2.2. Loading a Communications User Program

If you use a dedicated network, you can load your communications programs after the ICAM READY message is received. With a global network, you execute GUST, then your communications programs.

You load a communications program the same way as any other user program. That is, you submit a job control stream defining the devices, program name, and any data associated with your program. You must always assign a printer, and if you have requested disk buffering, disk queueing, or journaling in your network definition you must include a device assignment for each file you defined. If you use a global network, you omit the device assignments from this job control stream and include them in the run stream for GUST so they are available to all users of the global network. (See Figure 5-3.)

A job control stream for a communications user program using a dedicated network is illustrated in Figure 5-2. For information on allocating disk queueing and disk buffering files, refer to 4.2; for details on allocating a disk or tape journal file, see 4.4.4.

```

// JOB RECORDS
// DVC 20//LFD PRNTR
// DVC 50 // VOL DSP456
*// EXT ST,C,,CYL,3
// LBL ICAM.DISK.QUEUE // LFD DQFILE
// DVC 50// VOL DSP456
*// EXT ST,C,,BLK(256,100)
// LBL ICAM.DISK.BUFFER // LFD TCIFI
// DVC 51 // VOL DSP50
*// EXT ST,C,,CYL,10
// LBL JRNFILE // LFD JRNFILE
// EXEC USERPROG
/$
    data deck
/*
/&
// FIN

```

* Remove EXT statements after first execution

Figure 5-2. Sample Job Control Stream to Execute User Program

5.2.3. Global User Service Task (GUST) Initialization and Shutdown

Before your program can request attachment to a global network, you must execute the GUST program, ML\$\$GI. You can supply GUST start-up information either through embedded data in the job control stream or by replying to messages from the system console. Figure 5-3 illustrates a sequence of job control streams for executing GUST (without embedded data) and two user programs.

When a virtual line (VLINE) using X.25 protocol is included in your network, the JOB statement for the GUST job must allocate 6000 bytes of main storage. Otherwise, no allocation is necessary on the JOB statement. See Figure 5-3.

All disk and tape files defined in the global network definition with DISCFIELD or JRNFILE macros must be assigned in the GUST job stream, rather than in the job streams for user programs.

This example assigns a previously allocated disk queueing file and a tape journal file. (Refer to 4.2 and 4.4.4 for details on file allocation.) You use the INIT parameter on the LFD statement for the disk queueing file if you want to reinitialize the file; omit this parameter if you want to continue writing to the same file. The EXTEND parameter on the LFD statement for the tape journal file allows you to continue writing to a previously established file. By using the job name GUST, the operator will know that it is the prefiled name needed to do RU jobname at run time.

```
// JOB GUST
// DVC 20 // LFD PRNTR
// OPTION SYSDUMP
// DVC 50 // VOL DSP456 // LBL ICAM.DISK.QUEUE // LFD DQFILE,,INIT
// DVC 90 // VOL TAPE01 // LBL JRNFILE // LFD JRNFILE,,EXTEND
// EXEC ML$$GI
/&
// FIN
// JOB USER1
// EXEC USERA
/&
// FIN
// JOB USER2
// EXEC USERB
/&
// FIN
```

Figure 5-3. Sample Job Control Stream to Execute GUST and User Programs

When GUST is executed, it determines whether to send messages to the system console or to retrieve embedded data from the job control stream to obtain information needed to load your global network. If embedded data is not present in a job stream, the computer operator must respond to each message described in the subsequent text. Embedded data consists of GUST commands in the job control stream formatted the same as required for console messages. Refer to "Initializing GUST" following in this section for data format and Figure 5-4 for an example of GUST with embedded data.

The GUST messages given here are only those pertaining to initialization and shutdown. All GUST messages can be found in the current version of the *System Messages Operations Reference Handbook* (UP-8076).

Initializing GUST

After the ICAM READY message is received on the system console, GUST may be loaded. (When using embedded data, a PAUSE statement before EXEC ML\$\$GI keeps GUST from issuing the NETREQ before ICAM READY. See Figure 5-4.)

If embedded data is used, the information requested by the MC#420 and MC#421 messages must appear in column 1 between the /\$ and /* of the job control stream. (See Figure 5-4.)

If no embedded data is used, the following message is sent by GUST:

```
MC#420 ENTER NETREQ: CCA,PASS,RESTART,LNREQ
```

Meaning

GUST is requesting the name, password, restarts, and line information associated with the global network to be initiated. Virtual lines (VLINES) and remote workstation (RWS) lines are brought up by GUST automatically. Do not specify them as part of the response.

Response

```
cname [ , [password] [ , restart ] [ , { *
      [ ALL [ , Y ]
      [ line-1 [ , line-2 , ... ] [ , * ] } ] ] ] ]
```

where:

cname

Is the name of the global network to be activated. This name must be the same as the label of the CCA macro that begins the network definition for the global network.

password

Is a 1- to 8-character password.

restart

Is N or Y. This determines the type of restart GUST requests for the network. If you specify Y, GUST sets a restart flag to initiate a warm restart, i.e., messages are recovered from existing disk files. If you respond N, normal initialization is begun. That is, new disk files are created if required.

Asterisk specifies that line requests are to be issued only to the lines specified and that message MC#421 is to be issued to obtain the names of additional lines to be activated.

ALL [, Y]

ALL specifies that GUST is to issue line requests for all lines defined in the global network. This is the default situation; if you do not specify *, ALL, or *line-names* in your reply, GUST activates all lines in the network using fatal error recovery procedures (that is, if any line requests are errored, the network will not be activated).

If you specify ALL,Y, line errors are treated as nonfatal errors and the network is brought up.

line-1, line-2, ...

Specifies the local lines for which line requests are to be issued by GUST. The names you specify must be identical to those you specified in the label field of the related LINE macros. Virtual lines (VLINES) and remote workstation (RWS) lines are brought up by GUST automatically. Do not specify them. Since they are brought up automatically before notifying interactive services of the ICAM existence, it is possible for a direct connect remote workstation to output the LOGON message before interactive services is ready to accept the open datagram.

Message

```
MC#421 ENTER LNEREQS: LINE-1,LINE-2,... * OR BLANK
```

Meaning

The operator responded to the MC#420 message (or the previous embedded data command ended) with an asterisk (*); additional lines can be activated by supplying the following:

Response

```
[line-name-1],line-name-2[,...][,*]
```

where:

line-name-1, line-name-2, ...

Are the names of local lines to be activated by means of line requests. GUST issues a LNEREQ statement for each line-name you specify. The line-name must be identical to that specified in the label field of the related LINE macro. Virtual lines (VLINES) and remote workstation (RWS) lines are brought up by GUST automatically. Do not specify them. Since they are brought up automatically before notifying interactive services of the ICAM existence, it is possible for a direct connect remote workstation to output the LOGON message before interactive services is ready to accept the open datagram.

*

Signals the GUST program to repeat this request for more line-names.

If the preceding message is received and no lines are to be activated, you should issue a blank character.

Message

MC#430 GUST ACTIVE FOR CCA nnnn

Meaning

The network you requested is loaded and ready for processing. No response is required. *nnnn* is the name of the global network loaded.

Figure 5-4 shows three different ways to execute GUST from a job stream.

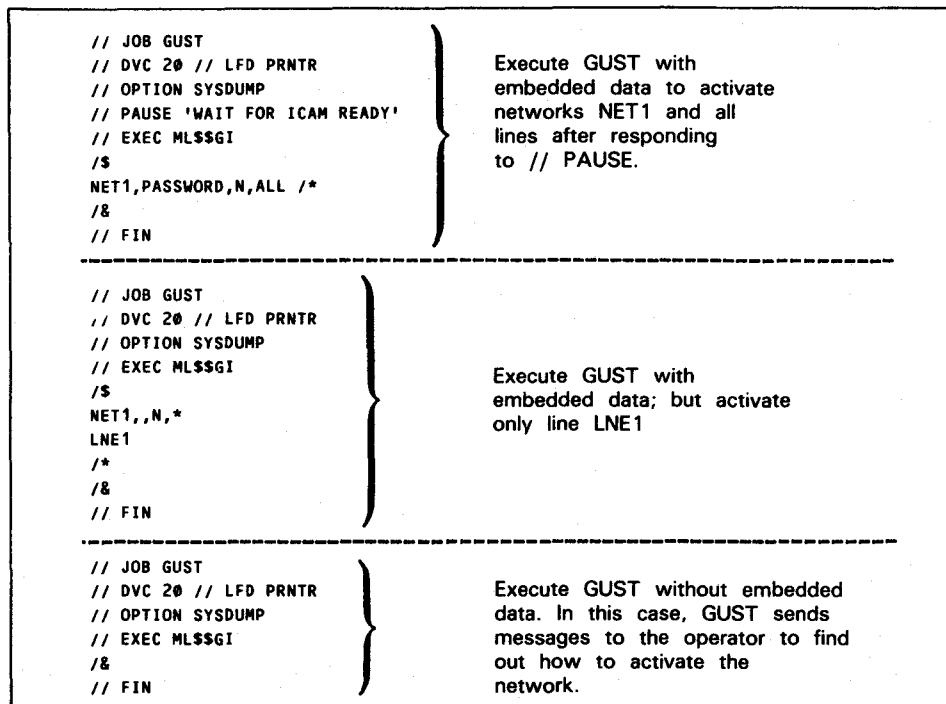

Figure 5-4. Three Ways to Execute GUST in a Job Control Stream with and without Embedded Data Commands

Shutting Down GUST

All ICAM commands are the same for both dedicated and global networks, with one exception. If you issue the following command for a global network, all of your programs are canceled with error code 470. However, all outstanding messages to the system console must be answered before GUST shutdown can complete. See the *System Messages Reference Manual* (UP-8076) for an explanation of all task cancel codes.

Command

```
00Δ { Cn } ΔGUST, network-name  
      { Mn }
```

where:

00 Means this message is destined for the supervisor.

{ Cn }
{ Mn }
Is the name of the ICAM symbiont loaded (C1-C9 or M1-M9).

GU Specifies this command is for GUST.

S Specifies a shutdown is required.

network-name
Is the name of your global network. It must be the same as the label of the CCA macro in your global network definition. If the label is less than four characters, pad it with blanks on the right.

If you enter this command incorrectly, it is ignored, and the following message is displayed:

Message

```
MC#400 GU - - - - - INVALID COMMAND
```

Meaning

The blanks are replaced by whatever type-in you entered. You must reenter the entire command.

If your shutdown request is accepted, the following message is displayed when shutdown processing is complete:

MC#401 GUST SHUTDOWN COMPLETE

To resume communications processing, repeat the entire ICAM start-up procedures. Never cancel the GUST job with the system CANCEL command. If you do so, the CANCEL command will be rejected by GUST and the GUST shutdown command requested.

5.3. System Console Communications

Occasionally, the system console operator must communicate with ICAM to change the communications environment or to advise ICAM of some external event. The console operator does these things via input messages to ICAM entered at the system console. We call these messages ICAM console type-ins, and they may be either unsolicited commands or responses to ICAM messages. For example, a command is issued when the operator puts a line or a terminal down (DO) or reactivates (UP) one. A response is always to a console message from ICAM; e.g., when the console operator responds to an ICAM request to manually dial a telephone number.

The descriptions of the ICAM console type-ins are divided into those used for public data networks and those used for other communication systems. Refer to the *System 80 Operations Guide* (UP-8859) for all console commands and responses.



Section 6

Terminal Operations

This section describes how to configure, start up, and shut down ICAM terminals and workstations. The instructions explain how to establish and disestablish a dynamic session and how to start up and release both local and remote workstations.

6.1. How to Configure Terminals and Workstations for ICAM

Terminals and workstations can be configured in a number of ways:

- A terminal as a terminal
- A local workstation as a workstation (however, this is not an ICAM-specified device)
- A local workstation acting as a terminal
- A terminal acting as a local workstation
- A remote workstation

See Table 6-1 for a summary of system generation and ICAM generation parameters and logon/sign-on procedures.

6.1.1. How to Specify Terminals

You use the LINE, TERM, LDTE, and RDTE network definition macros described in Section 2 to specify terminals used by ICAM. However, in addition to the network definition macros, you must specify certain parameters/operands during various phases of OS/3 system generation.

- During the SUPGEN phase, you must specify the number of communications links (SLCAs) in your system with the COMM parameter.
- During the COMMCT phase, you must specify the MCP parameters described in the *OS/3 Installation Guide* (UP-8839).

Terminal Operations

Table 6-1. Summary of Generation and Logon/Sign-On Procedures for Terminals/Workstations

	Local Workstation	Terminal	Remote Workstation	DCP Terminal
Dynamic Session	Yes	Yes	Yes	Yes
Static Session	Yes	No	No	Auto allocate
Global CCA	Yes	Yes	Yes	Yes
Dedicated CCA	Yes	No	No	No
Logon/Sign-on Procedure	Logon required \$\$\$SON to ICAM CUP	\$\$\$SON to DMI LOCAP LOGON	Logon required \$\$\$SON to ICAM CUP	\$\$\$SON to Telcon \$\$OPEN to LOCAP
\$\$\$SON Entry	System mode from screen 1 Workstation mode from screen 2	Normal entry	System mode from screen 1 Workstation mode from screen 2	Normal entry
TERM Macro AUXn Param	(PRNTR) U40 only	Normal options - req'd on primary/secondary for terminal spooling	Normal options - req'd on secondary for remote spooling	DCP options - req'd on secondary for terminal spooling
TERM Macro FEATURES Param	U20, U40, 1122	U200, U400, U20, U40 Primary/Secondary	U20, U40 Primary/Secondary	U20, U40 Primary/Secondary
PGROUP Macro	No	No	Yes	No
TN#LTYPE	X'90'	X'10'	X'91'	X'B4' - DCP X'B5' - VLINE ABM
LINE Macro/ VLINE/ DCPCHNL	Type=(LWS)	Type=(UNISCOPE)	Type=(RWS)	VLINE DCPCHNL
BUFFERS Macro	Normal	Normal	Add UDUCT LINKPAK	Add UDUCT LINKPAK
LOCAP Macro DMI	No	Yes IAS = (YES,OFF)	Yes Mode = System	Yes IAS=(YES,OFF)
I/OGEN Params	WORKSTATION (Type = 3560,3561) 1122) AUXPRINTER	REWORKSTATION SCREENMEM={ 1 2 }	REWORKSTATION SCREENMEM={ 1 2 }	REWORKSTATION SCREENMEM= { 1 2 }
SUPGEN Param	COMM	COMM	COMM	COMM for VLINE DCPCHNL for DCPCHNL
Comm. Device	No	Yes	Yes	Yes

6.1.2. How to Specify Local Workstations

A local workstation in its native mode does not require ICAM because it is not connected to a communications line. It is directly connected to the system. In system mode, it has access to interactive services for system commands and job processing.

Because local workstations are not ICAM devices, they need only be specified in the system generation. For completeness of the discussion on workstations and terminals, the following description summarizes the things you need to know to specify workstations; however, you should refer to the *OS/3 Installation Guide* (UP-8839) for complete information on each of the SYSGEN parameters referenced.

During the I/OGEN phase of system generation, specify:

- The physical address of the workstation (such as 312, C19)
- The type of local workstation as 3560 (UTS 20D single screen) or 3561 (UTS 40D or 1122 dual screen)
- Whether an auxiliary printer is to be used with the UTS 40D or SVT 1122; it must be specified as AUXPRNTR

For example:

```
I/OGEN
WORKSTATION  ADDR=12
              TYPE=3561
AUXPRINTER  TYPE=0798
```

6.1.3. How to Specify a Local Workstation to Work as a Terminal

If you want to use your local workstation as a terminal to communicate with an ICAM program, you must specify it in your ICAM network definition as:

```
LINE  DEVICE=(LWS)
TERM  FEATURES=(U20), (U40), or (1122)
```

If the auxiliary printer is used on the UTS 40D or SVT 1122, specify it on the TERM macro:

```
TERM  FEATURES=(U40),AUX1=(PRNTR)
      or
TERM  FEATURES=(1122),AUX1=(PRNTR)
```

The UTS 40D and SVT 1122 local workstations have dual-screen capability. You must specify two TERM statements in order for ICAM to use the second screen.

```
LINE1  LINE  DEVICE=(LWS),LBL=1200
C11A   TERM  FEATURES=(1122),ADDR=(C11), . . .
C11B   TERM  FEATURES=(1122),ADDR=(C11), . . .
```

In addition, during the SUPGEN phase of system generation, specify COMM=YES to indicate that the ICAM network is to interface with local workstations. Do not specify this if there is a combination of terminals and workstations in your network.

During the I/OGEN phase of system generation, specify the parameters/operands for a standard local workstation as described in 6.1.2.

During the COMMCT phase, specify the MCP parameters described in the *OS/3 Installation Guide* (UP-8839).

6.1.4. How to Specify ICAM Terminals to Emulate Workstations

If you need to use your ICAM terminals as local workstations, you must specify certain parameters/operands during the various phases of OS/3 system generation (SYSGEN). The following description summarizes the things you need to know; however, you must refer to the current version of the *OS/3 Installation Guide* (UP-8839) for complete information on each of the SYSGEN parameters referenced. ICAM network definition macros and operands are described in this guide.

During the SUPGEN phase, specify the number of communications links (SLCAs) in your system with the COMM parameter.

During the I/OGEN phase, specify the maximum number of communications terminals supported by interactive services with the REMWORKSTATION parameter and SCRENMEM=1.

During the COMMCT phase, specify:

- A CCA macro that specifies a global network: TYPE=(GBL,,node)
- A LOCAP macro for interactive services: TYPE=(DMI), and IAS=(YES,OFF)
- TCTUPD=YES in each ICAM UNISCOPE TERM macro that defines a terminal for use by interactive services
- DEVICE=(UNISCOPE) on the LINE macro
- FEATURES=(U20),(U40),(U200), or (U400) on the TERM macro (UTS 30 terminals are covered under FEATURES=(U40))
- The MCP parameters described in the *OS/3 Installation Guide* (UP-8839)

In addition, make sure your terminals have the field protect feature; otherwise, you will get errors when using them to address interactive products. The *Interactive Services Operating Guide* (UP-9972) outlines how to use terminals as workstations.

6.1.5. How to Specify Remote Workstations

A remote workstation is a special terminal that has the operating characteristics of a local workstation; it is connected to your processor by a communications link to ICAM.

Remote workstations have two modes of operation: workstation mode and system mode. Workstation mode permits communications with user programs using ICAM dynamic sessions. System mode allows the remote workstation to use interactive services, respond to system messages, and control job processing.

If you need to use your remote workstations with interactive services, you must specify certain parameters/operands during the system generation phase. The following description summarizes the things you need to know; however, you must refer to the *OS/3 Installation Guide* (UP-8839) for complete information on each of the SYSGEN parameters referenced. ICAM network definition macros and operands are described in this guide.

During the SUPGEN phase, specify the number of communications links (SLCAs) you have in your system with the COMM parameter.

During the I/OGEN phase, specify:

- The maximum number of communications terminals supported by interactive services. You specify this with the AMOUNT= keyword parameter following the REMWORKSTATION label.
- SCRENMEM parameter on the REMWORKSTATION macro to indicate single- or dual-screen devices.
- REMPRINTER for remote printers connected to remote workstations to allow remote spoolout.

During the COMMCT phase, specify:

- You are using a global network. That is, specify a CCA macro as follows:

```
cca-name CCA TYPE=(GBL,,node)...
```

- UDUCT and LINKPAK operands on the BUFFERS macro.
- DEVICE=(RWS) on the LINE macro.
- The PGROUP macro to define a polling group for the workstation.

- On the TERM macro:
 - FEATURES=(U40 ...) or FEATURES=(U20 ...) specifies the kind of remote workstation. If the workstation has a dual screen, specify the PRIMARY or SECONDARY suboperand of the FEATURES operand.
 - AUXn defines auxiliary devices attached to a terminal for use by ICAM application programs or by the remote spooler. For remote spooler use, specify SECONDARY on the FEATURES operand only.
- The MCP parameters described in the current version of the *OS/3 Installation Guide* (UP-8839).

Note: The TCTUPD operand need not be specified.

In addition, make sure your workstations have the field protect feature; otherwise, you will get errors when using them to address interactive products. The *Interactive Services Operating Guide* (UP-9972) outlines how to use terminals as workstations.

6.2. Establishing a Terminal Dynamic Session

ICAM processes terminal operator requests to dynamically establish or end a communications session. The terminal operator enters sign-on or sign-off commands when it is necessary to communicate with a user program, a process file, another terminal in the network, or to end a session with one of these. Standard terminal dialog is available with global networks that provide dynamic session establishment.

When the command processor receives a valid sign-on command, the following message is sent to the initiating terminal immediately:

```
UNISYS DCA NETWORK, LEVEL n.n NODE ID xxxx
```

where:

n.n
Is the operating system release level.

xxxx
Is the global network node identifier you specified in the TYPE operand of the CCA macro in your network definition.

If the sign-on request is honored, the following message is sent to the initiating terminal; and if the session is between terminals, the two messages are then sent to the requested terminal:

```
SESSION PATH OPEN
```

If the request for session establishment is rejected, the following message is sent to the initiating terminal:

SESSION PATH CLOSED

If a request for sign-off of an established session is issued by another terminal or user program, the following messages are sent to your terminal after disestablishment:

SESSION PATH CLOSED
\$\$\$OFF

If your program aborts an established session, the following message is sent to the affected terminal:

SESSION PATH ABORTED

If an invalid command is entered at a terminal, the following message is returned to the terminal:

INVALID \$\$ COMMAND

6.2.1. Sign-on Command (\$\$SON)

This command enables you to establish a session with a user program, process file, or another terminal.

Format

\$\$SON Δ xxxxyyyy

where:

Δ
Is the required space.

xxxx
Is the logical name of the terminal from which you issue this command (that is, the label of the TERM macro with which you defined the terminal in your network definition).

yyyy
Is the logical name of one of the following:

- a user program (as defined in the label of a LOCAP macro you defined in your network definition)
- a process file (as defined in the label of a PRCS macro)
- another terminal (as defined in the label of a TERM macro)

6.2.2. Sign-off Command (\$\$SOFF)

Enter \$\$SOFF to end a dynamic session.

If your terminal is connected to ICAM by means of a dial line and you issue this command, ICAM holds the telephone connection for 60 seconds after it has ended (disestablished) the session. This enables you to issue a subsequent sign-on command to reestablish another session without redialing.

Format

\$\$SOFF

6.3. How to Log On a Workstation

ICAM supports local workstations, remote workstations, and terminals used as workstations. Local workstations are directly connected by cable to the IOMP channel of the computer to execute interactive service commands, enter jobs, etc. without having ICAM in the system. However, local workstations may be used to communicate with user-written programs or IMS in workstation mode using ICAM. Remote workstations are connected to your computer by communications lines; therefore, ICAM must be present before any communications can begin. These three situations require slightly different startup procedures.

6.3.1. Startup Procedures for a Local Workstation or a Local Workstation Used as a Terminal

When you start up a local workstation, perform the following steps:

- LOGON/Sign-on

You must enter a LOGON command before you use a local workstation, whether you are going to use system mode to interactive services, or workstation mode to one of your programs or IMS. If you are using the workstation as a terminal, you must LOGON and then sign on to the user program locap or other terminal.

The \$\$SON for screen 1 is done from system mode. For UTS 40D and SVT 1122 local workstations, a \$\$SON may be done on screen 2 from workstation (data) mode.

- Allocate the local workstation to ICAM (if necessary)

If you need to communicate with one of your programs or IMS, you must allocate the local workstation to ICAM. ICAM attempts to secure workstation mode when a line request (LNEREQ) is issued for a local workstation as follows:

- In a dedicated network, the using program issues a line request as part of a network request (NETREQ), or explicitly requests the line (LNEREQ).

- In a global network with static sessions, the line request is issued during GUST processing.
- In a global network with dynamic sessions, the line request (LNEREQ) is issued when a sign-on command (\$\$SON) is entered.
- If for some reason, the local workstation is not allocated by one of these methods or the line is marked down, you can force the line request by having the console operator issue an unsolicited console type-in (UP command) to activate the local workstation line.

Since all I/OGEN-specified auxiliary devices are allocated to ICAM when an ICAM applications program attempts to downline load a program to a local workstation, you may want to return these devices to the system when downline loading is complete. If an initiate confidence test (ESC Q) occurs during downline loading, the auxiliary devices should be deallocated; otherwise, the terminal operator should press RESET.

6.3.2. Remote Workstation Startup Procedures

Remote workstations are supported only in global networks and require the use of dynamic sessions. They are essentially communications terminals and always require the use of ICAM.

- During GUST initialization, GUST issues a line request to each remote workstation line.
 - If the remote workstation is on a private line, polling begins immediately. The remote workstation is in workstation mode.
 - If the remote workstation is on a switched line (dial in or dial out), make the phone call when convenient. When the connection is complete, the remote workstation is in workstation mode.
- Because a remote workstation provides you with both system mode and workstation mode, separate concurrent dynamic sessions can be opened.
 - To establish a system mode session, enter a LOGON command in system mode, or press the transmit key (or any function key) to have the LOGON menu displayed. Once the LOGON procedure is complete, use the terminal in the same manner as a local workstation.
 - To establish a workstation mode session with one of your programs or IMS, enter a \$\$SON command from system mode.
 - When the UTS 40 single station or UTS 40 CP/M (with the current prom cartridge) is being used as a UTS 40 remote workstation and auxiliary output is flowing, the terminal must not be placed in system mode. System mode would cause an error condition; the auxiliary output would never complete.

- A remote workstation terminal operator will receive a **SESSION PATH CLOSED** message at the remote workstation when first attempting to establish a system mode session if interactive services has not attached (via **NATTACH**) to ICAM and established itself as an ICAM user. The terminal operator should wait a few seconds before retrying the command (transmit, function key, or system mode request); if resources are available, the expected response will eventually be displayed.
- If a remote workstation goes down, it can be reactivated by the unsolicited type-in **UP** command. However, you must repeat the entire startup procedure (**LOGON**, **\$\$\$SON**).

6.3.3. Startup Procedures for a Terminal Used as a Workstation

ICAM supports terminals as workstations in a global network environment only, and only with dynamic sessions. The following describes how to start up a terminal used as a workstation.

- Normally, a line request is issued during **GUST** processing to activate the communications line. The **GUST** program asks the console operator which lines to activate, and issues line requests based on the response.
 - If the terminal is on a private line, polling begins immediately.
 - If the terminal is on a switched line (dial in or dial out), make the phone call when convenient.
- To establish a dynamic session with interactive services, enter a **\$\$\$SON** command using the demand mode interface (DMI) locap file name as the *to* name. Then:
 - After interactive services displays an OS/3 logon, proceed following the instructions provided by interactive services.
 - After you have signed on to interactive services, you can no longer use the terminal to communicate with IMS or one of your standard interface programs until after you issue a **\$\$\$SOFF** command.
- Interactive services simulates both workstation mode and system mode. To enter system mode, press the message wait key.

6.4. How to Release a Local Workstation from ICAM

You release a workstation from ICAM as follows:

- If your workstation is defined in a dedicated network, execute a NETREL or LNEREL command from your program, or enter a DO command from the operator's console.
- If your workstation is defined in a global network and the workstation is linked to ICAM by a static session, issue a NDETACH macro from your program or enter a DO command from the system console.
- If your workstation is defined in a global network and is linked to ICAM by a dynamic session, issue a \$\$\$OFF command in workstation (data) mode from the workstation, or execute an NDETACH macro from your program, or enter a DO command from the operator's console.

Note: To terminate the ICAM session on a dual-screen device, issue the \$\$\$OFF command in workstation mode from either screen 1 or screen 2.



Appendix A

Relating Telcon and ICAM Networks

A.1. Overview

This appendix assumes that you have already defined your physical network, and that you know where your host computer or computers and DCPs will be located, where your terminals will be located, which models you will use, what types and capacities of communications lines you will use, and so on. All those and other essential aspects of network design are outside the scope of this supplement.

Do not use this appendix exclusively. Use the current version of the *OS 1100/DCP Series, Communications Delivery Software Configuration Guide (UP-9957)* for specifics. Although this manual was not originally designed for use with OS/3, the term CMS 1100 can be used interchangeably with the term OS/3 ICAM.

This appendix contains the following information to help with your Telcon and ICAM generations:

- A list of the related Telcon statements and ICAM macros you need to define and generate a functioning Telcon and ICAM network. It must be able to support DCA Communications Network Software, Communications Delivery Level 2R2M and above.
- A table showing the relationship between the Telcon statements and ICAM macros
- An explanation of how Telcon terminal operation differs from that of OS/3
- Network configuration examples
- General comments and restrictions
- A list of additional documentation required to create the physical configuration for Telcon and OS/3 ICAM networks

A.2. Telcon Network Definition Statements (NDS)

This section lists and explains the Telcon statements that relate to OS/3 ICAM macros. Use the current version of the *OS 1100/DCP Series, Communications Delivery Software Configuration Guide (UP-9957)* for details.

A.2.1. CHANNEL (I/O Interface) Statement

Description

CHANNEL statements define the channel connections between network processors and external devices containing a termination system.

Format

```
name CHANNEL TS=parnt,PPID=(ppid[,bpid]),;  
            [,HBTIM=hbt] [,MODE=(mode,[n1])] [,WINDOW=window] [,STATUS=status]
```

ICAM Related Features

The CHANNEL statement corresponds to the ICAM DCPCHNL macro.

The TS name must match the label on the DCATS statement identified as the host to which this channel is connected.

ICAM does not support any form of resiliency.

A.2.2. DCATS (External Termination System) Statement

Description

DCATS statements define all external devices connected to a Telcon system that contain a termination system or systems, i.e., hosts or DCA terminals.

Format

```
name DCATS PRCSR=prc,;  
            [,RESIL=bdc] [,CRITL=critl] [FLOWCTRL=flowctrl]
```

ICAM Related Features

OS/3 ICAM cannot refer to a full name that exceeds four characters.

OS/3 ICAM does not support any form of resiliency (RESIL, CRITL).

See REMOTE operand of the ICAM LOCAP, LPORT, and TERM macros.

A.2.3. DCPTS (Termination Systems within a DCP) Statement

Description

DCPTS statements define termination systems within network processors.

Format

```
name DCPTS PRCSR=prc
```

ICAM Related Features

OS/3 ICAM cannot refer to a full name that exceeds four characters.

See REMOTE operand of the ICAM LPORT and TERM macros.

A.2.4. DEVICE Statement

Description

DEVICE statements define auxiliary devices, such as printers and paper tape units, that are attached to terminals or clusters.

Format

```
name DEVICE {TERM=parnt },TYPE=dtyp, ADR=(adr1[,adr2])
           {CLSTR=parnt }
```

ICAM Related Features

See AUX*n* operand of the ICAM TERM macro.

A.2.5. SESSN Statement

Description

SESSN statements define sessions between communications system users. They set up the interface between the transport network and the termination system.

Format

```
name SESSN TS1=(tsn,lsch,adcp[,bdcp]),TS2=(tsn,lsch,adcp[,bdcp]);
          [,PROG1=(pfcop,pfcak,csun,tx)];
          [,PROG2=(pfcop,pfcak,csun,tx)];
          [,PRI=pril[,ASPC=aspc,]
```

ICAM Related Features

If the TS1/TS2 *tsn* parameter is defined as the DCATS for the OS/3 host, the *lsch* parameter for that TS1/TS2 must correspond to the PORT operand on the ICAM LPORT macro.

ICAM supports only DTP sessions.

A.2.6. STATION Statement

Description

STATION statements define all UDLC stations associated with a LINE or GROUP.

Format

```
name STATION { LINE=parnt }, ;
              { GROUP=parnt }
              RSHLE=(rshle[,hque]);
              [,MODE=mode][,LSTYP=(lstyp)];
              [,LSA=lsa];
              [,RSA=rsa][,RSIO=rsio];
              [,CFTYP=cftyp][,WINDOW=(swin,ithr)];
              [,GSA=gsa][,DTEID=dteid][,STATUS=status];
              [,TYPECODE=typecode][,REVISION=revision][,SUBNETID=subnetid];
```

ICAM Related Features

The RSHLE field must match the DCATS name associated with the OS/3 host.

The LSA field must match the CMDADDR operand of the ICAM VLINE macro.

The RSA field must match the RSPADDR operand of the ICAM VLINE macro.

A.2.7. TERM Statement

Description

TERM statements define terminals.

Format

```
name TERM { GROUP=parnt }
           { PRCSR=parnt }
           { CLSTR=parnt }
           { SITE=parnt }
```

continued

```

TYPE=(type)
[,DEST=dest] <or> [SESSN=(sname,endno,[sesend])];
[ , { ADR=(rid,sid) } ],[ALOC=aloc];
  { PPID=ppid }
[,BFSZ=(ibs,obs)][,OPTH=opth][,OCRD=ocrd];
[,BELL=bell][,FMT=(rows,cols[,dens])];
[,SBYPS=sbyps][,KATK=katk][,MASTR=mastr];
[,AUTH=auth]; uor> [,AUTH=auth,name];
[,OPDS=opds][,CEDS=ceds][,RECEIVE=recv];
[,MRT=mrt][,DVCN=dvcn][,CDC=cdc][,ECHO=echo];
[,MTC=mtc][,LDC=ldc][,TIMEFILL=(tfc,cr,lf,ff,ws)];
[,CVC=cvc][,CMGS=cmsg][,COMP=comp][,ERI=eri];
[,TIMEOUT=timeout][,COMPRDID=did][,PCHAR=(start,stop)];
[,AUTOLF=autolf][,STATUS=status];
[,DUALSCRN=dualscrn]

```

ICAM Related Features

OS/3 ICAM restricts terminal names to four characters. If the Telcon term-name is more than four characters, you must use the OS/3 ICAM PSEUDO keyword on the OS/3 TERM macro.

Using the Telcon ALOC and DEST fields allows you to have a static-like session with OS/3. The terminal operator does not need to \$\$\$SON or \$\$\$OPEN. Telcon static sessions and ICAM static sessions are not supported under DTP protocol. See the descriptions for ALOC and DEST.

A.2.8. XEU Statement

Description

XEU statements define a CSU (LOCAP) associated with OS/3 ICAM or an external end user. Enter each XEU statement once in a configuration and it will be included automatically in all DCP configurations.

XEU statements are used only with the dynamic system session establishment feature.

Format

```

name XEU [CSU=csu][,DPP=dpp] [,DCATS=ts1], <or> [,TS=ts1], <or> [,TS=(ts1,...,tsn)];
[,SRCTSU=srctsu];
[,DESTTSU='desttsu'];
[,DESTSSU='destssu'];
[,DESTASU='destasu'];
[,TPFAC=tpfac] or [,TPFAC=(tpfac,...,tpfac)];
[,TPDU=(racnt,mrcnt)];
[,TIMEOUT=timeout]

```

ICAM Related Features

The name or DESTSSU must match the name on the ICAM local LOCAP or TERM macro.

The SRCTSU, DESTTSU, and DESTASU parameters should use defaults.

The name or DESTSSU and application ids you choose cannot exceed four characters.

A.3. ICAM Macroinstructions

This section describes the macros needed to support a Telcon network. Each format includes only those operands needed for this environment.

Macro	Description
BUFFERS	Establishes network and activity request packet pools and creates other resources needed by ICAM
CCA	Identifies the beginning of a network, the type of network, ICAM features, and journaling requirements
DCPCHNL	Defines the CHANNEL physical connection between an OS/3 host and a Telcon DCP.
ENDCCA	Indicates the end of a network definition
LOCAP	Creates a LOCAP file for your programs that use global networks
LPORT	In distributed communications architecture, enables ICAM to record and control activity at a logical port
TERM	Defines the characteristics of each terminal
VLINE	Defines the UDLC physical connection between an OS/3 host and a Telcon DCP

Table A-1 shows the order of presentation of the macros in a DCA Telcon environment.

Note: Before starting to define your ICAM network, refer to A.4 for the operands that must match those in the Telcon network. The composition of macros in the following sections will differ from those in Section 2.

Table A-1. Presentation Order of Macros in a DCA Telcon Network Environment

Macro Name	Remarks
CCA	Identifies the beginning of a network definition.
BUFFERS	Generates required system resources.
LOCAP1 : LOCAPn	Identifies all local user programs and I/S, DDP, TIP, IMS users in this computer host.
LINE1	Specifies characteristics of all local lines connected to an OS/3 host.
TERM1 TERMn : LINEn TERMn	Specifies characteristics of all terminals on this line.
DISCFILE1 : DISCFILEn	Specifies disk files used for this network.
PRCS1 : PRCSn	Specifies all process files in this network.
SESSION1 : SESSIONn	Specifies all static local sessions between local end users. (Local means in this computer host - LOCAP1 and PRCS1.)
VLINE or DCPCHNL	Identifies physical connection between an OS/3 host and a Telcon front end processor (DCP). It can be a UDLC or CHANNEL connection.
LPORT1 : LPORTn	Identifies all local end users (and remote end users if they reside in another host) and assigns a logical port number to each.
LOCAP1 : LOCAPn	Identifies all DDP, I/S, TIP, IMS, and remote user programs that reside in another host.
TERM1 : TERMn	Identifies all remote terminals that are physically connected to a DCP via Telcon lines or connected to another host.
ENDCCA	Identifies the end of this network definition.

A.3.1. How to Specify Buffer Pools, Activity Request Packet Pools, and Other ICAM Resources (BUFFERS)

Use the BUFFERS macro to create a network buffer pool, an activity request packet pool, a link buffer pool and a user data unit control table pool (UDUCT). All pools are located within your network communications control area. You may also specify statistical areas to keep track of ICAM use of the pools so you can adjust pool sizes according to your needs.

Specify this macro only once in each network definition.

Format

LABEL	OPERATION	OPERAND
not used	BUFFERS	[num,size][,thresh] [,EXPFACT= { n }],ARP=integer [,STAT=YES] [,UDUCT=(num[, ,thresh])] [,LINKPAK=(num,size[,thresh])] [,RTIMER= { (num) }]

The following describes what is required to support a Telcon network. See 2.2 for additional operands and details.

Operands

num
Specifies the number of network buffers you want in your network buffer pool. See 2.2 for details.

size
Is the length of your network buffers in 4-byte words. See 2.2 for details.

thresh
See 2.2 for details.

EXPFACT=n
Specifies an ICAM buffer pool expansion factor. You may specify 0 to 100 (percent). See 2.2 for details.

ARP=integer
Creates an activity request packet pool. The number you specify is the number of 14-word (56-byte) activity request packets available to ICAM to perform its functions.

To determine the *integer* value for DCA sessions supporting Telcon, DDP, and processor-to-processor configurations, add:

6 for ICAM
6 per VLINE/DCPCHNL
1 for each session allowed

Note: *DMI users should allow 3 per interactive services sessions and 3 per DDP session.*

STAT=YES

Creates network buffer pool and activity request packet pool statistics areas that keep track of pool usage.

UDUCT=(num, , [thresh])

Specifies the number of user data unit control tables. They are always 28-word areas that control data transmission and supply information about messages (senders, receivers, ports, and sessions) in Telcon, processor-to-processor networks, distributed data processing, and remote workstations.

For non-RWS configurations, allow at least 1 1/2 times the maximum number of sessions which would be active at any given time. Set the *thresh* value to 3.

LINKPAK=(num, size[, thresh])

Specifies the number, size, and threshold value of link buffers. Use these with distributed data processing, RWS support, public data networks, TELCON, and processor-to-processor networks.

num

Specifies the number of link buffers. Use the following formula to determine the maximum number required:

$$\text{num} = (\text{mpm} \times \text{maxsess}) + 1/2 \text{maxsess}$$

where:

num

Is the number of link-buffers for this network.

mpm

Is the number of link buffers required to hold the largest message passed over a UDLC line/DCPCHNL. Compute *mpm* by dividing the length of the largest message by the value specified in the *mxdt* parameter on the size of formula (rounded to the next whole word).

maxsess

Is the maximum number of sessions that will be active on a UDLC line/DCPCHNL at any given time.

size

Specifies the length of the link buffer in words (one word equals four bytes). Specify either 80 or the results of following formula, (use the larger of the two):

$$\text{size} = (\text{prfxhdr} + \text{mxdta})/4$$

where:

prfxhdr

Is the length of the link buffer prefix plus headers (74 bytes if VLINE is used; 84 bytes if DCPCHNL is used.)

mxdta

Is an average data size (bytes) to be transmitted. Larger output will be broken into segments.

4

Converts *prfxhdr* and *mxdta* to words.

Note: When the CCA specifies a 56,000 baud VLINE, the LINKPAK size must be at least 280 words.

thresh

Specifies a threshold value. Use the following formula:

$$\text{thresh} = 10\% \text{ of value specified for num}$$

Note: num and thresh will decrease when size increases.

RTIMER= $\left\{ \begin{array}{l} (\text{num}) \\ 50 \end{array} \right\}$

Specifies the number of 3-word timer stack entries used with Telcon, processor-to-processor, and distributed data processing. Maximum number needed should equal the number of ports plus the number of active sessions. The default value is 50.

A.3.2. How to Indicate the Start of the Network Definition and Specify the General Network Characteristics (CCA)

This macro identifies the beginning of an ICAM network definition, and the type of network and support you want ICAM to provide in the network.

Format

LABEL	OPERATION	OPERAND
network-name	CCA	[TYPE=(GBL,,node)] [,DCA=YES] [FEATURES=([,OPCOM] [,OUTDELV])] [,GAWAKE=YES] [,DCPLOAD=YES]

The following describes what is required to support a Telcon network. See 2.3 for additional operands and details.

Label

network-name

Is a 1- to 4-character label beginning with an alphabetic character that identifies this network. This is the name the global user service task (GUST) needs to activate your global network. Do not use labels beginning with LD or LT. These prefixes have special meaning for system generation.

Operands

TYPE=(GBL,,node)

GBL

Indicates this is a standard interface global network definition. Two commas must follow the GBL operand.

node

Is a 1- to 4-character computer node identifier for the computer in which this network operates. Any non-null character string that begins with an alphabetic character may be specified. This identifier must not match the label field of any other macro within the network definition.

DCA=YES

Indicates support of distributed communications architecture (DCA). Note that you must also specify GAWAKE=YES.

FEATURES=

OPCOM

Includes routines necessary to support unsolicited console type-ins to ICAM. This feature is not supported for NTR networks.

OUTDELV

Includes routines to support the ICAM output delivery notice feature.

GAWAKE=YES

Includes the routines to support the ICAM GAWAKE feature. The GAWAKE feature enables any task to activate an ICAM user program that has yielded, and optionally send to the user program a message known as a datagram.

If you want dynamically established sessions in your global network, specify this operand.

DCPLOAD=YES

This operand must be included if a DCP is to be downline loaded or cross-channel loaded by ICAM.

A.3.3. How to Specify DCP Channel Characteristics (DCPCHNL)

The DCPCHNL macro generates a link vector table that enables ICAM to record and control the Telcon DCP channel activity. One DCPCHNL macro is required for each Telcon front-end processor connected to the System 80 Model 8, 10,15, or 20.

Format

LABEL	OPERATION	OPERAND
channel - name	DCPCHNL	CNID=channel - number , ID=subchannel - address , REMOTE=destination - node

The following describes what is required to support a Telcon network. See 2.7 for additional details.

Label

channel - name

Specifies a 1- to 4-character identifier of the channel connecting OS/3 to the DCP. This name must be the same identifier specified in the LINE operand of the LPORT macro and used in console commands relating to this channel.

Note: 1, 2, 3, 6, and 7 are valid channel numbers for model 8.

Operands

CNID=channel - number

Specifies the channel number in the range of 1-6 as specified in the CACH macro of COMMCT.

ID=subchannel - address

Specifies the control unit address as specified for the reporting line number in the CACH macro of COMMCT. This address is strapped by a customer service engineer into a memory board of the channel interface in the DCP according to your request. Although the value is strapped in hexadecimal, it is specified in decimal for ID= with valid values of 8 to 15.

REMOTE=destination - node

Specifies a 1- to 4-character name for addressing the Telcon front-end processor connected to the System 80 host. The name must be the same as the name field of the Telcon DCPTS statement.

A.3.4. How to Indicate the End of Your Network Definition (ENDCCA)

This macro indicates the end of a network definition.

Format

LABEL	ΔOPERATIONA	OPERAND
not used	ENDCCA	not used

A.3.5. How to Create a LOCAP File for Global Networks (LOCAP)

This macro creates a local (in this computer) or remote (in a different computer) LOCAP file for programs that use a global network.

Format

LABEL	OPERATION	OPERAND
LOCAP-name	LOCAP	TYPE= ((STDMP) DMI) TCI) [,LOW= { MAIN filename }] [,MEDIUM= { MAIN filename }] [,HIGH= { MAIN filename }] [,REMOTE=(node)] [,IAS=(YES,OFF)]

The following explains what is required to support a Telcon network. See 2.15 in this manual for additional operands and details.

Label

LOCAP-name

Identifies a LOCAP file. It is the name your program must specify in the APPS operand of an NATTACH interface macro when it requests attachment to this global network. Other communications user programs direct messages to this LOCAP file by this label.

Operands

TYPE=(~~STDMP~~)

Specifies the standard interface used to communicate with this LOCAP file.

TYPE=(DMI)

Specifies the demand mode interface used to communicate with this LOCAP file. Required if ICAM supports interactive services to allow terminals to be used as workstations, or for distributed data processing users.

TYPE=(TCI)

Specifies the transaction control interface for the information management system (IMS) or TIP.

LOW, MEDIUM, and HIGH

Generates up to three input queues for messages destined for this LOCAP file. At least one of these queues is necessary for direct communications between your programs in a local or multicomputer global network, or if any terminals specify this LOCAP file in the INPUT operand of the TERM macro.

LOW=MAIN

Creates a main storage input queue with low priority.

LOW=filename

Specifies a 1- to 7-character name of a disk file for low priority messages you created using a DISCFILE macro.

MEDIUM=MAIN

Creates a main storage input queue with medium priority.

MEDIUM=filename

Specifies a 1- to 7-character name of a disk file for medium priority messages you created using a DISCFILE macro.

HIGH=MAIN

Creates a main storage queue with high priority.

HIGH=filename

Specifies a 1- to 7-character name of a disk file for high priority messages you created using a DISCFILE macro.

REMOTE=(node)

Use this operand only in a computer-to-computer environment that may pass through Telcon. It specifies a 1- to 4-character name that identifies the remote computer. (This is the same name specified for the REMOTE keyword on the LPORT macro.)

This LOCAP statement must follow the associated VLINE or DCPCHNL and LPORT statements.

IAS=(YES,OFF)

Specifies that interactive services are required (YES) but DICE is not (OFF). When TYPE=(DMI) is specified, use this operand.

Telcon Related Features

The LOCAP-name must match the name or DESTSSU on a Telcon XEU statement, or the name of a LOCAP or application in a remote processor.

A.3.6. How to Create Remote Session Entry Tables (LPORT)

Use the LPORT macro to define and create a table for each DCA logical port. ICAM uses the information in this table to record and control activity on the port.

Format

LABEL	OPERATION	OPERAND
not used	LPORT	<pre> { LINE=name, REMOTE=name, PORT=nnnn, EU1=name, EU2=name, USERTP= { DMI { TCI { STDWCP } } } , PRI= { 1 { 2 { 3 { # } } } </pre>

The following details what is required to support a Telcon Network. See 2.16 for additional operands and details.

Operands

LINE=name

Is the 1- to 4-character label from the VLINE or DCPCHNL macro. Begin the name with an alphabetic character.

REMOTE=name

Is the 1- to 4-character name of the destination processor. If a Telcon DCP is the destination, this name must match the name on the Telcon DCPTS macro. If another processor is the destination, this name must match the name on the Telcon DCATS macro for that processor.

PORT=nnnn

Is a 4-digit port number in the range of 1 to 4096. This number must match the Telcon *lsch* field on the SESSN statement. If another processor is the destination, this must match a port number there.

EU1=name

Is the label of the TERM, PRCS, or LOCAP macro defining the local end user.

EU2=name

Is the label of the TERM or LOCAP macro defining the remote end user (computer to computer). Do not supply this name for a program to Telcon terminal session.

LPORT

USERTP= { DMI
 TCI
 STDNCP }

Indicates that the session operates through the demand mode interface, transaction control interface, or standard interface for DCA global networks. The user type is referenced by ICAM for outbound session opens.

PRI=n

Indicates priority from 1 to 4. The default is 4. The highest priority is 1.

Telcon Related Features

Refer to the descriptions of the ICAM REMOTE and PORT operands of the LPORT macro.

A.3.7. How to Specify Terminal Characteristics (TERM)

The TERM macro specifies the characteristics of each remote terminal in your ICAM network. Each TERM macro must follow the VLINE or DCPCHNL macro. These terminals are physically connected to a Telcon DCP or another processor.

Format

LABEL	OPERATION	OPERAND
term-name	TERM	<pre> FEATURES= (U100 , { 960 } { 1024 } (U200 , { 1536 } { 1920 } (U400 [{ 960 } [SBT] [{ CP }] [, CC] { 1024 } { 1536 } { 1920 })) (U20 [{ 960 }] [, SBT] [, CC] [{ PRIMARY }] { 1920 } [{ SECONDARY }]) (U40 [{ 960 }] [, CC] [{ PRIMARY }] { 1920 } [{ SECONDARY }]) [,AUX1=(aux-dev-id) [,... ,AUX44=(aux-dev-id)]] [,INPUT { name } [,blanks] [,filename] { YES }] [,LOW= { filename } { MAIN }] [,MEDIUM= { filename } { MAIN }] [,HIGH= { filename } { MAIN }] [,PSEUDO=Telcon-term-name] [,REMOTE=(node-id)] [,DICE= ((ON) , { NEWLINE }) (OFF) { FORMS })] [,XLATE= (({ YES } { NO }) ({ YES } { labeli , idi }) ({ NO } { labelo , ido }))] [,DVCID=terminal-group-name] [,PROTYP= { DEV } { INT-1 }] </pre>

The following describes what is required to support a Telcon network. See 2.25 for additional operands and details.

Label**term-name**

Is a 4-character label that identifies the terminal. It must match either the term-name in the Telcon generation or local term-name in a remote processor.

Note: If the Telcon term-name is more than four characters, you must use the PSEUDO keyword in this macro in order to match terminal names.

Operands**FEATURES=**

Identifies the characteristics of this terminal and the features supported, as specified in the Telcon generation. See 2.25 for details.

AUX1=(aux-dev-id)[,.. ,AUX44=(aux-dev-id)]

The AUXn operands specify device addresses for auxiliary devices connected to this terminal. The AUXn operand must match the Telcon DEVICE macro for a terminal. See 2.25 for details.

**INPUT= {name} [,blanks][,filename]
{YES}**

Establishes a destination for messages input at this terminal. See 2.25 for details.

LOW, MEDIUM, and HIGH

Creates low, medium, and high priority terminal output queues in main storage or on disk for this terminal. See 2.25 for details.

PSEUDO=Telcon-term-name

Matches the terminal name specified in a Telcon generation which is greater than four characters. Do not use this keyword if four characters or less are used; it would only create extra processing.

REMOTE=(node-id)

Specifies the remote processor to which this terminal is connected. Node-id is a 1- to 4-character name. It must match both the destination node specified in the LPORT macro and the Telcon DCPTS macro-name.

**DICE= ({ON} , {NEWLINE})
{OFF} {FORMS}**

Describes how you want device independent control expressions (DICE) used with this terminal. See 2.25 for details.

XLATE= (({ YES }) ({ NO })) (({ YES }) ({ NO }))
 (label i, idi) (label o, ido)

The XLATE operand lets you specify the translation table you want to use for input from this terminal and also the one you want to use for output going to this terminal. See 2.25 for details.

DVCGID=terminal-group-name

Specifies the name of a remote terminal group in a DCA. The DVCGID operand must be one of the following names:

Interactive Terminals

INT33 for UNISCOPE

INT41 for UTS 400

INT51 for all others

PROTYP= { DEV }
 { INT-1 }

Describes how data is presented by the terminal. DEV specifies device dependent for terminals attached to a remote OS/3 host. INT-1 specifies interactive terminals attached to a distributed communications processor (DCP).

Telcon Related Features

Refer to the preceding descriptions for *term-name*, *AUXn*, *REMOTE*, and *PSEUDO* on the ICAM TERM macro.

A.3.8. How to Specify Virtual Channels (VLINE)

Use the VLINE macros to specify the physical link that connects an OS/3 host to a Telcon DCP. It is a UDLC connection.

You must specify all resources that relate to a particular VLINE before you define any additional VLINES.

LABEL	OPERATION	OPERAND
symbol	VLINE	<pre> ID=slca-number ,DEVICE=ABM,DCA2 [,CHAN=channel-number] [,K {value}] [,TYPE= {line-speed}] [,CMDADDR= {n}] [,RSPADDR= {n}] </pre>

The following describes what is required to support a Telcon network. See 2.28 for additional operands and details.

Label

symbol

Is a 1- to 4-character name of this physical link. It is also referenced by the LPORT macro.

Operands

ID=slca-number

For System 80 models 3 through 6, the *slca-number* is specified as a number between 8 and 15 identifying the line number of the single line communications adapter (SLCA). For System 80 models 8 - 20, the *slca-number* can be from 1 to 15 for each input/output microprocessor (IOMP).

DEVICE=ABM,DCA2

Specifies the type of protocol used on this link.

ABM,DCA2

Specifies this line is used for communications between an OS/3 host and a DCP or two OS/3 DCA termination systems.

CHAN=channel-number

Specifies the input/output microprocessor (IOMP) to which the single-line communications adapter (SLCA) is connected. See 2.28 for details.

K= { value }
7

Specifies the number of frames (K window value) that can be sent or received across this virtual link before an acknowledgment is required. You can specify a value of 1 to 7. You must specify K=1 if connected to a DCP or passing through a DCP to another OS/3 host.

TYPE= { line-speed }
9600

Specifies the rate (Baud) at which data is transferred between two computers described in this macro. Line speed is a function of the modems used. Acceptable values are: 2400, 4800, 9600, 19200, 48000, and 56000.

CMDADDR= { n }
n

Is a decimal number between 1 and 255 specifying the universal data link control frame level address used to transmit commands and receive responses. The default value is 1.

RSPADDR= { n }
3
n

Is a decimal number between 1 and 255 specifying the universal data link control frame level address used to transmit responses and receive commands. The default value is 3.

Note: *CMDADDR* and *RSPADDR* are required only for *DEVICE=ABM*.

Telcon Related Features

The *CMDADDR* operand must match the Telcon *lsa* field in the *STATION* statement. The *RSPADDR* operand must match the Telcon *rsa* field in the *STATION* statement.

A.4. Telcon/ICAM Macroinstruction Relationships

Some labels and parameters of the Telcon configuration statements must be the same as those in the ICAM network definition. Table A-2 lists them with the equivalent ICAM macro and operand or label.

Table A-2. Telcon/ICAM Macroinstruction Relationships

Telcon		ICAM	
Statement	Parameter or Label	Macro	Operand or Label
CHANNEL		DCPCHNL	
DCATS	name	LOCAP LPORT TERM	REMOTE=name*
DCPTS	name	LPORT TERM	REMOTE=name**
DEVICE	TYPE=dev-type ADR=(dev-adr1, dev-adr2)	TERM	AUXn=(dev-id,did)
SESSN	lsch	LPORT	PORT=port-number
STATION	LSA RSA	VLIN	CMDADDR=lsa RSPADDR=rsa
TERM	name TYPE	TERM	name FEATURES=term-type PSEUDO=Telcon-term-name
XEU	xeu-name DESTSSU	LOCAP TERM	name name***

- * Defines name associated with a remote host computer. Use the DCATS name only when connecting an OS/3 host to another host (OS/3, UNIX, etc.) through a DCP.
- ** Defines name associated with the terminating DCP.
- *** Used only when connecting an OS/3 terminal to a DCP terminal.

A.5. A Comparison Between Telcon and ICAM Terminal Operation

Terminal operation differs between Telcon and ICAM. The current version of *OS 1100/DCP Series, Communications Delivery Software, Guide to Terminal Operation* (UP-10041) gives general terminal commands and error messages.

Note: There are four ways to start a Telcon session, depending on whether your interactive terminal is set up for automatic sign-on and session establishment. Refer to UP-10041.

Telcon uses the following format to establish an interactive terminal session:

`$$$ON xxxx`

where:

`xxxx`

Is the terminal name. This connects your terminal with the Telcon network.

`$$OPEN yyyy`

where:

`yyyy`

Is the application name. This establishes a session with the application specified.

`$$CLOSE`

Terminates the session with ICAM. (Telcon resources still exist.)

`$$$OFF`

Terminates the connection with the terminal. Both ICAM and Telcon resources are released.

You don't need to issue a `$$CLOSE` command when you want to change sessions. Simply key in another `$$OPEN` command. This closes the current session and establishes a new one.

Terminal Operation Comparison

ICAM uses the following format:

\$\$\$SON xxxxyyyy

where:

xxxx

Is the terminal name.

yyyy

Is the application name.

\$\$\$OFF

Terminates the session and connection to the terminal.

Examples

TELCON	\$\$\$SON	TRM1	Connects the terminal to Telcon network
	\$\$OPEN	IMS1	Establishes a session with IMS1 application
	\$\$CLOSE		Terminates session with ICAM
	\$\$\$OFF		Terminates terminal connection
	--- OR ---		
	\$\$\$SON	TRM1	Connects the terminal to Telcon network
	\$\$OPEN	IMS1	Establishes a session with IMS1 application
	\$\$OPEN	IMS2	Closes the IMS1 session, establishes a session with IMS2 application
	\$\$CLOSE		Terminates session with ICAM
	\$\$\$OFF		Terminates terminal connection
ICAM	\$\$\$SON	TRM1IMS1	Establishes a session between the terminal and IMS1 application
	\$\$\$OFF		Terminates session
	\$\$\$SON	TRM1IMS2	Establishes a session between the terminal and IMS2 application
	\$\$\$OFF		Terminates session

A.6. Example Configurations for OS/3 Telcon Networks

This subsection contains four example network configurations. Each of the first three builds upon the preceding example by adding some components and capabilities. All examples include:

- A statement of the example's purpose
- Descriptions and explanations where necessary
- A diagram showing the components and their interconnections
- The OS/3 ICAM macroinstructions
- The Telcon network definition statements

Each example has only a few points to make. All are kept simple so the points to be made are not obscured by a multiplicity of components of the same or similar kinds.

Both the OS/3 ICAM macros and Telcon network definition statements are listed for each example. When they are shown in close proximity in this way, the differences in statement syntax or format stand out.

For the first three examples, one or more network definition statements from the previous example are changed in some way. These changes are shaded so you can pick them out easily.

For most network definition statements, you pick your own name or label, according to your own naming scheme.

Note: Only those Telcon statements related to OS/3 ICAM configuration are shown.

A.6.1. Example Configuration 1

Example 1 (Figure A-1) presents a very simple network configuration. There are four interactive terminals and one DCP. It is a front-end processor (FEP) connected directly to the host computer.

We don't show the DCP port identification numbers in the figures. You can find them by looking at the ADR values for lines. It is helpful if you give each line a name that agrees with the number of the DCP port it connects to. For example, line LBD2D connects to port number 2D.

As you look at the network definition statements for these examples, you will notice that the DTP protocol is used where the DMF protocol was used in earlier releases of OS/3 ICAM and Telcon.

The example shows the use of a 6-character Telcon term-name (TERM23) and how the ICAM TERM macro for BA08 is defined to handle it.

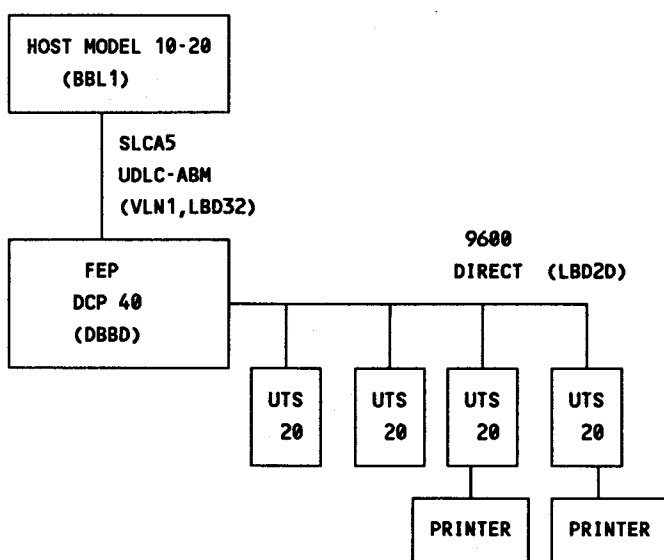

Figure A-1. Example Configuration 1

The components in Example Configuration 1 are:

- The OS/3 host computer
- One DCP 40 acting as a front-end processor for the host
- Four UTS 20 display terminals (two have printers)
- One 9600 baud direct, half-duplex UNISCOPE line

- One 56,000 baud direct UDLC line between the host and the front-end processor (FEP)

Figure A-2 shows the OS/3 ICAM macros that support Example Configuration 1.

UNISYS OS/3 SYSTEM GENERATION PARAMETER PROCESSOR				
RELEASE VERSION 112.0.0 DATE 88/09/18 TIME 17:00:35 PAGE 001				
CARD	ERROR	PHASE	CONFIGURATION PARAMETER	DIAGNOSTIC
0001		COMMCT		
0002		BBL1	CCA	TYPE=(GBL,,OS3A),DCA=YES,
0003				FEATURES=(OPCOM,OUTDELV),GAWAKE=YES
0004			BUFFERS	200,128,5,ARP=150,
0005				UDUCT=(20,28,2),
0006				LINKPAK=(80,280,8),RTIMER=10
0007		*		
0008		STD1	LOCAP	TYPE=(STDMCP),LOW=MAIN,MEDIUM=MAIN,HIGH=MAIN
0009		MAP1	LOCAP	TYPE=(STDMCP),LOW=MAIN,MEDIUM=MAIN,HIGH=MAIN
0010		DMI1	LOCAP	TYPE=(DMI),IAS=(YES,OFF),
0011				LOW=MAIN,MEDIUM=MAIN,HIGH=MAIN
0012		*		
0013		TCI1	LOCAP	TYPE=(TCI),LOW=MAIN
0014		*		
0015		VLN1	VLINE	DEVICE=(ABM,DCA2),TYPE=(56000),K=1,ID=12,
0016				CMDADDR=3,RSPADDR=1,CHAN=15
0017		*		
0018		*		HOST TO TELCON TERMINAL LPORT STATEMENTS
0019		*		
0020			LPORT	LINE=VLN1,PORT=55,EU1=DMI1,USERTP=DMI,
0021				REMOTE=DBBD
0022			LPORT	LINE=VLN1,PORT=56,EU1=STD1,USERTP=STDMCP,
0023				REMOTE=DBBD

Figure A-2. OS/3 ICAM Macros for Example Configuration 1 (Part 1 of 3)

Example Configurations

UNISYS OS/3 SYSTEM GENERATION PARAMETER PROCESSOR				
RELEASE VERSION 112.0.0		DATE 88/09/18	TIME 17:00:35	PAGE 002
CARD	ERROR	PHASE	CONFIGURATION PARAMETER	DIAGNOSTIC
0024			LPORT LINE=VLN1,PORT=57,EU1=MAP1,USERTP=STDMCP,	X
0025			REMOTE=DBBD	
0026			LPORT LINE=VLN1,PORT=58,EU1=TCI1,USERTP=TCI,	X
0027			REMOTE=DBBD	
0028		BA05	TERM FEATURES=(U20,1920),DVCGID=INT33,LOW=MAIN,	X
0029			MEDIUM=MAIN,HIGH=MAIN,REMOTE=(DBBD),INPUT=YES,	X
0030			PROTYP=INT-1	
0031		BA06	TERM FEATURES=(U20,1920),DVCGID=INT33,LOW=MAIN,	X
0032			MEDIUM=MAIN,HIGH=MAIN,REMOTE=(DBBD),INPUT=YES,	X
0033			PROTYP=INT-1	
0034		BA07	TERM FEATURES=(U20,1920),DVCGID=INT33,LOW=MAIN,	X
0035			MEDIUM=MAIN,HIGH=MAIN,REMOTE=(DBBD),INPUT=YES,	X
0036			PROTYP=INT-1,AUX1=(COP,73)	
0037		BA08	TERM FEATURES=(U20,1920),DVCGID=INT33,LOW=MAIN,	X
0038			MEDIUM=MAIN,HIGH=MAIN,REMOTE=(DBBD),INPUT=YES,	X
0039			PROTYP=INT-1,AUX1=(COP,73),PSEUDO=TERM23	
0040			ENDCCA	
0041		*		
0042			MCP MCPNAME=C2	
0043			CACH=(12,56000,FULL,ILA),CHAN=15	
0044		END		

Figure A-2. OS/3 ICAM Macros for Example Configuration 1 (Part 2 of 3)

```
***** SYSRES CONFIGURATION SUMMATION *****  
  
          ICAM OUTPUT VOLUME = REL11L  
  
** SUPERVISORS **          ** COMMUNICATIONS **          ** NTRS **  
  
                                C2  
  
          SYSTEM GENERATION JOB STREAM SEQUENCE  
  
              1          RV          SG$COMMK  
  
          END OF REPORT
```

Figure A-2. OS/3 ICAM Macros for Example Configuration 1 (Part 3 of 3)

Figure A-3 shows the Telcon statements that correspond to the OS/3 macros in Example Configuration 1.

Example Configurations

```

TELVS9*NETWORK(1).DEB1(0)
 1 *****
 2 *
 3 * PRCSR (PROCESSORS) *
 4 * *
 5 *****
 6 *
 7 BBD PRCSR DSPL=ALL,LOGL=ALL,NMSR='RSC',NMSU=('RSC',144,,10),;
 8 STATS=(LINE,30)
 9 *
10 *****
11 *
12 * DCPTS (DCP TERMINATION SYSTEMS) *
13 * *
14 *****
15 *
16 DBBD DCPTS PRCSR=BBD
17 *
18 *****
19 *
20 * DCATS (DCA TERMINATION SYSTEMS) *
21 * *
22 *****
23 BBL1 DCATS PRCSR=BBD *OS3-L1
24 *****
25 * OS3 SYSTEM L1 XEUS AND SESSIONS *
26 *****
27 DMI1 XEU TS=BBL1,DESTSSU='DMI1',DPP=INT1
28 STD1 XEU TS=BBL1,DESTSSU='STD1',DPP=INT1
29 MAP1 XEU TS=BBL1,DESTSSU='MAP1',DPP=INT1
30 TCI1 XEU TS=BBL1,DESTSSU='TCI1',DPP=INT1
31 *
32 *
33 DMI1BBL1 SESSN TS1=(DBBD,55,BBD),TS2=(BBL1,55,BBD)
34 STD1BBL1 SESSN TS1=(DBBD,56,BBD),TS2=(BBL1,56,BBD)
35 MAP1BBL1 SESSN TS1=(DBBD,57,BBD),TS2=(BBL1,57,BBD)
36 TCI1BBL1 SESSN TS1=(DBBD,58,BBD),TS2=(BBL1,58,BBD)
37 *****
38 * CLASS COMMUNICATION LINES/Common CHARACTERISTICS *
39 * *
40 *****
41 UN96D LCLASS LPH=U100L,SPEED=9600,OPTIONS=(DIR,SYHD)
42 UDLC560 LCLASS LPH=UDLCL,SPEED=64000

```

Figure A-3. Telcon Statements for Example Configuration 1 (Part 1 of 2)

```

43 *****
44 LBD32    LINE    PRCSR=BBD,CLASS=UDLC560,ADR=X'032' * OS3 L1 SYSTEM
45
46 *****
47 *        UDLC STATION BBD TO ALL OS3-NET SYSTEMS          *
48 *****
49 *
50 STAL1    STATION  LINE=LBD32,RSHLE=BBL1,MODE=ABM,LSA=3,RSA=1 * SYS L1
51 *****
52 *        MUX LINE DEFINITION STATEMENTS                    *
53 *****
54 LBD2D    LINE     PRCSR=BBD,CLASS=UN96D,ADR=02D
55 *****
56 *        MUX GROUP DEFINITION STATEMENTS                   *
57 *****
58 GP2D     GROUP    PRCSR=BBD,LINE=LBD2D
59 *****
60 *        TERMINAL STATEMENTS                                *
61 *****
62 BA05     TERM     GROUP=GP2D,TYPE=UTS20,ADR=(027,057)
63 BA06     TERM     GROUP=GP2D,TYPE=UTS20,ADR=(027,058)
64 BA07     TERM     GROUP=GP2D,TYPE=UTS20,ADR=(027,059)
65 BA07P1   DEVICE   TERM=BA07,TYPE=PRTR,ADR=(0,073)
66 TERM23   TERM     GROUP=GP2D,TYPE=UTS20,ADR=(027,05A)
67 TERM23P1 DEVICE   TERM=TERM23,TYPE=PRTR,ADR=(0,073)

```

Figure A-3. Telcon Statements for Example Configuration 1 (Part 2 of 2)

A.6.2. Example Configuration 2

Example 2 (Figure A-4) adds another host to the network configuration. This host is a UNIX processor configured to run IS5000. Refer to the *DIS/5000 User Guide* (UP-11816) for details on UNIX configuration.

In the OS/3 ICAM configuration, the LPORT and remote LOCAP macros define the UNIX end user.

In the Telcon configuration, the UNIX processor is set up as another host (DCATS).

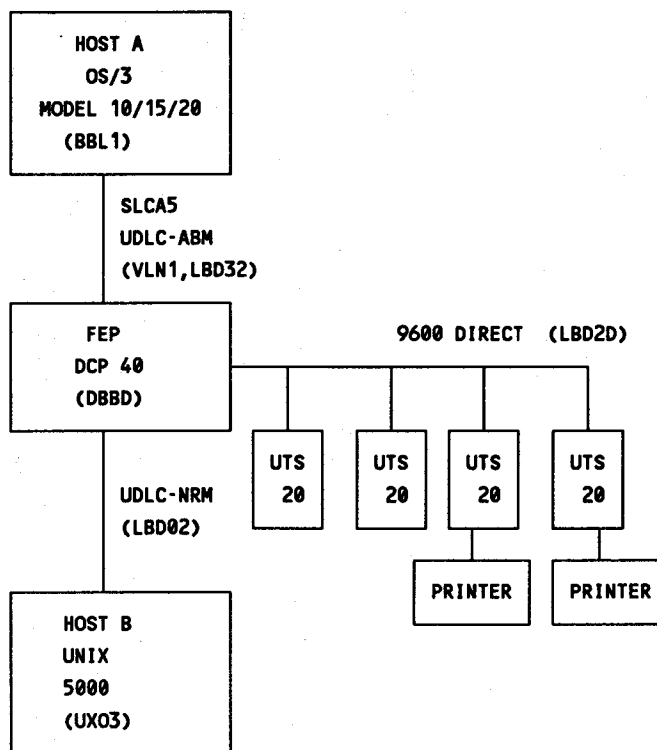

Figure A-4. Example 2 Configuration

The components in Example Configuration 2 are:

- The OS/3 host computer
- One DCP 40 acting as a front-end processor for the OS/3 host and the UNIX IS5000 host
- The UNIX IS5000 host

- Four UTS 20 display terminals connected to the DCP 40 (two of the terminals have printers)
- One 9600 baud direct, half-duplex UNISCOPE line
- One 56,000 baud direct UDLC line between the OS/3 host and the front-end processor (FEP)
- One 2400 baud direct UDLC, half-duplex line between the UNIX IS5000 host and the FEP

Figure A-5 shows the OS/3 ICAM macros that support Example Configuration 2.

UNISYS OS/3 SYSTEM GENERATION PARAMETER PROCESSOR				
RELEASE VERSION I12.0.0 DATE 88/09/18 TIME 17:00:35 PAGE 001				
CARD	ERROR	PHASE	CONFIGURATION PARAMETER	DIAGNOSTIC
0001		COMMCT		
0002		BBL1	CCA TYPE=(GBL,,OS3A),DCA=YES,	X
0003			FEATURES=(OPCOM,OUTDELV),GAWAKE=YES	
0004			BUFFERS 200,128,5,ARP=150,	X
0005			UDUCT=(20,28,2),	X
0006			LINKPAK=(80,280,8),RTIMER=10	
0007		*		
0008		STD1	LOCAP TYPE=(STDMCP),LOW=MAIN,MEDIUM=MAIN,HIGH=MAIN	
0009		MAP1	LOCAP TYPE=(STDMCP),LOW=MAIN,MEDIUM=MAIN,HIGH=MAIN	
0010		DMI1	LOCAP TYPE=(DMI),IAS=(YES,OFF),	X
0011			LOW=MAIN,MEDIUM=MAIN,HIGH=MAIN	
0012		*		
0013		TCI1	LOCAP TYPE=(TCI),LOW=MAIN	
0014		*		
0015		VLN1	VLINE DEVICE=(ABM,DCA2),TYPE=(56000),K=1,ID=12,	X
0016			CMDADDR=3,RSPADDR=1,CHAN=15	
0017		*		
0018		*	HOST TO HOST LPORT STATEMENTS	
0019		*		
0020			LPORT LINE=VLN1,PORT=59,EU1=DMI1,EU2=UNXH,USERTP=DMI,	X
0021			REMOTE=(UX03)	

Figure A-5. OS/3 ICAM Macros for Example Configuration 2 (Part 1 of 3)

Example Configurations

UNISYS OS/3 SYSTEM GENERATION PARAMETER PROCESSOR				
RELEASE VERSION I12.0.0 DATE 88/09/18 TIME 17:00:35 PAGE 002				
CARD	ERROR	PHASE	CONFIGURATION PARAMETER	DIAGNOSTIC
0022		*		
0023		*	HOST TO TELCON TERMINAL LPORT STATEMENTS	
0024		*		
0025			LPORT LINE=VLN1,PORT=55,EU1=DMI1,USERTP=DMI,	X
0026			REMOTE=DBBD	
0027			LPORT LINE=VLN1,PORT=56,EU1=STD1,USERTP=STDMCP,	X
0028			REMOTE=DBBD	
0029			LPORT LINE=VLN1,PORT=57,EU1=MAP1,USERTP=STDMCP,	X
0030			REMOTE=DBBD	
0031			LPORT LINE=VLN1,PORT=58,EU1=TCI1,USERTP=TCI,	X
0032			REMOTE=DBBD	
0033		*		
0034		*	REMOTE LOCAPS	
0035		*		
0036		*	UNXH LOCAP TYPE=(DMI),LOW=MAIN,MEDIUM=MAIN,HIGH=MAIN,REMOTE=(UXO3)	
0037		*		
0038		*	REMOTE TELCON TERMINALS	
0039		*		
0040	BA05	TERM	FEATURES=(U20,1920),DVCGID=INT33,LOW=MAIN,	X
0041			MEDIUM=MAIN,HIGH=MAIN,REMOTE=(DBBD),INPUT=YES,	X
0042			PROTYP=INT-1	
0043	BA06	TERM	FEATURES=(U20,1920),DVCGID=INT33,LOW=MAIN,	X
0044			MEDIUM=MAIN,HIGH=MAIN,REMOTE=(DBBD),INPUT=YES,	X
0045			PROTYP=INT-1	
0046	BA07	TERM	FEATURES=(U20,1920),DVCGID=INT33,LOW=MAIN,	X
0047			MEDIUM=MAIN,HIGH=MAIN,REMOTE=(DBBD),INPUT=YES,	X
0048			PROTYP=INT-1,AUX1=(COP,73)	
0049	BA08	TERM	FEATURES=(U20,1920),DVCGID=INT33,LOW=MAIN,	X
0050			MEDIUM=MAIN,HIGH=MAIN,REMOTE=(DBBD),INPUT=YES,	X
0051			PROTYP=INT-1,AUX1=(COP,73),PSEUDO=TERM23	
0052			ENDCCA	

Figure A-5. OS/3 ICAM Macros for Example Configuration 2 (Part 2 of 3)

UNISYS OS/3 SYSTEM GENERATION PARAMETER PROCESSOR

RELEASE VERSION I12.0.0 DATE 88/09/18 TIME 17:00:35 PAGE 003

CARD	ERROR	PHASE	CONFIGURATION PARAMETER	DIAGNOSTIC
0053		*		
0054			MCP MCPNAME=C2	
0055			CACH=(12,56000,FULL,ILA),CHAN=15	
0056		END		

***** SYSRES CONFIGURATION SUMMATION *****

ICAM OUTPUT VOLUME = REL11L

** SUPERVISORS ** ** COMMUNICATIONS ** ** NTRS **

C2

SYSTEM GENERATION JOB STREAM SEQUENCE

1	RV	SG\$COMMK
---	----	-----------

END OF REPORT

Figure A-5. OS/3 ICAM Macros for Example Configuration 2 (Part 3 of 3)

Figure A-6 shows the Telcon statements that correspond to the OS/3 macros in Example Configuration 2.

Example Configurations

```

TELVS9*NETWORK(1).DEB1(0)
1      *****
2      *
3      * PRCR (PROCESSORS)
4      *
5      *****
6      *
7      BBD      PRCR      DSPL=ALL,LOGL=ALL,NMSR='RSC',NMSU=('RSC',144,,10),;
8                      STATS=(LINE,30)
9      *
10     *****
11     *
12     * DCPTS (DCP TERMINATION SYSTEMS)
13     *
14     *****
15     *
16     DBBD      DCPTS      PRCR=BBD
17     *
18     *****
19     *
20     * DCATS (DCA TERMINATION SYSTEMS)
21     *
22     *****
23     BBL1      DCATS      PRCR=BBD *OS3-L1
24     UX03      DCATS      PRCR=BBD *OS3-UNIX
25     *****
26     *          OS3 SYSTEM L1 XEUS AND SESSIONS
27     *****
28     DMI1      XEU          TS=BBL1,DESTSSU='DMI1',DPP=INT1
29     STD1      XEU          TS=BBL1,DESTSSU='STD1',DPP=INT1
30     MAP1      XEU          TS=BBL1,DESTSSU='MAP1',DPP=INT1
31     TCI1      XEU          TS=BBL1,DESTSSU='TCI1',DPP=INT1
32     *
33     *
34     DMI1BBL1  SESSN        TS1=(DBBD,55,BBD),TS2=(BBL1,55,BBD)
35     STD1BBL1  SESSN        TS1=(DBBD,56,BBD),TS2=(BBL1,56,BBD)
36     MAP1BBL1  SESSN        TS1=(DBBD,57,BBD),TS2=(BBL1,57,BBD)
37     TCI1BBL1  SESSN        TS1=(DBBD,58,BBD),TS2=(BBL1,58,BBD)
38     *
39     *****
40     *          HOST TO HOST SESSIONS
41     *****
42     UNX1BBL1  SESSN        TS1=(UX03,75,BBD),TS2=(BBL1,59,BBD)

```

Figure A-6. Telcon Statements for Example Configuration 2 (Part 1 of 2)

```

43 *****
44 *          CLASS COMMUNICATION LINES/Common Characteristics          *
45 *                                                                 *
46 *****
47 UN96D      LCLASS      LPH=U100L,SPEED=9600,OPTIONS=(DIR,SYHD)
48 UNIX92     LCLASS      LPH=UDLCL,SPEED=2400,OPTIONS=(DIR,SYHD)
49 UDLC560    LCLASS      LPH=UDLCL,SPEED=64000
50 *****
51 LBD32      LINE        PRCSR=BBD,CLASS=UDLC560,ADR=X'032' * OS3 L1 SYSTEM
52 LBD02      LINE        PRCSR=BBD,CLASS=UNIX92,ADR=X'02' * UNIX SYSTEM
53
54 *****
55 *          UDLC STATION BBD TO ALL OS3-NET SYSTEMS                    *
56 *****
57 *
58 STAL1      STATION     LINE=LBD32,RSHLE=BBL1,MODE=ABM,LSA=3,RSA=1 * SYS L1
59 STAUNIX    STATION     LINE=LBD02,RSHLE=UX03,MODE=NRM,LSTYP=PRIM,RSA=08A
60 *****
61 *          MUX LINE DEFINITION STATEMENTS                            *
62 *****
63 LBD2D      LINE        PRCSR=BBD,CLASS=UN96D,ADR=02D
64 *****
65 *          MUX GROUP DEFINITION STATEMENTS                          *
66 *****
67 GP2D       GROUP       PRCSR=BBD,LINE=LBD2D
68 *****
69 *          TERMINAL STATEMENTS                                       *
70 *****
71 BA05       TERM        GROUP=GP2D,TYPE=UTS20,ADR=(027,057)
72 BA06       TERM        GROUP=GP2D,TYPE=UTS20,ADR=(027,058)
73 BA07       TERM        GROUP=GP2D,TYPE=UTS20,ADR=(027,059)
74 BA07P1     DEVICE      TERM=BA07,TYPE=PRTR,ADR=(0,073)
75 TERM23     TERM        GROUP=GP2D,TYPE=UTS20,ADR=(027,05A)
76 TERM23P1   DEVICE      TERM=TERM23,TYPE=PRTR,ADR=(0,073)

```

Figure A-6. Telcon Statements for Example Configuration 2 (Part 2 of 2)

Example Configurations

UNIX Configuration

The following are the UNIX parameters required for Host B to support Example Configuration 2.

Local UNIX Parameters

SDLC address: 8A

Matches RSA= on Telcon STATION statement named STAUNIX.

OWN HOST ID: UNXH

Matches ICAM remote LOCAP name in BBL1 CCA.

Remote Host ID/Logical Channel Definitions

DMI1/75

DMI1 matches ICAM local LOCAP name in BBL1 CCA; 75 matches TS1 *lsch* on Telcon SESSN statement UNX1BBL1. If DDP is not used within the DCP, there is no requirement for the DCATS name (UXO3) in TS1 to be the same as the DDP host ID (UNXH).

Refer to the *DIS/5000 User Guide* (UP-11816) for details on UNIX - Telcon host configuration.

A.6.3. Example Configuration 3

Example Configuration 3 (Figure A-7) adds an OS/3 host (Host C) with its own communications lines and terminals. The terminals connected to Host C are defined as local to Host C and are included in this example to illustrate order of macro presentation in the ICAM generation. There is no intent here to have these terminals be in session with another host.

Host C is connected to the DCP40 (FEP A) via an SU0039 CHANNEL. The terminals connected to the DCP40 can be in session with Host A and/or Host C.

Example Configuration 3 shows the relationships between the OS/3 ICAM LPORT and remote LOCAP macros, the UNIX parameters, and the Telcon SESSN statements for host to host and host to Telcon terminal connections through the DCP.

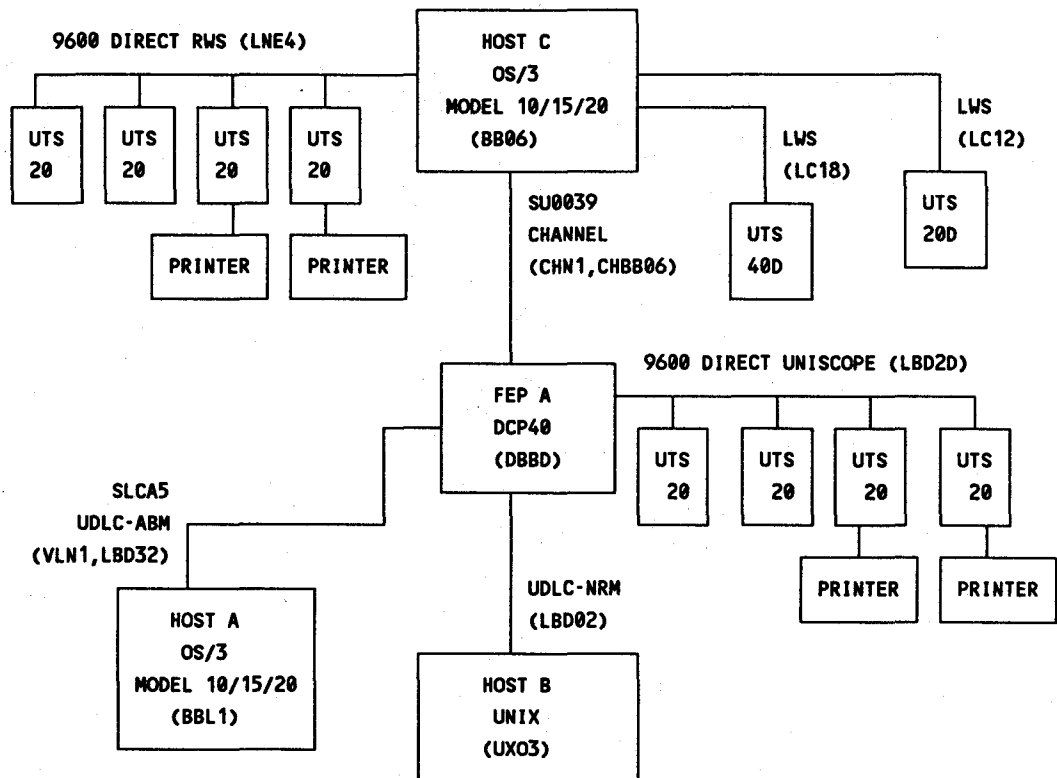

Figure A-7. Example Configuration 3

The components for Example Configuration 3 are:

Example Configurations

- Two OS/3 host computers (Hosts A and C)
- The UNIX IS5000 host (Host B)
- One DCP40 acting as a front-end processor for both OS/3 hosts and the UNIX IS5000 host
- One SU0039 channel between OS/3 Host C and the FEP
- One 56,000 baud direct UDLC line between OS/3 Host A and the front-end processor (FEP)
- One 2400 baud direct UDLC half-duplex line between Host B (the UNIX IS5000) and the FEP
- One 9600 baud direct half-duplex UNISCOPE line connected to DCP40
- Four display terminals connected to DCP40, some with printers
- One 9600 baud direct RWS line connected to OS/3 Host C
- Four UTS 20 terminals, two with printers attached to OS/3 Host C RWS line
- Two LWSs connected to OS/3 Host C

Figure A-8 shows the OS/3 ICAM macros for Host C used in Example Configuration 3.

```

UNISYS OS/3 SYSTEM GENERATION PARAMETER PROCESSOR

RELEASE VERSION I12.0.0   DATE 88/09/18   TIME 17:00:35   PAGE 001

```

CARD	ERROR	PHASE	CONFIGURATION PARAMETER	DIAGNOSTIC
0001		COMMCT		
0002		BB06	CCA TYPE=(GBL,,OS3A),DCA=YES,	X
0003			FEATURES=(OPCOM,OUTDELV),GAWAKE=YES,DCPLOAD=YES	
0004		BUFFERS	200,128,5,ARP=150,	X
0005			UDUCT=(100,28,2),	X
0006			LINKPAK=(80,280,8),RTIMER=10	
0007		CUP1	LOCAP TYPE=(STDMCP),LOW=MAIN,MEDIUM=MAIN,HIGH=MAIN	
0008		STDA	LOCAP TYPE=(STDMCP),LOW=MAIN,MEDIUM=MAIN,HIGH=MAIN	
0009		STDB	LOCAP TYPE=(STDMCP),LOW=MAIN,MEDIUM=MAIN,HIGH=MAIN	

Figure A-8. OS/3 ICAM Macros for Host C in Example Configuration 3 (Part 1 of 5)

UNISYS OS/3 SYSTEM GENERATION PARAMETER PROCESSOR				
RELEASE VERSION I12.0.0		DATE 88/09/18	TIME 17:00:35	PAGE 002
CARD	ERROR	PHASE	CONFIGURATION PARAMETER	DIAGNOSTIC
0010		NOD2	LOCAP TYPE=(DMI), IAS=(YES,OFF), MODE=SYSTEM,	X
0011			LOW=MAIN, MEDIUM=MAIN, HIGH=MAIN	
0012		IMS1	LOCAP TYPE=(TCI), LOW=MAIN	
0013		IMS2	LOCAP TYPE=(TCI), LOW=MAIN	
0014		LNE4	LINE DEVICE=(RWS),	X
0015			TYPE=(9600, SYNC),	X
0016			ID=08, CHAN=15, RETRY=(6,6), INPUT=(YES)	
0017			PGROUP PGID=27	
0018		DLG1	TERM ADDR=(27,57), FEATURES=(U20,,, PRIMARY),	X
0019			LOW=MAIN, MEDIUM=MAIN, HIGH=MAIN	
0020		DLG2	TERM ADDR=(27,58), FEATURES=(U20,,, SECONDARY),	X
0021			LOW=MAIN, MEDIUM=MAIN, HIGH=MAIN	
0022		SIL1	TERM ADDR=(27,59), FEATURES=(U20,,, PRIMARY), AUX1=(COP,73),	X
0023			LOW=MAIN, MEDIUM=MAIN, HIGH=MAIN	
0024		SIL2	TERM ADDR=(27,5A), FEATURES=(U20,,, SECONDARY), AUX1=(COP,73),	X
0025			LOW=MAIN, MEDIUM=MAIN, HIGH=MAIN	
0026		LC12	LINE DEVICE=(LWS), LBL=1024	
0027		WC12	TERM ADDR=(C12), FEATURES=(U20),	X
0028			LOW=MAIN, MEDIUM=MAIN, HIGH=MAIN	
0029		LC18	LINE DEVICE=(LWS), LBL=1024	
0030		WC18	TERM ADDR=(C18), FEATURES=(U40),	X
0031			LOW=MAIN, MEDIUM=MAIN, HIGH=MAIN	
0032		PRC1	PRCS LOW=MAIN	
0033		PRC2	PRCS LOW=MAIN	

Figure A-8. OS/3 ICAM Macros for Host C in Example Configuration 3 (Part 2 of 5)

Example Configurations

UNISYS OS/3 SYSTEM GENERATION PARAMETER PROCESSOR				
RELEASE VERSION I12.0.0		DATE 88/09/18	TIME 17:00:35	PAGE 003
CARD	ERROR	PHASE	CONFIGURATION PARAMETER	DIAGNOSTIC
0034		PRC3	PRCS LOW=MAIN	
0035		PRC4	PRCS LOW=MAIN	
0036		SESSION	EU1=(PRC1),EU2=(IMS1)	
0037		SESSION	EU1=(PRC2),EU2=(IMS1)	
0038		SESSION	EU1=(PRC3),EU2=(IMS2)	
0039		SESSION	EU1=(PRC4),EU2=(IMS2)	
0040		CHN1	DCPCHNL CNID=7, ID=12, REMOTE=DBBD	
0041		*		
0042		*	HOST TO HOST LPORT STATEMENTS	
0043		*		
0044			LPORT LINE=CHN1, PORT=64, EU1=NOD2, EU2=UNXH, USERTP=DMI,	X
0045			REMOTE=UXO3	
0046			LPORT LINE=CHN1, PORT=81, EU1=NOD2, EU2=DMI1, USERTP=DMI,	X
0047			REMOTE=BBL1	
0048		*		
0049		*	HOST TO TELCON TERMINAL LPORT STATEMENTS	
0050		*		
0051			LPORT LINE=CHN1, PORT=63, EU1=NOD2, USERTP=DMI,	X
0052			REMOTE=DBBD	
0053			LPORT LINE=CHN1, PORT=60, EU1=CUP1, USERTP=STDMCP,	X
0054			REMOTE=DBBD	
0055			LPORT LINE=CHN1, PORT=61, EU1=STDA, USERTP=STDMCP,	X
0056			REMOTE=DBBD	
0057			LPORT LINE=CHN1, PORT=62, EU1=STDB, USERTP=STDMCP,	X
0058			REMOTE=DBBD	
0059			LPORT LINE=CHN1, PORT=65, EU1=IMS1, USERTP=TC1,	X
0060			REMOTE=DBBD	

Figure A-8. OS/3 ICAM Macros for Host C in Example Configuration 3 (Part 3 of 5)

UNISYS OS/3 SYSTEM GENERATION PARAMETER PROCESSOR				
RELEASE VERSION I12.0.0 DATE 88/09/18 TIME 17:00:35 PAGE 004				
CARD	ERROR	PHASE	CONFIGURATION PARAMETER	DIAGNOSTIC
0061			LPORT LINE=CHN1,PORT=66,EU1=IMS2,USERTP=TCI,	X
0062			REMOTE=DBBD	
0063		*		
0064		*	REMOTE LOCAPS	
0065		*		
0066		UNXH	LOCAP TYPE=(DMI),LOW=MAIN,MEDIUM=MAIN,REMOTE=(UXO3)	
0067		DMI1	LOCAP TYPE=(DMI),LOW=MAIN,MEDIUM=MAIN,REMOTE=(BBL1)	
0068		*		
0069		*	REMOTE TELCON TERMINALS	
0070		*		
0071		BA05	TERM FEATURES=(U20,1920),DVCGID=INT33,LOW=MAIN,	X
0072			MEDIUM=MAIN,HIGH=MAIN,REMOTE=(DBBD),INPUT=YES,	X
0073			PROTYP=INT-1	
0074		BA06	TERM FEATURES=(U20,1920),DVCGID=INT33,LOW=MAIN,	X
0075			MEDIUM=MAIN,HIGH=MAIN,REMOTE=(DBBD),INPUT=YES,	X
0076			PROTYP=INT-1	
0077		BA07	TERM FEATURES=(U20,1920),DVCGID=INT33,LOW=MAIN,	X
0078			MEDIUM=MAIN,HIGH=MAIN,REMOTE=(DBBD),INPUT=YES,	X
0079			PROTYP=INT-1,AUX1=(COP,73)	
0080		BA08	TERM FEATURES=(U20,1920),DVCGID=INT33,LOW=MAIN,	X
0081			MEDIUM=MAIN,HIGH=MAIN,REMOTE=(DBBD),INPUT=YES,	X
0082			PROTYP=INT-1,AUX1=(COP,73),PSEUDO=TERM23	
0083			ENDCCA	
0084			MCP MCPNAME=C3	
0085			CACH=(13,BB06,1)	
0086			CACH=(08,BB06,2)	
0087			CACH=(12,,DCPCHNL)CHAN=7	
0088		END		

Figure A-8. OS/3 ICAM Macros for Host C in Example Configuration 3 (Part 4 of 5)

Example Configurations

```
UNISYS OS/3 SYSTEM GENERATION PARAMETER PROCESSOR

RELEASE VERSION I12.0.0   DATE 88/09/18   TIME 17:00:35   PAGE 005

CARD  ERROR  PHASE  CONFIGURATION PARAMETER          DIAGNOSTIC

***** SYSRES CONFIGURATION SUMMATION *****

          ICAM OUTPUT VOLUME = REL120

** SUPERVISORS **          ** COMMUNICATIONS **          ** NTRS **

          C3

SYSTEM GENERATION JOB STREAM SEQUENCE

1  RV  SG$COMMK

-  SDI  MUST BE RUN WHEN ADDING OR CHANGING THE MICROCODE ON A LOADABLE DEVICE

END OF REPORT
```

Figure A-8. OS/3 ICAM Macros for Host C in Example Configuration 3 (Part 5 of 5)

Figure A-9 shows the OS/3 ICAM macros for Host A in Example Configuration 3.

UNISYS OS/3 SYSTEM GENERATION PARAMETER PROCESSOR				
RELEASE VERSION I12.0.0 DATE 88/09/18 TIME 17:00:35 PAGE 001				
CARD	ERROR	PHASE	CONFIGURATION PARAMETER	DIAGNOSTIC
0001		COMMCT		
0002		BBL1	CCA TYPE=(GBL,,OS3A),DCA=YES,	X
0003			FEATURES=(OPCOM,OUTDELV),GAWAKE=YES	
0004			BUFFERS 200,128,5,ARP=150,	X
0005			UDUCT=(20,28,2),	X
0006			LINKPAK=(80,280,8),RTIMER=10	
0007		*		
0008		STD1	LOCAP TYPE=(STDMCP),LOW=MAIN,MEDIUM=MAIN,HIGH=MAIN	
0009		MAP1	LOCAP TYPE=(STDMCP),LOW=MAIN,MEDIUM=MAIN,HIGH=MAIN	
0010		DMI1	LOCAP TYPE=(DMI),IAS=(YES,OFF),	X
0011			LOW=MAIN,MEDIUM=MAIN,HIGH=MAIN	
0012		*		
0013		TCI1	LOCAP TYPE=(TCI),LOW=MAIN	
0014		*		
0015		VLN1	VLINE DEVICE=(ABM,DCA2),TYPE=(56000),K=1,ID=12,	X
0016			CMDADDR=3,RSPADDR=1,CHAN=15	
0017		*		
0018		*	HOST TO HOST LPORT STATEMENTS	
0019		*		
0020		LPORT	LINE=VLN1,PORT=59,EU1=DMI1,EU2=UNXH,USERTP=DMI,	X
0021			REMOTE=UXO3	
0022		LPORT	LINE=VLN1,PORT=77,EU1=DMI1,EU2=NOD2,USERTP=DMI,	X
0023			REMOTE=BB06	
0024		*		
0025		*	HOST TO TELCON TERMINAL LPORT STATEMENTS	
0026		*		
0027			LPORT LINE=VLN1,PORT=55,EU1=DMI1,USERTP=DMI,	X
0028			REMOTE=DBBD	
0029			LPORT LINE=VLN1,PORT=56,EU1=STD1,USERTP=STDMCP,	X
0030			REMOTE=DBBD	
0031			LPORT LINE=VLN1,PORT=57,EU1=MAP1,USERTP=STDMCP,	X
0032			REMOTE=DBBD	

Figure A-9. OS/3 ICAM Macros for Host A in Example Configuration 3 (Part 1 of 3)

Example Configurations

UNISYS OS/3 SYSTEM GENERATION PARAMETER PROCESSOR				
RELEASE VERSION I12.0.0 DATE 88/09/18 TIME 17:00:35 PAGE 002				
CARD	ERROR	PHASE	CONFIGURATION PARAMETER	DIAGNOSTIC
0033			LPORT LINE=VLN1,PORT=58,EU1=TCI1,USERTP=TCI,	X
0034			REMOTE=DBBD	
0035		*		
0036		*	REMOTE LOCAPS	
0037		*		
0038		UNXH	LOCAP TYPE=(DMI),LOW=MAIN,MEDIUM=MAIN,HIGH=MAIN,REMOTE=(UX03)	
0039		NOD2	LOCAP TYPE=(DMI),LOW=MAIN,MEDIUM=MAIN,HIGH=MAIN,REMOTE=(CBB06)	
0040		*		
0041		*	REMOTE TELCON TERMINALS	
0042		*		
0043		BA05	TERM FEATURES=(U20,1920),DVCGID=INT33,LOW=MAIN,	X
0044			MEDIUM=MAIN,HIGH=MAIN,REMOTE=(DBBD),INPUT=YES,	X
0045			PROTYP=INT-1	
0046		BA06	TERM FEATURES=(U20,1920),DVCGID=INT33,LOW=MAIN,	X
0047			MEDIUM=MAIN,HIGH=MAIN,REMOTE=(DBBD),INPUT=YES,	X
0048			PROTYP=INT-1	
0049		BA07	TERM FEATURES=(U20,1920),DVCGID=INT33,LOW=MAIN,	X
0050			MEDIUM=MAIN,HIGH=MAIN,REMOTE=(DBBD),INPUT=YES,	X
0051			PROTYP=INT-1,AUX1=(COP,73)	
0052		BA08	TERM FEATURES=(U20,1920),DVCGID=INT33,LOW=MAIN,	X
0053			MEDIUM=MAIN,HIGH=MAIN,REMOTE=(DBBD),INPUT=YES,	X
0054			PROTYP=INT-1,AUX1=(COP,73),PSEUDO=TERM23	
0055			ENDCCA	
0056		*		
0057			MCP MCPNAME=C2	
0058			CACH=(12,56000,FULL,ILA),CHAN=15	
0059		END		

Figure A-9. OS/3 ICAM Macros for Host A in Example Configuration 3 (Part 2 of 3)

UNISYS OS/3 SYSTEM GENERATION PARAMETER PROCESSOR

RELEASE VERSION 112.0.0 DATE 88/09/18 TIME 17:00:35 PAGE 003

CARD ERROR PHASE CONFIGURATION PARAMETER DIAGNOSTIC

***** SYSRES CONFIGURATION SUMMATION *****

ICAM OUTPUT VOLUME = REL120

** SUPERVISORS **

** COMMUNICATIONS **

** NTRS **

C2

NO ERRORS

SYSTEM GENERATION JOB STREAM SEQUENCE

1 RV SG\$COMMK

END OF REPORT

Figure A-9. OS/3 ICAM Macros for Host A in Example Configuration 3 (Part 3 of 3)

Example Configurations

UNIX Configuration (Host B)

The following are the UNIX parameters required for Host B to support Example Configuration 3.

Local UNIX Parameters

SDLC address: 8A

Matches RSA= on Telcon STATION statement named STAUNIX.

OWN HOST ID: UNXH

Matches ICAM remote LOCAP name in BBL1 and **BB06** CCA.

Remote Host ID/Logical Channel Definitions

DMI1/75

DMI1 matches ICAM local LOCAP name in BBL1 CCA; 75 matches TS1 *lsch* on Telcon SESSN statement UNX1BBL1.

NOD2/76

NOD2 matches ICAM local LOCAP name in BB06 CCA; 76 matches TS1 *lsch* on Telcon SESSN statement UNX1BB06.

Note: If DDP is not used within the DCP, there is no requirement for the DCATS name (UXO3) in TS1 to be the same as the DDP host ID (UNXH).

Refer to the *DIS/5000 User Guide* (UP-11816) for details on UNIX - Telcon host configuration.

Figure A-10 shows the Telcon statements that correspond to the OS/3 macros for Hosts A and C and the UNIX parameters for Host B in Example Configuration 3.

```

TELVS9*NETWORK(1).DEB1(0)
1 *****
2 *
3 * PRCSR (PROCESSORS)
4 *
5 *****
6 *
7 BBD PRCSR DSPL=ALL,LOGL=ALL,NMSR='RSC',NMSU=('RSC',144,,10),;
8 STATS=(LINE,30)
9 *
10 *****
11 *
12 * DCPTS (DCP TERMINATION SYSTEMS)
13 *
14 *****
15 *
16 DBBD DCPTS PRCSR=BBD
17 *
18 *****
19 *
20 * DCATS (DCA TERMINATION SYSTEMS)
21 *
22 *****
23 BB06 DCATS PRCSR=BBD *OS3-M1
24 BBL1 DCATS PRCSR=BBD *OS3-L1
25 UX03 DCATS PRCSR=BBD *OS3-UNIX
26 *****
27 * OS3 SYSTEM L1 XEUS AND SESSIONS *
28 *****
29 DMI1 XEU TS=BBL1,DESTSSU='DMI1',DPP=INT1
30 STD1 XEU TS=BBL1,DESTSSU='STD1',DPP=INT1
31 MAP1 XEU TS=BBL1,DESTSSU='MAP1',DPP=INT1
32 TCI1 XEU TS=BBL1,DESTSSU='TCI1',DPP=INT1
33 *
34 *
35 DMI1BBL1 SESSN TS1=(DBBD,55,BBD),TS2=(BBL1,55,BBD)
36 STD1BBL1 SESSN TS1=(DBBD,56,BBD),TS2=(BBL1,56,BBD)
37 MAP1BBL1 SESSN TS1=(DBBD,57,BBD),TS2=(BBL1,57,BBD)
38 TCI1BBL1 SESSN TS1=(DBBD,58,BBD),TS2=(BBL1,58,BBD)
39 *****
40 * OS3 SYSTEM M1 (BB06) XEUS AND SESSIONS *
41 *****
42 CUP1 XEU TS=BB06,DESTSSU='CUP1',DPP=INT1
43 STDA XEU TS=BB06,DESTSSU='STDA',DPP=INT1
44 STDB XEU TS=BB06,DESTSSU='STDB',DPP=INT1
45 NOD2 XEU TS=BB06,DESTSSU='NOD2',DPP=INT1

```

Figure A-10. Telcon Statements for Example Configuration 3 (Part 1 of 3)

Example Configurations

```

46 IMS1 XEU TS=BB06,DESTSSU='IMS1',DPP=INT1
47 IMS2 XEU TS=BB06,DESTSSU='IMS2',DPP=INT1
48 *
49 *
50 CUP1BB06 SESSN TS1=(DBBD,60,BBD),TS2=(BB06,60,BBD)
51 STDAB06 SESSN TS1=(DBBD,61,BBD),TS2=(BB06,61,BBD)
52 STDDB06 SESSN TS1=(DBBD,62,BBD),TS2=(BB06,62,BBD)
53 NOD2BB06 SESSN TS1=(DBBD,63,BBD),TS2=(BB06,63,BBD)
54 IMS1BB06 SESSN TS1=(DBBD,65,BBD),TS2=(BB06,65,BBD)
55 IMS2BB06 SESSN TS1=(DBBD,66,BBD),TS2=(BB06,66,BBD)
56 *****
57 * HOST TO HOST SESSIONS *
58 *****
59 BBL1BB06 SESSN TS1=(BBL1,77,BBD),TS2=(BB06,81,BBD)
60 UNIXBBL1 SESSN TS1=(UXO3,75,BBD),TS2=(BBL1,59,BBD)
61 UNIX1BB06 SESSN TS1=(UXO3,76,BBD),TS2=(BB06,64,BBD)
62 *****
63 * CLASS COMMUNICATION LINES/Common CHARACTERISTICS *
64 * *
65 *****
66 UN96D LCLASS LPH=U100L,SPEED=9600,OPTIONS=(DIR,SYHD)
67 UNIX92 LCLASS LPH=UDLCL,SPEED=2400,OPTIONS=(DIR,SYHD)
68 UDLC560 LCLASS LPH=UDLCL,SPEED=64000
69 *****
70 LBD32 LINE PRCSR=BBD,CLASS=UDLC560,ADR=X'032' * OS3 L1 SYSTEM
71 LBD02 LINE PRCSR=BBD,CLASS=UNIX92,ADR=X'02' * UNIX SYSTEM
72 CHBB06 CHANNEL TS=BB06,CPID=X'0D'
73
74 *****
75 * UDLC STATION BBD TO ALL OS3-NET SYSTEMS *
76 *****
77 *
78 STAL1 STATION LINE=LBD32,RSHLE=BBL1,MODE=ABM,LSA=3,RSA=1 * SYS L1
79 STAUNIX STATION LINE=LBD02,RSHLE=UXO3,MODE=NRM,LSTYP=PRIM,RSA=08A
80 *****
81 * MUX LINE DEFINITION STATEMENTS *
82 *****
83 LBD2D LINE PRCSR=BBD,CLASS=UN96D,ADR=02D
84 *****
85 * MUX GROUP DEFINITION STATEMENTS *
86 *****
87 GP2D GROUP PRCSR=BBD,LINE=LBD2D

```

Figure A-10. Telcon Statements for Example Configuration 3 (Part 2 of 3)

88	*****		
89	*	TERMINAL STATEMENTS	*
90	*****		
91	BA05	TERM	GROUP=GP2D,TYPE=UTS20,ADR=(027,057)
92	BA06	TERM	GROUP=GP2D,TYPE=UTS20,ADR=(027,058)
93	BA07	TERM	GROUP=GP2D,TYPE=UTS20,ADR=(027,059)
94	BA07P1	DEVICE	TERM=BA07,TYPE=PRTR,ADR=(0,073)
95	TERM23	TERM	GROUP=GP2D,TYPE=UTS20,ADR=(027,05A)
96	TERM23P1	DEVICE	TERM=TERM23,TYPE=PRTR,ADR=(0,073)

Figure A-10. Telcon Statements for Example Configuration 3 (Part 3 of 3)

A.6.4. Example Configuration 4

Example Configuration 4 (Figure A-11) presents a small configuration of a UDLC and SU0039 CHANNEL connection between the OS/3 host and a DCP15. The DCP15 is connected to a DCP40 via a UDLC trunk.

Terminals connected to the DCP15 and DCP40 can access the OS/3 host across the VLINE or CHANNEL, depending on the \$\$OPEN name used. This is accomplished by using two Telcon DCATS statements (BM10, B10). The XEU, SESSN, STATION, and CHANNEL statements refer back to the DCATS statements. An outbound OPEN from OS/3 host to a Telcon terminal uses whichever connection (VLINE or CHANNEL) the terminal is defined from in the ICAM generation.

This configuration also shows how a dual-screen Telcon terminal (BA07, BA08) is defined in the OS/3 ICAM generation to support OS/3 terminal spooling. Nothing is required in the Telcon generation. If multiple paths (VLN1, CHN1) are used between System 80 and DCP, the path that the terminal is defined off of (CHN1) must be initialized for the terminal spooling commands to execute normally.

Another terminal (BE10, BE11) is defined in the Telcon generation to automatically sign on and open the initial session to the OS/3 DMI LOCAP (DMI8) across the CHANNEL as a result of first input at the terminal. This is accomplished by using the Telcon TERM statement with ALOC=YES and DEST=DMI8CH specified. (This is only done for the initial OPEN. Any operator \$\$OPEN overrides the defined destination.) Nothing is required in the ICAM generation.

This configuration illustrates the relationship between the TS1 and TS2 *lsch* numbers on the Telcon SESSN statements and the port numbers on the ICAM LPORT macros.

- From the Telcon DCP15 generation:

```

DMIB10    SESSN    TS1=(DBBE,1,BBE),TS2=(B10,1,BBE)
DM18BM10 SESSN    TS1=(DBBD,73,BBD),TS2=(BM10,7,BBE)
STD8BM10 SESSN    TS1=(DBBD,74,BBD),TS2=(BM10,8,BBE)
    
```

Example Configurations

- From the ICAM generation:

```

LPORT    LINE=VLN1,PORT=1,EU1=DM18,USERTP=DMI,REMOTE=DBBE
LPORT    LINE=CHN1,PORT=7,EU1=DM18,USERTP=DMI,REMOTE=DBBD
LPORT    LINE=CHN1,PORT=8,EU1=STD8,USERTP=STDMCP,REMOTE=DBBD
  
```

The ICAM *port* number matches the Telcon *lsch* number on the TS1 or TS2 parameter that refers back to the OS/3 host via the DCATS name specified as the termination system. In this example, it matches with TS2. The TS1 parameter defines the other termination system that TS2 will be in session with. In this example, it is a DCPTS defined as DBBE or DBBD and associated with a DCP processor (BBE or BBD) to which the terminals are connected. B10 or BM10 are the DCATS names that reference the OS/3 host. BBE is the DCP processor with which this OS/3 host is associated. The TS1 and TS2 *lsch* numbers have no meaning to each other within a SESSN statement. The numbers represent a logical relationship between the termination system and the associated processor within TS1 or TS2 (DBBE and BBE, B10 and BBE, DBBD and BBD, BM10 and BBE).

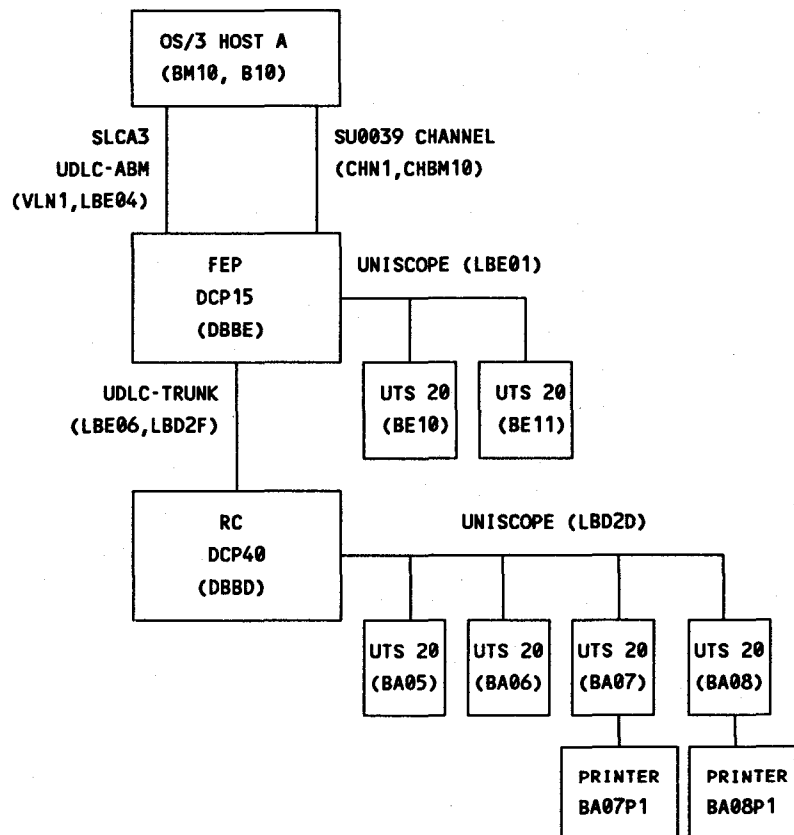

Figure A-11. Example Configuration 4

The components in Example Configuration 4 are:

- The OS/3 host computer
- One DCP15 acting as a front-end processor for the OS/3 host
- One DCP40 acting as a remote concentrator
- One dual-screen UTS 20 display terminal connected to DCP15 via a 9600-baud, direct, half-duplex UNISCOPE line
- Two dual-screen UTS 20 display terminals (one with printer) connected to DCP40 via a 9600-baud, direct, half-duplex UNISCOPE line
- One 9600-baud, direct UDLC line between host and DCP15
- One SU0039 CHANNEL between host and DCP15
- One 56,000-baud, direct UDLC line between DCP15 and DCP40

Figure A-12 shows the OS/3 ICAM macros that support Example Configuration 4.

Example Configurations

```

UNISYS OS/3 SYSTEM GENERATION PARAMETER PROCESSOR

RELEASE VERSION 12.0.0      DATE 88/06/14      TIME 09:52:31      PAGE 001

ERROR  PHASE  CONFIGURATION PARAMETER  DIAGNOSTIC

COMMCT

DCPI   CCA  TYPE=(GBL,,BM10),DCA=YES,                X
        FEATURES=(OPCOM,RESTART,OUTDELV,SEGMENTS,MONITOR),  X
        CCAID=BM10,GAWAKE=YES,SAVE=YES,DCPLOAD=YES

        BUFFERS 25,8000,5,ARP=150,                    X
        UDUCT=(20,28,2),                                X
        LINKPAK=(25,1064,2),RTIMER=15

*
*   $$OPEN NAMES ACROSS CHANNEL:  DM18CH --> DM18
*                                   STD8CH --> STD8
*                                   MAP8CH --> MAP8
*                                   TC18CH --> TC18
*
*   $$OPEN NAMES ACROSS UDLC:     DM18UD --> DM18
*                                   STD8UD --> STD8
*                                   MAP8UD --> MAP8
*                                   TC18UD --> TC18
*
STD8   LOCAP TYPE=(STDMCP),LOW=MAIN,MEDIUM=MAIN,HIGH=MAIN

MAP8   LOCAP TYPE=(STDMCP),LOW=MAIN,MEDIUM=MAIN,HIGH=MAIN

DM18   LOCAP TYPE=(DMI),IAS=(YES,OFF),                X
        LOW=MAIN,MEDIUM=MAIN,HIGH=MAIN

TC18   LOCAP TYPE=(TCI),LOW=MAIN

*
VLN1   VLINE DEVICE=(ABM,DCA2),TYPE=(9600),K=1,ID=05,    X
        CMDADDR=3,RSPADDR=1,CHAN=15

*
*   HOST TO TELCON TERMINAL (DBBD) LPORT STATEMENTS ACROSS UDLC
*
LPORT  LINE=VLN1,PORT=11,EU1=DM18,USERTP=DMI,          X
        REMOTE=DBBD

LPORT  LINE=VLN1,PORT=12,EU1=STD8,USERTP=STDMCP,       X
        REMOTE=DBBD

```

Figure A-12. OS/3 ICAM Macros for Example Configuration 4 (Part 1 of 3)

UNISYS OS/3 SYSTEM GENERATION PARAMETER PROCESSOR

RELEASE VERSION 12.0.0 DATE 88/06/14 TIME 09:52:31 PAGE 002

ERROR	PHASE	CONFIGURATION PARAMETER	DIAGNOSTIC
		LPORT LINE=VLN1,PORT=13,EU1=MAP8,USERTP=STDMCP, REMOTE=DBBD	X
		LPORT LINE=VLN1,PORT=14,EU1=TCI8,USERTP=TCI, REMOTE=DBBD	X
	*		
	*	HOST TO TELCON TERMINAL (DBBE) LPORT STATEMENTS ACROSS UDLC	
	*		
		LPORT LINE=VLN1,PORT=1,EU1=DMI8,USERTP=DMI, REMOTE=DBBE	X
		LPORT LINE=VLN1,PORT=2,EU1=STD8,USERTP=STDMCP, REMOTE=DBBE	X
		LPORT LINE=VLN1,PORT=3,EU1=TCI8,USERTP=TCI, REMOTE=DBBE	X
	*		
	CHN1	DCPCHNL CNID=7,IO=12,REMOTE=DBBE	
	*		
	*	HOST TO TELCON TERMINAL (DBBD) LPORT ACROSS DCP CHANNEL	
	*		
		LPORT LINE=CHN1,PORT=7,EU1=DMI8,USERTP=DMI, REMOTE =DBBD	X
		LPORT LINE=CHN1,PORT=8,EU1=STD8,USERTP=STDMCP, REMOTE=DBBD	X
		LPORT LINE=CHN1,PORT=9,EU1=MAP8,USERTP=STDMCP, REMOTE=DBBD	X
		LOCAP LINE=CHN1,PORT=10,EU1=TCI8,USERTP=TCI REMOTE=DBBD	X
	*		
	*	HOST TO TELCON TERMINAL (DBBE) LPORT ACROSS DCP CHANNEL	
	*		
		LPORT LINE=CHN1,PORT=4,EU1=DMI8,USERTP=DMI, REMOTE=DBBE	X
		LPORT LINE=CHN1,PORT=5,EU1=STD8,USERTP=STDMCP, REMOTE=DBBE	X

Figure A-12. OS/3 ICAM Macros for Example Configuration 4 (Part 2 of 3)

Example Configurations

UNISYS OS/3 SYSTEM GENERATION PARAMETER PROCESSOR

RELEASE VERSION 12.0.0 DATE 88/06/14 TIME 09:52:31 PAGE 003

ERROR	PHASE	CONFIGURATION PARAMETER	DIAGNOSTIC
		LPORT LINE=CHN1,PORT=6,EU1=TCI8,USERTP=TCI, REMOTE=DBBE	X
	*		
	*	REMOTE TELCON TERMINALS CONNECTED TO DCP40 - BBD	
	*		
BA05	TERM	FEATURES=(U20,1920),DVCID=INT33,LOW=MAIN, MEDIUM=MAIN,HIGH=MAIN,REMOTE=(DBBD),INPUT=YES, PROTYP=INT-1	X X
BA06	TERM	FEATURES=(U20,1920),DVCID=INT33,LOW=MAIN, MEDIUM=MAIN,HIGH=MAIN,REMOTE=(DBBD),INPUT=YES, PROTYP=INT-1	X X
BA07	TERM	FEATURES=(u20,1920,,,PRIMARY),DVCID=INT33,LOW=MAIN, MEDIUM=MAIN,HIGH=MAIN,REMOTE=(DBBD),INPUT=YES, PROTYP=INT=1,AUX1=(COP,73)	X X
BA08	TERM	FEATURES=(U20,1920,,,SECONDARY),DVCID=INT33,LOW=MAIN, MEDIUM=MAIN,HIGH=MAIN,REMOTE=(DBBD),INPUT=YES, PROTYP=INT-1,AUX1=(COP,73)	X X
	*	REMOTE TELCON TERMINALS CONNECTED TO DCP15 = BBE	
BE10	TERM	FEATURES=(U20,1920),DVCID=INT33,LOW=MAIN, MEDIUM=MAIN,HIGH=MAIN,REMOTE=(DBBE),INPUT=YES, PROTYP=INT-1	X X
BE11	TERM	FEATURES=(U20,1920),DVCID=INT33,LOW=MAIN, MEDIUM=MAIN,HIGH=MAIN,REMOTE=(DBBE),INPUT=YES, PROTYP=INT-1	X X
	*		
	*	ENDCCA	
	*		
	*	MCP MCPNAME=M5	
	*		
	*		
		CACH=(05,9600,FULL,ILA),CHAN=15 CACH=(12,,DCPCHNL),CHAN=7	
		END	

Figure A-12. OS/3 ICAM Macros for Example Configuration 4 (Part 3 of 3)

Figure A-13 shows the DCP15 (DBBE) Telcon statements that correspond to the OS/3 ICAM macros and DCP40 (DBBD) Telcon statements in Example Configuration 4.

```

BBD      PRCSR      ;                * 4-04 BLUE BELL
        DSPL=ALL,LOGL=ALL,NMSR='RSC',TIMEOUT=(60,60),;
        STATS=(LINE,30),CPUSTATS=YES,PPESTATS=YES
BBE      PRCSR      ;                * 5-05 BLUE BELL
        DSPL=ALL,LOGL=ALL,NMSR='RSC',TIMEOUT=(60,60),;
        STATS=(LINE,30),CPUSTATS=YES,PPESTATS=YES
*****
* DCPTS (DCP TERMINATION SYSTEMS) *
*****
DBBD     DCPTS      PRCSR=BBD
DBBE     DCPTS      PRCSR=BBE
*****
* DCATS (DCP TERMINATION SYSTEMS) *
*****
BM10     DCATS      PRCSR=BBE        * MOD8-OS/3 DEVELOPMENT M10
B10      DCATS      PRCSR=BBE        * MOD8-OS/3 DEVELOPMENT M10
*****
* LOCAL XEU'S ACROSS CHANNEL *
*****
DM18CH   XEU       TS=B10,DPP=INT1,DESTSSU='DM18'
STD8CH   XEU       TS=B10,DPP=INT1,DESTSSU='STD8'
MAP8CH   XEU       TS=B10,DPP,INT1,DESTSSU='MAP8'
TC18CH   XEU       TS=B10,DPP,INT1,DESTSSU='TC18'
*****
* LOCAL XEU'S ACROSS UDLC *
*****
DM18UD   XEU       TS=BM10,DPP=INT1,DESTSSU='DM18'
STD8UD   XEU       TS=BM10,DPP=INT1,DESTSSU='STD8'
MAP8UD   XEU       TS=BM10,DPP,INT1,DESTSSU='MAP8'
TC18UD   XEU       TS=BM10,DPP,INT1,DESTSSU='TC18'
*****
* SESSIONS FROM BBE ACROSS CHANNEL *
*****
DM1BM10  SESSN     TS1=(DBBE,4,BBE),TS2=(BM10,4,BBE)
STDBM10  SESSN     TS1=(DBBE,5,BBE),TS2=(BM10,5,BBE)
TC1BM10  SESSN     TS1=(DBBE,6,BBE),TS2=(BM10,6,BBE)
*****
* SESSIONS FROM BBE ACROSS UDLC *
*****
DM1B10   SESSN     TS1=(DBBE,1,BBE),TS2=(B10,1,BBE)
STDB10   SESSN     TS1=(DBBE,2,BBE),TS2=(B10,2,BBE)
TC1B10   SESSN     TS1=(DBBE,3,BBE),TS2=(B10,3,BBE)

```

Figure A-13. DCP15 Telcon Statements for Example Configuration 4 (Part 1 of 2)

Example Configurations

```

*****
*                               SESSIONS FROM BBD ACROSS CHANNEL                               *
*****
DMI8BM10  SESSN    TS1=(DBBD,73,BBD),TS2=(BM10,7,BBE)
STD8BM10  SESSN    TS1=(DBBD,74,BBD),TS2=(BM10,8,BBE)
MAP8BM10  SESSN    TS1=(DBBD,75,BBD),TS2=(BM10,9,BBE)
TCI8BM10  SESSN    TS1=(DBBD,76,BBD),TS2=(BM10,10,BBE)
*****
*                               SESSIONS FROM BBD ACROSS UDLC                               *
*****
DMI8B10   SESSN    TS1=(DBBD,40,BBD),TS2=(B10,11,BBE)
STD8B10   SESSN    TS1=(DBBD,41,BBD),TS2=(B10,12,BBE)
MAP8B10   SESSN    TS1=(DBBD,42,BBD),TS2=(B10,13,BBE)
TCI8B10   SESSN    TS1=(DBBD,43,BBD),TS2=(B10,14,BBE)
*****
*                               LCLASS STATEMENTS                                         *
*****
UDL96FDX  LCLASS  LPH=UDLCL,SPEED=9600,OPTIONS=(DIR,SYFD)
UDLC560   LCLASS  LPH=UDLCL,SPEED=64000
UN96D     LCLASS  LPH=U100L,SPEED=9600
*****
*                               LINE STATEMENTS                                           *
*****
LBE01     LINE     PRCSR=BBE,CLASS=UN96D,ADR=X'01' TERMINAL USE
LBE04     LINE     PRCSR=BBE,CLASS=UDL96FDX,ADR=X'04' * TO BM10
LBE06     LINE     TRUNK=TBEBBD,CLASS=UDLC560,ADR=X'06' * TO BBD 2F
CHBM10    CHANNEL  TS=BM10,PPID=X'0D'
*****
*                               STATION STATEMENTS                                       *
*****
STBE04    STATION  LINE=LBE04,RSHLE=B10,MODE=ABM,LSA=3,RSA=1
SBBEBBD   STATION  LINE=LBE06,RSHLE=TBEBBD
*****
*                               GROUP STATEMENTS                                         *
*****
GP01      GROUP   PRCSR=BBE,LINE=LBE01
*****
*                               LINE LBE01                                             *
*****
BE10      TERM    GROUP=GP01,TYPE=UTS20,ADR=(021,051),ALOC=YES,DEST=DMI8CH
BE10PR    DEVICE  TERM=BE10,TYPE=PRTR,ADR=(0,073)
BE11      TERM    DUALSCRN=BE10

```

Figure A-13. DCP15 Telcon Statements for Example Configuration 4 (Part 2 of 2)

Figure A-14 shows the DCP40 (DBBD) Telcon statements that correspond to the OS/3 ICAM macros and the DCP15 (DBBE) Telcon statements in Example Configuration 4.

```

BBD      PRCSR      ;                      * 4-04  BLUE BELL
        DSPL=ALL,LOGL=ALL,NMSR='RSC',TIMEOUT=(60,60),;
        STATS=(LINE,30),CPUSTATS=YES,PPESTATS=YES
BBE      PRCSR      ;                      * 5-05  BLUE BELL
        DSPL=ALL,LOGL=ALL,NMSR='RSC',TIMEOUT=(60,60),;
        STATS=(LINE,30),CPUSTATS=YES,PPESTATS=YES
*****
* DCPTS (DCP TERMINATION SYSTEMS)
*****
DBBD     DCPTS      PRCSR=BBD
DBBE     DCPTS      PRCSR=BBE
*****
* DCATS (DCP TERMINATION SYSTEMS)
*****
BM10     DCATS      PRCSR=BBE      * MOD8-OS/3 DEVELOPMENT M10
B10      DCATS      PRCSR=BBE      * MOD8-OS/3 DEVELOPMENT M10
*****
* LOCAL XEUS FOR BM10 ACROSS CHANNEL
*****
DMI8CH   XEU      TS=BM10,DESTSSU='DMI8',DPP=INT1
STD8CH   XEU      TS=BM10,DESTSSU='STD8',DPP=INT1
MAP8CH   XEU      TS=BM10,DESTSSU='MAP8',DPP=INT1
TCI8CH   XEU      TS=BM10,DESTSSU='TCI8',DPP=INT1
*****
* LOCAL XEUS FOR B10 ACROSS UDLC
*****
DMI8UD   XEU      TS=B10,DESTSSU='DMI8',DPP=INT1
STD8UD   XEU      TS=B10,DESTSSU='STD8',DPP=INT1
MAP8UD   XEU      TS=B10,DESTSSU='MAP8',DPP=INT1
TCI8UD   XEU      TS=B10,DESTSSU='TCI8',DPP=INT1
*****
* SESSIONS FROM BBD ACROSS CHANNEL
*****
DMI8BM10 SESSN     TS1=(DBBD,73,BBD),TS2=(BM10,7,BBE)
STD8BM10 SESSN     TS1=(DBBD,74,BBD),TS2=(BM10,8,BBE)
MAP8BM10 SESSN     TS1=(DBBD,75,BBD),TS2=(BM10,9,BBE)
TCI8BM10 SESSN     TS1=(DBBD,76,BBD),TS2=(BM10,10,BBE)
*****
* SESSIONS FROM BBD ACROSS UDLC
*****
DMI8B10  SESSN     TS1=(DBBD,40,BBD),TS2=(B10,11,BBE)
STD8B10  SESSN     TS1=(DBBD,41,BBD),TS2=(B10,12,BBE)
MAP8B10  SESSN     TS1=(DBBD,42,BBD),TS2=(B10,13,BBE)
TCI8B10  SESSN     TS1=(DBBD,43,BBD),TS2=(B10,14,BBE)

```

Figure A-14. DCP40 Telcon Statements for Example Configuration 4 (Part 1 of 2)

Example Configurations

```
*****
*          CLASS OF COMMUNICATION LINES/Common CHARACTERISTICS          *
*****
UN96D   LCLASS LPH=U100L,SPEED=9600,OPTIONS=(DIR,SYHD)
UDDL560 LCLASS LPH=UDLCL,SPEED=64000
*****
*          UDLC LINES FROM BBD TO BBE          *
*****
LBD2F   LINE TRUNK=TBDBBE,CLASS=UDLC560,ADR=X'2F' * ADR=X'06' DCP15
*****
*          UDLC STATION BBD TO BBE          *
*****
STBDBBE STATION LINE=LBD2F,RSHLE=TBDBBE * BBDBBE
*****
*          MUX LINE, GROUP, AND TERM DEFINITION STATEMENTS          *
*****
LBD2D   LINE  PRCSR=BBB,CLASS=UN96D,ADR=02D
*****
GP2D    GROUP PRCSR=BBB,LINE=LBD2D
*
BA05    TERM  GROUP=GP2D,TYPE=UTS20,ADR=(027,057)
BA06    TERM  GROUP=GP2D,TYPE=UTS20,ADR=(027,058)
BA07    TERM  GROUP=GP2D,TYPE=UTS20,ADR=(027,059)
BA07P1  DEVICE TERM=BA07,TYPE=PRTR,ADR=(0,073)
BA08    TERM  GROUP=GP2D,TYPE=UTS20,ADR=(027,05A)
BA08P1  DEVICE TERM=BA08,TYPE=PRTR,ADR=(0,073)
```

Figure A-14. DCP40 Telcon Statements for Example Configuration 4 (Part 2 of 2)

A.7. General Comments

A.7.1. OS/3 ICAM Static Sessions

ICAM global DCA networks require dynamic sessions. These sessions can be made to seem static for users accustomed to having ICAM static sessions by defining the terminals in the Telcon configuration as auto-allocated and specifying the destination. Refer to the Telcon TERM statement (ALOC and DEST parameters) in the current version of the *OS 1100/DCP Series, Communications Delivery Software, Configuration Guide* (UP-9957). This configuration permits the initial session to be established without the operator having to sign on or \$\$OPEN.

A.7.2. VLINEs

If the VLINE connecting the OS/3 host to the DCP goes down, it must be brought back up manually.

If the VLINE link is not established at initialization time, check to see if CMDADDR and RSPADDR match with Telcon LSA and RSA on the STATION macro.

A.7.3. Multiple Paths between System 80 and DCP

Multiple paths (two UDLC links, etc.) can be configured between a system 80 and a DCP.

Depending on the \$\$OPEN used at the Telcon terminal, a session is made across the desired path. The System 80 does not care which VLINE or DCPCHNL defines the remote terminal.

If a session is to be made from a System 80 to a Telcon terminal (outbound open), the VLINE or DCPCHNL to which the remote terminal is defined will be the path used. There is no choice.

A.7.4. OS/3 Terminal Spooling

If multiple paths are used between System 80 and DCP, the VLINE or DCPCHNL to which the remote terminal is defined must be active and up. If not initialized, the result of the terminal spooling command will be an error message displayed on screen1 (RP03 aux device not available).

A.8. Additional Documentation

You will need additional manuals to configure Telcon and ICAM networks. The following are some of these manuals; you can order them through your representative. They also contain references to other related documents.

Note: *If you are installing release 7 of Telcon, order the appropriate equivalents of required manuals to support Telcon 7 and above.*

- *OS 1100/DCP Series, Communications Delivery Software, Configuration Guide (UP-9957)*

Tells how to install a communication network and configure it for your particular network.

- *OS 1100/DCP Series, Communications Delivery Software, Installation Guide (UP-9956)*

Tells how to install, generate, and verify CMS 1100 and Telcon. Pairs with the Configuration Guide to provide complete information for configuring/installing a communication network in CMS 1100/Telcon.

- *OS 1100/DCP Series, Communications Delivery Software, Software Release Description (UP-10726)*

Accompanies the CMS 1100 and Telcon tape shipped to customers. Describes all improvements and changes since the previous release of CMS 1100 and Telcon.

Appendix B

Configuring UTS 20/40/400 Terminals

The following examples illustrate how to use the U400..., U20 ..., and U40 ... suboperands of the TERM macroinstruction. The material in this appendix supplements the information presented in 2.25 for the TERM macro.

The UTS 20 and UTS 40 terminals have a dual screen capability and may be configured as standard terminals or as remote workstations.

B.1. Terminal Configurations

Specify DEVICE=(UNISCOPE) in the LINE macro for the communication line that supports the terminal.

- The following shows how to specify a UTS 400 terminal with screen bypass feature for a communications output printer (COP). The COP printer is physically connected to the controller but can be accessed either through the UTS 400 (TRM1) or directly as a screen bypass terminal (TRM2). The COP printer is physically connected to the controller.

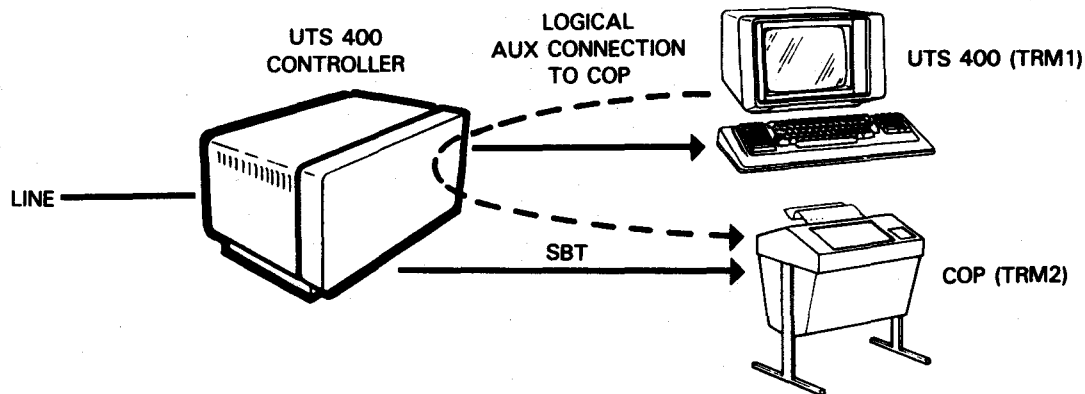

TRM1	TERM	FEATURES=(U400, 1920), ADDR=(28, 51), AUX1=(COP, 73), LOW=MAIN, MEDIUM=MAIN, HIGH=MAIN	X
TRM2	TERM	FEATURES=(U400, , SBT), ADDR=(28, 52), AUX1=(COP, 73) LOW=MAIN, MEDIUM=MAIN, HIGH=MAIN	X

Configuring UTS 20/40/400 Terminals

- UTS 20 single station with terminal printer (TP) auxiliary Device:

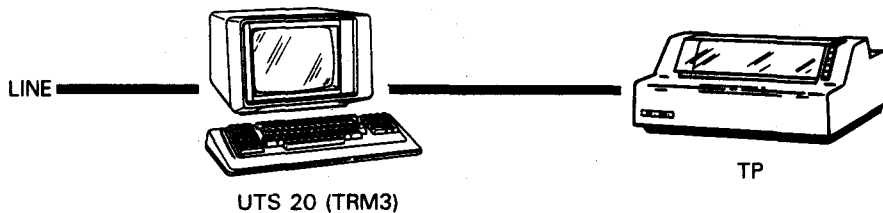

```
TRM3 TERM FEATURES=(U20,1920),ADDR=(21,51),AUX1=(TP,73),      X
LOW=MAIN
```

- The following shows two UTS 20W workstations and an 8406 diskette subsystem attached to a cluster controller. Also, a communications output printer (COP) and a terminal printer (TP) are connected to the terminals. A screen bypass feature is installed in terminal TRM5.

The TRM4 definition specifies there is a COP printer attached to the terminal with a device identifier (did) of 73.

The TRM5 definition specifies the TP is accessed as AUX1. A diskette subsystem has two drives. Each disk drive requires two dids, one for reading and one for writing, in this case identified as sids 75, 76, 77, 78. A program accesses each drive function as an auxiliary device, e.g., AUX2, AUX3, AUX4, and AUX5 respectively. Access to the diskette is through the TRM5 display screen.

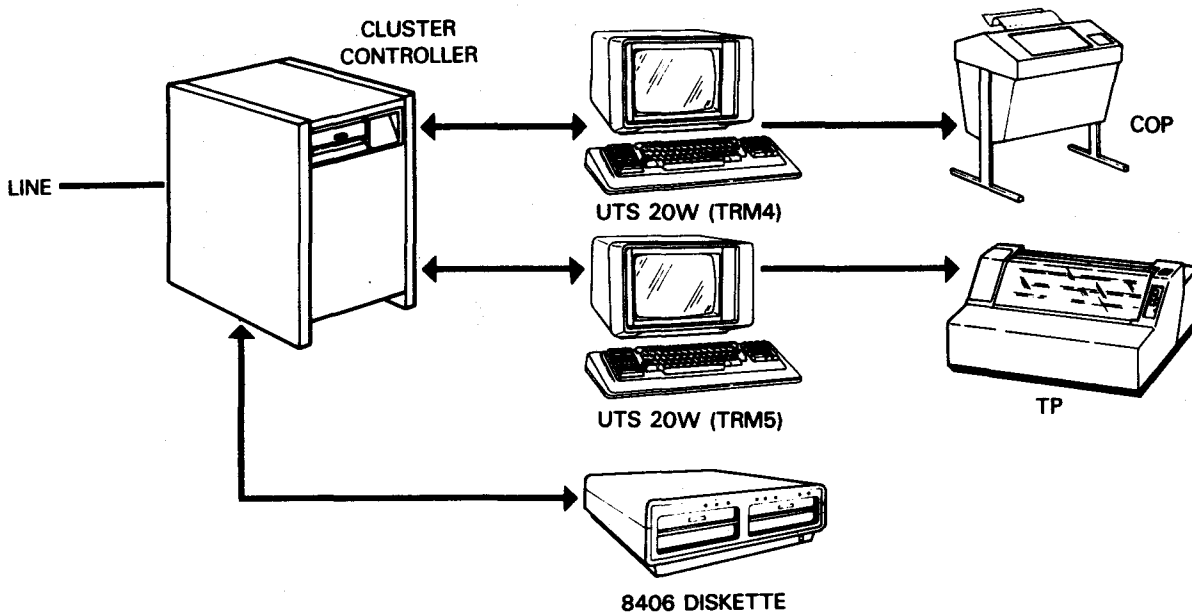

```

TRM4 TERM FEATURES=(U20,1920,,CC)ADDR=(29,51), X
      AUX1=(COP,73),LOW=MAIN,MEDIUM=MAIN
TRM5 TERM FEATURES=(U20,1920,SBT,CC),ADDR=(29,52), X
      AUX1=(TP,73),AUX2(TCS,75,76),AUX4=(TCS,77,78), X
      LOW=MAIN,MEDIUM=MAIN
    
```

- The following shows a UTS 20 single station equipped with a screen bypass feature. This feature allows your program to write to the terminal printer (TP) or to the communications output printer via TRM7 while the terminal operator concurrently uses the display screen to enter and receive data. Your program communicates with the screen via TRM6.

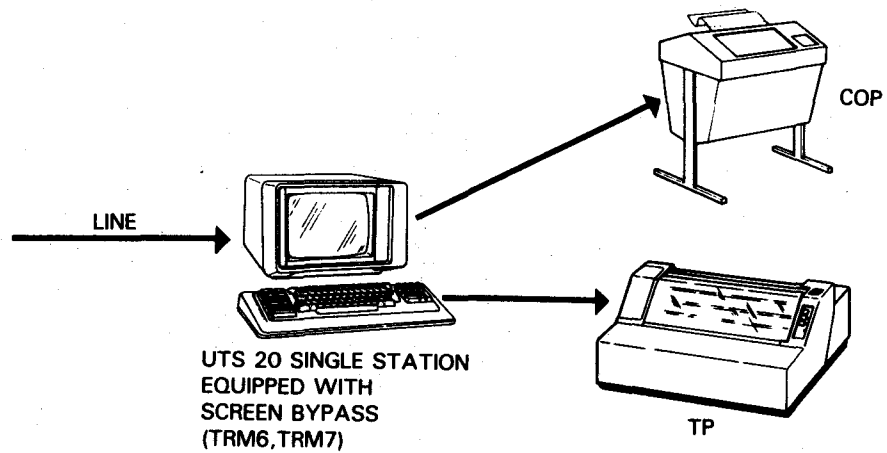

```

TRM6 TERM FEATURES=(U20,1920,,),ADDR=(30,51),LOW=MAIN
TRM7 TERM FEATURES=(U20,1920,SBT),ADDR=(30,52), X
      AUX1=(TP,73),AUX2=(COP,74),LOW=MAIN
    
```

Configuring UTS 20/40/400 Terminals

- This example shows how to define a UTS 40 single station terminal with a terminal printer:

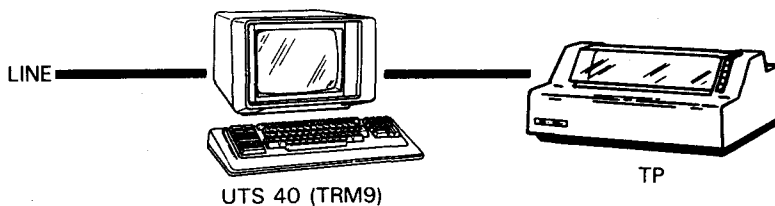

```
TRM9 TERM FEATURES=(U40,1920),AUX1=(TP,73),
      LOW=MAIN,MEDIUM=MAIN,HIGH=MAIN X
```

- This example shows how to define a UTS 40 single station terminal with a dual screen and terminal printer:

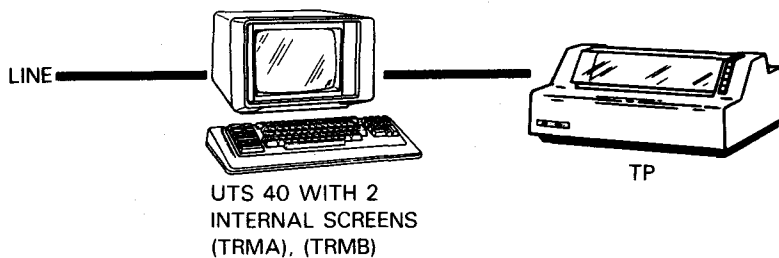

Notice that two **TERM** macros are required, one for each display screen.

```
TRMA TERM FEATURES=(U40,1920),ADDR=(31,51),
      AUX1=(TP,73),LOW=MAIN,MEDIUM=MAIN,HIGH=MAIN X
TRMB TERM FEATURES=(U40,1920),ADDR=(31,52),
      AUX1=(TP,73),LOW=MAIN,MEDIUM=MAIN,HIGH=MAIN X
```

- The following example shows two UTS 40W workstations and an 8406 diskette subsystem attached to a cluster controller. Each UTS 40W has a dual screen capability, and each display screen is defined as a separate terminal. This arrangement lets your program communicate with each screen and to any auxiliary devices related to them. The COP printer and the TP printer are physically connected to the terminals, while the diskette is physically connected to the cluster controller. Notice that the TRM5 and TRM6 definitions allow your program to communicate with the same 8406 diskette subsystem (one for each of the cassettes in the dual cassette subsystem), as well as the terminal printer.

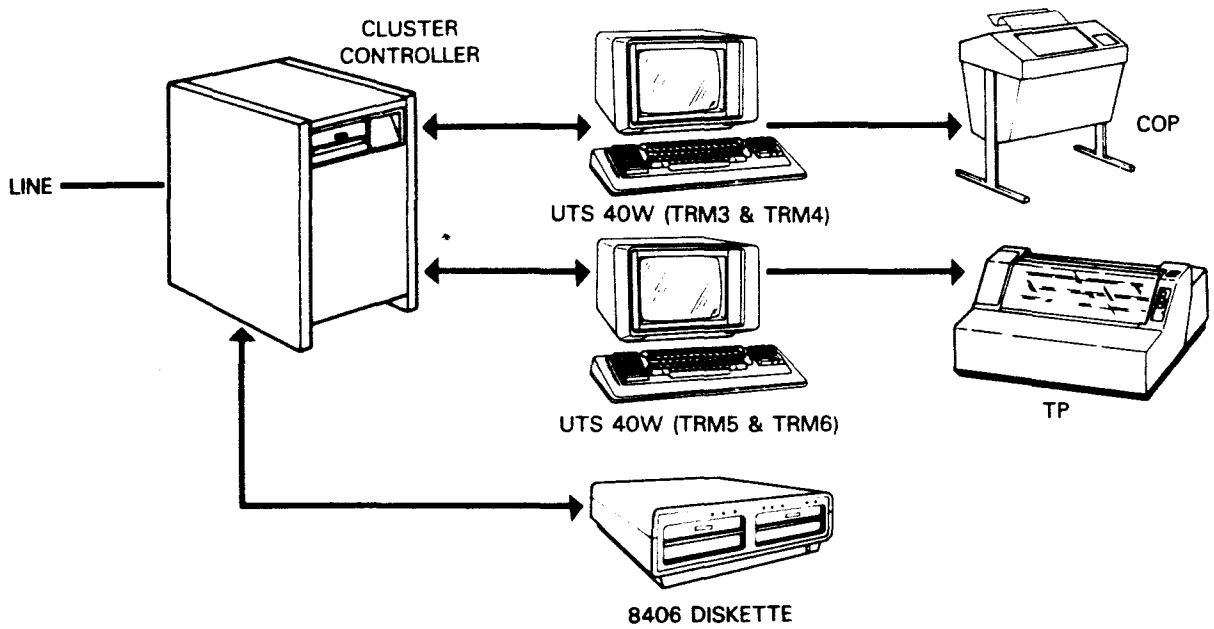

TRM3	TERM	FEATURES=(U40, 1920, CC), ADDR=(29, 51), AUX1=(COP, 73), LOW=MAIN	X
TRM4	TERM	FEATURES=(U40, 1920, CC), ADDR=(29, 52), AUX1=(COP, 73), LOW=MAIN	X
TRM5	TERM	FEATURES=(U40, 1920, CC), ADDR=(29, 53), AUX1=(TP, 73), AUX2=(TCS, 75, 76), AUX4=(TCS, 77, 78), LOW=MAIN	X
TRM6	TERM	FEATURES=(U40, 1920, CC), ADDR=(29, 54), AUX1=(TP, 73), AUX2=(TCS, 75, 76), AUX4=(TCS, 77, 78), LOW=MAIN	X

Configuring UTS 20/40/400 Terminals

- The following example illustrates how to attach remote printers to a cluster controller without dedicating a workstation to the print operation. In order to do this, the UTS 4000 remote print utility is required. The utility is described in the *UTS 4020/4040 System Utilities User Guide (UP-8218)*.

The equipment shown consists of one UTS 20W workstation, one UTS 40W workstation, one 8406 diskette subsystem, and a remote printer attached to a cluster controller.

The remote printer utility can create up to nine remote printer interfaces in a cluster controller, and each one you create must be identified by the host with a station identifier (sid). (In our example, we defined only one remote printer interface.) Data is routed through a remote printer interface to a printer as though it were a screen bypass feature.

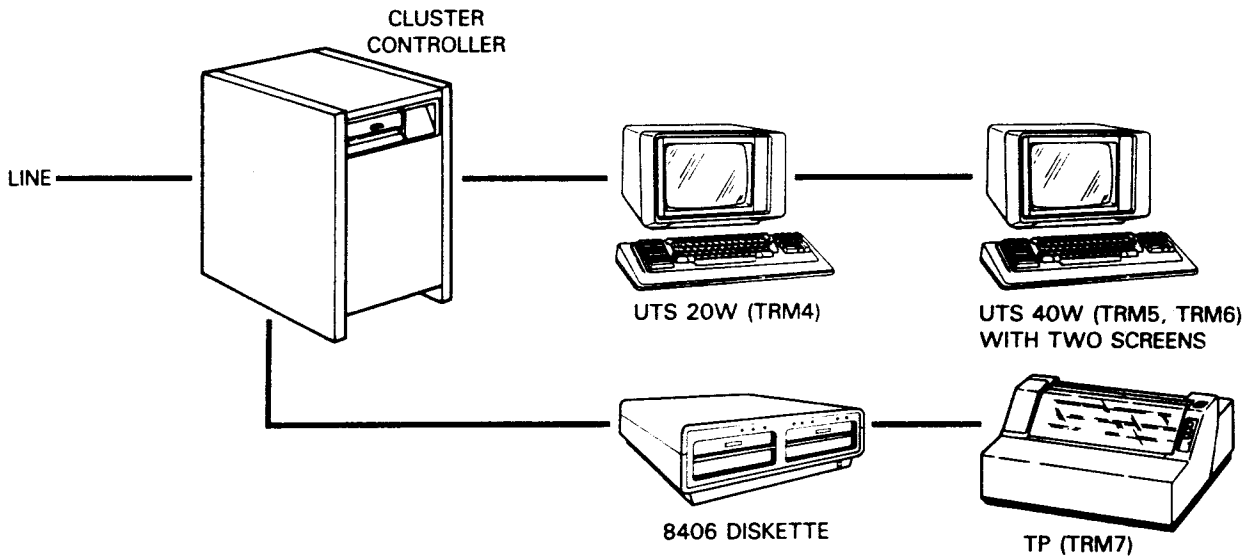

TRM4	TERM	FEATURES=(U20,1920,CC),ADDR=(29,51),AUX1=(TP,73),	X
		LOW=MAIN	
TRM5	TERM	FEATURES=(U40,1920,CC),ADDR=(29,52),LOW=MAIN	
TRM6	TERM	FEATURES=(U40,1920,CC),ADDR=(29,53),AUX1=(TP,73)	X
		AUX2=(TCS,75,76),AUX4=(77,78),LOW=MAIN	
TRM7	TERM	FEATURES=(U20,1920,SBT,CC),ADDR=(29,54),AUX1=(TP,73),	X
		LOW=MAIN	

The definition makes it possible to:

- Communicate (send/receive) with the screen of TRM4, or send a message to the terminal printer attached to TRM4 by specifying the auxiliary device (AUX1) in your program
- Communicate with the screen of the UTS 40W defined as TRM5. TRM5 and TRM6 define different screens on the same terminal. Note that TRM5 has no AUX parameter specified.
- Communicate with the alternate screen of the UTS 40W defined as TRM6, write to the terminal printer defined as AUX1, or access a disk drive function (read or write function) by specifying AUX2, AUX3, AUX4, or AUX5
- Print a message on the terminal printer by sending it to TRM7, AUX1. ICAM treats the remote printer interface as a screen bypass feature with a station identifier of 54.

B.2. Local Workstation Configurations

Specify `DEVICE=(LWS)` in the `LINE` macro for the workstation address.

- UTS 20D local workstation (Model I):

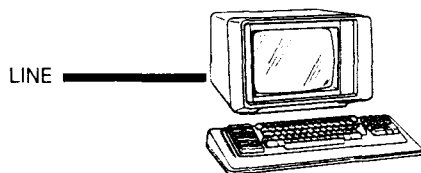

```
TRM1 TERM FEATURES=(U20),ADDR=(312),INPUT=YES,HIGH=MAIN
```

- UTS 40D local workstation (Model II) with auxiliary printer:

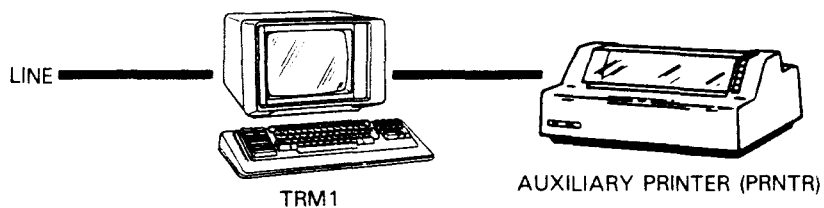

```
TRM2 TERM FEATURES=(U40),ADDR=(312),AUX1=(PRNTR),INPUT=YES,HIGH=MAIN
```

- SVT 1122 local workstation with auxiliary printer:

```
TRM3 TERM FEATURES=(1122),ADDR=(C13),AUX1=(PRNTR),INPUT=YES,LOW=MAIN
```

B.3. Remote Workstation Configurations

For all remote workstation configurations, you must specify the following:

- DCA=YES in the CCA macro
- UDUCT and LINKPAK parameters on the BUFFERS macro
- DEVICE=(RWS) in the LINE macro for the communication line that supports the terminal
- MODE=SYSTEM on the LOCAP specified as TYPE=DMI
- A PGROUP macro for each RWS polling group
- UTS 20 remote workstation with single screen storage:

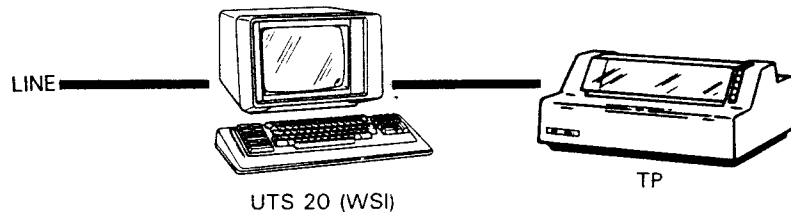

```

PGROUP PGID=32
WS1 TERM FEATURES=(U20,1920),ADDR=(32,51),
AUX1=(TP,73),LOW=MAIN
    
```

- UTS 20 remote workstation with dual screen storage:

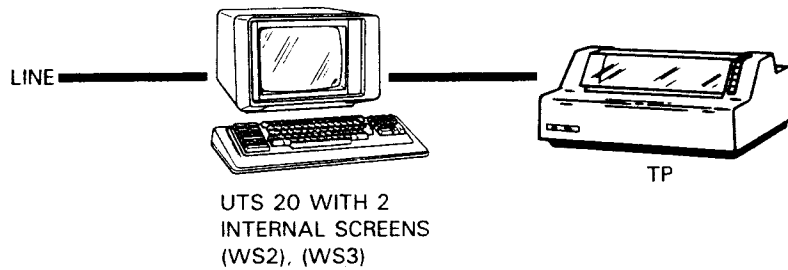

```

PGROUP PGID=33
WS2 TERM FEATURES=(U20,1920,,,PRIMARY),ADDR=(33,51),
AUX1=(TP,73),LOW=MAIN,MEDIUM=MAIN,HIGH=MAIN
WS3 TERM FEATURES=(U20,1920,,,SECONDARY),ADDR=(33,52),
AUX1=(TP,73),LOW=MAIN,MEDIUM=MAIN,HIGH=MAIN
    
```

Configuring UTS 20/40/400 Terminals

- UTS 40 remote workstation with dual screen storage:

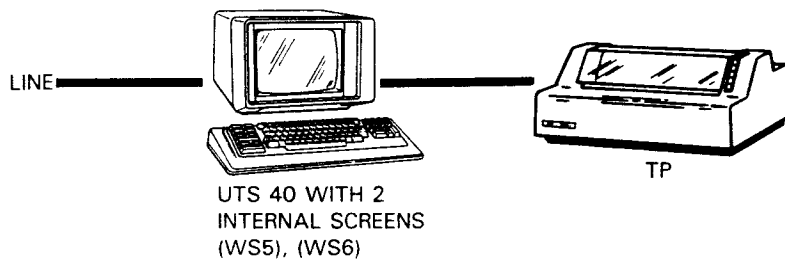

```
PGROUP PGID=35
WS5 TERM FEATURES=(U40,1920,,PRIMARY),ADDR=(35,51), X
      AUX1=(TP,73),LOW=MAIN,MEDIUM=MAIN,HIGH=MAIN
WS6 TERM FEATURES=(U40,1920,,SECONDARY),ADDR=(35,52), X
      AUX1=(TP,73),LOW=MAIN,MEDIUM=MAIN,HIGH=MAIN
```

Index

A

ABBADDR operand, RDTE macro, 2-96
Activity request packet pools
 maintaining statistics, 2-20
 specifying, 2-3, 2-7
 statistics area format, (figure) 4-18
 statistics area sample, (figure) 4-19
 statistics areas, 2-8, 4-17
 Telcon network, A-8
ADDR operand, TERM macro, 2-126
ADDRESS operand
 LDTE macro, 2-47
 RDTE macro, 2-96
 STATION macro, 2-104
ALTD operand, TERM macro, 2-136
Alternate process file, defining label, 2-136
ANSWER operand, TERM macro, 2-141
ARP operand, BUFFERS macro, 2-7
ASCII code, LINE macro, 2-56
Automatic dialing, lines, 2-63, 2-64
Automatic line buffering routines, CCA
 macro, 2-19
Automatic line turnaround, 2-62
Auxiliary devices
 addresses, 2-130
 defining, Telcon network definition, A-3
 disk-queued TCI network, (figure) 3-19
 standard interface dedicated network,
 3-16
 standard interface dedicated network
 with none, (figure) 3-12
AUX1 operand, TERM macro, 2-130

B

Batch terminals, input record size, 2-142
Binary synchronous communications
 LINE macro, 2-55
 TERM macro, 2-121
BSC operand
 LINE macro, 2-55
 TERM macro, 2-121
BUFF operand, JRNFILE macro, 2-45
Buffer pools
 expansion factor, 2-7
 length, 2-5
 maintaining statistics, 2-20
 number, 2-5
 physical link, 2-155
 specifying, 2-3
 statistics areas, 2-8, 4-17
 Telcon network, A-8
Buffer statistic records, 4-8
Buffers
 link, 2-9
 network, specifying, 2-3
 pools (See Buffer pools)
 (See also Network buffers)
BUFFERS macro
 applicability, (table) 2-4
 DISCFILE macro, 2-34
 examples, 2-13
 format, 2-3
 global networks, 3-42
 journal file, 4-9
 operands, 2-5
 statistics areas, 4-17
 Telcon network, A-8
 use, 2-3

C

- CACH statement, 5-4
- CALL operand
 - LINE macro, 2-63
 - STATION macro, 2-104
 - TERM macro, 2-126
- Call progress signal
 - action default values, (table) 2-26
 - creating, (table) 2-25
 - LDTE macro, 2-49
- Calling line, identification, 2-47
- Calling number, local DTE, 2-47
- CALLING operand, SUB macro, 2-108
- CALL NO operand
 - SUB macro, 2-106
 - TRUNK macro, 2-146
- Calls, TRUNK macro, 2-148
- Card processors
 - LINE macro, 2-55
 - standard interface network definition, 3-14
 - TERM macro, 2-120, 2-133
- CARRIER operand, PDN macro, 2-84
- CAT operand, CONGRP macro, 2-23
- CATP operand
 - LPORT macro, 2-83
 - SUB macro, 2-107
- CC statement, 5-5
- CCA macro
 - applicability, (table) 2-15
 - DCA global networks, 3-46
 - examples, 2-21
 - format, 2-14
 - journaling, 4-8
 - operands, 2-17
 - single-node global networks with remote workstations, 3-42
 - Telcon network, A-11
 - use, 2-14
- CCAID operand, CCA macro, 2-18
- CCAMOD parameter, ICAM generator, 5-1
- CGRPEND macro, 2-22
- CHAN operand
 - LINE macro, 2-63
 - VLINE macro, 2-153
- Channel characteristics, DCP, 2-29
- Channel number, 2-29
- CHANNEL statement, A-2
- Channels, virtual, VLINE macro, 2-151
- Character detect table, LINE macro, 2-73
- Character interpret table, LINE macro, 2-73
- CIRCSW operand, LINE macro, 2-72
- Circuit-switched public data network
 - call progress signal, (table) 2-25
 - DATEX-L (*See* DATEX-L PDN)
 - defining local data terminal equipment, 2-47
 - network definition, 3-58
 - NORDIC (*See* NORDIC PDN)
 - PDN macro, 2-86
 - remote data terminal equipment, RDTE macro, 2-96
- Circuits
 - permanent virtual (*See* Permanent virtual circuit)
 - switched virtual (*See* Switched virtual circuits)
- Closed user group
 - code, 2-107
 - number (RDTE), 2-97
- CMDADDR operand, VLINE macro, 2-156
- CMWO operand, EUP macro, 2-41
- Cn/Mn operator command, 5-5
- CNID operand, DCPCHNL macro, 2-29
- COBOL programs, LOCAP macro, 2-79
- Collect calls, SUB macro, 2-107
- COMMCT phase
 - ICAM generation, 5-1
 - sample, 5-2
- Communications, system console, 5-13
- Communications output printer (COP), 3-16
- Communications physical interface (CPI)
 - CCA macro, 2-20
 - definition, 1-3
- Communications user program, 5-6
- Computer message waiting
 - message, 2-141
 - sentinel, 2-41
- Computer nodes, VLINE macro, 2-151
- Configuration group
 - indicating end, 2-22
 - UDLC/NRM line, 2-23
- CONGRP macro, 2-23

- Connection processing, line initialization, 2-23
- CONTYP operand, CONGRP macro, 2-23
- Console type-ins, 5-13
- Control areas, disk queuing file, 2-32
- Control page, destructive space, 2-20, 2-73
- Control unit address, DCPCHNL macro, 2-29
- CPI (See Communications physical interface)
- CPS operand, CPSTB macro, 2-28
- CPSTB macro
- applicability, (table) 2-27
 - call progress signal action default values, (table) 2-26
 - examples, 2-28
 - format, 2-25
 - LDTE macro, 2-49
 - NORDIC PDN, 3-59, 3-62, 3-68
 - operands, 2-27
 - use, 2-25
- CPSTBL operand, LDTE macro, 2-49
- CPU-CPU BSC connection, 2-56
- CSU, A-5
- CTABLE operand, LINE macro, 2-73
- CUG operand, SUB macro, 2-107
- CUGADDR operand, RDTE macro, 2-97
- D**
- Data communications terminals (DCT)
- LINE macro, 2-53
 - TERM macro, 2-114, 2-126, 2-130, 2-133 (See also Terminals)
- Data circuit-terminating equipment (DCE)
- packet-switched PDNs, 3-70
 - TRUNK macro, 2-146
 - VLINE macro, 2-156
- Data packets, TRUNK macro, 2-148
- Data terminal communications equipment (DCE)
- circuit-switched PDNs, 3-58
 - VLINE macro, 2-151
- Data terminal equipment (DTE)
- address, local subscriber, 2-146
 - circuit-switched PDN, 3-58
 - local, defining, 2-47
 - packet-switched PDN, 3-70
 - remote (See Remote data terminal equipment)
 - remote subscriber, 2-105
 - TRUNK macro, 2-146
 - VLINE macro, 2-151
- DATAPAC public data network
- network definition, 3-58, 3-83
 - three-node coding, network definition, (figure) 3-89
 - two-node coding, network definition, (figure) 3-85
 - two-node environment, (figure) 3-84
 - VLINE macro, 2-153
- DATATIM operand, TRUNK macro, 2-148
- Date stamp, queued messages, 2-19
- DATEX public data network
- network definition, 3-58, 3-83
 - two-node environment, (figure) 3-84
- DATEX-L public data network
- dedicated network definition, (figure) 3-92
 - description, 3-91
 - environment, typical, (figure) 3-61
 - global network definition, (figure) 3-92
 - LINE macro, 2-72
 - network definition, 3-58
 - TERM macro, 2-142
- DCA (See Distributed communications architecture)
- DCA operand, CCA macro, 2-18
- DCATS statement, A-2
- DCP
- channel characteristics, 2-29
 - downline or cross-channel loading, 2-20
- DCPCHNL macro, 2-29, A-13
- DCPLOAD operand, CCA macro, 2-21
- DCPTS statement, A-3
- DDI (See Direct data interface)

Index

- DDX public data networks
 - coding, three nodes, (figure) 3-79
 - network definition, 3-58, 3-75
 - SUB macro, 2-108
 - three-node, 3-75
 - three-node environment, (figure) 3-76
 - virtual circuit group, 2-149
- Dedicated networks
 - CCA macro, 2-17
 - defining, 3-6
 - direct data interface definition, 3-6
 - interfaces, 1-2
 - line characteristics, 2-50
 - macroinstruction usage by network
 - definition type, (table) 3-2
 - standard interface definition, 3-9
 - transaction control interface definition, 3-18
- Demand mode interface (DMI), 1-2
- DESPACE operand
 - CCA macro, 2-21
 - LINE macro, 2-73
 - TERM macro, 2-145
- Destination node
 - LOCAP macro, 2-79
 - LPORT macro, 2-81
- Destruction space specification
 - CCA macro, 2-20
 - LINE macro, 2-73
 - TERM macro, 2-145
- Device addresses, TERM macro, 2-126
- Device independent control expression (DICE)
 - sequence, line length, 2-41
 - TERM macro, 2-138
- DEVICE operand
 - LINE macro, 2-53
 - VLINE macro, 2-153
- DEVICE statement, A-3
- Devices, auxiliary (See Auxiliary devices)
- DIALER operand, LINE macro, 2-64
- Dialog, defining network, 1-4
- DICE operand, TERM macro, 2-138
- Direct-call facility, remote data terminal equipment, 2-97
- Direct data interface (DDI)
 - activity request packets, 2-9
 - CCA macro, 2-17
 - coding for network definition, (figure) 3-9
 - description, 1-2
 - macroinstructions, (table) 3-7
 - network, (figure) 3-8
 - network definition, 3-6
- DIRECT operand, RDTE macro, 2-97
- DISCFILE macro
 - applicability, (table) 2-32
 - examples, 2-34
 - format, 2-31
 - operands, 2-31
 - use, 2-31, 4-1
- DISIN operand, TERM macro, 2-142
- Disk buffering file
 - allocating space, 4-4
 - creating, 2-31
- Disk files
 - buffering, 2-31, 4-4
 - creating, 4-1
 - queuing, 4-3, 4-5
 - sample job control stream, allocating files, (figure) 4-5
 - space allocation, 4-3
 - TCI network definition, (figure) 4-5
- Disk-queued TCI network with auxiliary devices, (figure) 3-19
- Disk-queuing file
 - allocating space, 4-3, 4-5
 - creating, 2-31
- DISOUT operand, TERM macro, 2-142
- Distributed communications architecture (DCA)
 - CCA macro, 3-91
 - DATEX-L PDNs, 3-91
 - global networks, 3-46
 - ICAM non-DCA and DCA global networks, (figure) 3-24

- interactive terminal with DCP, (figure)
3-51
 - logical port, 2-81
 - multinode, TERM macro, 2-143
 - multinode, VLINE macro, 2-151
 - multinode DDP with interactive terminal,
(figure) 3-50
 - multinode network definition for DDP,
(figure) 3-48
 - NRM, using, 3-53
 - OS/3 to UNIX O/S connectivity, (figure)
3-56
 - Distributed communications processor (DCP)
 - DCA global networks, 3-46, (figure)
3-51, 3-52
 - multiple paths, System 80, A-63
 - termination systems, A-3
 - Distributed data processing (DDP)
 - DCA global networks, 3-46, (figure) 3-48
 - DCP as intermediate node, (figure) 3-52
 - multinode with interactive terminal,
(figure) 3-50
 - Distribution lists
 - creating, 2-35
 - global networks, 3-25
 - DLIST macro, 2-35
 - DMI (*See* Demand mode interface)
 - DSCI operand, RDTE macro, 2-98
 - DSCO operand, RDTE macro, 2-98
 - Dual-screen devices, TERM macro, 2-117,
2-119
 - DUST macro, errors, 2-18
 - DUSTERR operand
 - CCA macro, 2-18
 - LOCAP macro, 2-78
 - DVCGID operand, TERM macro, 2-143
 - Dynamic sessions
 - DCA global networks, 3-46
 - establishing, 6-6
 - global networks, 3-37
- ## E
- EBCDIC code, LINE macro, 2-56
 - EDT operand, EUF macro, 2-41
 - END operand, CPSTB macro, 2-28
 - End users
 - how they communicate, 3-38
 - local, 2-82
 - profile, 2-38
 - remote, 2-83
 - static sessions, 2-100
 - ENDCCA macro, 2-37, A-14
 - Error recovery, LPORT macro, 2-83
 - ETB operand, EUP macro, 2-41
 - EUF operand, EUP macro, 2-38
 - EUP macro
 - applicability, (table) 2-39
 - controlling message format, 4-6
 - examples, 2-42
 - format, 2-38
 - operands, 2-38
 - programming notes, 2-41
 - use, 2-38
 - EU1 operand
 - LPORT macro, 2-82
 - SESSION macro, 2-100
 - EU2 operand
 - LPORT macro, 2-83
 - SESSION macro, 2-100
 - Expansion factor, buffer pool, 2-7
 - EXPFACT operand, BUFFER macro, 2-7
 - External termination system, A-2
- ## F
- FEATURES operand
 - CCA macro, 2-19
 - TERM macro, 2-114
 - FILE DIV operand, DISCFILE macro, 2-32

Index

Files

- disk, creating, 2-31, 4-1
- journal, creating, 2-44
- process, creating, 2-89

Format edit (*See* Message format editing feature)

Format editing facility, EUP macro, 2-38

Frames

- level address, VLINE macro, 2-156
- STATION macro, 2-104

G

GAWAKE operand, CCA macro, 2-20

Global networks

- CCA macro, 2-17
 - configurations, 3-21
 - creating LOCAP value, 2-76
 - DCA, 3-46
 - definitions, 1-2, 3-25,
 - establishing static sessions, 2-99
 - ICAM non-DCA and DCA, (figure) 3-24
 - line characteristics, 2-50
 - macroinstruction usage by network
 - definition type, (table) 3-2
 - macroinstructions, order of presentation, 3-25
 - multinode, (figure) 3-23
 - single-node
 - standard interface, (figure) 3-22, 3-30
 - with IMS and local workstations, 3-32
 - with IMS and terminals using interactive services, 3-35
 - with remote workstations, 3-42
 - using queues, 3-28
 - VLINE macro, 2-151
- Global user service task (GUST)
- executing, (figure) 5-8
 - global network configurations, 3-21
 - ICAM initialization and shutdown, 5-5
 - initialization and shutdown, 5-7
 - initializing, 5-8
 - loading a communications user program, 5-6
 - remote workstation startup, 6-9

H

HIGH operand

- LINE macro, 2-68
- LOCAP macro, 2-78, 3-28
- PRCS macro, 2-91
- TERM macro, 2-135, 3-29

I

I field size, 2-104

IAS operand, LOCAP macro, 2-80

IBERPAC public data network

- network definition, 3-58, 3-83
- SUB macro, 2-108
- typical 2-node environment, (figure) 2-84
- VLINE macro, 2-153

IBM 3270 terminal system

- LINE macro, 2-57
- TERM macro, 2-126

IBM 3277 display station, 2-124, 2-125

IBM 3284/3286 printer, 2-124

ICAM (*See* Integrated communications access method)

ID operand

- DCPCHNL macro, 2-29
- LINE macro, 2-64
- VLINE macro, 2-153

IMS/TIP30 LOCAP, 2-123

Incoming calls, LDTE macro, 2-47

Information management system (IMS)

- DCA global networks, 3-46
- LINE macro, 2-56
- single-node global networks, 3-32
- TCI network definition, 3-18

INHIBIT operand, TERM macro, 2-140

INID operand, LDTE macro, 2-47

INPUT operand

- LINE macro, 2-66
- TERM macro, 2-134

Input/output microprocessor

- LINE macro, 2-63, 2-64
- VLINE macro, 2-153

- Input queues, priority, 2-68
 - Input record size, batch terminals, 2-142
 - Input translation, TERM macro, 2-139
 - Input window size
 - permanent virtual circuit, 2-94
 - switch virtual circuit, 2-108
 - INONLY operand, TERM macro, 2-141
 - INRECSZ operand, TERM macro, 2-142
 - Integrated communications access method (ICAM)
 - general comments, A-63
 - generating, 5-1
 - GUST, 5-7
 - incorporating features, 4-1
 - initialization and shutdown, 5-5
 - interfaces (See Interfaces)
 - loading an ICAM symbiont, 5-5
 - macroinstructions (See Macroinstructions)
 - network definition (See Network definition)
 - networks (See Networks)
 - supported terminals, maximum line speed, (table) 2-60
 - system console communications, 5-13
 - Telcon (See Telcon)
 - terminal operations (See Terminals)
 - Interactive services
 - DCA global networks, 3-46
 - LOCAP macro, 2-80
 - single-node global networks with IMS, 3-35
 - Interactive terminal
 - DCP, global network, (figure) 3-51
 - multinode DDP, DCA global networks, (figure) 3-50
 - INTERCEPT operand, TERM macro, 2-137
 - Interfaces
 - activity request packets, 2-7
 - dedicated networks (See Dedicated networks)
 - global networks (See Global networks)
 - special, 1-3
 - IOSVC operand, TRUNK macro, 2-148
 - ISVC operand, TRUNK macro, 2-148
 - IWS operand
 - PVC macro, 2-94
 - SUB macro, 2-108
- ## J
- Job control streams
 - sample, allocating disk queuing and buffering files, (figure) 4-5
 - sample, executing a user program, (figure) 5-7
 - sample, executing GUST, (figure) 5-8
 - JOBINIT operand, LOCAP macro, 2-79
 - JOBNAME operand, LOCAP macro, 2-79
 - JOURN macro, 4-10
 - Journal file
 - allocating, 4-13
 - buffer and terminal statistics, 4-9, (figure) 4-11
 - creating, 2-44, 4-8
 - global networks, 3-25
 - Journal records, 4-8
 - Journal utility, 2-44, 4-7
 - Journaling
 - allocating journal file, 4-13
 - building journal file, 4-8
 - description, 4-7
 - routines, CCA macro, 2-20
 - sample network definitions, 4-10
 - types of records, 4-8
 - JRNFILE macro
 - description, 2-44
 - journal file, 4-9, 4-13
 - JRNINIT operand, CCA macro, 2-20
- ## K
- K operand, VLINE macro, 2-154

Index

L

- LBL operand, LINE macro, 2-67
- LBUF operand, VLINE macro, 2-155
- LCGN operand
 - PVC macro, 2-94
 - VCGROUP macro, 2-149
- LCN operand, PVC macro, 2-93
- LDTE macro
 - circuit-switched PDN, 3-59
 - description, 2-47
 - NORDIC PDN, 3-62, 3-68
- Leased lines, SLCA ports, (figure) 2-65
- LGROUP operand, LDTE macro, 2-49
- Line editing argument, 2-41
- Line length, 2-41
- LINE macro
 - applicability, (table) 2-52
 - CALL operand, 2-63
 - CHAN operand, 2-63
 - CIRCSW operand, 2-72
 - CTABLE operand, 2-73
 - DATEX-L PDN, 3-91
 - DESPACE operand, 2-73
 - DEVICE operand, 2-53
 - DIALER operand, 2-64
 - example, 2-75
 - format, 2-50
 - global networks, 3-42
 - HIGH operand, 2-68
 - ID operand, 2-64
 - INPUT operand, 2-66
 - journal file, 4-9
 - LBL operand, 2-67
 - line characteristics and TYPE specifications, (table) 2-59
 - line-speed value, (table) 2-60
 - local workstation configuration, B-8
 - LOW operand, 2-68
 - maximum line speed of ICAM-supported terminals, (table) 2-60
 - MEDIUM operand, 2-68
 - NORDIC PDN, 3-68
 - PDN network definition, 3-58
 - RDHLQ operand, 2-68
 - RECONNECT operand, 2-68
 - RETRY operand, 2-69
 - STATS operand, 2-70
 - TIMEOUT operand, 2-70
 - translation tables, 4-14
 - TYPE operand, 2-58
 - use, 2-50
 - XLATE operand, 2-71
- LINE operand
 - LPORT macro, 2-81
 - STATION macro, 2-104
- Lines
 - automatic dialing, 2-62
 - automatic turnaround, 2-62
 - buffer length, 2-56, 2-67
 - devices connected, 2-53
 - leased, specifying SLCA ports, (figure) 2-65
 - local DTE, 2-49
 - maximum speed of ICAM-supported terminals, (table) 2-60
 - performance records, 4-8
 - profile, 2-38
 - queuing, 2-50, 2-137
 - reconnection, 2-68
 - specifying characteristics, 2-50, 2-58, (table) 2-59
 - speed, 2-58, 2-67, 2-155
 - speed values, (table) 2-60
 - switched, 2-62, 3-55
 - synchronous transmission, 2-62
 - TYPE specifications, (table) 2-59
 - unattended answering, 2-63
- Link buffer pool, Telcon, A-8
- Link buffers
 - length, 2-11
 - number, 2-10
 - specifying, 2-9
 - statistics areas, 2-8
- Link control, station, 2-103
- Link level protocol, CONGRP macro, 2-23
- LINKPAK operand, BUFFERS macro, 2-9
- Links, physical, VLINE macro, 2-151, 2-153
- Loading an ICAM symbiont, 5-5

- Local data terminals, defining equipment, 2-47
 - Local data terminating equipment (LDTE), 3-68
 - Local end user
 - defining, 2-82
 - static sessions, 2-100
 - Local workstation
 - generation and logon/sign-on procedures, (table) 6-2
 - LINE macro, 2-57
 - log on, 6-8
 - releasing from ICAM, 6-11
 - single-node global network, 3-32
 - specifying, 6-3
 - startup procedures, 6-8
 - TERM macro, 2-120, 2-128
 - UTS 20/40/400 terminals, B-8
 - LOCAP files
 - DCA global networks, 3-46
 - defining (See LOCAP macro)
 - global networks, 3-21, 3-25, 3-32, 3-42
 - Telcon networks, A-15
 - LOCAP macro
 - applicability, (table) 2-77
 - DDX pdn, 3-77
 - FORMAT, 2-76
 - NORDIC PDN, 3-62
 - operands, 2-78
 - PDN network definition, 3-58
 - queues in global networks, using, 3-28
 - Telcon network, A-15
 - use, 2-76
 - Logical channel group number
 - permanent virtual circuit, 2-94
 - VCGROUP macro, 2-149
 - Logical channel number, 2-93
 - Logon procedures, terminals and workstations, (table) 6-2
 - LOW operand
 - LINE macro, 2-68
 - LOCAP macro, 2-78, 3-28
 - PRCS macro, 2-90
 - TERM macro, 2-135, 3-29
 - LPOR macro
 - circuit-switched PDN, 3-59, 3-62
 - description, 2-81
 - Telcon network, A-17
 - L3MOD operand, PDN macro, 2-86
- ## M
- Macroinstructions
 - BUFFERS, 2-3, A-8
 - CCA, 2-14, A-11
 - CGRPEND, 2-22
 - circuit-switched PDN network definition, (table) 3-58, (table) 3-60
 - CONGRP, 2-23
 - CPSTB, 2-25
 - DCPCHNL, 2-29, A-13
 - DDI network definition, (table) 3-7
 - DISCFIL, 2-31
 - DLIST, 2-35
 - ENDCCA, 2-37, A-14
 - EUP, 2-38
 - global network definition, 3-25, (table) 3-26
 - JRNFILE, 2-44
 - LDTE, 2-47
 - LINE, 2-50
 - listing, 2-1
 - LOCAP, 2-76, A-15
 - LPOR, 2-81, A-17
 - packet-switched PDN network definition, (table) 3-72
 - PDN, 2-84
 - PGROUP, 2-87
 - PRCS, 2-89
 - PVC, 2-93
 - RDTE, 2-96
 - SESSION, 2-99
 - standard interface network definition, (table) 3-10
 - STATION, 2-102
 - SUB, 2-105
 - TCI network definition, (table) 3-10

Index

- Telcon, A-6
 - Telcon/ICAM macroinstruction
 - relationships, (table) A-24
 - TERM, 2-109, A-19
 - TRUNK, 2-146
 - usage by network definition type, (table)
 - 3-2
 - VCGROUP, 2-149
 - VLINE, 2-151
 - Main memory queuing, 2-32
 - MAPPER 5 system, LINE macro, 2-58, 2-67
 - MAXIFLD operand, STATION macro, 2-104
 - MCP parameters
 - description, 5-1
 - format, 5-4
 - MEDIUM operand
 - LINE macro, 2-68
 - LOCAP macro, 2-78, 3-28
 - PRCS macro, 2-91
 - TERM macro, 2-135, 3-29
 - Message control program (MCP), 5-1, 5-4
 - Message dequeuing notices, 4-8
 - Message format editing feature
 - description, 4-6
 - TERM macro, 2-140
 - Message header, 2-5
 - Message processing routine
 - journaling, (figure) 4-12
 - standard interface dedicated network
 - definition, 3-14
 - Messages
 - controlling format, 4-6
 - date and time stamp, 2-19
 - GUST, 5-8
 - input, destination, 2-66, 2-134
 - list of destination, 2-35
 - output, editing, 2-38
 - output, queuing, 2-137
 - priority, 2-89
 - process files, 2-89
 - segmented, 2-19
 - terminal, (See TERM macro)
 - time-out values, 2-70
 - Mode of operation, 2-34
 - MODE operand, LOCAP macro, 2-80
 - MSGWAIT operand, TERM macro, 2-141
 - MSGSIZE operand, DISCFILE macro, 2-31
 - Multinode networks
 - DCA global networks, 3-46
 - DDP with interactive terminal, (figure)
 - 3-50
 - global network configurations, 3-19,
 - (figure) 3-23
 - LOCAP macro, 2-79
 - PRCS macro, 2-91
 - Multiple paths, System 80 and DCP, A-63
 - MUX operand, SUB macro, 2-107
 - MXCALL operand, RDN macro, 2-86
- ## N
- NEGO operand, SUB macro, 2-108
 - Negotiator option, SUB macro, 2-108
 - Networks
 - buffer pools, specifying, 2-3
 - CCA macro, 2-14, A-11
 - dedicated (See Dedicated networks)
 - definition (See Network definitions)
 - general characteristics, specifying, 2-14
 - global (See Global networks)
 - interfaces, 1-2
 - line characteristics, 2-50
 - multinode, 2-79
 - OS/3 configurations, (table) 3-4
 - relating Telcon and ICAM networks, A-1
 - Telcon (See Telcon)
 - (See also Public data networks)
 - Network buffers
 - pool usage, 4-17
 - specifying, 2-3
 - statistics, 2-8, 2-20
 - statistics area format, (figure) 4-18
 - statistics area sample, (figure) 4-19
 - Telcon network, A-8
 - (See also Buffer pools)
 - Network definitions
 - DCA global, 3-46
 - dedicated, 3-6
 - description, 1-1

- direct data interface, 3-6
 - ending, 2-37, A-14
 - global, 1-2, 3-21
 - indicating end, 2-37
 - journaling, 4-10
 - macroinstruction usage by network type, (table) 3-2
 - macroinstructions (*See* Macroinstructions)
 - preparing, 3-1
 - public data networks, 3-58
 - saving copy, 2-18
 - standard interface, 3-9
 - starting, 2-14
 - Telcon (*See* Telcon)
 - user-own-code translation table, 4-14
 - using the ICAM dialog, 1-4
 - Nine thousand remote (NTR), 1-3
 - Node identifier, CCA macro, 2-17
 - Nodes
 - intermediate, DCA global networks, (figure) 3-52
 - VLINE macro, 2-151
 - NOR operand, CPSTB macro, 2-28
 - NORDIC public data network
 - end-user sessions, (table) 3-66
 - environment
 - computer to computer, (figure) 3-61
 - computer to UTS 20X terminal, (figure) 3-67
 - network definitions, 3-58, (figure) 3-63, (figure) 3-69
 - NRM
 - configuration group, 2-22, 2-23
 - DCA network, 3-53
 - NTR (*See* Nine thousand remote)
 - NUMBER operand, VCGROUP macro, 2-150
- O**
- ODNR records, 4-8
 - OPCOM operand, BUFFERS macro, 2-9
 - Operating System/3 (OS/3), basic network configuration, (table) 3-4
 - DCA global networks, 3-53
 - sample Telcon network configurations, A-27
 - Operator communications packets, 2-9
 - OSVC operand, TRUNK macro, 2-148
 - OUTBARD operand, LDTE macro, 2-49
 - Outgoing calls, LDTE macro, 2-48
 - OUTID operand, LDTE macro, 2-48
 - OUTONLY operand, TERM macro, 2-142
 - Output delivery notice
 - CCA macro, 2-19
 - producing records, 2-20
 - Output line, length, 2-41
 - Output messages, editing, 2-38
 - Output queues, priority, 2-78
 - Output translation, TERM macro, 2-139
 - Output window size
 - permanent virtual circuit, 2-95
 - switched virtual circuit, 2-108
 - OVS operand
 - PVC macro, 2-95
 - SUB macro, 2-108
- P**
- Packet-switched public data networks
 - DATAPAC, TRANSPAC, DATEX, IBERPAC PDNs, 3-83
 - defining a permanent virtual circuit, PVC macro, 2-93
 - environment, (figure) 3-71
 - LOCAP file, 2-79
 - network definition, 3-70
 - PDN macro, 2-86
 - remote subscriber, 2-105
 - static sessions, 2-99
 - three-node DDX, 3-75
 - trunk definition, 2-146
 - Packets, data, TRUNK macro, 2-148
 - Page profile, 2-38
 - PASSWORD operand, CCA macro, 2-18

Index

- PDN macro
 - description, 2-84
 - packet-switched PDN, 3-72
 - PDN network definition, 3-58
 - NORDIC PDN, 3-59, 3-62, 3-68
- Performance records, line and terminal, 2-20
- Permanent virtual circuit (PVC)
 - DDX PDN, 2-149
 - defining, PVC macro, 2-93
 - number provided by PDN, TRUNK macro, 2-147
 - packet-switched PDNs, 3-70
 - PSS PDN, 2-149
 - static sessions, 2-99, 2-101
- PGID operand, PGROUP macro, 2-88
- PGROUP macro
 - description, 2-87
 - global networks, 3-42
 - NORDIC PDN, 3-68
- Physical links, VLINE macro, 2-151, 2-153
- PINTV operand, TERM macro, 2-129
- PKTSIZ operand, PDN macro, 2-86
- PLIMIT operand, TERM macro, 2-141
- Polling groups downed, slow polling interval, 2-143
 - PGROUP macro, 2-87
- Polling intervals, PGROUP macro, 2-87
- Polling pass, TERM macro, 2-141
- Polls, time between, 2-129
- Pools
 - ARP (*See* Activity request packet)
 - buffer (*See* Buffer pools)
 - specifying, 2-3
- Port control word, LINE macro, 2-73
- Port number, 2-82
- PORT operand, LPORT macro, 2-82
- Ports
 - DCA logical, 2-81
 - flow control, SUB macro, 2-107
 - SLCA, specifying, (figure) 2-65
- PRCS macro
 - applicability, (table) 2-90
 - circuit-switched PDN, 3-62
 - example, 2-92
 - format, 2-89
 - operands, 2-90
 - use, 2-89
- PRFN operand, EUP macro, 2-38
- Programs
 - communications, loading, 5-5
 - definition, 1-3
- PRI operand, LPORT macro, 2-83
- PRIMARY operand, SESSION macro, 2-99
- Primary session, specifying, (figure) 2-101
- Priority, remote device handler, 2-122
- Priority queues
 - global networks, 3-29
 - input LINE macro, 2-78, 3-28
 - LPORT macro, 2-83
 - messages, 2-89
 - output, LINE macro, 2-68
 - output, TERM macro, 2-135, 3-29
- Process files
 - creating, PRCS macro, 2-89
 - defining label of alternate, 2-136
 - establishing a session, 6-7
 - global networks, 3-21, 3-25
 - how queues are accessed, (table) 2-91
 - queues in global networks, 3-29
- PROFIL operand, TERM macro, 2-140
- Profile
 - end user, 2-38
 - number, 2-140
- Program queues, global networks, 3-28
- Programs, user-written, global networks, with IMS, 3-32
- PROTYP operand, TERM macro, 2-143
- PSEUDO operand, TERM macro, 2-145
- PSS public data network
 - defining virtual circuit group, 2-149
 - network definition, 3-58
 - SUB macro, 2-108
- PTIME operand, PGROUP macro, 2-88
- Public data networks
 - circuit-switched (*See* Circuit-switched public data networks)
 - DATAPAC (*See* DATAPAC PDN)
 - DATEX (*See* DATEX PDN)

- DATEX-L (*See* DATEX-L PDN)
- DCA global networks, 3-46
- DDX (*See* DDX PDN)
- defining, PDN macro, 2-84
- defining a trunk, 2-146
- defining virtual circuit group, 2-149
- IBERPAC (*See* IBERPAC PDN)
- NORDIC (*See* NORDIC PDN)
- packet-switched (*See* Packet-switched public data network)
- programming ICAM, 3-58
- PSS (*See* PSS PDN)
- remote subscribers, SUB macro, 2-108
- TRANSPAC (*See* TRANSPAC PDN)
- virtual channels, 2-151
- X-21, LINE macro, 2-57
(*See also* Networks)
- PVC macro
 - description, 2-93
 - packet-switched PDN, 3-72
- PVC operand
 - SESSION macro, 2-101
 - TRUNK macro, 2-147
- Q**
- Queuing
 - line, 2-50
 - two-way simultaneous, 2-58
- Queues
 - global networks, 3-28
 - priority (*See* Priority queues)
- R**
- RBATCH operand, TERM macro, 2-143
- RBP (*See* Remote batch processing)
- RDHLQ operand, LINE macro, 2-68
- RDTE macro
 - description, 2-96
 - NORDIC PDN, 3-59, 3-68
- Receive-only device, 2-142
- RECONNECT operand, LINE macro, 2-68
- Records, journaling, 4-8
- Remote batch jobs, TERM macro, 2-143
- Remote batch processing (RBP), 1-3
- Remote data terminal equipment (RDTE)
 - defining, RDTE macro, 2-96
 - NORDIC PDN, 3-59, 3-68
- Remote device handlers
 - automatic line buffering, 2-19
 - LINE macro, 2-57
 - priority, 2-122
 - VLINE macro, 2-154
- Remote end user
 - defining, 2-83
 - static sessions, 2-100
- Remote identifier, TERM macro, 2-126
- Remote node, TERM macro, 2-137
- REMOTE operand
 - DCPCHNL macro, 2-29
 - LOCAP macro, 2-79, 3-28
 - LPORT macro, 2-81
 - PRCS macro, 2-91
 - STATION macro, 2-104
 - TERM macro, 2-137
- Remote session entry table, LPORT macro, 2-81, A-17
- Remote subscriber, SUB macro, 2-105
- Remote terminal group, TERM macro, 2-143
- Remote workstations
 - generation and logon/sign-on procedures, (table) 6-2
 - LINE macro, 2-57
 - LOCAP macro, 2-80
 - log on, 6-8
 - polling groups, 2-87
 - single-node global networks, 3-42
 - specifying, 6-5
 - startup procedures, 6-8
 - UTS 20/40/400 terminals, B-9
(*See also* Workstations)
- Reports, journal utility, 4-7
- Request-to-send signal, 2-58
- Restart, warm, 2-19
- Restart records, 2-19, 4-8

Index

- RETRY operand
 - LINE macro, 2-69
 - VLINE macro, 2-154
- REVCHG operand, SUB macro, 2-107
- RSPADDR operand, VLINE macro, 2-156
- RTIMER operand, BUFFERS macro, 2-12

- S**

- SAVE operand, CCA macro, 2-18
- Screen number, TERM macro, 2-126
- SCREENS operand, TERM macro, 2-143
- Segmented message processing, CCA macro, 2-19
- Send-only device, 2-141
- Session control, SUB macro, 2-107
- Session entry table, remote, 2-81
- SESSION macro
 - DCA global networks, 3-46
 - DDX PDN, 3-77
 - description, 2-99
 - global networks, 3-37
 - packet-switched PDN, 3-72
- Sessions
 - defining, A-3
 - dynamic (*See* Dynamic sessions)
 - establishing, 6-6
 - global networks, 3-37
 - OS/3 ICAM static, A-63
 - SESSION macro, 2-99
 - static (*See* Static sessions)
- SESSN statement, A-3
- Sign-off command (\$\$SOFF), 6-8
- Sign-on command (\$\$SON), 6-7
- Sign-on procedures, summary, (table) 6-2
- Single-line communications adapter (SLCA)
 - CPSTB macro, 2-28
 - defining ports, 2-64, (figure) 2-65
 - LINE macro, 2-63, 2-64, 2-73
 - VLINE macro, 2-153
- Single-node global networks
 - definition, 3-4
 - global network configurations, 3-21
 - IMS and local workstations, 3-32
 - IMS and terminals using interactive services, 3-35
 - remote workstations, 3-42
 - standard interface, (figure) 3-22, 3-30, (figure) 3-31
- Site identifier codes, TERM macro, 2-141
- Slow polling interval, 2-143
- Spooling, OS/3 terminal, A-63
- SPR operand, TERM macro, 2-143
- Staging areas, journal files, 2-45
- Standard interface (STDMCP)
 - basic definition, 3-11
 - CCA macro, 2-17
 - creating disk files, 4-2
 - DCA global networks, 3-46
 - description, 1-2
 - macroinstructions, order of presentation for network definition, (table) 3-10
 - network definition, 3-9
 - network definition using a message processing routine, 3-14
 - network definition with auxiliary devices, 3-16
 - network with auxiliary devices, (figure) 3-17
 - network with no auxiliary devices, (figure) 3-12, (figure) 3-13
 - single-node global network, (figure) 3-22, 3-30, (figure) 3-31
- STAT operand, BUFFERS macro, 2-8
- Static sessions
 - global network definition, 3-25, 3-32, 3-37
 - global networks, 2-99
 - OS/3 ICAM, A-63
- Station identifier, TERM macro, 2-126
- STATION macro, 2-102
- Station profile table, 2-101
- STATION statement, A-4
- Statistics
 - maintaining, 2-20
 - terminals, 2-70
- Statistics areas
 - buffer pools, 2-8
 - format, (figure) 4-18

- sample dump, (figure) 4-19
 - tracking buffer pool usage, 4-17
 - STAS operand, LINE macro, 2-70
 - STDMCP (*See* Standard interface)
 - SUB macro
 - applicability, 2-106
 - DDX PDN, 3-77
 - format, 2-105
 - operands, 2-107
 - packet-switched RDN, 3-72
 - PVC macro, 2-93
 - use, 2-105
 - SVT emulation, OS/3 to UNIX O/S
 - connectivity, (figure) 3-56
 - SVT local workstations, TERM macro, 2-120, 2-131, 2-134
 - Switched lines
 - DCA global networks, 3-55
 - LINE macro, 2-62
 - Switched virtual circuits
 - packet-switched PDNs, 3-70
 - SUB macro, 2-107, 2-108
 - TRUNK macro, 2-148
 - VCGROUP macro, 2-149
 - Symbiont, ICAM
 - creating, 5-5
 - definition, 1-3
 - loading, 5-5
 - Synchronous transmission lines, 2-62
 - System activity monitor (SAM), CCA macro, 2-19
 - System console communications, 5-13
 - System 80
 - multiple paths, DCP, A-63
 - PDNs, 3-58
 - System generation, ICAM, 5-1
- T**
- Tape cassette system (TCS), standard interface network definition, 3-16
 - TBR operand, CPSTB macro, 2-28
 - TCI (*See* Transaction control interface)
 - TCTUPD operand, TERM macro, 2-142
 - Telcon
 - front-end processor addressing, 2-29
 - macroinstructions, A-6
 - network definition statements, A-2
 - relating Telcon and ICAM networks, A-1
 - sample network configurations, A-27
 - Telcon/ICAM macroinstruction relationships, (table) A-24
 - Telcon/ICAM terminal operation comparison, A-25
 - TERM macro, 2-143, 2-145
 - VLINE macro, 2-151
 - Teletypewriters
 - LINE macro, 2-54
 - standard interface network definition, 3-14
 - TERM macro, 2-114, 2-133
 - TERM macro
 - ADDR operand, 2-126
 - ALTD operand, 2-136
 - ANSWER operand, 2-141
 - applicability, (table) 2-112
 - AUX operand, 2-130
 - BSC, 2-121
 - CALL operand, 2-126
 - DATEX-L PDN, 3-91
 - DCA global networks, 3-46
 - DCT 475/500/524, 2-114
 - DCT 1000, 2-114
 - DCT 2000, 2-120
 - DESPACE operand, 2-145
 - DICE operand, 2-138
 - DISIN operand, 2-142
 - DISOUT operand, 2-142
 - DVCGID operand, 2-143
 - FEATURES operand, 2-114
 - format, 2-109
 - global networks, 3-29
 - HIGH operand, 2-135
 - IBM 2780/3780, 2-121
 - IBM 3271, 2-124
 - IBM 3277, 2-125
 - INHIBIT operand, 2-140
 - INONLY operand, 2-141
 - INPUT operand, 2-134

Index

- INRECSZ operand, 2-142
- INTERCPT operand, 2-137
- journal file, 4-9
- LOW operand, 2-135
- MEDIUM operand, 2-135
- MSGWAIT operand, 2-141
- NORDIC PDN, 3-62, 3-68
- OUTONLY operand, 2-142
- PDN network definition, 3-58
- PINTV operand, 2-129
- PLIMIT operand, 2-141
- PROFIL operand, 2-140
- PROTYP operand, 2-143
- PSEUDO operand, 2-145
- RBATCH operand, 2-143
- REMOTE operand, 2-137
- SCREENS operand, 2-143
- SPR operand, 2-143
- SVT 1122, 2-120
- Telcon network, A-19
- TIMEFILL operand, 2-145
- translation tables, 4-14
- TTY/UTS 10, 2-114
- TCTUPD operand, 2-142
- UDS 2000, 2-114
- UNISCOPE 100/200, 2-114
- use, 2-109
- UTS 10, 2-114
- UTS 20, 2-116, B-2
- UTS 40, 2-118, B-4
- UTS 400, 2-115, B-1
- UTS 400 TE, 2-120
- V77 system, 2-114
- XLATE operand, 2-138
- 1004 card processor, 2-120
- 9200 system, 2-120
- 9300 system, 2-120
- TERM statement, A-4
- Terminal performance records, 4-8
- Termination systems within DCP, A-3
- Terminals
 - configuring, 6-1
 - controlling message format, 4-6
 - DCA global networks, 3-50, 3-51
 - defining, Telcon network definition, A-4
 - dialing, 2-63
 - dynamic sessions, 6-6
 - end-user communications, 3-38
 - generation and logon/sign-on procedures, (table) 6-2
 - global network configurations, 3-21
 - line buffer length, 2-67
 - LINE macro, 2-53, 2-67
 - line speed, (table) 2-60
 - local data, defining equipment, 2-47
 - single-node global networks with IMS, 3-35
 - specifying, 6-1
 - specifying characteristics, TERM macro, 2-109, A-19
 - specifying ICAM terminals to emulate workstations, 6-4
 - specifying local workstation, 6-3
 - specifying remote workstation, 6-5
 - spooling, A-63
 - startup procedure, terminal used as a workstation, 6-10
 - statistics, 2-70
 - Telcon/ICAM comparison, A-25
 - UTS 20/40/400, configuring, B-1
- THRESH operand, DISCFILE macro, 2-32
- Threshold value
 - BUFFERS macro, 2-6, 2-9
 - DISCFILE macro, 2-34
 - VLINE macro, 2-155
- Time stamp, queued messages, 2-19
- TIMEFILL operand, TERM macro, 2-145
- TIMER operand, RDTE macro, 2-98
- Timer stack entries, 2-11
- TIMEOUT operand
 - LINE macro, 2-70
 - VLINE, macro, 2-154
- Timeout values
 - data packet, trunk macro, 2-148
 - LINE macro, 2-70
 - VLINE, macro, 2-154
- TIP30 users, 2-56
- Transaction control interface (TCI)
 - CCA macro, 2-18
 - creating disk files, 4-1

- definition, 1-2
 - disk-queued TCI network with auxiliary devices, (figure) 3-19, (figure) 3-20
 - macroinstructions used in network definition, (table) 3-10
 - network definition, 3-18
 - network definition using disk files, (figure) 4-5
- TRANSCODE code, LINE macro, 2-56
- Translation tables
- incorporating your own, 4-14
 - LINE macro, 2-71
 - TERM macro, 2-138
- TRANSPAC public data network
- network definition, 3-58, 3-83
 - two-node environment, (figure) 3-84
 - VLINE macro, 2-153
- Transparency feature, TERM macro, 2-122
- Transparent input records, 2-122
- TRUNK macro
- applicability, (table) 2-147
 - DDX PDN, 3-75
 - format, 2-146
 - operands, 2-146
 - packet-switched PDN, 3-72
 - PVC macro, 2-93
 - SUB macro, 2-105
 - use, 2-146
- Two-way alternate mode, 2-102
- TYPE operand
- CCA macro, 2-17
 - CONGRP macro, 2-23
 - JRNFILE macro, 2-44
 - LINE macro, 2-58
 - LOCAP macro, 2-78
 - PDN macro, 2-86
 - STATION macro, 2-102
 - VCGROUP macro, 2-149
 - VLINE macro, 2-155
- U**
- UDLC links, A-63
- UDLC/NRM networks
- link, configuring groups, 2-23
 - LPORT macro, 2-81
 - VLINE macro, 2-153
- UDLC stations, A-4
- UDUCT operand, BUFFERS macro, 2-9
- Unattended answering
- LINE macro, 2-63
 - VLINE macro, 2-156
- Unattended lines, reconnection, 2-68
- UNISCOPE
- CCA macro, 2-19
 - end-user communications, 3-38
 - LINE macro, 2-54
 - standard interface network definition, 3-14
 - TERM macro, 2-114, 2-126, 2-131, 2-142, 2-145
- Universal data link control, frame level address, 2-156
- UNIX
- DCA global networks, 3-53
 - VLINE macro, 2-151
- Unsolicited console type-ins, CCA macro, 2-19
- User data unit control table (UDUCT)
- specifying, 2-3, 2-9
 - statistic areas, 2-8
- User data unit control table (UDUCT), A-8
- User programs
- communications, loading, 5-6
 - establishing a session, 6-7
 - GUST, 5-7
- User-written programs, global networks with IMS 3-32
- USERS operand, CCA macro, 2-20
- USERTP operand, LPORT macro, 2-83
- UTS universal terminal systems
- configuring, B-1
 - end-user communications, 3-58
 - LINE macro, 2-55
 - standard interface network definition, 3-16
 - TERM macro, 2-115, 2-126, 2-131, 2-134
- (See also Terminals)

Index

V

- VCGROUP macro, 2-149
- Virtual channels, VLINE macro, 2-151, A-22
- Virtual circuit group, 2-149
- Virtual circuits
 - permanent (*See* Permanent virtual circuits)
 - switched (*See* Switched virtual circuits)
- Virtual lines
 - CONGRP macro, 2-23
 - general comments, A-63
 - global network configurations, 3-21
 - name, 2-104
 - station profile table, 2-102
- VLINE macro
 - applicability, (table) 2-152
 - DDX PDN, 3-77
 - format, 2-151
 - NORDIC PDN, 3-59, 3-62
 - operands, 2-153
 - packet-switched PDN, 3-72
 - PDN network definition, 3-58
 - Telcon network, A-22
 - use, 2-151

W

- Warm restart, 2-19
- WINDOW operand, STATION macro, 2-104
- Window size
 - flow control, data packets, 2-148
 - permanent virtual circuits, 2-94
 - switched virtual circuits, 2-108

Workstations

- configuring, 6-1
- generation and logon/sign-on procedures, (table) 6-2
- end-user communications, 3-38
- ICAM terminals, 6-4
- line buffer length, 2-67
- local (*See* Local workstations)
- logon, 6-8
- remote (*See* Remote workstations)
- startup procedures, 6-8
- WS operand, TRUNK macro, 2-148

X

- XEU statement, A-5
- XLATE operand
 - LINE macro, 2-71
 - TERM macro, 2-138
 - translation tables, 4-14
- X.21 circuit-switched PDN, LINE macro, 2-57, 2-63
- X.25 link access procedure, VLINE macro, 2-153

USER COMMENTS

We will use your comments to improve subsequent editions.

NOTE: Please do not use this form as an order blank.

(Document Title)

(Document No.)

(Revision No.)

(Update Level)

Comments:

From:

(Name of User)

(Business Address)



FOLD



NO POSTAGE
NECESSARY
IF MAILED IN THE
UNITED STATES

BUSINESS REPLY MAIL

FIRST CLASS PERMIT NO. 21 BLUE BELL, PA.

POSTAGE WILL BE PAID BY ADDRESSEE

Unisys Corporation
E/MSG Product Information Development
PO Box 500 — E5-114
Blue Bell, PA 19422-9990

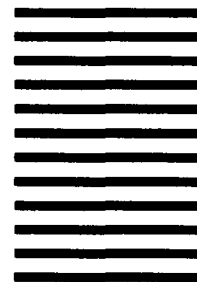

FOLD

USER COMMENTS

We will use your comments to improve subsequent editions

NOTE: Please do not use this form as an order blank.

(Document Title)

(Document No.)

(Revision No.)

(Update Level)

Comments:

From:

(Name of User)

(Business Address)

CUT

FOLD



NO POSTAGE
NECESSARY
IF MAILED IN THE
UNITED STATES

BUSINESS REPLY MAIL

FIRST CLASS PERMIT NO. 21 BLUE BELL, PA.

POSTAGE WILL BE PAID BY ADDRESSEE

Unisys Corporation
E/MSG Product Information Development
PO Box 500 — E5-114
Blue Bell, PA 19422-9990

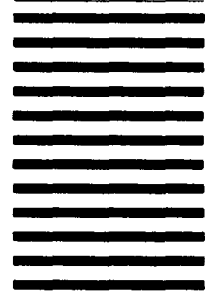

FOLD



