

Model 990 Computer Model 911 Video Display Terminal Installation and Operation

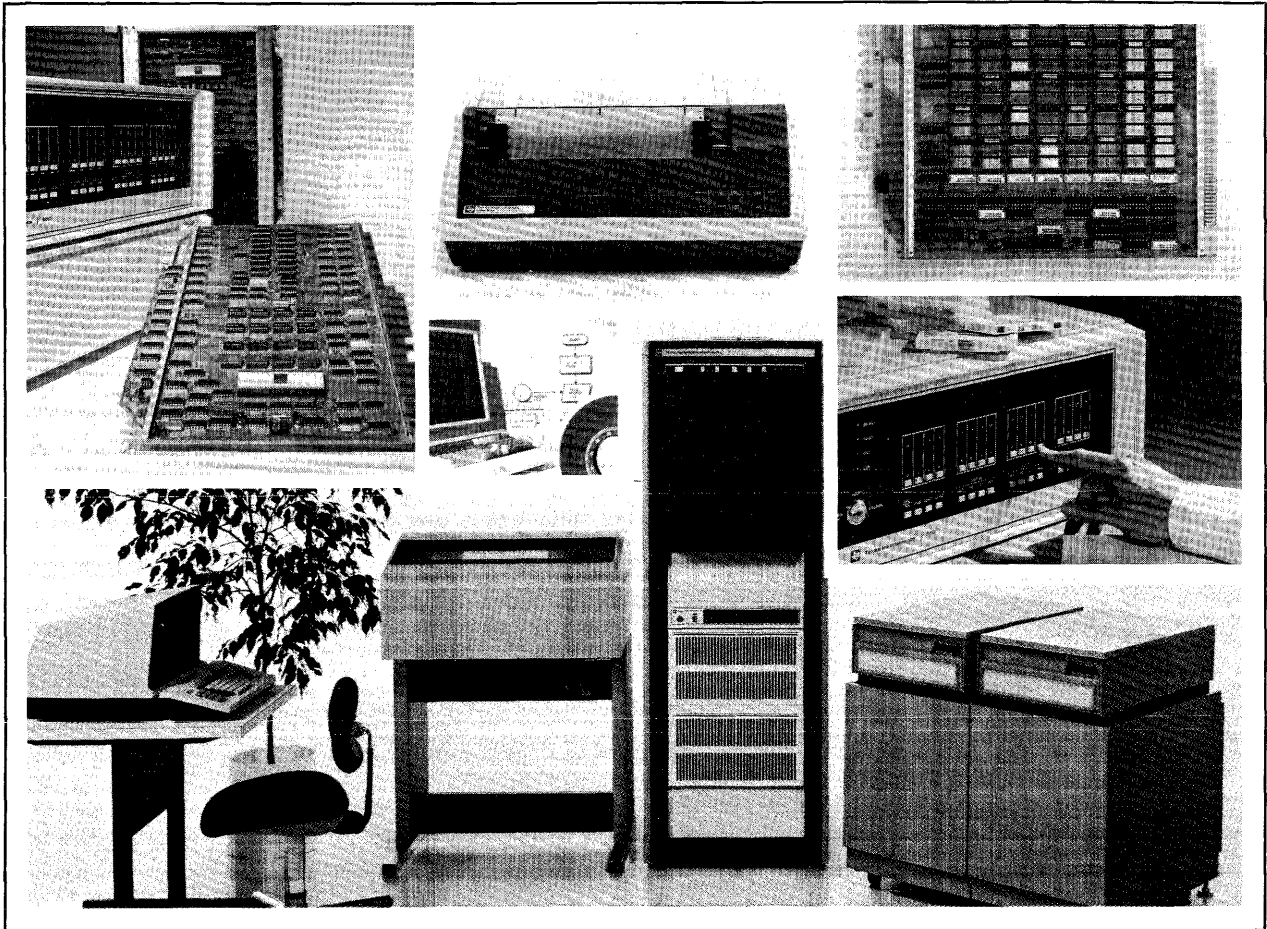

Part No. 945423-9701
15 January 1979

TEXAS INSTRUMENTS

We put computing within everyone's reach.

The information and/or drawings set forth in this document and all rights in and to inventions disclosed herein and patents which might be granted thereon disclosing or employing the materials, methods, techniques or apparatus described herein are the exclusive property of Texas Instruments Incorporated.

LIST OF EFFECTIVE PAGES

INSERT LATEST CHANGED PAGES DESTROY SUPERSEDED PAGES

Note: The portion of the text affected by the changes is indicated by a vertical bar in the outer margins of the page.

Model 990 Computer Model 911 Video Display
Terminal Installation and Operation (945423-9701)

Original Issue1 June 1977
Revised15 January 1979 (ECN 419643)

Total number of pages in this publication is 106 consisting of the following:

PAGE NO.	CHANGE NO.	PAGE NO.	CHANGE NO.	PAGE NO.	CHANGE NO.
Cover	.0				
Effective Pages	.0				
iii - viii.	.0				
1-1 - 1-10.	.0				
2-1 - 2-14.	.0				
3-1 - 3-20.	.0				
4-1 - 4-6.	.0				
Appendix A Div	.0				
A-1 - A-4	.0				
Appendix B Div	.0				
B-1 - B-4	.0				
Appendix C Div	.0				
C-1 - C-4	.0				
Appendix D Div	.0				
D-1 - D-4	.0				
Appendix E Div	.0				
E-1 - E-4	.0				
Appendix F Div	.0				
F-1 - F-6	.0				
Alphabetical Index Div.	.0				
Index-1 - Index-4.	.0				
User's Response	.0				
Business Reply	.0				
Cover Blank	.0				
Cover	.0				



PREFACE

This manual provides detailed instructions for installing the United States, European, and Japanese versions of the Texas Instruments Model 911 Video Display Terminal in conjunction with a properly installed Model 990 Computer. In addition it contains information required to program the computer to use the terminal and a description of the unit with specific attention to the controls and indicators. The information is divided into the following four sections:

- I General Description – This section briefly describes the features and major components of the terminal system to acquaint the reader with the system.
- II Installation – This section provides step-by-step instructions for unpacking and installing the terminal system in either a local or remote location. The procedures presuppose that the reader is not familiar with digital electronics.

If you do not choose to install the terminal yourself and would like one of Texas Instruments' service personnel to install the terminal, please contact your local Texas Instruments sales or service office. Either of these sources can also obtain for you additional information concerning the terminal should you decide to perform maintenance on the terminal.

- III Programming – This section presents interfacing information for use by a programmer in designing a service routine to control the terminal's activity.
- IV Operation – This section describes the controls and indicators of the terminal system for terminal operators. It includes not only keyboard information, but also terminal status and maintenance indicators so that the operator can determine if the terminal is operating properly. This section also provides instructions to enable operating personnel to perform preventive maintenance on the terminal.

APPENDIXES

- A. United Kingdom Model – This appendix contains information for United Kingdom Model 911 VDT keyboard and displayed character set.
- B. French Model – This appendix contains information for French Model 911 VDT keyboard and displayed character set.
- C. German Model – This appendix contains information for the German Model 911 VDT keyboard and displayed character set.
- D. Swedish/Finnish Model – This appendix contains information for the Swedish/Finnish Model 911 VDT keyboard and displayed character set.
- E. Norwegian/Danish Model – This appendix contains information for the Norwegian/Danish Model 911 VDT keyboard and displayed character set.
- F. Japanese Katakana Model – This appendix contains information for the Japanese Katakana Model 911 VDT keyboard and displayed character set.



TABLE OF CONTENTS

Paragraph	Title	Page
SECTION I. GENERAL DESCRIPTION		
1.1	General	1-1
1.2	System Terminology	1-2
1.2.1	Communications Register Unit (CRU)	1-2
1.2.2	VDT Controller	1-2
1.2.3	Display Unit	1-5
1.2.3.1	CRT Monitor	1-5
1.2.3.2	Power Supply	1-5
1.2.3.3	Control Logic	1-6
1.2.4	Keyboard	1-6
1.2.5	Interconnection Cable	1-6
1.3	Purpose of Equipment	1-7
1.4	Displayed Characters	1-7
SECTION II. INSTALLATION		
2.1	General	2-1
2.2	Site Requirements	2-1
2.2.1	Mounting Surface	2-2
2.2.2	Cabling Restrictions	2-2
2.3	Unpacking/Packing	2-3
2.4	Remote Installation Cable Routing	2-6
2.5	Terminal Installation	2-6
2.6	Connection to Computer	2-9
2.6.1	Location of Controller Circuit Board	2-9
2.6.2	Installing the Controller	2-9
2.6.3	Terminal Interrupt	2-12
2.6.4	Computer Power On	2-12
2.7	Terminal Checkout	2-12
SECTION III. PROGRAMMING		
3.1	General	3-1
3.2	Terminal Controller Interface	3-1
3.2.1	Input Interface	3-1
3.2.2	Output Interface	3-1
3.3	Screen Initialization	3-1
3.4	Keyboard Codes	3-6
3.5	Cursor	3-12
3.6	Sample Routines	3-12
3.6.1	Polling Routine	3-15
3.6.2	Read Keyboard	3-15
3.6.3	Echo Character to Screen	3-16



TABLE OF CONTENTS (Continued)

Paragraph	Title	Page
3.6.4	Read Character From Screen	3-17
3.6.5	Read Cursor Position	3-17
3.6.6	Restore Cursor Position	3-17
3.6.7	Move Cursor	3-17
3.6.8	Clear Screen	3-18
3.6.9	Roll Up Screen	3-19

SECTION IV. OPERATION

4.1	General	4-1
4.2	Keyboard.	4-1
4.3	Display Unit Controls and Indicators.	4-4
4.3.1	Control Panel	4-4
4.3.2	Data Indicators	4-4
4.3.3	VDT Controller Indicator	4-5
4.4	Operator Preventive Maintenance	4-5

LIST OF APPENDIXES

Appendix	Title	Page
A	United Kingdom Model 911 VDT Keyboard Arrangement, Hexadecimal Codes, Mode Character Positions, ASCII, and Special Character Set	A-1
B	French Model 911 VDT Keyboard Arrangement, Hexadecimal Codes, Mode Character Positions, ASCII, and Special Character Set	B-1
C	German Model 911 VDT Keyboard Arrangement, Hexadecimal Codes, Mode Character Positions, ASCII, and Special Character Set	C-1
D	Swedish/Finnish Model 911 VDT Keyboard Arrangement, Hexadecimal Codes, Mode Character Positions, ASCII, and Special Character Set	D-1
E	Norwegian/Danish Keyboard Arrangement, Hexadecimal Codes, Mode Character Positions, ASCII, and Special Character Set	E-1
F	Japanese Katakana Keyboard Arrangement, Hexadecimal Codes, Mode Character Positions, Modified ASCII (JIS-8), Special Character Set, and Additional Eight-Bit Displayed Character Set	F-1



LIST OF ILLUSTRATIONS

Figure	Title	Page
1-1	Model 911 Video Display Terminal	1-2
1-2	Model 911 VDT Standard Configuration	1-3
1-3	Major Terminal System Components	1-4
1-4	Model 911 VDT Controller Block Diagram	1-4
1-5	United States Standard Keyboard Arrangement	1-6
1-6	United States Model 911 VDT Displayed Character Set, Including Graphics Symbols	1-8
1-7	Model 911 VDT International Displayed Characters	1-10
2-1	Terminal Physical Dimensions	2-1
2-2	Model 911 Video Display and Keyboard Shipping Container	2-4
2-3	Keyboard Shipping Container	2-5
2-4	Basic Terminal Kit	2-7
2-5	Model 911 VDT Kit Cabling Configurations	2-8
2-6	Typical Model 911 VDT Controller Board	2-11
3-1	Computer Input Bit Assignments for Terminal 0	3-2
3-2	Computer Input Bit Assignments for Terminal 1	3-3
3-3	Displayed Character Positions	3-5
3-4	Computer Output Bit Assignments for Terminal 0	3-7
3-5	Computer Output Bit Assignments for Terminal 1	3-8
3-6	Keyboard Showing Lowercase Mode Character Positions and Hexadecimal Codes	3-14
3-7	Keyboard Showing Uppercase Mode Character Positions and Hexadecimal Codes	3-14
3-8	Keyboard Showing Control Character Positions and Hexadecimal Codes	3-14
3-9	Keyboard Showing Shift Mode Character Positions and Hexadecimal Codes	3-15
4-1	United States Model 911 Keyboard	4-2
4-2	Display Unit Control Panel	4-3
4-3	Data Indicator Locations	4-3
4-4	Data Indicators Sample Pattern	4-4

LIST OF TABLES

Table	Title	Page
1-1	VDT Display Characteristics	1-5
2-1	Terminal Site Installation Requirements	2-2
2-2	VDT Controller Standard Configurations	2-10
2-3	Addresses Assigned to CRU Expansion Chassis	2-11



LIST OF TABLES (Continued)

Table	Title	Page
3-1	Model 911 VDT Controller Addressable Input Bits	3-4
3-2	Built-In Test Input Signals.	3-6
3-3	Model 911 VDT Controller Addressable Output Bits	3-9
3-4	Built-In Test Keyboard Simulation Data	3-12
3-5	United States Keyboard Codes.	3-13
4-1	United States and European Keyboard Mode Selection	4-2
4-2	Japanese Katakana Keyboard Mode Selection	4-2



SECTION I

GENERAL DESCRIPTION

1.1 GENERAL

The Texas Instruments Model 911 Video Display Terminal (figure 1-1) is a versatile communications terminal that provides maximum operator convenience in a distinctively styled package. The terminal incorporates the following features that enhance operation:

- Separate keyboard to facilitate placing the keyboard in the most convenient position for the operator
- Upper- and lower-case gothic character set
- 32-character graphic drawing set (1920-character display only)
- Katakana character set (Japanese Katakana model only)
- Instant data display capability to allow the computer to display immediately a full screen with information
- A special-function bit that accompanies each character in memory, specifies whether the character is displayed at dual (high or low) intensity, and indicates such things as a protected field if used as a software flag (feature not available on Japanese Katakana model)
- Standard typewriter keyboard
- Numeric pad to facilitate entry of numerical quantities
- Programmable function keys.

In addition to these operator features, the terminal provides programmable cursor positioning and editing functions, a self-contained refresh memory plus a full-ASCII keyboard with additional function keys suited to the specific application. The Japanese model keyboard has a KANA mode key to select 64-character Katakana set.

The Model 911 Video Display Terminal (VDT) kit is a peripheral unit that communicates with the Model 990 Computer via the Communications Register Unit (CRU) serial data bus. The kit consists of the following components:

- Model 911 VDT Assembly, Part Number 946075
- Model 911 Keyboard Assembly, Part Number 948560
- Interconnection cable, United States and Japan (unshielded), Part Number 948561; European (shielded), Part Number 936500
- Model 911 VDT Controller, United States and European, Part Number 946076
- Model 911 VDT Controller, Japanese, Part Number 2263490.

Figure 1-2 illustrates the standard configuration for the Model 911 VDT kit.



135978 (911-477-39-3)

Figure 1-1. Model 911 Video Display Terminal

Optional components available for the Model 911 VDT include:

- Extension cable assembly, Part Number 946093
- Extension cable kit, Part Number 936503

1.2 SYSTEM TERMINOLOGY

Figure 1-3 illustrates the relationship of the major components of the VDT system. The following paragraphs describe the function of each of the components to provide an understanding of system operation.

1.2.1 COMMUNICATIONS REGISTER UNIT (CRU). The Communications Register Unit (CRU) is the serial interface of the Texas Instruments Model 990 Computer. Data is transmitted between the controller and the computer through this interface one bit at a time (each character on the keyboard generates eight data bits). This transfer occurs so rapidly that no delay is apparent to the operator. Status from the controller and control information from the computer also use this interface.

1.2.2 VDT CONTROLLER. The Model 911 VDT Controller is implemented on a full-size printed wiring board that fits into one of the chassis locations of a Model 990 family computer or a Model 990 family computer expansion chassis. Depending on the selected option, the controller is actually one or two autonomous controllers that share a common CRU interface and time-base generator.

The controller receives data from the computer and the terminal keyboard and stores screen symbol data in a self-contained display-image memory. The controller reads the data from its memory and generates a signal pattern to write that data onto the VDT screen. Data is continually rewritten on the screen for image refresh.

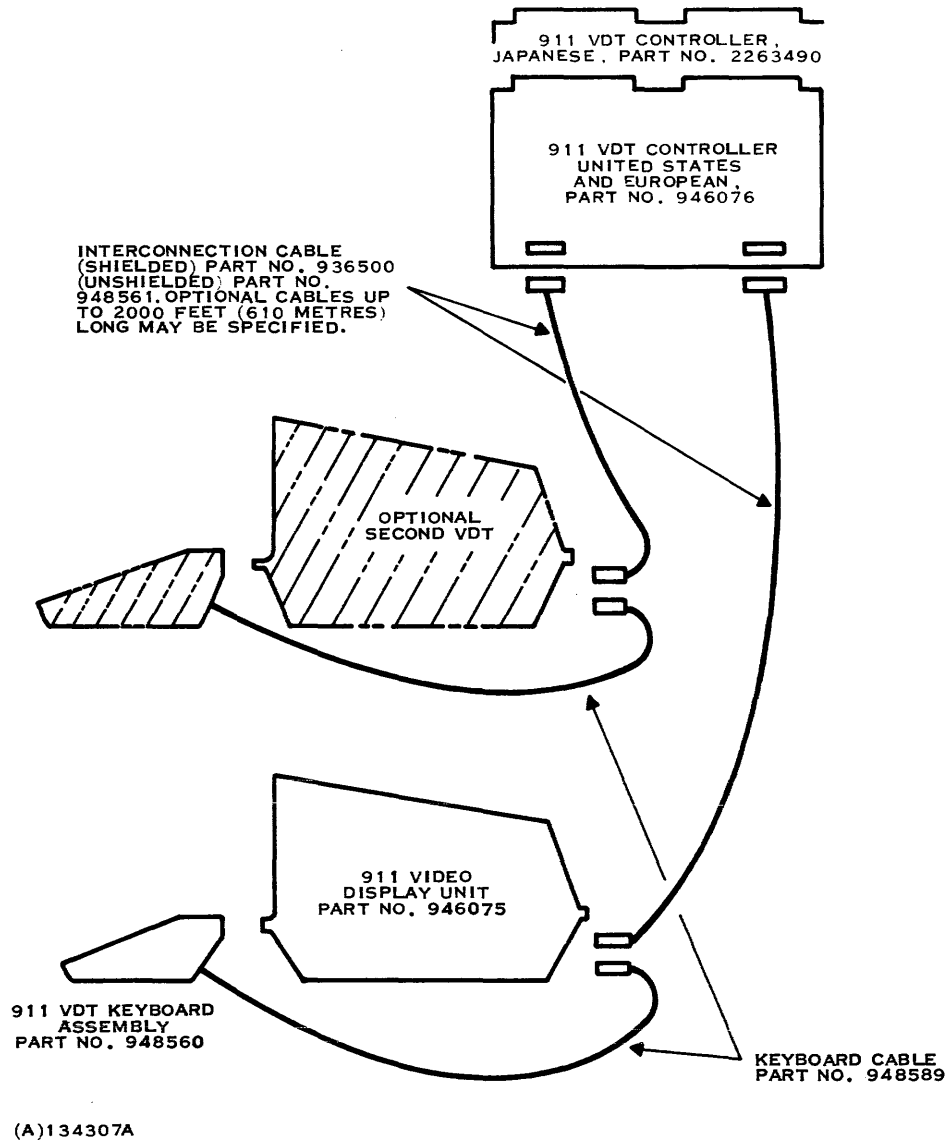

Figure 1-2. Model 911 VDT Standard Configuration

Display characteristics such as refresh rate (50- or 60-hertz), character capacity (1920 or 960 characters), and alphanumeric character set (display symbols) are specified by read-only memory (ROM). Graphic character generator logic is only available in the 1920-character display.

Standard VDT controller options include:

- Single-display, 960-character capacity
- Dual display, 960-character capacity
- Single display, 1920-character capacity
- Dual display, 1920-character capacity.

Figure 1-4 is a simplified block diagram of the VDT controller.

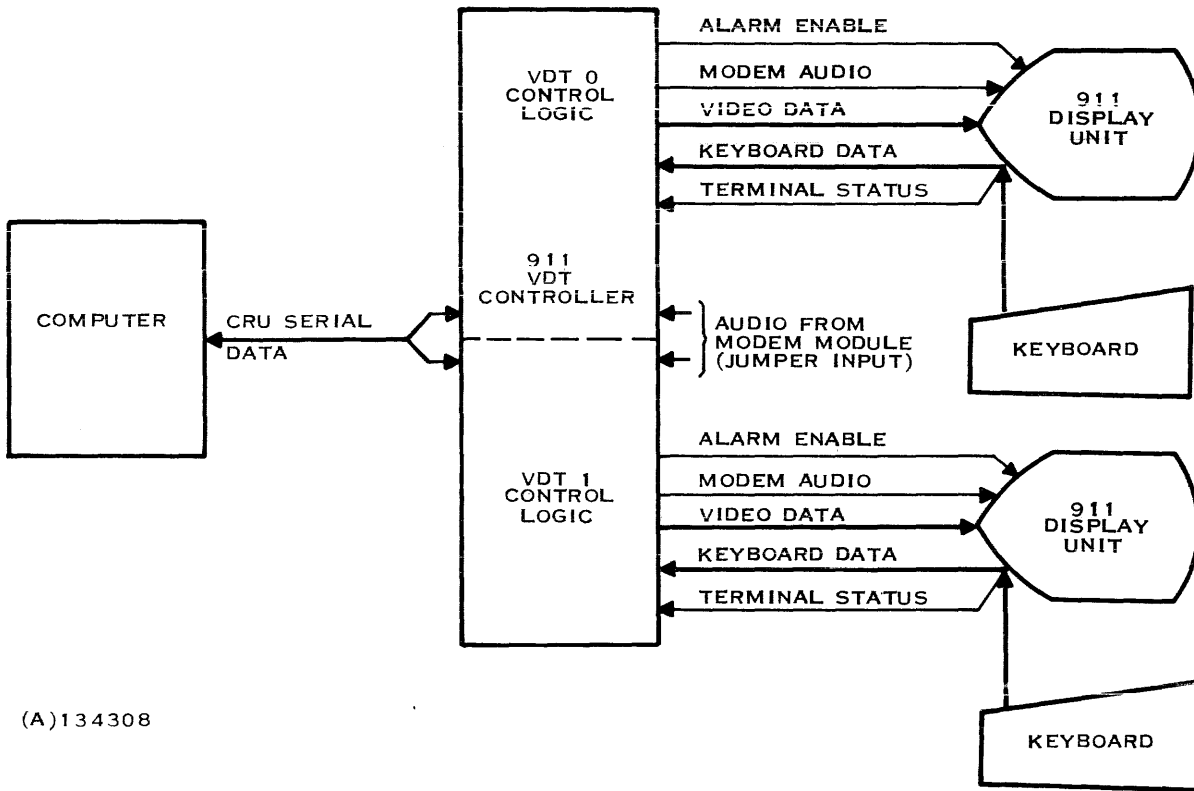

(A)134308

Figure 1-3. Major Terminal System Components

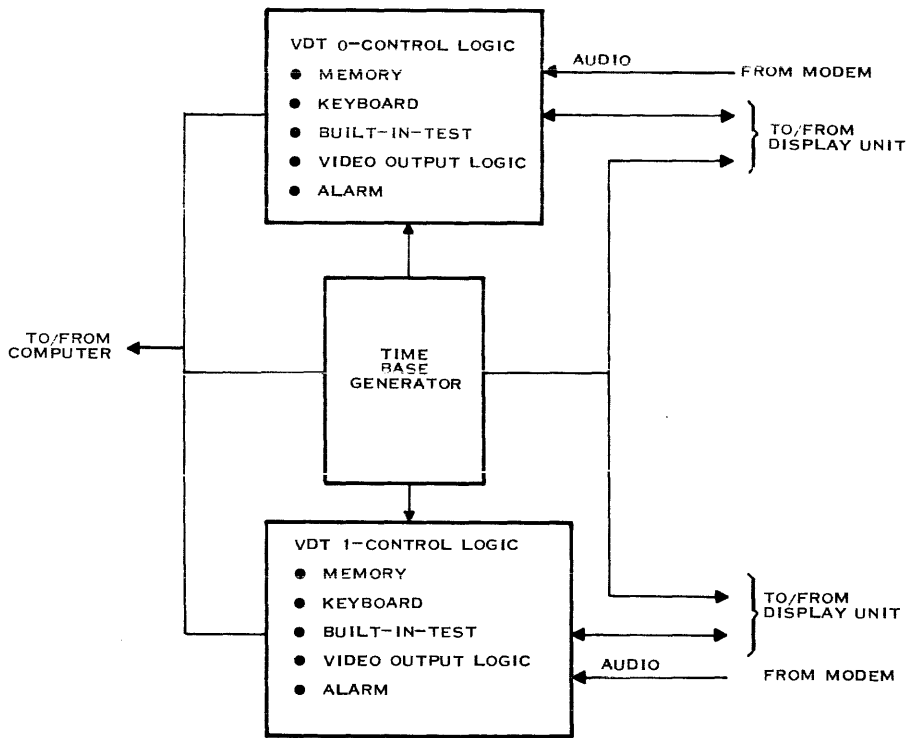

(A)134309

Figure 1-4. Model 911 VDT Controller Block Diagram



1.2.3 DISPLAY UNIT. The display unit houses a 305-millimetre (12-inch) cathode-ray tube (CRT) monitor, power supply, control logic, audible alarm logic, and two controls to allow the operator to adjust the brightness of the display and the volume of the audible alarm.

1.2.3.1 CRT Monitor. The CRT monitor is a 305-millimetre (12-inch) monitor with a selectable capacity of 12 or 24 lines of information containing 80 characters each. The monitor produces alphanumeric and graphic display characters using the television raster scan technique. Table 1-1 lists the principle display characteristics.

Functionally, the display is characterized by the following features:

- Alphabetic, numeric, and special (+, -, *, etc.) character set
- Katakana character set (Japanese Katakana model only)
- Graphic character set (1920-character display)
- 960- or 1920-character formats
- Software-selectable cursor blinking
- Gothic font upper- and lower-case characters
- Dual intensity display (not on Japanese Katakana model).

1.2.3.2 Power Supply. The power supply in the display unit consists of a power transformer mounted on the display unit base and regulators on the logic board mounted at the rear of the display unit.

Table 1-1. VDT Display Characteristics

Description	960 Characters		1920 Characters	
	50 Hz	60 Hz	50 Hz	60 Hz
Character Matrix – Columns	5	5	5	5
– Rows	7	7	7	7
Character Block – Columns	7	7	7	7
– Rows	16	16	10	10
Frame (refresh) Rate	50	60	50	60
Lines of Characters	12	12	24	24
Character Rate (Dot rate divided by dots per character in MHz)	1.57	1.57	1.57	1.57
Characters per row	80	80	80	80
Video Display Horizontal Size				
Millimetres - tolerance ± 6.35	215.90	215.90	215.90	215.90
(Inches - tolerance ± 0.25)	(8.50)	(8.50)	(8.50)	(8.50)
Video Display Vertical Size				
Millimetres - tolerance ± 6.35	139.70	139.70	139.70	139.70
(Inches - tolerance ± 0.25)	(5.50)	(5.50)	(5.50)	(5.50)



1.2.3.3 **Control Logic.** The control logic on the printed wiring board at the rear of the display unit contains logic that supports the display function, provides an interface between keyboard and VDT controller, and drives the audible alarm.

1.2.4 **KEYBOARD.** A separate keyboard connects to the display unit by a 1.52-metre (5-foot) cable. The four-mode keyboard provides the 128-character ASCII code set and additional eight-bit codes for special functions. The Japanese keyboard has two additional modes for generating the Katakana character set. A key on the Japanese keyboard selects alphanumeric or Katakana character set. The key at the left of the space bar configures the Japanese keyboard for generation of the Katakana code set.

The 911 keyboard consists of a basic alphanumeric keyboard, numeric pad, cursor pad, and a function key array. Figure 1-5 illustrates the United States keyboard arrangement. Key caps are removable and may be replaced to provide custom legends for special applications such as international formats. (Refer to the appendixes for illustrations of international formats.)

1.2.5 **INTERCONNECTION CABLE.** The interconnection cable joins the display unit and the VDT controller. The standard cable is 5 metres (16.4 feet) long and consists of coaxial cable for video and seven signal lines (six conductors in balanced pair configuration and one single-ended conductor). Optional cables are available to provide a maximum separation of 610 metres (2000 feet).

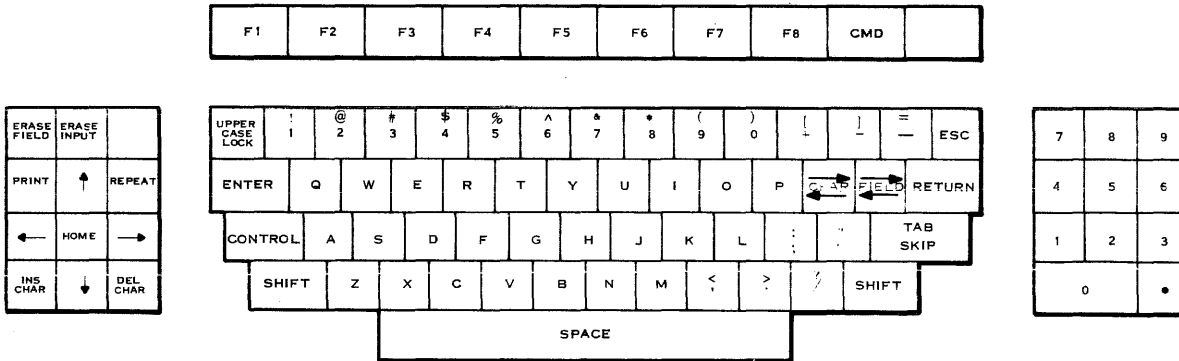

(B)134310

Figure 1-5. United States Standard Keyboard Arrangement



1.3 PURPOSE OF EQUIPMENT

The Model 911 Video Display Terminal provides two-way communication between the VDT operator and the computer system. The VDT controller can be inserted into any available CRU chassis location in the computer or expansion chassis. Together with the appropriate software installed in the computer, the VDT allows the operator to perform the following functions:

- View the video display presented by the computer
- Enter data for display from the keyboard
- Edit any of the entered data as desired through the use of the controlling computer program
- Store the display contents in computer memory for use by other peripheral devices (printer, modem, etc.)
- Initiate special functions such as terminal self-test, print line, or scroll display. These functions are activated by the program in response to input of a special keyboard character code, or alternately, by entry of a control character at the keyboard.

1.4 DISPLAYED CHARACTERS

Figure 1-6 illustrates the United States character set that is generated by the Model 911 VDT controller and displayed on the CRT screen. Figure 1-7 illustrates the international set of characters not illustrated in figure 1-6. Refer to Appendix F, figure F-9, for the additional 128 eight-bit Japanese Katakana displayed character set.

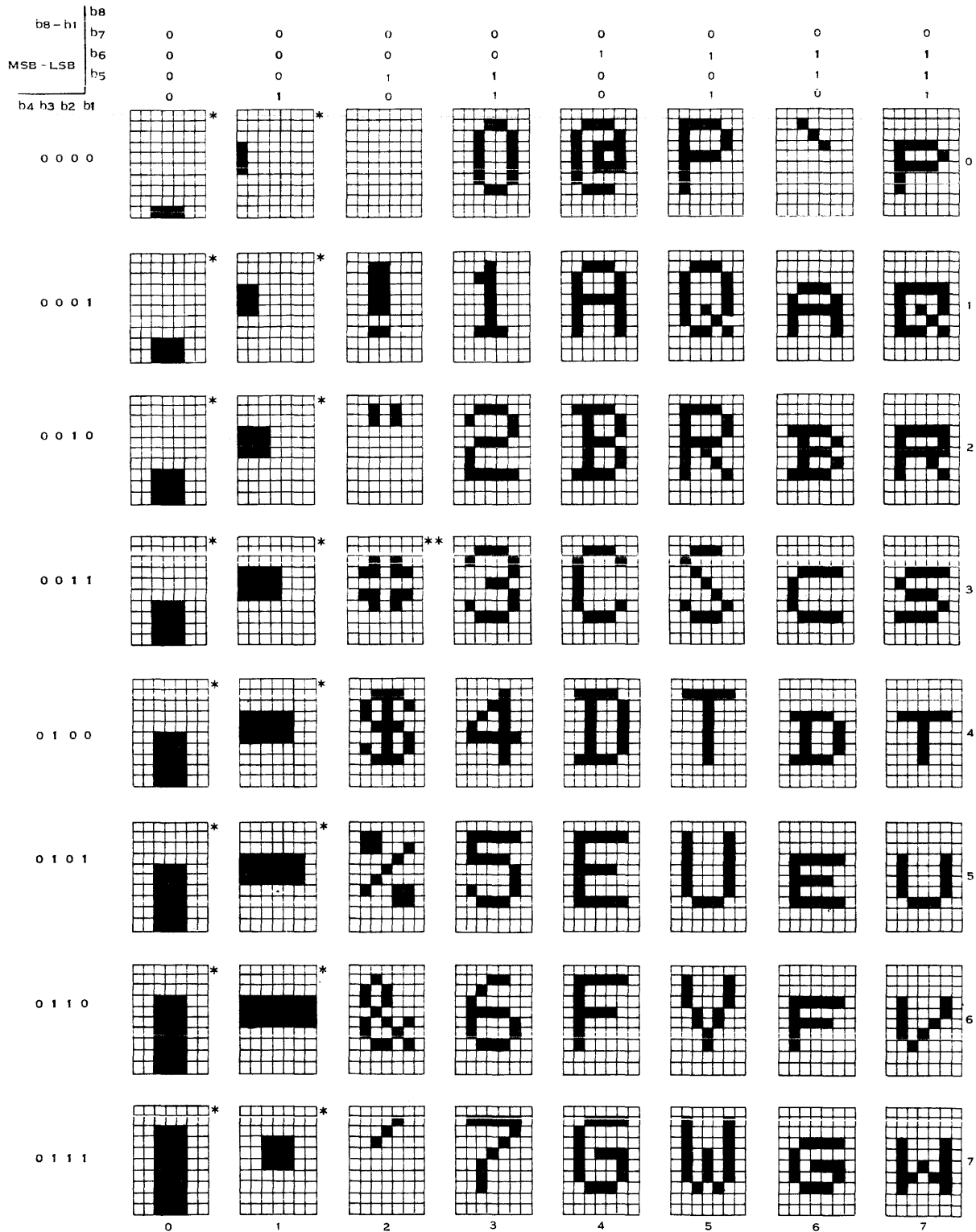

(B)136296A(1/2)

* GRAPHICS (1920-CHARACTER DISPLAY ONLY)

** REFER TO FIGURE 1-7 FOR EUROPEAN AND JAPANESE CHARACTERS THAT VARY FROM THOSE SHOWN.

Figure 1-6. United States Model 911 VDT Displayed Character Set, Including Graphics Symbols (Sheet 1 of 2)



MSB-LSB	b8	0	0	0	0	0	0	0	0
b8-b1	b7	0	0	0	0	1	1	1	1
b6	0	0	1	1	0	0	1	1	1
b5	0	1	0	1	0	1	0	1	1
b4 b3 b2 b1									
1 0 0 0									8
1 0 0 1									9
1 0 1 0									A
1 0 1 1									B
1 1 0 0									C
1 1 0 1									D
1 1 1 0									E
1 1 1 1									F

(B)136296 (2/2)

* GRAPHICS (1920-CHARACTER DISPLAY ONLY)

** REFER TO FIGURE 1-7 FOR EUROPEAN AND JAPANESE CHARACTERS THAT VARY FROM THOSE SHOWN.

Figure 1-6. United States Model 911 VDT Displayed Character Set, Including Graphics Symbols (Sheet 2 of 2)

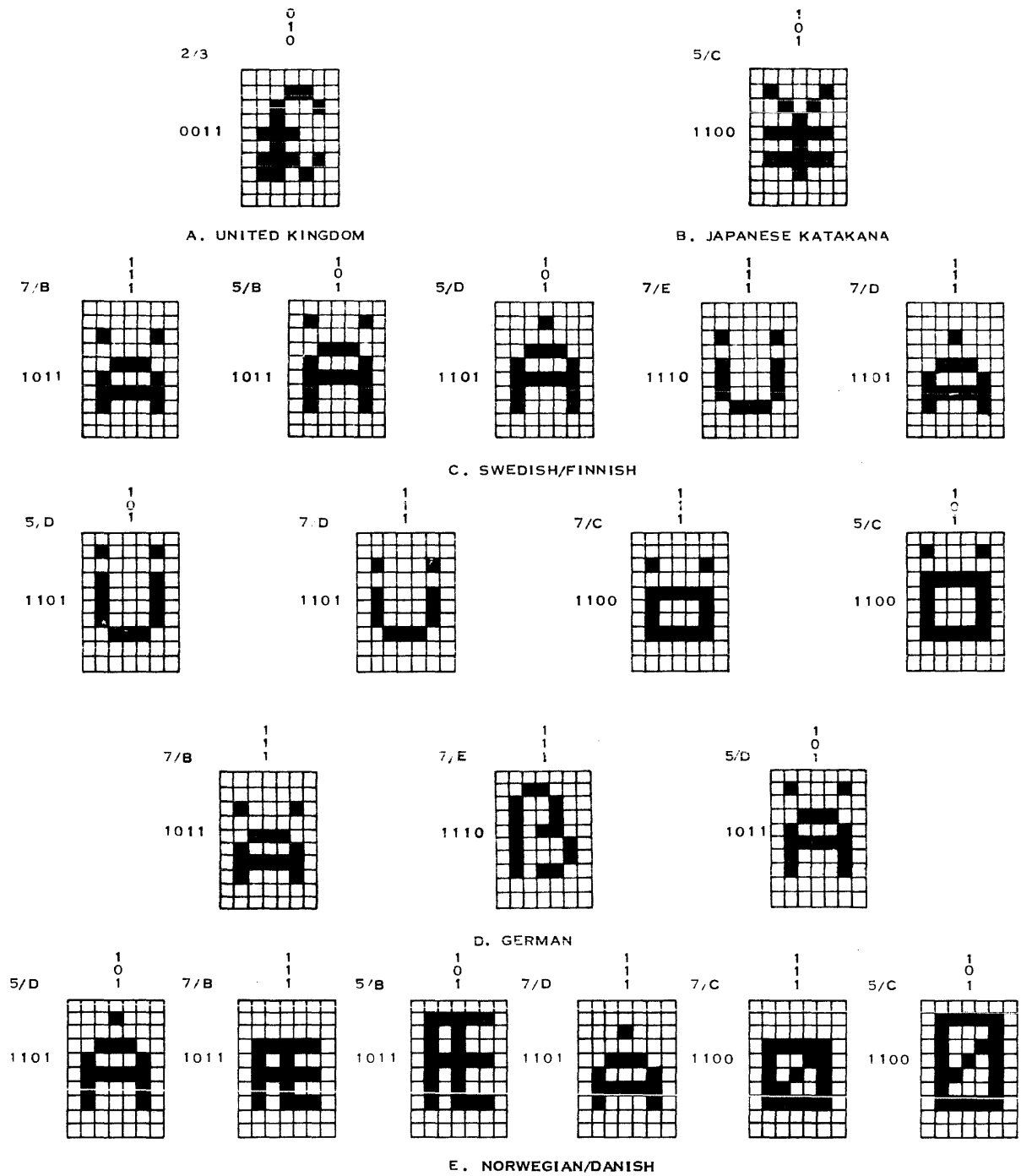

(B) 140750

Figure 1-7. Model 911 VDT International Displayed Characters



SECTION II

INSTALLATION

2.1 GENERAL

This section provides information for planning the installation site, unpacking and packing the terminal, installing the terminal and controller at the site, and ensuring that the terminal is operating properly. The instructions in this section require a moderate familiarity with cabling technique and use of common handtools, but do not assume any level of expertise in digital electronics.

2.2 SITE REQUIREMENTS

Because the keyboard is separate from the display portion of the terminal, the terminal can be mounted in several configurations to suit the needs of the operating environment. The installation site must, however, conform to the physical dimensions of the terminal as illustrated in figure 2-1. Table 2-1 summarizes some of the requirements. The following paragraphs explain their significance.

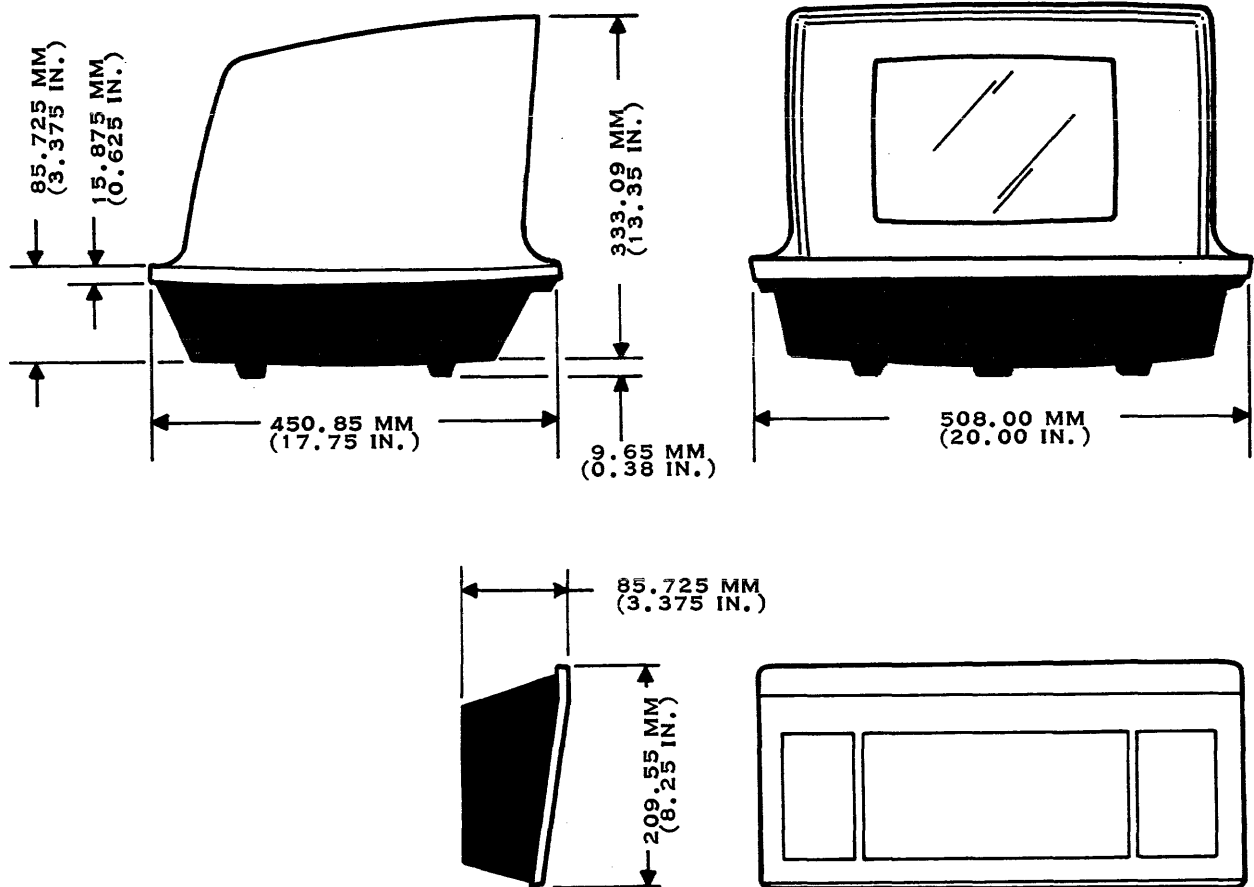

(A)134311A

Figure 2-1. Terminal Physical Dimensions



Table 2-1. Terminal Site Installation Requirements

Requirement	Display Only	Keyboard Only	Display/Keyboard
Minimum Width	508 mm (20 in.)	508 mm (20 in.)	508 mm (20 in.)
Minimum Depth	483 mm (19 in.)	216 mm (8.5 in.)	711 mm (28 in.)
Minimum Vertical Clearance	345 mm (13.6 in.)	Free access to keys (keyboard is 102 mm (4 in.) high)	343 mm (13.5 in.)
Recommended Height of Mounting Surface from Floor:			
Seated Operator	711 to 914 mm (28 to 36 in.)	711 mm (28 in.)	711 mm (28 in.)
Standing Operator	1067 to 1270 mm (42 to 50 in.)	1067 mm (42 in.)	1067 mm (42 in.)
Operating Temperatures	0°C to 40°C* (32°F to 104°F*)	0°C to 40°C* (32°F to 104°F*)	0°C to 40°C* (32°F to 104°F*)
Operating Humidity	5% to 95%	5% to 95%	5% to 95%
Altitude	3048 metres (10,000 feet)	3048 metres (10,000 feet)	3048 metres (10,000 feet)

*At sea level. Derate to 32°C (90°F) at 3048 metres (10,000 feet).

2.2.1 MOUNTING SURFACE. The VDT components require adequate mounting space on a flat, horizontal surface. The space must allow room at the rear of the display unit for cable connections, clearance at the front of the display unit for adequate viewing, and operator access to the front of the keyboard. The mounting surface must be free of any material that could block the ventilation louvers on the underside of the display unit. Consideration of the operator's normal position (sitting or standing) when using the terminal determines the height of the mounting surface.

2.2.2 CABLING RESTRICTIONS. Cable lengths affect the positioning of the equipment at the site. If the keyboard is operated as a separate unit from the display, it must remain within 1.52 metres (5 feet) of the keyboard input connector on the rear of the display due to the length of the cable. This restriction also ensures that the operator can clearly view the display screen. In addition, the display unit must be within 1.83 metres (6 feet) of a grounded outlet for input power. The display can be positioned up to 5 metres (16.4 feet) away from the controlling Model 990 Computer through the use of a single basic cable assembly. Distances in excess of 5 metres (16.4 feet) up to a maximum of 610 metres (2000 feet) from the computer can be achieved through the use of an optional extension cable assembly. The extension cable assembly (Part Number 946093)



includes mounted connectors and is used for open floor installations. The extension cable kit (Part Number 936503) provides cable and separate connector kits for final assembly after the cable has been routed through the walls or cable tray.

2.3 UNPACKING/PACKING

The display unit and keyboard are shipped in a corrugated cardboard container system as illustrated in figures 2-2 and 2-3. The VDT controller circuit board and the interconnecting cables may either be packed in the accessory box shown in figure 2-3 or in the container containing the computer (if the terminal is shipped as a part of a computer system). Upon receipt of the container, inspect it to ensure that no signs of physical damage are present. Following this preliminary inspection, perform the following steps to remove the equipment from the container and prepare it for operation.

NOTE

Save shipping carton and all packing materials for use in reshipment of the unit.

1. Position container so that the address label is right-side up.
2. Slit tape along container flag seams and open container.
3. Grasp accessory box by its sides and lift out of container.
4. Open accessory box and remove contents, which may include manuals, VDT controller, and interface cables, depending on configuration shipped.
5. Set contents of accessory box aside in a safe place.
6. Grasp keyboard box by its sides and lift out of container.
7. Open keyboard box.
8. Grasp keyboard by front and rear edges and lift keyboard and foam end caps out of box.
9. Place keyboard and end caps on a table or other supporting surface. Supporting keyboard from underneath, slip end caps off.
10. Return keyboard end caps to keyboard box and set box aside.
11. Lift top half of foam block off display assembly and set aside.
12. Grasp display assembly by front and rear where base and top meet, and lift out of remaining foam block. Set display assembly in desired location.
13. Return all packing materials to boxes and repack boxes into shipping container. Store for possible reshipment.

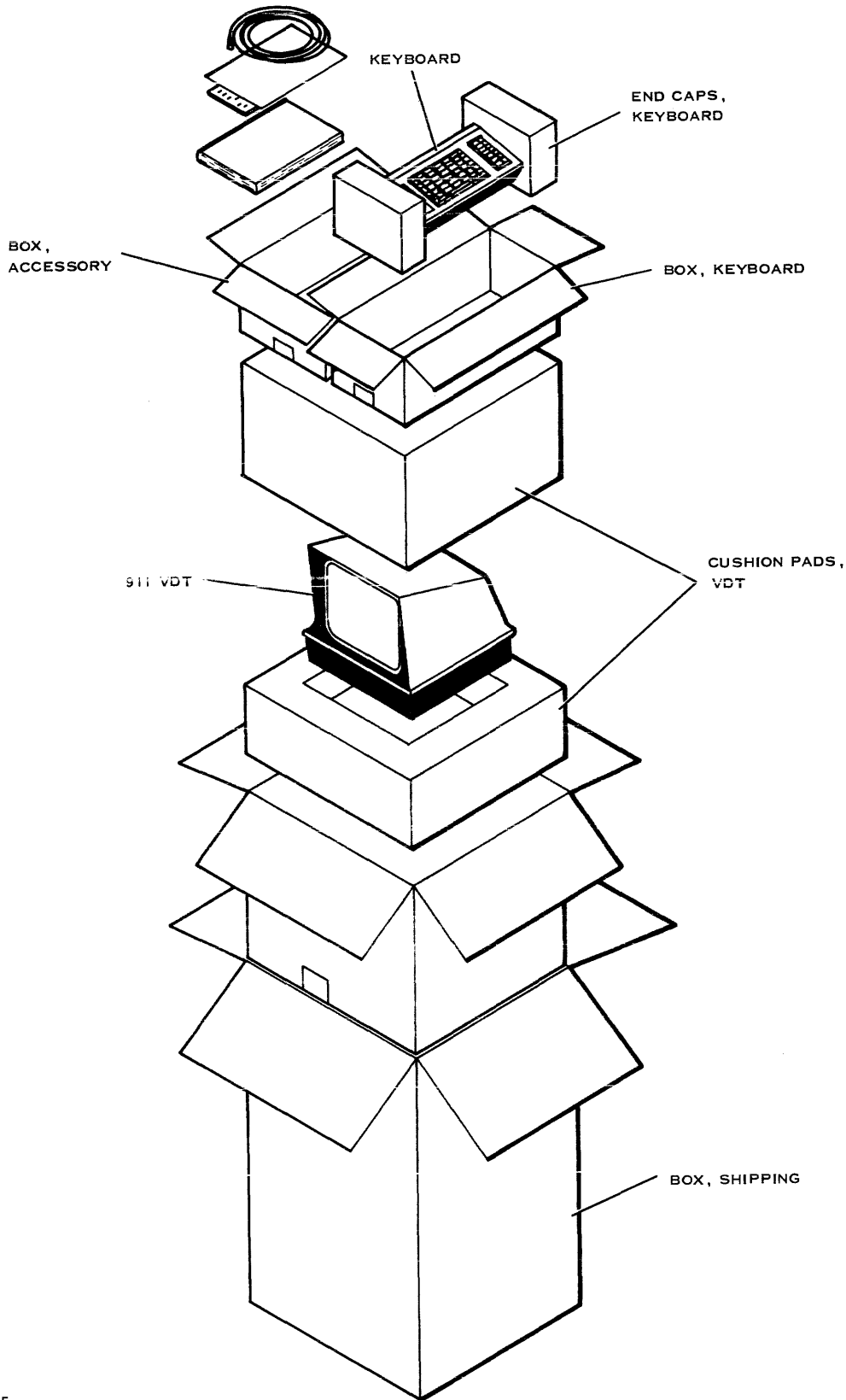

(B) 140925

Figure 2-2. Model 911 Video Display and Keyboard Shipping Container



945423-9701

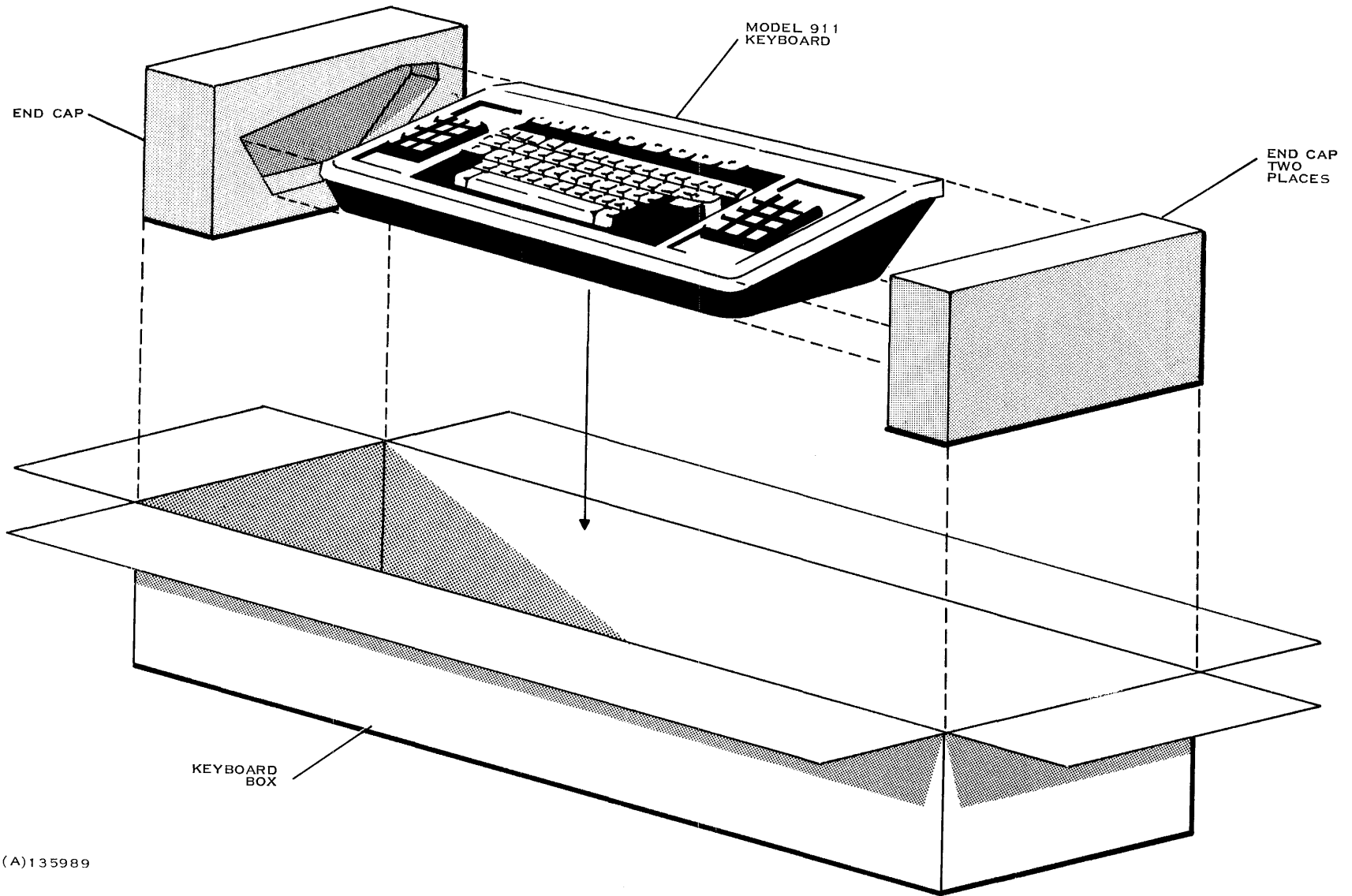

(A)135989

Figure 2-3. Keyboard Shipping Container



2.4 REMOTE INSTALLATION CABLE ROUTING

If the terminal is ordered to be installed at a distance greater than 5 metres (16.4 feet) from the controlling 990 computer, an additional cable is included in the shipping containers.

This cable must be routed from the terminal installation site to within 5 metres (16.4 feet) of the controlling computer before continuing with the installation procedure. Observe the following rules when routing the cable through the facility.

1. Do not route the cable in conduit that also houses ac power lines.
2. Do not route the cable through damp or wet areas.
3. Do not route the cable across traffic areas unless the cable is protected with a rigid wireway.
4. Allow sufficient slack at each end of the cable for easy connection of the cable to the display unit and to the controller cable.

2.5 TERMINAL INSTALLATION

Perform the following procedure to install the display unit and keyboard at the site selected for it:

1. Ensure that all required terminal components are present as illustrated in figure 2-4.
2. Place the display unit in the desired location.

NOTE

The ON/OFF switch is located on the right side of the display unit.

3. Set the ON/OFF switch to the OFF position.
4. Remove the cable tie from the ac power cord (at the back of the display unit) and connect the power cord to a grounded ac receptacle.
5. Place the keyboard in the desired location.
6. Remove the cable tie from the keyboard cable, route the cable to the rear of the display unit, and connect the cable to jack J1 (KYBD) on the rear of the display unit.

NOTE

The terminal can be installed in one of two configurations depending upon the distance between the terminal and the controlling computer. Figure 2-5 illustrates the cable connections required for each configuration.



945423-9701

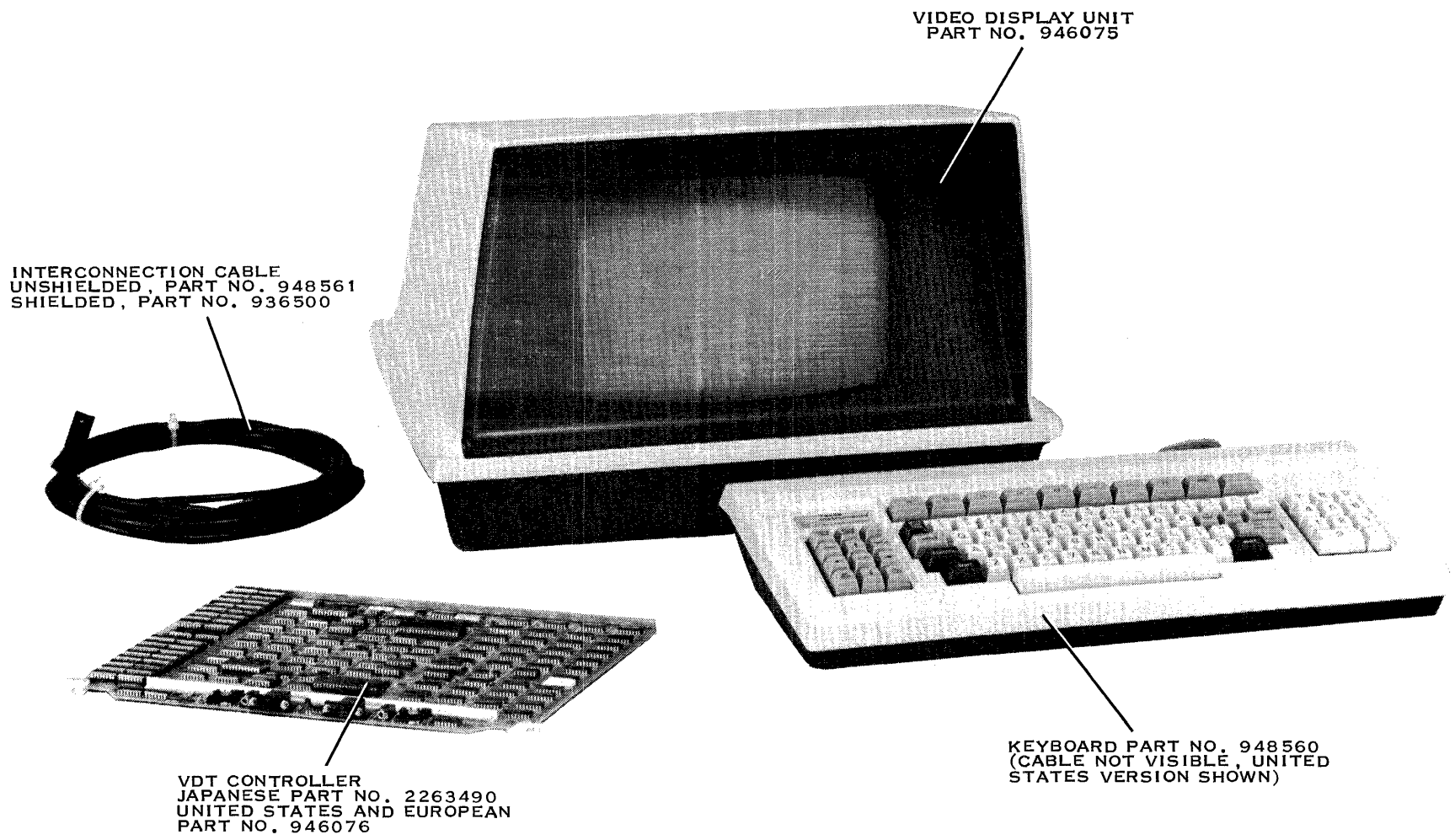

(A) 135978 (911-477-39-3)

Figure 2-4. Basic Terminal Kit



ONLY J4 AVAILABLE ON SINGLE-CONTROLLER PWB (LOWEST BASE ADDRESS)

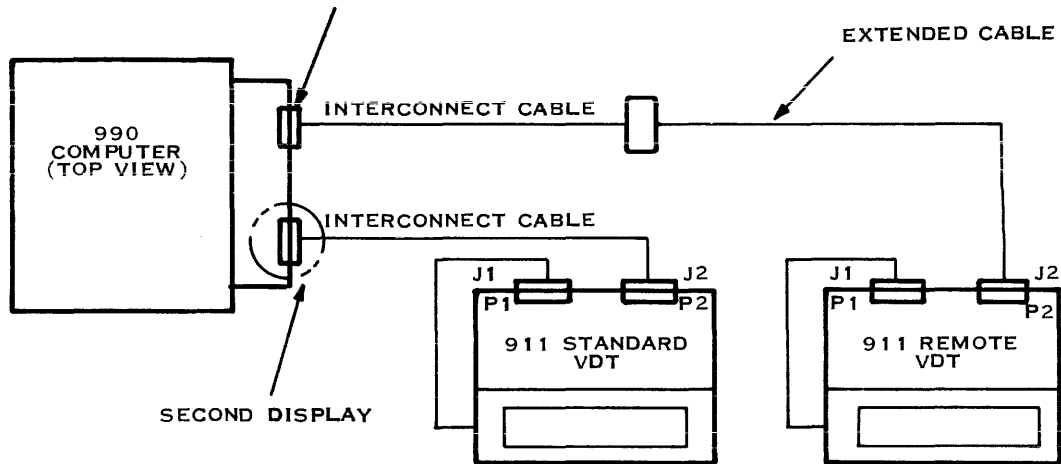

BUILDING ROUTED CABLE IS CUSTOMER DEFINED. CONNECTORS ARE ATTACHED DURING INSTALLATION.

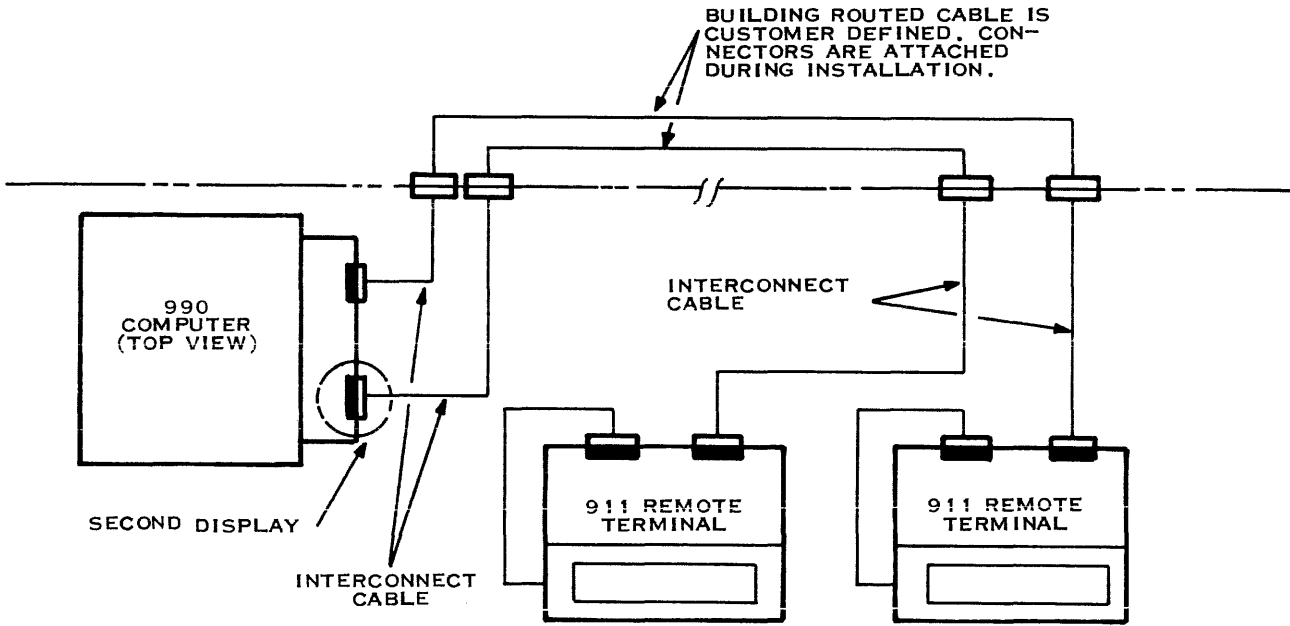

NOTE: SHIELDED INTERCONNECT CABLE PART NO. 936500 AFFORDS SHIELDED TERMINATION BY CONNECTING THE CABLE PIGTAIL TO THE FAST-ON CONNECTOR ON THE COMPUTER CHASSIS. THE FAST-ON CONNECTOR IS WALL-MOUNTED IN REMOTE LOCATIONS.

(A)134315A

Figure 2-5. Model 911 VDT Kit Cabling Configurations



7. Connect plug P2 (9-pin socket) of the data cable to jack J2 on the rear of the display unit.
8. On the power supply/logic board in the display unit is a video compensation circuit. This circuit has two gain settings selected by switch or jumper plug configuration. Remove the top cover of the VDT for access to the gain selector.
9. Set the video compensation circuit to the L position if the length of the cables between the terminal and the computer is 305 metres (1000 feet) or more; otherwise, configure the circuit to the S position.

NOTE

The video compensation circuit should be set for optimum display clarity regardless of cable length.

2.6 CONNECTION TO COMPUTER

The VDT controller circuit board may be installed in either the main chassis of the computer or in an expansion chassis that is connected to the computer. In all cases the computer and/or expansion chassis equipment must be installed and operating properly. Refer to the Computer System Hardware Reference Manual for computer installation instructions. Before installing the VDT controller circuit board, reference table 2-2 to verify that the controller on hand supports the associated VDT(s).

2.6.1 LOCATION OF CONTROLLER CIRCUIT BOARD. The physical location of the circuit board within either the computer or the expansion chassis determines the CRU address that the controller circuit board responds to. Therefore, before deciding upon a chassis location for the new circuit board, determine the address that the system software expects it to recognize. Refer to the configuration label on the top of the computer chassis to determine the location in the chassis corresponding to the expected address. Refer to table 2-3 to determine the expansion chassis corresponding to the base address.

2.6.2 INSTALLING THE CONTROLLER. Once the proper location for the VDT controller circuit board has been determined, the controller may be installed in the computer or expansion chassis and connected to the terminal cables. Perform the following steps to complete that procedure:

1. Set the POWER switch on the front of the computer or expansion chassis to the OFF position to remove ac power from the unit.

NOTE

The VDT controller circuit board (figure 2-6) has two plastic pivoted tabs (card ejectors) on the end of the board. This end is the outside edge of the circuit board. The opposite edge of the circuit board inserts into the connectors in the computer chassis.



945423-9701

Table 2-2. VDT Controller Standard Configurations

CONTROLLER ASSEMBLY PN946076 DASH NO.	TIMER ROMS PN948554			LINE COUNTER DEVICE TYPE @U41	GRAPHIC ROM OPTION NETWORK LOCATIONS		GRAPHICS OPTION JUMPER PLUG P9	CURSOR ADDRESS JUMPER PLUGS	REQUIREMENT FOR SINGLE CONTROLLER HARDWARE JUMPERS U22 PIN 10 TO 16 U33 PIN 7 TO 16 U32 PIN 4 TO 16 U30 PIN 9 TO 8	REQUIRED MEMORY NETWORKS	DESCRIPTION D/S=DUAL/SNG F/H=1920/960 50/60 HZ G=GRAPHICS
	CHARACTER DECODER ROM DASH NO. @U51	I/O DECODER ROM DASH NO. @U52	SYNC DECODER ROM DASH NO. @U42		LINE 8 PN972923-1	LINE 9 PN972923-2					
-1	-1	-2	-3	SN74162N			NONE	P6,P8,P10	NONE	U117 THRU U132 U137 THRU U152	D,F,60
-2	-1	-2	-3	SN74162N			NONE	P8,P10	YES	U137 THRU U152	S,F,60
-3	-1	-4	-5	SN94163N			NONE	P5,P7,P11	NONE	EVEN NUMBERED NETWORKS U118 THRU U132,U138 THRU U152	D,H,60
-4	-1	-4	-5	SN74163N			NONE	P7,P11	YES	EVEN NUMBERED NETWORKS U138 THRU 152	S,H,60
-5	-1	-2	-3	SN74162N	U94,U24	U85,U23	YES	P6,P8,P10	NONE	U117 THRU U132 U137 THRU U152	D,F,60,G
-6	-1	-2	-3	SN74162N	U94	U85	YES	P8,P10	YES	U137 THRU U152	S,F,60,G
-7	-1	-6	-7	SN74162N			NONE	P6,P8,P10	NONE	U117 THRU U132 U137 THRU U152	D,F,50
-8	-1	-6	-7	SN74162N			NONE	P8,P10	YES	U137 THRU U152	S,F,50
-9	-1	-8	-9	SN74163N			NONE	P5,P7,P11	NONE	EVEN NUMBERED NETWORKS U118 THRU U132,U138 THRU U152	D,H,50
-10	-1	-8	-9	SN74163N			NONE	P7,P11	YES	EVEN NUMBERED NETWORKS U138 THRU U152	S,H,50
-11	-1	-6	-7	SN74162N	U94,U24	U85,U23	YES	P6,P8,P10	NONE	U117 THRU U132 U138 THRU U152	D,F,50,G
-12	-1	-6	-7	SN74162N	U94	U85	YES	P8,P10	YES	U137 THRU U152	S,F,50,G

(A)136316



2. Insert the VDT controller circuit board into the chassis location corresponding to the desired address. Ensure that the component side of the circuit board is facing correctly and that the slots in the circuit board (inside edge) mate properly with the alignment comb on the backpanel connector.

Table 2-3. Addresses Assigned to CRU Expansion Chassis

Hexadecimal CRU Address	Hexadecimal CPU Base Address	Chassis Number
0200 - 037F	0400 - 06FE	1
0400 - 057F	0800 - 0AFE	2
0600 - 077F	0C00 - 0EFE	3
0800 - 097F	1000 - 12FE	4
0A00 - 0B7F	1400 - 16FE	5
0C00 - 0D7F	1800 - 1AFE	6
0E00 - 0F7F	1C00 - 1EFE	7

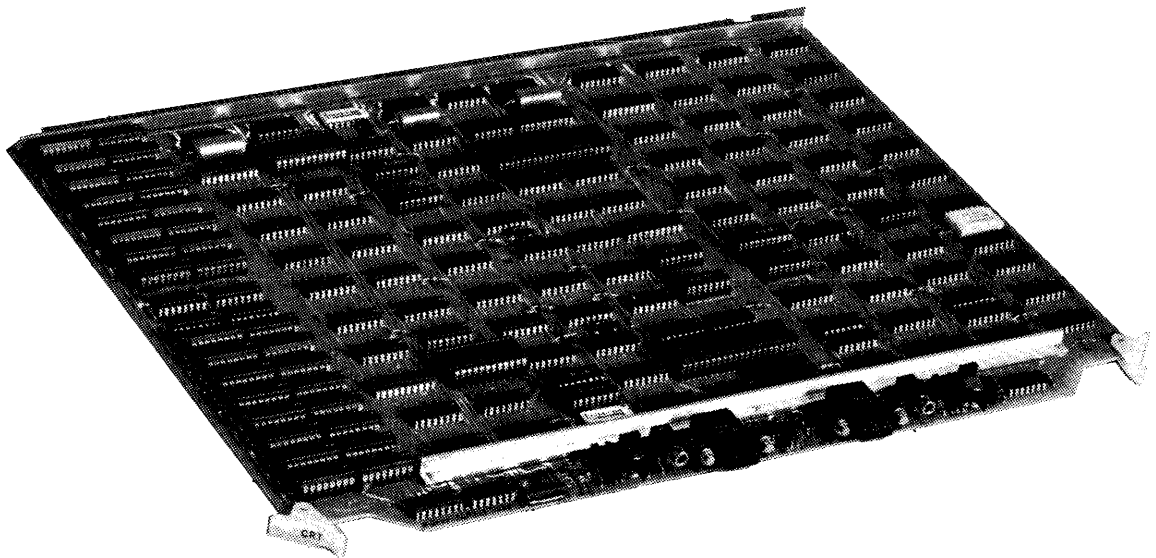

135977 (911-477-39-1)

Figure 2-6. Typical Model 911 VDT Controller Board



3. Connect plug P1 (9-pin male connector) of the interconnection cable (CRT CONTR) to the VDT controller circuit board edge connector. Ensure that the cable dresses to the rear of the computer. Engage the cable in one of the cable clamps on the computer.

NOTE

If the terminal is installed in a local location (within 5 metres (16.4 feet) of the controller), skip the remainder of this procedure.

4. Connect the connector (P2) on the controller interface cable to the extension cable connector, P1, from the remote terminal site.

2.6.3 TERMINAL INTERRUPT. An interrupt is a signal generated by the terminal keyboard to tell the computer that new input information has been entered. This interrupt enters the computer system through the VDT controller circuit board. The computer recognizes the keyboard interrupt, as well as interrupts from other CRU peripheral devices, and internal interrupts through a ranked priority system.

2.6.4 COMPUTER POWER ON. After making all connections to install the VDT controller in the proper chassis location together with its required cabling and interrupt wiring, set the POWER switch on the computer chassis to the ON position.

2.7 TERMINAL CHECKOUT

CAUTION

Perform the following check only after unplugging the power cord of the video display unit.

1. Unscrew fuseholder F1 on the rear panel of the display unit and ensure that it contains a 1-ampere fuse (0.5-ampere on 200-, 220-, and 240-volt units) in good working order. Reconnect fuse and fuseholder.

After connecting all cables and applying power to the computer, but before installing any software service routine in the computer, perform the following procedure to ensure that the terminal is properly installed:

2. Set the ON/OFF switch on the right side of the display unit to the ON position.
3. Examine Sync indicator (labeled S) on the rear of the display unit. If this indicator is lighted, skip step 4.
4. Check all cables between the display unit and the computer to ensure that they are properly connected. If Sync indicator is still not lighted, call service personnel.

NOTE

Because the software service routine is not currently installed in the computer, the display screen should be blank.

5. Depress the UPPER CASE LOCK key so that it remains in the down position; then press the letter A key on the keyboard.



6. Examine the remaining indicators (KYBD DATA) on the back of the display unit. The indicators should be lighted in the following pattern:

Pattern:	Off	On	Off	Off	Off	Off	Off	On	On	On
Indicator:	7	6	5	4	3	2	1	0	P	S

If this pattern is displayed, skip to step 8.

7. Ensure that the keyboard cable is properly connected to the display unit and repeat steps 5 and 6. If the pattern still is not displayed correctly, call service personnel.
8. The Parity indicator (P) should be lighted. If this condition is not met, call service personnel; otherwise, continue with this procedure.
9. Adjust display to provide the best possible image by using the following controls:
- Adjust the audio alarm volume control on the unit's right side to the midpoint of its range. This knob controls the volume of the "beep" tone and may be adjusted during operation to provide a louder or softer tone to suit the environment.
 - Adjust the front knob on right side of unit to control the brightness of display.

If unable to obtain a satisfactory image, call service personnel; otherwise, continue with this procedure.



SECTION III

PROGRAMMING

3.1 GENERAL

This section contains information about the terminal for use in designing a service routine to perform special functions required by specific applications of the terminal. The information is directed to personnel who are actively involved in programming the Model 990 Computer. Therefore, the section's presentation assumes that the reader is familiar with the programming information contained in the *Model 990 Computer Assembly Language Programmer's Guide* concerning both the computer and the terminal.

3.2 TERMINAL CONTROLLER INTERFACE

The interface between the computer and a VDT controller consists of 32 addressable input bits and 32 addressable output bits. Each controller contains logic for one or two video display units. Input and/or output bits are addressed by software as follows:

- Software sets the CRU base address for the desired keyboard/display unit.
- Software writes a 1 or 0 to CRU bit F_{16} to select the desired 16 bits onto the CRU interface.
- Software initiates a read or write to or from the desired CRU bit address.

Corresponding bits for the keyboard/display units have identical meanings. Software is responsible for proper selection.

3.2.1 INPUT INTERFACE. The addressable input data to the computer includes the display memory read character, a character intensity bit, keyboard character data, cursor address, and status and error signals. The input interface signals are illustrated in figures 3-1 and 3-2 and defined in table 3-1.

3.2.2 OUTPUT INTERFACE. The addressable output data from the computer includes display memory write data, test control bits, character intensity bit, write data strobe, cursor controls, interrupt enables, a word select bit and a cursor address. Figures 3-4 and 3-5 illustrate and table 3-3 defines the output interface.

3.3 SCREEN INITIALIZATION

Following a computer power-up sequence or execution of a reset instruction, the screen is blanked, and the cursor is homed. The following conditions exist:

- Monitor screen blank
- Cursor at row 0, column 0
- Keyboard interrupts inhibited
- Interrupts reset
- Test mode reset
- Cursor blanked and not blinking
- Dual intensity feature disabled.

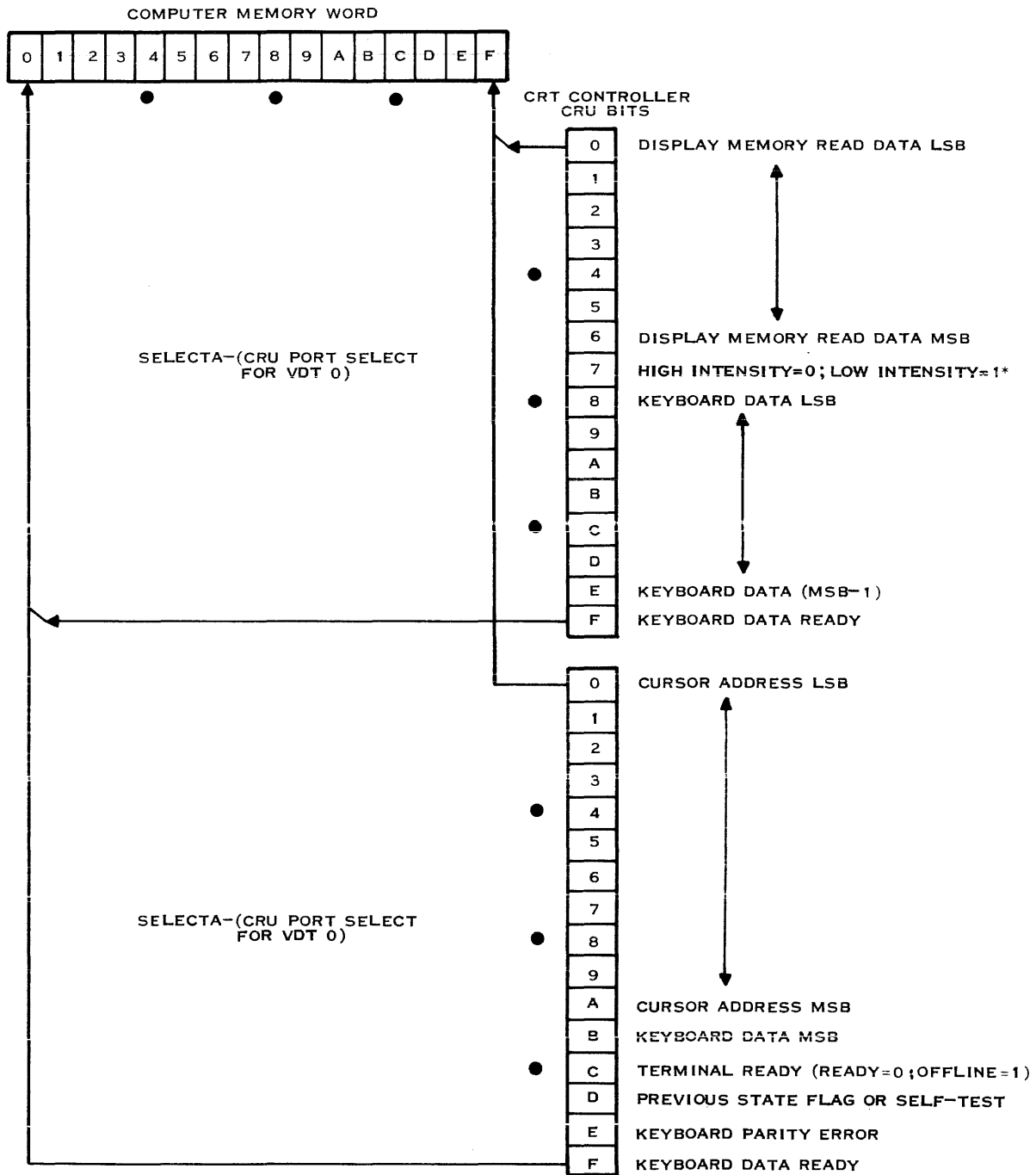

* JAPANESE KATAKANA MODELS
ALPHANUMERIC MODE=0; KATAKANA MODE=1

(A) 134317A

Figure 3-1. Computer Input Bit Assignments for Terminal 0

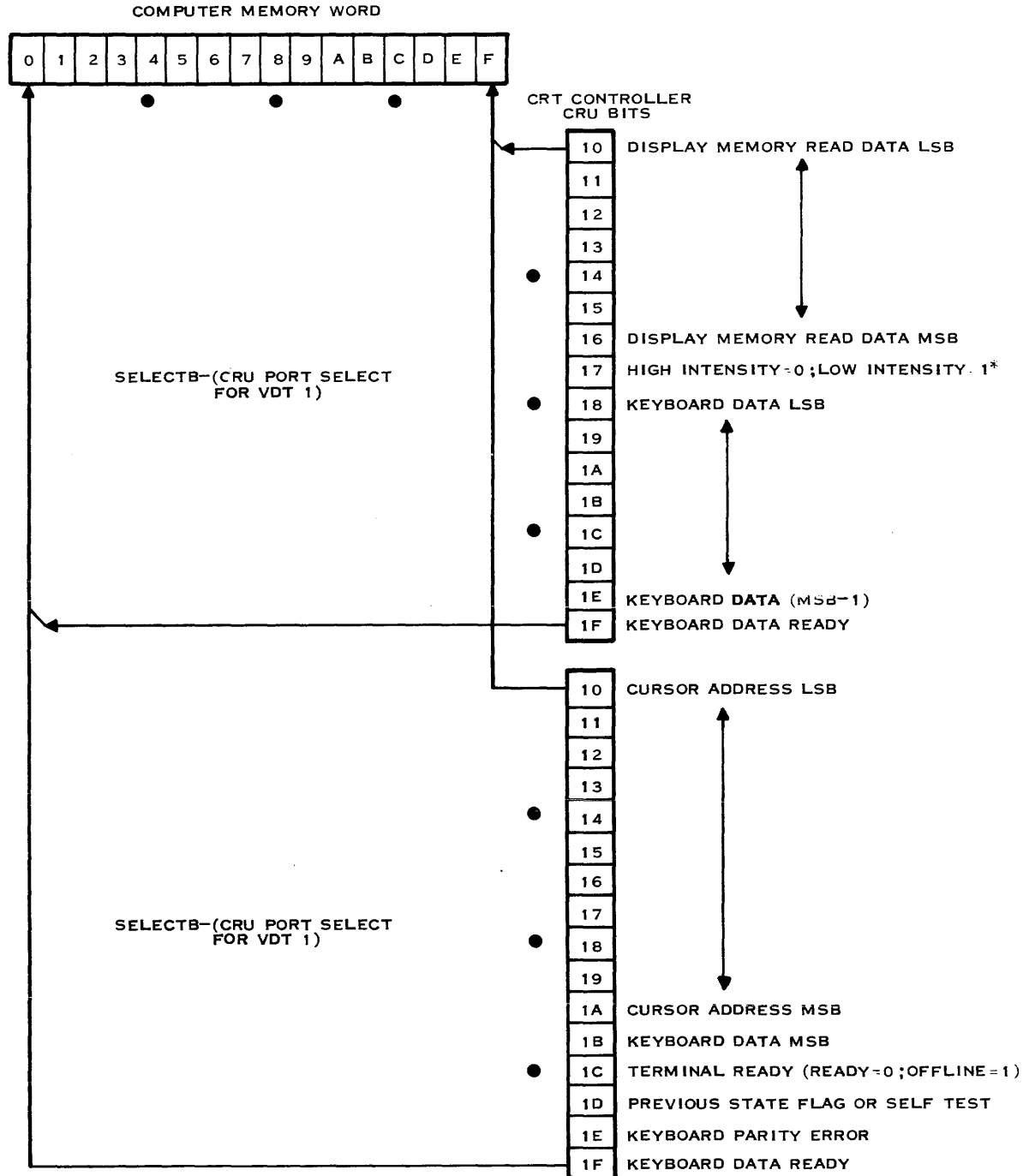

* JAPANESE KATAKANA MODEL
ALPHANUMERIC MODE=0; KATAKANA MODE=1
(A)134318A

Figure 3-2. Computer Input Bit Assignments for Terminal 1



Table 3-1. Model 911 VDT Controller Addressable Input Bits

Bit Number	Description
NOTE	
Select Word (bit F ₁₆ or 1F ₁₆) must be set to 0 for the following bit definitions.	
0 ₁₆ - 6 ₁₆ , 10 ₁₆ - 16 ₁₆	<u>Display Memory Read Data</u> – VDT memory data read from memory address defined by current cursor location. Following a power-up sequence, a write operation or cursor address change must occur before the read data is ready for access.
7 ₁₆ , 17 ₁₆	<u>Dual Intensity</u> – selects the intensity level for the VDT display. Logic 0 selects the high level of intensity; logic 1 selects the low intensity level when dual mode is an active feature. On Japanese Model 911's, all characters are displayed at high intensity; bits 7 ₁₆ and 17 ₁₆ are used to select Katakana (logic 1) or alphanumeric (logic 0).
8 ₁₆ - E ₁₆ , 18 ₁₆ - 1E ₁₆	<u>Keyboard Data</u> – least significant seven bits of keyboard character received from the VDT display unit keyboard. An 8-bit character is required to accommodate the full ASCII character set (128 characters) and additional special function keys. The keyboard control bit is in word select 1, CRU bit B ₁₆ .
F ₁₆ - 1F ₁₆	<u>Keyboard Data Ready</u> – logic 1 indicates a character has been input at the display keyboard and is available to be read by the CPU. This signal is reset to logic 0 by an output of Keyboard Acknowledge. Keyboard Data Ready may be read independent of the word-select control bit.

NOTE

The VDT controller may generate two CRU interrupts – one for each display. An interrupt signal occurs as a result of the keyboard ready signal if the keyboard interrupt and enable control associated with a display is set to logic 1.

NOTE

Select Word (Bit F₁₆ or 1F₁₆) must be set to 1 for the following bit definitions.

0 ₁₆ - A ₁₆ , 10 ₁₆ - 1A ₁₆	<u>Cursor Address</u> – indicates the position of the cursor on the screen. The cursor indicates the position of the next character to be placed on the VDT screen. The number of address bits used is determined by the total number of character positions on the screen. Ten address bits are used with 960 character displays; 11 address bits are used with 1920 character displays. An unused address bit is always read as zero. The range of addresses for the 960 and 1920 character displays is shown in figure 3-3. Note that the display memory address range exceeds the range of the screen display. Memory beyond the screen display address range is program-accessible, but is not displayed.
B ₁₆ or 1B ₁₆	<u>Keyboard Data Control Bit</u> – MSB of keyboard character.

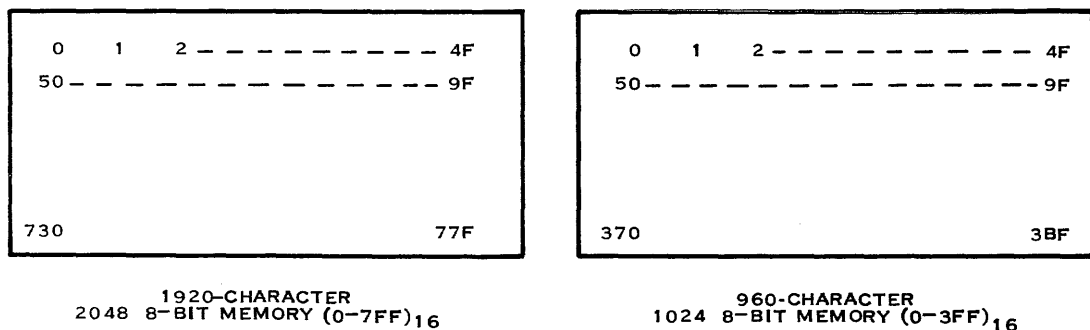

Table 3-1. Model 911 VDT Controller Addressable Input Bits (Continued)

Bit Number	Description
C ₁₆ or 1C ₁₆	<u>Terminal Ready</u> – normally indicates the status of the associated terminal. A logic 0 indicates the terminal is connected and available. A logic 1 indicates the terminal is turned off or disconnected. Also, when self-test mode is selected, terminal ready is set to logic 1.
D ₁₆ or 1D ₁₆	<p><u>Previous State Flag or Self-Test Signal</u> – indicates the state of the word-select logic before the last transfer to word 1. Logic 0 indicates word 0 was selected, and logic 1 indicates word 1 was selected. If self-test mode is selected, this signal provides one of four test inputs.</p> <p>The previous state flag permits interrupt-driven software to determine the controller state prior to a keyboard interrupt. This permits the controller to process the interrupt and restore previous conditions.</p> <p>When test mode is selected, this bit has another function. In test mode the signal read is determined by two display memory write data bits: CRU output bits 0 and 1 of word 0-VDT 0 and CRU outputs 10 and 11 of word 0-VDT 1. The signals read during test mode are video, audio “beep”, horizontal sync, and vertical sync. The signals and their characteristics are summarized in table 3-2.</p>
E ₁₆ , 1E ₁₆	<u>Keyboard Parity Error</u> – a logic 1 on this input indicates that a parity error occurred on the previous keyboard data transmission. The error indication is reset by the output signal, keyboard acknowledge. A logic 0 indicates the transmission had valid parity.
F ₁₆ , 1F ₁₆	<u>Keyboard Data Ready</u> – Logic 1 indicates a character has been input at the display keyboard and is available to be read by the CPU. This signal is reset to logic 0 by an output of keyboard acknowledge.

NOTE

The VDT controller may generate two CRU interrupts. An interrupt signal occurs as a result of the keyboard data ready signal from VDT 0 or VDT 1 if the respective keyboard interrupt enable control signal is set to logic 1.



(A)134319

Figure 3-3. Displayed Character Positions



Table 3-2. Built-In Test Input Signals

Input Signal	Test Mode	Word 0		Signal Characteristics
		CRU Bit* 0 or 10	CRU Bit* 1 or 11	
				NOTE: Program Initializes Memory
Video	1	0	0	0=All memory locations contain SPACE character (HEX 20) 1=All memory locations contain EM character (HEX 19)
Horizontal Sync	1	0	1	0=52-microsecond duration pulse 1=12-microsecond duration pulse
Vertical Sync	1	1	0	0=16.4-millisecond duration pulse at 60 Hz or 19.8-millisecond pulse at 50 Hz 1=192-microsecond duration pulse
Audio Alarm	1	1	1	0 ="BEEP" off 1 ="BEEP" on; each pulse 0.3 second duration

*CRU bits 0 and 1, word 0, selects the test signal for VDT 0.

CRU bits 10 and 11, word 0, selects the test signal for VDT 1.

3.4 KEYBOARD CODES

Striking an alphanumeric or function key on the keyboard causes a character to be transmitted to the VDT controller. The character is transmitted serially as an 8-bit byte. Seven bits are used for data and an eighth bit for control. When the control bit is OFF (logic 0) the seven data bits represent the 128-character ASCII set. When the control bit is ON (logic 1), the data represents special characters such as cursor up or function key F1. On the Japanese keyboard, the control bit selects the Katakana character set shown in figure F-9, Appendix F.

The REPEAT key on the keyboard does not produce a character. Depressing this special key in conjunction with any other key causes the character associated with that key to be generated at a rate of 10 ± 2 characters per second.

Table 3-5 shows the codes produced by the United States keyboard. Figures 3-6 through 3-9 depict key position interpretations for various modes of operation. The modes of operation are controlled by the SHIFT, CONTROL, and UPPER CASE LOCK keys. The character positions and associated codes used with the international keyboards are illustrated in the appendixes. The Japanese keyboard has mode-select switches for the alphanumeric or Katakana mode, and an indicator lamp in the switch lights shows when the Katakana mode is selected.

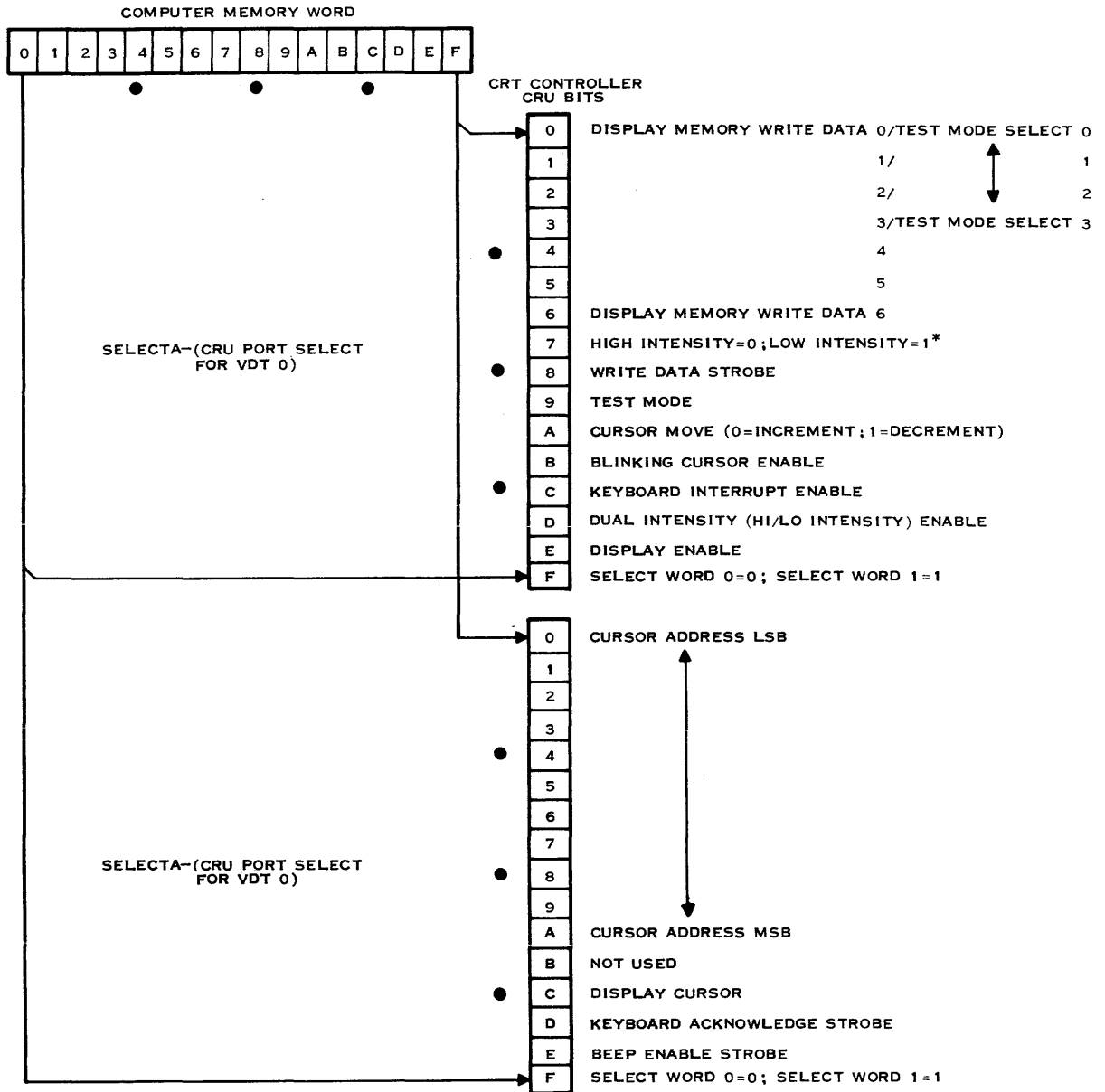

* JAPANESE KATAKANA MODEL
ALPHANUMERIC=0;KATAKANA MODE=1

(A) 134321A

Figure 3-4. Computer Output Bit Assignments for Terminal 0

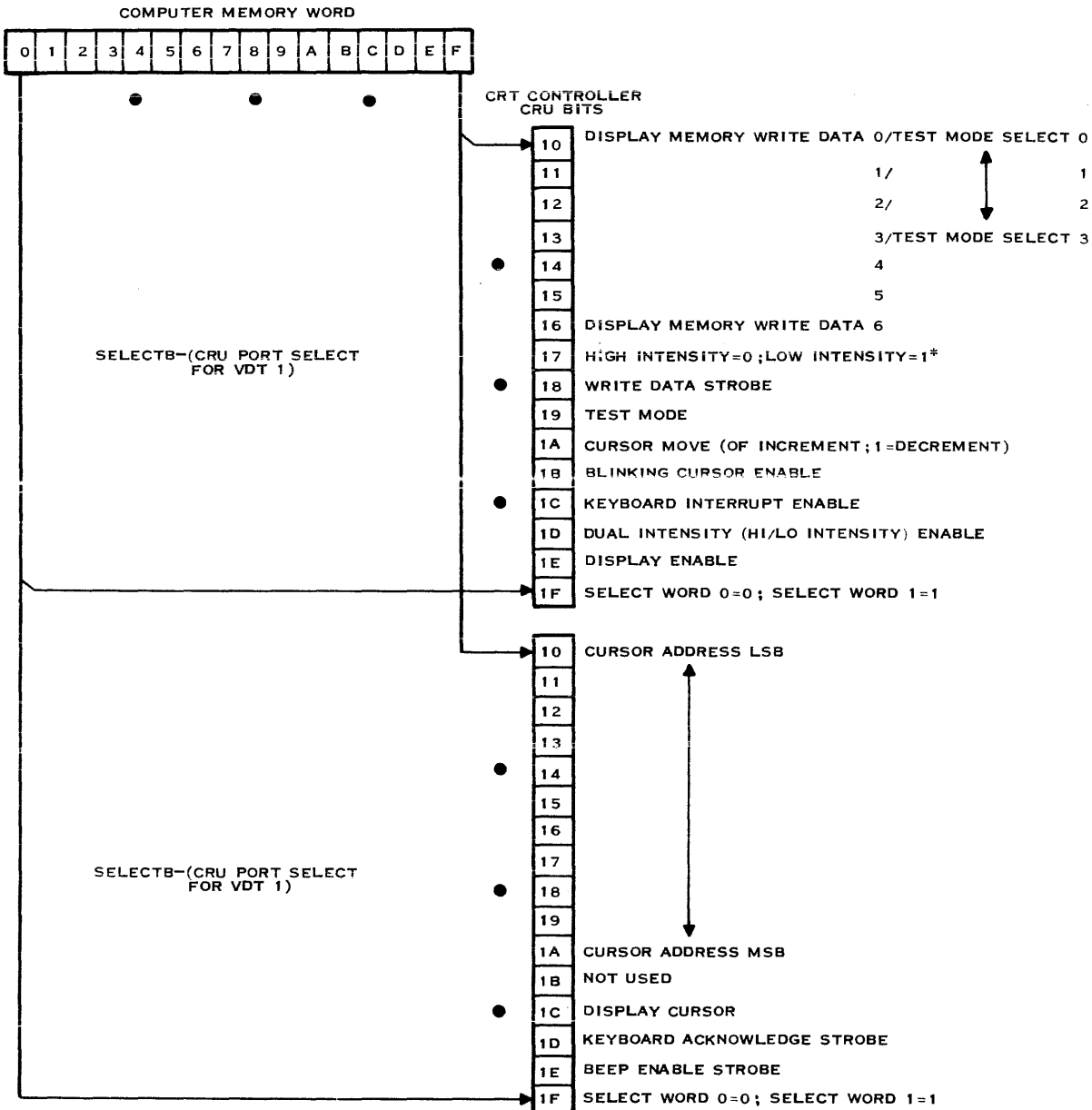

* JAPANESE KATAKANA MODEL
ALPHANUMERIC MODE=0; KATAKANA MODE=1

(A) 134320A

Figure 3-5. Computer Output Bit Assignments for Terminal 1



Table 3-3. Model 911 VDT Controller Addressable Output Bits

Bit Number

Description

NOTE

The following descriptions of the CRU bit functions assume that word select has been set to logic 0.

$0_{16} - 6_{16}, 10_{16} - 16_{16}$	<p><u>Display Memory Write Data</u> – represent an ASCII character that is to be written into the screen refresh memory. The destination of the character is determined by the contents of the cursor address register. Bit 0 is the least significant bit, and bit 6 is the most significant bit of the character. The 7-bit character and the high/low intensity bit are written into the cursor address when the write data strobe is output.</p> <p>The least significant four bits of memory write data (CRU bits 0-3 for VDT 0 and CRU bits 10-13 for VDT 1) have special significance when self-test mode is activated. Bits 0 and 1 (or bits 10 and 11) select one to four test inputs. The selected input is read as the CRU input signal previous state flag or self-test signal. Table 3-2 shows the characteristics of the test inputs. Bits 2 and 3 (or bits 12 and 13) program the input to the keyboard test transmitter. The transmitter output feeds the keyboard input circuit to simulate keyboard data. Table 3-4 relates the state of the control bits to the character generated by the transmitter.</p>
$7_{16}, 17_{16}$	<p><u>Dual Intensity</u> – selects the high or low intensity level for VDT display. Logic 0 selects high intensity display; logic 1 selects low intensity display when the dual intensity feature is active. On the Japanese model, this bit selects either the alphanumeric or the Katakana mode. A logic 0 selects alphanumeric; a logic 1 selects Katakana. All characters are displayed at high intensity.</p>
$8_{16}, 18_{16}$	<p><u>Write Data Strobe</u> – causes the contents of the display memory write data register and the dual intensity bit to be written into memory at the location specified by the cursor address register.</p> <p><u>Test Mode</u> – logic 1 selects test mode. A logic 0 output returns the control unit to the normal operation mode. Activating test mode does the following:</p> <ul style="list-style-type: none">• Turns on the test mode indicator• Tests the keyboard receiver with a serial test pattern• Selects one of four key controller signals for input on the previous state/self-test input line. <p>Keyboard data test patterns are selected by decoding write data bits 2 and 3 (or 12 and 13). Table 3-4 correlates keyboard data test patterns with select bits. As shown in table 3-2, write data bits 0 and 1 (or 10 and 11) select one of the following signals:</p> <ul style="list-style-type: none">• Video• Horizontal sync• Vertical sync• Audio alarm.



Table 3-3. Model 911 VDT Controller Addressable Output Bits (Continued)

Bit Number	Description
A ₁₆ , 1A ₁₆	<u>Cursor Move</u> — permits the cursor address register to be incremented or decremented with a single-bit transfer instruction. A logic 0 output causes the cursor address to increment. A logic 1 output decrements the cursor address.
NOTE	
Do not send write data strobe and cursor move within a single LDCR operation. The issue of separate commands assures completion of the write operation before the cursor address changes.	
The cursor address register range is between 0 ₁₆ and 3BF ₁₆ for a 960-character display and 0 ₁₆ and 77F ₁₆ for a 1920-character display.	
Note that locations 3C0 ₁₆ to 3FF ₁₆ on the 960-character display and 780 ₁₆ to 7FF ₁₆ on the 1920-character display are not displayable. These locations may be accessed by software. Software must detect when an increment or decrement of the cursor address register will move the cursor into the non-displayed region.	
B ₁₆ , 1B ₁₆	<u>Blinking Cursor Enable</u> — controls the blinking of the cursor. If the cursor is displayed, a logic 1 on this bit causes the cursor to blink at a 2-hertz rate. A logic 0 disables the blinking cursor. Blinking results from alternately displaying the cursor position character in normal and reverse video.
C ₁₆ , 1C ₁₆	<u>Keyboard Interrupt Enable</u> — controls whether a keyboard data ready signal generates a CRU interrupt. Logic 1 enables an interrupt, while logic 0 masks the data ready interrupt. Only the selected VDT keyboard logic is affected.
D ₁₆ , 1D ₁₆	<u>Dual Intensity Enable</u> — controls dual intensity on the VDT screen. Logic 0 selects high intensity for the entire screen. Logic 1 selects high intensity for all words in refresh memory with bit 7 not set, and low intensity for all words with bit 7 set. On the Japanese model, dual intensity is disabled by this bit being set to a logic 0.
E ₁₆ , 1E ₁₆	<u>Display Enable</u> — logic 1 enables data to be displayed on the VDT screen. A logic 0 blanks the screen. A master reset automatically sets display enable to logic 0.
F ₁₆ , 1F ₁₆	<u>Select Word</u> — The function of any CRU interface line is determined by the type of operation (input or output) and the select word signal level. Figures 3-1 and 3-2 and 3-4 and 3-5 show the two functions assigned to each input and output bit. The 32 input and 32 output lines on the CRU interface associated with each VDT are grouped into 16-bit words. The first set of inputs or outputs is selected when select word = 0, and the second set of interface signals is selected when select word = 1.

NOTE

The following descriptions of the CRU bit functions assume that word select has been set to logic 1.



Table 3-3. Model 911 VDT Controller Addressable Output Bits (Continued)

Bit Number	Description
$0_{16} - A_{16}, 10_{16} - 1A_{16}$	<p><u>Cursor Address</u> – provides the cursor address for the display memory. Bit 0 or 10 is the least significant bit position while Bit A_{16} or $1A_{16}$ is the most significant bit position. Bits B_{16} and $1B_{16}$ are reserved for address expansion. When the cursor address is altered, data in the new address is read by the controller into the read data register. Cursor address changes are detected when CRU bit A_{16} (or $1A_{16}$) is written. Consequently, this bit must be output regardless of the number of address bits transferred. Note that the most significant cursor bit is bit 9 for 960-character displays. Bit A_{16}, always zero, must still be output.</p> <p>Only cursor addresses between 0 and $3BF_{16}$ are displayed on the 960-character screen. Cursor addresses between 0 and $77F_{16}$ are displayed on the 1920-character screen. The nondisplayed locations may be used by the programmer or in the program. If the cursor address points to a nondisplayed location, the cursor will disappear from the screen.</p>
$B_{16}, 1B_{16}$	Not used.
$C_{16}, 1C_{16}$	<p><u>Display Cursor</u> – controls the indication of a cursor on the screen. Turning the cursor off permits it to be moved on the screen without causing annoying flashes from momentary cursor positions. A logic 1 enables a cursor indication, while a logic 0 blanks the cursor. An I/O reset instruction or a power-up reset sets display cursor to logic 0.</p>
$D_{16}, 1D_{16}$	<p><u>Keyboard Acknowledge</u> – resets the keyboard data ready flag, keyboard interrupt (if enabled), and the keyboard parity error flag. This output causes a strobe when addressed and is independent of the data value output. Data may be logic 0 or 1. An I/O reset instruction on power-up reset condition effectively forces a keyboard acknowledge strobe.</p>
$E_{16}, 1E_{16}$	<p><u>Beep Enable Strobe</u> – causes an audible “beep” at the VDT. Addressing this bit with a logic 0 or 1 data bit results in the generation of a 0.3-second tone at 2000 Hertz.</p>
$F_{16}, 1F_{16}$	<p><u>Select Word</u> – The function of any CRU interface bit is determined by the type of operation (input or output) and the select word state (logic 0 or 1). Figures 3-1 and 3-2 and 3-4 and 3-5 show the two functions assigned to each input and output bit. The 32 input and 32 output bits on the CRU interface associated with each video display terminal are grouped into 16-bit words. The first set of inputs or outputs is selected by setting select word = 0. The second set of inputs or outputs is selected by setting select word = 1.</p>



Table 3-4. Built-In Test Keyboard Simulation Data

Transmitter Control		Keyboard Data	
CRU * Select 2	CRU * Select 3	CRU Bits 8→→→F	Data in Memory MSB←→→LSB
0	0	0000 0000	0000 0000
0	1	1100 1100	0011 0011
1	0	0011 0011	1100 1100
1	1	1111 1111	1111 1111

*CRU Select 2 and 3 represent CRU bits 2 and 3 for VDT 0 or CRU bits 12 and 13 for VDT 1.

3.5 CURSOR

The cursor position appears on the screen as an illuminated character space with the symbol in that location constructed with dark dots. The presence of dark symbols in an intensified field is referred to as reverse video. Three conditions cause the cursor to disappear from the screen. First, the cursor may be removed by the interface signal Disable Video. Also, the cursor will be displayed only when the cursor address register is set to a value within the range of the displayed characters (i.e., 000-77F₁₆ for 1920-character display and 000-3BF₁₆ for 960-character display). The cursor may also be disabled by setting Display Cursor to logic 0.

The cursor indicates the position on the screen where the next entered character will be displayed. The cursor may or may not be visible depending upon CRU output bit C₁₆ or 1C₁₆ (Display Cursor). The cursor does not erase data as it moves across the screen. It also does not move automatically following entry of a new character.

Normal movement of the cursor on the display is continuous from line to line and wraps around from bottom to top of the screen. For example, if the cursor is in column 79 (rightmost column) and a right cursor movement is specified, the cursor moves to column 0 of the next line. Similarly, if the cursor is on line 11 or 23 (bottom line) and a down cursor movement is specified, software detects the instruction and moves the cursor to the same column position of line 0 (top of display).

The cursor may also be moved by software by Increment and Decrement commands or by specifying an address (location) and issuing a Cursor Move instruction.

3.6 SAMPLE ROUTINES

The following paragraphs contain coding examples of routines that perform some of the functions required to interface the computer with the display unit and keyboard. These routines may not meet unique requirements of specific display systems, and therefore, should be used only as a guide when designing custom service routines for your system. These routines assume that the CRU base address for the VDT controller is 80₁₆.



945423-9701

Table 3-5. United States Keyboard Codes

b7 b6 b5 b4 b3 b2 b1 b0	0 0	0 0	0 0	0 0	0 1	0 1	0 1	0 1	1 0	1 0	1 0
	0 0	0 1	1 0	1 1	0 0	0 1	1 0	1 1	0 0	0 1	1 0
0 0 0 0	NUL	DLE	SP	0	@	P	\	p	ERASE FIELD	HERE IS	ENTER
0 0 0 1	SOH	DC1	!	1	A	Q	a	q	ERASE INPUT	BREAK	XF1
0 0 1 0	STX	DC2	"	2	B	R	b	r	HOME	F1	
0 0 1 1	ETX	DC3	#	3	C	S	c	s	TAB	F2	
0 1 0 0	EOT	DC4	\$	4	D	T	d	t	DELETE CHAR	F3	
0 1 0 1	ENQ	NAK	%	5	E	U	e	u	SKIP	F4	
0 1 1 0	ACK	SYN	&	6	F	V	f	v	INSERT CHAR	F5	
0 1 1 1	BEL	ETB	'	7	G	W	g	w	FIELD ←	F6	
1 0 0 0	BS	CAN	(8	H	X	h	x	←	F7	
1 0 0 1	HT	EM)	9	I	Y	i	y	↑	F8	
1 0 1 0	LF	SUB	*	:	J	Z	j	z	→	PRINT	
1 0 1 1	VT	ESC	+	;	K	[k	{	↓	CMD	
1 1 0 0	FF	FS	,	<	L	\	l		FIELD ↔	(1)	
1 1 0 1	CR	GS	-	=	M]	m	}	XF2 (1)		
1 1 1 0	SO	RS	.	>	N	~	n	~	XF3 (1)		
1 1 1 1	SI	US	/	?	O	_	o		DEL	XF4 (1)	(1)

NOTES: (1) REFER TO FIGURE 3-8 FOR THE KEY POSITION REQUIRED TO GENERATE THIS CHARACTER CODE.

(1)

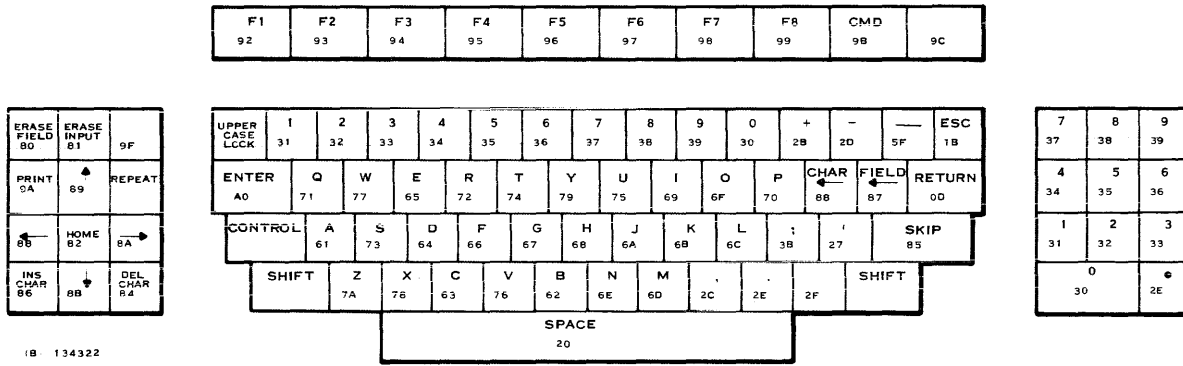

Figure 3-6. Keyboard Showing Lowercase Mode Character Positions and Hexadecimal Codes

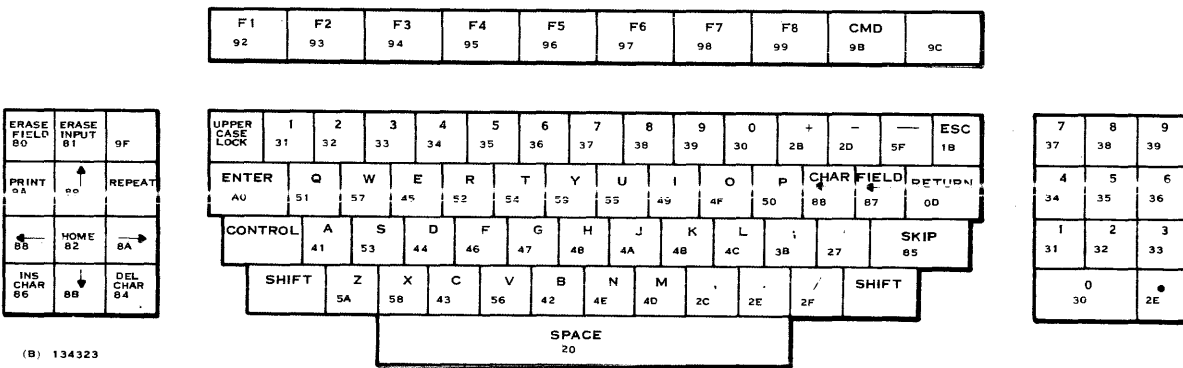

Figure 3-7. Keyboard Showing Uppercase Mode Character Positions and Hexadecimal Codes

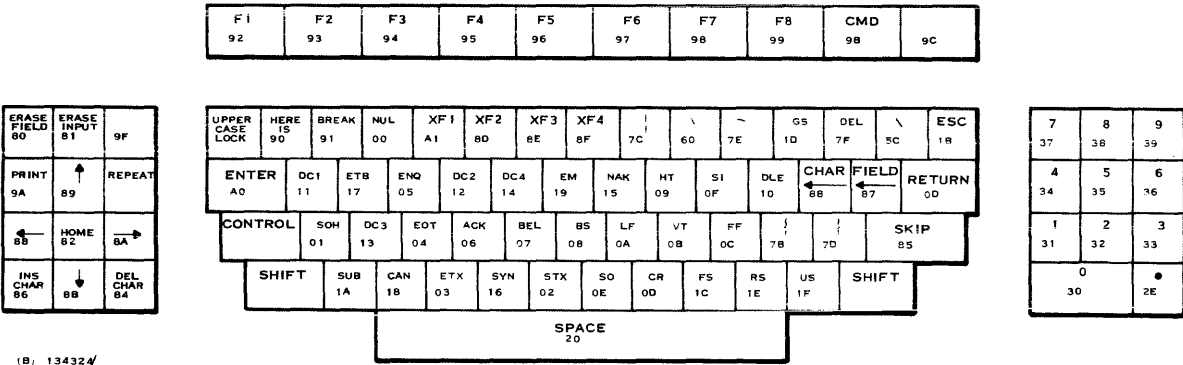
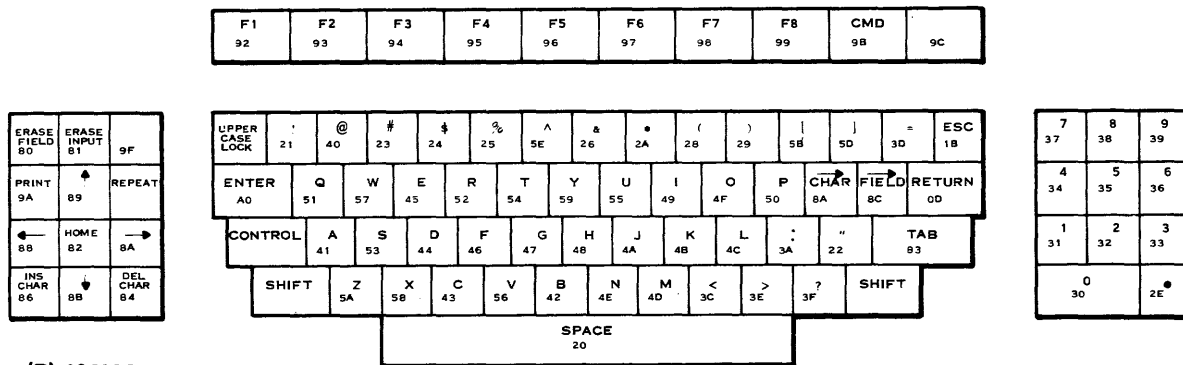

Figure 3-8. Keyboard Showing Control Character Positions and Hexadecimal Codes



(B) 134325

Figure 3-9. Keyboard Showing Shift Mode Character Positions and Hexadecimal Codes

3.6.1 POLLING ROUTINE. Because it is possible for more than one keyboard/display to share an interrupt level, it is necessary to poll a multiple-terminal system to determine which terminal has interrupted the CPU. The following code performs such a polling function.

```

R12      EQU      12           Workspace register 12
KBASE    DATA    >80,>A0,>C0,... Keyboard character base
NBASES   EQU      $.KBASE
KBDRDY   EQU      >F           Keyboard Data Ready
POLL     LI       R1,NBASES
POLLUP   MOV      @KBASE-2(1),R12  Transfer keyboard character base to
                                       workspace register 12.
TB       KBDRDY   Poll for interrupt.
JEQ      CHRPRS   Proceed to character reading sequence.
DECT     R1
JNE      POLLUP
RT
    
```

3.6.2 READ KEYBOARD. When the operator presses a key on the keyboard and the computer detects the resulting data, the I/O service routine for the terminal takes control. The I/O service routine first examines the keyboard code representing the character, and then branches to the program code that performs the desired function. Typically, the examination process necessary to determine the function of a keyboard code consists of executing a series of compare instructions and branch instructions or using a jump table. The following program code is an example of the procedure necessary to read a keyboard character and to prepare it for examination.

The following code reads keyboard data in either interrupt-driven or noninterrupt-driven modes. For interrupt-driven operation, the polling code shown in the previous paragraph must be used prior to this code.



R2	EQU	2	Workspace register 2
R9	EQU	9	Workspace register 9
R12	EQU	12	Workspace register 12
WRDSEL	EQU	>F	Select word (0=0; 1=1).
PRESEL	EQU	>D	Previous select word status
PARERR	EQU	>E	Keyboard parity error
KBACK	EQU	>D	Keyboard acknowledge
MSBDATA	EQU	>B	MSB of keyboard data
CHRPRES	SBO	WRDSEL	Select word 1.
	AI	R12, >10	Enables reading of only one byte
	CLR	R9	Clear workspace register 9.
	TB	PRESEL-8	Check previous select word state.
	JNE	SKIP1	If last state was 0
	SETO	R9	Set last state flag to 1.
SKIP1	SBZ	WRDSEL-8	Select word 0.
	STCR	R2, 7	Read bits 1-7 of character.
	SBO	WRDSEL-8	Select word 1.
	TB	MSBDATA-8	Examine most significant bit.
	JNE	NOMSB	If MSB = 0
	ORI	R2, >8000	Set MSB in data byte to 1.
NOMSB	TB	PARERR-8	Check for parity error.
	JNE	NPERR	If no error
	.		Parity error routine
	.		
NPERR	SBO	KBACK-8	Acknowledge character.
	MOVB	R9, R9	Check to see if in word 1.
	JNE	SKIP	If not in word 1
	SBZ	WRDSEL-8	Reset to proper state before interrupt.
SKIP	.		
	.		
	.		

3.6.3 ECHO CHARACTER TO SCREEN. After the character has been read from the keyboard, the program must examine the data to determine its function. If the character is to be echoed to the display screen, the following code could be used.

R2	EQU	2	Workspace register 2
R12	EQU	12	Workspace register 12
KBASE	DATA	>80	Keyboard character base
WRDSEL	EQU	>F	Select word (0 = 0; 1=1).
DTASTB	EQU	>8	Data strobe
* MOST SIGNIFICANT BYTE OF R2 CONTAINS CHARACTER TO BE ECHOED.			
	MOV	@KBASE, R12	Transfer keyboard character base to workspace register 12.
	SBZ	WRDSEL	Select word 0.
	LDCR	R2, 8	Prepare character for echo.
	SBZ	DTASTB	Strobe character to screen.



3.6.4 READ CHARACTER FROM SCREEN. When data has been assembled on the display screen, the computer may read that data and store it in memory for use by other peripheral devices or for future recall. The following program code may be used to transfer the character from the screen to the computer:

R2	EQU	2	Workspace register 2
R12	EQU	12	Workspace register 12
KBASE	DATA	>80	Keyboard character base
WRDSEL	EQU	>F	Select word (0=0; 1=1).
	MOV	@KBASE, R12	Transfer keyboard character base to workspace register 12.
	SBZ	WRDSEL	Select word 0.
	STCR	R2, 8	Read character.

3.6.5 READ CURSOR POSITION. The program may need to determine and save the exact position of the cursor before it jumps to another part of the display screen to read or write new data. The following code allows the program to store the present cursor position so that it may later restore the cursor to that position:

R2	EQU	2	Workspace register 2
R12	EQU	12	Workspace register 12
KBASE	DATA	>80	Keyboard character base
WRDSEL	EQU	>F	Select word (0=0; 1=1).
	MOV	@KBASE, R12	Transfer keyboard character base to workspace register 12.
	SBO	WRDSEL	Select word 1.
	STCR	R2, 11	Read cursor position.

3.6.6 RESTORE CURSOR POSITION. The following code may be used to return the cursor to a position on the screen that has been previously stored in workspace register 2.

R2	EQU	2	Workspace register 2
R12	EQU	12	Workspace register 12
KBASE	DATA	>80	Keyboard character base
WRDSEL	EQU	>F	Select word (0=0; 1=1).
	MOV	@KBASE, R12	Transfer keyboard character base to workspace register 12.
	SBO	WRDSEL	Select word 1.
	LDCR	R2, 11	Write cursor address.

3.6.7 MOVE CURSOR. The following code sequences move the cursor right or left, respectively, in one-position increments.

WRDSEL	EQU	>F	Select word (0=0; 1=1).
CURSOR	EQU	>A	Move cursor.
*MOVE CURSOR RIGHT ONE POSITION			
	SBZ	WRDSEL	Select word 0.
	SBZ	CURSOR	Move cursor.
*MOVE CURSOR LEFT ONE POSITION			
	SBZ	WRDSEL	Select word 0.
	SBO	CURSOR	Move cursor.

**3.6.8 CLEAR SCREEN.** The following code sequence clears the screen by filling it with blanks.

R1	EQU	1	Workspace register 1
R2	EQU	2	Workspace register 2
R12	EQU	12	Workspace register 12
KBASE	DATA	>80	Keyboard character base
WRDSEL	EQU	>F	Select word (0=0; 1=1).
SCRSIZ	EQU	1920	Screen size = 1920 characters .
VIDENB	EQU	>E	Display enable.
DTASTB	EQU	>8	Data strobe
CURSOZ	EQU	>A	Move cursor.
CLEAR	EQU	\$	
	MOV	@KBASE, R12	Transfer keyboard character base to workspace register 12.
	SBO	WRDSEL	Select word 1.
	LI	R1, >2000	
	LDCR	R1, 11	Home cursor.
	LI	R2, SCRSIZ	Load screen size into R2.
	SBZ	WRDSEL	Select word 0.
	SBZ	VIDENB	Disable video.
	LDCR	R1, 8	
CLR002	SBO	DTASTB	Strobe data to CRT.
	SBZ	CURSOR	Increment cursor address.
	DEC	R2	Decrement screen size.
	JNE	CLR002	Loop.
	SBO	VIDENB	Enable video.



3.6.9 ROLL UP SCREEN. The following code sequence moves the data displayed on the screen upward one line, shifting the top line into nondisplayable memory, and fills the bottom line with specified data.

R0	EQU	0	Workspace register 0
R1	EQU	1	Workspace register 1
R2	EQU	2	Workspace register 2
CURSOR	EQU	>A	Move cursor.
DTASTB	EQU	>8	Data strobe
WRDSEL	EQU	>F	Select word (0=0; 1=1).
MAXLYN	EQU	24	Screen size = 24 lines.
BUFF	BSS	80	Buffer filled with new bottom line
LSTCHR	DATA	1920-1	Last character position for 1920-character display.
	SBO	WRDSEL	Select word 1.
	LDCR	@ LSTCHR, 11	Set cursor address to last character position.
	SBZ	WRDSEL	Select word 0.
	LI	R0, MAXLYN	24 lines will be rolled.
LNCNT	LI	R1, 80	80 characters will be replaced.
	LI	R2, BUFF + 79	Address of last character in buffer
WRTCHR	LDCR	*R2, 8	Write last buffer character to screen.
	STCR	*R2, 8	Read last visible screen character.
	SBO	DTASTB	Strobe last buffer character to screen.
	SBO	CURSOR	Move cursor left one position.
	DEC	R2	Decrement buffer address.
	DEC	R1	Decrement column count.
	JNE	WRTCHR	Repeat 80 times.
	DEC	R0	Decrement line count.
	JNE	LNCNT	Move each line up one position.
	.		
	.		
	.		



SECTION IV

OPERATION

4.1 GENERAL

This section provides detailed information about the controls and indicators available to the terminal operator. The section also contains preventive maintenance procedures to be followed by the terminal operator.

NOTE

The Model 911 Video Display Terminal cannot be operated unless properly connected to a Model 990 family computer with the applicable software loaded.

The function of each key on the keyboard depends on the controlling input/output program resident in the computer. Therefore, before using the Model 911 Video Display Terminal, the operator must know the programmed function of each key on the keyboard to ensure that the data entered into the system is correctly interpreted by the software. In addition to the keyboard controls, controls and indicators appear on the display unit to optimize the video and audio presentation. An indicator also appears on the VDT controller board for maintenance purposes.

4.2 KEYBOARD

The standard keyboard consists of 88 keys grouped as shown in figure 4-1. The key codes can be interpreted by software to perform various functions. The standard keyboard layout illustrated in the figure is organized into five types of keys:

- Data entry keys
- Cursor control and edit keys
- Numeric keys
- Mode keys
- Repeat key.

The keyboard data keys produce an eight-bit code (see table 3-5 for United States keyboard codes, and appendixes for international keyboard codes). The mode keys determine which eight-bit code will be produced by each data key. The United States and European versions have three mode keys (SHIFT, CONTROL, and UPPER CASE LOCK) to select one of four codes for each data key. The Japanese Katakana keyboard has five mode keys to select one of six codes for various data keys. The mode keys alone do not cause an eight-bit code to be produced by the keyboard. (Refer to tables 4-1 and 4-2 for keyboard mode selection.)

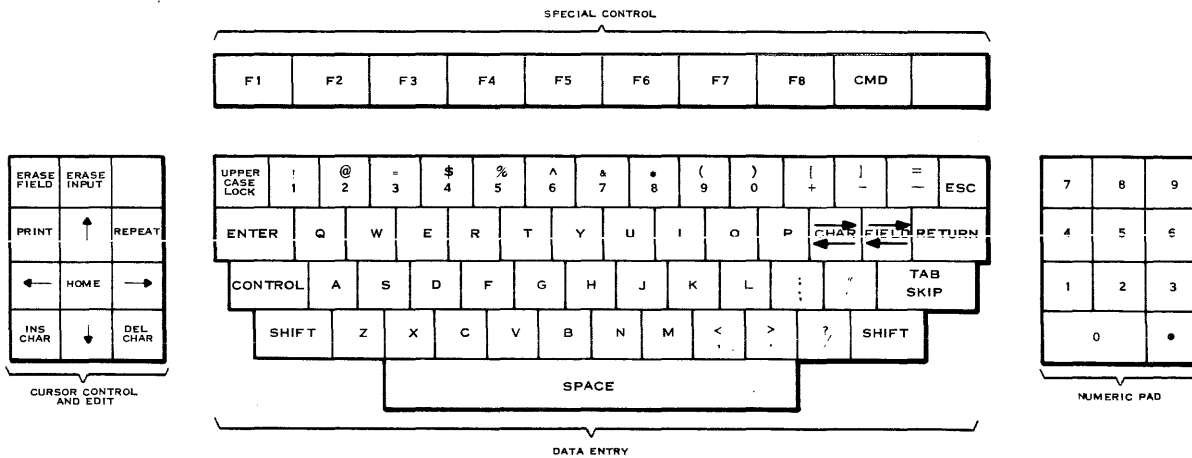

Table 4-1. United States and European Keyboard Mode Selection

SHIFT	Mode-Select Key Positions		Keyboard Mode
	CONTROL	UPPER CASE LOCK	
Up	Up	Up	Lowercase
Up	Up	Down	Uppercase
Don't Care	Down	Don't Care	Control
Down	Up	Don't Care	Shift

Table 4-2. Japanese Katakana Keyboard Mode Selection

SHIFT	CONTROL	Mode-Select Key Positions			Keyboard Mode
		UPPER CASE LOCK	Alphanumeric	Katakana	
Up	Up	Up	Down	Up	Lowercase Alpha
Up	Up	Down	Down	Up	Uppercase Alpha
Don't Care	Down	Don't Care	Don't Care	Don't Care	Control
Down	Up	Don't Care	Down	Up	Shifted Alpha
Up	Up	Don't Care	Up	Down	Unshifted KANA
Down	Up	Don't Care	Up	Down	Shifted KANA



(B)134326

Figure 4-1. United States Model 911 Keyboard

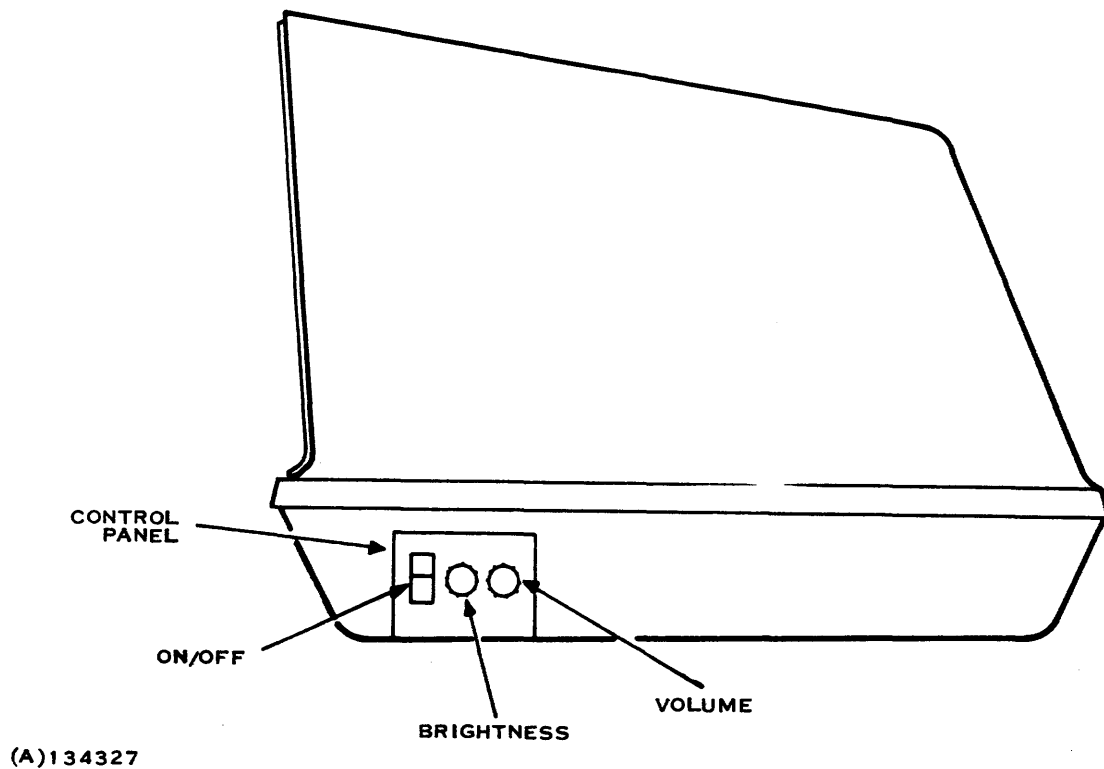

Figure 4-2. Display Unit Control Panel

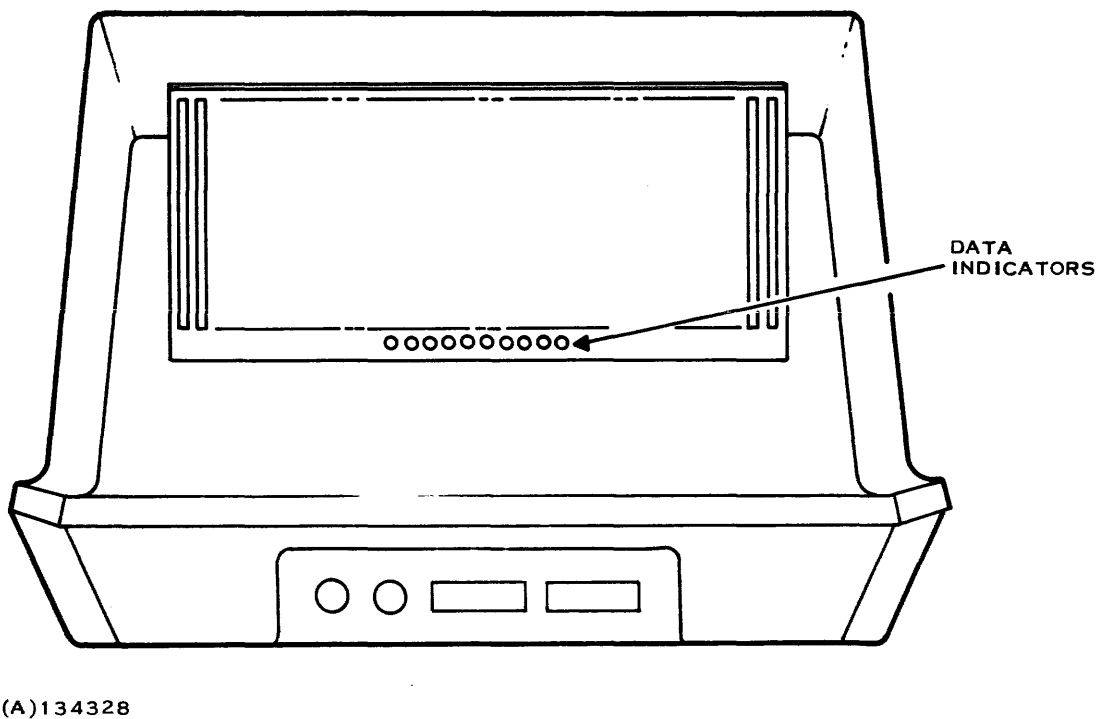

Figure 4-3. Data Indicator Locations



Keyboard interpretations for the four United States modes are shown in figures 3-6 through 3-9. (Refer to the appendixes for the European and Japanese keyboard mode interpretations.) The related input/output (I/O) software examines the code to determine the function. The repeat feature permits the operator to hold down the REPEAT key and then press any other key to generate the accompanying character (or function) at a rate of 10 ± 2 characters per second.

4.3 DISPLAY UNIT CONTROLS AND INDICATORS

The display unit has controls and indicators in two positions on the display housing: the side and rear of the cabinet. The following paragraphs describe the functions of each of these controls and indicators.

4.3.1 CONTROL PANEL. Three controls mounted on the right side of the VDT monitor housing comprise the control panel. Figure 4-2 shows the controls.

The ON/OFF switch is a rocker switch that controls ac power to the terminal.

The brightness and volume controls are rotary controls that allow the operator to vary the brightness of characters on the display and the loudness of the audio alarm, respectively.

4.3.2 DATA INDICATORS. A row of 10 light-emitting diode (LED) indicators are located in the center of the rear panel of the display unit housing as shown in figure 4-3. Figure 4-4 depicts a closer view of the indicators.

When lighted, the rightmost indicator (S) indicates that the video sync pulse is being received from the VDT controller. This indicator should always be lighted if computer interface cables are properly installed, computer and VDT power is on, and the VDT controller is inserted into the computer chassis and working properly.

When lighted the parity indicator (P) indicates that the parity bit sent to the VDT controller with the last character bits was correct. This indicator should always be on if the system is connected properly, power is on, and the display unit is transmitting data properly to the VDT controller.

The remaining indicators display the code of the character last entered on the keyboard. The indicators light to display a one bit, and remain dark to display a zero bit. Figure 4-4 illustrates a sample display for the character "A". The most significant bit (MSB) of the character code is on the left; therefore, the indicators must be read from left to right.

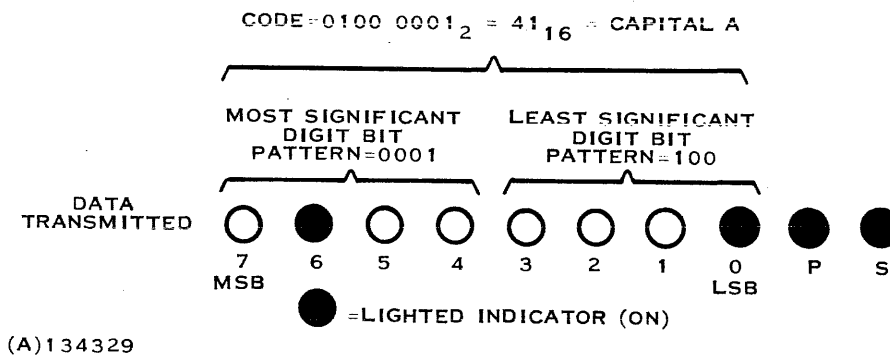

Figure 4-4. Data Indicators Sample Pattern



4.3.3 VDT CONTROLLER INDICATOR. The LED on the VDT controller lights whenever the computer performs an SBO instruction to VDT controller bit 9 or 19 to select either display section of the controller for self-test mode. The indicator may be lighted as a flag in a multicontroller system to identify an inoperative controller.

4.4 OPERATOR PREVENTIVE MAINTENANCE

The operator should wipe the screen and cabinetry of the keyboard and display unit daily with a soft, clean, lint-free, noncotton cloth. The screen and cabinetry should be wiped with a cloth dampened (not wet) with water as necessary to remove smudges, etc.



945423-9701

APPENDIX A

UNITED KINGDOM MODEL 911 VDT KEYBOARD ARRANGEMENT, HEXADECIMAL CODES, MODE CHARACTER POSITIONS, ASCII, AND SPECIAL CHARACTER SET



APPENDIX A

UNITED KINGDOM MODEL 911 VDT KEYBOARD ARRANGEMENT, HEXADECIMAL CODES, MODE CHARACTER POSITIONS, ASCII, AND SPECIAL CHARACTER SET

The standard limited-ASCII United Kingdom Model 911 VDT keyboard layout and symbolization are shown in figure A-1. Figure A-2 shows the same keyboard layout with the keys numbered. Figures A-3 through A-6 show keyboard mode character positions. Table A-1 lists the United Kingdom ASCII and special character set.

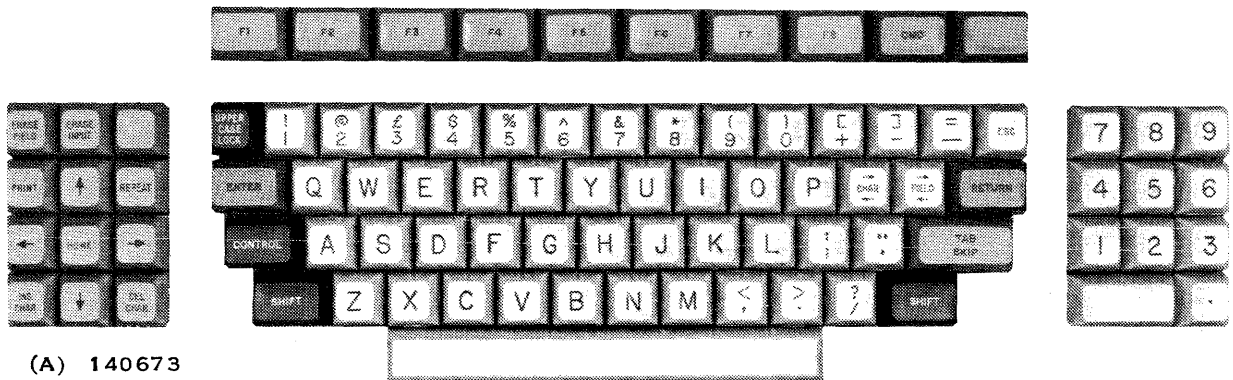

Figure A-1. United Kingdom Model 911 VDT Keyboard Arrangement

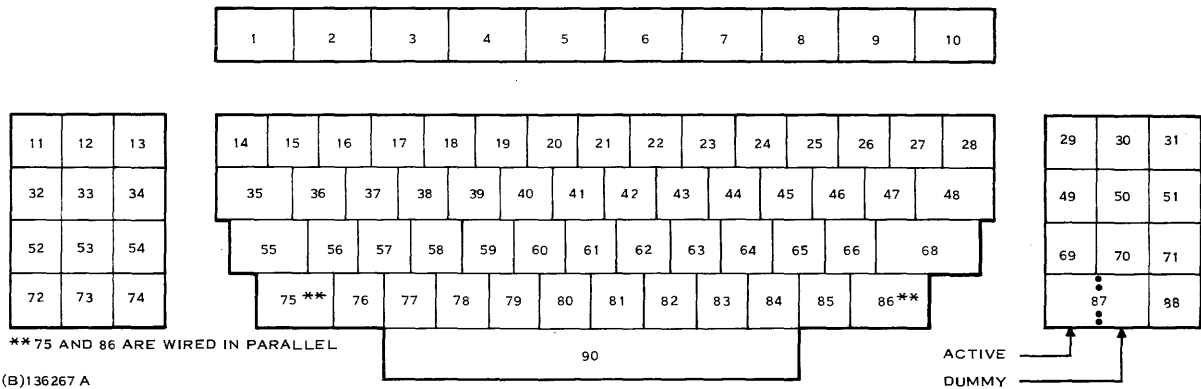

Figure A-2. United Kingdom Model 911 VDT Keyboard with Keys Numbered

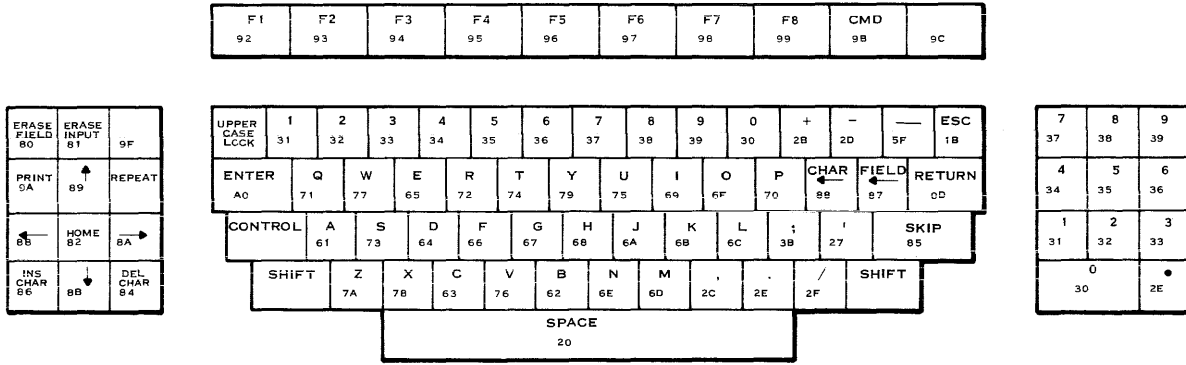

Figure A-3. United Kingdom Keyboard Showing Lowercase Mode Character Positions and Hexadecimal Codes

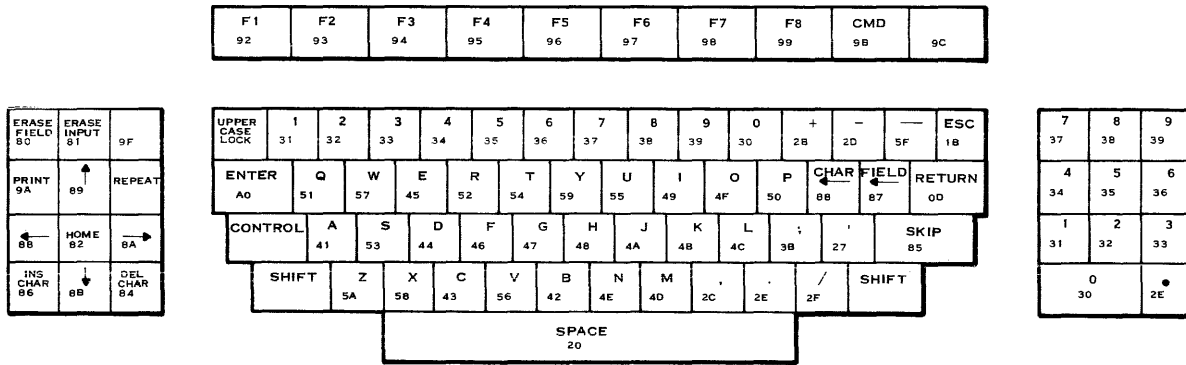
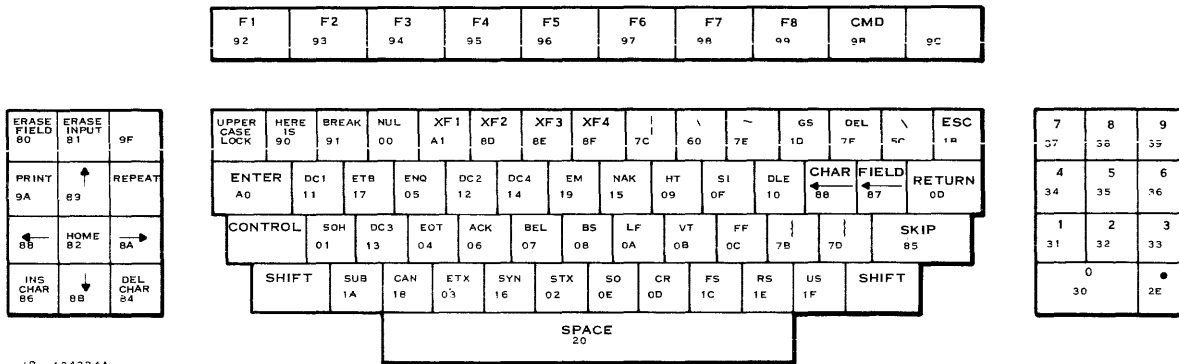

Figure A-4. United Kingdom Keyboard Showing Uppercase Mode Character Positions and Hexadecimal Codes



IB 134324A

Figure A-5. United Kingdom Keyboard Showing Control Character Positions and Hexadecimal Codes

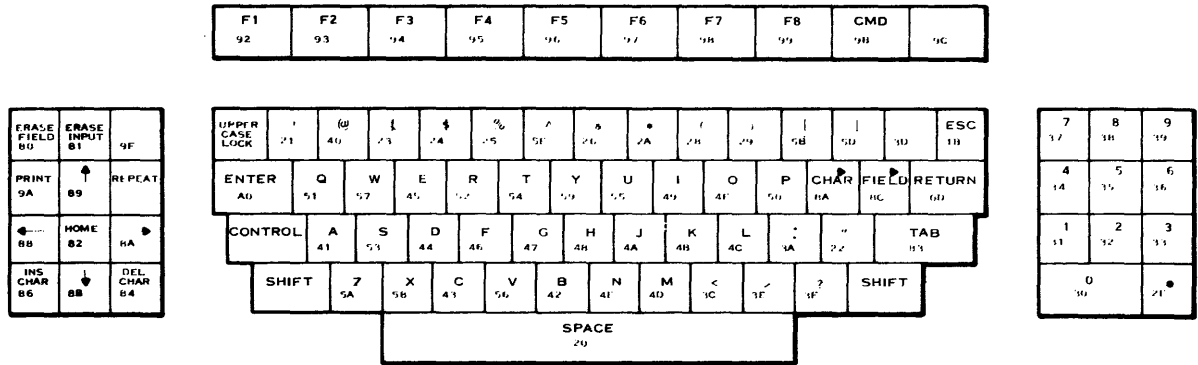

Figure A-6. United Kingdom Keyboard Showing Shift Mode Character Positions and Hexadecimal Codes



945423-9701

Table A-1. United Kingdom Model 911 VDT ASCII and Special Character Set

					SHIFT 0 0 X 1	CONTROL 0 0 1 0	UP/LOW LOCK 0 1 X X	MODE LOWER UPPER CONTROL SHIFTED										
					0	0	0	0	0	0	0	1	1	1	1	0	0	0
					0	0	0	0	1	1	1	1	1	1	0	0	0	0
					0	0	1	1	0	0	0	0	0	0	0	1	1	1
					0	1	0	1	0	1	1	0	1	1	0	0	1	0
b8	b7	b6	b5	b4	b3	b2	b1											
0	0	0	0	0	0	0	0	NUL	DLC	SP	0	@	P	\	p	ERASE FIELD	HERE IS	ENTER
0	0	0	1	0	0	0	0	SOH	DC1	!	1	A	Q	a	q	ERASE INPUT		XF1
0	0	1	0	0	0	0	0	STX	DC2	..	2	B	R	b	r	HOME	F1	
0	0	1	1	0	0	0	0	ETX	DC3	£	3	C	S	c	s	TAB	F2	
0	1	0	0	0	0	0	0	EOT	DC4	\$	4	D	T	d	t	DELETE CHAR	F3	
0	1	0	1	0	0	0	0	ENQ	NAK	%	5	E	U	e	u	SKIP	F4	
0	1	1	0	0	0	0	0	ACK	SYN	&	6	F	V	f	v	INSERT CHAR	F5	
0	1	1	1	0	0	0	0	BEL	ETB	/	7	G	W	g	w	FIELD	F6	
1	0	0	0	0	0	0	0	BS	CAN	(8	H	X	h	x	←	F7	
1	0	0	1	0	0	0	0	HT	EM)	9	I	Y	i	y	↑	F8	
1	0	1	0	0	0	0	0	LF	SUB	*	:	J	Z	j	z	→	PRINT	
1	0	1	1	0	0	0	0	VT	ESC	+	;	K	[k	}	↓	CMD	
1	1	0	0	0	0	0	0	FF	FS	,	<	L	\	l		→	FIELD	
1	1	0	1	0	0	0	0	CR	GS	-	-	M]	m	}	XF2		
1	1	1	0	0	0	0	0	SO	RS	.	>	N	^	n	~	XF3		
1	1	1	1	0	0	0	0	SI	US	/	?	O	-	o	DEL	XF4		

(A)140675

A-4

Digital Systems Division



APPENDIX B

**FRENCH MODEL 911 VDT KEYBOARD ARRANGEMENT,
HEXADECIMAL CODES, MODE CHARACTER POSITIONS,
ASCII, AND SPECIAL CHARACTER SET**



APPENDIX B

FRENCH MODEL 911 VDT KEYBOARD ARRANGEMENT, HEXADECIMAL CODES, MODE CHARACTER POSITIONS, ASCII, AND SPECIAL CHARACTER SET

The standard limited-ASCII French Model 911 VDT keyboard layout and symbolization are shown in figure B-1. Figure B-2 shows the same keyboard with the keys numbered. Figures B-3 through B-6 show keyboard mode character positions. Table B-1 lists the French ASCII and special character set.

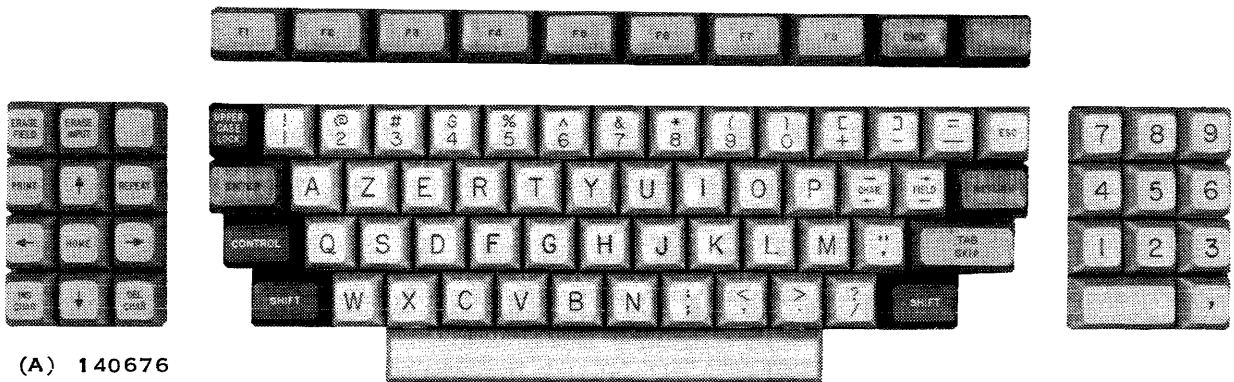

Figure B-1. French Model 911 VDT Keyboard Arrangement

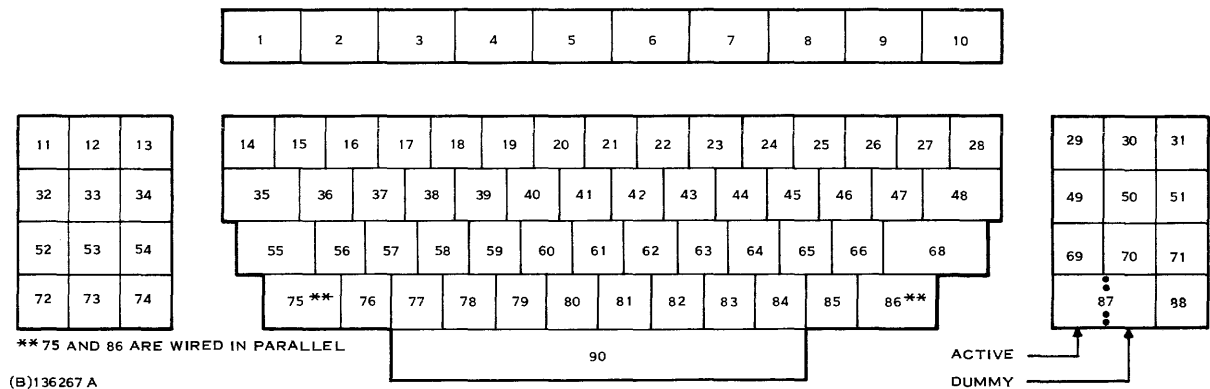

Figure B-2. French Model 911 VDT Keyboard with Keys Numbered

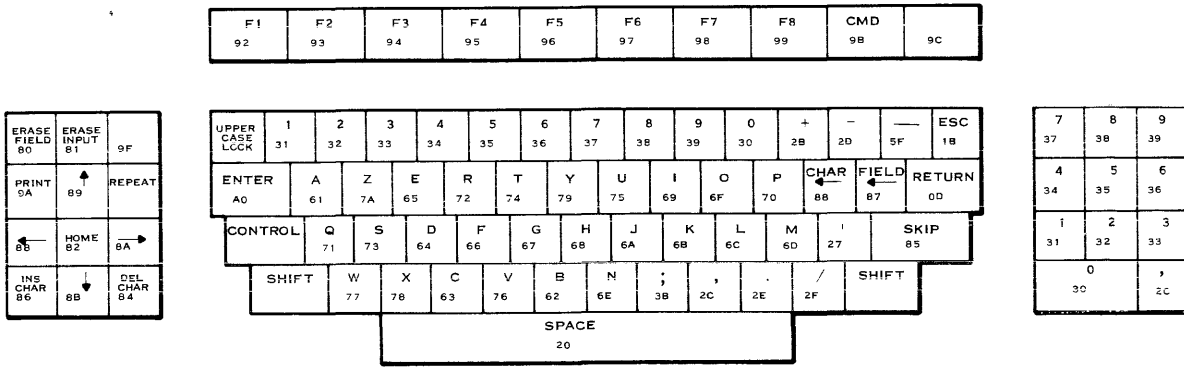

Figure B-3. French Keyboard Showing Lowercase Mode Character Positions and Hexadecimal Codes

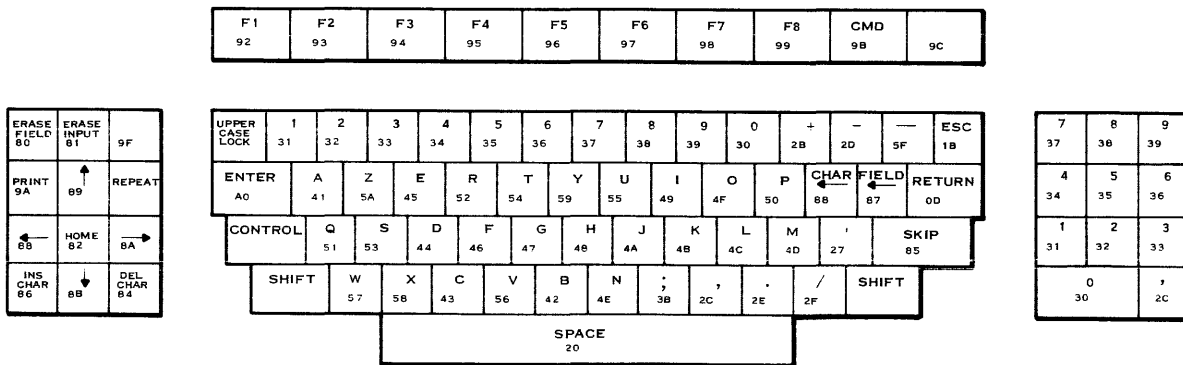
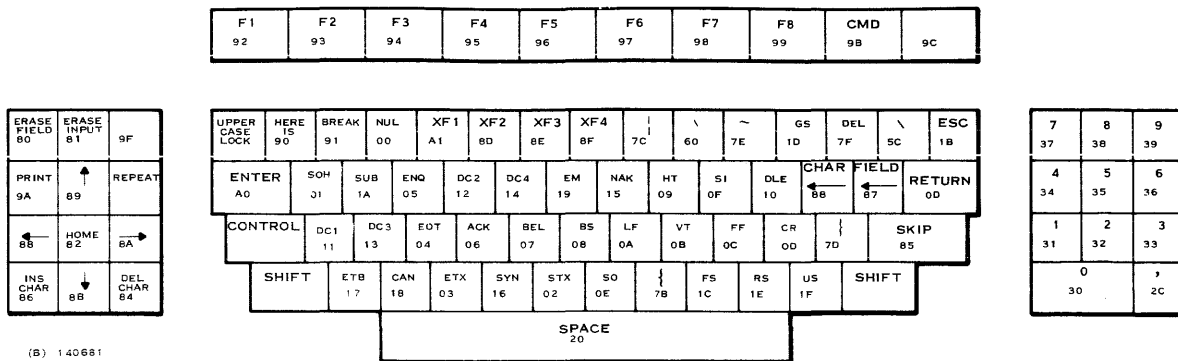

Figure B-4. French Keyboard Showing Uppercase Mode Character Positions and Hexadecimal Codes



(B) 140681

Figure B-5. French Keyboard Showing Control Character Positions and Hexadecimal Codes

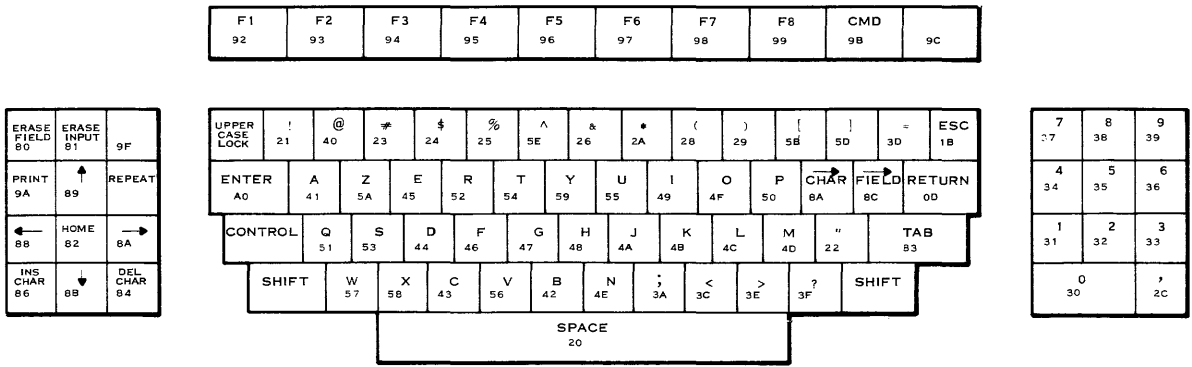

Figure B-6. French Keyboard Showing Shift Mode Character Positions and Hexadecimal Codes



Table B-1. French Model 911 VDT ASCII and Special Character Set

b8 b7 b6 b5 b4 b3 b2 b1	0	0	0	0	0	0	0	0	1	1	1	1
	0	0	1	1	0	0	1	1	0	0	1	0
0 0 0 0	NUL	DLC	SP	0	@	P	\	p	ERASE FIELD	HERE IS	ENTER	
0 0 0 1	SOH	DC1	!	1	A	Q	a	q	ERASE INPUT		XF1	
0 0 1 0	STX	DC2	..	2	B	R	b	r	HOME	F1		
0 0 1 1	ETX	DC3	#	3	C	S	c	s	TAB	F2		
0 1 0 0	EOT	DC4	\$	4	D	T	d	t	DELETE CHAR	F3		
0 1 0 1	ENQ	NAK	%	5	E	U	e	u	SKIP	F4		
0 1 1 0	ACK	SYN	&	6	F	V	f	v	INSERT CHAR	F5		
0 1 1 1	BEL	ETB	/	7	G	W	g	w	FIELD ←	F6		
1 0 0 0	BS	CAN	(8	H	X	h	x	←	F7		
1 0 0 1	HT	EM)	9	I	Y	i	y	↑	F8		
1 0 1 0	LF	SUB	*	:	J	Z	j	z	→	PRINT		
1 0 1 1	VT	ESC	+	;	K	[k	}	↓	CMD		
1 1 0 0	FF	FS	,	<	L	\	l		→ FIELD			
1 1 0 1	CR	GS	-	-	M]	m	}	XF2			
1 1 1 0	SO	RS	.	>	N	^	n	~	XF3			
1 1 1 1	SI	US	/	?	O	-	o	DEL	XF4			

(A) 140678



APPENDIX C

**GERMAN MODEL 911 VDT KEYBOARD ARRANGEMENT,
HEXADECIMAL CODES, MODE CHARACTER POSITIONS,
ASCII, AND SPECIAL CHARACTER SET**



APPENDIX C

GERMAN MODEL 911 VDT KEYBOARD ARRANGEMENT, HEXADECIMAL CODES, MODE CHARACTER POSITIONS, ASCII, AND SPECIAL CHARACTER SET

The standard limited-ASCII German Model 911 VDT keyboard layout and symbolization are shown in figure C-1. Figure C-2 shows the same keyboard with the keys numbered. Figures C-3 through C-6 show keyboard mode character positions. Table C-1 lists the German ASCII and special character set.

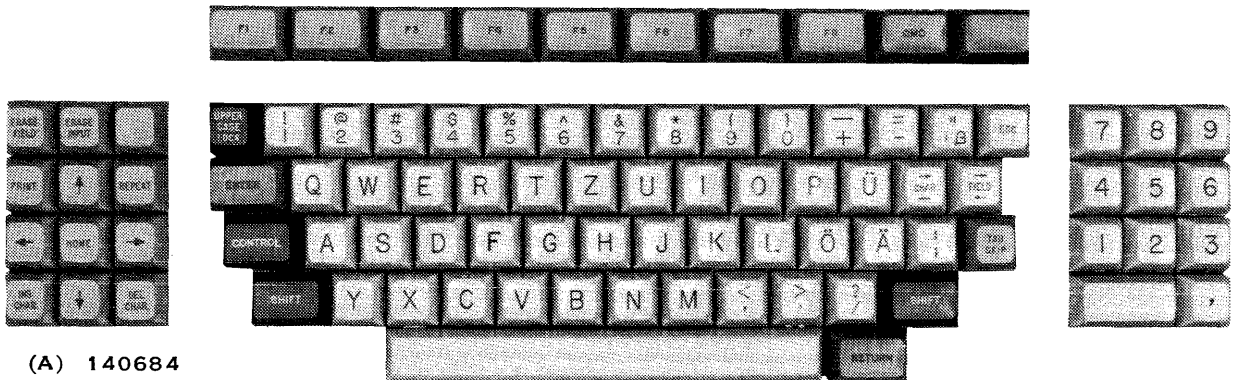

Figure C-1. German Model 911 VDT Keyboard Arrangement

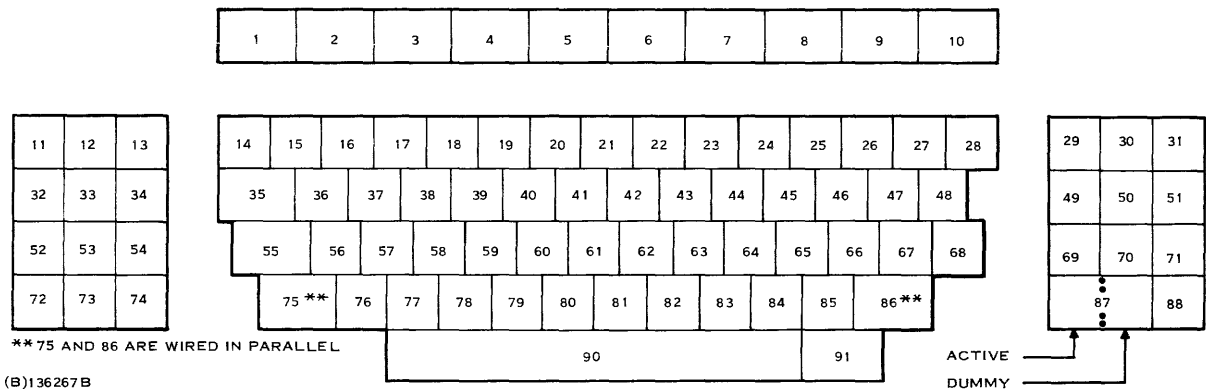
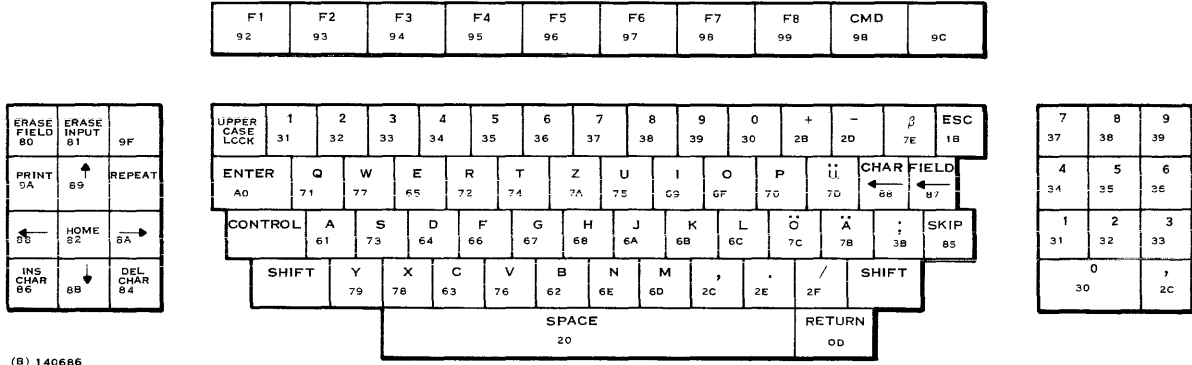
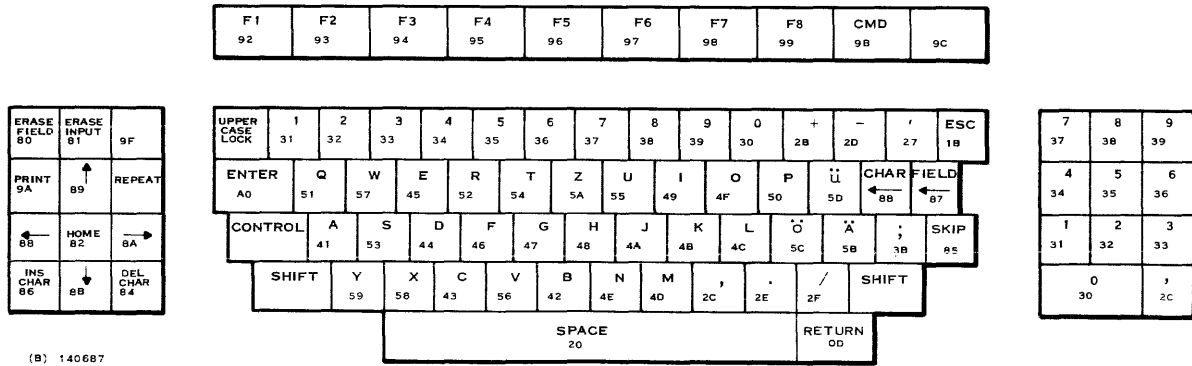

Figure C-2. German Model 911 VDT Keyboard with Keys Numbered



(B) 140686

Figure C-3. German Keyboard Showing Lowercase Mode Character Positions and Hexadecimal Codes



(B) 140687

Figure C-4. German Keyboard Showing Uppercase Mode Character Positions and Hexadecimal Codes

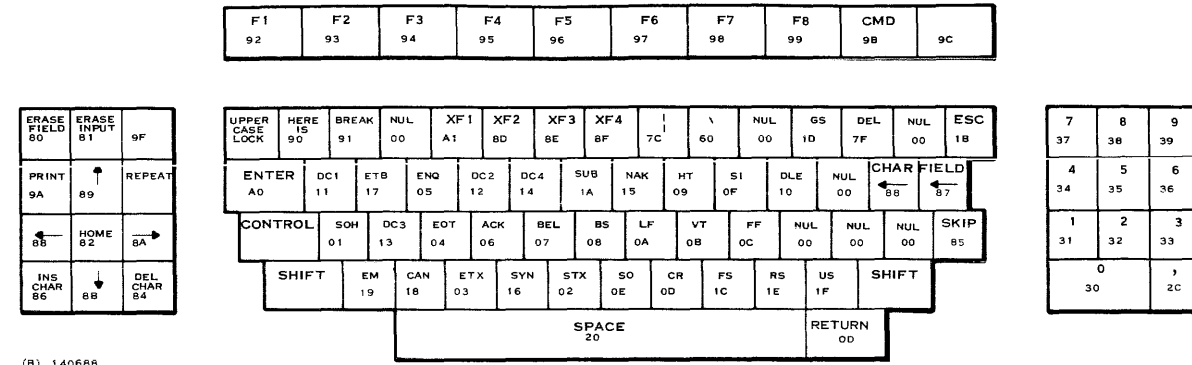

(B) 140688

Figure C-5. German Keyboard Showing Control Character Positions and Hexadecimal Codes

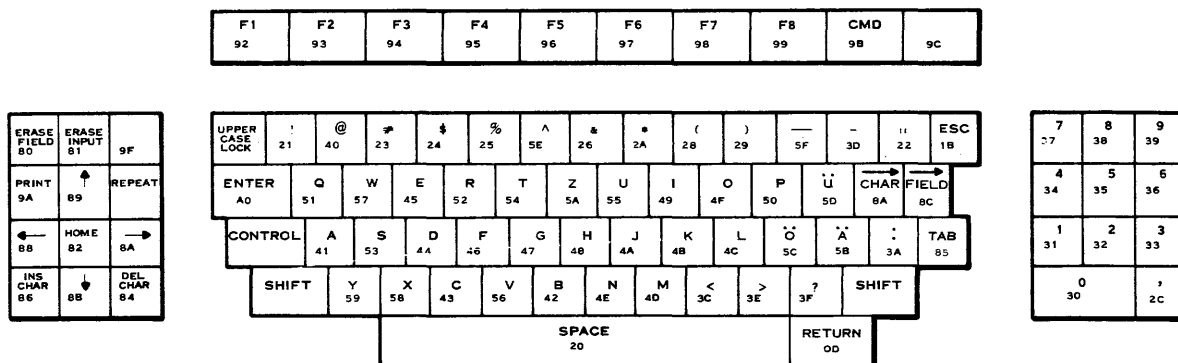

Figure C-6. German Keyboard Showing Shift Mode Character Positions and Hexadecimal Codes



Table C-1. German Model 911 VDT ASCII and Special Character Set

b8 b7 b6 b5 b4 b3 b2 b1	0 0	0 0	0 1	0 1	0 1	0 1	0 1	0 1	1 0	1 0	1 0
	0 0	0 1	1 0	1 1	0 0	0 1	1 0	1 1	0 0	0 1	1 0
0 0 0 0	NUL	DLC	SP	0	@	P	\	p	ERASE FIELD	HERE IS	ENTER
0 0 0 1	SOH	DC1	!	1	A	Q	a	q	ERASE INPUT		XF1
0 0 1 0	STX	DC2	..	2	B	R	b	r	HOME	F1	
0 0 1 1	ETX	DC3	#	3	C	S	c	s	TAB	F2	
0 1 0 0	EOT	DC4	\$	4	D	T	d	t	DELETE CHAR	F3	
0 1 0 1	ENQ	NAK	%	5	E	U	e	u	SKIP	F4	
0 1 1 0	ACK	SYN	&	6	F	V	f	v	INSERT CHAR	F5	
0 1 1 1	BEL	ETB	/	7	G	W	g	w	FIELD ←	F6	
1 0 0 0	BS	CAN	(8	H	X	h	x	←	F7	
1 0 0 1	HT	EM)	9	I	Y	i	y	↑	F8	
1 0 1 0	LF	SUB	*	:	J	Z	j	z	→	PRINT	
1 0 1 1	VT	ESC	+	:	K	Ä	k	ä	↓	CMD	
1 1 0 0	FF	FS	,	<	L	Ö	l	ö	→ FIELD		
1 1 0 1	CR	GS	-	-	M	Ü	m	ü	XF2		
1 1 1 0	SO	RS	.	>	N	^	n	β	XF3		
1 1 1 1	SI	US	/	?	O	-	o	DEL	XF4		

(A)140690



APPENDIX D

**SWEDISH/FINNISH MODEL 911 VDT KEYBOARD ARRANGEMENT,
HEXADECIMAL CODES, MODE CHARACTER POSITIONS, ASCII,
AND SPECIAL CHARACTER SET**



APPENDIX D

SWEDISH/FINNISH MODEL 911 VDT KEYBOARD ARRANGEMENT, HEXADECIMAL CODES, MODE CHARACTER POSITIONS, ASCII, AND SPECIAL CHARACTER SET

The standard limited-ASCII Swedish/Finnish Model 911 VDT keyboard layout and symbolization are shown in figure D-1. Figure D-2 shows the same keyboard with keys numbered. Figures D-3 through D-6 show keyboard mode character positions. Table D-1 lists the Swedish/Finnish ASCII and special character set.

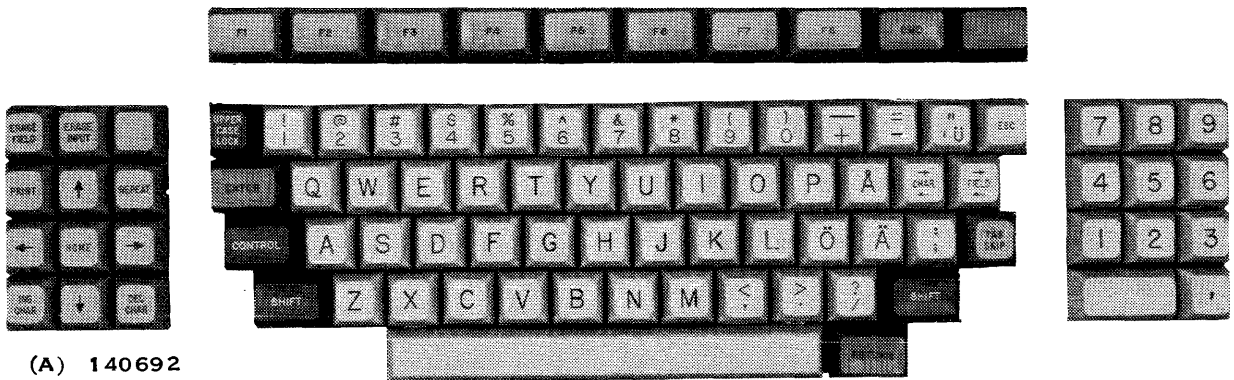

Figure D-1. Swedish/Finnish Model 911 VDT Keyboard Arrangement

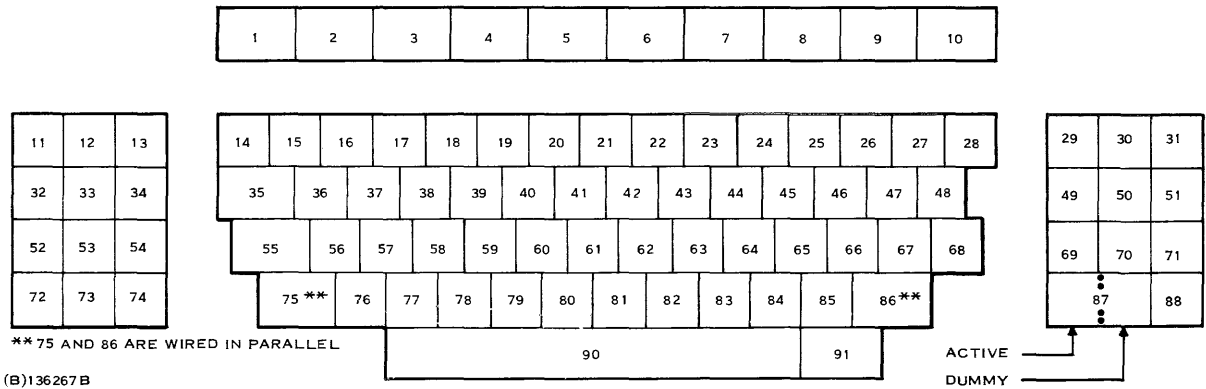

Figure D-2. Swedish/Finnish Model 911 VDT Keyboard with Keys Numbered

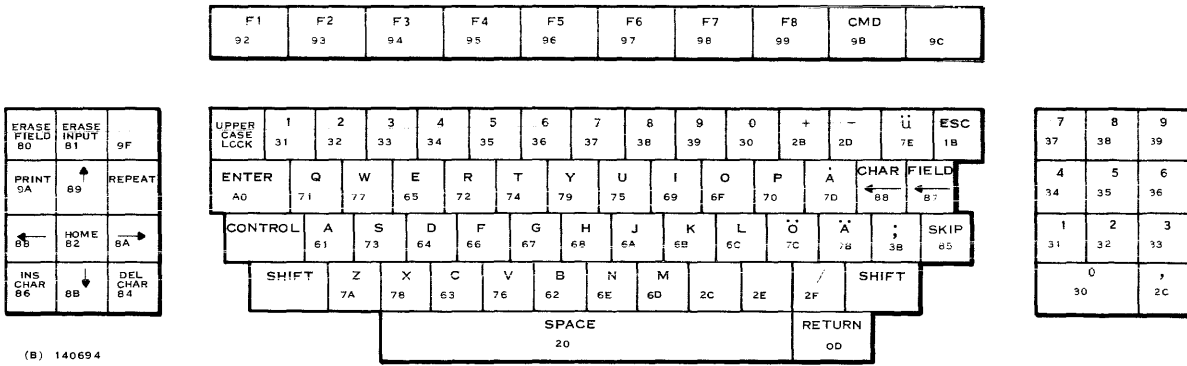

Figure D-3. Swedish/Finnish Keyboard Showing Lowercase Mode Character Positions and Hexadecimal Codes

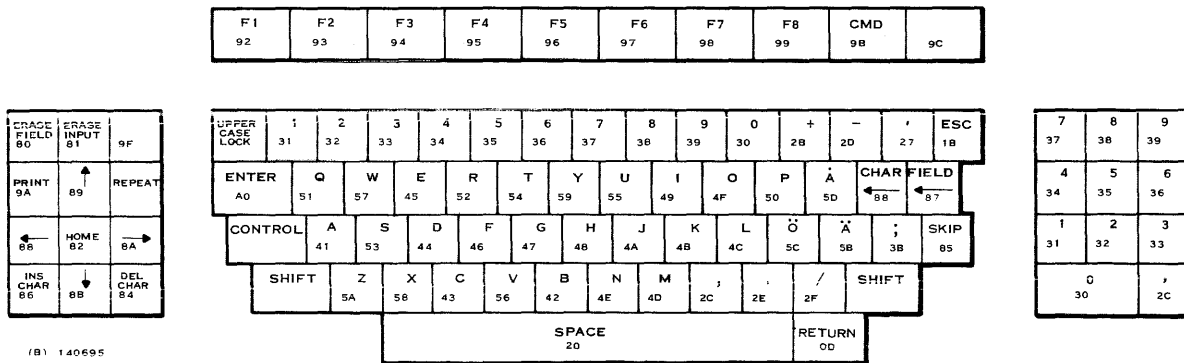

Figure D-4. Swedish/Finnish Keyboard Showing Uppercase Mode Character Positions and Hexadecimal Codes

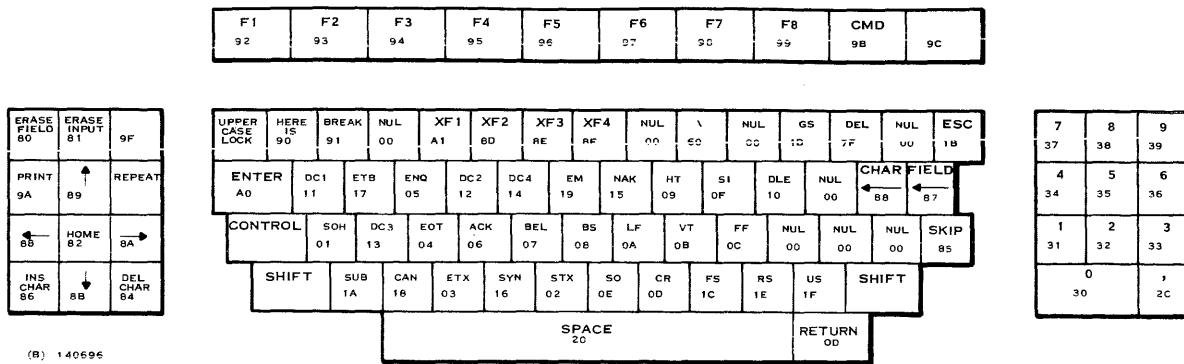

Figure D-5. Swedish/Finnish Keyboard Showing Control Character Positions and Hexadecimal Codes

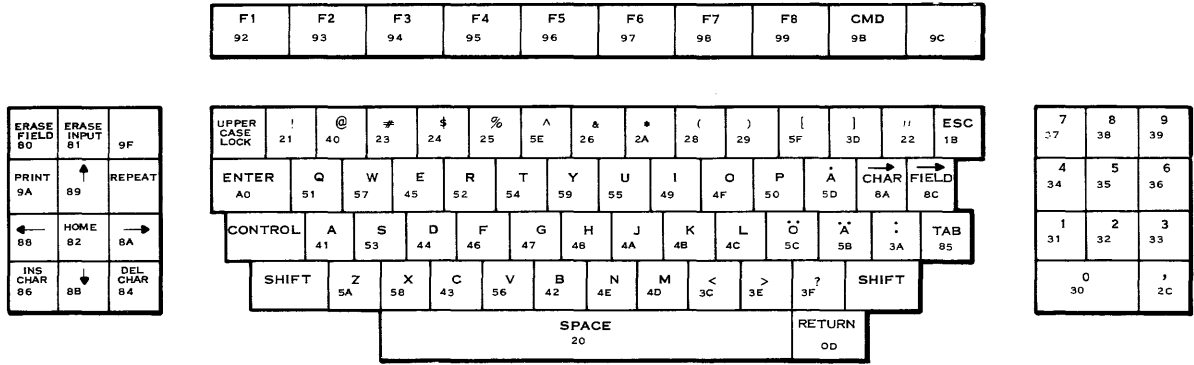

Figure D-6. Swedish/Finnish Keyboard Showing Shift Mode Character Positions and Hexadecimal Codes



945423-9701

Table D-1. Swedish/Finnish Model 911 VDT ASCII and Special Character Set

b8 b7 b6 b5 b4 b3 b2 b1	0	0	0	0	0	0	0	0	1	1	1	1
	0	0	1	1	0	0	1	1	0	0	1	0
0 0 0 0	NUL	DLC	SP	0	@	P	\	p	ERASE FIELD	HERE IS	ENTER	
0 0 0 1	SOH	DC1	!	1	A	Q	a	q	ERASE INPUT		XF1	
0 0 1 0	STX	DC2	..	2	B	R	b	r	HOME	F1		
0 0 1 1	ETX	DC3	#	3	C	S	c	s	TAB	F2		
0 1 0 0	EOT	DC4	\$	4	D	T	d	t	DELETE CHAR	F3		
0 1 0 1	ENQ	NAK	%	5	E	U	e	u	SKIP	F4		
0 1 1 0	ACK	SYN	&	6	F	V	f	v	INSERT CHAR	F5		
0 1 1 1	BEL	ETB	/	7	G	W	g	w	FIELD ←	F6		
1 0 0 0	BS	CAN	(8	H	X	h	x	←	F7		
1 0 0 1	HT	EM)	9	I	Y	i	y	↑	F8		
1 0 1 0	LF	SUB	*	:	J	Z	j	z	→	PRINT		
1 0 1 1	VT	ESC	+	;	K	Ä	k	ä	↓	CMD		
1 1 0 0	FF	FS	,	<	L	Ö	l	ö	→ FIELD			
1 1 0 1	CR	GS	-	-	M	Å	m	å	XF2			
1 1 1 0	SO	RS	.	>	N	^	n	ü	XF3			
1 1 1 1	SI	US	/	?	O	-	o	DEL	XF4			

(A)140698

D-4

Digital Systems Division



APPENDIX E

**NORWEGIAN/DANISH KEYBOARD ARRANGEMENT,
HEXADECIMAL CODES, MODE CHARACTER POSITIONS,
ASCII, AND SPECIAL CHARACTER SET**



APPENDIX E

NORWEGIAN/DANISH KEYBOARD ARRANGEMENT, HEXADECIMAL CODES, MODE CHARACTER POSITIONS, ASCII, AND SPECIAL CHARACTER SET

The standard limited-ASCII Norwegian/Danish Model 911 VDT keyboard layout and symbolization are shown in figure E-1. Figure E-2 shows the same keyboard with keys numbered. Figures E-3 through E-6 show keyboard mode character positions. Table E-1 lists the Norwegian/Danish ASCII and special character set.

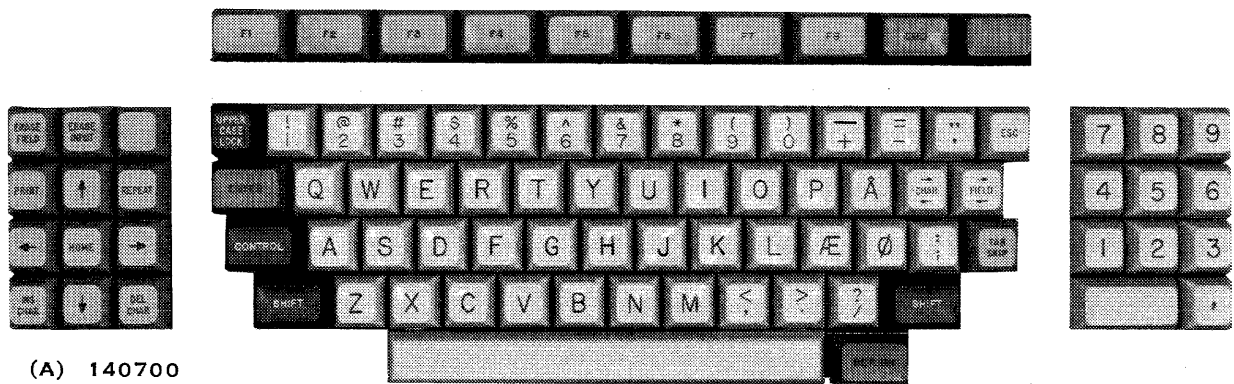

Figure E-1. Norwegian/Danish Model 911 VDT Keyboard Arrangement

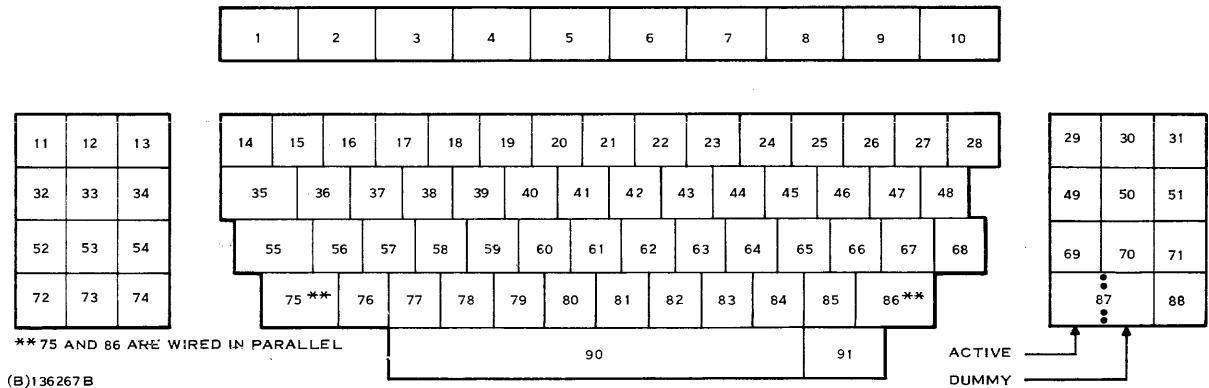
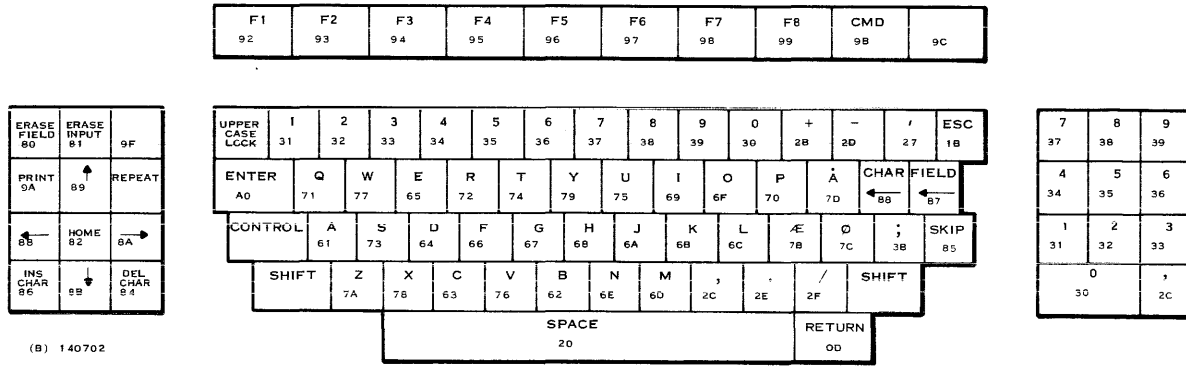
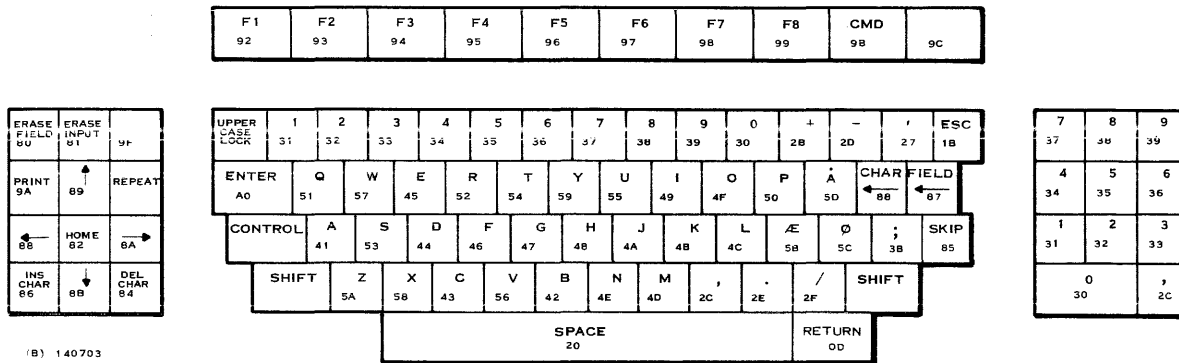

Figure E-2. Norwegian/Danish Model 911 VDT Keyboard with
Keys Numbered



(B) 140702

Figure E-3. Norwegian/Danish Keyboard Showing Lowercase Mode Character Positions and Hexadecimal Codes



(B) 140703

Figure E-4. Norwegian/Danish Keyboard Showing Uppercase Mode Character Positions and Hexadecimal Codes

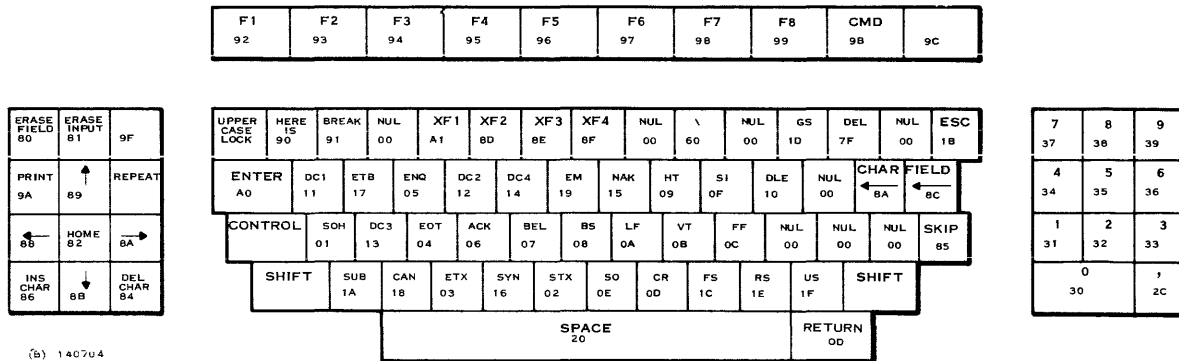

(B) 140704

Figure E-5. Norwegian/Danish Keyboard Showing Control Character Positions and Hexadecimal Codes

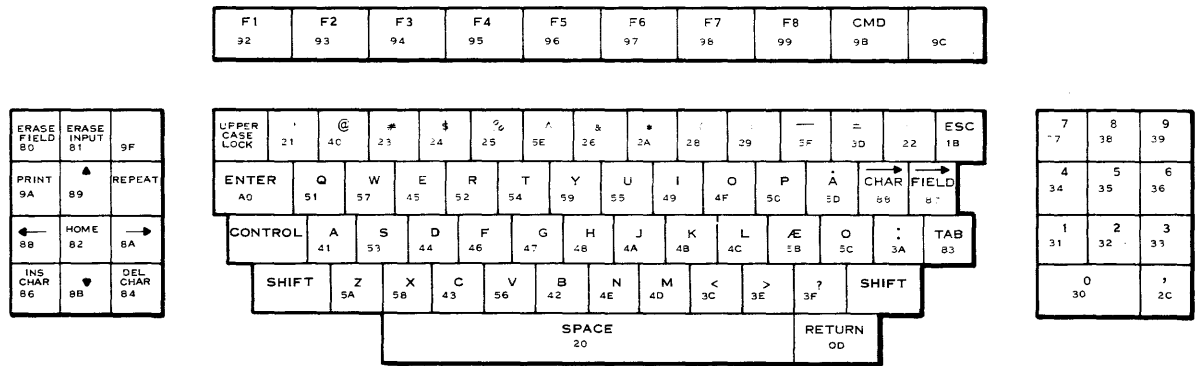

(B) 140705

Figure E-6. Norwegian/Danish Keyboard Showing Shift Mode Character Positions and Hexadecimal Codes



Table E-1. Norwegian/Danish Model 911 VDT ASCII and Special Character Set

b8 b7 b6 b5 b4 b3 b2 b1	0	0	0	0	0	0	0	0	1	1	1
	0	0	1	1	0	1	1	1	0	0	1
0 0 0 0	NUL	DLC	SP	0	@	P	\	p	ERASE FIELD	HERE IS	ENTER
0 0 0 1	SOH	DC1	!	1	A	Q	a	q	ERASE INPUT		XF1
0 0 1 0	STX	DC2	..	2	B	R	b	r	HOME	F1	
0 0 1 1	ETX	DC3	#	3	C	S	c	s	TAB	F2	
0 1 0 0	EOT	DC4	\$	4	D	T	d	t	DELETE CHAR	F3	
0 1 0 1	ENQ	NAK	%	5	E	U	e	u	SKIP	F4	
0 1 1 0	ACK	SYN	&	6	F	V	f	v	INSERT CHAR	F5	
0 1 1 1	BEL	ETB	/	7	G	W	g	w	FIELD	F6	
1 0 0 0	BS	CAN	(8	H	X	h	x	←	F7	
1 0 0 1	HT	EM)	9	I	Y	i	y	↑	F8	
1 0 1 0	LF	SUB	*	:	J	Z	j	z	→	PRINT	
1 0 1 1	VT	ESC	+	;	K	Æ	k	æ	↓	CMD	
1 1 0 0	FF	FS	,	<	L	ø	l	ø	→	FIELD	
1 1 0 1	CR	GS	-	=	M	Å	m	å	XF2		
1 1 1 0	SO	RS	.	>	N	^	n	~	XF3		
1 1 1 1	SI	US	/	?	O	-	o	DEL	XF4		

(A)140706



APPENDIX F

**JAPANESE KATAKANA KEYBOARD ARRANGEMENT,
HEXADECIMAL CODES, MODE CHARACTER POSITIONS,
MODIFIED ASCII (JIS-8), SPECIAL CHARACTER SET,
AND ADDITIONAL EIGHT-BIT DISPLAYED CHARACTER SET**



APPENDIX F

JAPANESE KATAKANA KEYBOARD ARRANGEMENT, HEXADECIMAL CODES, MODE CHARACTER POSITIONS, MODIFIED ASCII (JIS-8), SPECIAL CHARACTER SET, AND ADDITIONAL EIGHT-BIT DISPLAYED CHARACTER SET

The standard limited-ASCII Japanese Katakana Model 911 VDT keyboard layout and symbolization are shown in figure F-1. Figure F-2 shows the same keyboard with keys numbered. Figures F-3 through F-8 show keyboard mode character positions. Table F-1 lists the Japanese Katakana modified ASCII (JIS-8) and special character set. The additional 128 eight-bit characters included in the displayed character set are illustrated in figure F-9.

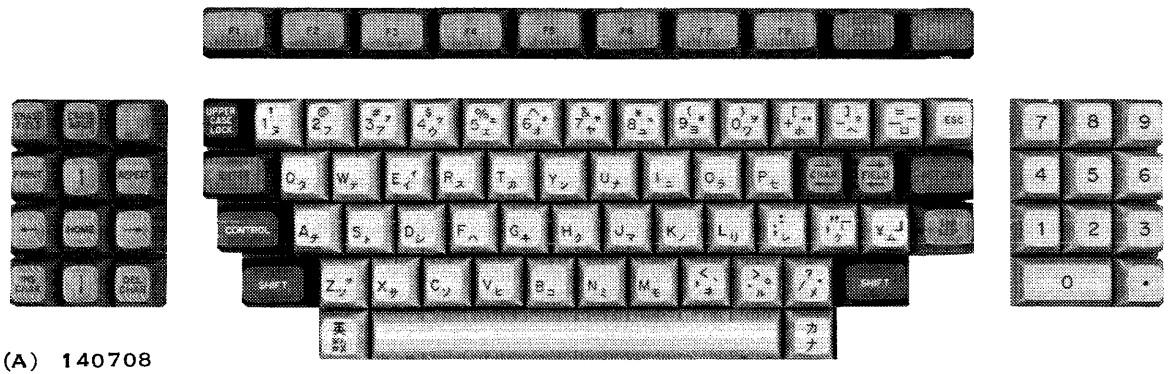

Figure F-1. Japanese Katakana Model 911 VDT Keyboard Arrangement

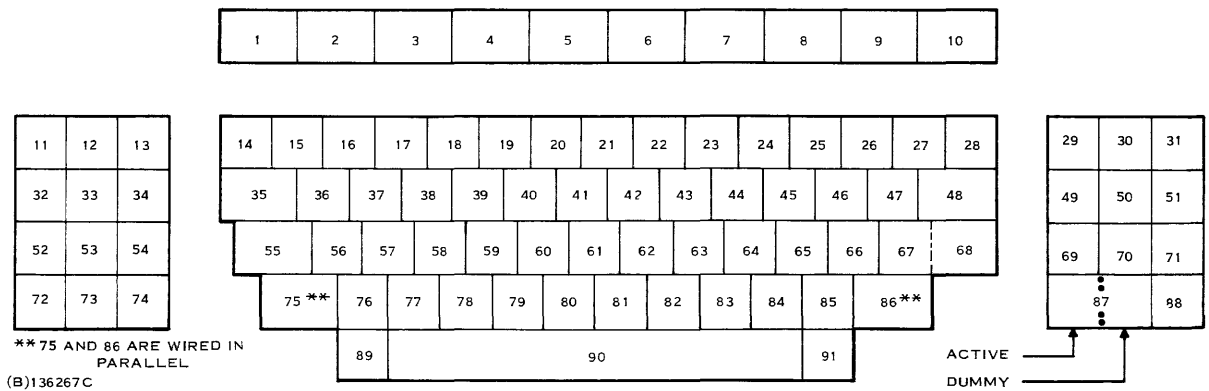

Figure F-2. Japanese Model 911 VDT Keyboard with Keys Numbered

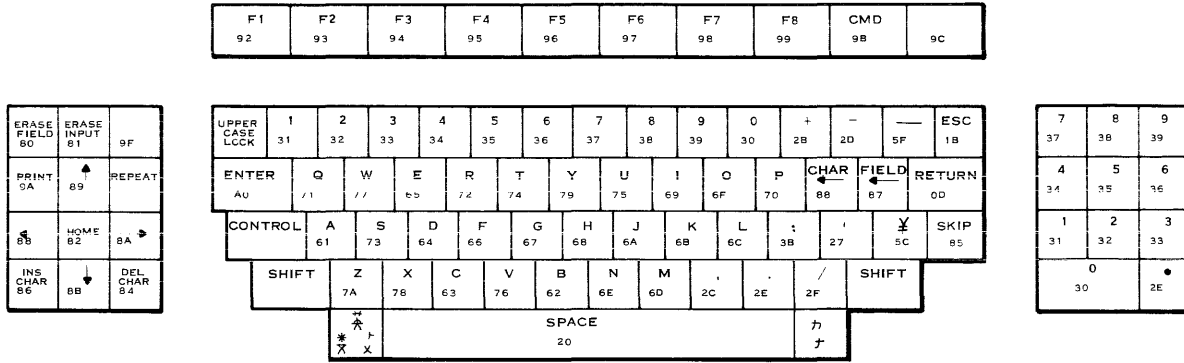

Figure F-3. Japanese Keyboard Showing Lowercase Alpha Mode Character Positions and Hexadecimal Codes

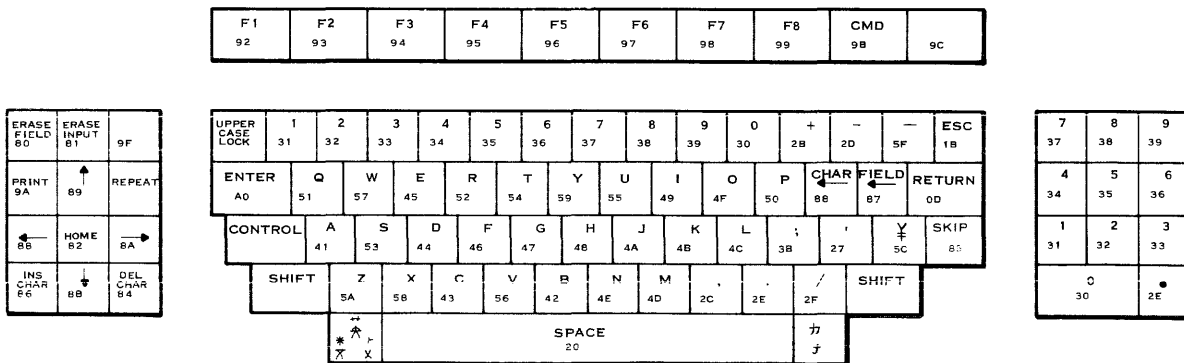
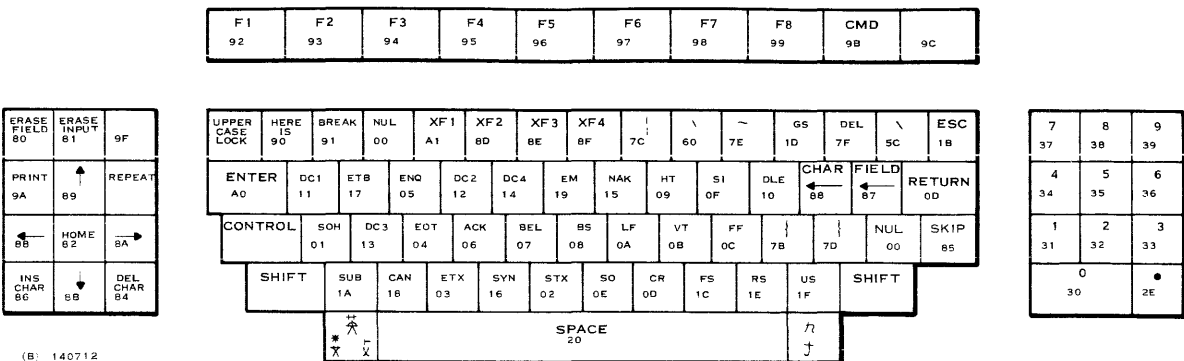
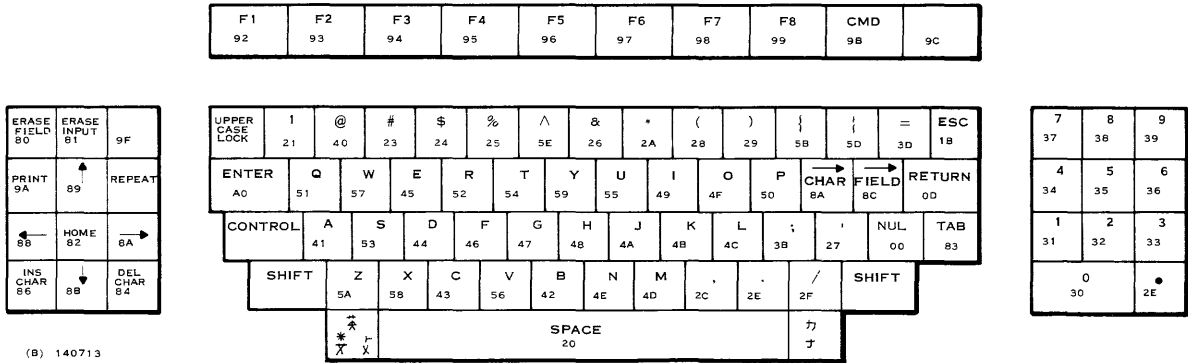

Figure F-4. Japanese Keyboard Showing Uppercase Lock Alpha Mode Character Positions and Hexadecimal Codes



(B) 140712

Figure F-5. Japanese Keyboard Showing Control Character Positions and Hexadecimal Codes



(B) 140713

Figure F-6. Japanese Keyboard Showing Shift Mode Alpha Character Positions and Hexadecimal Codes

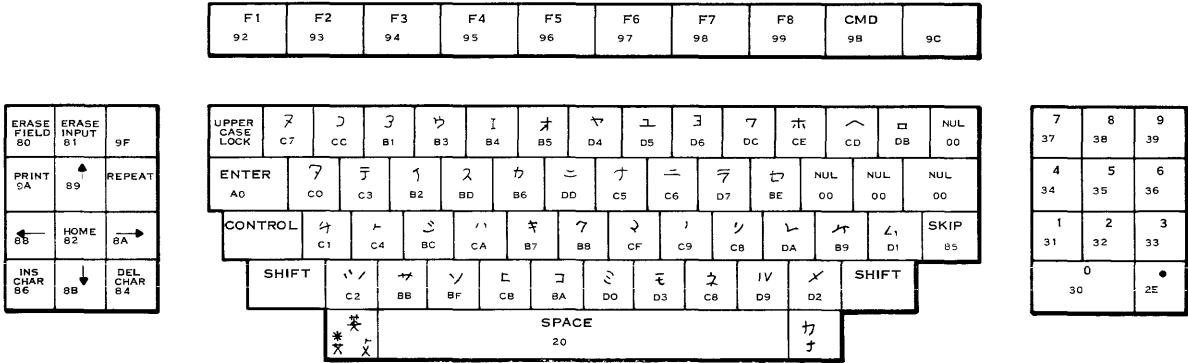

Figure F-7. Japanese Keyboard Showing Unshifted Katakana Character Positions and Hexadecimal Codes

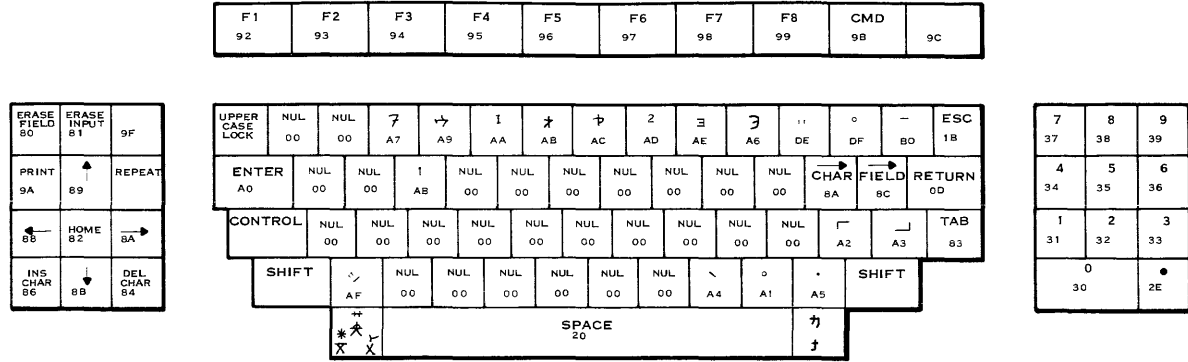

Figure F-8. Japanese Keyboard Showing Shifted Katakana Character Positions and Hexadecimal Codes



Table F-1. Japanese Katakana Modified ASCII (JIS-8) and Special Character Set

					b8	0	0	0	0	0	0	0	0	0	1	1	1	1	1	1	1	1
					b7	0	0	0	0	1	1	1	1	0	0	0	0	1	1	1	1	1
					b6	0	0	1	1	0	0	1	1	0	0	1	1	0	0	1	1	1
					b5	0	1	0	1	0	1	0	1	0	1	0	1	0	1	0	1	0
b4	b3	b2	b1		0	1	2	3	4	5	6	7	8	9	A	B	C	D	E	F		
0	0	0	0	0	NUL	DLE	SP	0	Q	P	\	p	ERASE FIELD	HERE IS	ENTER	-	タ	ミ				
0	0	0	1	1	SOH	DC1	!	1	A	Q	a	q	ERASE INPUT		o	ア	チ	ム				
0	0	1	0	2	STX	DC2	"	2	B	R	b	r	HOME	F1	[イ	ン	メ				
0	0	1	1	3	ETX	DC3	#	3	C	S	c	s	TAB	F2]	ウ	テ	モ				
0	1	0	0	4	EOT	DC4	\$	4	D	T	d	t	DEL CHAR	F3	,	エ	ト	ナ				
0	1	0	1	5	ENQ	NAK	%	5	E	U	e	u	SKIP	F4	,	オ	ナ	ユ				
0	1	1	0	6	ALK	SYN	&	6	F	V	f	v	INS CHAR	F5	ヲ	カ	ニ	ヨ				
0	1	1	1	7	BEL	ETB	'	7	G	W	g	w	FIELD ←	F6	ア	キ	ヌ	ラ				
1	0	0	0	8	BS	CAN	(8	H	X	h	x	CHAR ←	F7	イ	ク	ネ	リ				
1	0	0	1	9	HT	EM)	9	I	Y	i	y	↑	F8	ウ	ケ	ノ	ル				
1	0	1	0	A	LF	SUB	*	:	J	Z	j	z	CHAR →	PRINT	エ	コ	ハ	レ				
1	0	1	1	B	VT	ESC	+	;	K	[k	{	↓	CMD	オ	サ	ヒ	ロ				
1	1	0	0	C	FF	FS	,	<	L	¥	l		FIELD →		+	ツ	フ	ク				
1	1	0	1	D	CR	GS	-	=	M]	m	}			ユ	ス	ヘ	ン				
1	1	1	0	E	SO	RS	.	>	N	^	n	~			ヨ	セ	ホ	ハ				
1	1	1	1	F	SI	US	/	?	O	-	o	DEL			ツ	ソ	マ	o				

(A) 140716



8/0	8/1	8/2	8/3	8/4	8/5	8/6	8/7
							*** *** *** *** *** *** *** ***
***		*** ***	*** *** ***	*** *** *** ***	*** *** *** ***	*** *** *** *** *** ***	*** *** *** *** *** *** *** ***
8/8	8/9	8/A	8/B	8/C	8/D	8/E	8/F
*** *** *** *** *** *** *** ***	*** *** *** *** *** *** *** ***	*** *** *** *** *** *** *** ***	*** *** *** *** *** *** *** ***	*** *** *** *** *** *** *** ***	*** *** *** *** *** *** *** ***	*** *** *** *** *** *** *** ***	*** *** *** *** *** *** *** ***
9/0	9/1	9/2	9/3	9/4	9/5	9/6	9/7
* * *	** ** **	*** *** ***	**** **** ****	***** ***** *****	***** ***** *****	***** ***** *****	***** ***** *****
9/8	9/9	9/A	9/B	9/C	9/D	9/E	9/F
*** *** *** ***** ***** ***** *** *** *** *** ***	***** ***** ***** ***** ***** ***** ***** ***** ***** ***** *****	***** ***** ***** ***** ***** ***** ***** ***** ***** ***** *****	*** *** *** *** *** *** *** *** *** *** ***	*** *** *** *** *** *** *** *** *** *** ***	*** *** *** *** *** *** *** *** *** *** ***	* ** ** * * * * * * * * *	* * * * * * * * * * * *
A/0	A/1	A/2	A/3	A/4	A/5	A/6	A/7
			*** * *				***** * *** * *
	*** * *		*	*	*	*	*
A/8	A/9	A/A	A/B	A/C	A/D	A/E	A/F
* * * *	* **** * *	*** * *	**** * *	**** * *	**** * *	**** * *	**** * *
B/0	B/1	B/2	B/3	B/4	B/5	B/6	B/7
	*****	***** * ** * *	* ***** * * *	* ***** * * *	* ***** * * *	* ***** * * *	* ***** * * *
B/8	B/9	B/A	B/B	B/C	B/D	B/E	B/F
**** * * * *	* **** * * *	***** * * * *	** ***** * * *	** ***** * * *	**** * * * *	* ***** * * *	* ***** * * *

Figure F-9. Additional 128 Eight-Bit Characters Included in the Japanese Katakana Displayed Character Set (Sheet 1 of 2)

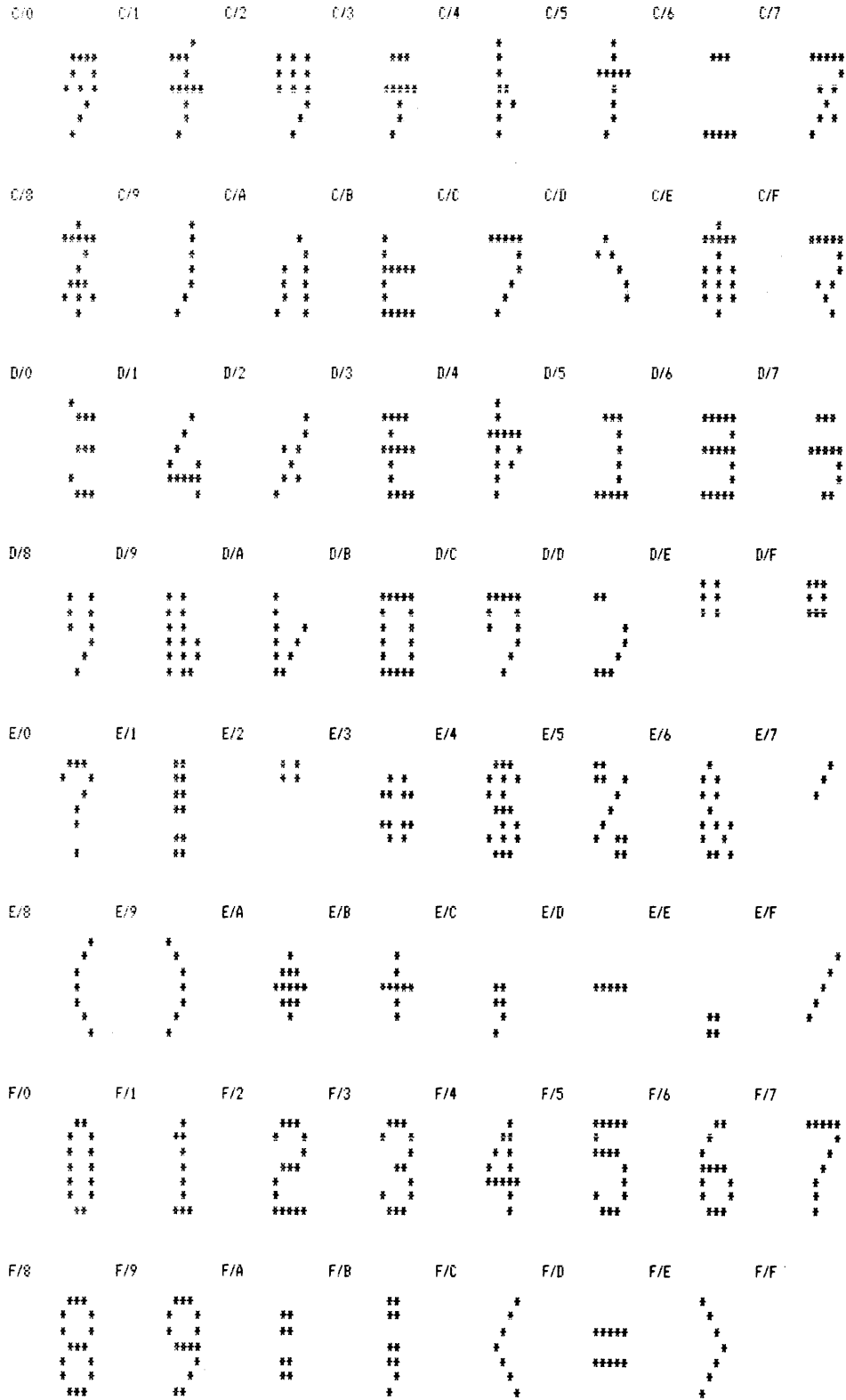

Figure F-9. Additional 128 Eight-Bit Characters Included in the Japanese Katakana Displayed Character Set (Sheet 2 of 2)



945423-9701

ALPHABETICAL INDEX



ALPHABETICAL INDEX

INTRODUCTION

The following index lists key words and concepts from the subject material of the manual together with the area(s) in the manual that supply major coverage of the listed concept. The numbers along the right side of the listing reference the following manual areas:

- Sections - References to Sections of the manual appear as "Section x" with the symbol x representing any numeric quantity.
- Appendixes - References to Appendixes of the manual appear as "Appendix y" with the symbol y representing any capital letter.
- Paragraphs - References to paragraphs of the manual appear as a series of alphanumeric or numeric characters punctuated with decimal points. Only the first character of the string may be a letter; all subsequent characters are numbers. The first character refers to the section or appendix of the manual in which the paragraph is found.
- Tables - References to tables in the manual are represented by the capital letter T followed immediately by another alphanumeric character (representing the section or appendix of the manual containing the table). The second character is followed by a dash (-) and a number:

Tx-yy

- Figures - References to figures in the manual are represented by the capital letter F followed immediately by another alphanumeric character (representing the section or appendix of the manual containing the figure). The second character is followed by a dash (-) and a number:

Fx-yy

- Other entries in the Index - References to other entries in the index are preceded by the word "See" followed by the referenced entry.



Address, Cursor	3.2.1, T3-1, T3-3	Data:	
Addresses, CRU Expansion Chassis	T2-2	CRU	F1-3
Alarm	1.2.3.4, F1-4	Display	1.3
Audible	1.2.3, 1.2.3.4, 1.2.4	Editing	1.3
Audio	1.2.3.3	Entry	1.3
Enable	F1-3	Indicators	4.3.2, F4-3, F4-4
ASCII Codes	1.1, T3-5	Keyboard	F1-3, T3-1
Beep Enable Strobe	T3-3	Screen Symbol	1.2.2
Bit Assignments, Computer Output	F3-4, F3-5	Storage	1.3
Blinking Cursor Enable	T3-3	Video	F1-3
Block Diagram, CRT Controller	F1-4	Delay:	
Brightness Control	2.7, 4.3.1, F4-2	Horizontal Sync	T1-1
Built-in-Test	F1-4, T3-2	Vertical Sync	T1-1
Cables	1.1, 1.2.4, 1.2.5, 2.7, F1-2	Dimensions, Physical	F2-1, T2-1
Cabling	2.4, F2-5	Display:	
Cabling Restrictions	2.2.2	Capacity	1.2.3.1
Character:		Characteristics	1.2.2, T1-1
Block	T1-1	Data	1.3
Capacity	1.2.2	Enable	T3-3
Code	4.3.2	Features	1.2.3.1
Font	1.2.3.1	Display Cursor	T3-3
Generation, Keyboard	1.2.1	Display Memory Read Character	3.2.1
Generator, Graphic	1.2.2	Display Memory Read Data	T3-1
Intensity	3.2.1	Display Memory Write Data	T3-3
Keyboard	3.2.1	Display Size:	
Lines	T1-1	Horizontal	T1-1
Matrix	T1-1	Vertical	T1-1
Positions, Displayed	T3-1	Display Unit	1.2.3
Rate	T1-1	Control Panel	F4-2
Set	1.1, 1.2.3.1, 1.2.4, 3.4, T3-5	Controls and Indicators	4.3
Characters, Graphic	1.1	Displayed Character Positions	T3-1
Characters Per Scan Line	T1-1	Displayed Character Set:	
Checkout	2.7	International	1.4, F1-7
Clear Screen Program	3.6.8	Japanese Katakana	1.1, 1.4, Appendix F
Code, Character	4.3.2	Positions	F3-3
Communication Register Unit	1.2.1	United States	1.4, F1-6
Computer Input Bit Assignments	F3-1, F3-2	Dot Rate	T1-1
Computer Output Bit Assignments	F3-4, F3-5	Dual Intensity	1.1, 1.2.3.1, 3.3, F3-1, F3-2, F3-5, T3-1
Computer/VDT Controller Interface	F3-4, F3-5	Echo Character to Screen Program	3.6.3
Configuration, System	F1-3	Enable:	
Control Bit, Keyboard Data	T3-1	Alarm	F1-3
Control Character Keyboard	F3-8	Blinking Cursor	T3-3
Control Key	3.4	Display	T3-3
Control Logic	1.2.3, 1.2.3.3	Hi/Lo Intensity	T3-3
Control Mode	4.2	Keyboard Interrupt	T3-3
Control Panel	4.3.1	Error:	
Display Unit	F4-2	Keyboard Parity	T3-1
Control ROM	1.2.2	Parity	T3-1
Controls and Indicators, Display Unit	4.3	European:	
CRT Display Unit	F1-3	Controller	1.1, F1-2
CRT Display Unit/VDT Controller		Extension Cable	1.1
Interface	1.2.5, F1-3	Mode Keys	4.2
CRT Monitor	1.2.3, 1.2.3.1	Expansion Chassis Addresses, CRU	T2-2
CRU	1.2.1	Features, Display	1.2.3.1
Data	F1-3	Flag, Previous State	T3-1
Expansion Chassis Addresses	T2-2	Font, Character	1.2.3.1
Cursor	3.5	French Model 911 VDT	Appendix B
Address	3.2.1, T3-1, T3-3	Frequency, Horizontal	T1-1
Blinking	1.2.3.1	Function Keys	1.2.4
Move	T3-3	Function Keys, Programmable	1-1
Pad	1.2.4		
Positioning	1.1		



Generator:		Lines:	
Graphic Character	1.2.2	Character	T1-1
Time-Base	1.2.2, F1-4	Scan	T1-1
German Model 911 VDT	Appendix C	Lower Case	1.1
Graphic:		Keyboard	F3-6
Character Generator	1.2.2	Mode	4.2
Characters	1.1		
		Matrix, Character	T1-1
Horizontal:		Memory	1.2.2, F1-4
Display Size	T1-1	Refresh	1.1
Frequency	T1-1	Modem Audio	F1-3
Horizontal Sync:		Monitor, CRT	1.2.3, 1.2.3.1
Delay	T1-1	Mounting Surface	2.2.1
Width	T1-1	Move Cursor Program	3.6.7
Indicators, Data	2.7, 4.3.2, F4-3, F4-4	Norwegian/Danish Model 911 VDT	Appendix E
Initialization, Screen	3.3	Numeric Pad	1.1, 1.2.4
Input Bits, VDT Controller	T3-1		
Input Data to Computer	3.2.1	On/Off Switch	4.3.1, F4-2
Installation	2.5	Options	1.2.2, 1.2.5, F1-4
VDT Controller	2.6.2	Output Bit Assignments, Computer	F3-4, F3-5
Intensity:			
Character	3.2.1	Parity	T3-1
Dual	1.1	Error	T3-1
Interfaces	1.2.1, F1-3, F1-4	Indicator	4.3.2, F4-3, F4-4
International Keyboards:		Physical Dimensions	F2-1, T2-1
French	Appendix B	Power Supply	1.2.3, 1.2.3.2
German	Appendix C	Power Transformer	1.2.3.2
Japanese Katakana	1.2.4, 3.4, 4.2, Appendix F	Previous State Flag	T3-1
Norwegian/Danish	Appendix E	Program:	
Swedish/Finnish	Appendix D	Clear Screen	3.6.8
United Kingdom	Appendix A	Echo Character to Screen	3.6.3
United States	1.1, 1.2.4, F1-5, T3-5, T4-1	Move Cursor	3.6.7
Interrupt Enable, Keyboard	T3-3	Polling Routine	3.6.1
Interrupts	2.6.3, T3-1	Read Character From Screen	3.6.4
		Read Keyboard Ready	3.6.2
		Restore Cursor Position	3.6.6
Japanese Katakana:		Programmable Function Keys	1.1
Controller	1.1, F1-2	Programming	3.1
Displayed Character Set	1.1, 1.2.3.1	Programs	3.6
KANJI Mode	1.1, 3.4, F3-1, F3-2, F3-4, F3-5, F3-6, T3-3, T4-2	Protect	1.1
Keyboard	1.2.4, 3.4		
Model 911 VDT	Appendix F	Raster Scan	1.2.3.1
		Read Character from Screen Program	3.6.4
Keyboard	1.1, 1.2.4, 4.2, F1-3, F1-4, F1-5, F4-1	Read Cursor Position Program	3.6.5
Character	3.2.1	Read Keyboard Ready Program	3.6.2
Character Generation	1.2.1	Refresh:	
Codes	3.4, T3-5	Image	1.2.2
Control Character	F3-8	Memory	1.1
Data	F1-3, T3-1	Rate	1.2.2, T1-1
Parity Error	T3-1	Regulators	1.2.3.2
Shift Mode Character	F3-9	Repeat	3.4
Upper Case	F3-7	Restore Cursor Position Program	3.6.6
Keyboard Data Control Bit	T3-1		
Keyboard Data Ready	T3-1	Scan Lines	T1-1
Keyboard Functions, Special	1.2.4	Screen Initialization	3.3
Keyboard Interrupt Enable	T3-3	Screen Symbol Data	1.2.2
Keyboard Modes	4.2	Select Word	T3-3
Keyboard/VDT Controller Interface	1.2.3.3	Self Test Signal	T3-1
Keyboard/VDT Display Unit Interface	F1-3	Shift Key	3.4
Keys, Programmable Function	1.1	Shift Mode	4.2
Kit, Terminal	1.1, F2-4	Shift Mode Character Keyboard	F3-9
		Site Requirements	2.2



Special Keyboard Functions	1.2.4	Displayed Character Set	1.4, F1-6
Status, Terminal	F1-3	Keyboard.	1.1, 1.2.4, 3.4, 4.2.1, F1-5, F2-4, F4-1, T3-5
Storage, Data	1.3	United Kingdom Model 911 VDT	Appendix A
Swedish/Finnish Model 911 VDT	Appendix D	Unpacking/Packing	2.3
System:		Upper Case.	1.1
Configuration	F1-3	Keyboard.	F3-7
Terminology.	1.2	Upper Case Lock Key.	3.4
Terminal Controller Interface	3.2	Upper Case Mode	4.2
Terminal Kit.	1.1, F2.4	Vertical Display Size	T1-1
Terminal Ready	T3-1	Vertical Sync:	
Terminal Status.	F1-3	Delay	T1-1
Terminology, System	1.2	Width	T1-1
Test Mode	T3-3	Video Data.	F1-3
Time-Base Generator	1.2.2, F1.4	Video Output Logic.	F1-4
Transformer, Power	1.2.3.2	Volume Control	2.7
United States:		Word Selection	T3-1, T3-3
Controller	F1-2		

FOLD



NO POSTAGE
NECESSARY
IF MAILED
IN THE
UNITED STATES

BUSINESS REPLY MAIL
FIRST CLASS PERMIT NO. 7284 DALLAS, TX

POSTAGE WILL BE PAID BY ADDRESSEE

TEXAS INSTRUMENTS INCORPORATED
DIGITAL SYSTEMS GROUP

ATTN: TECHNICAL PUBLICATIONS
P.O. Box 2909 M/S 2146
Austin, Texas 78769

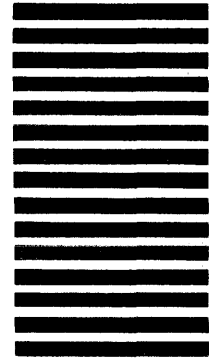

FOLD

DB9
MALE
WITH
POSTS

MADIISON WIRE & CABLE
STYLE NO. 2384 OR EQUAL

DB9
FEMALE
WITH
SCREWS

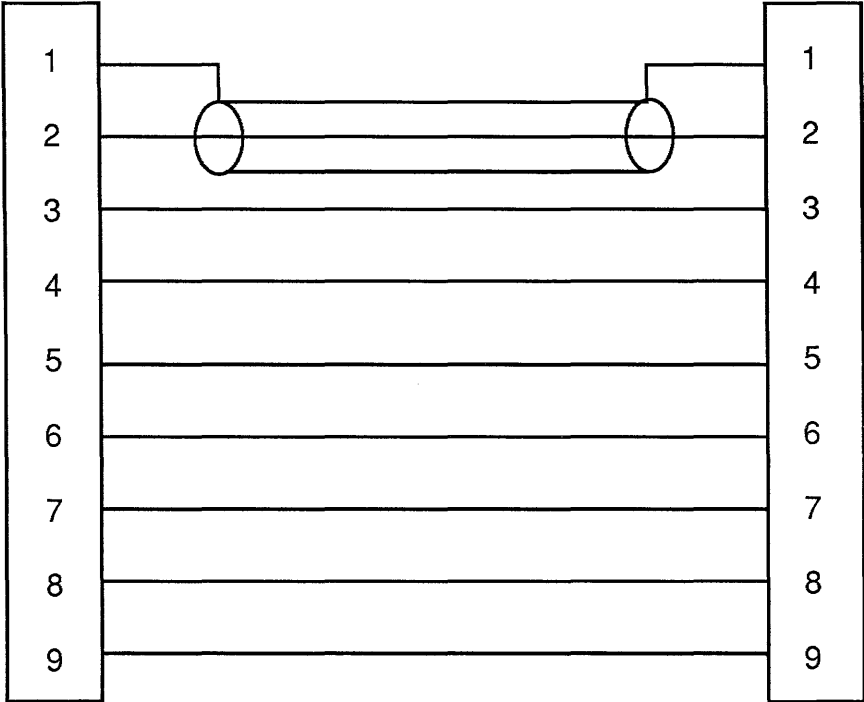

Texas Instruments U.S. District Sales and Service Offices

(A complete listing of U.S. offices is available from the district office nearest your location)

California

831 S. Douglas Street
El Segundo, California 90245
(213) 973-2571

100 California Street
Suite 480
San Francisco, California 94111
(415) 781-9470

776 Palomar Avenue
P.O. Box 9064
Sunnyvale, California 94086
(408) 732-1840*

3186 J Airway
Costa Mesa, California 92626
(714) 540-7311

Colorado

9725 East Hampden Avenue
Suite 301
Denver, Colorado 80231
(303) 751-1780

Florida

1850 Lee Road
Suite 115
Winter Park, Florida 32789
(305) 644-3535

Georgia

3300 Northeast Expressway
Building 9
Atlanta, Georgia 30341
(404) 458-7791

Illinois

515 West Algonquin Road
Arlington Heights, Illinois 60005
(312) 640-2900
(800) 942-0609*

Massachusetts

504 Totten Pond Road
Waltham, Massachusetts 02154
(617) 890-7400

Michigan

24293 Telegraph Road
Southfield, Michigan 48034
(313) 353-0830
(800) 572-8740*

Minnesota

7625 Parklawn Avenue
Minneapolis, Minnesota 55435
(612) 830-1600

Missouri

2368 Schuetz
St. Louis, Missouri 63141
(800) 392-4225*

New Jersey

1245 Westfield Avenue
Clark, New Jersey 07066
(201) 574-9800

Ohio

4124 Linden Avenue
Dayton, Ohio 45432
(513) 258-3877

Pennsylvania

420 Rouser Road
Coraopolis, Pennsylvania 15108
(412) 771-8550

Texas

8001 Stemmons Expressway
P.O. Box 226080
M/S 3108
Dallas, Texas 75266
(214) 689-4460

13536 North Central Expressway
P.O. Box 5012
M/S 917
Dallas, Texas 75222
(214) 238-3881

9000 Southwest Freeway
P.O. Box 1444
M/S 6500
Houston, Texas 77001
(713) 776-6577

8585 Commerce Drive, Suite 518
Houston, Texas 77036
(713) 776-6511

Virginia

1745 Jefferson Davis Highway
Crystal Square 4, Suite 600
Arlington, Virginia 22202
(703) 553-2200

Wisconsin

205 Bishops Way
Suite 214
Brookfield, Wisconsin 53005
(414) 784-1323

*Service telephone number

TI-CARE*

**Centralized Dispatch Telephone Numbers
for Requesting Service**

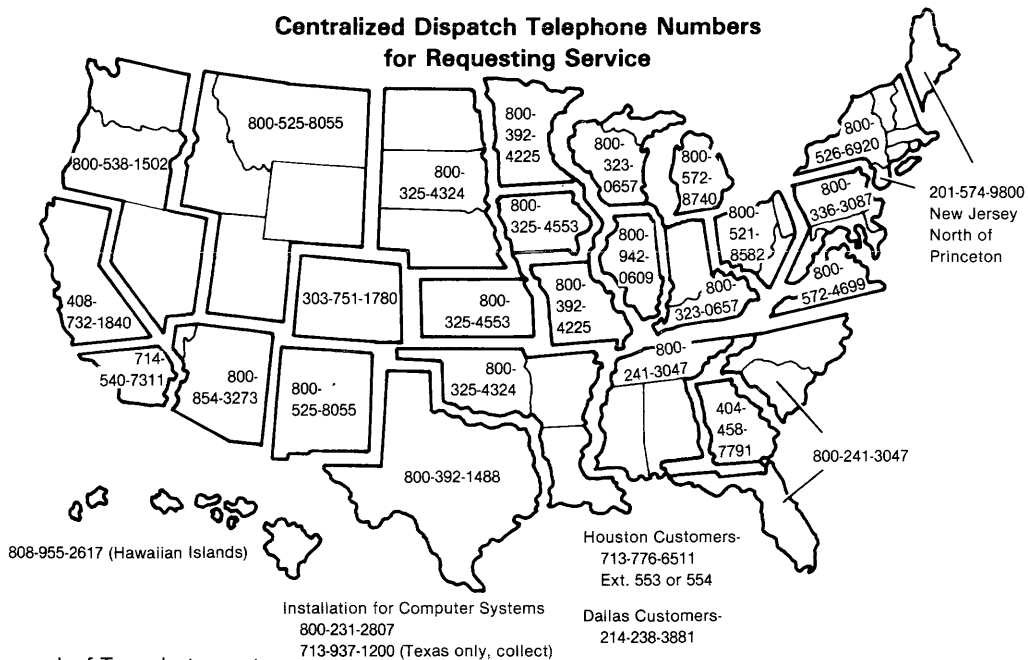

*Service mark of Texas Instruments

The TI Customer Support Line is available to answer our customers' complex technical questions. The extensive experience of a selected group of TI senior engineers and systems analysts is made available directly to our customers. The TI Customer Support Line telephone number is (512) 250-7407.



TEXAS INSTRUMENTS
INCORPORATED

DIGITAL SYSTEMS GROUP
POST OFFICE BOX 2909 AUSTIN, TEXAS
