

USER'S MANUAL



***Model 880
and Model 880 DP
Printers***

222730-0001
October 1985

TEXAS INSTRUMENTS

**Copyright © 1985 by Texas Instruments Incorporated
All Rights Reserved – Printed in USA**

The information and/or drawings set forth in this document and all rights in and to inventions disclosed herein and patents which might be granted thereon disclosing or employing the materials, methods, techniques or apparatus described herein are the exclusive property of Texas Instruments Incorporated.

No copies of this information or drawings shall be made without the prior consent of Texas Instruments Incorporated.

Model 880 and Model 880 DP Printers User's Manual
TI Part No. 2222730-0001
Original Issue: February 1985

CHANGE NOTICES				
Revision Letter	Date	ECN		Description
		Number	Level	
A	3/85	534996	B	Correct text according to ECN
B	6/85	486978	C	Correct text according to ECN
C	10/85	532611	E	Add 880 DP information

IMPORTANT

Record on the lines provided below the model number and serial number of your unit. The serial number is identified by the words "Serial No." on the label located on the unit. The model number is located on the line above the part number. This information is to be recorded and retained for future reference.

Model Number _____

Serial Number _____

CAUTION

To comply with FCC part 15, subpart J, electromagnetic interference requirements for computing devices, a shielded signal cable is required for either serial or parallel operation of the Model 880 printer. TI cable part number 2223106-0001 for parallel operation or part number 2230504-0001 for serial operation or equivalent should be used. Failure to use the properly shielded cables may result in radio frequency interference in excess of the levels allowed by law. The user of equipment found to be out of compliance would be liable for any interference and corrective action to eliminate that interference.

Preface

This manual describes the installation, operation, limited maintenance, and software control of the Texas Instruments *OMNI 800** Model 880 and Model 880 DP Printers. All references in this manual to the Model 880 Printer include the Model 880 DP Printer, unless otherwise specified.

Section 1, INTRODUCTION — Provides a short summary of the Model 880 Printer features, and shows sample printouts.

Section 2, INSTALLATION — Describes how to install and prepare the printer for operation.

Section 3, CONTROL PANEL OPERATION — Describes how to use the operator panel to select printer features and printer configuration.

Section 4, PROBLEM ANALYSIS — Describes the Test mode, status report, defines diagnostic error codes, and outlines troubleshooting procedures.

Section 5, SOFTWARE COMMANDS — Describes software control of the printer, including control characters and escape sequences.

Section 6, RASTER GRAPHICS — Describes escape sequences and control characters for horizontal and vertical raster graphics.

Section 7, COMMUNICATION INTERFACES — Describes serial and parallel communication interfaces.

The appendixes discuss:

A — TI Business Systems

B — Maintenance

C — Control and Character Codes

D — Power Requirements and Grounding

E — Options and Accessories

F — Specifications

Other Documents

The document below provides additional information for the Model 880 Printer:

Model 880 Printer Maintenance Manual
(TI Part No. 2222628-0001)

To receive a copy, send a request (purchase order) to:

Texas Instruments Incorporated
Terminal Spare Parts - M/S 7793
P.O. Box 1444
Houston, Texas 77251

* Trademark of Texas Instruments Incorporated.



Table of Contents

Section	Title	Page	Section	Title	Page
Preface					
1	Introduction				
1.1	Features	1-1			
1.2	Sample Printouts	1-2			
2	Installation				
2.1	Unpacking the Printer	2-1			
2.2	Installing the Printer	2-2			
2.3	Installing the Paper Basket	2-2			
2.4	Installing the Ribbon	2-4			
2.5	Loading the Paper	2-5			
2.6	Connecting the Power Cable	2-6			
2.7	Activating the Printer	2-7			
2.8	Adjusting the Printhead	2-7			
2.9	Printing the Barberpole	2-8			
2.10	Connecting the Data Cable	2-9			
3	Control Panel Operation				
3.1	Normal Mode	3-1			
3.2	Command Mode	3-1			
3.2.1	Setting Form Length	3-4			
3.2.2	Setting and Clearing Vertical Tabs	3-4			
3.3	Menu Mode	3-4			
3.3.1	The Form Report and Menu	3-5			
3.3.1.1	Form Features	3-6			
3.3.1.2	Changing Form Features	3-6			
3.3.1.3	Checking Host-Controlled Margins	3-8			
3.3.2	The Configuration Report and Menu	3-8			
3.3.2.1	Configuration Codes	3-9			
3.3.2.2	Changing Configuration Codes	3-9			
3.3.3	The Character Set Report and Menu	3-13			
3.3.3.1	Character Set Designations	3-15			
3.3.3.2	Changing Character Set Selections	3-15			
3.4	Print Features Switch	3-16			
3.4.1	Programmable Positions A - F	3-17			
3.4.2	Programmable Position Default Form Lengths	3-17			
3.5	Default Features	3-18			
4	Problem Analysis				
4.1	Test Mode	4-1			
4.1.1	The Status Report	4-1			
4.1.2	Error Codes	4-2			
4.1.3	The Barberpole Test	4-5			
4.2	Troubleshooting	4-5			
5	Software Commands				
5.1	Control Characters	5-1			
5.2	Single-Pass Overstrikes	5-3			
5.3	Escape Sequences	5-3			
5.3.1	Form Length Escape Sequences	5-3			
5.3.2	Margin Control Escape Sequences	5-4			
5.3.3	Horizontal Tab Escape Sequences	5-5			
5.3.4	Vertical Tab Escape Sequences	5-5			
5.3.5	Horizontal Pitch Escape Sequences	5-5			
5.3.6	Vertical Pitch Escape Sequences	5-6			
5.3.7	Printer Status Escape Sequences	5-6			
5.4	Character Set Extension	5-7			

Section	Title	Page	Section	Title	Page
5.4.1	Seven-Bit Environment	5-7	7.2.2	Serial Connector Pin Listing	7-3
5.4.2	Eight-Bit Environment	5-9	7.3	Parallel Interface	7-3
6	Raster Graphics		7.3.1	Parallel Connector Pin Listing	7-3
6.1	Vertical Raster Graphics	6-1	7.3.2	Parallel Data Timing	7-6
6.2	Horizontal Raster Graphics	6-4	7.3.3	Paper-Out and Mechanism Faults	7-6
6.2.1	Horizontal Raster Data Format/ Single-Density Plot Mode	6-4	7.3.4	Sequence to Initialize the Printer	7-6
6.2.2	Horizontal Raster Data Format/ Double-Density Plot Mode	6-5			
7	Communication Interfaces		Appendixes		
7.1	Data Input Buffer	7-1	A	TI Business Systems	
7.2	Serial Interface	7-3	B	Maintenance	
7.2.1	Data Structure	7-3	C	Control and Character Codes	
			D	Power Requirements and Grounding	
			E	Options and Accessories	
			F	Specifications	

List of Tables

Table No.	Title	Page	Table No.	Title	Page
3-1	Configuration Codes	3-12	5-11	Printer Status Escape Sequences	5-6
3-2	Characters Per Line	3-13	5-12	Escape Sequences For Character Set Designation	5-10
3-3	Default Form Lengths	3-17	5-13	Escape Sequences For Character Set Invocation	5-11
3-4	Print Features Switch Defaults	3-18	5-14	Special Character Selection Commands	5-11
3-5	Default Configuration Codes	3-18	5-15	Font ROM Positions	5-11
3-6	Default Character Set Designations	3-18	6-1	Vertical Raster Graphics Eight-bit Data-to-Dot Map	6-1
4-1	Error Codes	4-3	6-2	Vertical Raster Graphics Seven-Bit Data-to-Dot Map	6-1
4-2	Problem Analysis Procedures	4-6	6-3	Escape Sequences for Vertical Raster Graphics	6-2
5-1	ASCII Chart with Decimal and Hexadecimal Codes	5-1	7-1	Buffer Size and READY/BUSY Points	7-1
5-2	Control Character Operations	5-2	7-2	READY/BUSY Signals	7-2
5-3	Form Length Escape Sequences	5-4	7-3	Serial Interface Signals	7-4
5-4	Margins and Defaults	5-4	7-4	Parallel Interface Signals	7-5
5-5	Margin Control Escape Sequences	5-4	C-1	ASCII Code Characters	C-1
5-6	Horizontal Tab Escape Sequences	5-5	C-2	National Language Characters that Differ from US ASCII Characters	C-2
5-7	Vertical Tab Escape Sequences	5-5			
5-8	Horizontal Pitch Escape Sequences	5-6			
5-9	Characters Per Line	5-6			
5-10	Vertical Pitch Escape Sequences	5-6			

List of Illustrations

Figure No.	Title	Page	Figure No.	Title	Page
1-1	Texas Instruments Model 880 Printer	1-1	3-6	Programmable Position 'E'	3-17
1-2	Sample Printout (Models 880 or 880 DP)	1-2	4-1	TEST MODE	4-1
1-3	Sample Printout (Model 880)	1-2	4-2	The Barberpole Test	4-5
1-4	Sample Printout (Model 880 DP) ...	1-2	5-1	Seven-Bit Character Set Table	5-7
2-1	Printer, Ribbon, Power Cable, User's Manual and Quick Reference Card	2-1	5-2	Seven-Bit Code Extension	5-8
2-2	Model 880 Printer Dimensions	2-2	5-3	Eight-Bit Character Set Table	5-9
2-3	Open the Printhead Door	2-3	5-4	Eight-Bit Code Extension	5-10
2-4	Installation of the Printer Paper Basket	2-3	6-1	Horizontal Graphics - Single Density	6-4
2-5	Printhead Adjustment Lever	2-4	6-2	Horizontal Graphics - Double Density	6-5
2-6	Ribbon Path	2-4	7-1	Seven-Bit Serial Data Structure	7-3
2-7	Ribbon-Reversing Eyelet	2-4	7-2	Eight-Bit Serial Data Structure	7-3
2-8	Loading the Paper	2-5	7-3	Parallel Interface Electrical Characteristics	7-7
2-9	Left and Right Tractors	2-5	7-4	Parallel Data Communication Timing	7-7
2-10	Power Switch and Identification Label	2-6	7-5	Going On Line and Off Line Timing	7-8
2-11	Three-Wire Power Receptacle	2-7	7-6	Timing Sequence to Initialize Printer	7-8
2-12	Printhead Adjustment Lever	2-8	A-1	System 200/300 and 931/940 Interface Diagram	A-2
2-13	Barberpole Printout	2-8	A-2	System 600 and 800 Interface Diagram	A-3
2-14	Data Cable Connectors	2-9	C-1	ASCII Control Characters	C-3
3-1	NORMAL MODE	3-2	D-1	AC Power Network and Ground	D-2
3-2	COMMAND MODE	3-3	D-2	Locations of Printer Cover Screws	D-3
3-3	MENU MODE (Form Menu)	3-5	D-3	Signal Ground/Protection Ground Jumper Plug	D-3
3-4	The Form Report	3-5			
3-4	MENU MODE (Configuration Menu)	3-8			
3-5	MENU MODE (Character Set Menu)	3-14			

Section 1

Introduction

1.1 FEATURES

Your Texas Instruments Model 880 Printer is a versatile, high-speed, serial-matrix impact printer that provides both draft font and enhanced font printout.

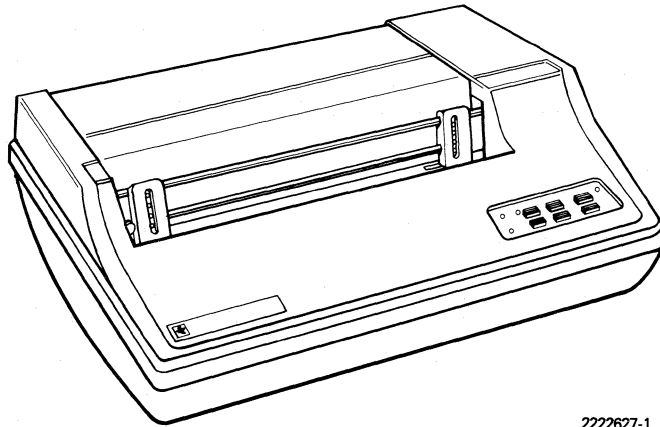

2222627-1

Figure 1-1. Texas Instruments Model 880 Printer

Some of the Model 880 Printer features are:

- 300 characters-per-second bidirectional printing
- Multiple character set selection (alternate character sets optional)
- 7-by-9 dot-matrix characters with true descenders
- 15-by-18 dot matrix enhanced characters on the Model 880 Printer
- 15-by-9 dot matrix enhanced characters on the Model 880 DP Printer
- Complete format selection from menu display
- Complete configuration selection from menu display
- Vertical and horizontal dot-format graphics
- Parallel and serial interface
- Extensive power-up self-testing of RAM, ROM, and communication logic
- Printer stand (optional)
- Paper tray (optional)

1.2 SAMPLE PRINTOUTS

The Model 880 prints draft font at 5, 6, 8-1/3, 10, 12, or 16-2/3 characters per inch (cpi) and enhanced font printout at 5, 6, 10 and 12 cpi. Examples are shown in Figures 1-2, 1-3, and 1-4.

This is draft print at 5 cpi.

This is draft print at 6 cpi.

This is draft print at 8 1/3 cpi.

This is draft print at 10 cpi.

This is draft print at 12 cpi.

This is draft print at 16 2/3 cpi.

Figure 1-2. Sample Printout (Models 880 or 880 DP)

This is enhanced print at 5 cpi.

This is enhanced print at 6 cpi.

This is enhanced print at 10 cpi.

This is enhanced print at 12 cpi.

Figure 1-3. Sample Printout (Model 880)

This is enhanced print at 5 cpi.

This is enhanced print at 6 cpi.

This is enhanced print at 10 cpi.

This is enhanced print at 12 cpi.

Figure 1-4. Sample Printout (Model 880 DP)

Section 2

Installation

This section describes how to install the Model 880 Printer and prepare it for operation. The installation procedures include:

1. Unpacking the printer
2. Installing the printer
3. Installing the paper basket
4. Installing the ribbon
5. Loading the paper
6. Connecting the power cable
7. Activating the printer
8. Adjusting the printhead
9. Printing the barberpole
10. Connecting the data cable

2.1 UNPACKING THE PRINTER

Inspect the contents of your shipping container.

1. Check the container and make a note of any damage.
2. Remove the ribbon and power cable from the plastic bag that contained this manual.
3. If the accessory paper basket for use with the printer was part of your order, it is packed with the printer. Remove the basket from the container.
4. Check for the components shown in Figure 2-1. Report any damaged components to the company that delivered your printer.

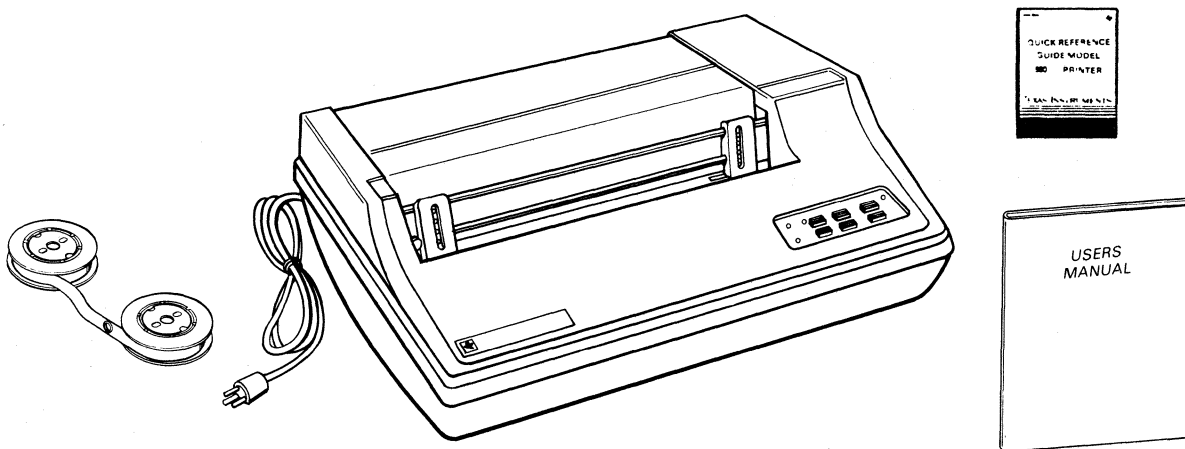

Figure 2-1. Printer, Ribbon, Power Cable, User's Manual, and Quick Reference Card

2222627-4

2.2 INSTALLING THE PRINTER

With all components unpacked and accounted for, follow these steps to prepare the printer for operation.

1. Set the printer on a level surface that is able to safely support 25 kg (55 lb). If the printer is put on a metal surface, the metal must be grounded to prevent electrical interference. Be sure that the weight of the printer is not pressing on the back paper chute.

CAUTION

Do not obstruct the air intake and exhaust vents on the sides of the printer; damage to the printer from heat can occur. Figure 2-2 shows the printer dimensions.

2. If you ordered the optional Texas Instruments printer stand (TI part number 999841-0001), fasten the printer to the stand according to the assembly instructions provided with the stand.
3. If you ordered the optional Texas Instruments stand-mounted paper basket kit (TI part number 999839-0001), mount the paper basket on the printer stand according to the assembly instructions provided with the paper basket kit.

4. Open the printhead door (Figure 2-3) and remove the cardboard shipping material from the printhead.
5. Manually slide the printhead from side to side. Be sure that the printhead and connected wire rope move freely.
6. Close the printhead door.

2.3 INSTALLING THE PAPER BASKET

1. Install the accessory paper basket kit (TI part number 994442-0001) as shown in Figure 2-4.
2. Fasten the basket to the printer by compressing the basket and inserting the pivot pins into the holes on the back of the printer.

NOTE

If you are not installing the paper basket accessory, you must provide another suitable method for holding the printer output. For correct printer operation, any other paper holding device must be connected to printer ground to prevent electrostatic discharge.

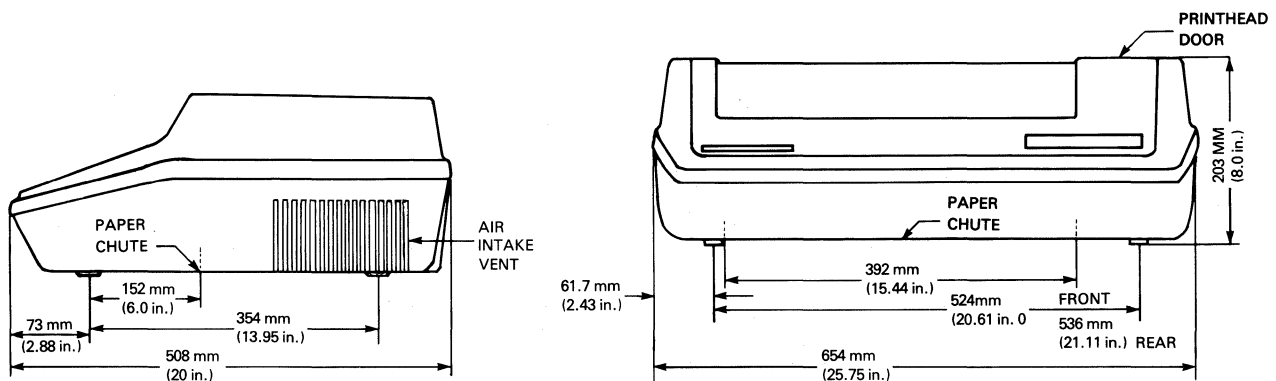
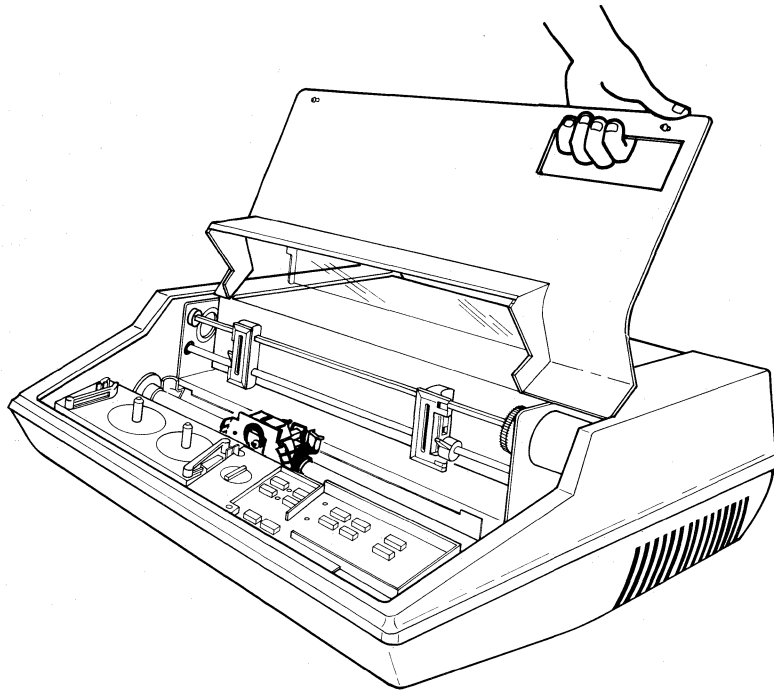

Figure 2-2. Model 880 Printer Dimensions

2222627-5



7222627-6

Figure 2-3. Open the Printhead Door

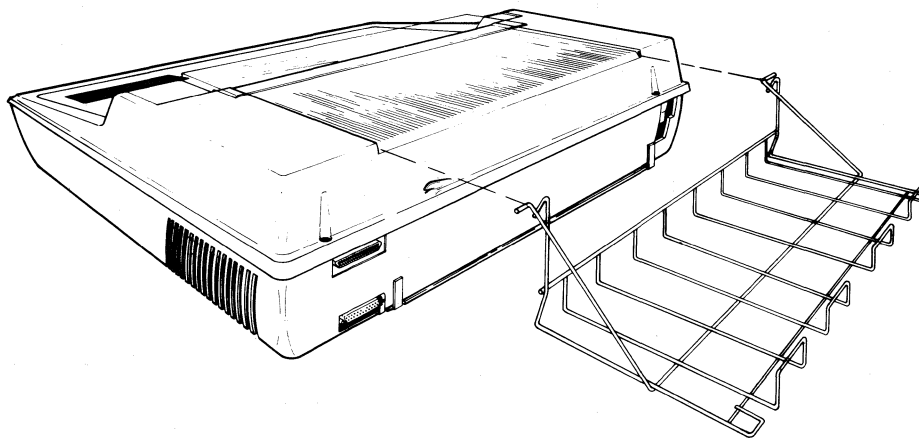

7222627-7

Figure 2-4. Installation of the Printer Paper Basket

2.4 INSTALLING THE RIBBON

CAUTION

Use of ribbon not meeting TI specification 2246601 can cause excessive printhead wear and may void warranty. (TI ribbon Part No. 2246601.)

Follow these steps to install a new ribbon.

1. Set the power switch to the **OFF** position.
2. Open the printhead door.
3. Make a note of the position of the printhead adjustment lever. Then move the lever away from the platen by pushing the lever slightly to the right and then pulling it to the front of the printer as shown in Figure 2-5.

NOTE

Make sure that the ribbon-reversing eyelet (Figure 2-7) is between the left ribbon-reversing arm and the left spool hub; if it is not, the ribbon will not reverse. Also make sure that the ribbon rides on the ribbon guides and inside the left end-plate.

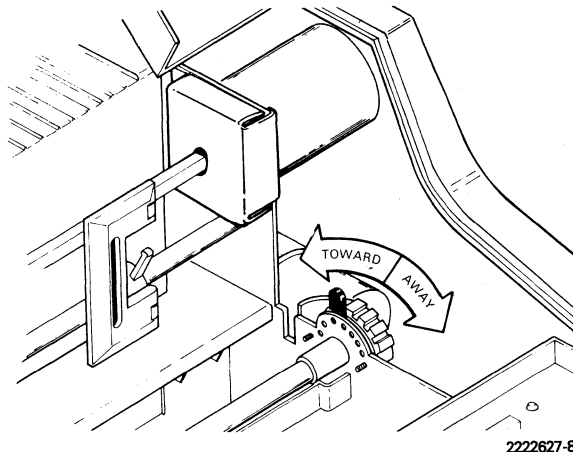

Figure 2-5. Printhead Adjustment Lever

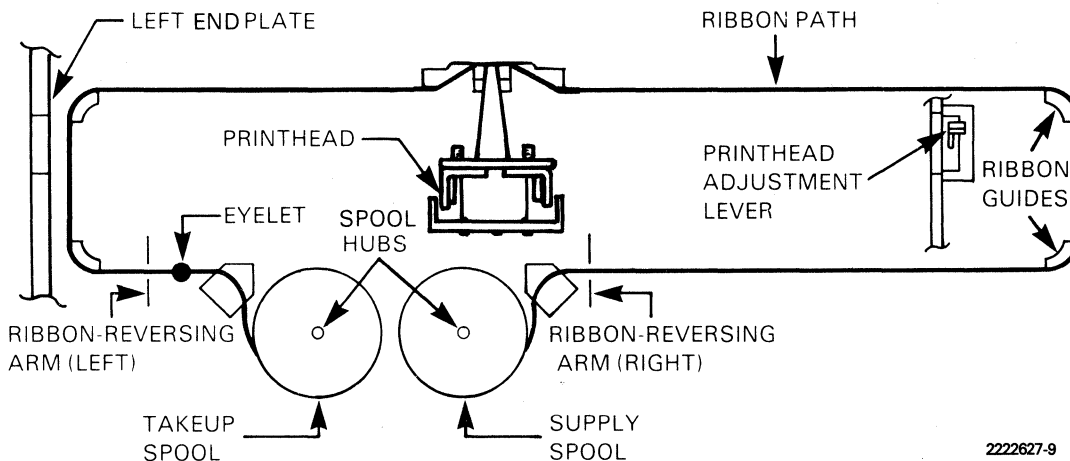

Figure 2-6. Ribbon Path

4. Lift the old ribbon spools off the hubs and lift the ribbon out of the ribbon path.
5. Set the empty spool of the new ribbon on the left spool hub with the ribbon toward the front of the printer. Pass the ribbon out along the ribbon path as shown in Figure 2-6.

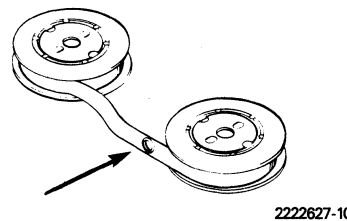

Figure 2-7. Ribbon-Reversing Eyelet

6. Set the full spool on the right hub. Rotate the hubs to pull the ribbon tight.
7. Return the printhead adjustment lever to its original position (step 3), or follow the "ADJUSTING THE PRINTHEAD" procedure in subsection 2.8.

2.5 LOADING THE PAPER

The Model 880 Printer has a bottom and rear paper path (see Figure 2-8). Either path can be used for single-thickness forms. The bottom path is recommended for multiple-thickness forms. To

load paper, refer to Figures 2-8 and 2-9 and complete the following steps.

1. Open the printhead door.
2. The left tractor must be to the left of the paper-out switch (Figure 2-8). If it is not, loosen the locking lever (Figure 2-9) and slide the left tractor to the left so that when the paper is installed, the paper will cover the paper-out switch. Tighten the lock lever.
3. Open the covers on both tractors.

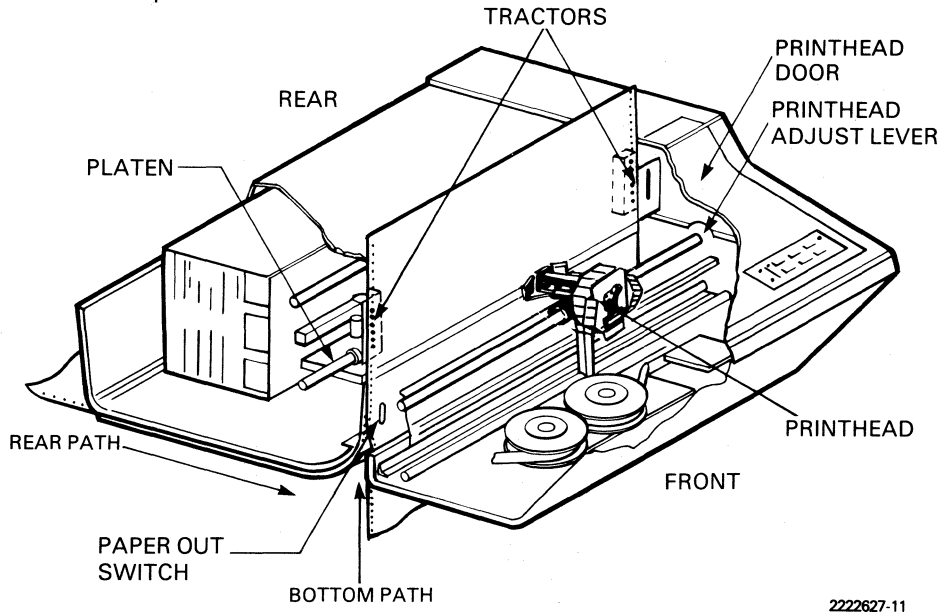

2222627-11

Figure 2-8. Loading the Paper

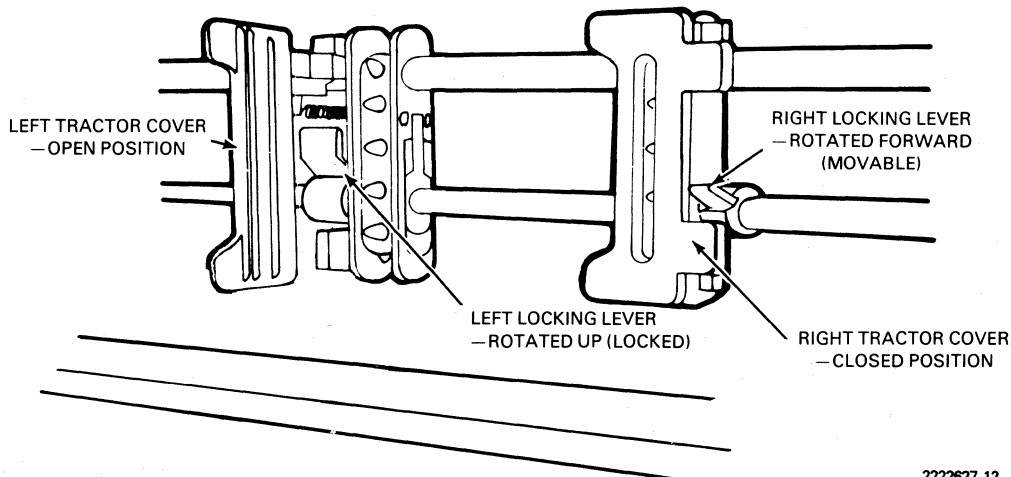

2222627-12

Figure 2-9. Left and Right Tractors

4. Use the printhead-adjustment lever to move the printhead away from the platen.
5. *To load paper through the back paper path,*
 - a. Put the paper supply in back of the printer.
 - b. Insert the paper, with the side to be printed facing down, into the paper path at the back of the printer until the paper appears at the platen. Align the paper so that it does not rub against the sides of the paper path.
 - c. Go to step 7.
6. *To load paper through the bottom path,*
 - a. Put the paper supply under the table or stand.
 - b. Insert the paper, with the side to be printed facing forward, into the bottom paper path until the paper appears at the platen. Align the paper so that it does not rub against the sides of the table slot or the sides of the bottom paper path.
 - c. Go to step 7.
7. Loosen the locking lever on the right tractor and adjust the tractor to accept the paper width.
8. Put the paper in both tractors with the holes on the tractor pins. Make sure you place corresponding holes on corresponding pins.
9. Close the tractor covers and move the right tractor to pull the paper tight across the platen. Then tighten the locking lever.
10. Check the alignment of the paper supply with the paper path. Paper must not touch either side of the path.
11. Return the printhead to its original position (step 4) using the printhead adjustment lever.

NOTE

To prevent possible damage to the printhead and platen, do not operate the printer without a ribbon and paper, or beyond the width of the paper.

2.6 CONNECTING THE POWER CABLE

Make sure that the printer is adequately grounded by plugging the power cable into a three-wire power receptacle.

CAUTION

Refer to the identification label on the back of your printer for correct voltage levels. An incorrect voltage can cause damage to the printer.

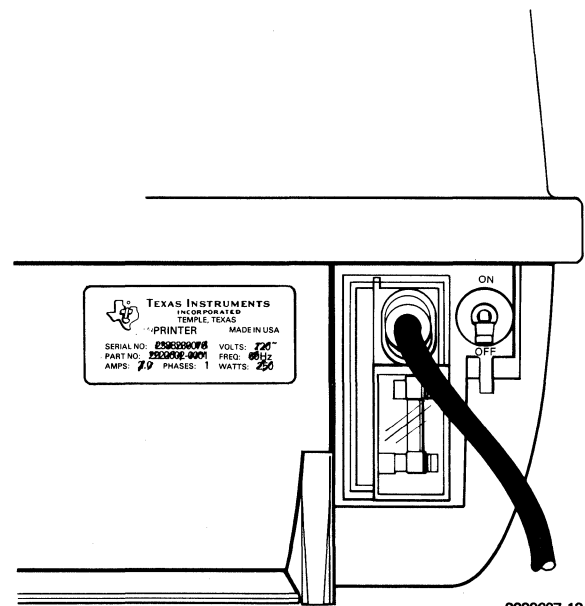
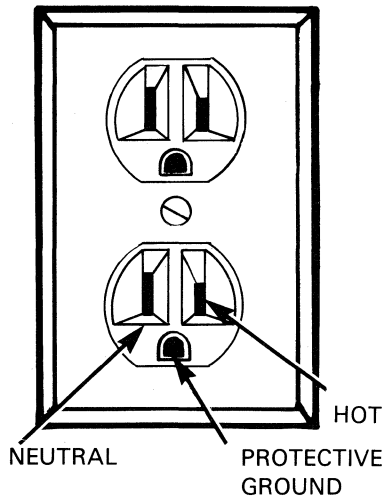

Figure 2-10. Power Switch and Identification Label

1. Set the power switch to the **OFF** position.
2. Connect the power cable to the printer by firmly pushing the female end of the cable into the printer.
3. Connect the other end of the power cable to the proper three-wire receptacle.



2222627-14

Figure 2-11. Three-Wire Power Receptacle

CAUTION

The printer must be connected to a three-wire (with earth-ground) ac receptacle. If an extension cable is needed, the cable must be a three-wire cable which includes an earth-ground connection. Failure to provide an earth ground can cause faulty operation, data errors, possible damage to the printer, and possible electrical hazard to the operator.

2.7 ACTIVATING THE PRINTER

CAUTION

Before activating your printer, allow at least 15 minutes after unpacking for it to adapt to ambient temperature and humidity.

When the power switch is put in the **ON** position, the printer does an automatic test that takes about 30 seconds. While the test is being done, the following events should occur:

1. All indicator lights (except **Command**) turn on.
2. Indicator lights turn off in the following order:
 - a. **On Line**
 - b. **Paper Out**
 - c. **Test**
 - d. **Menu**
 - e. **Error**
3. The carriage moves to the right bumper and then to the left bumper.
4. The printer makes a short audible tone.
5. The **Power** and **Normal** indicators remain on. The **Paper-Out** indicator flashes if you have not loaded paper. The **On Line** indicator turns on if the printer is configured to power-up on line (configuration code 9B selected).

If your printer does its automatic power-up test without these results, see Section 4, "STATUS REPORT AND PROBLEM ANALYSIS."

2.8 ADJUSTING THE PRINTHEAD

The printhead must be adjusted to the thickness of the form used. For the initial adjustment, and to make corrections for different paper thicknesses, complete the following steps:

1. After loading paper, move the printhead toward the platen by pushing the printhead adjustment lever slightly to the right and then toward the back of the printer. Allow the printhead barely to touch the paper.

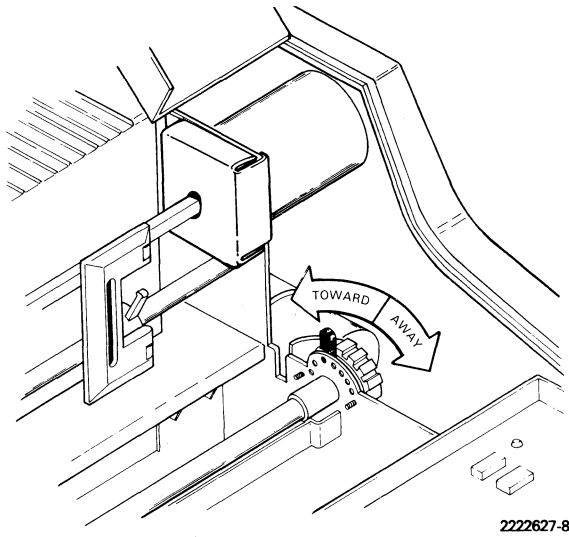

2222627-8

Figure 2-12. Printhead Adjustment Lever

2. Print a barberpole test (described in subsection 2.9). Ink smears will appear on the paper if the printhead is too close to the platen. Incomplete characters or no characters will appear if the printhead is too far from the platen.
3. Continue adjusting the printhead and printing barberpole tests until the print appears sharp and dark.

NOTE

Adjusting the printhead cannot compensate for a worn-out ribbon. Replace the ribbon if the printed characters are too light.

2.9 PRINTING THE BARBERPOLE

Before printing the barberpole test, the printer must be off line. If the **On Line** indicator is on, press the **On Line** key once to set the printer off line.

To print a barberpole test, sequentially press the **Normal**, **Command**, **Test**, and **Change** keys.

To stop the barberpole test, press the **Accept** or the **Normal** key.

NOTE

If a current loop or an RS422 Interface option is installed, a parity error, code 24, may occur. This error does not affect printer operation.

```

^()*+,-./0123456789:;<=>?@ABCDEFGHIJKLMN OPQRSTUVWXYZ[\]^_`abcdefg
() *+,-./0123456789:;<=>?@ABCDEFGHIJKLMN OPQRSTUVWXYZ[\]^_`abcdefg
) *+,-./0123456789:;<=>?@ABCDEFGHIJKLMN OPQRSTUVWXYZ[\]^_`abcdefg
*+,-./0123456789:;<=>?@ABCDEFGHIJKLMN OPQRSTUVWXYZ[\]^_`abcdefg
+,-./0123456789:;<=>?@ABCDEFGHIJKLMN OPQRSTUVWXYZ[\]^_`abcdefg
,-./0123456789:;<=>?@ABCDEFGHIJKLMN OPQRSTUVWXYZ[\]^_`abcdefg
-./0123456789:;<=>?@ABCDEFGHIJKLMN OPQRSTUVWXYZ[\]^_`abcdefg
./0123456789:;<=>?@ABCDEFGHIJKLMN OPQRSTUVWXYZ[\]^_`abcdefg
/0123456789:;<=>?@ABCDEFGHIJKLMN OPQRSTUVWXYZ[\]^_`abcdefg
0123456789:;<=>?@ABCDEFGHIJKLMN OPQRSTUVWXYZ[\]^_`abcdefg
123456789:;<=>?@ABCDEFGHIJKLMN OPQRSTUVWXYZ[\]^_`abcdefg
23456789:;<=>?@ABCDEFGHIJKLMN OPQRSTUVWXYZ[\]^_`abcdefg

```

Figure 2-13. Barberpole Printout

2222627-15

2.10 CONNECTING THE DATA CABLE

Two data cable connectors (serial and parallel) on the back of the Model 880 Printer are shown in Figure 2-14. Section 7 describes the communication interfaces and contains data cable pin definitions. Determine which interface and data cable you need for your system. Appendix A contains TI Business Systems installation instructions.

The serial interface connector has screw fasteners. The parallel interface connector is fastened by wire clips on the printer.

Use the following procedure to install your data cable:

1. Set the power switch (Figure 2-10) to the **OFF** position or disconnect the power cable from the receptacle.

2. Insert the data cable into the connector at the back of the printer.
3. As appropriate, tighten the screws on each side of the connector with a small screwdriver, or press the wire clips in place.

CAUTION

Connecting the cable without tightening the screws or engaging the clips can cause faulty operation.

4. Fasten the other end of the cable to the data set or computer. Make sure the connector is tight.

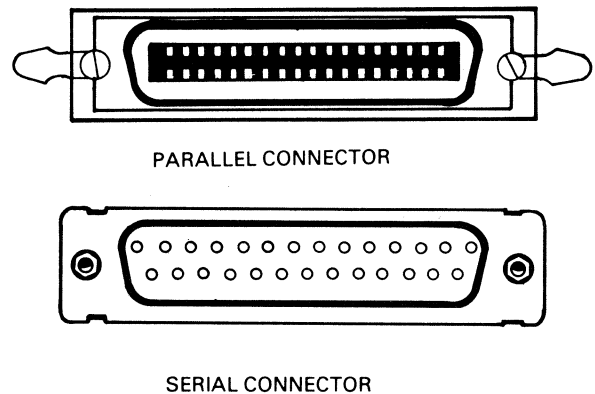
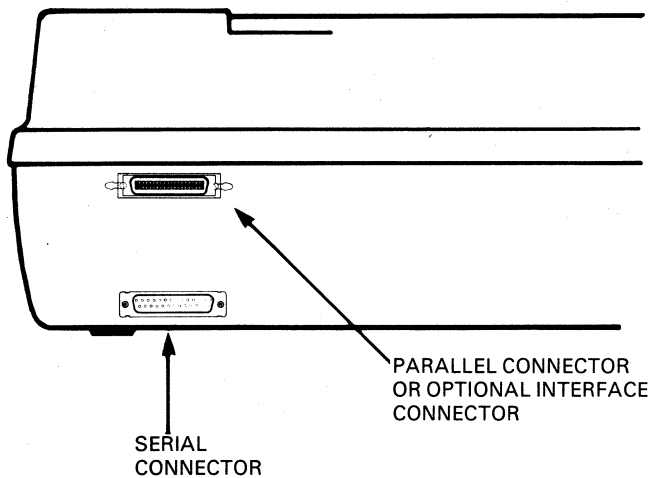

2222627-16

Figure 2-14. Data Cable Connectors

Section 3

Control Panel Operation

This section describes how to use the control panel to select printer features. The Model 880 operates in four modes to allow manual selection of printer features.

- Normal mode — for normal operation.
- Command mode — for manual setting of form length and vertical tabs.
- Menu mode — for printing the three following reports and menus:
 - Form Report and Menu — list fonts, character and line pitches, margins, form length, perforation-skip choices, and allow for new selections.
 - Configuration Report and Menu — list host-printer interfaces, language versions, baud rate and parity selections, miscellaneous configuration choices, and allow for new selections.
 - Character Set Report and Menu — list character set designations and invocations, and allow for new selections.
- Test mode — for troubleshooting printer problems (see Section 4).

3.1 NORMAL MODE

The six keys accessible through the window in the right side of the printhead door (Figure 3-1) perform the following functions:

- Aligning the form in 0.35 mm (1/72-inch) steps
- Moving the paper to the first line of the next form
- Moving the form to the next line
- Resetting printer errors
- Setting the printer on line and off line

3.2 COMMAND MODE

To put the printer in the command mode, lift the printhead door and press the **Command** key. The **Normal** indicator turns off, and the **Command** indicator turns on. The following functions can be performed from the control panel (Figure 5-2) while in command mode:

- Setting form length
- Setting the top of form
- Setting and clearing vertical tabs
- Advancing the form by lines to position new tabs
- Advancing the form to next vertical tab
- Printing the contents of receive buffer
- Clearing the contents of receive buffer
- Entering the menu mode and printing the form report

- Entering the menu mode and printing the configuration report
- Entering the menu mode and printing the character set report
- Entering the test mode and printing the status report
- Returning to normal mode

Normal Mode

Legends in white above and below panel keys are active in normal mode

Key sequence for entering normal mode:

Normal

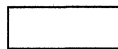

1.

Operations:

Normal printer operations

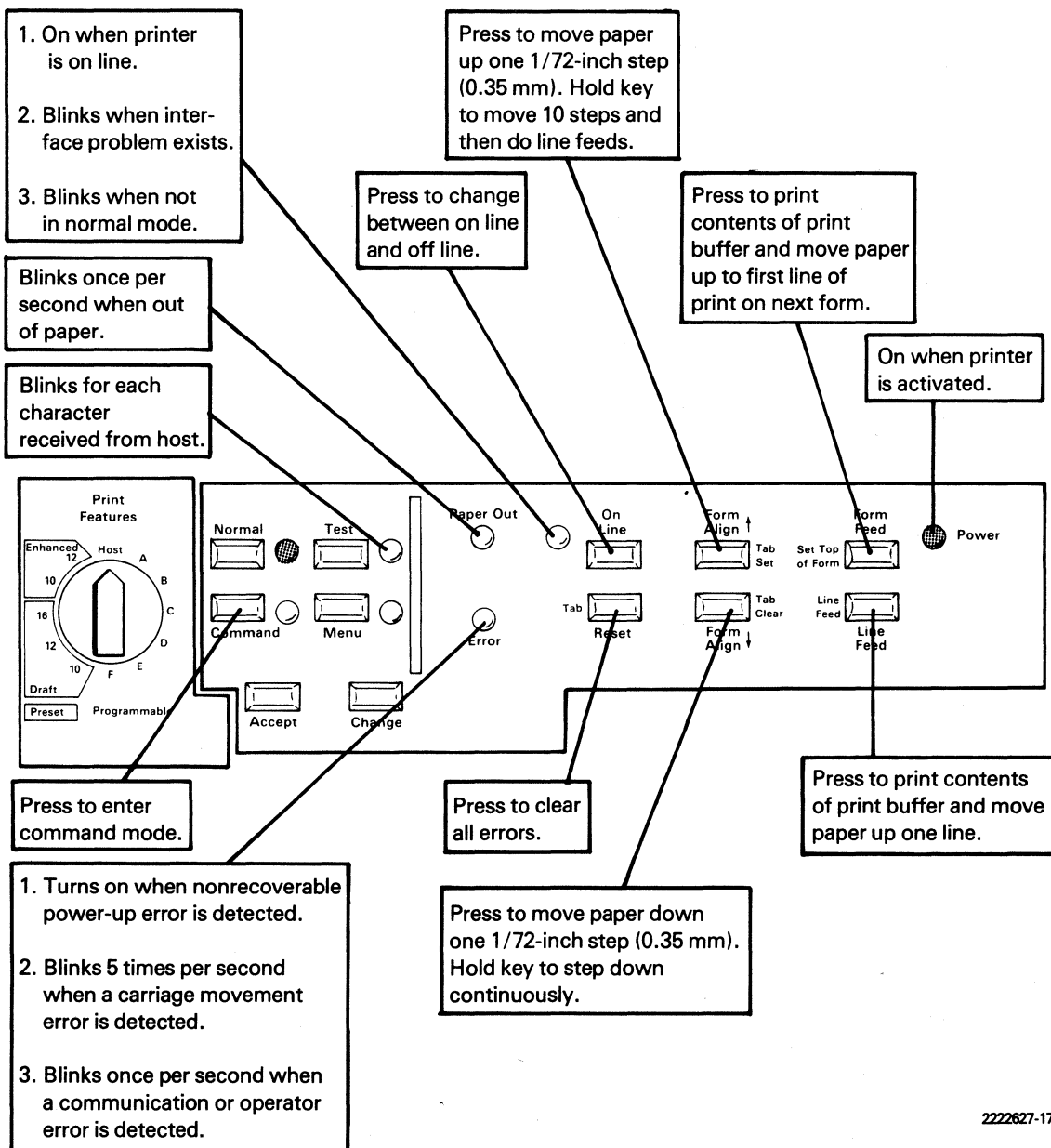

222627-17

Figure 3-1. Normal Mode

Command Mode

Legends in black beside keys are active in command mode.

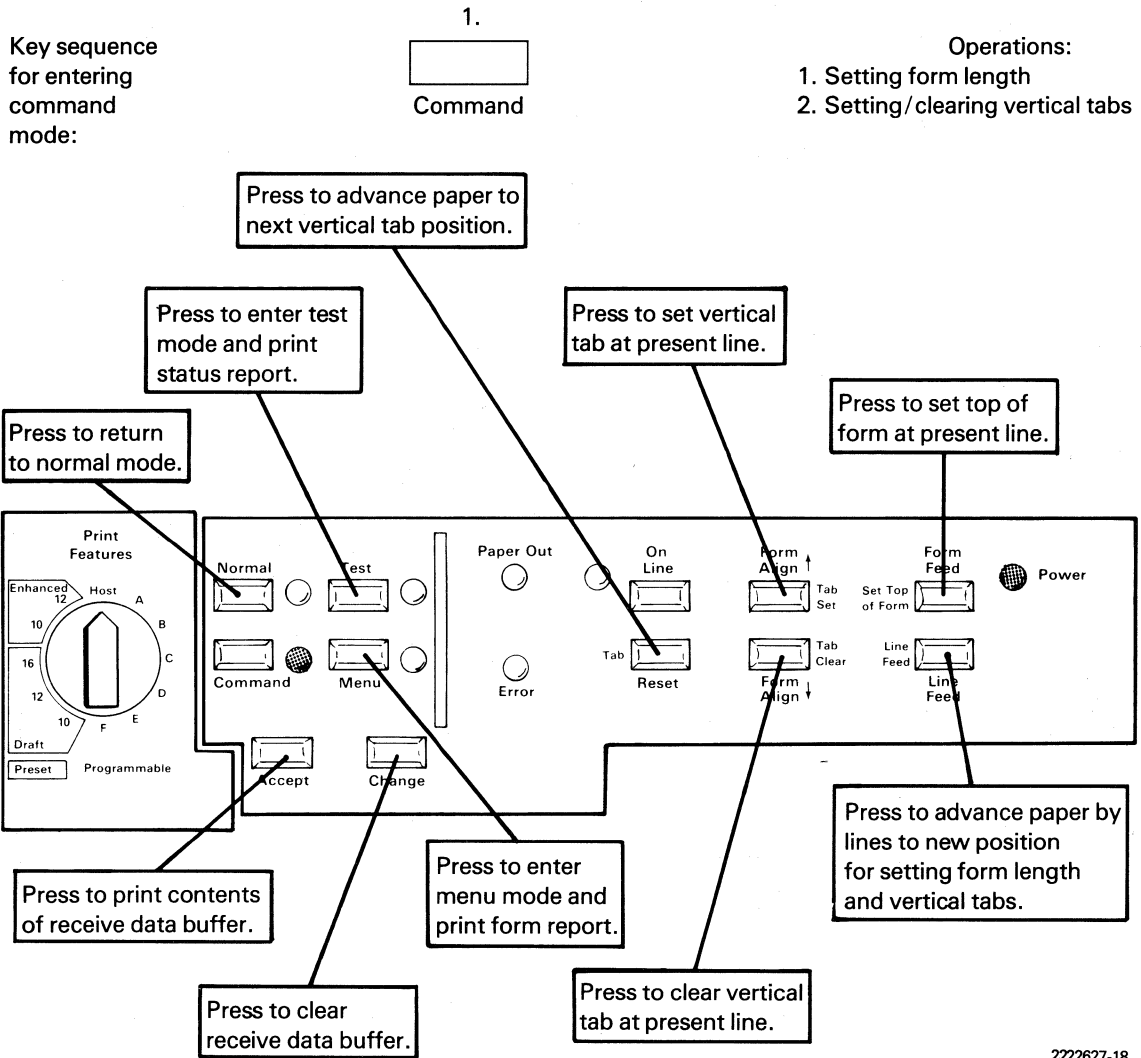

2222627-18

Figure 3-2. Command Mode

3.2.1 Setting Form Length and Top of Form

Use the following procedure to enter the command mode and set the form length from the control panel:

1. Open the printhead door (Figure 2-3).
2. Press the **Line Feed** key and (if necessary) the **Form Align** key to position the paper so that the printhead is where you want the first line of the form to be printed.
3. Press the **Command** key. The **Normal** indicator turns off and the **Command** indicator turns on.
4. Press the **Set Top of Form** key.
5. Press the **Line Feed** key to position the paper so that the printhead is where you want the first line of the next form to be printed.
6. Press the **Set Top of Form** key.
7. Return to normal mode by pressing the **Normal** key.
8. Check the new form length by pressing the **Form Feed** key.

NOTE

Returning to normal mode in the middle of the setting-form-length sequence will cause the printer to retain its previous form length and the **Error** indicator to blink. Press the **Reset** key to turn off the **Error** indicator.

By omitting steps 5 and 6 of the "Setting Form Length" procedure, you can move the top of form to the present line without changing form length.

3.2.2 Setting and Clearing Vertical Tabs

Use the following procedure to enter the command mode and set or clear vertical tabs from the control panel.

1. Open the printhead door.

2. Press the **Command** key. The **Normal** indicator turns off, and the **Command** indicator turns on.
3. Press the **Line Feed** key to position the paper for the desired tab position, or press the **Tab** key to move to the tab that is to be removed.
4. Press the **Tab Set** key to set a tab at the present line, or press the **Tab Clear** key to clear the tab at the present line.
5. Repeat steps 3 and 4 as needed.
6. Press the **Normal** key to return to the normal mode.
7. Press the **Form Feed** key to move to the top of form position.
8. Press the **Command** key to return to the command mode.
9. Press the **Tab** key to see if the new tab has been set or the old tab cleared.
10. Press the **Normal** key to return to the normal mode.

3.3 MENU MODE

The following functions can be performed from the control panel while in the menu mode.

- Changing font
- Changing characters-per-inch (cpi)
- Changing lines-per-inch (lpi)
- Selecting the perforation-skip (PERFSKIP) feature
- Checking host-software-controlled margins
- Printing the configuration report and menu
- Printing the character set report and menu
- Entering the test mode and printing the status report
- Returning to the normal mode

Menu Mode Form Report and Menu

Key sequence for entering menu mode and printing form report:

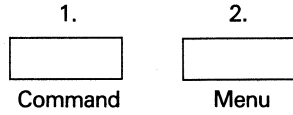

Operations:
 1. Changing font, cpi, lpi, and perfskip.
 2. Checking host-set margin

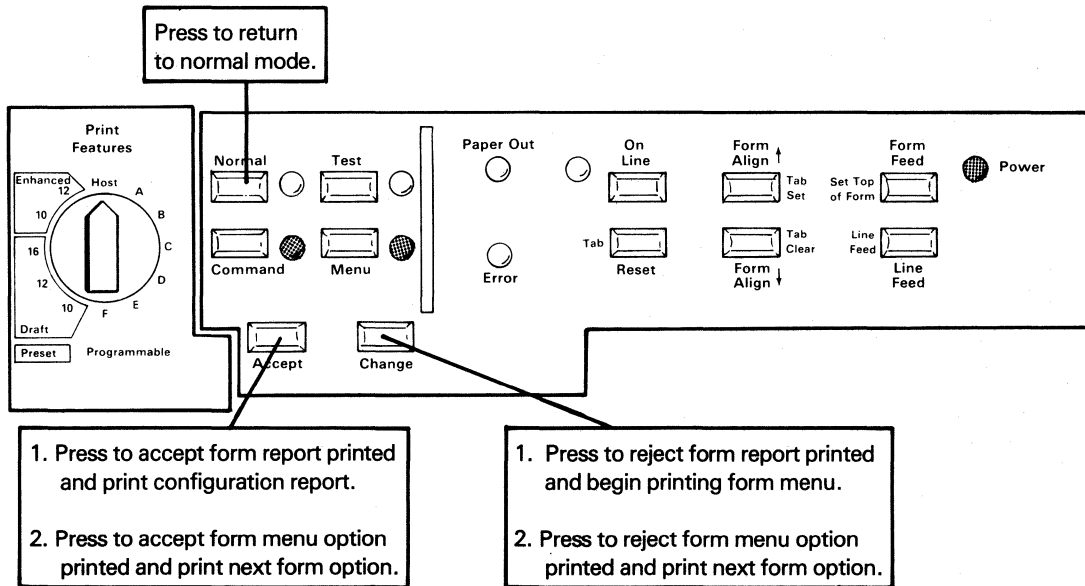

2222627-19

NOTE

Returning to normal mode in the middle of any option listing will cause the printer to retain the last selection printed.

Figure 3-3. Menu Mode (Form Report and Menu)

3.3.1 Form Report and Menu

Perform the following steps to enter the menu mode from the normal mode:

1. Open the printhead door.
2. Press the **Command** key. The **Normal** indicator turns off and the **Command** indicator turns on.

3. Press the **Menu** key. The **Menu** indicator turns on. The printer immediately prints a form report. The following example shows a typical form report.

FORM: PRTFEA = H; FONT = DRAFT; CPI = 10;
 LPI = 6 LM = 001; RM = 132; TM = 001;
 BM = 066; FL = 066; PERFSKIP = OFF

3.3.1.1 Form Features. The following print features are listed in the form report.

- **Print Features** (PRTFEA) switch position: **Host (H), Preset (P), A, B, C, D, E, or F.**
- Font: draft or enhanced.
- Characters per inch (CPI): 5, 6, 8-1/3 (8), 10, 12, or 16-2/3 (16) in draft font; 5, 6, 10, or 12 in enhanced font.
- Lines per inch (LPI): 3, 4, 6, or 8.
LPI = VMI (vertical motion index) when using variable line spacing.
- Left, right, top, and bottom margins (LM, RM, TM, BM): column and line numbers, based on currently selected horizontal and vertical pitch and margin-control software.
- Form length (FL): number of lines; based on currently selected vertical pitch and settings made from the control panel or from the host software.
- Perforation skip (PERFSKIP): on or off. The perfskip feature adds one line to the top margin and subtracts two lines from the bottom margin.

NOTE

Form length (FL) can be set from the control panel in the command mode. Margins can be set only by the host software. PRTFEA, FONT, CPI, LPI, and PERFSKIP can be set from the control panel in the menu mode.

3.3.1.2 Changing Form Features. Complete the following steps to change the FONT, CPI, LPI and PERFSKIP features:

1. After printing a form report as described in paragraph 3.3.1, "Form Report and Menu," press the **Change** key. The printer

begins to list the form menu by printing the currently selected font, as shown below. (Font will not be printed in the menu if the **Print Features** switch is in one of the **Preset** positions. See subsection 3.4, "PRINT FEATURES SWITCH", at the end of this section.)

FONT = DRAFT

2. Press the **Change** key. The printer now shows the next choice for font, as shown in this example.

FONT = DRAFT ENHANCED

3. Press the **Accept** key to select enhanced font. The printer now underlines your choice for font and lists the currently selected CPI (characters per inch) feature, as in this example. (CPI will not be printed if the **Print Features** switch is in one of the **Preset** positions. See "PRINT FEATURES SWITCH," at the end of this section.)

FONT = DRAFT ENHANCED
CPI = 10

4. Press the **Change** key. The printer now shows the next choice for CPI, which is 12 characters per inch, as in this example.

FONT = DRAFT ENHANCED
CPI = 10 12

5. Press the **Accept** key to select 12 CPI. (Or, you can keep pressing the **Change** key, and the other CPI choices will be listed until you press the **Accept** key to select one.) The printer now underlines your choice for CPI and lists the current LPI (lines per inch) selection, as shown in this example.

```

FONT = DRAFT  ENHANCED
CPI = 10  12
LPI = 6

```

6. Press the **Change** key. The printer now shows the next choice for LPI, which is 8 lines per inch, as shown below.

```

FONT = DRAFT  ENHANCED
CPI = 10  12
LPI = 6  8

```

7. Press the **Accept** key to select 8 LPI. (Or, you can keep pressing the **Change** key, and the other LPI choices will be listed until you press the **Accept** key to select one.) The printer now underlines your choice for LPI and lists the current state of the perforation skip feature, as shown in this example.

```

FONT = DRAFT  ENHANCED
CPI = 10  12
LPI = 6  8
PERFSKIP = OFF

```

8. Press the **Change** key. The printer now shows the other choice for the perforation skip feature, as in the following example.

```

FONT = DRAFT  ENHANCED
CPI = 10  12
LPI = 6  8
PERFSKIP = OFF  ON

```

9. Press the **Accept** key to turn on the perforation skip feature. The printer underlines your choice and prints a new form report based on the four selections you just made, as shown below.

```

FORM: PRTFEA = H; FONT = ENHANCED;
CPI = 12; LPI = 8
LM = 001; RM = 158; TM = 002; BM = 086;
FL = 088; PERFSKIP = ON

```

10. Press the **Normal** key to accept the new form report features and return to the normal mode or press the **Accept** key to accept the new form report and print the configuration report.

NOTE

Compare this form report with the original form report and notice that increasing the CPI from 10 to 12 changes the RM from 132 to 158. Increasing the LPI from 6 to 8 and activating the perforation-skip feature changes the BM from 66 to 86 and the FL from 66 to 88. Changing vertical and horizontal pitch causes the right and bottom margin numbers and the form length number to change as the printer maintains the same form size. Activating the perforation-skip feature changes the TM from 001 to 002 and the BM from 088 to 086. See Table 5-9 for more information regarding margins and line lengths.

3.3.1.3 Checking Host-Controlled Margins.

The left, right, top, and bottom margins (LM, RM, TM, and BM) are controlled by the host software. Printing the form report shows how the margins have been set. Print the form report and press the **Normal** key to return printer control to the host.

- Communication mode
- Baud rate
- Parity
- National language
- Miscellaneous features

3.3.2 Configuration Report and Menu

The following features can be selected on the control panel (Figure 3-4) from the configuration menu:

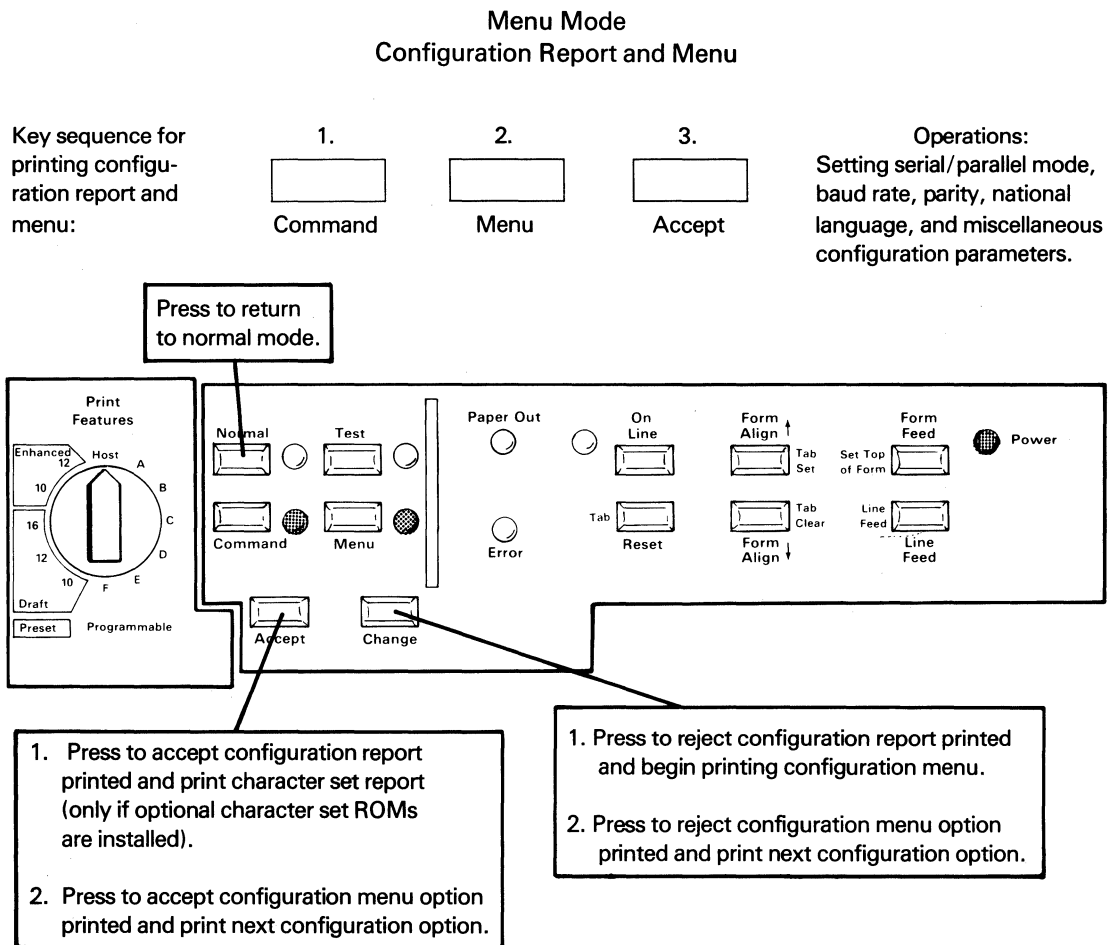

2222627-20

NOTE

Returning to normal mode in the middle of any option listing will cause the printer to retain the last selection printed.

Figure 3-4. Menu Mode (Configuration Report and Menu)

Follow these steps to print the configuration report:

1. Open the printhead door.
2. Press the **Command** key. The **Normal** indicator turns off and the **Command** indicator turns on.
3. Press the **Menu** key. The **Menu** indicator turns on. The printer immediately prints a form report.
4. Press the **Accept** key. The printer immediately prints a configuration report. The following example shows a typical configuration report.

CNFG: 14; 27; 36; 41; 81; 9B

3.3.2.1 Configuration Codes. The numbers listed in the configuration report are codes for the various configuration features. Configuration codes are listed in Tables 3-1 and 3-2. The numbers in the configuration report are for the following configuration features.

- 1st code: Communication mode
- 2nd code: Baud rate
- 3rd code: Parity
- 4th code: National language version
- 5th code: Miscellaneous features (More than one of these can be selected.)

3.3.2.2 Changing Configuration Codes. Follow this procedure to print the configuration menu and make new configuration selections:

1. After printing a configuration report as described in paragraph 3.3.2, "Configuration Report and Menu,"

press the **Change** key. The printer begins to list the configuration menu by printing the currently selected code for communication mode, as shown below.

COMM MODE = 14-ON

ON means the feature is selected (active). OFF means the feature is not selected (inactive).

2. Press the **Change** key. The printer turns off code 14 and shows the next communication mode code, which in this case is 15. (The codes appear in numerical order.)

COMM MODE = 14-ON 14-OFF 15-ON

3. Press the **Accept** key to select configuration code 15. (Or, you can keep pressing the **Change** key, and the other configuration code choices will be listed until you press the **Accept** key to select one.) The printer now underlines your choice for communication mode and lists the currently selected baud rate code, as shown below.

COMM MODE = 14-ON 14-OFF 15-ON
BAUD RATE = 27-ON

4. Press the **Change** key. The printer turns off code 27 and shows the next choice for baud rate, which is 28, as shown in the following example.

COMM MODE = 14-ON 14-OFF 15-ON
BAUD RATE = 27-ON 27-OFF 28-ON

5. Press the **Accept** key to select baud rate code 28. (Or, you can keep pressing the **Change** key, and the other baud rate code choices will be listed until you press the **Accept** key to select one.) The printer now underlines your choice for baud rate and lists the currently selected parity code, as shown below.

```
COMM MODE = 14-ON 14-OFF 15-ON
BAUD RATE = 27-ON 27-OFF 28-ON
PARITY = 36-ON
```

6. Press the **Change** key. The printer turns off code 36 and shows the next choice for parity selection, which is 37, as shown in the following example.

```
COMM MODE = 14-ON 14-OFF 15-ON
BAUD RATE = 27-ON 27-OFF 28-ON
PARITY = 36-ON 36-OFF 37-ON
```

7. Press the **Accept** key to select parity code 37. (Or, you can keep pressing the **Change** key, and the other parity choice codes will be listed until you press the **Accept** key to select one.) The printer now underlines your choice for parity and shows the currently selected national language code, as shown in the following example.

```
COMM MODE = 14-ON 14-OFF 15-ON
BAUD RATE = 27-ON 27-OFF 28-ON
PARITY = 36-ON 36-OFF 37-ON
LANGUAGE = 41-ON
```

8. Press the **Change** key. The printer turns off code 41 and shows the next choice for national language selection, which is 42, as shown below.

```
COMM MODE = 14-ON 14-OFF 15-ON
BAUD RATE = 27-ON 27-OFF 28-ON
PARITY = 36-ON 36-OFF 37-ON
LANGUAGE = 41-ON 41-OFF 42-ON
```

9. Press the **Accept** key to select national language code 42. (Or, you can keep pressing the **Change** key, and the other national language choice codes will be listed until you press the **Accept** key to select one.) The printer now underlines your choice for national language and begins to list the miscellaneous codes, as shown in the following example.

```
COMM MODE = 14-ON 14-OFF 15-ON
BAUD RATE = 27-ON 27-OFF 28-ON
PARITY = 36-ON 36-OFF 37-ON
LANGUAGE = 41-ON 41-OFF 42-ON
MISC = 81-ON
```

There are 14 different miscellaneous configuration codes. Any number of them can be selected.

10. Press the **Change** key. The printer now lists the first miscellaneous configuration code as "ON" or "OFF," depending on previous miscellaneous configuration code selections, as shown in the following example.

```
COMM MODE = 14-ON 14-OFF 15-ON
BAUD RATE = 27-ON 27-OFF 28-ON
PARITY = 36-ON 36-OFF 37-ON
LANGUAGE = 41-ON 41-OFF 42-ON
MISC = 81-ON 81 = OFF 83 = OFF
```

11. To select a code, press the **Accept** key when the code is printed as ON. To reject a code, press the **Accept** key when the code is printed as OFF. Press the **Change** key to change the code from ON to OFF or OFF to ON.

After you make the last miscellaneous configuration code selection, the printer prints the new configuration report showing your choices.

CNFG: 15; 28; 37; 42; XX; ...

12. Press the **Normal** key to return to normal mode or press the **Accept** key to print the character set report (if optional character sets are installed).

NOTE

Returning to normal mode in the middle of the configuration code selection procedure will cause the printer to retain all changes made up to that point.

Refer to Tables 3-1 and 3-2 for the Model 880 Printer configuration codes.

Table 3-1. Configuration Codes

Configuration Code*		Definition			
Communication Mode Selection (one only)	13	Full-duplex modem mode			
	14	Direct connection mode, pin 11 of serial interface ON for READY			
	<u>15</u>	Direct connection mode, pin 11 of serial interface OFF for READY			
	16	Current loop			
	17	Parallel interface			
	18	Communications controller interface (if installed)			
<hr/>					
Baud Rate (one only)	21	110 bits per second			
	22	200 bits per second			
	23	300 bits per second			
	24	600 bits per second			
	25	1200 bits per second			
	26	2400 bits per second			
	27	4800 bits per second			
	<u>28</u>	9600 bits per second			
	2A	19200 bits per second			
<hr/>					
Parity Selection (one only)	Data Bits	Parity Bits	Parity Format	Received Bits Checked?	
	31	7	1	odd	no
	32	7	1	even	no
	35	7	1	odd	yes
	36	7	1	even	yes
	<u>37</u>	7	1	mark	no
	38	7	1	space	no
	39	8	0	not used	no
	3A	8	1	odd	yes
	3B	8	1	even	yes
<hr/>					
National Language Version (one only)	41	United States			
	<u>42</u>	France			
	43	United Kingdom			
	44	Germany/Austria			
	45	Sweden/Finland			
	46	Denmark/Norway			
	47	Spain/Latin America			
	48	Switzerland			
	49	Canadian French			

*Underlined codes are the default codes.

Table 3-1. Configuration Codes (concluded)

Configuration Code*		Definition
Miscellaneous Codes (not limited)	<u>81</u>	Execute escape sequences
	<u>83</u>	Send DC1 when READY; DC3 when BUSY
	84	Do LF and CR on reception of LF
	85	Do LF and CR on reception of CR
	87	Print all control characters
	8A	Enable BUSY on pin 20 (DTR) of RS-232 connector
	8B	Do CR after LF, VT, DC2
	8C	Enable vertical raster graphics (see Chapter 6)
	93	Set absolute line length to 8 inches (see Table 3-2)
	99	Enable horizontal raster graphics (see Chapter 6)
	9A	SO selects expanded print for one line
	9B	Power-up on line
	<u>9C</u>	Select 256-byte input buffer

*Underlined codes are the default codes.

Table 3-2. Characters Per Line (CPL)

Standard Pitch				Double-Wide Pitch			
Code 93 ON		Code 93 OFF		Code 93 ON		Code 93 OFF	
CPI	CPL	CPI	CPL	CPI	CPL	CPI	CPL
10	80	10	132	5	40	5	66
12	96	12	158	6	48	6	79
16 $\frac{2}{3}$	132	16 $\frac{2}{3}$	220	8 $\frac{1}{3}$	66	8 $\frac{1}{3}$	110

3.3.3 Character Set Report and Menu

By printing the character set menu you can choose any of the optional character set ROMs you have installed. See Figure 3-5.

NOTE

If no optional character set ROM is installed, the printer will not print the character set report or character set menu.

Menu Mode Character Set Report and Menu

(The printer will access the character set menu only if an optional character set ROM is installed.)

Key sequence for printing character set report and menu: 1. Command 2. Menu 3. Accept 4. Accept Operations: Designating and invoking character sets.

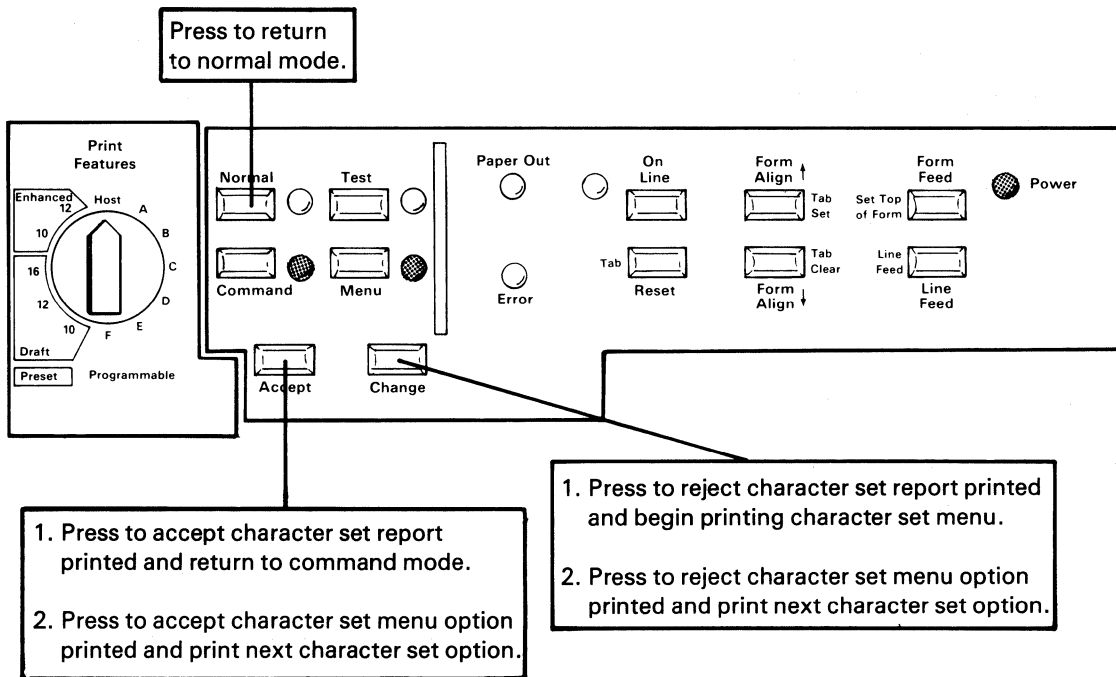

2222627-21

NOTE

Returning to normal mode in the middle of any feature listing will cause the printer to retain the last selection printed.

Figure 3-5. Menu Mode (Character Set Report and Menu)

Follow these steps to print the character set report:

1. Open the printhead door.
2. Press the **Command** key. The **Normal** indicator turns off and the **Command** indicator turns on.
3. Press the **Menu** key. The **Menu** indicator turns on. The printer immediately prints a form report.
4. Press the **Accept** key. The printer immediately prints a configuration report.
5. Press the **Accept** key again. The printer immediately prints a character set report.

The following example shows a typical character set report.

```
CHAR:  G0 = GOTHIC
        G1 = GOTHIC
        G2 = GOTHIC
        G3 = GOTHIC
        GL = G0; GR = G1
```

3.3.3.1 Character Set Designations. See Section 5 for an explanation of the G0, G1, G2, G3, GL, and GR character set designations.

3.3.3.2 Changing Character Set Selections. Follow these steps to make character set selections:

1. After you have printed a character set report as described in paragraph 3.3.3, "Character Set Report and Menu," press the **Change** key. The printer lists the currently selected character set for G0, as shown in the next example.

```
G0 = GOTHIC
```

2. Press the **Change** key. The printer now shows the next character set choice.

```
G0 = GOTHIC  OPTIONAL CHARACTER SET
```

3. Press the **Accept** key to select the optional character set for G0. (Or, if you have other character set ROMs installed, you can keep pressing the **Change** key, and the other character set choices will be listed until you press the **Accept** key to select one.) The printer now underlines your choice for G0 and lists the currently selected character set choice for G1, as shown in the following example.

```
G0 = GOTHIC  OPTIONAL CHARACTER SET
G1 = GOTHIC
```

4. Press the **Change** and **Accept** keys to make selections for G1 through G3 in the same manner you made the G0 character set selection.
5. After you make character set selections for G0 through G3, the printer will list the currently selected character set for GL, as shown below.

```
G0 = GOTHIC  OPTIONAL CHARACTER SET
G1 = GOTHIC
G2 = GOTHIC
G3 = GOTHIC  OPTIONAL CHARACTER SET
GL = G0
```

6. Press the **Change** key. The printer now lists the next character set choice for GL.

G0 = GOTHIC OPTIONAL CHARACTER SET
G1 = GOTHIC
G2 = GOTHIC
G3 = GOTHIC OPTIONAL CHARACTER SET
GL = G0 G1

7. Press the **Change** and **Accept** keys to make the desired character set selection for GL. The choices are G0, G1, G2, and G3.
8. After you make a character set selection for GL, the printer underlines your choice and lists the currently selected character set choice for GR.

G0 = GOTHIC OPTIONAL CHARACTER SET
G1 = GOTHIC
G2 = GOTHIC
G3 = GOTHIC OPTIONAL CHARACTER SET
GL = G0 G1 G2
GR = G1

9. Press the **Change** and **Accept** keys to make the desired character set selection for GR. The choices are G1, G2, and G3.

CHAR: G0 = OPTIONAL CHARACTER SET;
G1 = GOTHIC
G2 = GOTHIC;
G3 = OPTIONAL CHARACTER SET
GL = G2; GR = G3

10. After you make the character set selection for GR, the printer prints a new character set report based on your selections.

11. Press the **Accept** key to accept the new character set report. The printer returns to the command mode.

12. Press the **Normal** key to return to the normal mode.

3.4 PRINT FEATURES SWITCH

There are twelve positions of the **Print Features** switch (See Figure 3-6):

- **Host**—With the **Print Features** switch in the **Host** position, the host can control all printer features.
- **Preset**—With the **Print Features** switch in any of the five **Preset** positions, characters-per-inch and font (draft or enhanced) are determined by the switch position. Other form report features and character set designations can be programmed in the menu mode.
- **Programmable**—With the **Print Features** switch in any of the six **Programmable** positions (A through F), the active print features can be those selected from the form and character set menus while the **Print Features** switch was in that position. Six different combinations of font, characters-per-inch, lines-per-inch, form length, perforation-skip, vertical tabs, and character set designations can be programmed from the control panel.

NOTE

The configuration codes are the same for all positions of the **Print Features** switch.

3.4.1 Programmable Positions A - F

The following procedure is an example of how you can select printer features for one of the **Programmable** positions of the **Print Features** switch.

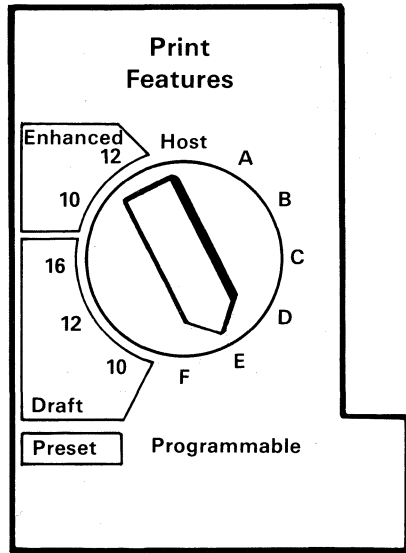

2222627-22

Figure 3-6. Programmable Position "E"

1. Open the printhead door.
2. Turn the **Print Features** switch to any **Programmable** position (A through F).
3. Follow the procedure in paragraph 3.2.1, "Setting Form Length," to select the form length for the **Programmable** position.
4. Follow the procedure in paragraph 3.2.2, "Setting and Clearing Vertical Tabs," to set vertical tabs for the **Programmable** position.
5. Follow the procedure in paragraph 3.3.1, "Form Report and Menu," to select font, characters per inch, lines per inch, and the perforation skip feature for the **Programmable** position.

6. Follow the procedure in paragraph 3.3.3, "Character Set Report and Menu," to select character set designations for the **Programmable** position.

3.4.2 Programmable Position Default Form Lengths

The **Print Features** switch positions A through F have different form length defaults, based on certain standard form lengths. They are listed in Table 3-3.

Table 3-3. Default Form Lengths

Programmable Position	Default Form Length	Type of Form
A	3.5 inches FL = 21 lines BM = line 021	Airline boarding pass
B	7.0 inches FL = 42 lines BM = line 042	Airline ticket
C	8.5 inches FL = 51 lines BM = line 051	11 x 8-1/2
D	11.0 inches FL = 66 lines BM = line 066	8-1/2 x 11 (Standard U.S.)
E	12.0 inches FL = 72 lines BM = line 072	8-1/2 x 12 (Standard international)
F	14.0 inches FL = 84 lines BM = line 084	8-1/2 x 14 (Standard legal)

3.5 DEFAULT FEATURES

Table 3-4 summarizes default values of the **Print Features** switch positions.

Pressing the **Menu**, **Accept**, and **Change** keys simultaneously will cause the printer to beep and return to default features for all positions of the **Print Features** switch and to the default configuration codes.

Table 3-4. Print Features Switch Defaults

Feature	Print Features Switch Position	
	Preset	Programmable
Font	As defined.	Draft
CPI	As defined.	10
LPI	6	6
LM	001	001
RM	132 for 10 CPI 158 for 12 CPI 220 for 16-2/3 CPI	132
TM	001	001
BM	66	See Table 3-3
FL	66	See Table 3-3
Perfskip	OFF	OFF

CAUTION

Before using this three-key technique to recall defaults, make sure that returning to configuration code defaults will not cause a loss of communication with the host.

Table 3-5. Default Configuration Codes

	Config. Code	Default
Communication Mode	14	ON
Baud Rate	27	ON
Parity	36	ON
National Language	41	ON
Miscellaneous	81	ON
	9B	ON
All Others		OFF

Table 3-6. Default Character Set Designations

G0 = G1 = G2 = G3 = GOTHIC
 GL = G0
 GR = G1

Section 4

Problem Analysis

This section describes the test mode and the status report. It also describes troubleshooting procedures to help you identify and correct any minor operating problems.

4.1 TEST MODE

The following functions can be performed from the control panel (Figure 4-1) while the printer is in the test mode.

- Printing the status report
- Printing the barberpole test

4.1.1 Status Report

Follow these steps to enter the test mode and print the status report:

1. Open the printhead door.
2. Press the **Command** key. The **Normal** indicator turns off and the **Command** indicator turns on.
3. Press the **Test** key. The **Test** indicator turns on. The printer immediately prints the status report.

The following example shows a sample status report.

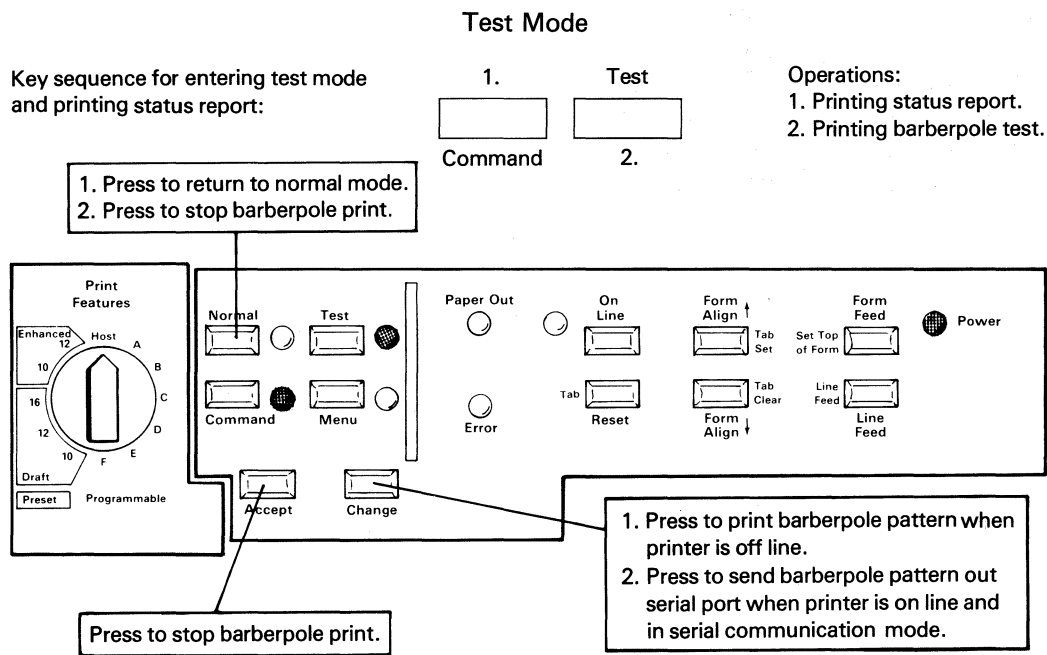

222627-23

Figure 4-1. Test Mode

ERROR: NONE

RCV BUFFER: 2K

ROM: XU310;0;GOTHIC;07;B;140C
XU303;ACS1;10;0000
XU304;ACS2;10;2F66
XU302;ACS3;10;2317
XU105;PCS1;08;A764

RS232: DSR(6)-ON; CTS(5)-ON; DCD(8)-ON

NOTE

The "RS232" line of the status report appears only if a serial printer/host interface has been selected in the configuration mode (code 13, 14, or 15 ON).

The example above reports:

- The printer reported no error code (NONE).
- 2K of RAM is configured for receive buffer use.
- A Gothic character-set ROM (revision level 07; identifier B used for character set selection with escape sequences; checksum value hexadecimal 140C) is installed on the Applications Controller (AC) board in socket XU310 (which is logical position 0 for escape sequence use).

NOTE

The identifier is called *z* and the logical position (0 - 4) is called *N* in the character set designation escape sequences (see Section 5).

- System ROMs are in locations XU302, XU303, and XU304 on the Applications Controller (AC) board and in location XU105 on the Printer Controller (PC) board.
- Lines 6, 5, and 8 of the 25-line RS-232 connector are **ON**.

NOTE

Lines 6, 5, and 8 of the 25-line RS-232 connector are biased on when no connection to the host exists. When the host connection is made these lines will indicate the conditions dictated by the host.

4.1.2 Error Codes

Table 4-1 summarizes error codes and corrective actions. If you need to call a service representative, any error codes that appear in the status report provide useful information for diagnosing printer problems.

Table 4-1. Error Codes

Status Code	Explanation/Action
02 Font ROM Fault	<p>Error in a font ROM. Compare ROMs in status report with option configuration label under printhead door. Faulty ROMs do not appear in status report. Printer works but will not use faulty font ROM.</p> <p>ACTION: Cycle power. If problem persists, call service representative.</p>
03 Nonvolatile RAM Fault	<p>Error in RAM that stores printer configuration. Cause may be battery failure, electrostatic discharge, or hardware failure. Printer configuration returns to default values.</p> <p>ACTION: Reconfigure printer and cycle power. If problem persists, call service representative.</p>
04 UART Fault	<p>Error in UART used by serial interface. Parallel interface not affected.</p> <p>ACTION: Cycle power. If problem persists, call service representative.</p>
05 Expansion RAM I Fault	<p>Error detected in RAM used for 4K expansion buffer. Standard buffer not affected.</p> <p>ACTION: Cycle power. If problem persists, call service representative.</p>
06 Communication Controller Fault	<p>Error detected in the optional communication controller. Standard serial and parallel interfaces not affected. Printer configuration returns to default values.</p> <p>ACTION: Cycle power and reconfigure printer. If problem persists, call service representative.</p>
08 Expansion RAM II Fault	<p>Error in RAM used for 16K expansion buffer. Standard buffer not affected.</p> <p>ACTION: Cycle power. If problem persists, call service representative.</p>
11* Carriage Fault	<p>Error indicator blinks rapidly. Something preventing carriage motion. If printhead has snagged the paper, printhead may be too close to paper.</p> <p>ACTION: Clear obstructions and adjust printhead if necessary. Press Reset key. If problem persists, call service representative.</p>
12* Paper Out	<p>Paper Out indicator will blink slowly. The printer is out of paper.</p> <p>ACTION: Reload paper and press Reset key.</p>
23 Input Buffer Overflow	<p>Host sent data after printer indicated it was busy.</p> <p>ACTION: Verify that printer is configured to indicate busy the way host expects. (See configuration codes 13 - 18.) Verify that cable makes correct connections to host. Press Reset key.</p>

*Error code will not print, but is transmitted in the transmitted status report.

Table 4-1. Error Codes (concluded)

Status Code	Explanation/Action
24 Parity Error	Occasional error may be caused by faulty grounds (see App. C). If more errors than good characters, problem may be incorrect baud rate or parity choice. ACTION: Verify ground connection between host and printer. Verify chassis-to-signal ground connection in printer (see App. C). Verify proper baud rate and parity selection. (See configuration codes 21 - 2A and 31 - 3B.)
29 Escape Sequence Error	Illegal sequence received or legal sequence with illegal argument. ACTION: Verify correct sequence being sent (see Section 6). Select configuration code 87 to verify correct sequence being received.
2A Escape Sequence Not Executed Print Features Switch Override	Host tried to change something that was selected by the Print Features switch. ACTION: Put switch in Host position, or correct illegal action by host.
2B Form Length Error	Illegal key was pressed while setting form length. Form length has not changed. ACTION: Refer to Section 3 and try again.
2C Character Set Not Installed	Host selected character set that is not installed. Status report shows which sets are installed. ACTION: Press Reset key. Select another character set.
30 – 3B Interface Loopback Errors	These errors are meaningful only when a special external test module is installed and an interface test is run. ACTION: If you ran the test by accident, ignore the errors and press RESET . Otherwise, call Service.

4.1.3 Barberpole Test

Follow these steps to enter the test mode and print the barberpole test:

1. With the printer in the Normal mode, take the printer off line by pressing the **On Line** key. The **On Line** indicator turns off.
2. Press the **Command** key. The **Normal** indicator turns off, and the **Command** indicator turns on.
3. Press the **Test** key. The **Test** indicator turns on. The printer immediately prints the status report.
4. Press the **Change** key. The printer begins to print the barberpole pattern. To stop the barberpole test, press the **Accept** key or the **Normal** key. (The barberpole test stops automatically after 190 lines.)

NOTE

If a current loop or an RS422 Interface option is installed, a parity error, code 24, may occur. This error does not affect printer operation.

Figure 4-2 shows a sample barberpole pattern.

4.2 TROUBLESHOOTING

Faulty printer operation can occur because of loose connections, an incorrect electrical ground, power spikes or electrical interference. Check that power and data cable connections to the terminal are

made as specified in Section 2, "INSTALLATION," and Appendix D, "POWER REQUIREMENTS AND GROUNDING."

If the **Error** indicator is blinking rapidly, check for jammed paper or anything that may be blocking the movement of the printhead. Press the **Reset** key. If the **Paper Out** indicator is blinking, see that the paper covers the paper-out switch. Press the **Reset** key.

If you are not sure of the cause of a problem, go into the test mode and print a status report. The error code may contain the explanation of the problem. If you are using the serial interface, check the "RS232" line of the status report for correct status of the DSR, DCD, and CTS lines. See Table 7-3.

Error codes 23, 24, 29, 2A, and 2B are communication errors. Go into the menu mode and print a configuration report (see Section 2). Are the correct configuration codes active? Check the "RS232" line of the status report.

If the printer is not successfully performing a particular task, ask yourself if it has ever done this kind of task for you before. If it has, try to determine what condition is different this time.

Use the power switch to turn the printer off and then back on. The printer will execute power-up self tests as described in Section 2. If the **On Line**, **Paper Out**, **Test**, **Menu**, and **Error** indicators fail to turn off, the problem will require a service call. (**On Line** comes back on if 9B is set.)

An optional loopback board (TI Part No. 2222661-0001) is available that will allow you to route the serial, on line barberpole output back to the printer. This is a means of checking the printer output drivers.

```
0123456789:;<=>?@ABCDEFGHIJKLMN OPQRSTUVWXYZ[\]^_`abcdefghijklmnop
123456789:;<=>?@ABCDEFGHIJKLMN OPQRSTUVWXYZ[\]^_`abcdefghijklmnopq
23456789:;<=>?@ABCDEFGHIJKLMN OPQRSTUVWXYZ[\]^_`abcdefghijklmnopqr
3456789:;<=>?@ABCDEFGHIJKLMN OPQRSTUVWXYZ[\]^_`abcdefghijklmnopqrs
456789:;<=>?@ABCDEFGHIJKLMN OPQRSTUVWXYZ[\]^_`abcdefghijklmnopqrst
56789:;<=>?@ABCDEFGHIJKLMN OPQRSTUVWXYZ[\]^_`abcdefghijklmnopqrstu
6789:;<=>?@ABCDEFGHIJKLMN OPQRSTUVWXYZ[\]^_`abcdefghijklmnopqrstuv
789:;<=>?@ABCDEFGHIJKLMN OPQRSTUVWXYZ[\]^_`abcdefghijklmnopqrstuvw
89:;<=>?@ABCDEFGHIJKLMN OPQRSTUVWXYZ[\]^_`abcdefghijklmnopqrstuvwx
9:;<=>?@ABCDEFGHIJKLMN OPQRSTUVWXYZ[\]^_`abcdefghijklmnopqrstuvwxy
:;<=>?@ABCDEFGHIJKLMN OPQRSTUVWXYZ[\]^_`abcdefghijklmnopqrstuvwxy
```

Figure 4-2. Barberpole Test

2222627-15

Table 4-2. Problem Analysis Procedures

Problem	Suggested Action
Error indicator stays on continuously.	Non-recoverable power-up error or fatal error during normal operation. Cycle power. If indicator stays on, call service representative.
Error indicator blinks slowly.	Operator error or communication error. Get status report and follow procedure in Table 4-1.
Error indicator blinks rapidly.	Carriage movement error. Clear obstruction and press Reset key.
Paper Out indicator blinks.	Load paper and then press Reset key.
Printhead does not print.	<ol style="list-style-type: none"> 1. Check ribbon condition and position. 2. Check Power indicator. 3. Check for normal operation: print form report. 4. Check data cable connections. 5. Cycle power. If problem persists, call service representative.
Error report indicates parity error.	Verify proper parity code choice. Press Reset key. If problem persists, call service representative.
Print is too light.	<ol style="list-style-type: none"> 1. Adjust printhead to the platen. 2. Change ribbon.
Print is too dark or smudged.	Adjust printhead away from platen.
On Line indicator blinks when in normal mode.	<ol style="list-style-type: none"> 1. Press Normal key. NOTE: With configuration code 14 or 15 active, On Line indicator will blink when the host has not raised the DSR signal (pin 6: serial interface). With configuration code 13 ON, On Line indicator will blink when CTS (pin 5), DSR (pin 6), or DCD (pin 8) has not been raised by the host system. 2. Check communication link.
Power indicator does not turn on.	<ol style="list-style-type: none"> 1. Check power cable connection. 2. Try another power outlet. If problem persists, call service representative.
Printer operation not as expected.	Verify that correct data is being sent by enabling configuration code 87 to cause special symbols to be printed for the received control characters shown in Appendix C.

Section 5

Software Commands

This section lists the Model 880 Printer control characters and escape sequences. It also describes how optional character sets can be used interchangeably.

5.1 CONTROL CHARACTERS

The Model 880 Printer interprets received data as ASCII characters. Table 5-1 gives the ASCII characters with their binary, decimal, and hexadecimal notations.

Table 5-1. U.S. ASCII Chart with Binary, Hexadecimal, and Decimal Codes

		Most Significant Bits							
		0	1	2	3	4	5	6	7
Hex Code	Binary Code	0000	0001	0010	0011	0100	0101	0110	0111
0	0000	NUL 0	DLE 16	SP 32	0 48	@ 64	P 80	\ 96	p 112
1	0001	SOH 1	DC1 17	! 33	1 49	A 65	Q 81	a 97	q 113
2	0010	STX 2	DC2 18	" 34	2 50	B 66	R 82	b 98	r 114
3	0011	ETX 3	DC3 19	# 35	3 51	C 67	S 83	c 99	s 115
4	0100	EOT 4	DC4 20	\$ 36	4 52	D 68	T 84	d 100	t 116
5	0101	ENQ 5	NAK 21	% 37	5 53	E 69	U 85	e 101	u 117
6	0110	ACK 6	SYN 22	& 38	6 54	F 70	V 86	f 102	v 118
7	0111	BEL 7	ETB 23	' 39	7 55	G 71	W 87	g 103	w 119
8	1000	BS 8	CAN 24	(40	8 56	H 72	X 88	h 104	x 120
9	1001	HT 9	EM 25) 41	9 57	I 73	Y 89	i 105	y 121
A	1010	LF 10	SUB 26	* 42	: 58	J 74	Z 90	j 106	z 122
B	1011	VT 11	ESC 27	+ 43	; 59	K 75	[91	k 107	{ 123
C	1100	FF 12	FS 28	, 44	< 60	L 76	\ 92	l 108	124
D	1101	CR 13	GS 29	- 45	= 61	M 77] 93	m 109	} 125
E	1110	SO 14	RS 30	. 46	> 62	N 78	^ 94	n 110	~ 126
F	1111	SI 15	US 31	/ 47	? 63	O 79	_ 95	o 111	DEL 127

Least Significant Bits

The control characters the Model 880 recognizes are listed in Table 5-2. Codes not listed are ignored.

Table 5-2. Control Character Operations

Control Char	Hex Code	Decimal Code	Description and Operation
NUL	00	0	Null. Terminates some tab set escape sequences.
EOT	04	4	End Of Transmission. Cnfg. code 99 ON: Current data line is odd horizontal raster graphics data; code 99 OFF: Not used.
ENQ	05	5	Enquiry. Cnfg. code 99 ON: Current line of data is even horizontal raster graphics data; code 99 OFF: Not used.
BEL	07	7	Bell. Makes short beep
BS	08	8	Backspace. Moves the logical print position back one space. No operation at left margin.
HT	09	9	Horizontal tab. Moves logical print position to next horizontal tab. Does CR and LF if no tabs are set between current position and right margin.
LF	0A	10	Line Feed. Cnfg. code 84 or 8B ON: Prints line, advances paper one line, logical CR to left margin; Codes 84 and 8B OFF: prints line, advances paper one line to next logical print position in the same column.
VT	0B	11	Vertical tab. Cnfg. code 8B ON: Adds auto CR. Code 8B OFF: Prints line, advances paper to next tab, same column.
FF	0C	12	Form feed. Prints line, advances paper to the top left margin of the next form.
CR	0D	13	Carriage return. Cnfg. code 85 ON: Prints line, does CR and LF; code 85 OFF: Prints line and does CR only.
SO	0E	14	Shift Out. Cnfg. code 9A ON: Expanded print line if first character in line; code 9A OFF: Select G1 character set as active GL character set.
SI	0F	15	Shift In. Select G0 character set as active GL character set.
DC1	11	17	Device Control 1. Cnfg. code 83 ON: Transmitted on serial interface to indicate "READY." (A received DC1 is ignored.) Cnfg code 83 OFF: Not used.
DC2	12	18	Device Control 2. Cnfg. code 8B ON: Tab to line of decimal number of next byte and do CR. Code 8B OFF: Tab to line of decimal number of next byte.

Table 5-2. Control Character Operations (concluded)

Control Char	Hex Code	Decimal Code	Description and Operation
DC3	13	19	Device Control 3. Cnfg. code 83 ON: Transmitted on serial interface to indicate BUSY.
DC4	14	20	Device Control 4. Tab to column of decimal number of next byte.
EM	19	25	End of Message. Next character printed is from G2 character set.
ESC	1B	27	Escape. Cnfg. code 81 OFF: Characters that follow are printed. Code 81 ON: Escape sequence commands are executed.
GS	1D	29	Group Select. Next character printed is from G3 character set.

5.2 SINGLE-PASS OVERSTRIKES

The Model 880 Printer does single-pass overstrikes to support single-pass underlines in draft and enhanced modes. The sequence, character-backspace-character, is recognized as a single-pass overstrike. The single-pass character dot pattern is formed by merging the dot patterns of the two characters.

5.3 ESCAPE SEQUENCES

The host can control printer operation through escape sequences. In the tables that follow, some escape sequences are given in two formats in which the line number, column number, or form length is represented as N or n .

The number N is entered as an ordinary decimal number. For example, if N represents the number 25 in an escape sequence, 25 is entered as a 2 and a 5. The ASCII characters 2 and 5 are sent to the printer.

The number n represents the decimal code for character n in Table 5-1. For example, if n represents the number 25 in an escape sequence, the

code for character 25 (EM) in the ASCII table is entered. The ASCII character EM is sent to the printer.

In the following escape sequence tables, the decimal codes for the escape sequence characters are given as examples.

NOTE

Do not enter spaces between the ASCII characters in the escape sequence commands. The spaces shown between the characters in these tables are for readability.

5.3.1 Form Length Escape Sequences

The form length is expressed as the number of lines in a form. The form length is set according to the currently enabled vertical pitch. Once the form length has been set, the actual size of the form remains the same until the form length is set differently, even though the vertical pitch may change. See Table 5-3.

Table 5-3. Form Length Escape Sequences

Escape Sequence Command	Definition of Command
ESC [<i>N</i> t 27 91 <i>N</i> 116 (0 < <i>N</i> < 113)	Enter form length to <i>N</i> .
ESC C <i>n</i> 27 67 <i>n</i> (0 < <i>n</i> < 113) or ESC 2 <i>n</i> 27 50 <i>n</i> (0 < <i>n</i> < 113)	Enter form length to <i>n</i> . Valid when 8C is OFF.
ESC P L 0 ESC \ 27 80 76 48 27 92 or ESC @ 27 64	Load default form: Font: draft CPI: 10 LPI: 6 Form length: default Margins: default Perfskip: OFF

5.3.2 Margin Control Escape Sequences

Changing vertical pitch does not change the top and bottom margins. See Table 5-5.

Changing horizontal pitch shifts the left margin to the nearest column of the new pitch. The right margin will shift in proportion to the change in pitch. See Table 5-4.

Table 5-4. Margins and Defaults

Margin	Definition	Default
LM	First print column on a line	Column 1
RM	Last print column on a line	Last column allowed by current character pitch and code 93
TM	First line that may contain data	PERFSKIP OFF: line 1 PERFSKIP ON: line 2
BM	Last line that may contain data	Determined by current form length PERFSKIP OFF: Last line of form PERFSKIP ON: Last line of form minus two

Table 5-5. Margin Control Escape Sequences

Escape Sequence Command	Definition of Command
ESC [<i>N</i> r 27 91 <i>N</i> 114	Enter TM at line <i>N</i> (1 < <i>N</i> < FL). If <i>N</i> = 0, then TM = default.
ESC [; <i>N</i> r 27 91 59 <i>N</i> 114	Enter BM at line <i>N</i> (1 < <i>N</i> < FL). If <i>N</i> = 0, then BM = default.
ESC [<i>N</i> 1 ; <i>N</i> 2 r 27 91 <i>N</i> 1 59 <i>N</i> 2 114	Enter TM and BM at lines <i>N</i> 1 and <i>N</i> 2. If <i>N</i> 1 = 0, then TM = default. If <i>N</i> 2 = 0, then BM = default.
ESC [<i>N</i> s 27 91 <i>N</i> 115	Enter LM at column <i>N</i> (1 < <i>N</i> < RM). If <i>N</i> = 0, then LM = default.
ESC [; <i>N</i> s 27 91 59 <i>N</i> 115	Enter RM margin at column <i>N</i> . If <i>N</i> = 0, then RM = default.
ESC [<i>N</i> 1 ; <i>N</i> 2 s 27 91 <i>N</i> 1 59 <i>N</i> 2 115	Enter LM at column <i>N</i> 1; RM at column <i>N</i> 2
ESC : <i>n</i> 27 58 <i>n</i>	Enter line width <i>n</i> . (< <i>n</i> < 127). (1 < <i>n</i> < 128 – 7-bit data; 1 < <i>n</i> < 221 – 8-bit data.)
ESC ; 27 59	Enter default line width (Max width allowed by current character pitch and code 93).

NOTE

A zero (0) entered for an *N*1 or *N*2 field in the margin control escape sequences sets the printer to the default value for that margin. (See Table 5-9)

5.3.3 Horizontal Tab Escape Sequences

Horizontal tabs are specified by the print column numbers. See Table 5-6.

Changing horizontal pitch changes the physical tab positions.

Changing between standard and expanded print does not affect the tab positions.

Table 5-6. Horizontal Tab Escape Sequences

Escape Sequence Command	Definition of Command
ESC [<i>N1</i> ; <i>N2</i> ; <i>NK</i> u 27 91 <i>N1</i> 59 <i>N2</i> 59 <i>NK</i> 117	Enter horizontal tab stops. Up to 16 tabs can be set by a single escape sequence. ($0 < N < 221$; $0 < K < 16$)
ESC 3 <i>n1</i> ... <i>nK</i> NUL 27 51 <i>n1</i> ... <i>nK</i> 0 ($1 < n < 128$; 7-bit data) ($1 < n < 221$; 8-bit data)	Enter horizontal tab stops. Clears previous tab stops. Valid when 8C is OFF.
ESC [<i>N</i> ' 27 91 <i>N</i> 96	Tab right to column <i>N</i> .
ESC H 27 72	Enter tab at present position.
ESC [<i>N</i> a 27 91 <i>N</i> 97	Tab right <i>N</i> columns.
ESC [2 g 27 91 50 103	Clear all horizontal tabs.
ESC [0 g 27 91 48 103	Clear tab at present position.

5.3.4 Vertical Tab Escape Sequences

Vertical tabs are identified by line number. See Table 5-7.

The actual positions of vertical tabs do not move when changing between single and double spacing.

Changing vertical pitch can change the physical positions of vertical tabs.

Table 5-7. Vertical Tab Escape Sequences

Escape Sequence Command	Definition of Command
ESC [<i>N1</i> ; <i>N2</i> ; <i>NK</i> v 27 91 <i>N1</i> 59 <i>N2</i> 59 <i>NK</i> 118	Enter vertical tab stops. Up to 16 tabs can be set by a single escape sequence. ($0 < N < 113$; $0 < K < 17$)
ESC 1 <i>n1</i> ... <i>nK</i> NUL 27 49 <i>n1</i> ... <i>nK</i> 0 ($0 < n < 113$)	Enter vertical tab stops. Clears previous tab stops.
ESC [<i>N</i> d 27 91 <i>N</i> 100	Tab to line <i>N</i> . Line <i>N</i> must be between the current line and the bottom margin.
ESC J 27 74	Enter tab at present position.
ESC [<i>N</i> e 27 91 <i>N</i> 101	Advance <i>N</i> lines. Move printhead <i>N</i> lines.
ESC [4 g 27 91 52 103	Clear all vertical tabs.
ESC [1 g 27 91 49 103	Clear vertical tab at present position.

5.3.5 Horizontal Pitch Escape Sequences

Character pitches of 5, 6, 8-1/3, 10, 12, and 16-2/3 characters-per-inch are available. Pitches 5, 6, and 8-1/3 are double-wide versions of standard pitches 10, 12, and 16-2/3. Characters at 10 and 12 cpi can be enhanced and so can characters at 5 and 6 cpi. See Table 5-8 and 5-9.

Table 5-8. Horizontal Pitch Escape Sequences

Escape Sequence Command	Definition of Command
ESC P C ESC \ 27 80 67 27 92	Select 10 cpi.
ESC 6 27 54	Select 10 cpi.
ESC P D ESC \ 27 80 68 27 92	Select 16 2/3 cpi.
ESC 7 27 55	Select 16 2/3 cpi.
ESC P I ESC \ 27 80 73 27 92	Select 5 cpi.
ESC P J ESC \ 27 80 74 27 92	Select 8 1/3 cpi.
ESC P K ESC \ 27 80 75 27 92	Select 12 cpi.
ESC P M ESC \ 27 80 77 27 92	Select double-wide pitch.
ESC P N ESC \ 27 80 78 27 92	Cancel double-wide pitch.
ESC P O ESC \ 27 80 79 27 92	Select enhanced characters.
ESC P P ESC \ 27 80 80 27 92	Cancel enhanced characters.
ESC b 27 98	Select bidirectional print.
ESC u 27 117	Cancel bidirectional print.

Table 5-9. Characters Per Line

Standard Pitch		Double-Wide Pitch	
Code 93 ON	Code 93 OFF	Code 93 ON	Code 93 OFF
CPI CPL	CPI CPL	CPI CPL	CPI CPL
10 80	10 132	5 40	5 66
12 96	12 158	6 48	6 79
16 132	16 220	8 66	8 110

5.3.6 Vertical Pitch Escape Sequences

You can select from 3, 4, 6, and 8 lines-per-inch. See Table 5-10.

Table 5-10. Vertical Pitch Escape Sequences

Escape Sequence Command	Definition of Command
ESC P A ESC \ 27 80 65 27 92	Select 6 lpi.
ESC 4 27 52	Select 6 lpi.
ESC 2 27 50	Select 6 lpi if 8C is ON.
ESC P B ESC \ 27 80 66 27 92	Select 3 lpi.
ESC P G ESC \ 27 80 71 27 92	Select 4 lpi.
ESC P H ESC \ 27 80 72 27 92	Select 8 lpi.
ESC 5 27 53	Select 8 lpi.
ESC 0 27 48	Select 8 lpi.
ESC P S ESC \ 27 80 83 27 92	Select vertical double spacing.
ESC P T ESC \ 27 80 84 27 92	Cancel vertical double spacing.

5.3.7 Printer Status Escape Sequences

Two escape sequences can be used to send information about the printer through the serial interface. See Table 5-11.

Table 5-11. Printer Status Escape Sequences

Escape Sequence Command	Definition of Command
ESC [c 27 91 99	Transmit current configuration report on the serial interface.
ESC [n 27 91 110	Transmit current status report on the serial interface.

A transmitted default configuration report appears in the following form:

[880;14;27;36;41c

where 14, 27, 36, and 41 are configuration codes (see Table 3-1). A transmitted status report appears in this form:

[880;AB;CD;EF;...;YZn

where AB, CD, etc. are error codes (see Table 4-1).

5.4 CHARACTER SET EXTENSION

The Model 880 Printer structure allows you to define the contents of the "in-use" character set table. The in-use table is the table of characters currently being printed. The contents of the in-use table can be entirely replaced by alternate character sets, or individual characters in the in-use table can be replaced by individual characters invoked from alternate character sets. There are four possible alternate character sets, called G0, G1, G2, and G3.

NOTE

Character set extension is possible only if optional character sets are installed on the Applications Controller board.

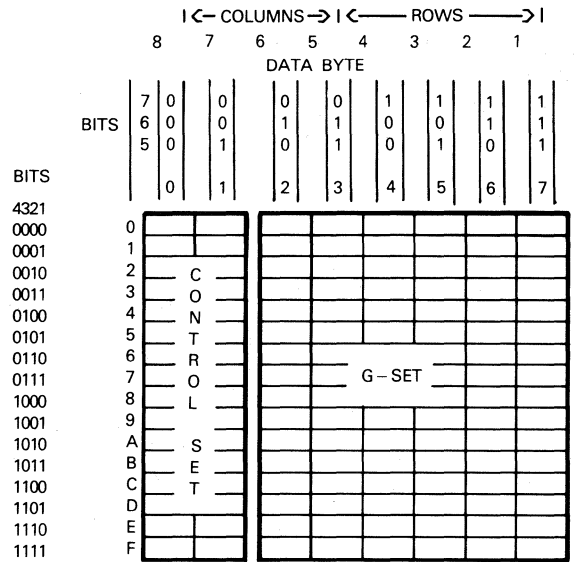

Figure 5-1. Seven-Bit Character Set Table

5.4.1 Seven-Bit Environment

Configuration codes 31, 32, 35, 36, 37, and 38 define a 7-bit environment. Seven data bits define a 128-character in-use table containing control characters in columns 0 and 1 and printable characters in columns 2 through 7. The area defined by columns 2 through 7 is called the GL (G-left) character set. The decimal equivalents of the binary numbers formed by bits 1 through 4 are the row numbers, and the decimal equivalents of the binary numbers formed by bits 5 through 7 are the column numbers. See Figure 5-1.

Alternate character sets G0, G1, G2, and G3 are available. The entire in-use set can be replaced by an alternate character set, or an individual in-use character can be replaced by a character from an alternate set. See Figure 5-2.

If optional character sets are installed on the Applications Controller board, control character SO invokes the G1 set into the in-use set (if configuration code 9A is OFF). Control character EM selects a character from the G2 set for the next entry. Control character GS selects a character from the G3 character set.

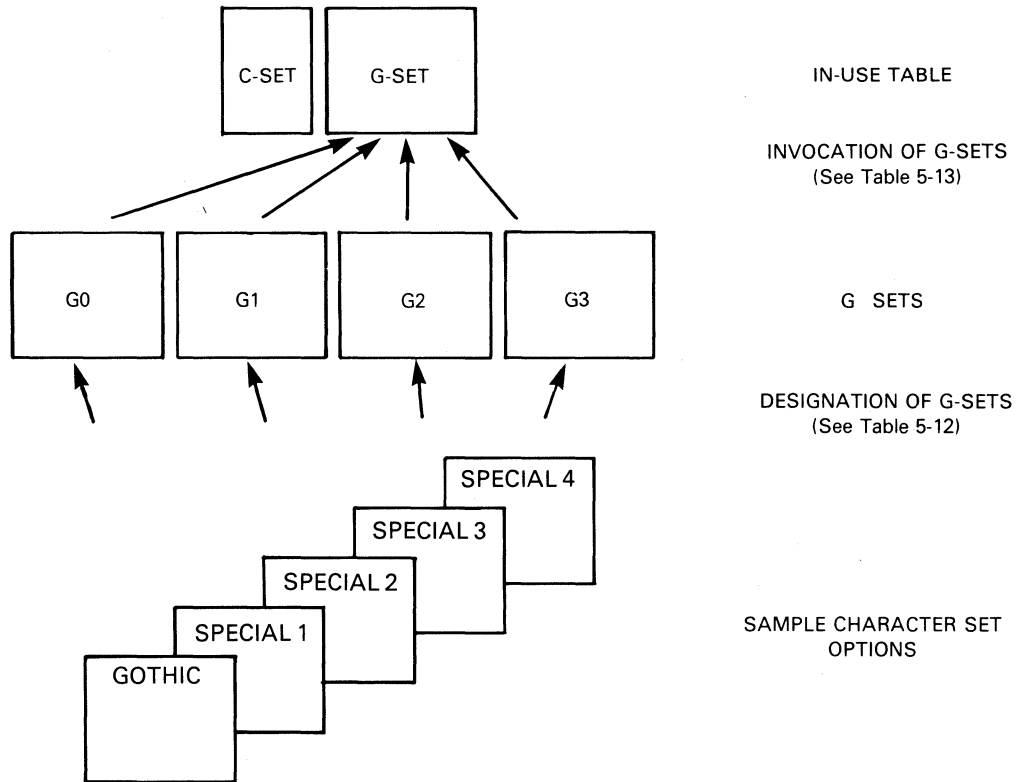

2222627-25

Figure 5-2. Seven-Bit Code Extension

A data byte received by the printer can be used either to locate a character in the in-use table or to change the contents of the table.

5.4.2 Eight-Bit Environment

Configuration codes 39, 3A, and 3B define an 8-bit environment. Eight bits define a 256-character table. Columns 0 and 1 and columns 8 and 9 are reserved for control characters. Columns 2 through 7 and columns 10 through 15 contain printable characters. The area defined by columns 2 through 7 is called the GL (G-left) character set. Columns 10 through 15 define the GR (G-right) character set. See Figure 5-3.

The Gothic character set is the default character set and consists of ASCII characters, United States version, or a national language version as determined by configuration. Other character sets are available as options and, when installed, can be selected as particular character sets (G0, G1, G2, or G3). See Figure 5-4.

Tables 5-12, 5-13, and 5-14 summarize the escape sequences and control characters for selection of character sets.

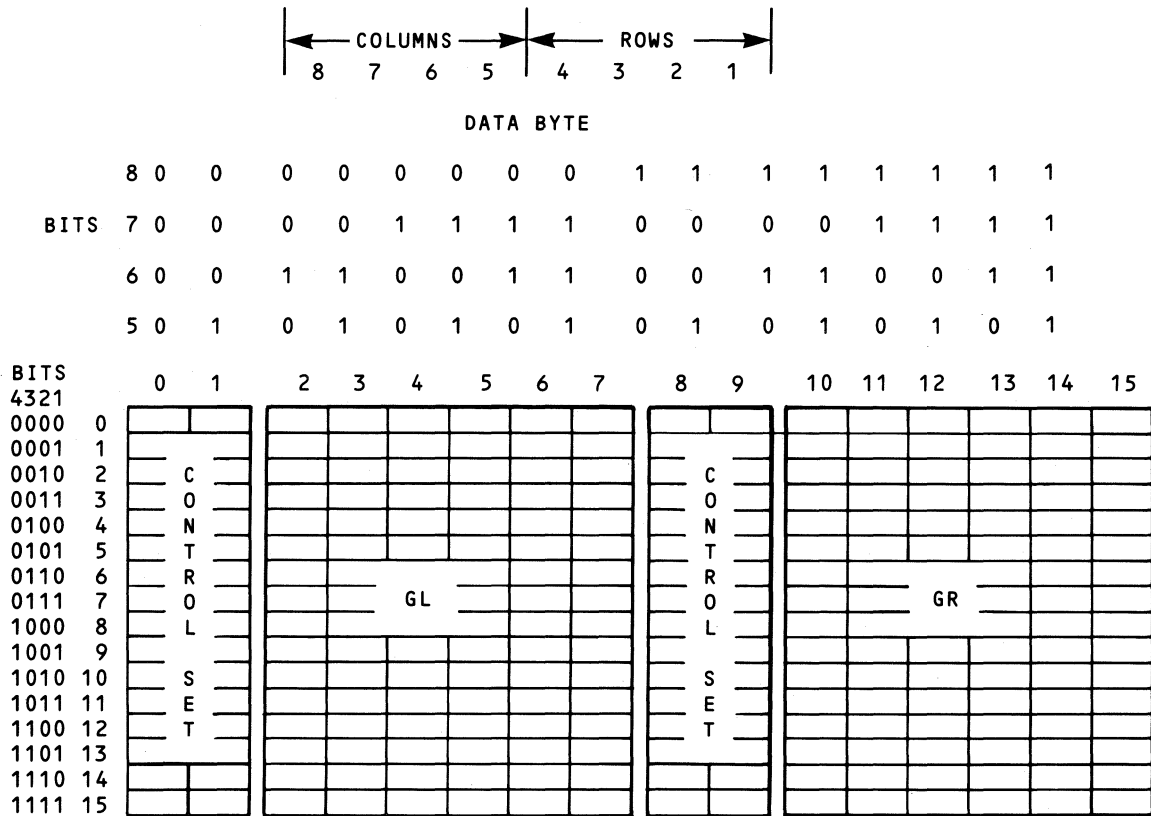
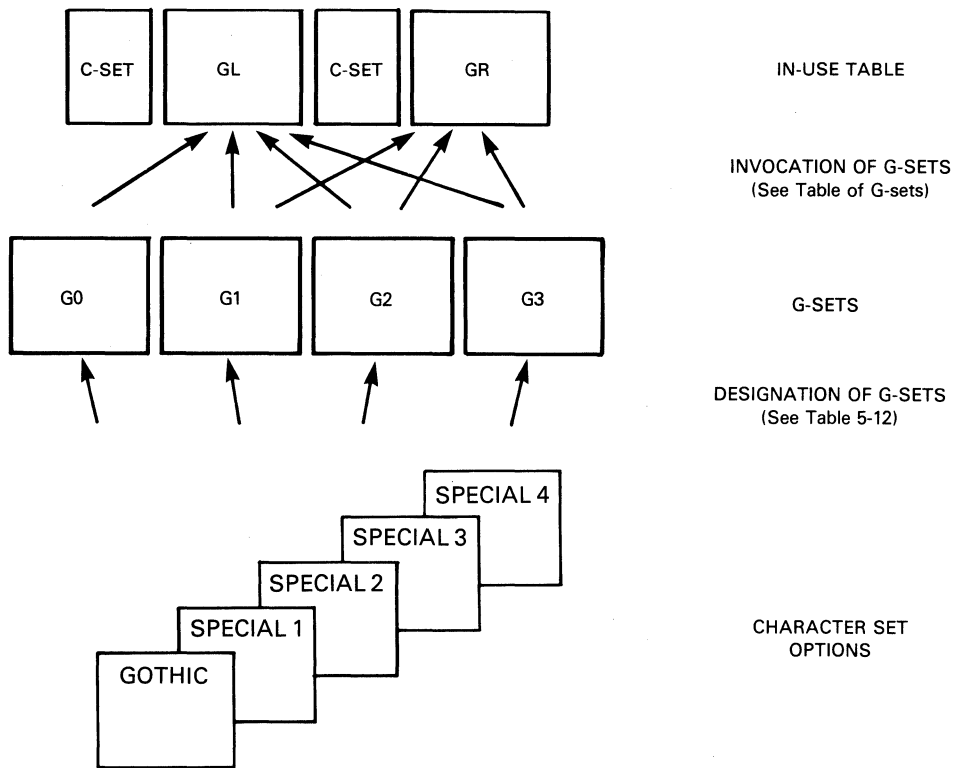

Figure 5-3. Eight-Bit Character Set Table

2222627-26



2222627-27

Figure 5-4. Eight-Bit Code Extension

Table 5-12. Escape Sequences for Character Set Designation

Escape Sequence Command	Definition of Command
ESC f N 27 102 N	Designate/invoke character set by socket; N = 0 to 4
ESC P N ESC \ 27 80 N 27 92	Designate/invoke character set by socket; N = 0 to 4
ESC (z 27 40 z	Designate G0 character set; z is the single character ROM identifier.
ESC) z 27 41 z	Designate G1 character set; z is the single character ROM identifier.
ESC * z 27 42 z	Designate G2 character set; z is the single character ROM identifier.
ESC + z 27 43 z	Designate G3 character set; z is the single character ROM identifier.

NOTE

The letter z is given as a single-letter ROM identifier in the ROM portion of the status report. N is given as a single-number (0-4) ROM position (see Table 5-15). For example, B is the Standard 880 character set escape sequence identifier; 0 is the logical position number for socket XU310. See Section 4 for a description of the status report.

Table 5-13. Escape Sequences For Character Set Invocation

Escape Sequence Command	Definition of Command
ESC k 27 107	Invoke G1 as GR.
ESC l 27 108	Invoke G2 as GR.
ESC m 27 109	Invoke G3 as GR.
ESC n 27 110	Invoke G2 as GL.
ESC o 27 111	Invoke G3 as GL.

The control characters SI and SO invoke G0 and G1, respectively, as GL. See Table 5-2.

Table 5-14. Special Character Selection Commands

Special Command	Definition of Command
EM y 25 y	Select G2 character designated by y. y = ASCII code for character selected.
GS y 29 y	Select G3 character designated by y. y = ASCII code for character selected.
SI 15	Select the current G0 character set as the active GL character set.
SO 14 (Code 9A OFF)	Select the current G1 character set as the active GL character set.

Table 5-15. Font ROM Positions

Logical Socket Number	AC Board Socket
0	XU310
1	XU309
2	XU308
3	XU307
4	XU306

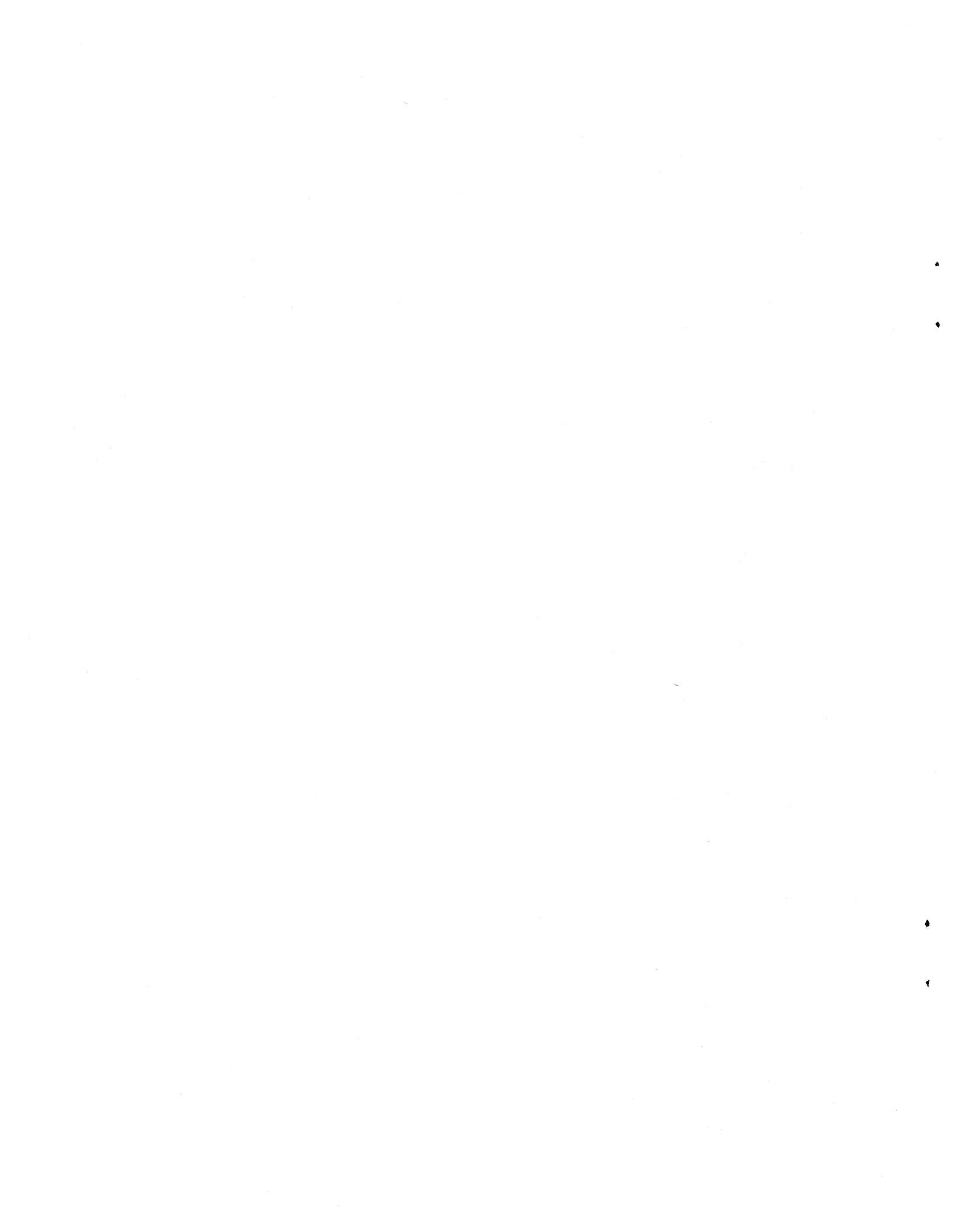

Section 6

Raster Graphics

This chapter describes how the Model 880 prints graphics data. Graphics data received from the host computer can be in either horizontal format (x-plot) or vertical format (y-plot).

CAUTION

Exercise caution when printing graphics. Continuous printing of any dot row must not exceed a printing duty cycle of 50% over a period of 6 minutes. Excessive printhead heating and accelerated printhead wear may result if this duty cycle is exceeded.

6.1 VERTICAL RASTER GRAPHICS

The vertical raster graphics format makes a map of the data received from the host to the printed dots.

The printer accepts either 7-bit or 8-bit data as determined by the configuration code. When code 39, 3A, or 3B is activated (ON), 8 data bits are received and are decoded to a map onto the paper as shown in Table 6-1.

Table 6-1. Vertical Raster Graphics Eight-Bit Data-to-Dot Map

Character Bit	Wire Number	Paper Dot
MSB 8	1	top
7	2	.
6	3	.
5	4	.
4	5	.
3	6	.
2	7	.
LSB 1	8	bottom

When configuration code 39, 3A, or 3B is not activated, 7 data bits are received and decoded to map onto the paper as shown in Table 6-2.

Table 6-2. Vertical Raster Graphics Seven-Bit Data-to-Dot Map

Character Bit	Wire Number	Paper Dot
MSB 7	1	top
6	2	.
5	3	.
4	4	.
3	5	.
2	6	.
LSB 1	7	bottom

Use the appropriate escape sequence (Table 6-3) to initiate each line of vertical graphics data. After the number of bytes specified in the escape

sequence has been processed as graphics data, normal character mode operations resume. See examples on following pages.

Table 6-3. Escape Sequences for Vertical Raster Graphics

Escape Sequence	Definition of Commands
ESC [<i>H</i> ; <i>B</i> ; <i>V</i> q 27 91 <i>H</i> 59 <i>B</i> 59 <i>V</i> 113	Set raster graphics. <i>H</i> = Horizontal dot density (60, 72, 120, or 144 dots per inch). <i>B</i> = Bytes of data to be received. <i>V</i> = Vertical line spacing (N/144 inch). N = 0 to 255. (Note 1)
ESC [<i>N</i> # q 27 91 <i>N</i> 35 113	Set line spacing to N/144-inch. N = 0 to 255. (Note 1)
Configuration code 8C allows the following TI 850/855-style sequences:	
ESC A <i>n</i> 27 65 <i>n</i>	Set line spacing to <i>n</i> /72-inch.
ESC K <i>n1 n2</i> 27 75 <i>n1 n2</i>	60 dots per inch (480 dots per line) <i>n1</i> = 1 to 255 bytes. <i>n2</i> = 0 bytes if <i>n2</i> is set to 0. <i>n2</i> = 256 bytes if <i>n2</i> is set to 1. <i>n2</i> = 512 bytes if <i>n2</i> is set to 2. <i>n2</i> = 768 bytes if <i>n2</i> is set to 3. <i>n1</i> + <i>n2</i> = number of graphics characters to be printed.
ESC L <i>n1 n2</i> 27 76 <i>n1 n2</i>	120 dots per inch (960 dots per line) <i>n</i> = 1 to 255 bytes <i>n2</i> = 0 bytes if <i>n2</i> is set to 0. <i>n2</i> = 256 bytes if <i>n2</i> is set to 1. <i>n2</i> = 512 bytes if <i>n2</i> is set to 2. <i>n2</i> = 768 bytes if <i>n2</i> is set to 3. <i>n2</i> = 1024 bytes if <i>n2</i> is set to 4. <i>n2</i> = 1280 bytes if <i>n2</i> is set to 5. <i>n2</i> = 1536 bytes if <i>n2</i> is set to 6. <i>n1</i> + <i>n2</i> = number of graphics characters to be printed.
ESC @ 27 64	Printer resets to default parameters
ESC 3 <i>n</i> 27 51 <i>n</i>	Set line spacing to <i>n</i> /216-inch. (Note 2)
ESC 2 27 50	Set line spacing to 6 lines/inch.

Note 1: Actual line spacing is rounded off to the closest 1/72 inch for 880 DP.

Note 2: Actual line spacing is rounded off the closest 1/72 inch for 880 DP and 1/144 inch for 880.

- H = Horizontal resolution of the printer.

The possible selections are:

60 dots per inch (default)
 72 dots per inch
 120 dots per inch
 144 dots per inch

If this parameter is omitted, the printer will default to the last horizontal resolution selected.

- B = Bytes of information to be received by the printer. This parameter can be set between 0 and 1900 for 13.2 inches at 144 dots per inch. If omitted, the value is 0. When the value is 0, the sequence is processed, but no raster-graphics data is actually printed.

- V = Variable line spacing parameter. The value of V is the number of 1/144 inches to feed the paper. Values of this parameter from 0 to 255 are valid. A value of 0 indicates that a line feed is not to be performed. This line feed has no relation to the executable LF control character.

The line feed spacing for graphics data can be specified to a number of half dot steps. When line spacing is not specified, the normal line spacing is used at the end of the line. An escape sequence is not needed to return to 6 or 8 lpi. Margins are ignored, and form length is not changed during graphics printing.

Example: Set the printer to receive 300 bytes of graphics data, and print it at 60 DPI (dots per inch) using a TI 850/855 - style sequence.

Sequence:	ESC	K	$n1$	$n2$
ASCII:	ESC	K	,	SOH
Decimal:	27	75	44	1
Hex:	1B	4B	2C	01

The 300 bytes following this sequence will be treated as graphics data.

Example: Set the printer to receive 480 bytes of graphics data, and print it at 60 DPI (dots per inch).

Sequence:	ESC	[H	;	B	;	V	q				
ASCII:	ESC	[60	;	480	;	16	71				
Decimal:	27	91	54	48	59	52	56	48	59	49	54	113
Hex:	1B	5B	36	30	3B	34	38	30	3B	31	36	71

The 480 bytes following this sequence will be treated as graphics data.

6.2 HORIZONTAL RASTER GRAPHICS

Horizontal graphics data can be printed at a density of 60 dots per inch, single density plot mode, or 120 dots per inch, double-density plot mode. The vertical density is 144 dots per inch.

6.2.1 Horizontal Raster Data Format/Single-Density Plot Mode

In single-density plot mode (Figure 6-1), a line of data containing the control character ENQ (>05, or hexadecimal 05), indicates that data from the left margin is horizontal raster data.

Bit 7 of all graphics data bytes must be set (1) for the data to be treated as graphics data; that is, valid characters for graphics data are from >40 to >7F. The low 6 bits are plot data.

The least significant bit (bit 1) is plotted *at the left* on the paper, and the remaining plot data bits (2, 3, 4, 5, and 6) are plotted, in order, to the right of bit 1.

A line feed (>0A) ends a row of data bits and the next byte of graphics data contains the first six

plot data bits to appear on the next row. When the printer has stored nine rows, it prints all of them and moves the paper up nine rows so that the tenth row of dots will just touch the ninth row.

When a row of raster data is longer than the line width, extra characters are discarded.

Line termination characters LF and FF cause the Model 880 Printer to start printing. Two or more consecutive line feeds, LF (>0A), cause the line to be printed and the paper to be moved at the current vertical pitch. A single line feed does not cause printing unless the last data received was for the ninth print row. A form feed, FF (>0C), causes the line to print and the paper to move to the top of the next form. The carriage return, CR (>0D), causes no printing or paper motion but allows the row of data to be changed by the next data line received.

When a data line does not contain the graphics data character, the remainder of the rows are filled with "blanks" (>40), and the line is printed. The printer is now back in the character print mode, and the paper is moved for the next line of the current vertical pitch.

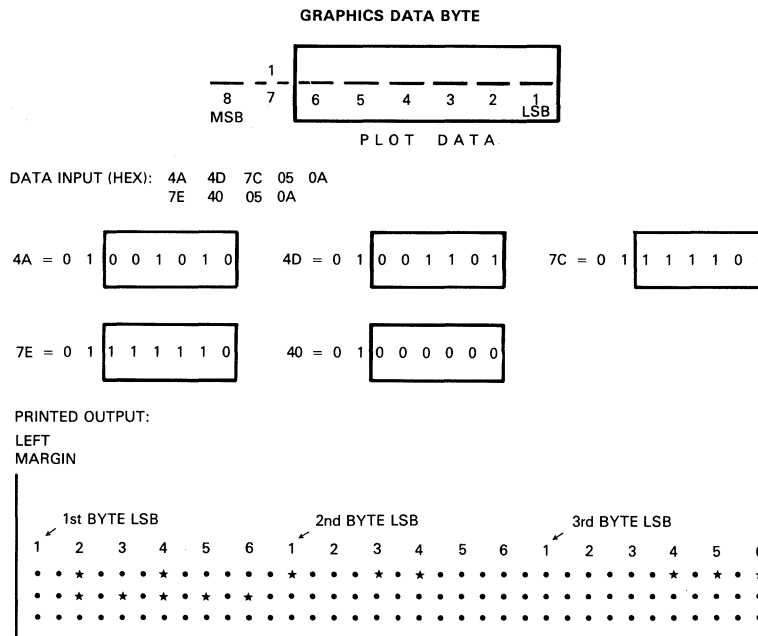
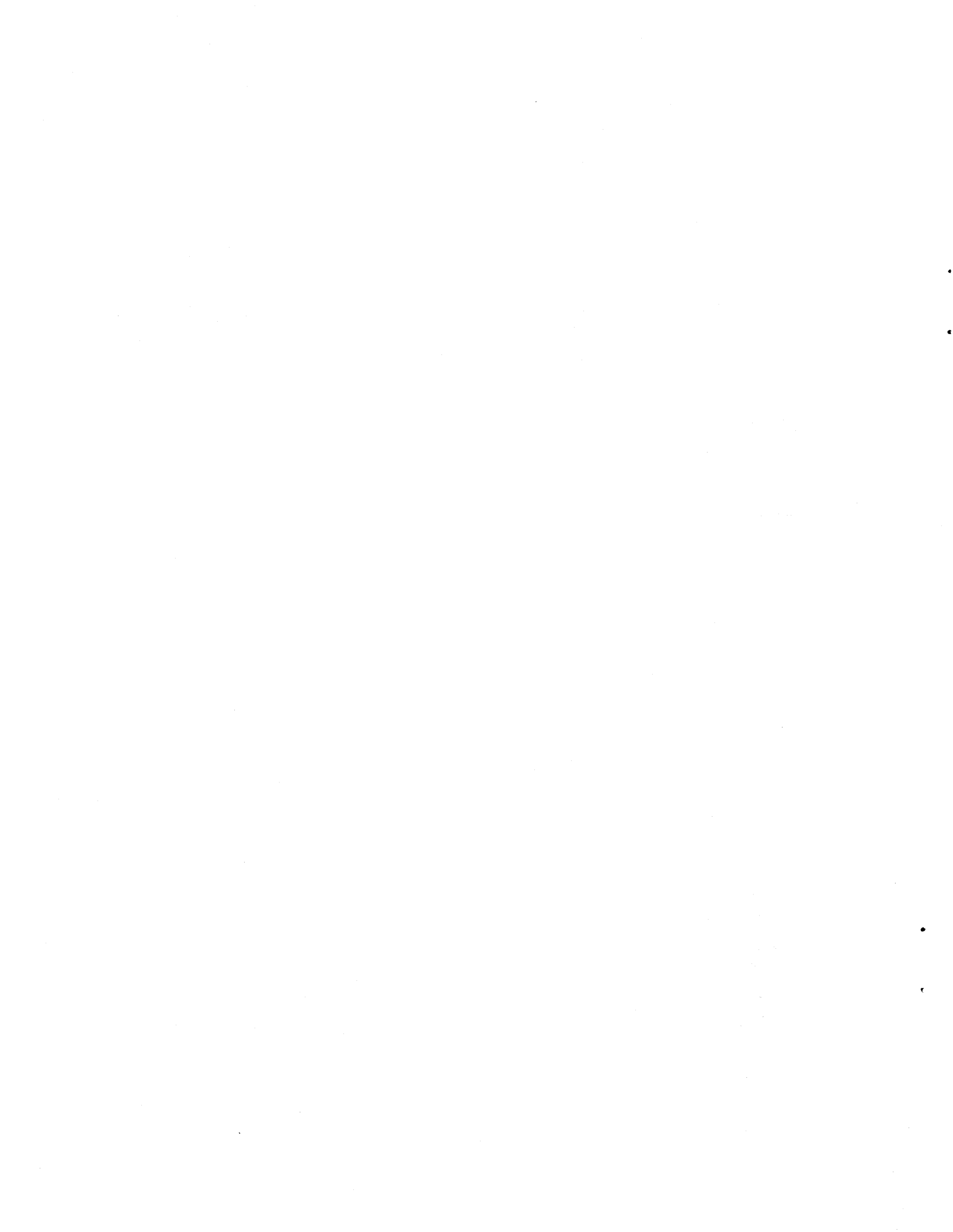

Figure 6-1. Horizontal Graphics - Single Density

2222627-28



Section 7

Communication Interfaces

This section describes the two methods of communication between the Model 880 and its host computer. The communication can be through either a serial or a parallel connection. You select the appropriate type of printer/host interface by choosing the configuration code while the printer is in the menu mode (see Section 3).

7.1 DATA INPUT BUFFER

All data received by the printer is temporarily stored in a first-in-first-out (FIFO) input buffer.

The operational size of the input buffer is determined by the physical size of the buffer installed (2K bytes standard, 4K bytes or 16K bytes optional) and the setting of configuration code 9C.

To prevent data from being lost when the printer receives data at a higher speed than the printer can print, the printer transmits "BUSY" to the host. The "BUSY" signal stops the host from sending data. The printer transmits "READY" to the host when more data can be put into the buffer. The buffer sizes and READY/BUSY points are shown in Table 7-1.

Table 7-1. Buffer Size and READY/BUSY Points

	Config. Code 9C – ON	Code 9C – OFF		
		2K bytes	4K bytes	16K bytes
Buffer size, serial and parallel I/F	256 characters	2048 characters	4096 characters	16 384 characters
BUSY point, serial I/F only	249 characters	1792 characters	3840 characters	16 128 characters
BUSY point, parallel I/F only	256 characters	2048 characters	4096 characters	16 384 characters
READY point, serial and parallel I/F	121 characters	1280 characters	2816 characters	15 104 characters

The READY/BUSY signal sent to the host is determined by the interface selected and the setting of configuration code 83. The READY/BUSY signals are listed in Table 7-2.

Table 7-2. READY/BUSY Signals

Configuration Codes Selected	BUSY or READY	Serial Connector		Parallel Connector
		Pin 11 (Pin 20 if 8A = ON)	Pin 2 Transmit	Pin 11
13 ON; 83 OFF	BUSY	Low	Not used	Not used
13 ON; 83 OFF	READY	High	Not used	Not used
13 ON; 83 ON	BUSY	Low	DC3	Not used
13 ON; 83 ON	READY	High	DC1	Not used
14 ON; 83 OFF	BUSY	Low	Not used	Not used
14 ON; 83 OFF	READY	High	Not used	Not used
14 ON; 83 ON	BUSY	Low	DC3	Not used
14 ON; 83 ON	READY	High	DC1	Not used
15 ON; 83 OFF	BUSY	High	Not used	Not used
15 ON; 83 OFF	READY	Low	Not used	Not used
15 ON; 83 ON	BUSY	High	DC3	Not used
15 ON; 83 ON	READY	Low	DC1	Not used
16 ON; 83 OFF	BUSY	Low	Not used	Not used
16 ON; 83 OFF	READY	High	Not used	Not used
16 ON; 83 ON	BUSY	Low	DC3	Not used
16 ON; 83 ON	READY	High	DC1	Not used
17 ON; 83 OFF	BUSY	Not used	Not used	5 Vdc
17 ON; 83 OFF	READY	Not used	Not used	0 Vdc
17 ON; 83 ON	BUSY	Not used	Not used	5 Vdc
17 ON; 83 ON	READY	Not used	Not used	0 Vdc

7.2 SERIAL INTERFACE

The serial link is made through the 25-pin connector socket at the rear of the printer. The serial link is asynchronous and operates in a modem mode or one of two direct-connect modes as determined by configuration parameters 13, 14, and 15.

7.2.1 Data Structure

A received character includes 1 start bit, 7 or 8 data bits, 1 or no parity bit, and at least 1 stop bit for all reception rates. Determine the data and parity bits by selecting the appropriate configuration code from Table 3-1. Figures 7-1 and 7-2 show 7- and 8-bit data structures.

7.2.2 Serial Connector Pin Listing

The pin numbers for the serial interface are shown in Table 7-3.

7.3 PARALLEL INTERFACE

The parallel interface can be used in either the STROBE/ACK/BUSY protocol or the DEMAND/STROBE protocol. The parallel connection allows the printer to receive data, but not to send data.

7.3.1 Parallel Connector Pin Listing

The parallel interface connector is a 36-pin connector. The parallel connector socket is the upper of the two connectors on the rear of the printer. The pin numbers for the parallel interface are shown in Table 7-4.

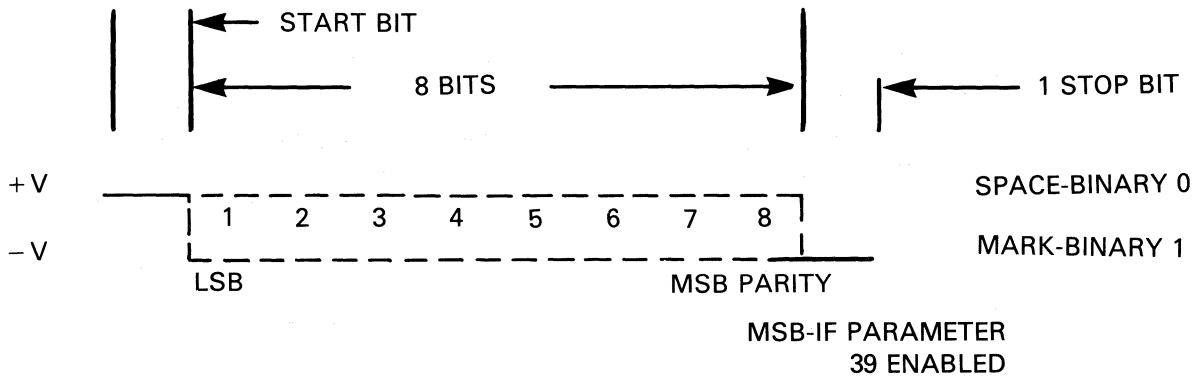

Figure 7-1. Seven-Bit Serial Data Structure

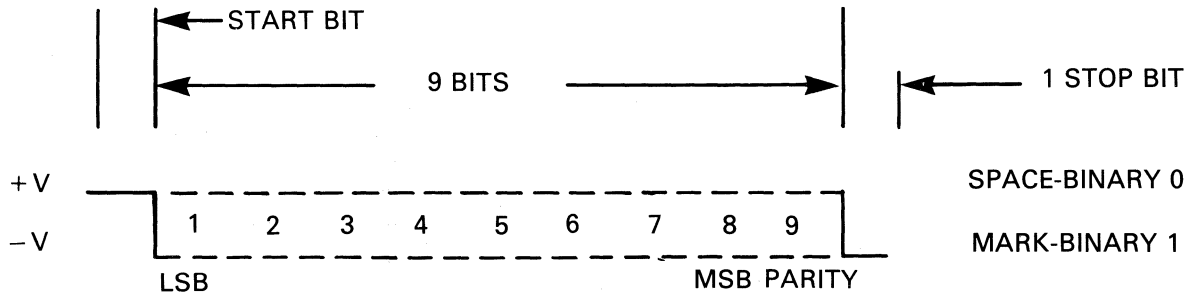

Figure 7-2. Eight-Bit Serial Data Structure

2222627-30

2222627-31

Table 7-3. Serial Interface Signals

Pin No.	Source	Signal	RS232	CCITT	Function
1	–	PROTECTIVE GND	AA	101	Connected to earth ground.
2	P	TRANSMITTED DATA	BA	103	Conveys data to host.
3	H	RECEIVED DATA	BB	104	Conveys data to printer.
4	P	REQUEST TO SEND	CA	105	CNFG.CODE 14 or 15 ON: ON at all times. CNFG.CODE 13 ON: ON when printer on line; OFF when printer is off line.
5	H	*CLEAR TO SEND	CB	106	CNFG.CODE 14 or 15 ON: Not used. CNFG.CODE 13 ON: Must be ON to send data.
6	H	*DATA SET READY	CC	107	Must be ON to send/receive data.
7	–	SIGNAL GND	AB	102	Ground reference for interface signals.
8	H	*RECEIVED LINE SIGNAL DETECTOR	CF	109	CNFG.CODE 14 or 15 ON: Not used. CNFG.CODE 13 ON: Must be on to receive data.
9	P	+ VOLTS			+ 12 Vdc Input bias; tied to 1K series resistor.
10	P	– VOLTS			– 12 Vdc Input bias; tied to 1K series resistor.
11	P	READY/BUSY			Signals READY/BUSY status to host; READY/ON when CNFG.CODE 13, 14, or 16 enabled; READY/OFF when CNFG.CODE 15 enabled.
20	P	DATA TERMINAL READY	CD	108.2	CNFG.CODE 14 or 15 ON: ON all the time; CNFG.CODE 13 ON: ON when on line; OFF when off line. Same as READY/BUSY when CNFG.CODE 8A ON.

P = Printer

H = Host

Pins 12 – 19 and 21 – 25 are not used.

* Biased on with no connection.

Table 7-4. Parallel Interface Signals

Signal Pin	Return Pin	Source	Signal	Description
1	19	H	STROBE-	Positive-going edge latches the 8 data bits and turns BUSY on (DEMAND off).
2	20	H	DATA1	Eight high-active parallel inputs. DATA1 is the least significant bit. DATA8 is the most significant bit. DATA8 is used only when configuration code 39, 3B, or 3A is enabled.
3	21	H	DATA2	
4	22	H	DATA3	
5	23	H	DATA4	
6	24	H	DATA5	
7	25	H	DATA6	
8	26	H	DATA7	
9	27	H	DATA8	
10	28	P	ACK -	Normally high. Pulsed low when: 1. Printer is ready to receive data. 2. Printer is placed on line.
11	29	P	BUSY	When printer cannot receive data, it signals BUSY. Possible reasons: 1. Printer is off line. 2. Data not yet acknowledged. 3. Data buffer at BUSY limit. 4. Printer in Command mode. 5. Printer out of paper. 6. Mechanical fault.
12		P	PE (Paper Empty)	High when paper-out switch is activated.
13		P	SLCT	High when printer is on line.
16			SIGNAL GROUND	Tied to dc power supply ground. Reference ground for all interface signals.
17			CHASSIS GROUND	Tied to earth ground.
18			+ 5 Vdc	For interface circuits. Should be limited to 100 mA.
31	30	H	INIT -	Normally high. When pulsed low, printer resets and does power-up diagnostics and goes on line if configuration code 9B is ON.

P = Printer
H = Host

Table 7-4. Parallel Interface Signals (concluded)

Signal Pin	Return Pin	Source	Signal	Description
32		P	FAULT –	Goes low to indicate carriage jam or paper-out condition.
33		SIGNAL GROUND		
34		H/P	I/F VERIFY IN	To verify proper cable connection (connected to pin 35).
35		H/P	I/F VERIFY OUT	To verify proper cable connection (connected to pin 34).
36		*P	DEMAND (SELECT IN –)	Inverse of BUSY. Set to 0 Vdc by host to print.

P = Printer

H = Host

*Motherboard jumper E16-E17 must be installed for this signal to be active.

The parallel interface uses TTL voltages on inputs and outputs. Figure 7-3 shows electrical characteristics.

7.3.2 Parallel Data Timing

Figure 7-4 shows the timing of typical parallel data communication.

Figure 7-5 shows the on line and off line timing of a Model 880 Printer with parallel interface.

7.3.3 Paper-Out and Mechanism Faults

FAULT – and PE are status lines which can be set at any time relative to the input signals. FAULT – is set low to indicate carriage fault or paper out; FAULT – is set high to indicate that the faults are repaired. PE is set high to indicate paper out; PE is set low to indicate that paper has been loaded again, and the Reset key has been pressed to clear the error.

After either FAULT – or PE is set to indicate a fault, BUSY is set high (DEMAND is set low). If a STROBE – occurs while BUSY is high (DEMAND is low), the character is held in the interface and is not printed, and ACK – is not sent until the fault is cleared.

7.3.4 Sequence to Initialize the Printer

The sequence to initialize the printer is a power-up reset generated by the host system. As shown in Figure 7-6, when the INIT – line is pulsed low, the printer stops what it is doing, takes itself off line (SLCT low) if it was on line, and runs through the power-up routines. At the end of the power-up routines, the printer goes on line (SLCT high) if configuration code 9B is set ON.

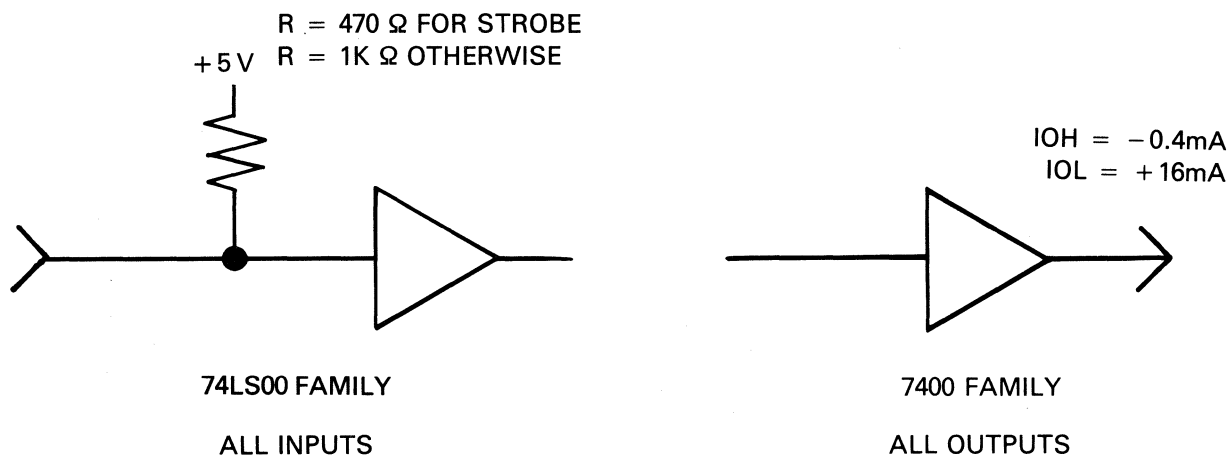
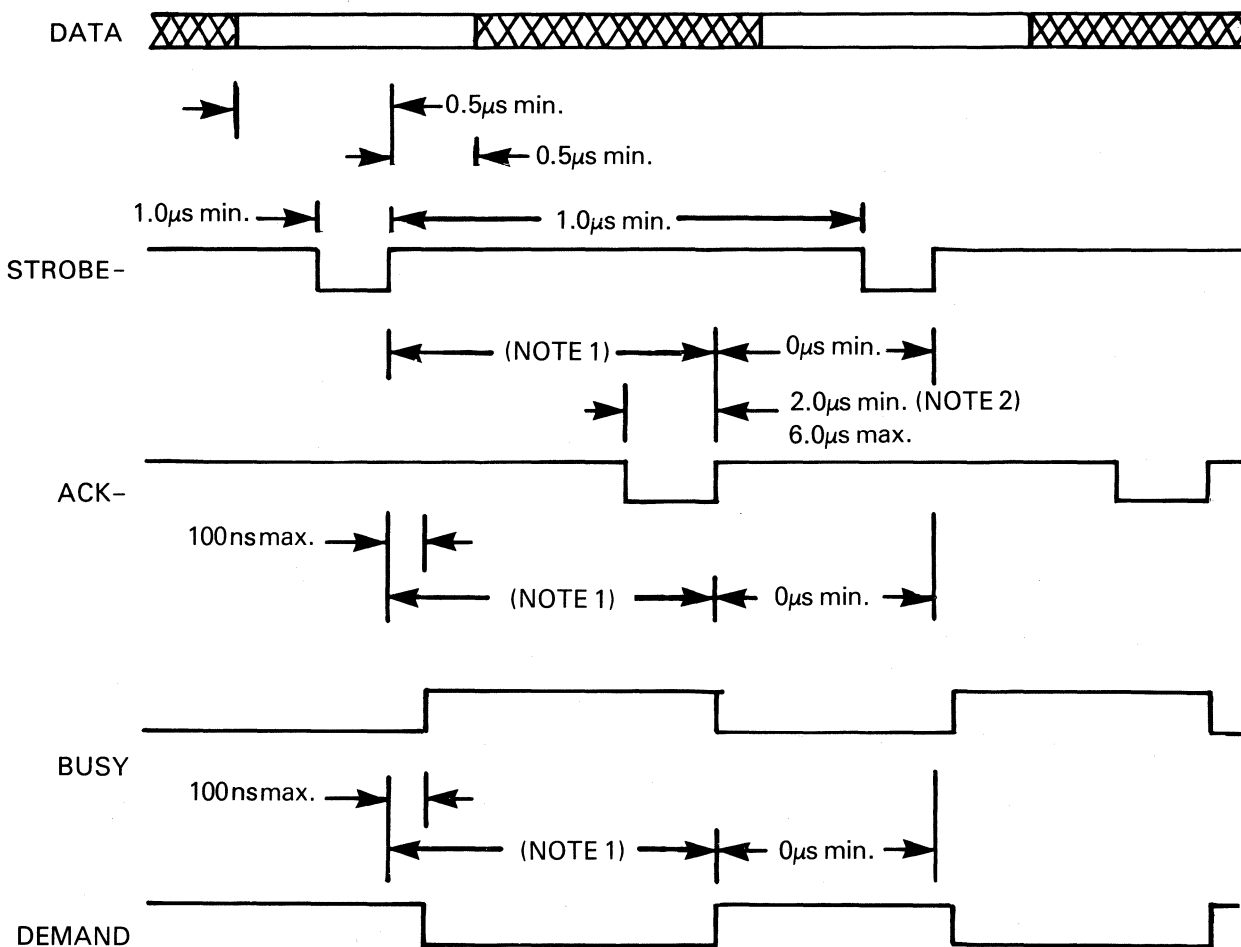

Figure 7-3. Parallel Interface Electrical Characteristics



NOTE 1: The average timing ($500\mu s$, $10\mu s$ min., $1000\mu s$ max.) is for characters that do not cause the receive buffer to be full.
 NOTE 2: ACK—Pulse width is $3.0\mu s$ nominal.

Figure 7-4. Parallel Data Communication Timing

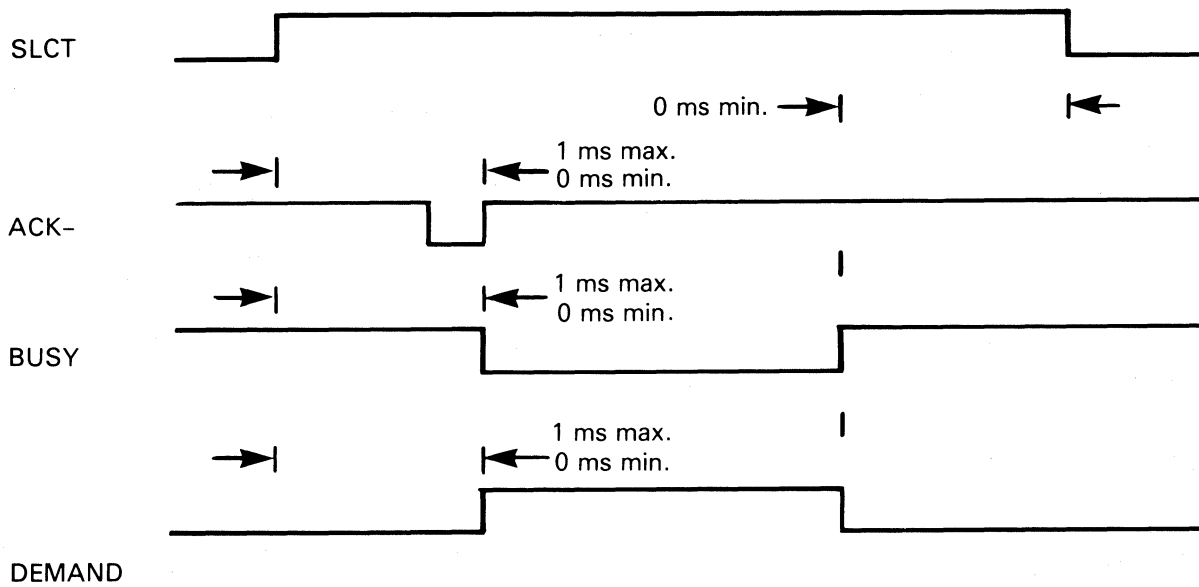

Figure 7-5. Going On Line and Off Line Timing

2222627-34

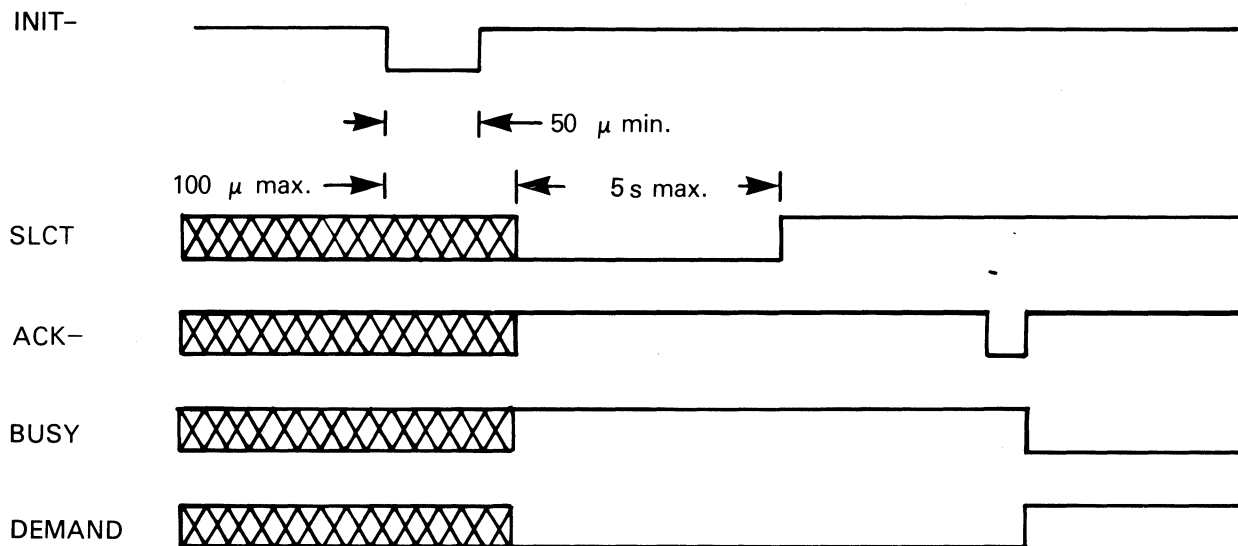

Figure 7-6. Timing Sequence to Initialize Printer

2222627-35

Appendix A

TI Business Systems Interface Instructions

A.1 INTRODUCTION

This appendix provides instructions for connecting the Model 880 Printer to the TI Business System 200, 300, 600, or 800. Refer to the following documents for specific programming or other information regarding the printer or individual system interfaces.

- *Model 880 Printer Maintenance Manual* (TI Part No. 2222628-0001)
- *System 200 General Description Manual* (TI Part No. 2533251-9701)
- *System 200 Maintenance Manual* (TI Part No. 2533252-9701)
- *System 300 General Description Manual* (TI Part No. 2533308-9701)
- *System 300 Maintenance Manual* (TI Part No. 2533309-9701)
- *Model 990/10A General Description Manual* (TI Part No. 2302633-9701)
- *C1402 Installation and Operation Manual* (TI Part No. 2263895-9701)
- *C1403 Installation and Operation Manual* (TI Part No. 2263897-9701)

A.2 INTERFACE INSTRUCTIONS

Use the control panel to enter the menu mode and print the configuration report. Select baud rate code 27. Refer to the instructions in Section 3.3.2, "Configuration Report and Menu." Both logic and chassis ground should be isolated for Business System use. Refer to Appendix D, "Power Requirements and Grounding," for an explanation of how to change grounds.

Refer to Sections 2 and 3 of this manual for printer installation and operation procedures.

CAUTION

Be sure to tighten the securing screws on all cable connectors to provide proper cable grounding and shielding. Failure to securely fasten these connectors could result in errors in the data transmitted to the printer and/or noncompliance with FCC regulations.

A.2.1 Business System 200/300 and 931/940 Terminals

Use the following procedure to connect the Model 880 Printer to the Business System 200/300 or the 931/940 Terminal.

1. Attach connector P1 of the interface cable (TI Part No. 2230504-0001) to the AUX 1 port at the rear of the terminal.

2. Tighten the two securing screws.
3. Attach connector P2 of the interface cable to the Model 880 Printer serial interface connector.
4. Tighten the two securing screws.

Figure A-1 shows the wiring diagram for this connection.

A.2.2 Business System 600 and 800 Terminals

Use the following procedure to connect the Model 880 Printer to the Business System 600 or 800 Terminal. The procedure applies to both the 10A central processing unit (CPU) COMM port and the CI402 or CI403 communications interface module.

1. Attach connector P1 of the interface cable (TI Part No. 2303080-0001) to the CPU COMM port at the edge of the 10A board or to the module port at the edge of the Communications Interface Module board.
2. Attach connector P2 of the interface cable to the Model 880 Printer serial interface connector.
3. Tighten the two securing screws.

Figure A-2 shows the wiring diagram for this connection.

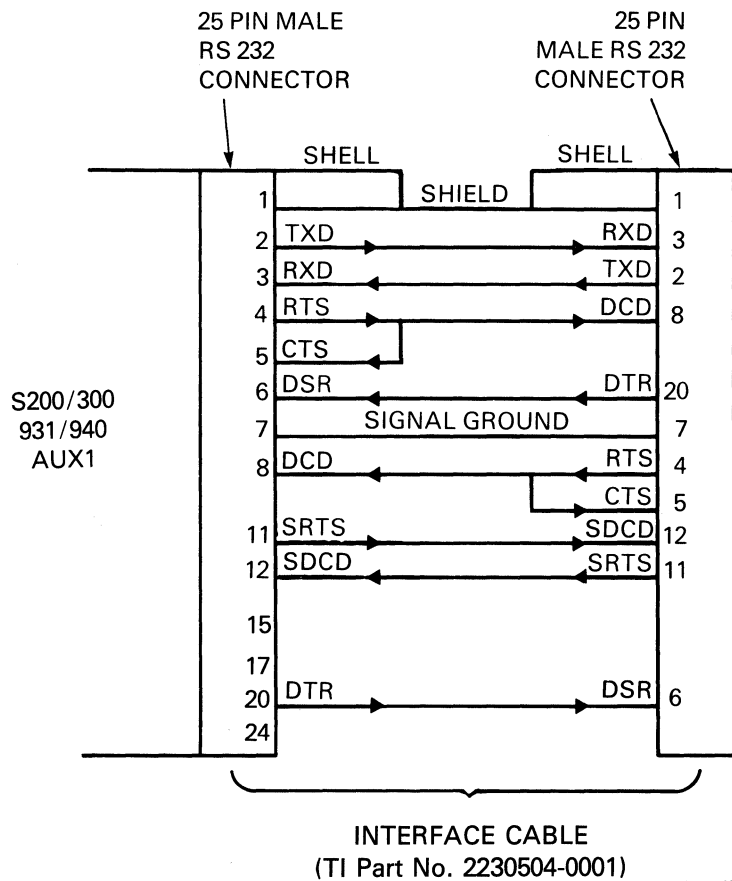

Figure A-1. Business System 200/300 and 931/940 Interface Diagram (AUX1 Port)

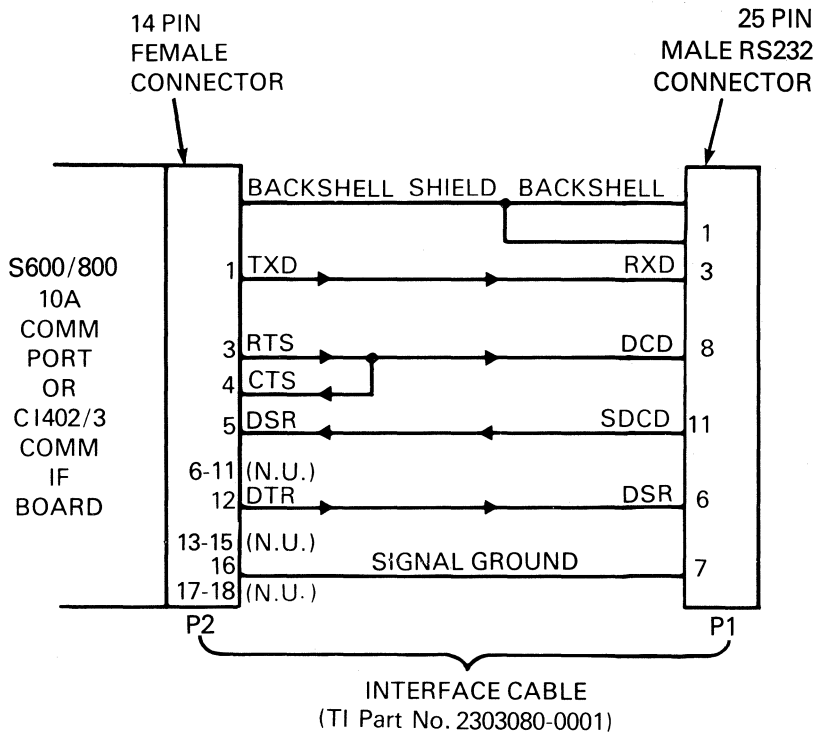

Figure A-2. Business System 600 and 800 Interface Diagram

Appendix B

Maintenance

B.1 TEMPERATURE

The operating temperature range of the Model 880 Printer is from 41° to 104° F (5° to 40° C). The non-operating temperature range is from -22° to 158° F (-30° to 70° C).

CAUTION

The Model 880 Printer is cooled by an internal cooling fan which pulls air from the right side vent of the printer and pushes air out the vent on the left side. Make sure that these vents are not obstructed.

B.2 CLEANING

For best performance, the printhead and ribbon area of the Model 880 Printer should be cleaned at least every 3 months. Clean whenever noticeable dust appears on the printhead tip or carriage rods.

WARNING

Set the printer *ON/OFF* switch to the *OFF* position to avoid electrical shock hazards.

1. Remove the power cable from the power receptacle.
2. Lift the printhead cover.
3. Carefully vacuum paper chaff from the printhead and ribbon areas.
4. Manually slide the carriage to the left and to the right in order to vacuum beneath the printhead.
5. Clean both carriage rods with a clean dry cloth.

CAUTION

DO NOT use cleaning agents on the Model 880 Printer, or oil the carriage rods.

6. Connect the power cable.
7. Close the printhead cover and set the **ON/OFF** switch to the **ON** position.

Appendix C

Control and Character Codes

C.1 CHARACTER CODES

Table C-1 lists the ASCII characters with their hexadecimal, decimal, and binary codes.

Table C-1. ASCII Code Characters

		Most Significant Bits							
		0	1	2	3	4	5	6	7
Hex Code	Hex Code	0000	0001	0010	0011	0100	0101	0110	0111
0	0000	NUL 0	DLE 16	SP 32	0 48	@ 64	P 80	\ 96	p 112
1	0001	SOH 1	DC1 17	! 33	1 49	A 65	Q 81	a 97	q 113
2	0010	STX 2	DC2 18	" 34	2 50	B 66	R 82	b 98	r 114
3	0011	ETX 3	DC3 19	# 35	3 51	C 67	S 83	c 99	s 115
4	0100	EOT 4	DC4 20	\$ 36	4 52	D 68	T 84	d 100	t 116
5	0101	ENQ 5	NAK 21	% 37	5 53	E 69	U 85	e 101	u 117
6	0110	ACK 6	SYN 22	& 38	6 54	F 70	V 86	f 102	v 118
7	0111	BEL 7	ETB 23	' 39	7 55	G 71	W 87	g 103	w 119
8	1000	BS 8	CAN 24	(40	8 56	H 72	X 88	h 104	x 120
9	1001	HT 9	EM 25) 41	9 57	I 73	Y 89	i 105	y 121
A	1010	LF 10	SUB 26	* 42	: 58	J 74	Z 90	j 106	z 122
B	1011	VT 11	ESC 27	+ 43	; 59	K 75	[91	k 107	{ 123
C	1100	FF 12	FS 28	, 44	< 60	L 76	\ 92	l 108	 124
D	1101	CR 13	GS 29	- 45	= 61	M 77] 93	m 109	} 125
E	1110	SO 14	RS 30	. 46	> 62	N 78	^ 94	n 110	~ 126
F	1111	SI 15	US 31	/ 47	? 63	O 79	_ 95	o 111	DEL 127

C-2. NATIONAL LANGUAGE VERSIONS

Table C-2 shows the national language versions with characters that differ from the United States version.

Table C-2. National Language Characters that Differ from US ASCII Characters

Country and Configuration Code	Hexadecimal Code											
	23	24	40	5B	5C	5D	5E	60	7B	7C	7D	7E
United States (basic) 41	#	\$	@	[\]	^	`	{		}	~
France WP 42	£	\$	à	°	ç	ç	^	`	é	ù	è	..
United Kingdom 43	£	\$	@	[\]	^	`	{		}	~
Germany/Austria 44	#	\$	ç	Ä	Ö	Ü	^	`	ä	ö	ü	ß
Sweden/Finland 45	#	☒	É	Ä	Ö	Å	Ü	é	ä	ö	å	ü
Denmark/Norway 46	#	\$	@	Æ	Ø	Å	^	`	æ	ø	å	~
Spain/Latin America 47	#	\$	@	í	Ñ	¿	^	`	°	ñ	ç	~
Switzerland 48	£	\$	à	é	ç	è	^	`	ä	ö	ü	..
Canadian French 49	#	\$	à	â	ç	ê	î	ô	é	ù	è	û

222627-41

0.2 CONTROL CHARACTERS

The character codes include 33 control characters. The characters shown in Figure C-1, C-2, or C-3 are printed when configuration code 87 is set ON, and the printer receives control characters. The hexadecimal value appears next to each character.



2222627-36

Figure C-1 ASCII Control Characters — 7X9 @ 5,6,10,12 CPI Draft

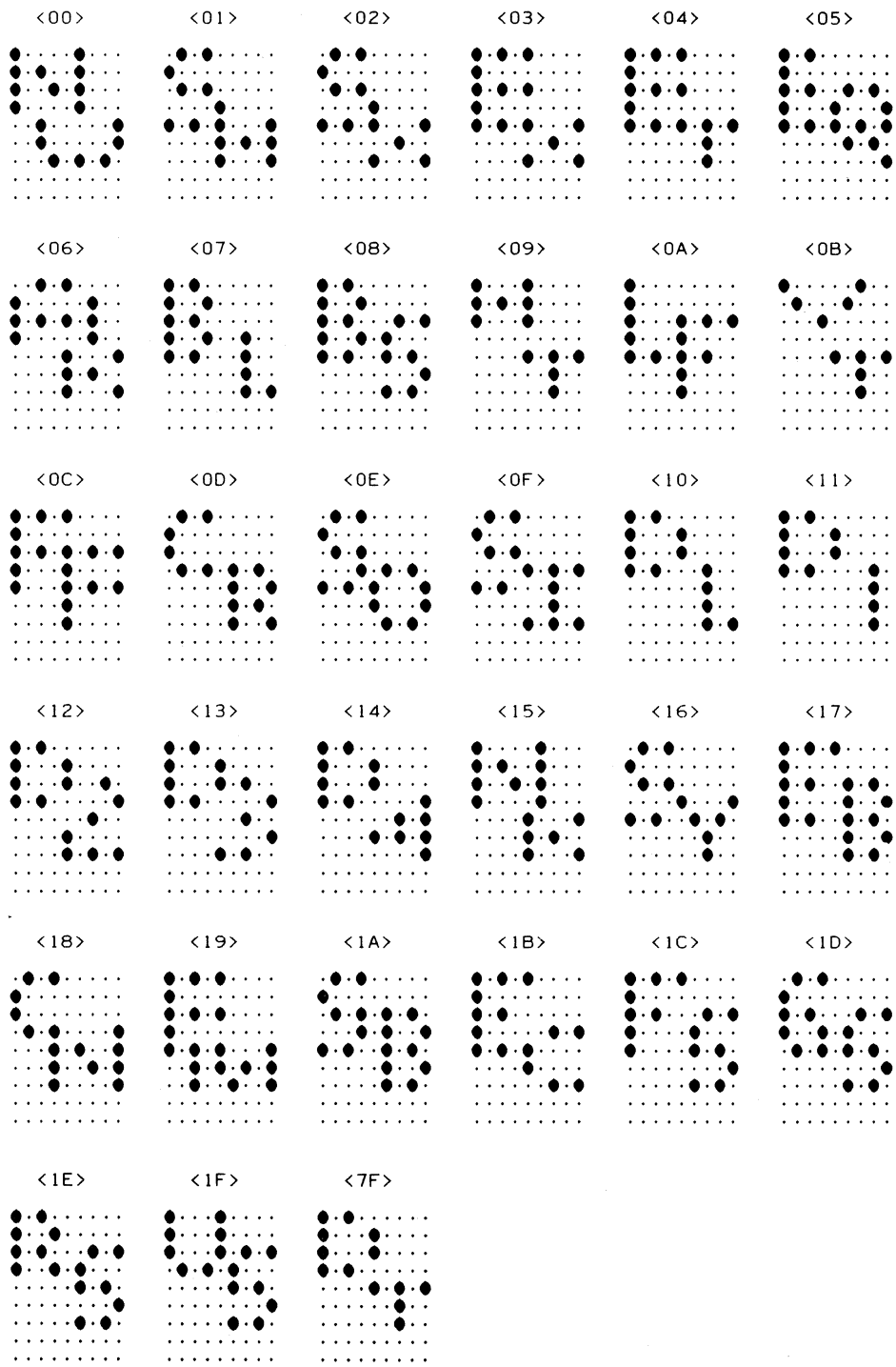

2222627-40

Figure C-2. ASCII Control Characters — 9X9 @ 8,16 Draft

<00>-<1F>, <7F>

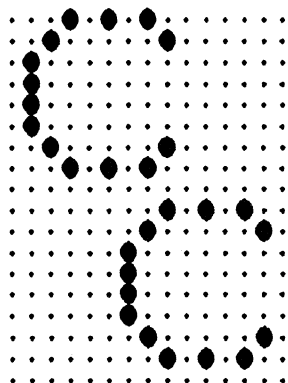

Figure C-3. ASCII Control Characters — 15X18 @ 5,6,10,12 CPI Enhanced



Appendix D

Power Requirements and Grounding

D.1 POWER REQUIREMENTS

The Model 880 Printer can operate over four ranges of single-phase RMS voltages.

- 100 Vac nominal + 10%, – 15%
- 120 Vac nominal + 10%, – 15%
- 220 Vac nominal + 10%, – 15%
- 240 Vac nominal + 10%, – 15%

CAUTION

Refer to the identification label on the back of your printer for correct voltage levels. An incorrect voltage can cause damage to the printer.

The Model 880 will operate normally from ac mains at 47 to 63 hertz.

WARNING

Do not use a power receptacle that does not accept a three-wire plug. Do not cut the ground pin from the plug. An electrical hazard can result.

D.2 SAFETY CONSIDERATIONS

For the safety of the operator, and for correct operation, the printer must be connected to ground by inserting the power cable into a compatible three-pin receptacle which is connected to ground as specified by the *National Electrical Code* and local codes and ordinances. The following conditions can cause possible hazards or can cause faulty printer operation:

- Open safety ground
- Safety ground connected to the hot lead
- Safety ground connected to the neutral lead in the receptacle
- Safety ground connected to conduit only
- Hot and neutral connections reversed in receptacle

If a wall receptacle with correct wiring is not available, the user must have a correct receptacle installed by a qualified technical person.

For correct operation, it is recommended that the printer not be installed on the same circuit with copy machines, water coolers, or similar devices that cause power-line transients. If faulty printer operation occurs as a result of the operation of other devices, the user must connect the printer to a different circuit or install devices to suppress transient voltages.

D.3 EARTH GROUND

In some installations the earth ground of the power receptacle is provided by a metal conduit that connects to the neutral phase at the circuit-breaker box. As determined by site conditions, this metal conduit can conduct current from other sources that can cause faulty operation of a printer connected at the receptacle. To prevent this occurrence, it is recommended that the earth ground and neutral be isolated from the conduit (except at the circuit-breaker) for the computer system and printer circuit as shown in Figure D-1. This will assure that the protection ground conducts only fault and leakage current from the printer or computer system.

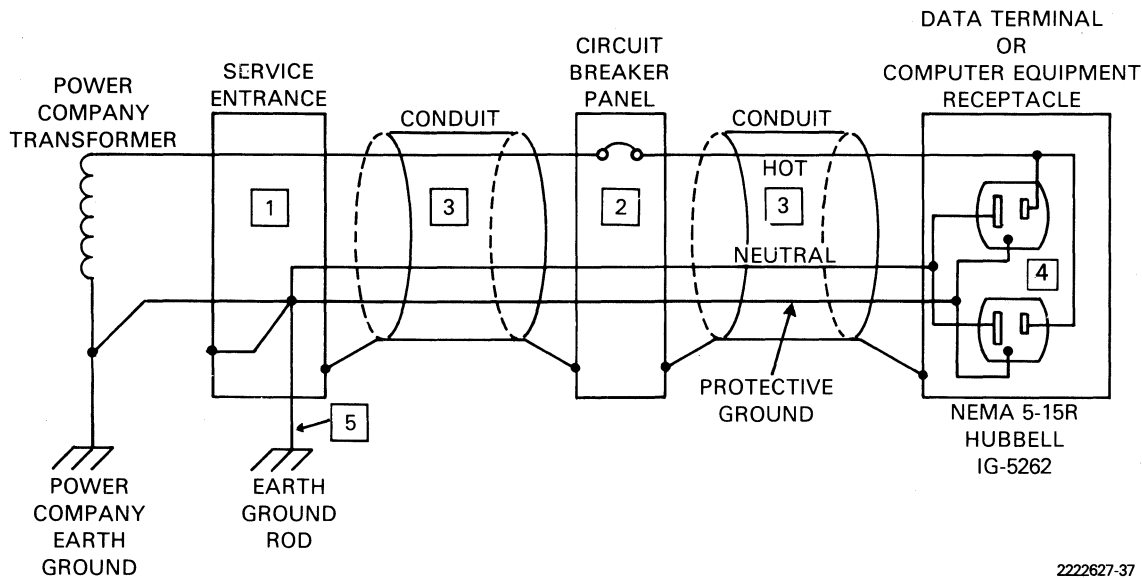

Figure D-1. AC Power Network and Ground

NOTE 1: Neutral and protection ground are connected together at a single point where power comes into the site (service entrance).

NOTE 2: Neutral and protection ground are isolated from each other except where connected at the service entrance.

NOTE 3: Neutral and protection ground are isolated from the conduit except where connected at the service entrance. This is done with a HUBBELL IG-5262 receptacle connected to comply with the *National Electrical Manufacturers Association Specification, NEMA 5-15R*.

NOTE 4: The protection ground wire must have a resistance of less than 1 ohm.

NOTE 5: Earth ground must have a resistance of less than 1 ohm.

D.4 SINGLE-POINT GROUNDING RULE

Protection ground is connected to the printer frame (chassis ground), which is connected to earth ground through the ac power cable. Signal ground is the common reference voltage level for all the interface circuits except protection ground. Signal ground and protection ground are connected; this connection must be made at only one point in a directly connected system to prevent a ground loop. A ground loop results in current that can cause faulty operation of the equipment.

Incorrect characters, parity errors, characters not printed, and even component damage can be symptoms of multiple system grounds. If these problems appear, the signal-ground/protective-

ground connection must be checked, and the correct configuration made.

Normally, the connection between protection ground and signal ground is made in the equipment with the greatest ac power (current) requirement. When the printer is connected directly to a system, such as a host computer that uses more ac current than the printer, it is recommended that the single point ground be made at that system and not at the printer. The data cable must have a protection ground wire. When the cable does not have a protection ground, connections must be made to short the protection ground and signal ground in the printer and in the modem or host computer on the other end of the data cable. This connection must be as specified by the equipment company and not made in the data cable.

D.5 CHANGING SIGNAL GROUND / PROTECTION GROUND

WARNING

Disconnect the power cable before removing the cover! Failure to remove the power cable will result in a serious shock hazard. Changing the signal ground/protection ground jumper should only be done by a qualified technical person.

The Model 880 Printer is normally assembled with protection ground and signal ground connected by a jumper plug between E4 and E5 on the Motherboard.

When a system needs the signal-chassis ground to be isolated, remove the jumper plug between E4 and E5 and place it between E4 and E3 for storage.

If you are not sure which configuration to use, measure the resistance between pins 1 and 7 of

the serial data cable with the cable connected to the system. If an open circuit is measured, the jumper plug must be installed between E4 and E5. If a short circuit is measured, the jumper plug between E4 and E5 must be removed and installed between E4 and E3 for storage. Refer to Figures D-2 and D-3.

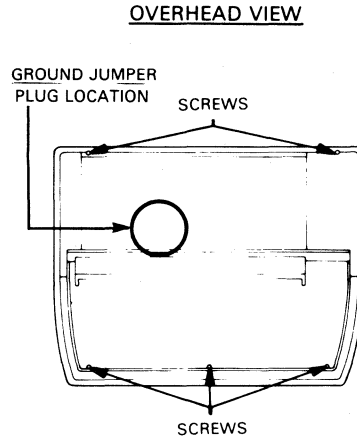

2222627-38

Figure D-2. Locations of Printer Cover Screws

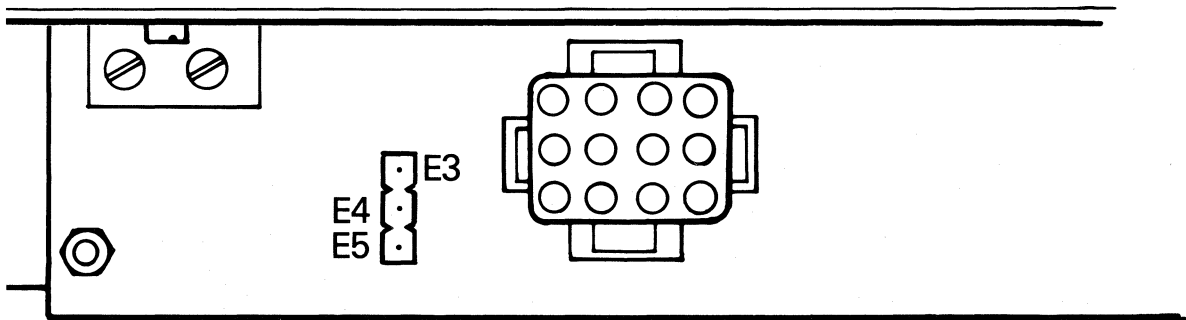

2222627-39

Figure D-3. Signal Ground/Protection Ground Jumper Plug



Appendix E

Options and Accessories

E.1 OPTIONAL CHARACTER SET ROMS

Optional character set ROMs are available only for the Model 880 Printer (not the Model 880 DP) and, once installed, can be selected from the control panel in the menu mode, or by the software in escape sequences.

E.2 INPUT BUFFERS

Optional input buffers are used by both the serial and parallel interfaces for storage of input data.

E.2.1 4K Input Buffer

The input buffer can be optionally expanded to 4096 bytes.

E.2.2 16K Input Buffer

The input buffer can be optionally expanded to 16 384 bytes.

E.3 PAPER TEAR BAR

An optional tear bar is available to assist the operator in tearing the paper. It is used on forms up to 389 mm (15.3 in) wide and tears the forms 856 mm (3-15/16 in) above the top dot of the current print line.

E.4 PRINTER STAND

A printer stand is available as an option.

E.5 STAND-MOUNTED PAPER TRAY

A paper tray, designed to be mounted to the printer stand, is available as an option.

E.6 PRINTER-MOUNTED PAPER TRAY

An optional paper tray, designed to be mounted to the printer, is available.

E.7 CURRENT LOOP INTERFACE

The Current Loop Interface option is a half-size board which plugs into the communication controller slot. The interface uses a four-wire, passive, neutral current loop which does not interfere with the standard RS-232-C serial interface. Data can be received from either interface, provided the other interface is in a spacing condition or its connector is unplugged.

E.8 RS422 INTERFACE

The RS422 Interface is a four-wire serial communication system which is electrically balanced to provide better performance at high speeds and longer distances than is possible for RS-232-C. Operation at 9600 baud at distances up to 1200 meters (4000 feet) is possible with this option.

The RS422 Interface option is a half-size board which plugs into the communication controller slot.

E.9 RIBBON

Replacement ribbons are available in economical six-packs (TI Part No. 2246601-0002).

Appendix F

Specifications

F.1 POWER REQUIREMENTS

Voltages:	100, 120, 220, 240 Vac (+ 10%, - 15%)
Frequency:	50 or 60 Hz, single phase
Power:	250 W maximum
Power Fuses:	100 Vac or 120 Vac range: 2-A, 250-V fuse slow blow 220 Vac or 240 Vac range: 1-A, 250-V fuse slow blow

F.2 PHYSICAL DIMENSIONS

Width:	654 mm (25.75 inches)
Depth:	508 mm (20 inches)
Height:	203.2 mm (8.0 inches)
Weight:	25 kg (55 pounds)

F.3 ENVIRONMENT

Operational Temperature:	+ 5°C (+ 41°F) to + 40°C (+ 104°F)*
Storage Temperature:	- 30°C (- 27°F) to + 70°C (+ 158°F)

*Up to 2134 m (7000 feet) mean sea level (MSL).
Linearly derate temperature to 25° C (77° F) at
3048 m (10 000 feet) MSL.

Operational Humidity:	10% to 90% (no condensation)
Storage Humidity:	5% to 95% (no condensation)

F.4 AUDIBLE NOISE

Noise Level:	65 dB (A-weighted) maximum at 1 meter
--------------	--

F.5 PRINTER

Method:	Wire matrix impact
Patterns:	7 by 9 (7 wide, 9 high) draft font dot matrix for 10 and 12 cpi 9 by 9 dot matrix for 16-2/3 cpi 15 by 18 enhanced font dot matrix (Model 880) 15 by 9 enhanced font dot matrix (Model 880 DP)
Paper Drive:	Tractors (4 pins each tractor)
Paper Feed:	Back or bottom
Paper Slew Rate:	72.39 mm per second (2.85 ips) (Model 880) 211.84 mm per second (8.34 ips) (Model 880 DP)
Printhead Slew Rate:	1143 mm per second (45.0 ips)

Printing Speed: 300 characters per second (CPS) for 10 cpi and 12 cpi draft font. 250 CPS for 16.7 cpi draft font. 75 CPS for 10 cpi and 12 cpi enhanced font. (Model 880) 150 CPS for 10 cpi and 12 cpi enhanced font. (Model 880 DP)

Line Feed Time: 59.2 ms @ 6 LPI (Model 880) 33.0 ms @ 6 LPI (Model 880 DP)

Adjustments: Form width and thickness

Indicators: Power, communication status, paper-out, and error

Fault Detector: Paper-out, carriage faults, data errors

Ribbon: 36.58 m (40 yards), automatic reversing, (TI Part No. 2246601-0001)

Character Spacing: 2.54 mm per character (10 cpi), 2.12 mm per character (12 cpi), 1.52 mm per character (16-2/3 cpi)

Characters Per Line: 132 characters per 335 ± 2 mm (13.2 ± 0.08 inches) 132 maximum (10 cpi), 158 maximum (12 cpi) 220 maximum (16-2/3 cpi)

Line Spacing: 2.4 per 10 mm (6 lines per inch) 3.15 per 10 mm (8 lines per inch)

Form length: 356 mm (14 inches) maximum

F.6 PAPER

Paper Width: 76.2 mm (3 in) to 481.0 mm (14-7/8 in)

Paper: Continuous feed, fanfold.

Weight: Single part — 5.44 kg (12 lb) minimum, 15.9 kg (35 lb) maximum

F.6.1 MULTIPLE PART CARBON-TYPE FORMS

Parts: Thickness — 0.0508 mm (0.002 in) Weight — 5.44 kg (12 lb)

Carbons: Thickness — 0.0254 mm (0.001 in) Weight — 3.4 kg (7.5 lb) Premium quality carbons (glued edges).

Total: Thickness — 0.3937 mm (0.015 in) Cardboard allowed on last copy only.

F.6.2 MULTIPLE PART CARBONLESS-TYPE FORMS (e.g., MOORE CLEANPRINT BOLD IMAGE™)

Original (coated back): Thickness — 0.0635 mm (0.0025 in) Weight — 5.89 kg (13 lb)

Parts 2 — 4 (coated front and back): Thickness — 0.0762 mm (0.0030 in) Weight — 6.57 kg (14.5 lb)

Part 5 (coated front): Thickness — 0.0635 mm (0.0025 in) Weight — 6.57 kg (14.5 lb)

Total: Thickness — 0.3556 mm (0.014 in) Cardboard allowed on last copy only.

NOTE

Paper must have holes meeting International Standards Organization (ISO) Standard 2784, i.e., holes must be placed 6.35 mm (0.25 in) from the paper edge and 12.7 mm (0.5 in) from each other, with hole diameters of 4.0 mm (5/32 in).

Cleanprint Bold Image is a trademark of Moore Incorporated.

F.7 CHARACTER SETS

Standard
Model 880: 128 ASCII characters,
and 8 national language charac-
ter sets:
France WP
United Kingdom
Germany/Austria
Sweden/Finland
Denmark/Norway
Spain/Latin America
Switzerland
Canadian French

F.8 GRAPHICS

Vertical: 7-dot and 8-dot formats
Horizontal: 6-dot format

F.9 COMMUNICATION INTERFACES

Input
Buffer: 2048 (standard), 4096 or
16 384 characters optional.
256 characters by configu-
ration.

F.9.1 Serial

Method: EIA RS-232-C
Type
Transmission: Asynchronous
Code: ASCII
Modes: Full duplex
Bits
per Second: 110, 200, 300, 600, 1200, 2400,
4800, 9600, 19 200
Parity: Transmit odd, even, mark,
space, 8-bit data. Check odd,
even
Line Control: Printer READY/BUSY
DC1/DC3

F.9.2 Parallel

Protocols: DEMAND/STROBE
STROBE/ACK/BUSY

Index

A

Accept Key 2-8, 3-3, 3-5—3-11,
3-14—3-16, 3-18, 4-1, 4-2
ACK 5-1, 7-3, 7-6, C-1, F-3
Alternate Character Sets 1-2, 3-15—3-18,
5-6—5-10
Applications Controller Board 4-2, 5-7
Audible Tone 2-7, 5-2

B

Backspace (BS) 5-1, 5-2, C-1
Barberpole Test 2-8, 4-1, 4-5
Battery Failure 4-3
Baud Rate 3-1, 3-8—3-10, 3-12, 3-18,
4-4, A-1
BEL 5-1, 5-2, C-1
BUSY 7-1—7-6

C

Carbon Copies F-2
Carriage Movement Error 3-2, 4-3, 4-5,
7-6, F-2
Carriage Return (CR) 3-13, 5-1, 5-2, 6-5, C-1
Change Key 2-8, 3-2—3-5, 3-14—3-16, 3-18,
4-1, 4-2
Character Set Designation 3-1, 3-15, 3-18,
4-2, 5-10
Character Set Invocation 5-9
Character Set Report ... 3-1, 3-4, 3-13—3-15, 3-17
Character Set ROMs..... 3-13, 3-14, E-1
Character Sets 3-13—3-16, 5-1, 5-6—5-10
Chassis Ground 7-5, A-1, D-2
Clear to Send (CB) 7-4
Command Indicator 3-1—3-4, 3-15,
4-1, 4-2
Command Key 3-1—3-5, 3-9, 3-15, 4-1
Command Mode 3-1—3-4
Configuration Code 3-9—3-13, 3-18,
4-4—4-6, 5-7, 5-9, 6-1, 7-1, 7-4, 7-5, C-3

Configuration Report 3-1, 3-2, 3-8, 3-11,
4-5, A-1
Control Characters 5-1—5-3, 5-7—5-9,
C-3, C-4

D

Data Cable 2-1, 2-9, 4-5
Data Set Ready (CC) 7-4
Data Terminal Ready (CD) 7-4
DCD 4-5, 4-6
Default Features 3-18, 5-4, 5-6
DEMAND 7-3, 7-5, 7-6, F-3
Device Control (DC) 3-13, 5-1—5-3, C-1
DLE 5-1, C-1
Double-Density Graphics 6-5
Double Wide Pitch (Expanded Print) 3-13, 5-6
Draft Font 1-1, 1-2, 3-6, 3-7, 5-3, F-1
DSR 4-5, 4-6

E

Earth Ground 2-7, 7-4, D-1, D-2
EIA F-2
Eight-Bit Data 5-9, 6-1, 7-3
Electrostatic Discharge 2-2, 4-3
End of Message (EM) 5-1, 5-3, C-1
End of Transmission (EOT) 5-1, 5-2,
6-5, C-1
Enhanced Font 1-1, 1-2, 3-6, 3-7, 5-3, F-1
Enquiry (ENQ) 5-1, 5-2, 6-4, 6-5, C-1
Error Codes 4-2—4-4
Error Indicator 3-2, 4-5
Escape Sequences 5-3—5-6, 5-9, 5-10,
6-2, E-1
Expanded Print 3-13, 5-6
Expansion Buffer 4-3

F

FAULT- 7-6
Fonts 1-1, 1-2, 3-1, 3-4—3-7, 3-16,
4-3, 5-10, F-1

Form Align Key 3-2—3-4
 Form Feed (FF) 5-1, 5-2, 6-4, 6-5, C-1
 Form Feed Key 3-2—3-4
 Form Length 3-1, 3-3, 3-4, 3-6, 3-7, 3-17,
 4-4, 5-3, 5-4, 6-3, F-2
 Form Report 3-1, 3-3, 3-5, 3-6, 3-17
 Full-Duplex Modem Mode 3-12
 Fuses F-1

G

G-Left (GL) 3-15, 3-16, 3-18, 5-7, 5-9, 5-10
 Graphics 1-1, 3-13, 6-1—6-5, F-3
 G-Right (GR) 3-15, 3-16, 3-18, 5-8, 5-9
 Grounding 2-2, 2-6, 2-7, 4-4, 4-5, A-1,
 D-1—D-3
 Ground Loop D-2
 Group Select (GS) 5-1, 5-3, 5-8, C-1
 G-Sets 5-6, 5-7, 5-9

H

Horizontal Graphics 3-13, 6-1, 6-4, 6-5
 Horizontal Pitch 5-4, 5-5
 Horizontal Tab (HT) 5-1, 5-2, C-1
 Horizontal Tabs 5-4, 5-5
 Host Computer 6-1, 7-1, D-2

I

INIT- 7-5, 7-6
 Input Buffer 1-1, 4-3, 7-1, E-1, F-2,
 In-Use Character Set 5-6

J

Jumper Plug 7-6, D-3

L

Line Feed (LF) 3-13, 5-1, 5-2,
 6-3, 6-4, 6-5, C-1
 Line Feed Key 3-2, 3-3, 3-4
 Line Spacing 6-3, F-2
 Line Termination Character 6-5
 Loopback Board 4-5, E-1

M

Margins 3-1, 3-6—3-8, 3-17,
 5-4, 6-3—6-5
 Menu Indicator 2-7, 3-5, 3-9, 3-15, 4-5
 Menu Mode 3-1, 3-4, 3-5, 3-8,
 3-14, 3-16, E-1
 Modem 3-12, 7-3, D-2
 Motherboard 7-6, D-3
 Multicopy Printing 2-5, 3-13
 Multipart Forms 2-5, F-2

N

National Language 3-8—3-10, 3-12, 3-18,
 5-9, C-2, F-2
 Non-Recoverable Power-Up Error 4-5
 Normal Indicator 2-7, 3-1, 3-4, 3-5,
 3-9, 3-15, 4-1, 4-2
 Normal Key 2-8, 3-3, 3-4, 3-7, 3-8
 3-11, 3-14, 3-16, 4-1, 4-3, 4-6
 Normal Mode 3-1—3-5, 3-7, 3-11,
 3-14, 3-16, 4-1
 NUL 5-1, 5-2, C-1

O

On Line Indicator 2-7, 2-8, 4-2, 4-5, 4-6
 On Line Key 2-8, 4-2

P

Paper Basket 2-1—2-3
 Paper Empty (PE) 7-5, 7-6
 Paper Jam 4-5, 7-6
 Paper Out Indicator 2-7, 4-3, 4-5
 Paper Out Switch 2-5, 4-5, 7-5
 Paper Path 2-2, 2-5, 2-6
 Paper Tear Bar E-1
 Parallel Interface 1-1, 2-8, 3-12, 4-3,
 7-1, 7-3, 7-5—7-7, F-3
 Parity 3-1, 3-9—3-12, 4-4, 4-5
 7-3, D-2, F-3
 Parity Code 3-10—3-12, 4-5
 Perforation-Skip 3-1, 3-4—3-7
 3-16, 3-17, 5-4
 Platen 2-4, 2-7, 2-8, 4-6
 Power Cable 2-1, 2-6, 2-8, 4-5, 4-6,
 B-1, D-1, D-2
 Power Indicator 2-7, 3-2, 4-6
 Power Line Transients D-1
 Power Switch 2-6—2-8, 4-5
 Power-Up Carriage Movement 2-7
 Power-Up Test 1-1, 2-7, 4-5, 7-6
 Printer Controller Board 4-2
 Printer Stand 1-1, 1-2, E-1
 Print Features Switch 3-6, 3-16—3-18, 4-4
 Print Features Switch Override 4-4
 Printhead 2-1, 2-8, 4-1, 4-3, 4-5, B-1
 Printhead Adjustment Lever 2-4—2-8
 Protective Ground (AA) 7-4

R

Raster Graphics 3-13, 5-2, 6-1
 Ready/Busy Signal 7-1, 7-2, 7-4
 Recalling Defaults 3-18
 Receive Buffer 3-1, 4-2

Received Line Signal Detector (CF) 7-4
Request to Send (CA) 7-4
Reset Key 3-2, 3-3, 4-3—4-5, 7-6
Ribbon 2-1, 2-4—2-6, 4-5, B-1, F-2
Ribbon-Reversing Eyelet 2-4
ROMs 3-13, 4-3, E-1

S

Serial Interface 1-1, 2-8, 2-9, 3-12, 4-3,
4-5, 5-2, 5-3, 5-6, 7-1, E-1, F-2
Set Top of Form Key 3-3, 3-4
Seven-Bit Data 5-7, 5-8, 6-1, 7-3
Shift In (SI) 5-1, 5-2, C-1
Shift Out (SO) 5-1, 5-2, C-1
Signal Ground 7-5, 7-6
Signal Ground (AB) 7-4
Single-Density Graphics 6-4
Single Pass Overstrikes 5-3
SLCT 7-6, 7-8
Slew Rate F-1

Standard Pitch 3-13, 5-6
Start Bit 7-3
Status Report 3-2, 3-3, 3-4, 4-1, 5-6
STROBE- 7-5, 7-6

T

Tab Set Key 3-3, 3-4
Test Indicator 2-7, 4-1, 4-2
Test Mode 3-1—3-4, 4-1, 4-2
TI Business Systems 2-8, A-1
Tractor Locking Lever 2-5, 2-6
Tractors 2-5, 2-6, F-1
Transmitted Data (BA) 7-4

U

UART 4-3

V

Vertical Pitch 3-7, 5-6
Vertical Tabs 3-1, 3-3, 3-4, 5-5

NOTES

FOLD



NO POSTAGE
NECESSARY
IF MAILED
IN THE
UNITED STATES

BUSINESS REPLY MAIL
FIRST CLASS PERMIT NO. 6189 HOUSTON, TX

POSTAGE WILL BE PAID BY ADDRESSEE

Texas Instruments Incorporated
Attn: Technical Publications M/S 7878
P.O. Box 1444
Houston, TX 77251



FOLD

Sales and Service Offices of Texas Instruments are located throughout the United States and in major countries overseas. Contact the Data Systems Group, Texas Instruments Incorporated, P.O. Box 1444, Houston, Texas 77251, or call (713) 895-3000 for the location of the office nearest to you.



Texas Instruments reserves the right to change its product and service offerings at any time without notice.

**TEXAS
INSTRUMENTS**



**TEXAS
INSTRUMENTS**

