

MITSUBISHI**Service
Manual**

COLOR MONITOR

**MODEL
AUM-1371A
AUM-1371A(C)****CAUTION**

Before servicing this product, it is important that the serviceman reads the "SAFETY PRECAUTIONS" and "PRODUCT SAFETY NOTICE" in this service manual.

SPECIFICATIONS

- **Picture tube** 13" viewable, 90 degree deflection
.31 mm trio dot pitch
Super high contrast glass, Non-glare
P22, Medium-short persistence
High voltage: 22.5kV (at 0mA)
- **Video**
- Band width** 30 MHz
- **Resolution** Mode 1. RGB TTL/Analog
800 dots Horizontal
560 lines Vertical
Mode 2. Composite Video
300 dots Horizontal
500 line Vertical
- **Input Signal** Comp. video: NTSC
RGB: video: TTL Positive 16/64
Colors
Analog 0.6 Vp-p positive
Sync.: Separate sync. TTL±HD, ±VD
Comp. sync. TTL ±HD/VD
- **Connector** BNC Jack
D-Sub 9-pin
D-Sub 25-pin
- **Synchronization** Horizontal: 15.6 kHz to 35 kHz
(Automatically)
Vertical: 45 Hz to 75 Hz
(Automatically)
- **Power Input** NTSC.... AC 120 V 60 Hz
- **Power Consumption** 90 watts
- **Dimension** 362 mm(W)×328 mm(H)×383 mm(D)
14-1/4"×13"×15-25/32"
- **Unit Net Weight** 12.8 kg (28.2 lbs)
- **Special Features**
 - * Automatic tracking of wide rang horizontal and vertical scanning frequencies.
f(H): 15.6 ~ 35 kHz
f(V): 45 ~ 75 Hz
 - * Size and position of the screen can be adjusted with external controls.
 - * High-resolution color CRT, 0.31mm trio dot pitch, diamond matte coating super-high Contrast glass.
 - * Supports wide variety of input signals such as, video composite, RGBI TTL, RGB analog and TTL monochrome.
 - * Diverse displays are obtainable by inputs of various signals such as composite video, RGB TTL, analog and monochrome.

MITSUBISHI ELECTRIC CORPORATION

Head Office: Mitsubishi Denki Building. Marunouchi Tokyo, Japan
Cable Address: MELCO TOKYO

SAFETY PRECAUTIONS

NOTICE. Observe all cautions and safety related notes located inside the color monitor cabinet and on the color monitor chassis.

WARNING

1. Operation of this color monitor, outside the cabinet or with the cover removed, involves a shock hazard from the color monitor power supplies. Work on the color monitor should not be attempted by anyone who is not thoroughly familiar with precautions necessary when working on high-voltage equipment.
2. Do not install, remove or handle the picture tube in any manner unless shatter-proof goggles are worn. People not so equipped should be kept away while the picture tube is being handled. Keep the picture tube away from the body while handling.

X-RADIATION WARNING

The surface of the picture tube may generate X-Radiation. Precaution during service and, if possible, the use of a lead apron is recommended for shielding while handling.

When replacing the picture tube, use only the designated replacement part since it is a critical component with regard to X-Radiation as noted above. (No high-voltage adjustments are provided.) The high-voltage specification is described on page 1.

LEAKAGE CURRENT CHECK

Before returning the color monitor to the customer, it is recommended that leakage current be measured according to the following methods.

1. Cold Check

With the AC plug removed from the Power source, place a jumper across the two AC plug prongs. Turn the color monitor AC switch on. Using an ohm-meter, connect one lead to the jumpered AC plug and touch the other lead to each exposed metal part (screwheads, metal overlays, control shafts, etc.) particularly any exposed metal part having a return path to the chassis. Exposed metal parts having a return path to the chassis should have a minimum resistance reading of 1 megohm. Any resistance below this value indicates an abnormality which requires corrective action. Exposed metal parts not having a return path to the chassis will indicate an open circuit.

2. Hot Check (AUM-1371A · AUM-1371A(C))

The test sequence, with reference to the measuring circuit in Fig.1, is as follows:

- (1) With switch S1 open, the color monitor is to be connected to the measuring circuit. Immediately after connection, the leakage current is measured using both positions of switch S2, and with the switching devices in the color monitor in all of their operating positions.
- (2) Switch S1 is then to be closed, energizing the color monitor, and immediately after closing the switch, the leakage current is to be measured using both positions of switch S2, and with the switching devices in the color monitor in all of their operating positions.

Current measurements of items (1) and (2) are to be repeated after the color monitor has reached thermal stabilization.

The leakage current shall not be more than 3.5mA.

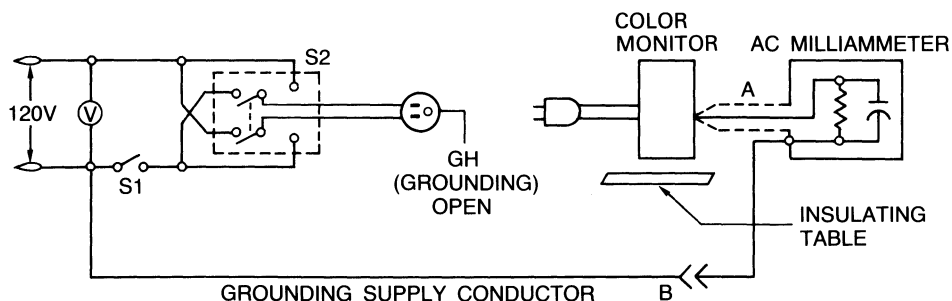

Fig. 1

PRODUCT SAFETY NOTICE

Many electrical and mechanical parts in color monitor have special safety related characteristics. These characteristics are often not evident from visual inspection nor can the protection afforded by them necessarily be obtained by using replacement components rated for higher voltage, wattage, etc. Replacement parts which have these special safety characteristics are identified in this service manual. Electrical components having such features are identified by shading on the schematic diagram and the parts list of this service manual and by marking on the supplementary sheet for this chassis to be issued subsequently. Therefore replacements for any safety parts should be identical in value and characteristics.



Fig. 2 Controls

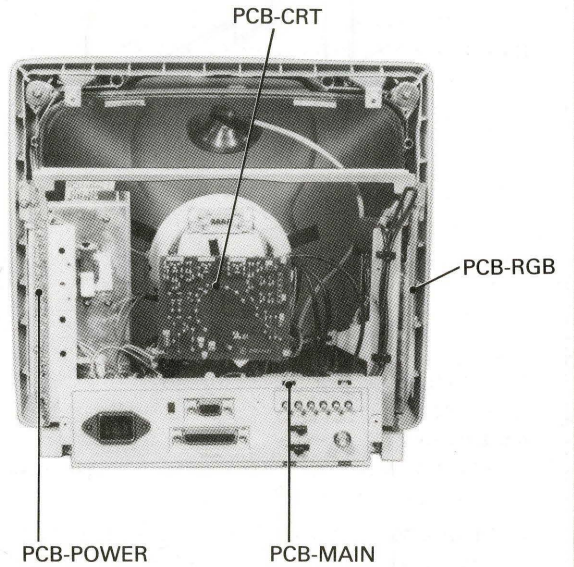

Fig. 3 Location of PCBs

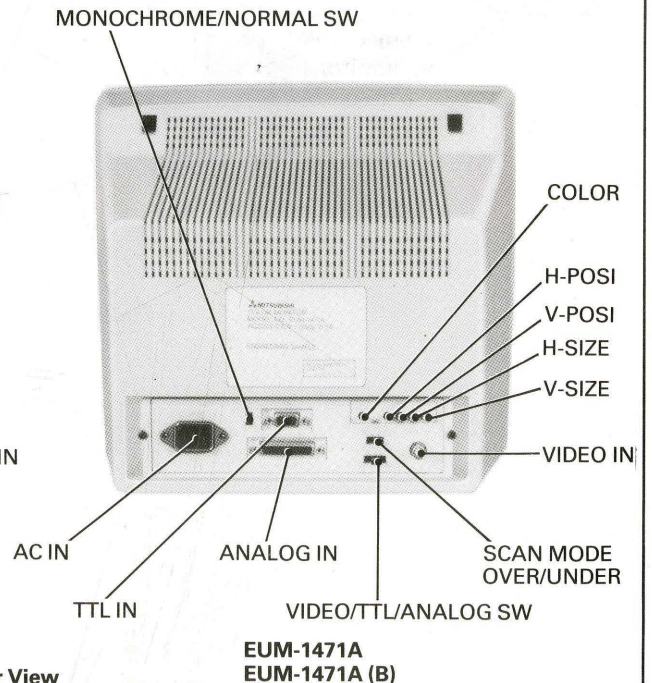
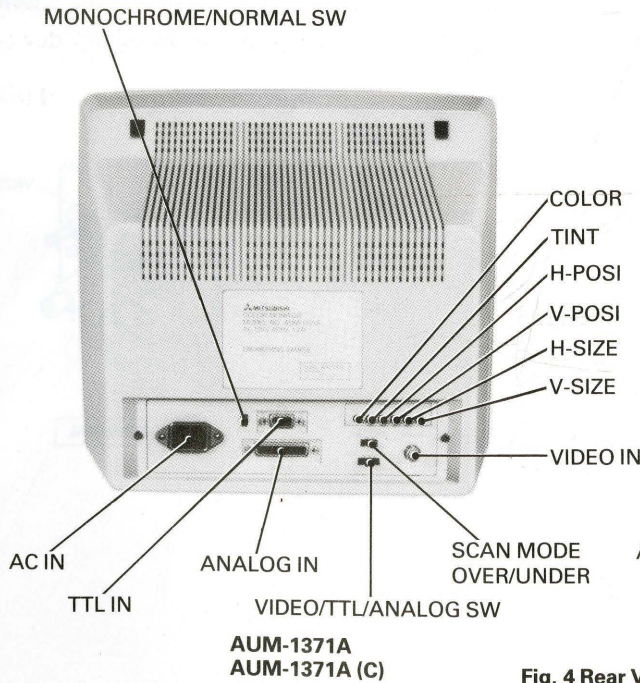

Fig. 4 Rear View

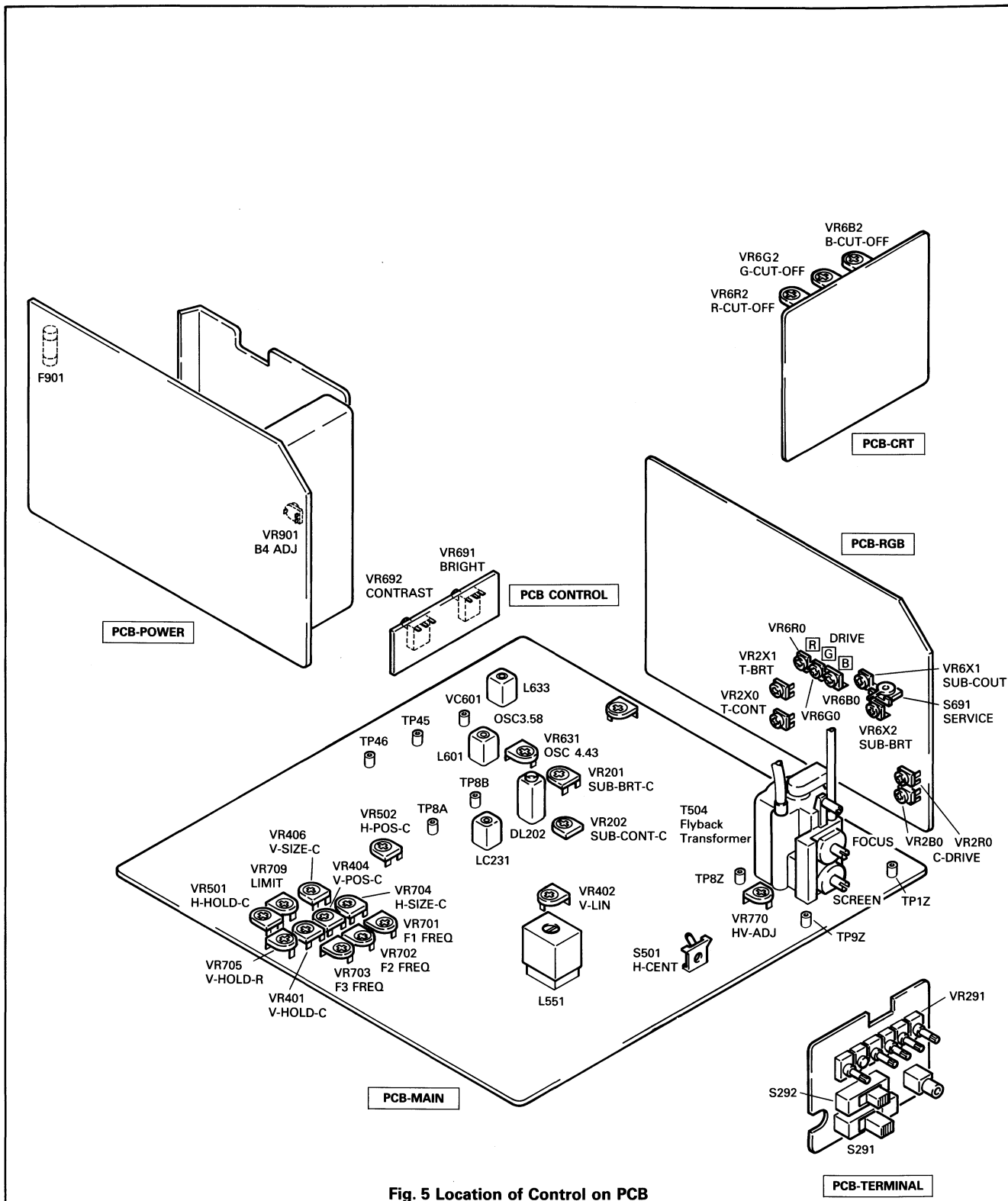
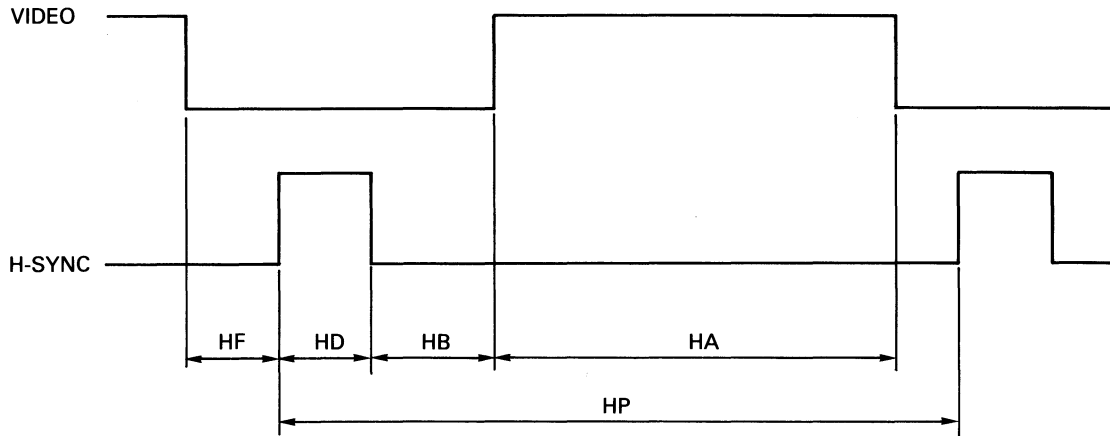

Fig. 5 Location of Control on PCB

TIMING CHART

HORIZONTAL



VERTICAL

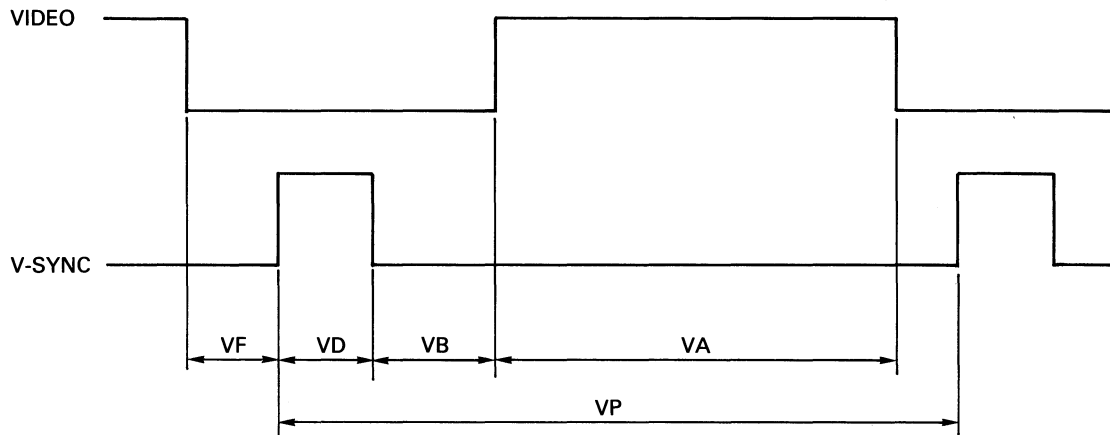

MODE	Horizontal Timing					Vertical Timing					Unit	f _H (kHz)	f _V (Hz)	Note
	HP	HF	HD	HB	HA	VP	VF	VD	VB	VA				
M1-2	63.78	6.47	4.45	8.03	44.83	16680	1640	190	2110	12740	μS	15.7	60	CGA
M2-1	45.75	-0.14	4.924	1.65	39.62	16750	44	595	100	16011	μS	21.8	59.7	EGA
M3-1	54.34	0.348	8.29	1.49	44.212	20040	51	868	133	18990	μS	18.4	50	MDA
M4-1	32	0.64	5.12	0.64	25.6	16670	384	512	418	15356	μS	31.25	60	
M5-1	32.7	0.2	4.48	2.36	25.66	16650	97	65	816	15672	μS	30.5	60	PGA Mode control "H" 480 lines
M5-2	32.7	0.2	4.48	2.36	25.66	16650	1400	65	2120	13065	μS	30.5	60	PGA Mode control "L" 400 lines
M6-1	NTSC											15.734	60	
M6-2	PAL											15.625	50	

★ CHECK AFTER ADJUSTMENT

Test of X-radiation protector circuit

- 1) Set INPUT SIGNAL SELECT SWITCH S291 at the "VIDEO" position.
Do not supply video signal.
- 2) Turn off the Power switch.
- 3) Connect a 180k Ω -J (R-composite 1/4W) resistor parallel with R799 in the horizontal deflection circuit.
- 4) Turn on the power switch.
- 5) Make sure that X-radiation protector has worked, namely, horizontal oscillation circuit has turned off.
- 6) Turn off the Power switch.
- 7) Remove the resistor connected parallel with R799.

SERVICE ADJUSTMENT

[1] +B4 Voltage Adjustment

- 1) Receive a white pattern signal. <M2-1>
- 2) Set RGB-SUB-CONT control VR6X1 at the center position, CONTRAST control VR692 at maximum position and BRIGHT control VR691 at the click stop position.
- 3) Make sure the AC power supply voltage is at the specified value.
- 4) Set SERVICE SWITCH S691 on PCB RGB at the inside position picture tube side to obtain a horizontal line of low brightness across the screen.
- 5) Adjust CRT-BIAS (SCREEN) control VR592A until any of the red, blue or green horizontal line appear on the screen.
- 6) Return SERVICE SWITCH S691 at the center position.
- 7) Connect a DC voltmeter of 150 V full scale between the TP-9Z on the PCB-POWER and the chassis ground (-).
- 8) Adjust B4-ADJ control VR901 on the PCB-POWER for 130 \pm 1 V reading on the meter.

[2] Vertical Deflection Alignment <RGB>

- 1) Receive a cross-hatch signal. <M2-1>
- 2) Set V-POS1 control VR291 on the rear panel so that the picture become center of raster and V-SIZE control VR291 so that vertical width becomes almost 176 mm.
- 3) Adjust V-LIN control VR402 for symmetry of vertical linearity.

- 4) Adjust V-SIZE control VR291 on the rear panel so that vertical width becomes 176 \pm 1.5 mm.

[3] Horizontal Deflection Circuit Alignment <RGB>

Horizontal Low Frequency Adjustment

Horizontal Width Adjustment

VR709, VR770 is permanently sealed at factory. Do not attempt to readjust.

[4] RGB VIDEO Circuit

RGB TTL Input level adjustment

- 1) Receive a gray scale of 16 colors (R, G, B, I) signal. <M2-1>
- 2) Connect the oscilloscope across TP47 on PCB-RGB and ground.
- 3) Adjust T-BRT control VR2X1 so that the wave becomes 0.68Vp-p \pm 0.02V.

RGB TTL SIGNAL White adjustment.

- 1) Receive a RGB TTL signal. <M2-1>
- 2) Set INPUT SIGNAL SELECT SWITCH S291 at the "TTL" position.
- 3) Set R, G, B-CUT-OFF control VR6R2, VR6G2, VR6B2 and SUB-BRT-control VR6X2 at full counterclockwise position.
- 4) Set R, G, B-DRIVE control VR6R0, VR6G0, VR6B0 at full clockwise position.
- 5) Set CRT-SCREEN control on the Flyback transformer at full counterclockwise position.
- 6) Set BRIGHT control VR691 at click stop position and CONTRAST control VR692 at maximum position.
- 7) Set SERVICE SWITCH S691 at the inside position (picture tube side).
- 8) Adjust CRT-SCREEN control until any of the red, blue or green horizontal line appear on the screen.
- 9) Adjust the CUT-OFF controls (VR6R2, VR6G2 or VR6B2) to produce a white horizontal line.
- 10) Return SERVICE SWITCH S691 at the outside position (CT connector side).
- 11) Adjust DRIVE control volume of two bright colors on the screen among R,G,B-DRIVE control VR6G0 VR6B0 and VR6R0 to obtain a pure peak white raster. (Signal: white pattern of TTL)

RGB Analog Signal White ADJUSTMENT

- 1) Set INPUT SIGNAL SELECT SWITCH S291 at the "ANALOG" position.
- 2) Receive a RGB ANALOG signal. (a gray scale of 16 graduations.)
- 3) Adjust SUB-BRT control VR6X2 to optimum brightness.

Note: Check overall black and white tone through the normal brightness and contrast range. If necessary, repeat steps from RGB TTL white adjust (7) to Analog white adjust (3).

RGB BEAM CURRENT ADJUSTMENT

- 1) Receive a TTL white raster (INTENSITY-"H") signal. <M2-1>
- 2) Connect a DC ammeter with 1 mA full scale between the test point TP9Z (+) and TP1Z (-) on PWB-MAIN.
- 3) Set BRIGHT control VR691 at click stop position, CONTRAST control VR692 at maximum position and H-SIZE control VR291 at minimum position.
- 4) Adjust SUB-CONT control VR6X1 for beam current of $530 \pm_{-0}^{20} \mu A$ on the meter.
- 5) Remove a DC ammeter from TP9Z and TP1Z.
- 6) Re-adjust HV-ADJ control VR770 so that a horizontal width becomes 240 ± 1 mm.

Note: Re-adjust white adjustment at this time.

- 7) Adjust V-SIZE control VR291 so that a vertical width becomes 176 ± 1.5 mm.

FOCUS adjustment

- 1) Receive a H-character (INTENSITY-"H") signal.
- 2) Adjust FOCUS control for best overall focus.

[5] COMPOSITE VIDEO CIRCUIT ADJUSTMENT.

CHROMA · OSC · VECTOR adjustment <AUM-1371A. AUM-1371A(C)>

- 1) Set INPUT SIGNAL SELECT SWITCH S291 at the "VIDEO" position.
- 2) Receive a NTSC color bar signal through "VIDEO IN" terminal.
- 3) Set TINT control and COLOR control on the rear panel to mid-position.
- 4) Short circuit the test points TP41 and TP42 with a short lead wire.
- 5) Connect a 270 k Ω resistor (composition 1/4W) across TP43 and TP44.
- 6) Adjust frequency control VC601 on PCB MAIN for almost color synchronization.
- 7) Remove the short lead wire and 270 k Ω resistor.
- 8) Set the oscilloscope to the X-Y mode. Connect the PCB-MAIN pin terminals TP46 (B-Y OUT) and TP45 (R-Y OUT) to the oscilloscope horizontal and vertical inputs respectively to display a vector pattern on the screen.
- 9) Adjust L601 so that a R-Y vector (Y-mode) becomes 105°.

CHROMA, OSC, VECTOR adjustment.

<EUM1471A · EUM1471A(B)>

- 1) Set INPUT SIGNAL SELECT SWITCH S291 at the "VIDEO" position.
- 2) Receive a PAL color bar signal through "VIDEO IN" terminal.
- 3) Set COLOR control on the rear panel to mid-position.
- 4) Short circuit the test points TP41 and TP42 with 2 short lead wire.
- 5) Connect 270 k Ω resistor (composition 1/4W) across TP43 and TP44.
- 6) Adjust OSC control VR631 for optimum color saturation.
- 7) Remove the short lead and 270 k Ω resistor. Receive a PAL G-card signal.
- 8) Set the oscilloscope to the X-Y mode. Connect TP46 (B-Y OUT) and TP45 (R-Y OUT) to the oscilloscope horizontal and vertical inputs respectively to display a vector pattern on the screen. (Fig. 6)

- 9) Set COLOR control VR291 on the rear panel at maximum position.
- 10) Observing the outermost dots which correspond to normal color bar, adjust the SCB-COLOR control VR601 and L633 on PCB-MAIN alternately to almost coincide the double dot pattern equally for all color points on the scope.
- 11) Observing around the center dots, adjust the coil L601 on PCB-MAIN so that the movable points on X axis or Y axis may come up to the nearest points of the center bright dot.
- 12) Repeat step 10) and 11) above so that the outer and center dots are converged.
- 13) Detune L601 so that the movable dots may be shifted and distinguished from the center bright point. (Fig. 6)
- 14) Observing the movable dots, AÁ and BB, adjust SUB-COLOR control VR601 on PCB-MAIN so that the double dots shifted in step 13) may come up to the nearest points of X or Y axis, (Fig. 6).
- 15) Adjust L633 slightly so that the outermost dots are converged again.
- 16) If the color of both sides are prominent slightly adjust the coil L601 so that the color of both sides is less on the average.

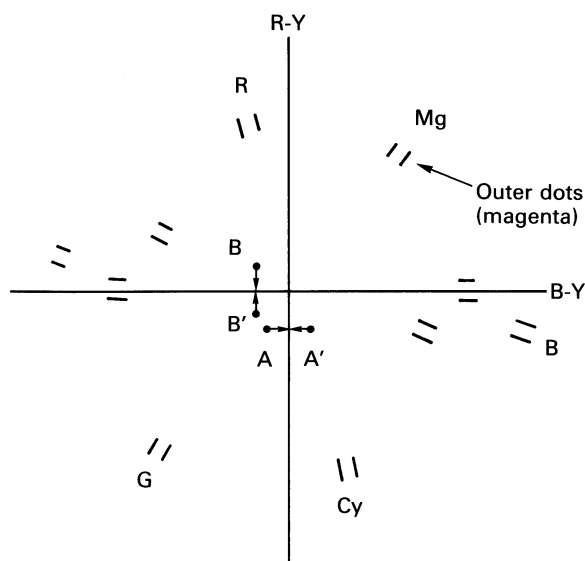

Fig. 6 Vector Pattern of G-card Signal

White adjustment

- 1) Set INPUT SIGNAL SELECT SWITCH S291 at the "VIDEO" position.
- 2) Receive a PAL or NTSC a monochrome signal through "VIDEO IN" terminal.
- 3) Set BRIGHT-control VR691 at click stop position, CONTRAST-control VR692 at maximum position, SUB-CONT control VR202 to mid-position, and C-DRIVE-R/C-DRIVE-B control VR2R0 and VR2B0 at about 45° counter clockwise position from the center.
- 4) Adjust C-DRIVE-R/C-DRIVE-B control VR2R0 and VR2B0 to obtain a pure peak white raster.
- 5) Adjust SUB-BRT control VR201 on PCB MAIN for optimum brightness.
- 6) Connect a DC ammeter (class 0.5 1 mA range) between the testpoint TP9Z (+) and TP1Z (-).
- 7) Adjust SUB-CONT control VR202 for beam current of NTSC MAX. in NTSC and $380 \pm_{0}^{20} \mu A$ in PAL on the meter.

Horizontal and Vertical Deflection adjust. (composite signal NTSC/PAL)

- 1) Receive a monochrome signal.
- 2) Short-circuit the test points TP8A and TP8B.
- 3) Adjust H-HOLD-C control VR501 for almost in synchronization.
- 4) Remove the short lead wire from TP8A and TP8B.
- 5) Adjust H-SIZE-C control VR704 at maximum position.
- 6) Adjust H-POSI-C control VR502, V-SIZE-C control VR406, V-POSI-C control VR404 for optimum position.

CHROMA adjustment (composite signal NTSC/PAL)

- 1) Receive a color bar signal.
- 2) Adjust COLOR-control on the rear panel for position.

[6] PURITY AND CONVERGENCE

Procedure

- 1) Remove the deflection yoke and the rubber wedges from the picture tube cone taking care not to strike or scratch the cone.
- 2) Clean the cement remaining on the deflection yoke and the surface of the picture tube cone.
- 3) Receive a full white raster.
- 4) Fit the deflection yoke on the neck of picture tube and push forward.
- 5) Fit C.P. (Magnet) Assembly to the neck of the picture tube and fasten with the screw at the position where the distance between 6-pole magnet end and the base of picture tube is as shown in Fig. 7.
- 6) Demagnetise at the front and sides of the picture tube with a degaussing coil.

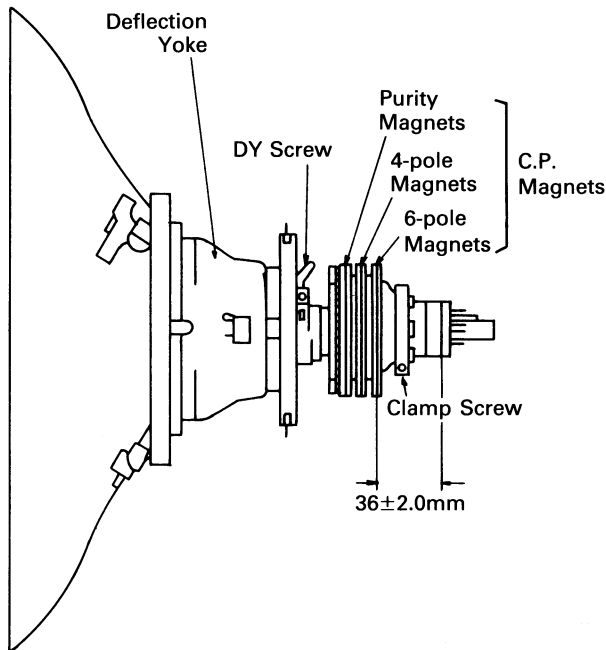

Fig. 7

Preliminary Adjustment

1 Purity

- 1) Short-circuit the base and emitter of B-OUT transistor Q6B0 on PCB-CRT to produce yellow raster.
- 2) With the deflection yoke positioned fully forward, adjust purity magnet so that the yellow ball is at the center of the screen. (Fig. 8)
- 3) Slide the deflection yoke slowly backwards to produce a uniform yellow raster.
- 4) Remove the shorting link on Q6B0.
- 5) Short-circuit the base and emitter of corresponding two transistors on PCB-CRT as indicated in Table 1 to produce green, red, and blue rasters and to verify their purity, and fasten the DY screw on the deflection yoke temporarily.
- 6) Remove the shorting leads from respective transistors.

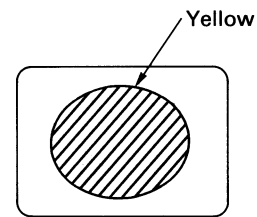

Fig. 8 Screen

Table 1 Transistors to be Short Base to Emitter to Produce Primary Color.

Transistor Raster	R-OUT Q6R0	G-OUT Q6G0	B-OUT Q6B0
Red	Open	Short	Short
Green	Short	Open	Short
Blue	Short	Short	Open

2 Static Convergence

- 1) Set BRIGHT control VR691 at click stop position and CONTRAST control VR692 at maximum position.
- 2) Adjust two 4-pole magnets to converge red and blue vertical and horizontal lines at the center of the screen.
- 3) Adjust two 6-pole magnets to converge the red and blue lines on green line at the center of the screen.

Note: 1. Adjustment of 4-pole magnets affects red blue beams.
2. Adjustment of 6-pole magnets affects red and blue beams. (Fig. 9)

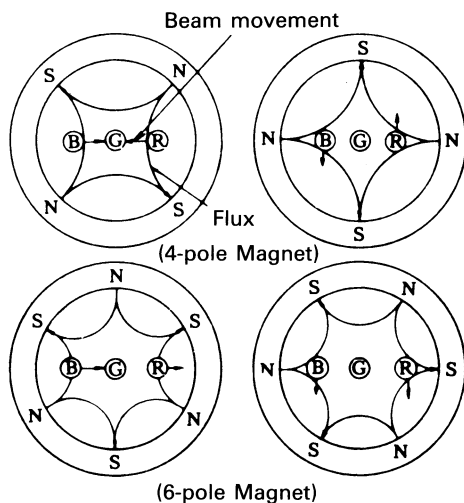

Fig. 9

3. Focus

If necessary, adjust focus. Ascertain that focus is optimum throughout the entire screen. Do not adjust focus after the following adjustments.

Regular Adjustment

1. Purity

- 1) Short-circuit the base and emitter of B-OUT transistor Q6B0 on PCB-RGB to produce yellow raster.
- 2) Loosen the deflection yoke screw and move it forwards and check that the yellow ball is at the screen center. (Fig. 8)
If necessary, adjust purity magnets.
- 3) Slide the yoke backwards to produce a uniform yellow raster.
- 4) Short-circuit the base and emitter of corresponding two transistors on PCB-RGB as indicated in Table 1 to produce green, red, and

blue rasters and verify their purity, then fasten the DY screw of the deflection yoke temporarily.

- 5) If necessary, repeat steps above.
- 6) Fix the yoke in position using the DY screw.

Note: When adjusting the deflection yoke position, do not touch the purity ring magnets except where necessary.

2. Static Convergence

- 1) Receive a cross-hatch signal.
- 2) BRIGHT control VR691 at click stop position and CONTRAST control VR692 at maximum position.
- 3) Adjust 4-pole magnets to converge red and blue vertical and horizontal lines at the center of the screen.
- 4) Adjust 6-pole magnets to place the red and blue lines converged on the green lines.
- 5) If necessary, repeat steps 3) and 4) above.

3. Periphery of Convergence

- 1) Observe the vertical lines at the center of screen. If the red and blue vertical lines are shifted crossing with green vertical lines as shown in Fig. 10 (A), converge then by swinging yoke vertically.

Observe the horizontal lines at the center of screen. If the red and blue horizontal lines are shifted crossing with green vertical lines as shown in Fig. 10(A), converge then by adjusting BIAS magnet on the PCB-MID.

Then confirm that vertical lines at the screen center are also converged.

- 2) Observe the vertical lines at left and right centers of the screen as shown in Fig. 10 (B). If red or blue vertical lines are shifted against green vertical line, converge them by swinging yoke horizontally. Then confirm that the horizontal line both at top and bottom centers of the screen are also converged.
- 3) The shift of beams as shown in Fig. 10 (C) can be converged by rotating the entire deflection yoke. The rotation of the yoke should be made in consideration of a point where raster rotation and convergence compromise.

Note: Never perform focus adjustment after convergence adjustments. If focus is adjusted after convergence adjustment, check convergence again.

- 4) Push the three rubber wedges between the picture tube cone and the deflection yoke at the positions indicated in Fig. 11.
- 5) Observe the entire screen and make sure convergence adjustment is complete. If necessary, change the positions of the wedges and repeat step 1) and 2) above.
- 6) After the position of the wedges have been decided, gently turn up the end of the wedge and strip the tape from the rear of the end to expose the adhesive material, then adhere to the picture tube cone. (Fig. 12)

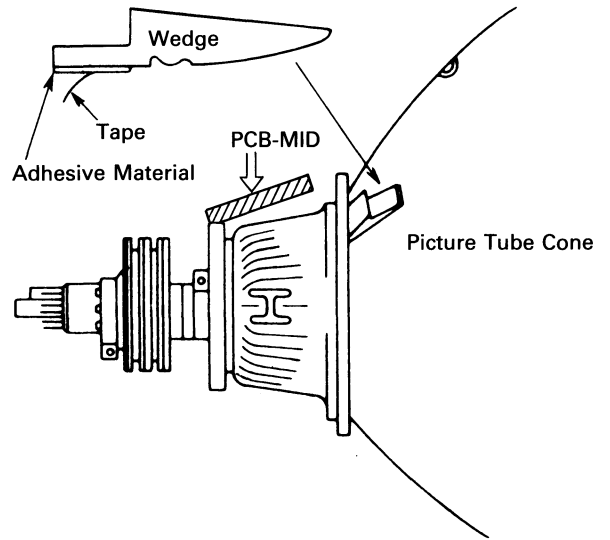

Fig. 12

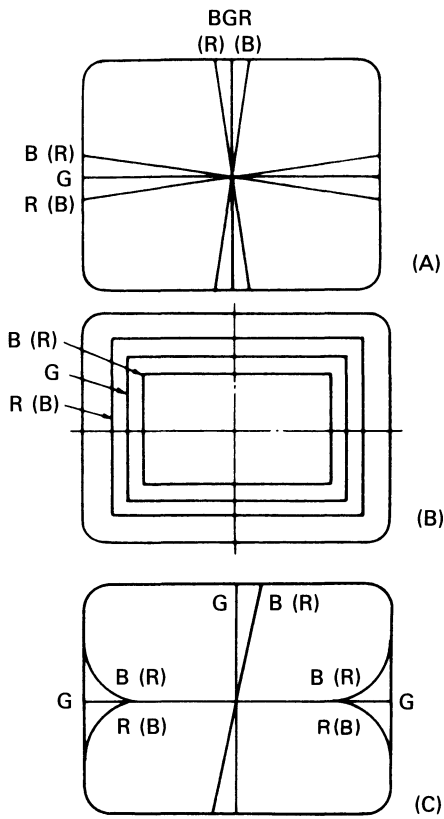

Fig. 10

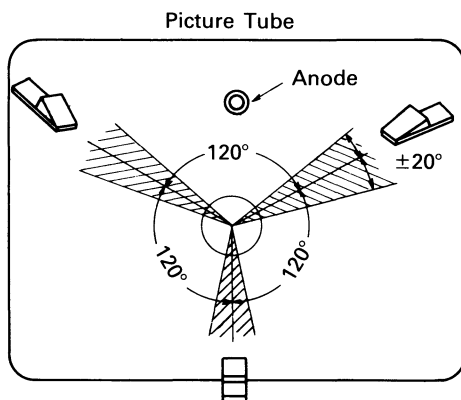

Fig. 11

**PARTS LIST (AUM-1371A, AUM-1371A(C),
EUM-1471A, EUM-1471A(B))**

In order to expedite delivery of replacement part orders,

- Specify: 1. Model number
2. Part number and Description
3. Quantity

Unless full information is supplied, delay in execution of orders will result.

█ : Critical components

RESISTOR

CAPACITOR

MARK	TOLERANCE
J	± 5%
K	±10%
M	±20%
N	±30%

MARK	TOLERANCE	MARK	TOLERANCE
J	± 5%	Z	+80% -20%
K	± 10%	C	±0.25pF
M	± 20%	D	±0.5pF
P	+100% - 0%	F	±1pF

SYMBOL NO.	PART NO.	DESCRIPTION	SYMBOL NO.	PART NO.	DESCRIPTION
TUBE			Q6B2	260P56101	2SA1371
			Q6B3	260P58201	2SK656
	251P25202	Picture tube AT1459ZAB22-A (AT1429.... CAN ALSO BE USED)	Q6G0	260P53301	2SC3598-E
			Q6G1	260P55801	2SC3467
			Q6G2	260P56101	2SA1371
			Q6G3	260P58201	2SK656
TRANSISTORS			Q6R0	260P53301	2SC3598-E
Q201	260P33804	2SC2603-E, F (AUM-1371A · AUM-1371A(C))	Q6R1	260P55801	2SC3467
Q202	260P33804	2SC2603-E, F (AUM-1371A · AUM-1371A(C))	Q6R2	260P56101	2SA1371
Q203	260P41904	2SC2724-C, D	Q6R3	260P58201	2SK656
Q204	260P33804	2SC2603-E, F	Q6X1	260P58201	2SK656
Q205	260P25601	2SA1115-E, F	Q6X2	260P58201	2SK656
Q206	260P25601	2SA1115-E, F	Q701	260P33804	2SC2603-E, F
Q207	260P58201	2SK656	Q702	260P33804	2SC2603-E, F
Q208	260P41904	2SC2724-C, D	Q703	260P33805	2SC2603-G
Q209	260P33804	2SC2603-E, F	Q704	260P45903	2SK381-C, D
Q291	260P45501	DTC124F	Q705	260P33804	2SC2603-E, F
Q292	260P45501	DTC124F	Q706	260P33804	2SC2603-E, F
Q2B1	260P41904	2SC2724-C, D	Q707	260P33804	2SC2603-E, F
Q2B2	260P16704	2SA673A-D	Q708	260P33804	2SC2603-E, F
Q2B3	260P16704	2SA673A-D	Q709	260P33805	2SC2603-G
Q2G1	260P41904	2SC2724-C, D	Q710	260P33805	2SC2603-G
Q2G2	260P16704	2SA673A-D	Q711	260P33805	2SC2603-G
Q2G3	260P16704	2SA673A-D	Q712	260P25601	2SA1115-E, F
Q2R1	260P41904	2SC2724-C, D	Q713	260P33804	2SC2603-E, F
Q2R2	260P16704	2SA673A-D	Q714	260P33804	2SC2603-E, F
Q2R3	260P16704	2SA673A-D	Q715	260P33804	2SC2603-E, F
Q2X1	260P41605	2SC2274-E, F	Q716	260P33804	2SC2603-E, F
Q2X2	260P41605	2SC2274-E, F	Q717	260P33804	2SC2603-E, F
Q2X3	260P38701	2SC2236-O, Y	Q718	260P45501	DTC124F
Q2X4	260P41605	2SC2274-E, F	Q719	260P45501	DTC124F
Q2X5	260P41904	2SC2724-C, D	Q721	260P25601	2SA1115-E, F
Q2X6	260P45501	DTC124F	Q770	260P33804	2SC2603-E, F
Q2X7	260P45501	DTC124F	Q771	260P33804	2SC2603-E, F
Q401	260P41602	2SC2274-E	Q772	260P33804	2SC2603-E, F
Q402	260P18603	2SB647A-B	Q773	260P33804	2SC2603-E, F
Q403	260P41802	2SC2481-O, Y	Q774	260P33804	2SC2603-E, F
Q501	260P42201	2SC2482	Q776	260P41605	2SC2274-E, F
Q502	260P55701	2SD1555	Q777	260P41605	2SC2274-E, F
Q503	260P38503	2SS2229-O, Y	Q778	260P33804	2SC2603-E, F
Q504	260P46901	2SA1320/2SA1321	Q779	260P33804	2SC2603-E, F
Q601	260P33804	2SC2603-E, F (AUM-1371A · AUM-1371A(C))	Q901	260P38701	2SC2236-O, Y
Q602	260P33804	2SC2603-E, F (AUM-1371A · AUM-1371A(C))	Q902	260P38701	2SC2236-O, Y
Q6B0	260P53301	2SC3598-E	Q951	260P38701	2SC2236-O, Y
Q6B1	260P55801	2SC3467	Q952	260P38601	2SC2230-GR
			Q953	260P38601	2SC2230-GR







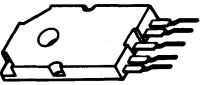

SYMBOL NO.	PART NO.	DESCRIPTION	SYMBOL NO.	PART NO.	DESCRIPTION
INTERGRATED CIRCUITS					
IC201	266P98201	AN-608P	D2R0	264P22001	MZ307B/EQA02-07CDA
IC202	266P01601	LA7016	D2R1	264P22001	MZ307B/EQA02-07CDA
IC2X1	266P45201	SN74LS05N/HD74LS05P	D2R2	264P19306	MZ312B/EQA02-11CDB
IC2X2	266P45201	SN74LS05N/HD74LS05P	D2X1	264P04504	1S2471
IC2X3	266P45701	SN74LS38N	D2X2	264P04504	1S2471
IC2X4	266P45701	SN74LS38N	D2X3	264P04504	1S2471
IC2X5	266P48601	SN74LS158N	D2X5	264P22003	MZ306/EQA02-06CDA
IC2X6	266P84801	SN74LS02N	D2X6	264P22003	MZ306/EQA02-06CDA
IC2X7	272P02701	AN5862K	D2X7	264P22001	MZ307B/EQA02-07CDA
IC2X8	272P05501	AN5860	D2X8	264P22001	MZ307B/EQA02-07CDA
IC2X9	266P93402	μ PC7812H	D2X9	264P22001	MZ307B/EQA02-07CDA
IC401	266P40501	AN5521	D2XC	264P04504	1S2471
IC601	266P15001	TA7698AP	D2XD	264P04504	1S2471
IC6X1	272P08101	M51387P	D2XE	264P04504	1S2471
IC701	266P84401	SN74LS123N	D2XF	264P22001	MZ307B/EQA02-07CDA
IC702	266P84902	SN74LS74AN/HD74LS74AP	D2XG	264P04504	1S2471
IC703	266P80601	M53206P/SN7406N	D2XH	264P04504	1S2471
IC704	266P84201	SN74LS42N	D401	264P28501	S5500D
IC705	263P53801	MC14538BCP	D402	264P04504	1S2471
IC706	263P53801	MC14538BCP	D502	264P23101	TVR1G
IC708	266P72701	μ PC339C/MC3302P	D503	264P24401	HZT33-01
IC709	266P93402	μ PC7812H	D504	264P28501	S5500D
IC710	263P89401	TC5081AP	D505	264P28501	S5500D
IC711	263P05309	TC4053BP/MC14053BCP/HD14053B	D506	264P28501	S5500D
IC712	263P05309	TC4053BP/MC14053BCP/HD14053B	D507	264P48706	RD12FB
IC713	266P41901	M5223P	D691	264P39302	SLC-26GG5
IC715	266P93209	NJM7805A/AN7805/L7805	D692	264P04504	1S2471
IC716	266P93402	μ PC7812H	D6B0	264P04504	1S2471
IC7X1	266P46802	SN74LS157N/HD74LS157P	D6B1	264P23101	TVR1G
IC7X2	266P45301	SN74LS14N	D6G0	264P04504	1S2471
IC7X3	266P47801	SN74LS86N	D6G1	264P23101	TVR1G
IC901	267P92101	STR59041	D6R0	264P04504	1S2471
IC951	267P91401	STR45111	D6R1	264P23101	TVR1G
DIODES & OTHERS			D6X1	264P04504	1S2471
D201	264P04504	1S2471	D701	264P04504	1S2471
D202	264P04504	1S2471	D702	264P22001	MZ307B/EQA02-07CDA
D203	264P04504	1S2471	D703	264P22001	MZ307B/EQA02-07CDA
D204	264P04504	1S2471	D706	264P04504	1S2471
D205	264P04504	1S2471	D707	264P04504	1S2471
D206	264P04504	1S2471	D708	264P04504	1S2471
D208	264P04504	1S2471	D709	264P04504	1S2471
D209	264P04504	1S2471	D710	264P22102	MZ308B/EQA02-08CDA
D210	264P04504	1S2471	D711	264P24401	HZT33-01
D211	264P22003	MZ306/EQA02-06CDA	D712	264P04504	1S2471
D212	264P04504	1S2471	D713	264P04504	1S2471
D291	264P04504	1S2471	D714	264P04504	1S2471
D292	264P04504	1S2471	D715	264P04504	1S2471
D293	264P22001	MZ307B/EQA02-07CDA	D716	264P04504	1S2471
D294	264P22001	MZ307B/EQA02-07CDA	D717	264P04504	1S2471
D295	264P22001	MZ307B/EQA02-07CDA	D718	264P04504	1S2471
D2B0	264P22001	MZ307B/EQA02-07CDA	D719	264P04504	1S2471
D2B1	264P22001	MZ307B/EQA02-07CDA	D720	264P04504	1S2471
D2B2	264P19306	MZ312B/EQA02-11CDB	D721	264P04504	1S2471
D2G0	264P22001	MZ307B/EQA02-07CDA	D770	264P04504	1S2471
D2G1	264P22001	MZ307B/EQA02-07CDA	D771	264P04504	1S2471
D2G2	264P19306	MZ312B/EQA02-11CDB	D772	264P04504	1S2471

SYMBOL NO.	PART NO.	DESCRIPTION	SYMBOL NO.	PART NO.	DESCRIPTION
DIODES & OTHERS			COILS		
D774	264P04504	1S2471	L201	321C03109	RF 33 μ H-K
D776	264P46107	EQA02-06D/RD6. 2EB2	L2X1	411D00902	Core-ferrite
D778	264P22006	MZ310B/EQA02-10CDA	L2X2	411D00902	Core-ferrite
D779	264P04504	1S2471	L2X3	411D00902	Core-ferrite
D780	264P04504	1S2471	L2X4	411D00902	Core-ferrite
D7X1	264P220001	MZ307B/EQA02-07CDA	L2X5	411D00902	Core-ferrite
D7X2	264P220001	MZ307B/EQA02-07CDA	L2X6	411D00902	Core-ferrite
D7X3	264P220001	MZ307B/EQA02-07CDA	L491	330B02301	Deflection yoke (AUM-1371A · AUM-1371A(C))
D7X4	264P220001	MZ307B/EQA02-07CDA	L491	330B02302	Deflection yoke(EUM-1471A)
D7X5	264P220001	MZ307B/EQA02-07CDA	L491	330D02001	Deflection yoke(EUM-1471A(B))
D7X6	264P04504	1S2471	L501	325C11201	Peaking 47 μ H-K
D7X7	264P04504	1S2471	L502	321C01001	RF 100 μ H-K
D7X8	264P22001	MZ307B/EQA02-07CDA	L551	333P01804	Horizontal linearity
D7X9	264P22001	MZ307B/EQA02-07CDA	L601	349P14102	Chroma-CW 3.58MHz
D901	264P47901	RB40C	L631	321C03109	RF 33 μ H-K (EUM-1471A · EUM-1471A(B))
D902	264P23101	TVR1G	L632	321C10102	Peaking 8.2 μ H-K (EUM-1471A · EUM-1471A(B))
D903	264P29501	ES-1	L633	349P14102	Chroma-CW 3.58MHz (EUM-1471A · EUM-1471A(B))
D904	264P23101	TVR 1G	L6B1	325C11403	Peaking 0.22 μ H-M
D905	264P10202	RU-3B	L6G1	325C11403	Peaking 0.22 μ H-M
D906	264P23101	TVR 1G	L6R1	325C11403	Peaking 0.22 μ H-M
D907	264P04502	1S2076A	L7X1	411D00902	Core-ferrite
D951	264P10204	RU-3M	L7X2	411D00902	Core-ferrite
D952	264P35807	RU-4AM	L7X3	411D00902	Core-ferrite
D953	264P35807	RU-4AM	L901	351P03103	Line-Filter (AUM-1371A · AUM-1371A(C))
D954	264P10202	RU-3B	L901	351P03101	Line-Filter (EUM-1471A(B))
D955	264P23101	TVR 1G	L901	351P04701	Line-Filter (EUM-1471A)
D956	264P10202	RU-3B	L951	351P03701	Filter
D957	264P29502	ES-1C	L952	351P03701	Filter
D958	264P23101	TVR1G	L953	351P03701	Filter
D959	264P23101	TVR1G	L955	351P03701	Filter
D960	264P10202	RU-3B	L956	351P03701	Filter
D961	264P23101	TVR1G	L958	351P03701	Filter
D962	264P30602	R2KN	L959	321C01009	RF 2,700 μ H-J
D963	264P30602	R2KN	DL201	337P09601	Delay line ADL-CX (AUM-1371A · AUM-1371A(C))
RP901	265P07101	Positive Thermistor (AUM-1371A · AUM-1371A(C))	DL202	337P06004	Delay line (EUM-1471A · EUM-1471A(B))
RP901	265P07103	Positive Thermistor (EUM-1471A · EUM-1471A(B))	DL202	337P09901	Delay line (AUM-1371A · AUM-1371A(C))
X601	285P01101	Quartz-Crystal-Unit 4.43MHz (EUM-1471A · EUM-1471A(B))	DL631	337P09001	Delay line ADL-CP144M (EUM-1471A · EUM-1471A(B))
X601	285P01505	Quartz-Crystal-Unit HC-18/U 3.579545MHz (AUM-1371A · AUM-1371A(C))	LC231	320P04502	Trap 4.43MHz (EUM-1471A · EUM-1471A(B))
TRANSFORMERS				409B06203	Degaussing (AUM-1371A · AUM-1371A(C))
T501	336P00903	Horizontal drive		409B06204	Degaussing (EUM-1471A · EUM-1471A(B))
T502	349P16404	Side-PCC	L901	351P04701	Line-Filter (EUM-1471A)
T503	349P16405	Side-PCC			
T504	334P13302	Flyback (AUM-1371A · AUM-1371A(C) · EUM-1471A(B))			
T504	334P13303	Flyback (EUM-1471A)			
T601	349P15902	Chroma-BP (AUM-1371A · AUM-1371A(C))			
T931	350P35002	Power			
T951	350P31302	Power			

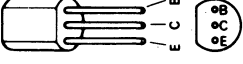
SYMBOL NO.	PART NO.	DESCRIPTION	SYMBOL NO.	PART NO.	DESCRIPTION
CAPACITORS & RESISTORS			C934	189P06703	C-Ceramic-AC F VA1 3,300 μ F-M (EUM-1471A(B))
C510	172P17003	C-M-Plastic-PP 1,600V 1,500pF-J (AUM-1371A · AUM-1371A(C)) (EUM-1471A(B))	C935	189P02707	C-Ceramic-AC F VA1 4,700pF-M (AUM-1371 · AUM-1371A(C))
C510	172P17202	C-M-Plastic-PP 1,600V 1,600pF-J (EUM-1471A)	C951	181P20800	C-Electrolytic 04W 35V 1,000 μ F-M
C511	172P17009	C-M-Plastic-PP 1,600V 4,700pF-J	C953	142P02308	C-Ceramic F50V 0.01 μ F-Z
C512	172P17102	C-M-Plastic-PP 1,600V 8,200pF-J	C954	181P18405	C-Electrolytic 04W 35V 470 μ F-M <105°C>
C513	181P20605	C-Electrolytic 04W 100V 1 μ F-M	C955	181P20308	C-Electrolytic 04W 25V 1,000 μ F-M
C514	181P20505	C-Electrolytic 04W 50V 10 μ F-M	C956	142P02308	C-Ceramic F50V 0.01 μ F-Z
C516	189P07108	C-M-Plastic-PP 200V 0.47 μ F-J	C957	181P20208	C-Electrolytic 04W 16V 1,000 μ F-M
C517	189P08108	C-M-Plastic-PP 200V 1 μ F-J	C958	181P20108	C-Electrolytic 04W 10V 1,000 μ F-M
C519	172P08006	C-M-Plastic-PP 200V 0.1 μ F-K	C959	142P02308	C-Ceramic F50V 0.01 μ F-Z
C522	189P08104	C-M-Plastic-PP 200V 0.68 μ F-J	C963	154P25104	C-Ceramic R2KV 470pF-K
C773	142P02107	C-Ceramic B50V 4,700pF-K	C964	185D05803	C-Electrolytic H160V 330 μ F-M
C774	181P20207	C-Electrolytic 04W 16V 470 μ F-M	C966	142P01103	C-Ceramic B500V 1,000pF-K
C775	181P20205	C-Electrolytic 04W 50V 10 μ F-M	C968	181P19202	C-Electrolytic 04W 200V 2.2 μ F-M/Q
C901	189P03305	C-M-MF/PP-AC AC125V/250V 0.1 μ F-M (AUM-1371A · AUM-1371A(C))	C969	181P19202	C-Electrolytic 04W 200V 2.2 μ F-M/Q
C901	189P07604	C-M-Polyester-AC AC250V 0.47 μ F-M (EUM-1471A · EUM-1471A(B))	C970	142P01103	C-Ceramic B500V 1,000pF-K
C902	189P03304	C-M-MF/PP-AC AC125V/250V 0.047 μ F-M (AUM-1371A · AUM-1371A(C))	C971	154P25104	C-Ceramic R2KV 470pF-K
C902	189P08305	C-M-MF/P-AC AC250V 0.1 μ F-M (EUM-1471A(B))	C972	185D05404	C-Electrolytic H180V 330 μ F-M
C902	189P07604	C-M-Polyester-AC AC250V 0.47 μ F-M (EUM-1471A)	C974	142P01103	C-Ceramic B500V 1,000pF-K
C904	189P02705	C-Ceramic-AC F VA1 2,200pF-M	C975	172P08304	C-Plastic-PP 400V 0.047 μ F-K
C905	189P02705	C-Ceramic-AC F VA1 2,200pF-M	C976	154P25108	C-Ceramic R2KV 1,000 μ F-K
C906	189P02705	C-Ceramic-AC F VA1 2,200pF-M	C978	172P16101	C-TF 50V 0.068 μ F-J
C907	185D05301	C-Electrolytic H200V 470 μ F-Q (AUM-1371A · AUM-1371A(C))	C979	185D05803	C-Electrolytic H160V 330 μ F-M
C907	185D05703	C-Electrolytic H400V 330 μ F-M (EUM-1471A · EUM-1471A(B))	C980	181P19205	C-Electrolytic 04W 200V 10 μ F-M/Q
C908	181P18704	C-Electrolytic 04W 100V 10 μ F-M 105°C	C981	142P01103	C-Ceramic B500V 1,000pF-K
C909	181P18507	C-Electrolytic 04W 50V 2.2 μ F-M 105°C	C982	142P01201	C-Ceramic B500V 4,700pF-K
C910	142P02009	C-Ceramic B50V 1,000pF-K	C983	181P20506	C-Electrolytic 04W 50V 22 μ F-M
C912	172P16501	C-TF 50V 0.01 μ F-J (EUM-1471A · EUM-1471A(B))	C984	172P16509	C-TF 50V 0.047 μ F-J (AUM-1371A · AUM-1371A(C))
C912	172P16507	C-TF 50V 0.033 μ F-J (AUM-1371A · AUM-1371A(C))	VC601	202P10903	C-Trimmed 5.5pF~30pF (AUM-1371A · AUM-1371A(C))
C913	172P23107	C-Plastic-PP 400V 0.022 μ F-J	R2XS	109P05201	R-Fuse 1/4W 100 Ω -J
C914	154P25108	C-Ceramic R2KV 1,000pF-K	R2XT	109P05201	R-Fuse 1/4W 100 Ω -J
C931	189P02704	C-Ceramic-AC B VA1 1,000pF-K (AUM-1371A · AUM-1371A(C)) (EUM-1471A(B))	R415	103P37804	R-Fuse 1/4 2.2 Ω -J (EUM-1471A · EUM-1471A(B))
C932	189P02704	C-Ceramic-AC B VA1 1,000pF-K (AUM-1371A · AUM-1371A(C)) (EUM-1471A(B))	R514	103P37804	R-Fuse 1/4W 2.2 Ω -J
C933	189P02704	C-Ceramic-AC B VA1 1,000pF-K (AUM-1371A · AUM-1371A(C))	R515	103P46303	R-Metal 1/4W 2.2k Ω -F
C933	189P06703	C-Ceramic-AC F VA1 3,300pF-M (EUM-1471A(B))	R516	103P46309	R-Metal 1/4W 3.9k Ω -F
C933	189P02705	C-Ceramic-AC F VA1 2,200pF-M (EUM-1471A)	R6BA	109P05201	R-Fuse 1/4W 100 Ω -J
C934	189P02705	C-Ceramic-AC F VA1 2,200pF-M (EUM-1471A)	R6BB	109P05201	R-Fuse 1/4W 100 Ω -J
C934	189P02704	C-Ceramic-AC B VA1 1,000pF-K (AUM-1371A · AUM-1371A(C))	R6GA	109P05201	R-Fuse 1/4W 100 Ω -J
			R6GB	109P05201	R-Fuse 1/4W 100 Ω -J
			R6RA	109P05201	R-Fuse 1/4W 100 Ω -J
			R6RB	109P05201	R-Fuse 1/4W 100 Ω -J
			R6XN	103P43709	R-Fuse-Metal 2W 0.82 Ω -K (EUM-1471A · EUM-1471A(B))
			R736	103P41102	R-Carbon 1/4W 82 Ω -J
			R737	103P41102	R-Carbon 1/4W 82 Ω -J
			R738	103P41102	R-Carbon 1/4W 82 Ω -J
			R771	103P41205	R-Carbon 1/4W 1k Ω -J
			R780	103P41103	R-Carbon 1/4W 100 Ω -J
			R795	101P10303	R-Composition 1/2W 10k Ω -K
			R797	103P41409	R-Carbon 1/4W 100k Ω -J
			R798	103P41205	R-Carbon 1/4W 1k Ω -J
			R799	103P41505	R-Carbon 1/4W 330k Ω -J

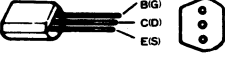
SYMBOL NO.	PART NO.	DESCRIPTION	SYMBOL NO.	PART NO.	DESCRIPTION
CAPACITORS & RESISTORS			VARIABLE RESISTORS		
R901	109D03109	R-Composition 1/2W 470kΩ-K	VR201	127C02007	Semifixed 1/5W B5kΩ±25%
R902	102P08301	R-Cement-Wire 10W 2.2Ω-K (AUM-1371A · AUM-1371A(C))	VR202	127C02101	Semifixed 1/5W B50kΩ±25%
R902	102P08704	R-Cement-Wire 10W 4.7Ω-K (EUM-1471A · EUM-1471A(B))	VR291	129C12701	Block (AUM-1371A · AUM-1371A(C))
R903	103P41505	R-Carbon 1/4W 330kΩ-J (AUM-1371A · AUM-1371A(C))	VR291	129C12703	Block (EUM-1471A · EUM-1471A(B))
R904	103P37008	R-Fuse 1/4W 39Ω-J	VR2B0	127C08001	Semifixed 1/5W B200Ω-M
R905	103C19007	R-Metal 3W 33Ω-J (AUM-1371A · AUM-1371A(C))	VR2R0	127C08001	Semifixed 1/5W B200Ω-M
R905	103C19009	R-Metal 3W 47Ω-J (EUM-1471A · EUM-1471A(B))	VR2X1	127C08008	Semifixed 1/5W B10kΩ-M
R906	103P41205	R-Metal 1/4W 1kΩ-J	VR401	127C08105	Semifixed 1/5W B500kΩ-M
R908	103C18007	R-Metal 2W 33Ω-J	VR402	127C08101	Semifixed 1/5W B50kΩ-M
R909	103C19406	R-Metal 3W 56kΩ-J	VR404	127C08008	Semifixed 1/5W B10kΩ-M
R910	103C19703	R-Metal 3W 0.27Ω-J (EUM-1471A · EUM-1471A(B))	VR406	127C08008	Semifixed 1/5W B10kΩ-M
R910	103C19702	R-Metal 3W 0.22Ω-J (AUM-1371A · AUM-1371A(C))	VR501	127C08007	Semifixed 1/5W B5kΩ-M
R911	103P41007	R-Carbon 1/4W 33Ω-J	VR502	127C08006	Semifixed 1/5W B3kΩ-M
R912	103P41504	R-Carbon 1/4W 270kΩ-J	VR601	127C09005	Semifixed 1/5W B2kΩ-M (EUM-1471A · EUM-1471A(B))
R913	103P41401	R-Carbon 1/4W 22kΩ-J	VR631	127C02007	Semifixed 1/5W B5kΩ±25% (EUM-1471A · EUM-1471A(B))
R914	103P37804	R-Fuse 1/4W 2.2Ω-J	VR691	129D11203	PCB 0.15W B5kΩ-15S CS
R915	103P41503	R-Carbon 1/4W 220kΩ-J (EUM-1471A · EUM-1471A(B))	VR692	129D11202	PCB 0.15W B5kΩ-15S
R916	103P41503	R-Carbon 1/4W 220kΩ-J (EUM-1471A · EUM-1471A(B))	VR6B0	127C08009	Semifixed 1/5W B20kΩ-M
R951	103C18003	R-Metal 2W 15Ω-J	VR6B2	127C03101	Semifixed 1/5W B50kΩ±25%
R953	103C18003	R-Metal 2W 15Ω-J	VR6G0	127C08009	Semifixed 1/5W B20kΩ-M
R954	103P41500	R-Carbon 1/4W 120kΩ-J	VR6G2	127C03101	Semifixed 1/5W B50kΩ±25%
R955	103C19403	R-Metal 3W 33kΩ-J	VR6R0	127C08009	Semifixed 1/5W B20kΩ-M
R956	103C18107	R-Metal 2W 220Ω-J	VR6R2	127C03101	Semifixed 1/5W B50kΩ±25%
R957	103C18900	R-Metal 2W 6.8Ω-J	VR6X1	127C08008	Semifixed 1/5W B10kΩ-M
R958	103C18706	R-Metal 2W 0.47Ω-J	VR6X2	127C08008	Semifixed 1/5W B10kΩ-M
R959	103P37209	R-Fuse 1/4W 2.2kΩ-J	VR701	127C02009	Semifixed 1/5W B20kΩ±25%
R960	103P41302	R-Carbon 1/4W 3.9kΩ-J	VR702	127C02009	Semifixed 1/5W B20kΩ±25%
R961	103P41302	R-Carbon 1/4W 3.9kΩ-J	VR703	127C02009	Semifixed 1/5W B20kΩ±25%
R962	103P37707	R-Fuse 1/4W 0.56Ω-K (AUM-1371A · AUM-1371A(C))	VR704	127C08007	Semifixed 1/5W B5kΩ-M
R962	283P03007	Fuse SSFR 2,500mA (EUM-1471A · EUM-1471A(B))	VR705	127C08103	Semifixed 1/5W B200kΩ-M
R963	103P37707	R-Fuse 1/4W 0.56Ω-K (AUM-1371A · AUM-1371A(C))	VR709	129D13005	Semifixed 1/4W B200kΩ-M
R963	283P03007	Puse SSFR 2,500mA (EUM-1471A · EUM-1471A(B))	VR770	129D13006	Semifixed 1/4W B300kΩ-M
R964	103P41008	R-Carbon 1/4W 39Ω-J	VR901	127C08102	Semifixed 1/5W B100kΩ-M
R965	103P37707	R-Fuse 1/4W 0.56Ω-K (AUM-1371A · AUM-1371A(C))	PRINTED CIRCUITS		
R966	103P37707	R-Fuse 1/4W 0.56Ω-K (AUM-1371A · AUM-1371A(C))		920A32501	PCB-MAIN (AUM-1371A · AUM-1371A(C))
R967	103P39801	R-Fuse 1/2W 1.2Ω-J (AUM-1371A · AUM-1371A(C))		920A32502	PCB-MAIN (EUM-1471A(B))
R967	283D06706	Fuse SSFR 2A (EUM-1471A · EUM-1471A(B))		920A32504	PCB-MAIN (EUM-1471A)
R991	109D03401	R-Cement-Wire 10W 10Ω-K		930B21401	PCB-RGB (AUM-1371A · AUM-1371(C))
				930B21402	PCB-RGB (EUM-1471A · EUM-1471A(B))
				930C17801	PCB-POWER (AUM-1371A · AUM-1371A(C))
				930C17802	PCB-POWER (EUM-1471A(B))
				930C17804	PCB-POWER (EUM-1471A)
				920D08701	PCB-CRT (AUM-1371A · AUM-1371A(C))
				920D08702	PCB-CRT (EUM-1471A · EUM-1471A(B))

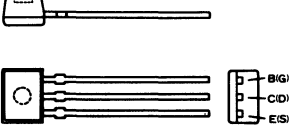
SYMBOL NO.	PART NO.	DESCRIPTION	SYMBOL NO.	PART NO.	DESCRIPTION
MISCELLANEOUS			CABINET-PARTS		
F901	283D02406	Fuse T3.15A (EUM-1471A · EUM-1471A(B))	641A08002		Cabinet-Bottom
F901	283D03805	Fuse S3.15A (AUM-1371A · AUM-1371A(C))	700A27601		Assy-Back-Cover (AUM-1371A)
K701	287P04701	Relay-Power G6B-1114P 12V DC	700C06308		Assy-Back-Cover (EUM-1471A)
K702	287P04701	Relay-Power G6B-1114P 12V DC	700C06405		Assy-Back-Cover (EUM-1471A(B))
K704	287P04701	Relay-Power G6B-1114P 12V DC	700C06406		Assy-Back-Cover (AUM-1371A(C))
S291	431C02901	SW-Slide	701A37401		Front-Panel
S292	431C04901	SW-Slide	761D49501		Knob-VR
S501	129P00709	VR-Channel-Plesetter BAND-SW	760B14604		Terminal-Board (AUM-1371A · AUM-1371A(C))
S691	129P00709	VR-Channel-Plesetter BAND-SW	760B14602		Terminal-Board (EUM-1471A(B))
	242C79509	AC-Power-Cord (EUM-1471A · EUM-1471A(B))	760B14607		Terminal-Board (EUM-1471A)
	242C89301	AC-Power-Cord (AUM-1371A · AUM-1371A(C))	761D49401		Button-Power
	242C98301	Cable (AUM-1371A · AUM-1371A(C)) (EUM-1471A)	930B24901		Unit-Cable-Case
	242C98001	Cable 9 Pin-IN	(572D08601)		Spring-Button
	242C98101	Cable 25 Pin-IN			
	338P01601	Convergence purity ring assembly			
	432P05303	SW-Push (SW-Power)			
	449C03109	Socket-CRT			
	451D04601	Power-Jack-3P (AUM-1371A · AUM-1371A(C))			
	641D75801	Wedge			
	451P03101	Inlet-Line-Filter (EUM-1471A · EUM-1471A(B))			
PACKING PARTS					
	802C76401	Packing-Case (AUM-1371A)			
	802C76402	Packing-Case (EUM-1471A)			
	802C76408	Packing-Case (AUM-1371A(C))			
	802C76409	Packing-Case (EUM-1471A(B))			
	803B54401	Cashion			
	829C04908	Packing-Sheet			
	831B02201	Packing-Bag			
	871C24004	IB-Monitor (AUM-1371A)			
	871C24005	IB-Monitor (EUM-1471A)			
	871C24104	IB-Monitor (AUM-1371A(C))			
	871C24105	IB-Monitor (EUM-1471A(B))			

	STR45111 STR59041
	DTC124F
	2SC2481
	2SC2229 2SC2236 2SA673* 2SC2274 2SC2230 2SC2482 2SA1320 2SA1321 2SB647A 2SA1371 2SC3467
	2SA673*
	2SC2603 2SC2724 2SA1115 2SK381
	2SC3598
	2SA1175 2SC2785 2SK656
	2SD1555

*2SA673 has two type of shapes as shown in above figure.

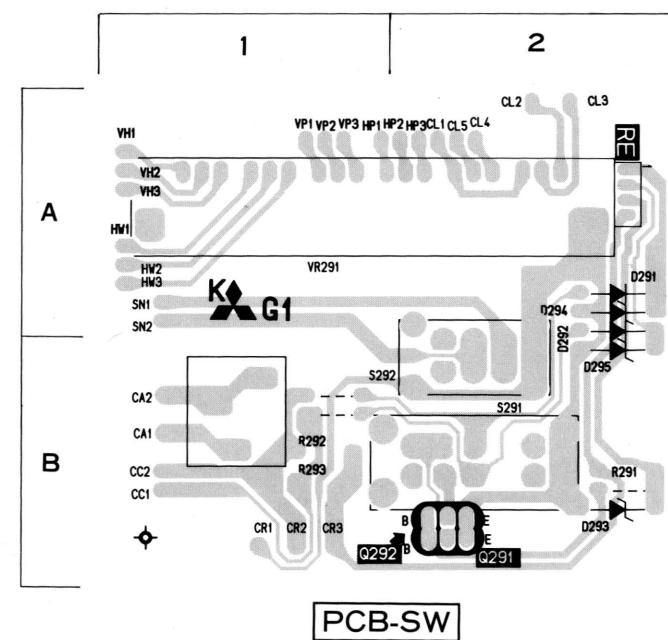
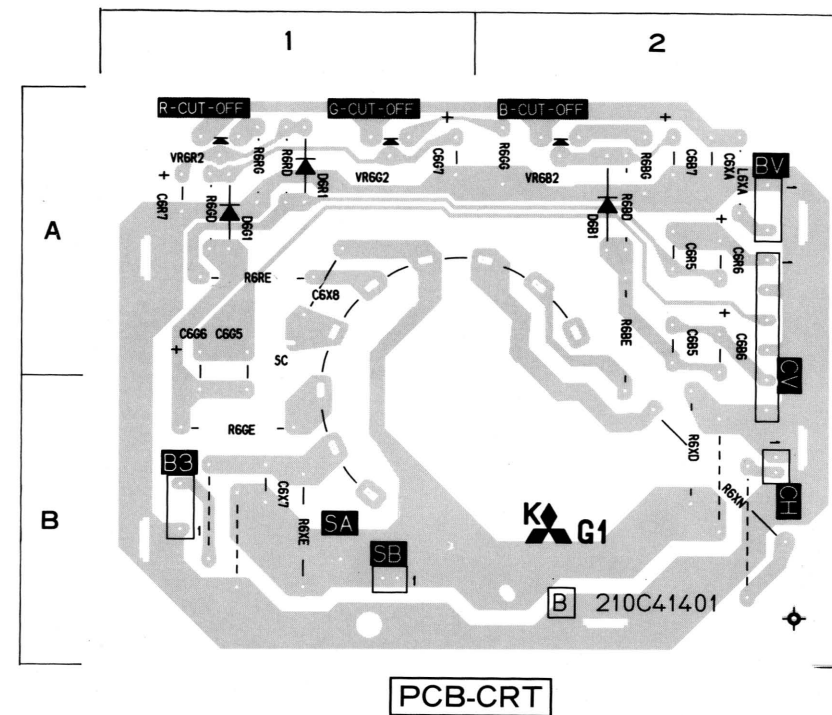
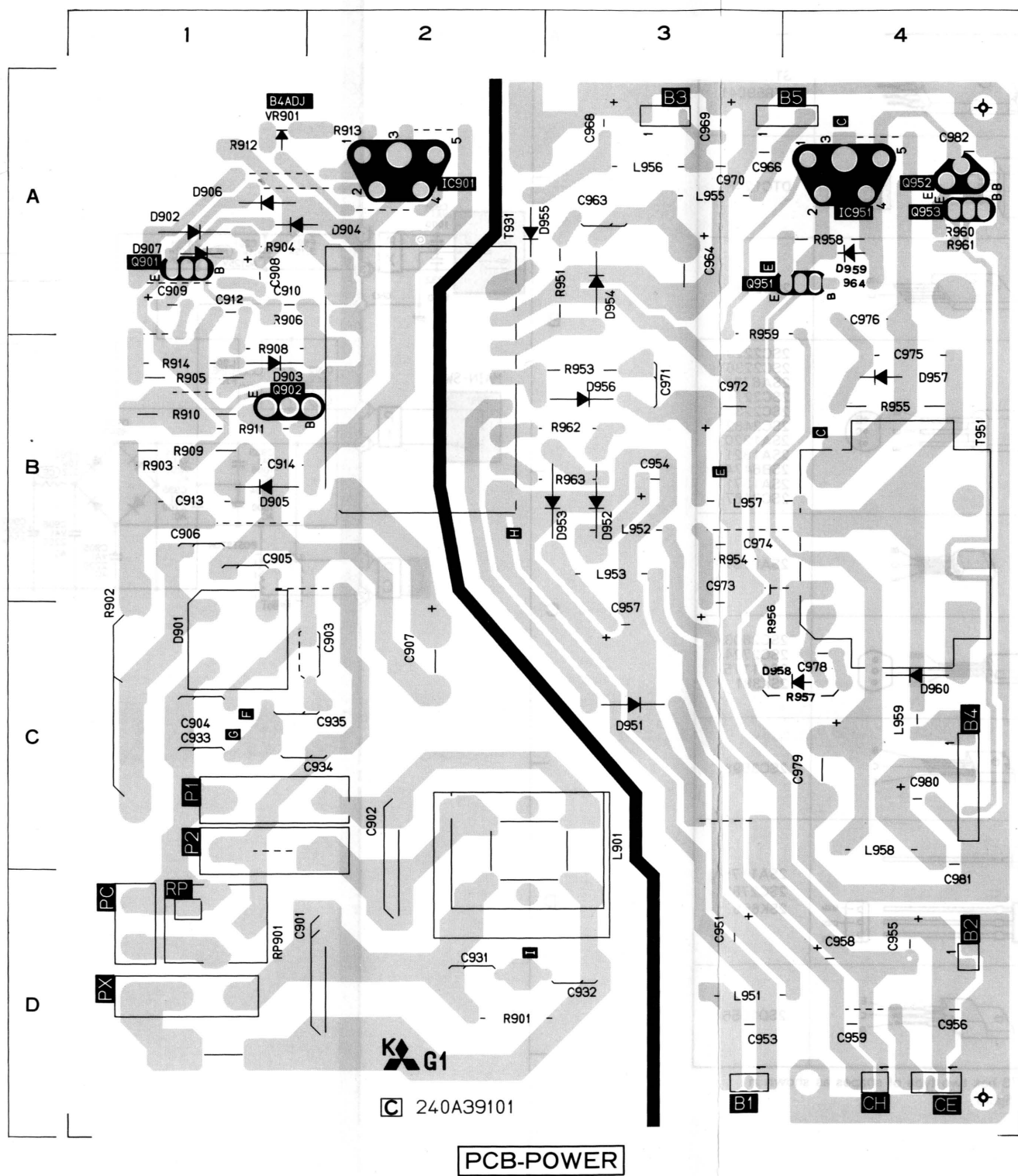

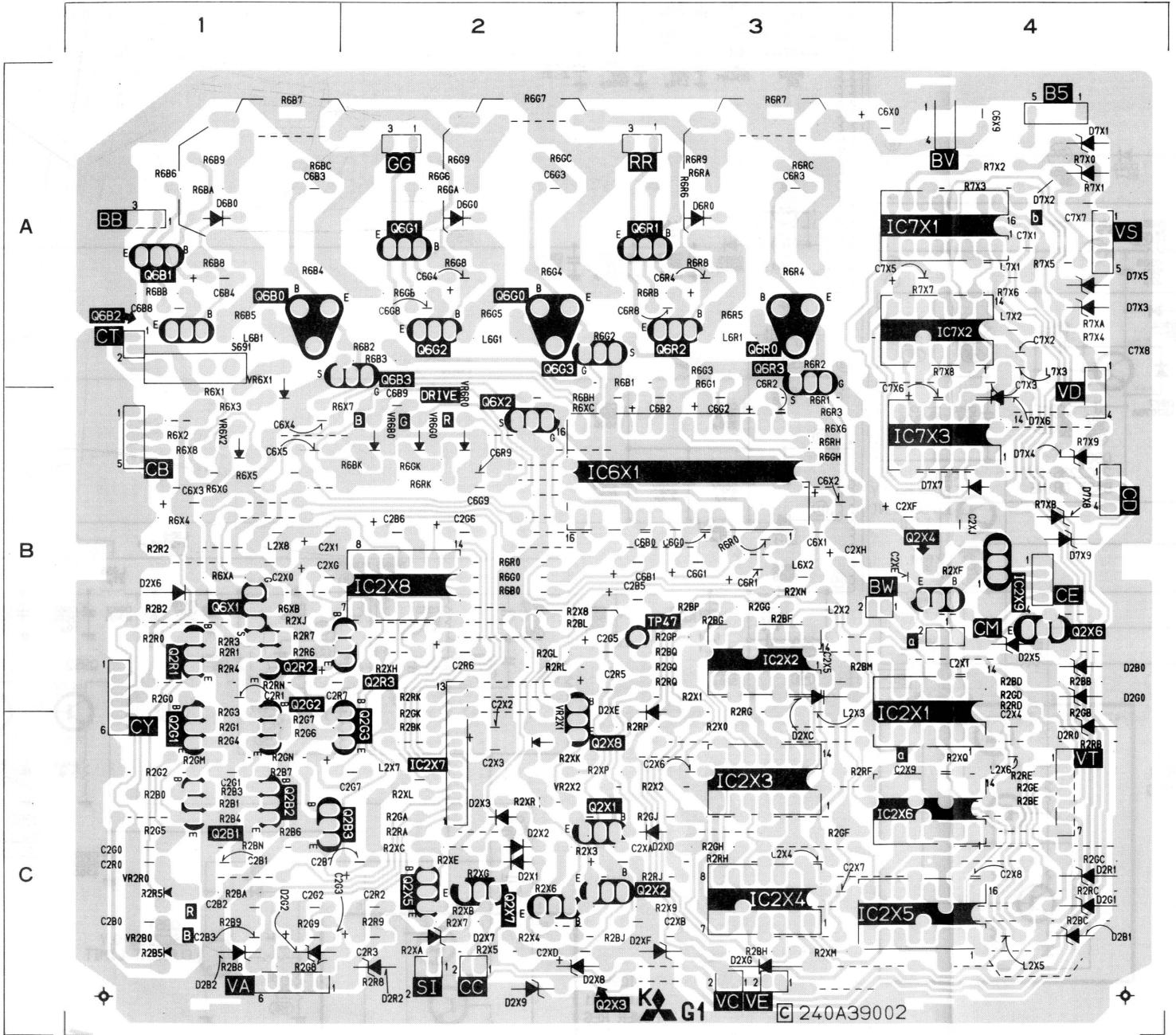

PCB-RGB

POWER-PCB

