



SC21-7868-1

File No. S34-36

IBM System/34
3270 Device Emulation Program Product
User's Guide

Program Number 5726-EM1



SC21-7868-1

File No. S34-36

IBM System/34
3270 Device Emulation Program Product
User's Guide

Program Number 5726-EM1

Second Edition (April 1983)

This major revision obsoletes SC21-7868-0 and Technical Newsletters SN21-8193 and SN21-8260. Additions were made to support the 5219 Printer. Changes or additions to the text are marked with a vertical line to the left of the change or addition.

This edition applies to release 9 modification 0 of the IBM System/34 3270 Device Emulation Program Product (5726-EM1), and to all subsequent releases unless otherwise indicated in new editions or technical newsletters.

Changes are periodically made to the information herein; these changes will be reported in technical newsletters or in new editions of this publication. References in this publication to IBM products, programs, or services do not imply that IBM intends to make these available in all countries in which IBM operates. Any reference to an IBM program product in this publication is not intended to state or imply that only IBM's program product may be used. Any functionally equivalent program may be used instead.

Use this publication only for the purposes stated in the *Preface*.

Publications are not stocked at the address below. Requests for copies of IBM publications and for technical information about the system should be made to your IBM representative or to the branch office serving your locality.

This publication could contain technical inaccuracies or typographical errors. Use the Reader's Comment Form at the back of this publication to make comments about this publication. If the form has been removed, address your comments to IBM Canada Ltd., Information Development, Department 849, 1150 Eglinton Avenue East, Don Mills, Ontario, Canada M3C 1H7. IBM may use and distribute whatever information you supply in any way it believes appropriate without incurring any obligation to you.

© Copyright International Business Machines Corporation 1980, 1983

This manual is intended for users of the System/34 Device Emulation Program Product. It contains information about operating device emulation as well as information of interest to host system programmers and System/34 programmers regarding setting up and running the 3270 Device Emulation Program Product.

This manual contains the following chapters:

- Chapter 1, *Introduction to Device Emulation*, which introduces the 3270 Device Emulation Program Product
- Chapter 2, *BSC 3270 Device Emulation*, which contains operating information and considerations for setting up and running the BSC support for the 3270 Device Emulation Program Product
- Chapter 3, *SNA 3270 Device Emulation*, which contains operating information and considerations for setting up and running the SNA support for the 3270 Device Emulation Program Product

Chapters 2 and 3 are divided into three parts: one for the terminal operator, one for the system operator, and one for the System/34 and host system programmers.

Note: The 3270 Device Emulation Program Product is not supported by the ideographic version of the SSP.

Prerequisite Publications

The following manual should be read, or the equivalent knowledge obtained, before using this manual:

- *IBM System/34 Introduction*, GC21-5153

Programmers should also read or be familiar with the following manuals:

- *IBM System/34 Planning Guide*, GC21-5154
- *IBM System/34 System Support Program Product Reference Manual*, SC21-5155
- *IBM System/34 Installation and Modification Reference Manual: Program Products and Physical Setup*, SC21-7689
- *IBM System/34 Interactive Communications Feature Reference Manual*, SC21-7751

Related Publications

- *IBM System/34 Displayed Messages Guide*, SC21-5159
- *IBM System/34 3270 Device Emulation Reference Card*, GX21-7858
- *IBM System/34 Operator's Guide*, SC21-5158

This page is intentionally left blank.

Contents

CHAPTER 1. INTRODUCTION TO DEVICE EMULATION	1-1	CHAPTER 3. SNA 3270 DEVICE EMULATION	3-1
CHAPTER 2. BSC 3270 DEVICE EMULATION	2-1	OPERATING SNA 3270 DEVICE EMULATION	3-2
OPERATING BSC 3270 DEVICE EMULATION	2-2	Signing On to the 5251 Display Station	3-2
Signing On to the 5251 Display Station	2-2	Signing On to SNA 3270 Device Emulation	3-3
Signing On to BSC 3270 Device Emulation	2-3	Signing On a Display Station	3-3
Signing On a Display Station	2-3	Signing On a Printer	3-4
Signing On a Printer	2-4	Handling Error Messages	3-5
Handling Error Messages	2-5	Operating Differences	3-5
Operating Differences	2-5	Keyboard Differences	3-5
Keyboard Differences	2-5	Display Screen Differences	3-9
Display Screen Differences	2-9	Printer Considerations	3-10
Printer Considerations	2-9	Signing Off SNA 3270 Device Emulation	3-11
Signing Off BSC 3270 Device Emulation	2-10	Signing Off the 5251 Display Station	3-11
Signing Off the 5251 Display Station	2-10	RUNNING SNA 3270 DEVICE EMULATION	3-12
RUNNING BSC 3270 DEVICE EMULATION	2-11	ALTERSDL and SPECIFY Procedures	3-12
ALTERBSC Procedure	2-11	ENABLE Procedure	3-12
ENABLE Procedure	2-11	DISABLE Procedure	3-14
DISABLE Procedure	2-13	SNA 3270 DEVICE EMULATION	
BSC 3270 DEVICE EMULATION CONSIDERATIONS	2-14	CONSIDERATIONS	3-15
System/34 Requirements	2-14	System/34 Requirements	3-15
Setting Up BSC 3270 Device Emulation	2-14	Setting Up SNA 3270 Device Emulation	3-15
Display 1.0 Subsystem Member Configuration	2-15	Display 1.0 Subsystem Member Configuration	3-16
Display 2.0 Common SSP-ICF Parameters for		Display 2.0 Common SSP-ICF Parameters for	
Each Subsystem	2-16	Each Subsystem	3-17
Display 3.0 General Subsystem Parameters	2-17	Display 3.0 General Subsystem Parameters	3-18
Display 4.0 Line Information for SSP-ICF		Display 4.0 Line Information for SSP-ICF	
Subsystem	2-18	Subsystem	3-19
Display 14.0 3270 Subsystem		Display 8.0 SNA General Subsystem	
General Parameters	2-19	Parameters	3-20
Display 15.0 3270 Subsystem		Display 9.1 SNA Upline/3270 Station	
Device Parameters	2-19	Parameters	3-22
Host Programming Considerations	2-22	Display 16.0 3270 Subsystem Device	
Data Transmission and Error Handling		Parameters	3-23
Considerations	2-23	VTAM/NCP Generation Considerations	3-25
Status Data	2-24	Host Programming Considerations	3-31
		Sense Data	3-32
		APPENDIX. PLANNING CHARTS	A-1
		INDEX	X-1

Figures

Figure 1-1.	Example Device Emulation Environment	1-2
Figure 1-2.	BSC 3270 Line Sharing Environment	1-3
Figure 1-3.	SNA 3270 Line Sharing Environment	1-3
Figure 2-1.	3277 Keyboard and 5251 Keyboard Placement	2-6
Figure 2-2.	Keyboard Functions Chart	2-7
Figure 3-1.	3277 Keyboard and 5251 Keyboard Placement	3-6
Figure 3-2.	Keyboard Functions Chart	3-7
Figure A-1.	BSC 3270 Subsystem Planning Chart	A-1
Figure A-2.	SNA 3270 Device Emulation Planning Chart	A-2

Displays

Display 1.0.	Subsystem Member Configuration	2-15
Display 2.0.	Common SSP-ICF Parameters for Each Subsystem	2-16
Display 3.0.	General Subsystem Parameters	2-17
Display 4.0.	Line Information for SSP-ICF Subsystem	2-18
Display 14.0.	3270 Subsystem General Parameters	2-19
Display 15.0.	3270 Subsystem Device Parameters	2-19
Display 1.0.	Subsystem Member Configuration	3-16
Display 2.0.	Common SSP-ICF Parameters for Each Subsystem	3-17
Display 3.0.	General Subsystem Parameters	3-18
Display 4.0.	Line Information for SSP-ICF Subsystem	3-19
Display 8.0.	SNA General Subsystem Parameters	3-20
Display 9.1.	SNA Upline/3270 Station Parameters	3-22
Display 16.0.	3270 Subsystem Device Parameters	3-23

Chapter 1. Introduction to Device Emulation

The 3270 Device Emulation Program Product allows the System/34 and locally attached display stations and printers to appear as a 3270 control unit with attached devices. Support is provided for attachment to both BSC and SNA/SDLC networks. When attached to a BSC 3270 network, the System/34 appears as a 3271 Model 2 cluster control unit with attached devices. When attached to an SNA/SDLC 3270 network, the System/34 appears as a 3274 Model 1C control unit with attached devices. Specific devices emulated are described in the BSC and SNA chapters later in this manual.

Host systems that support 3271 Model 2 or 3274 Model 1C control units on a multipoint network can have the System/34 with 3270 device emulation coresident on that network. Such host communications facilities include System/370 IMS/VS, CICS/VS, and TSO, and System/3 Model 15 CCP.

The 3270 device emulation support translates the 3270 data stream from and to the 5250 data stream, so no System/34 user coding is required to use device emulation. Many host systems have large investments in 3270 applications, and many, especially under BSC, support only a single device type on a communications line. The 3270 Device Emulation Program Product provides an easy means of introducing a programmable system into such a network. The end user at the System/34 can execute the same host applications as with a 3270. In addition, other applications can be developed at the System/34.

For example, Figure 1-1 illustrates a host system located in St. Louis, and remote locations that communicate with the host system from Dallas, Chicago, Kansas City, and Denver. All of the locations use common programs at the host system via 3270 devices. Besides the common programs, the Denver location uses certain programs and data not used by other locations. Denver can store and execute the programs on a System/34, and can use 3270 device emulation to access the common programs and data at the host system in St. Louis.

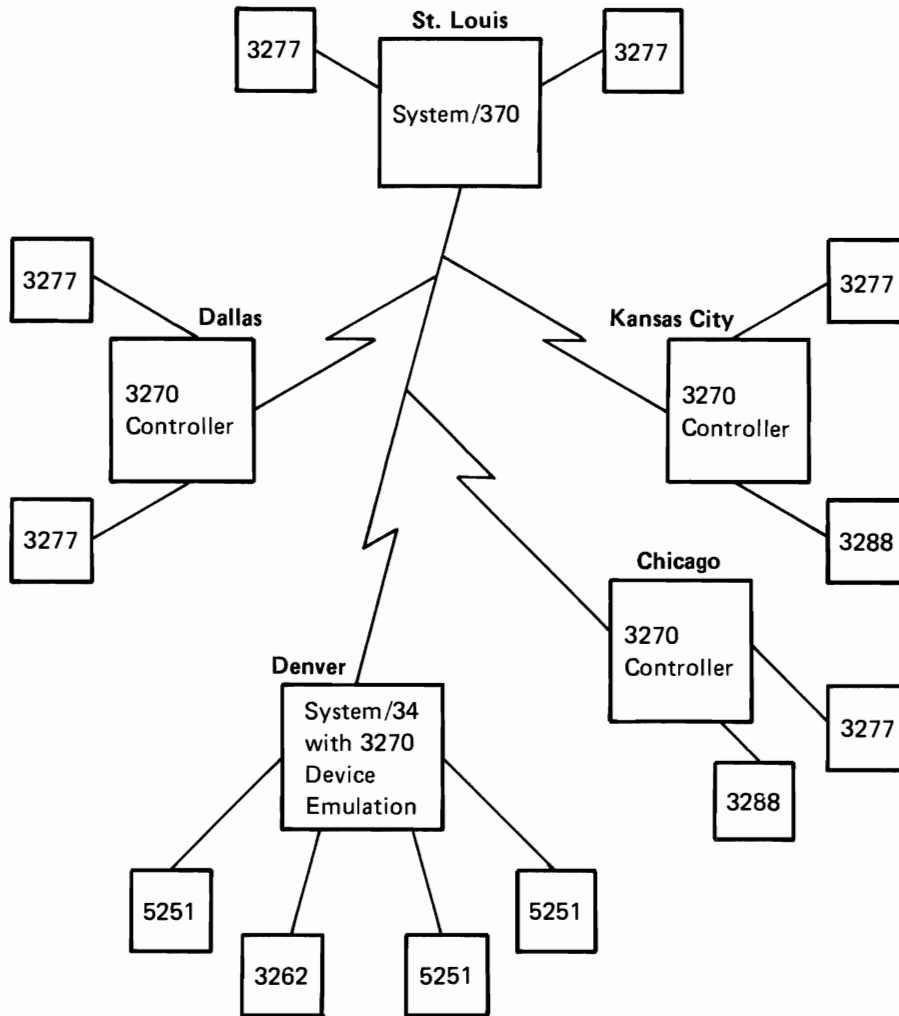

Figure 1-1. Example Device Emulation Environment

In addition to running existing 3270 applications, the System/34 can run new applications using the interactive communications feature on the same communications line concurrently with 3270 device emulation. If the communications is via BSC, the BSC 3270 support subsystem can be used for application programs that run concurrently with BSC 3270 device emulation (see Figure 1-2). If the communications is via SNA and SDLC, application programs using the SNA upline facility subsystem can share the communications line with SNA 3270 device emulation (see Figure 1-3).

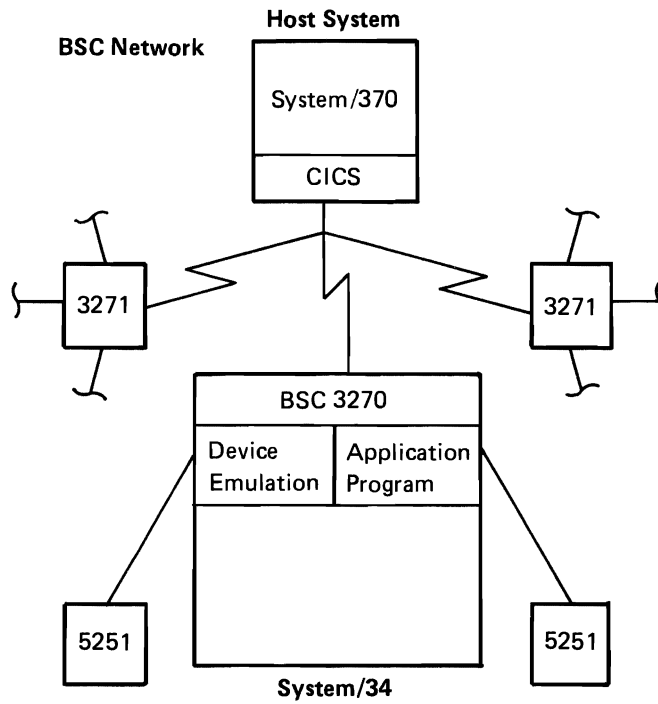

Figure 1-2. BSC 3270 Line Sharing Environment

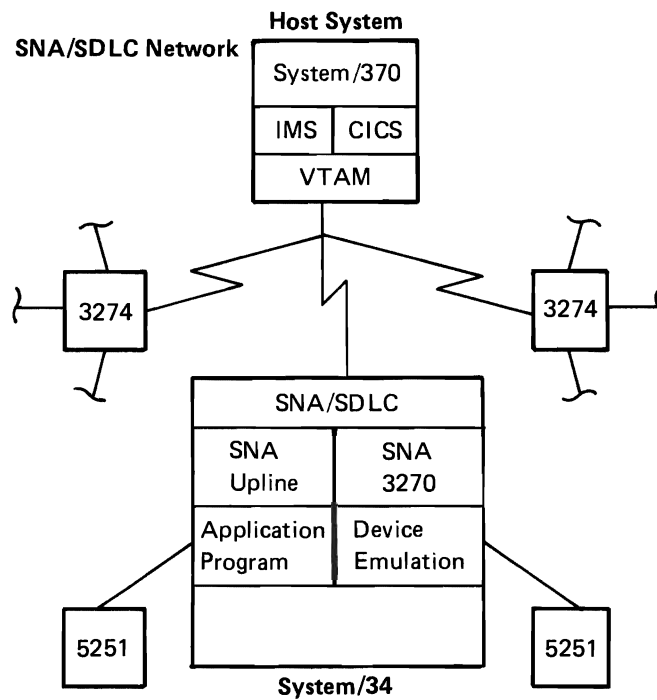

Figure 1-3. SNA 3270 Line Sharing Environment

BSC 3270 device emulation supports concurrent attachment of up to 32 sessions (device emulation and program-to-program) on one communications line. SNA 3270 device emulation supports attachment of up to 16 devices per communications line and up to four lines concurrently.

When a switched line connection is used with SNA 3270 device emulation, up to 32 remote locations can be defined for communications with the System/34. All locations can communicate with the System/34 on the same line, but only one location can use the line at a given time. All locations can be enabled at the same time, but only one will be communicated with at a time.

Only the EBCDIC typewriter keyboards and EBCDIC transmission are supported. Certain keys are in different locations on the 3277 keyboard and the 5251 keyboard. Function keys on the 3277 are mapped into the 5251 keyboard to provide the same function. For example, Field Mark, Erase Input, and PF keys do not exist on the 5251 keyboard, but the functions are supported using 5251 command and function keys. Details on how the keyboards compare are in subsequent chapters.

Use of the copy command (except the SNA host-initiated copy function) is not supported; however, the 5251 Print key can provide an equivalent function in many cases. The light pen and magnetic stripe reader are not supported.

The 3270 Device Emulation Program Product prepares and transmits appropriate status or sense information required by the host system. In addition, device emulation supports the basic error recovery features of the 3270 to help ensure the reliability of the communications network.

The System/34 3270 Device Emulation Program Product executes on all models of the System/34 having a minimum of 64 K bytes of main storage. System/34 3270 device emulation requires at least one communications adapter and Work Station Control Expansion Feature A or B.

The System/34 3270 Device Emulation Program Product is designed to run under control of the System/34 System Support Program Product and the Interactive Communications Feature.

Chapter 2. BSC 3270 Device Emulation

The BSC support of the 3270 Device Emulation Program Product, hereafter referred to as BSC 3270 device emulation, permits a System/34 to be attached to a BSC 3270 network and appear as a 3271 Model 2 cluster control unit to that network. The host system can be using IMS/VS, CICS/VS, TSO, or CCP. Locally attached display stations and printers, when signed on to BSC 3270 device emulation, emulate display stations and printers locally attached to the 3271 control unit. Specifically, the System/34 devices emulate the 3270 devices as follows:

System/34 Device	3270 Device
5251 Model 11 Display Station	3277 Model 2 Display Station
5211 Printer (all models)	3284, 3286, or 3288 Model 2 Printer
5256 Printer (all models)	3284, 3286, or 3288 Model 2 Printer
3262 Printer (all models)	3284, 3286, or 3288 Model 2 Printer
5224 Printer (all models)	3284, 3286, or 3288 Model 2 Printer
5225 Printer (all models except 11 and 12)	3284, 3286, or 3288 Model 2 Printer
5219 Printer (all models)	3284, 3286, or 3288 Model 2 Printer

The remainder of this chapter describes the support provided by BSC 3270 device emulation. The chapter is divided into three parts. The first is for the display station operator, and describes how to operate BSC 3270 device emulation. The second is for the System/34 system operator and System/34 programmer, and describes System/34 considerations for running BSC 3270 device emulation. The third is for the System/34 programmer and the host system programmer, and describes considerations for configuring, installing, and using BSC 3270 device emulation.

Operating BSC 3270 Device Emulation

BSC 3270 device emulation can be run from any locally attached 1920-character display station (5251 Model 11). The operator must perform the following tasks when using BSC 3270 device emulation:

- Signing on to the 5251 display station
- Signing on to BSC 3270 device emulation
- Handling error messages
- Identifying operating differences from 3270 devices, including:
 - Differences in keyboard appearances and function
 - Differences in display screens
 - Differences in printer functions
- Signing off BSC 3270 device emulation
- Signing off the 5251 display station

Each of these tasks is described in detail in the following sections.

SIGNING ON TO THE 5251 DISPLAY STATION

You must sign on to the 5251 display station before you can sign on to BSC 3270 device emulation. To sign on to the 5251 display station, do the following:

1. Hold down the shift key () while pressing the Sys Req/Attn key; then press the Enter/Rec Adv key. A sign-on display appears.
2. Key your user ID and password (if required) and any other appropriate information, and press the Enter/Rec Adv key.

If the user ID and password were valid, you are now signed on to the 5251 and ready to sign on to BSC 3270 device emulation. If the user ID or password was invalid, you must enter a correct ID and password before you can proceed.

SIGNING ON TO BSC 3270 DEVICE EMULATION

Signing on to BSC 3270 device emulation requires that you enter the EM3270 procedure command. Before you can enter this command, the system operator must have enabled a BSC 3270 subsystem configuration. If the subsystem has not been enabled, you will receive an error message (EMU-3101) indicating that the support is not active.

Signing On a Display Station

The format of the EM3270 procedure command for signing on a display station is:

EM3270 [work station id] , [ON] , [location name] , [YES/NO]

work station id: Specifies the logical ID of the display station to be signed on. If the display station being signed on is the one from which the command is entered, this parameter is not required. If the ID is that of another display station, that display station must be a data display station that is not currently in use or a command display station that is in standby mode.

ON: Specifies that you want to sign on to BSC 3270 device emulation. This parameter is not required because it defaults to ON.

location name: Specifies the location name associated with this session. The location name is defined during subsystem configuration, and refers to the name of the remote location with which communication is to take place. This parameter is not required.

YES/NO: Specifies whether diagnostic messages are to be displayed. YES specifies that messages are to be displayed, and is the default. NO specifies that messages are not to be displayed.

If you are signing on your own display station, you need to enter only EM3270.

Signing on a display station to BSC 3270 device emulation is the same as powering on a 3277 display station. You are then attached to the host system, and may have to enter host sign-on information before you can do other tasks.

Signing On a Printer

You can also sign a printer on to BSC 3270 device emulation. The format of the EM3270 procedure command for signing on a printer is:

```
EM3270 work station id, [ON] , [location name] , [  $\frac{YES}{NO}$  ] , [  $\frac{YES}{NO}$  ] , [priority]
```

work station id: Specifies the logical ID of the printer to be signed on. If the printer output for this printer is not being spooled, the printer must not currently be in use.

ON: Specifies that you want to sign on to BSC 3270 device emulation. This parameter is not required because it defaults to ON.

location name: Specifies the location name associated with this session. The location name is defined during subsystem configuration, and refers to the remote location with which communication is to take place. This parameter is not required.

YES/NO: Specifies whether output to the printer is to be spooled. YES specifies that output is to be spooled, and is the default. NO specifies that output is not to be spooled. If this printer is not using spooling, this parameter is ignored.

YES/NO: Specifies when spooled output should be printed. YES indicates that printing of the spooled output is deferred until the printer is signed off BSC 3270 device emulation; YES is the default. NO indicates that printing of the spooled output should not be deferred until the printer is signed off. If this printer is not using spooling, this parameter is ignored.

priority: Specifies the priority for spooled output. The priority is a decimal integer from 0 through 5, with 5 being highest priority (printed first), 1 being lowest priority, and 0 indicating that the output should be held until a RELEASE control command is entered. If this parameter is not specified, 1 is assumed. If this printer is not using spooling, this parameter is ignored.

After you have signed on to BSC 3270 device emulation, you are attached to the host system. Signing on to BSC 3270 device emulation is the equivalent of turning on the power at a 3284, 3286, or 3288 printer. You may have to enter host sign-on information before you can begin other tasks.

HANDLING ERROR MESSAGES

While signing on and operating BSC 3270 device emulation, you can get three kinds of System/34 error messages. All of these messages are explained in the *Displayed Messages Guide*.

Error messages pertaining explicitly to BSC 3270 device emulation are identified by EMU- followed by a 4-digit number. These messages are defined in the EMU section of the messages guide.

System errors are identified by SYS- followed by a 4-digit number. These messages are defined in the SYS section of the messages guide.



Flashing 4-digit numbers in the lower left corner of the display screen are keyboard errors. If you press the Help key when the number is flashing, a message appears at the bottom of the display. Keyboard errors are described in the KBD section of the messages guide.

OPERATING DIFFERENCES

The following sections describe the differences between System/34 devices and 3270 devices, specifically keyboard, display screens, and printer differences.

Keyboard Differences

The placement and function of keys differ between the 5251 keyboard and the 3277 keyboard. Figure 2-1 shows the comparative placement of keys on the 3277 and the 5251 keyboards. The numbers show the corresponding key on the other keyboard. The numbers also appear in Figure 2-2, which provides a summary of the functions of the 3277 keyboard and how they are performed on the 5251 keyboard. In the 5251 column of Figure 2-2, multiple keys are often shown. Where this occurs, the keys must be pressed in the order shown. When the shift key () is shown, hold down this key while

pressing the next key. For example, if the figure shows   

press and release the Cmd key; then hold down the shift key while pressing the  key.

3277 Keyboard

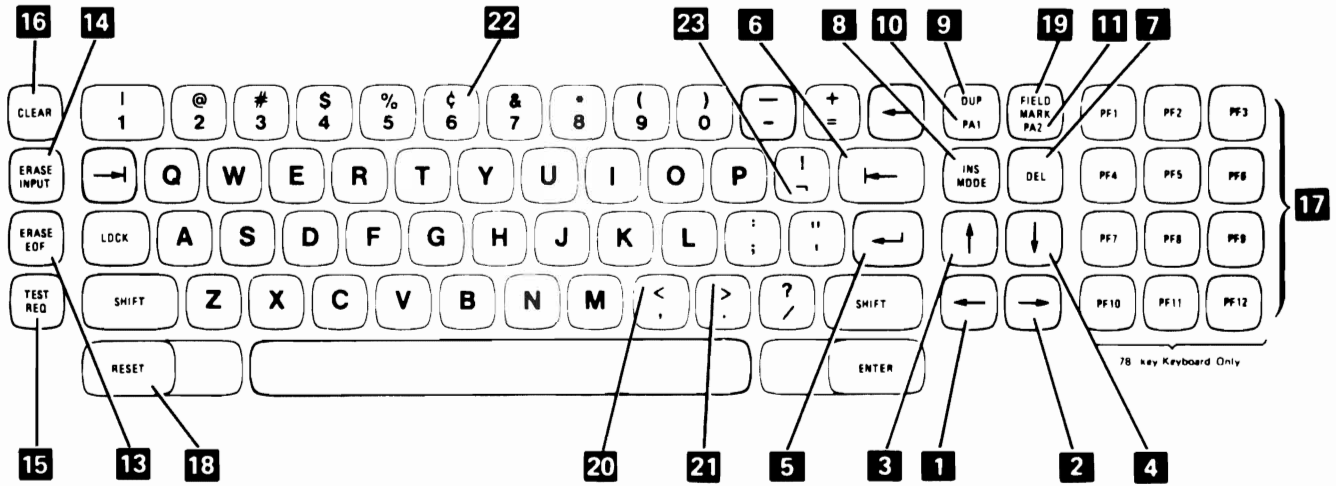

5251 Keyboard

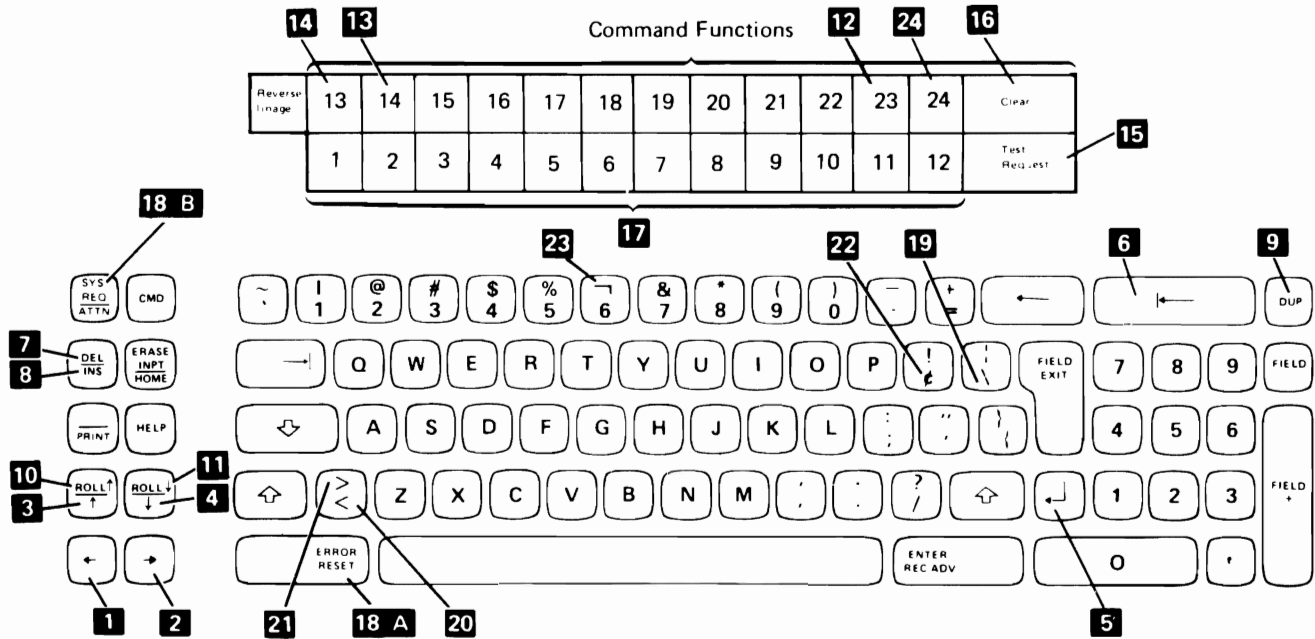

Note: The lower row of the template above the 5251 keyboard corresponds to the numeric keys on the top row of the 5251 keyboard after the Cmd key has been pressed. The upper row of the template corresponds to the numeric keys with the shift key held down after the Cmd key has been pressed.

Figure 2-1. 3277 Keyboard and 5251 Keyboard Placement

	3277 Key	Function	5251 Key
1		Cursor move left	
2		Cursor move right	
3		Cursor move up	
4		Cursor move down	
5		New line	
6		Back tab	
7	DEL	Delete	DEL INS
8	INS MODE	Insert	
9	SHIFT DUP PA1	Duplicate	
10	DUP PA1	Program attention 1	
11	FIELD MARK PA2	Program attention 2	
12	(See Note 1)	Program attention 3	
13	ERASE EOF	Erase to end of field	

	3277 Key	Function	5251 Key
14	ERASE INPUT	Erase input fields (See Note 2)	
15	TEST REQ	Test request	
16	CLEAR	Clear screen	
17	PF1 through PF12	Program function 1 - 12	through
18 A B	RESET	Reset	or (See Note 3)
19	SHIFT FIELD MARK PA2	Field mark	
20	SHIFT < ,	Less than	
21	SHIFT > .	Greater than	
22	SHIFT 6	Cent	
23	~	Logical not	
24	Power off	Sign off (See Note 4)	

Notes:

1. This key is only on the 3277 data entry keyboard.
2. Do not use the 5251 Erase Input key to perform the 3277 erase input function. The results will be unpredictable.
3. The 3277 Reset key unlocks a locked keyboard and resets insert mode. The 5251 Error Reset key resets insert mode. The 5251 Attn key unlocks a locked keyboard while device emulation is being used.
4. The 5251 command key 24 signs the display station off BSC 3270 device emulation.

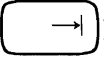
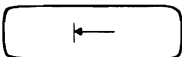



Figure 2-2. Keyboard Functions Chart

Command Key Functions: The following chart summarizes the 3277 functions available after you press the 5251 Cmd key:

Display Mode	13 Erase Input	14 Erase EOF	15	16	17	18	19	20	21	22	23 PA3	24 Sign Off	Clear
	1 PF1	2 PF2	3 PF3	4 PF4	5 PF5	6 PF6	7 PF7	8 PF8	9 PF9	10 PF10	11 PF11	12 PF12	Test Request



You can copy this information onto one of the blank templates on the *IBM 5251 Display Station Models 1 and 11/IBM 5252 Dual Display Station Keyboard Template, GX21-9266*.

Key Functions: The functions performed by the following 5251 keys differ from the corresponding 3277 functions:

- The 5251 tab (), back tab (), and new line () keys position the cursor to the home address whenever no input fields exist. The home address is always row 1 column 1 on the 3277, but varies on the 5251 according to where the cursor was positioned when the keyboard was unlocked.
- The 5251 Insert/Delete key () works on the entire input field regardless of whether the field continues on the next line.
- The 5251 Dup key fills the remainder of an input field with a special asterisk-overscore (). Disregard the additional characters that appear on the 5251 display screen; BSC 3270 device emulation recognizes that the Dup key was pressed, and performs the desired function.
- The 3277 Field Mark key is displayed on the 3277 as a semicolon (;) and is printed as an asterisk (*). On the 5251, it is displayed and printed as a backslash (\) character.
- The 5251 command key 14 performs the same function as the Erase EOF key on the 3277.
- Insert mode on the 5251 must be reset before you exit from an input field. If you press a command key or a roll key while in insert mode, an error message is issued. If you press the Enter/Rec Adv key while in insert mode, insert mode is reset and the enter function is performed.

CAUTION

Do not use the 5251 Field Exit key to perform the 3277 Erase EOF function; the results are unpredictable.

Do not use the 5251 Erase Input key to perform the 3277 erase input function. The display will indicate that the function was performed; however, unpredictable results will occur. If you accidentally press the 5251 Erase Input key, press command key 13 (  ), which performs the

device emulation erase input function. You can then continue with normal operation.

Display Screen Differences

When you are operating a 5251 using BSC 3270 device emulation, note the following differences between a 5251 and a 3277 display screen:

- You cannot key input into row 1 column 1 of the 5251.
- Filling in the last position of an input field does not always advance the cursor to the next input field. If the cursor does not automatically advance, it blinks in the last position of the input field. Press the Field Exit key to go to the next input field.

In addition to the above operating differences, the host system programmer should know some additional differences between the 5251 and 3277 display screens. For a description of these differences see *Host Programming Considerations* later in this chapter.

If you want a printed copy of the contents of a display, press the 5251 Print key. The printer for this display station does not need to be signed on to the BSC 3270 device emulation to perform this function.

Printer Considerations

Keep the following considerations in mind when using BSC 3270 device emulation to produce printed output:

- BSC 3270 device emulation output written to a spooled System/34 printer is not normally printed until the spool file is closed. If this is not satisfactory, you can specify NO for parameter 5 of the EM3270 procedure command. The spool file is closed when the printer is signed off BSC 3270 device emulation or when the BSC 3270 device emulation support is disabled.
- The 5256, 5211, 3262, 5224, and 5225 printers on the System/34 have a switch to set the number of printed lines per inch to 6 or 8. The printers they emulate print only at 6 lines per inch. To ensure that the output is formatted the same, set the System/34 printer to 6 lines per inch.
- The 5224 and 5225 printers allow a setting of 10 or 15 characters per inch in a printed line. The printers emulated print only 10 characters per inch. To ensure that the output is formatted the same, set the printer to 10 characters per inch.

SIGNING OFF BSC 3270 DEVICE EMULATION

Before signing any display station off device emulation, be sure to sign off the host system. Signing off device emulation is the equivalent of turning off the power at a 3277 display station or a 3284, 3288, or 3286 printer. Signing off BSC 3270 device emulation is done differently depending on the device being signed off.

To sign your own display station off BSC 3270 device emulation, press the Cmd key followed by the shift key and the  key (command key 24) or press the Attn key and select option 4.

To sign off a printer or a display station (except the one entering the EM3270 command), use the EM3270 command. The format of the EM3270 command for signing off BSC 3270 device emulation is:

EM3270 work station id,OFF

work station id: Specifies the logical ID of the display station or printer to be signed off. The display station entering the EM3270 command cannot be the one being signed off. The display station being signed off will return to standby mode.

OFF: Specifies that the device is to be signed off BSC 3270 device emulation.

SIGNING OFF THE 5251 DISPLAY STATION

After you have signed off BSC 3270 device emulation, you can sign off the 5251 display station. To sign off the 5251, key OFF and press the Enter/Rec Adv key. The sign-on display appears, and the display station is ready for its next user.

Running BSC 3270 Device Emulation

ALTERBSC PROCEDURE

When preparing to run BSC 3270 device emulation, you might want to change some of the items configured for the communications line. To change the items, run the ALTERBSC procedure. Before running the procedure, you can check the configuration by using the STATUS COMM operator command. A separate configuration record exists for each command display station. BSC 3270 device emulation uses the configuration record of the system console, so be sure to enter the STATUS command and run the ALTERBSC procedure from the system console.

The following items can be changed by the ALTERBSC procedure:

- Modem rate (half or full)
- World Trade answer tone
- IBM modem
- Switched network backup
- Clocking
- Error retry count

For additional information about the ALTERBSC procedure, see the *SSP Reference Manual*.

ENABLE PROCEDURE

Before devices can sign on to BSC 3270 device emulation, the ENABLE procedure must be run from the system console. The ENABLE procedure performs the following functions for BSC 3270 device emulation:

- Determines whether the line requested is available.
- Loads and attaches the BSC 3270 subsystem if it is not already active.
- Loads and attaches the BSC 3270 interrupt handler.
- Assigns storage for required data areas and buffers.

Note: If a subsystem is enabled, procedures that require a dedicated system, such as COMPRESS, cannot be run.

The format of the ENABLE procedure command is:

ENABLE name, #LIBRARY, line number, SHOW
library name, NOSHOW

name: Specifies the member name of the subsystem configuration to be enabled.

library name: Specifies the name of the library that contains the specified subsystem configuration. The default is #LIBRARY.

line number: Specifies the number of the communications line for which this subsystem is to be enabled.

Note: If the System/34 is to communicate on a nonswitched multipoint line, the line selected here must be specified as a point-to-point nonswitched. Specifying the LINE parameter as P on the OVERRIDE command accomplishes this.

SHOW/NOSHOW: Specifies whether subsystem configuration parameters are to be displayed before the subsystem is enabled. NOSHOW is the default. If SHOW is specified, they are displayed, and some of the configuration parameters can be changed. You can use the SHOW parameter to change the following:

- SSP-ICF common queue space (if this is the first subsystem enabled)
- SSP-ICF subsystem queue space
- User block size
- Swappability of the subsystem
- Control unit address
- Line buffer size
- Delay count
- Retry count

After being enabled, the BSC 3270 support subsystem begins to monitor the communications line. The subsystem responds to BSC control sequences as a 3271 Model 2 cluster control unit would respond if all its devices were powered off.

After the ENABLE procedure has been run, the EM3270 procedure can be used to sign devices on to BSC 3270 device emulation. This is analogous to powering on a 3277 display station or a printer.

DISABLE PROCEDURE

To de-activate BSC 3270 device emulation, the DISABLE procedure must be run from the system console. When a disable is performed, BSC 3270 device emulation waits for the host system to de-activate the device addresses. When the last device is de-activated, the host system sees the System/34 as a 3271 Model 2 cluster control unit that has been powered off. When a disable is requested, the following functions are performed:

- If no active sessions are using the BSC 3270 subsystem, the configuration is disabled, and the main storage being used is freed. The BSC 3270 support subsystem and the BSC 3270 interrupt handler are terminated.
- If devices are signed on to BSC 3270 device emulation, a message is issued to the system operator with the following options:
 - Hold the disable. New sessions are prevented from being started and, when all sessions are completed, a normal disable occurs.
 - Retry the disable. Check again for any active sessions.
 - Cancel active sessions and disable. Active sessions are immediately terminated, and the disable is performed.
 - Ignore the disable request. The DISABLE procedure is canceled and must be run again when a disable is desired.
- If a disable is already being held, a message is issued to the system operator with the following options:
 - Force a disable of all subsystems using this line; do not wait for the host to terminate the line.
 - Ignore the disable request. The DISABLE procedure is canceled and must be run again when a disable is desired.

The format of the DISABLE procedure command is:

DISABLE name

name: Specifies the member name of the subsystem configuration to be disabled.

BSC 3270 Device Emulation Considerations

SYSTEM/34 REQUIREMENTS

The System/34 requires a minimum of 64 K bytes of main storage to support BSC 3270 device emulation. A larger storage size is recommended if multiple devices are to be attached concurrently. BSC 3270 device emulation support requires 8 K bytes of nonswappable main storage and 8 K bytes of swappable main storage. Each display station attached to BSC 3270 device emulation requires 16 K bytes of swappable main storage (not including SSP-ICF support or common and subsystem queue space). Each printer attached to BSC 3270 device emulation requires an additional 8 K bytes of swappable main storage.

Work station controller expansion feature A or B is required on the System/34.

BSC 3270 device emulation requires that the BSC microcode be configured for a multipoint line. The System/34 BSC microcode and the 3271 Model 2 cluster control unit have slightly different capabilities for transmitting and receiving data on the communications line.

The 3270 Device Emulation Program Product is designed to run under control of the System/34 System Support Program Product. The Interactive Communications Feature (SSP-ICF), a separately priced feature, must also be installed and active on the system. Specifically, the BSC 3270 support subsystem must be configured and active to run BSC 3270 device emulation.

SETTING UP BSC 3270 DEVICE EMULATION

The SSP procedures CNFIGSSP and INSTALL are used to include the interactive communications and BSC 3270 device emulation support on the System/34. The general interactive communications support is included by requesting it on the appropriate CNFIGSSP prompt. The 3270 subsystem support is then copied to the BSC 3270 device emulation library (#EM71LIB) by taking the appropriate responses to the INSTALL procedure prompts. The CNFIGSSP and INSTALL procedures, with their displays and related responses, are described in the *Installation/Modification Reference Manual*.

After BSC 3270 device emulation has been installed, the CNFIGICF procedure is used to tailor the subsystem support to an existing or proposed network. The operation of the CNFIGICF procedure is also explained in the *Installation/Modification Reference Manual*. Before running the CNFIGICF procedure, however, you should fill out a planning chart for each subsystem that you want to define. Copies of the planning chart for BSC 3270 device emulation are available at the end of this manual and in the *Installation/Modification Reference Manual*. The following sections explain how to fill out the planning chart for BSC 3270 device emulation.

Display 1.0 Subsystem Member Configuration

1.0	Subsystem Member Configuration	
1.	Subsystem configuration member name (8 characters)	— — — — — — — —
2.	Subsystem library name (8 characters)	— — — — — — — —
	Select:	
	1. Create new member	4. Delete a member
	2. Edit existing member	5. Review a member
	3. Create new member from existing member	
3.	Enter selection: _____	
4.	Existing member name:	— — — — — — — —
5.	Existing member library name:	— — — — — — — —

Subsystem configuration member name: Specify a name for this configuration of the subsystem. The name is used to store the member in a library, and is referenced in the ENABLE and DISABLE procedures.

Subsystem library name: Specify the name of the library in which the configuration is stored or is to be stored. Although the default is #LIBRARY, you should store the configuration in a user library.

Enter selection: Specify one of the five options: (1) create a new member, (2) edit an existing member, (3) create a new member from an existing member, (4) delete a member, or (5) review a member without changing it.

Existing member name: This prompt appears if option 3 was selected. Specify the name of the existing subsystem configuration member that is to be used to create the new member. The existing member remains unchanged.

Existing member library name: This prompt appears if option 3 was selected. Specify the library name where the existing member resides.

Display 2.0 Common SSP-ICF Parameters for Each Subsystem

2.0 Common SSP-ICF Parameters for Each Subsystem

1. SSP-ICF common queue space: (2 - 42 K) — —
2. Define the subsystem type: — 8
 - 1 Intra
 - 2 BSC IMS/IRSS
 - 3 BSCEL
 - 4 BSC CICS
 - 5 BSC CCP
 - 6 SNA Upline
 - 7 SNA Peer
 - 8 BSC 3270
 - 9 SNA 3270
 - 10 Finance

SSP-ICF common queue space: Specify the size, in multiples of 2 K bytes, of the common queue space. The common queue space requirements for the 3270 subsystem are:

$$C = 104A + 1264$$

where

C = number of bytes required for common queue space

A = number of acquired program-to-program concurrent sessions (This does not include devices signed on to BSC 3270 device emulation.)

The common queue space value specified for the first subsystem that is enabled becomes the size of the common queue space. Be sure that the value specified for common queue space size takes into account the requirements of any other subsystem that might be active concurrently.

The size of the common queue space plus the subsystem queue space of the enabled 3270 subsystem cannot exceed 42 K bytes.

The default common queue space size is 4 K bytes.

Define the subsystem type: Specify an 8 for the BSC 3270 subsystem.

Display 3.0 General Subsystem Parameters

3.0 General Subsystem Parameters

1.	Location name:	(8 characters)	— — — — — — — —
2.	Subsystem queue space:	(0-40 K)	— —
3.	Subsystem support swappable:	(0-No 1-Yes)	—
4.	Maximum user record length:	(0-4075)	— — — —

Location name: Specify the 8-character name for the location associated with this configuration. The location name is used in some of the displayed message texts, and must be coded on the SESSION OCL statement. The default is the subsystem configuration member name. The location name refers to the name of the location with which communications is to take place.

Subsystem queue space: Specify the size, in multiples of 2 K bytes, of the subsystem queue space. The subsystem queue space requirements for the 3270 subsystem are:

$$S = 2L + 2AR + C + 8$$

where

S = number of bytes required for the subsystem queue space

L = line buffer length

A = maximum number of program-to-program sessions that will be active concurrently (This does not include devices attached to BSC 3270 device emulation.)

R = maximum record length for program-to-program sessions (If BSC 3270 device emulation is to be used without program-to-program sessions, this value should be 0.)

C = 0 if maximum record length is 0, else 256

If no other subsystems will be active concurrently, these requirements should be added to the common queue space requirements, and the subsystem queue space should be 0.

The size of the common queue space plus the subsystem queue space of the BSC 3270 subsystem cannot exceed 42 K bytes.

The default subsystem queue space size is 4 K bytes.

Subsystem support swappable: Specify whether you want the subsystem to be swappable. Consider the total system performance, the size of the subsystem, and the amount of user main storage when determining whether you want the subsystem swappable. The 3270 subsystem requires 8 K bytes of main storage. The subsystem should be specified as swappable if the subsystem will be used for 3270 device emulation only.

Maximum user record length: Specify the maximum record length (0 through 4075 bytes) to be sent or received by any System/34 application program using this subsystem configuration. This length excludes BSC control characters and 3270 device control characters (if DATAID was specified), but includes any messages sent by the host system (CCP messages, for example). If the subsystem will be used only for 3270 device emulation, the maximum record length should be set to 0. The default is 1024 bytes.

Display 4.0 Line Information for SSP-ICF Subsystem

4.0	Line Information for SSP-ICF Subsystem
------------	---

2.	Local station address:	(2 hex)	--
----	------------------------	---------	----

Local station address: Specify the System/34 multipoint line address for this configuration. The local station address for the System/34 must correspond to the address configured for the System/34 during host system configuration. (See the chart at the end of this section for the relationship of the local station address to the host configurations.) The following are valid local station addresses: 40, C2, C3, C4, C5, C6, C7, C8, C9, 4A, 4B, 4C, 4D, 4E, 4F, D1, D2, D3, D4, D5, D6, D7, D8, D9, 5A, 5B, 5C, 5D, 5E, and 5F.

Note: The line used must be type P, nonswitched point-to-point.

Display 14.0 3270 Subsystem General Parameters

14.0 3270 Subsystem General Parameters

- | | | | |
|----|-------------------|------------|---------|
| 1. | Line buffer size: | (256-4096) | _ _ _ _ |
| 2. | Delay count: | (0-255) | _ _ _ |

Line buffer size: Specify, in decimal, the number of bytes in the line buffer. The line buffer size should be greater than or equal to the largest transmission that will be received from the host system, up to a maximum of 4096 bytes. The size includes any BSC control characters and 3270 device control characters, as well as any messages sent by the host system (CCP messages, for example). The default size of 2040 bytes should be changed only if queue space limitations necessitate a decrease, or if line buffer overflows occur (necessitating an increase).

Delay count: Specify the number of times the BSC interrupt handler should negatively respond before terminating an operation. A delay count greater than zero should be specified only if return codes that indicate the delay count was exceeded (8399 or 839A) are received intermittently because of high System/34 processor overload. The delay count should not be increased if the return codes are received in the following situations:

- A display station using 3270 BSC device emulation experiences an error or is powered off.
- System/34 programs regularly experience one or both return codes. Increasing the delay count in this situation would severely degrade the performance of the entire 3270 network.

Display 15.0 3270 Subsystem Device Parameters

15.0 3270 Subsystem Device Parameters

- | | | |
|----|-----------------------------|---|
| 1. | Device address | 40 C1 C2 C3 C4 C5 C6 C7 C8 C9 4A 4B 4C 4D 4E 4F |
| 2. | Device type*(1, 2, 3, or 5) | _ _ _ _ _ |
| 3. | S/34 logical ID | _ _ _ _ _ |
| 4. | Lower case (0-No 1-Yes) | _ _ _ _ _ |
| | | |
| 5. | Device address | 50 D1 D2 D3 D4 D5 D6 D7 D8 D9 5A 5B 5C 5D 5E 5F |
| 6. | Device type*(1, 2, 3, or 5) | _ _ _ _ _ |
| 7. | S/34 logical ID | _ _ _ _ _ |
| 8. | Lower case (0-No 1-Yes) | _ _ _ _ _ |

* 1 - Program 2-3277 Display 3-3277 with Numeric Lock 5-3288 Printer

Device address: Each address represents one of the allowable device addresses for a 3270 session. The device address corresponds to values specified during host system generation. (See the chart at the end of this section for the relationship of the device addresses to the host system configuration.) To specify these addresses for a particular session, use the DEVADDR parameter on the SESSION OCL statement.

Device type: Specify the type of device that will be attached to the device address. Possible values and their meanings are:

- | | |
|-------|--|
| blank | Undefined. The address will not be used for this configuration. |
| 1 | Program. The device address will be used to address an application program on the System/34. Only addresses with device type 1 can be acquired. |
| 2 | 3277 Display. The device address will be used to address a display station. The 5251 display station will emulate a 3277 display station using the 3270 Device Emulation Program Product. |
| 3 | 3277 with Numeric Lock. The device address will be used to address a display station. The 5251 display station will emulate a 3277 display station with the Numeric Lock feature, using the 3270 Device Emulation Program Product. |
| 5 | 3288 Printer. The device address will be used to address a printer. The printer on the System/34 will emulate a 3288 line printer using the 3270 Device Emulation Program Product. |

S/34 logical ID: Do not specify this parameter for device type 1 (program). Specify the logical ID of the work station to be used for the device address. If the logical ID is specified, it must match the logical ID of a local display station or a local printer. The device address is reserved for use exclusively by that System/34 work station. A System/34 logical ID can appear only once in a configuration. If no logical ID is specified with a device address, any appropriate device type can use the device address on a first-come, first-served basis.

Lowercase: Do not specify this parameter for device types 1 (program) or 5 (printer). Specify whether lowercase is allowed on the display station. Specify 0 (no) or 1 (yes). If lowercase is not specified, all lowercase characters are displayed and sent to the host system as uppercase characters.

The following figures show the relationship of System/34 local station addresses and device addresses to those specified during host system configuration.

IMS/VS Stage 1 Generation Input for BTAM Terminals

```

LINEGRP DDNAME=DD3270R,UNITYPE=3270,CODE=EBCDIC
LINE ADDR=033
CTLUNIT ADDR=40,MODEL=2
TERMINAL ADDR=40,FEAT=(PFK,NOCD,NOPEN),MODEL=2,UNIT=3277,
  OPTIONS=(TRANRESP,NOCOPY,PAGDEL)
NAME BB4040D
TERMINAL ADDR=C1,FEAT=(PFK,NOCD,NOPEN),MODEL=2,UNIT=3277,
  OPTIONS=(TRANRESP,NOCOPY,PAGDEL)
NAME BB40C1D
  
```

System/34 Local Station Address

System/34 Device Addresses

CICS/VS Terminal Control Table Input for BTAM Terminals

```

R3270A  DFHTCT TYPE=SDSCI,
        DEVICE=3277,
        DSCNAME=DD3270A,
        BSCODE=EBCDIC,
        ERROPT=E
RL3270A DFTRMLST AUTOWLST,(40407F7F2D,3737373737)
AA77A   DFTRMLST OPENLST,(606040402D)
AA77B   DFTRMLST OPENLST,(6060C1C12D)
  
```

System/34 Local Station Address

System/34 Device Addresses

NCP Stage 1 Generation Input (for IMS/VS or CICS/VS VTAM Terminals)

```

CLB     CLUSTER CUTYPE=3271,
        ISTATUS=INACTIVE,
        LOGAPPL=NETSOL,
        TERM=3277,
        GPOLL=C2C27F7F,
        XMITLIM=1
TB1     TERMINAL ADDR=E2E24040,
        ISTATUS=ACTIVE,
        POLL=C2C24040
TB2     TERMINAL ADDR=E2E2C1C1,
        ISTATUS=ACTIVE,
        POLL=C2C2C1C1
  
```

System/34 Local Station Address

System/34 Device Addresses

CCP Assignment Set Input

```

// BSCATERM TERMID=40,TYPE=3277M2,ATTRID=2,COMMAND=YES,
//   ADDRCHAR-*60604040*,POLLCHAR-*40404040*
// BSCATERM TERMID=C1,TYPE=3277M2,ATTRID=2,COMMAND=YES,
//   ADDRCHAR-*6060C1C1*,POLLCHAR-*4040C1C1*
  
```

System/34 Device Addresses

System/34 Local Station Address

HOST PROGRAMMING CONSIDERATIONS

The implementation of several functions on the System/34 is different from that on the host system. The following paragraphs describe these differences. Some changes to host system programming may be required before BSC 3270 device emulation is run, if any of these functions are currently used.

No 5251 display can contain more than 127 input fields.

No field on the 5251 can wrap the screen (continue from row 24 column 80 to row 1 column 1). If the 5251 displays a 3277 screen format that wraps the screen, the character at row 1 column 1 is replaced with an input field attribute. If the starting cursor position is row 1 column 1, it is moved to row 1 column 2. Data is returned to the host as if row 1 column 1 contained a null character.

If the 5251 Display Station is emulating a 3277 Display Station with the Numeric Lock feature, a comma, space, and plus sign can also be entered into a numeric field.

BSC 3270 device emulation emulates an unformatted 3277 display (one without attributes) by replacing the character at row 1 column 1 with an input field attribute. This allows the operator to key data into the remainder of the display. If the starting cursor position is row 1 column 1, it is moved to row 1 column 2. Data is returned to the host as if row 1 column 1 contained a null character.

A 3277 modified field of length zero (that is, an attribute with the modified data tag followed immediately by another attribute) is not supported by the 5251.

The control unit addresses C1/61 and 50/F0 are not supported by the System/34.

Data Transmission and Error Handling Considerations

In slave mode (selected and ready to receive), the 3271 waits indefinitely for the host's transmission. The System/34 waits three times the delay count in seconds (specified during configuration) before abnormally terminating slave mode.

In master mode (polled and transmitting data), the 3271 sends ENQs whenever the host does not respond. The System/34 sends ENQ until the retry count expires before abnormally terminating master mode.

When conditions on the System/34 prevent the 3270 Device Emulation program from executing after slave or master mode has been established, the 3270 BSC interrupt handler sends NAK until the delay count expires (in slave mode) or sends STX-substitution character-ENQ up to the delay count (in master mode). Conditions such as these could result from work station errors or System/34 processing unit overload.

During a read buffer or read modified operation, the BSC 3271 control unit replaces any byte that has bad parity with a substitution character, and a data check status condition is recorded. The System/34 does not send back the data in this case. Instead, it indicates an error condition and sets status information.

The 3271 Model 2 cluster control unit updates its buffer as data is received from the line. In this manner, a data stream of more than 1920 bytes may be accommodated, even though the buffer is only 1920 bytes. The System/34 must collect the entire line transmission before performing any of the embedded commands and orders. This implies:

- The line buffer may have to be larger than 1920 bytes (depending on the application).
- 3270 data streams in excess of 4096 bytes may be acceptable to a 3271 Model 2, but are not receivable by the System/34 (whose maximum line buffer size is 4096 bytes). These 4096 bytes include all the line control characters.

BSC 3270 device emulation translates received 3270 data streams into 5250 data streams. Therefore, a received 3270 data stream that is smaller than 4096 bytes (the maximum line buffer size) could cause BSC 3270 device emulation to terminate abnormally, since it may be translated into a 5250 data stream larger than 4096 bytes.

Status Data

Status text is sent by the System/34 in response to a host system poll and is always in the format returned by a 3271 cluster control unit (for example, SOH- %R-STX-??-ETX, where the ?? is the status data). Status sent by BSC 3270 device emulation is a subset of status sent by the 3271, but the same status text might not be sent under the same conditions.

The status sent by BSC 3270 device emulation should be interpreted as follows:

- Operation check (OC)
 - Escape (ESC) did not immediately follow the STX in an outbound message.
 - An invalid buffer address for a 3277 Model 2 was detected in an outbound message.
 - The BSC 3270 subsystem line buffer was too small for an outbound message. (Line buffer size is specified on display 14.0 of CNFIGICF.)
- Command reject (CR)
 - A copy command was received.
 - An invalid command was received.
- Intervention required (IR)
 - No work station is signed on the specified 3270 network (device) address.
- Device busy (DB)
 - A printer is executing a start print operation.
 - A display station is signed on but not currently available.
- Device end (DE)
 - A previously busy device is no longer busy.
 - A work station has signed on to device emulation.
- Control check (CC)
 - A work station error occurred during host communications.
 - The System/34 processing unit is heavily loaded. (The delay count can be changed on display 14.0 of CNFIGICF.)
- Unit specify (US)
 - A command was sent to a busy device.

Chapter 3. SNA 3270 Device Emulation

The SNA support of the 3270 Device Emulation Program Product, hereafter referred to as SNA 3270 device emulation, permits a System/34 to be attached to an SNA 3270 network and appear as a 3274 Model 1C control unit in that network. The host system can be using IMS/VS, CICS/VS, or TSO. Locally attached display stations and printers, when signed on to SNA 3270 device emulation, emulate display stations and printers locally attached to a 3274 control unit. Specifically, the System/34 devices emulate the 3270 devices as follows:

System/34 Device	3270 Device
5251 Model 11 Display Station	3277 Model 2 Display Station
5211 Printer (all models)	3284, 3286, 3287, or 3288 Model 2 Printer
5256 Printer (all models)	3284, 3286, 3287, or 3288 Model 2 Printer
3262 Printer (all models)	3284, 3286, 3287, or 3288 Model 2 Printer
5224 Printer (all models)	3284, 3286, 3287, or 3288 Model 2 Printer
5225 Printer (all models except 11 and 12)	3284, 3286, 3287, or 3288 Model 2 Printer
5219 Printer (all models)	3284, 3286, 3287, or 3288 Model 2 Printer

The remainder of this chapter describes the support provided by SNA 3270 device emulation. The chapter is divided into three parts. The first is for the display station operator, and describes how to operate SNA 3270 device emulation. The second is for the System/34 operator and System/34 programmer, and describes System/34 considerations for running SNA 3270 device emulation. The third is for the System/34 programmer and host system programmer, and describes considerations for configuring, installing, and using SNA 3270 device emulation.

Operating SNA 3270 Device Emulation

SNA 3270 device emulation can be run from any locally attached 1920-character display station (5251 Model 11). The operator must perform the following tasks when using SNA 3270 device emulation:

- Signing on to the 5251 display station
- Signing on to SNA 3270 device emulation
- Handling error messages
- Identifying operating differences from 3270 devices, including:
 - Differences in keyboard appearances and function
 - Differences in display screens
 - Differences in printer functions
- Signing off SNA 3270 device emulation
- Signing off the 5251 display station

Each of these tasks is described in the following sections.

SIGNING ON TO THE 5251 DISPLAY STATION

You must sign on to the 5251 display station before you can sign on to SNA 3270 device emulation. To sign on to the 5251 display station, do the following:

1. Press the shift key () and the Sys Req/Attn key simultaneously; then press the Enter/Rec Adv key. A sign-on display appears.
2. Key your user ID and password (if required) and any other appropriate information, and press the Enter/Rec Adv key.

If the user ID and password are valid, you will be signed on to the 5251 and ready to sign on to device emulation. If the user ID or password was invalid, you must enter a correct ID and password before you can proceed.

SIGNING ON TO SNA 3270 DEVICE EMULATION

Signing on to SNA 3270 device emulation requires that you enter the ES3270 procedure command. Before you can enter this command, the system operator must have enabled an SNA 3270 subsystem configuration. If the subsystem has not been enabled, you will receive an error message (ESU-3101) indicating that the support is not active.

Signing On a Display Station

The format of the ES3270 procedure command for signing on a display station is:

```
ES3270 [work station id] , [ON] , [location name] , [printer id]
```

work station id: Specifies the logical ID of the display station to be signed on. If the display station being signed on is the one from which the command was entered, this parameter is not required. If the ID is that of another display station, that display station must be a data display station that is not currently in use or a command display station in standby mode.

ON: Specifies that you want to sign on to SNA 3270 device emulation. This parameter is not required, because it defaults to ON.

location name: Specifies the location name associated with this session. The location name refers to the name of the remote location with which communication is to take place. If only one SNA 3270 device emulation remote location is active, this parameter can be omitted.

printer id: Specifies the ID of a printer that is to be used for a host-initiated copy function. This parameter corresponds to the print authorization matrix used by the 3274. The default is the ID of the printer used when the print key is pressed at this display station.

Signing on a display station to SNA 3270 device emulation is the same as powering on a 3277 display station. Once the display station is signed on to SNA 3270 device emulation, the display screen is cleared and the cursor positioned at row 1, column 2. The display station is in System Request mode, waiting for you to enter a LOGON command.

Signing On a Printer

You can also sign a printer on to SNA 3270 device emulation. The format of the ES3270 procedure command for signing on a printer is:

ES3270 work station id, [ON] , [location name] , $\left[\begin{array}{c} \text{YES} \\ \text{NO} \end{array} \right]$, $\left[\begin{array}{c} \text{YES} \\ \text{NO} \end{array} \right]$,
[priority] , [positions] , [lines]

work station id: Specifies the logical ID of the printer to be signed on. If the output for this printer is not being spooled, this printer must not currently be in use.

ON: Specifies that you want to sign on to SNA 3270 device emulation. This parameter is not required, because it defaults to ON.

location name: Specifies the location name associated with this session. The location name is defined during subsystem configuration and refers to the name of the location with which communication is to take place. If only one configuration of SNA 3270 device emulation is active, this parameter can be omitted.

YES/NO: Specifies whether output to the printer is to be spooled. YES specifies that output is to be spooled, and is the default. NO specifies that output is not to be spooled. If this printer is not using spooling, this parameter is ignored.

YES/NO: Specifies when spooled output should be printed. YES indicates that printing of spooled output is deferred until the printer is signed off SNA 3270 device emulation; YES is the default. NO indicates that printing of spooled output is not deferred until the printer is signed off. If this printer is not using spooling, this parameter is ignored.

priority: Specifies the priority for spooled output. The priority is a decimal integer from 0 through 5, with 5 being highest priority (printed first), 1 being lowest priority, and 0 indicating that the output should be held until a RELEASE control command is entered. If this parameter is not specified, 1 is assumed. If this printer is not using spooling, this parameter is ignored.

positions: Specifies the initial number of print positions in a line. Any decimal integer from 1 through 132 can be specified; 132 is the default. This parameter applies only when you are signing on a printer that will use SNA character strings (a feature of the 3287 printer).

lines: Specifies the initial number of lines per page. Any decimal integer from 1 through 255 can be specified. The default is the currently defined lines per page value. This parameter applies only when you are signing on a printer that will use SNA character strings (a feature of the 3287 printer).

Because signing on to device emulation is the equivalent of turning on the power at a 3284, 3286, 3287, or 3288 printer, you may have to enter a logon command or other host sign on information before you can begin other tasks.

HANDLING ERROR MESSAGES

While signing on and operating SNA 3270 device emulation, you can get three kinds of System/34 error messages. All of these messages are explained in the *Displayed Messages Guide*.

Error messages pertaining explicitly to SNA 3270 device emulation are identified by ESU- followed by a 4-digit number. These messages are described in the ESU section of the messages guide.

System errors are identified by SYS- followed by a 4-digit number. These messages are described in the SYS section of the messages guide.



Flashing 4-digit numbers in the lower left corner of the display screen are keyboard errors. If you press the Help key when the number is flashing, a message will appear at the bottom of the display. Keyboard errors are described in the KBD section of the messages guide.

OPERATING DIFFERENCES

The following sections describe the differences between System/34 devices and 3270 devices, specifically keyboard, display screen, and printer differences.

Keyboard Differences

The placement and function of keys differ between the 5251 keyboard and the 3277 keyboard. Figure 3-1 shows the comparative placement of the keys on the 3277 and the 5251 keyboards. The numbers show the corresponding key(s) on the other keyboard. The numbers also appear in Figure 3-2, which provides a summary of the functions of the 3277 keyboard and how they are performed on the 5251 keyboard. In the 5251 column of Figure 3-2, multiple keys are often shown. Where this occurs, the keys must be pressed in the order shown. When the shift key () is shown, hold down this key

while pressing the next key. For example, if the figure shows:   

press and release  ; then hold down the shift key ()

while pressing the  key.

3277 Keyboard

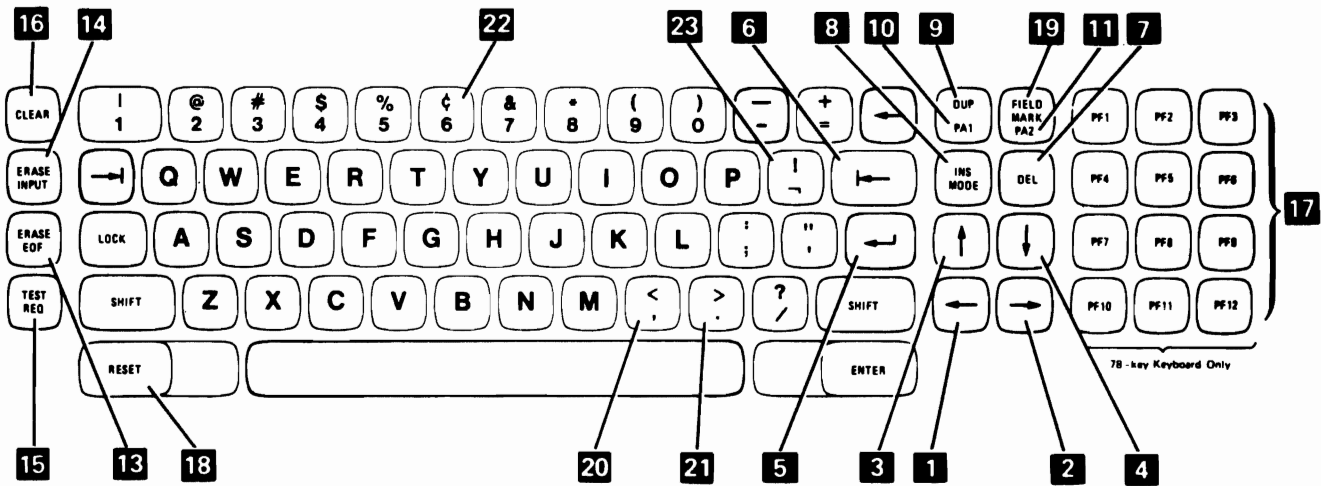

5251 Keyboard

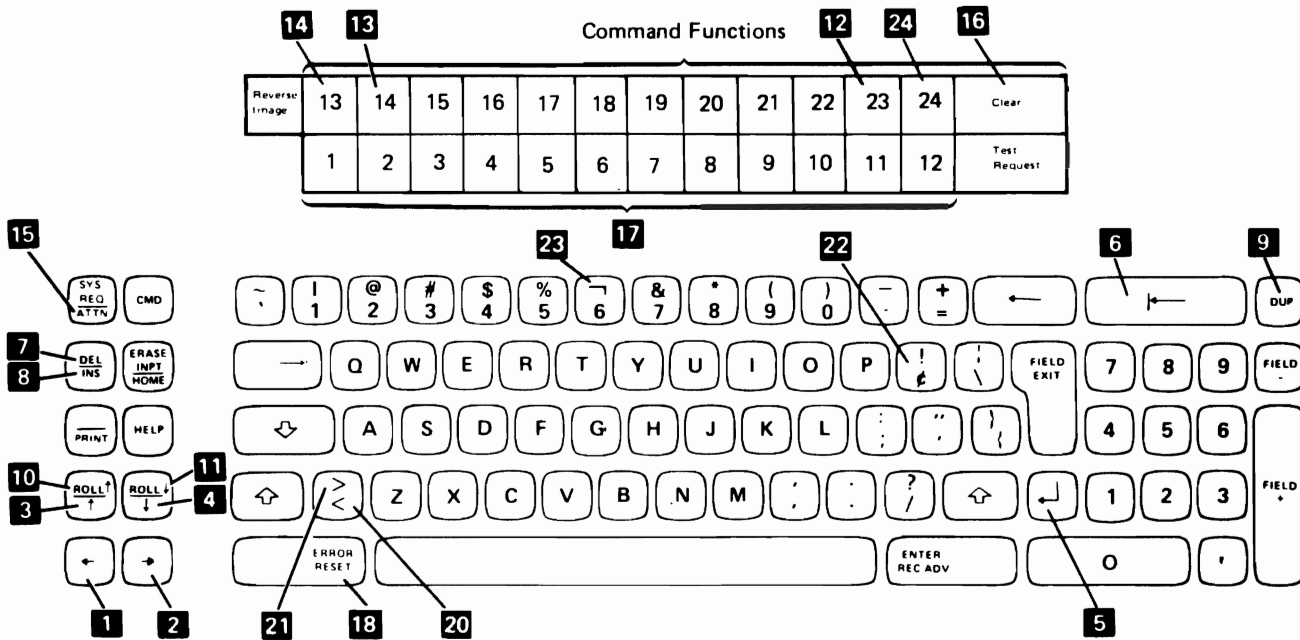

Note: The lower row of the template shown above the 5251 keyboard corresponds to the numeric keys on the top row of the 5251 keyboard after the Cmd key has been pressed. The upper row of the template corresponds to the numeric keys with the shift key held down after the Cmd key has been pressed.

Figure 3-1. 3277 Keyboard and 5251 Keyboard Placement

	3277 Key	Function	5251 Key
1		Cursor move left	
2		Cursor move right	
3		Cursor move up	
4		Cursor move down	
5		New line	
6		Back tab	
7	DEL	Delete	
8	INS MODE	Insert	
9	SHIFT DUP PA1	Duplicate	DUP
10	DUP PA1	Program attention 1	
11	FIELD MARK PA2	Program attention 2	
12	(See Note 1)	Program attention 3	CMD
13	ERASE EOP	Erase to end of field	CMD





	3277 Key	Function	5251 Key
14	ERASE INPUT	Erase input fields (See Note 2)	CMD
15	TEST REQ CLEAR OR TEST REQ DUP PA1	System request or Attention	(See Note 3)
16	CLEAR	Clear screen	CMD
17	PF1 through PF12	Program function 1 - 12	CMD through
18	RESET	Reset	 (See Note 4)
19	SHIFT FIELD MARK PA2	Field mark	Not Supported
20	SHIFT <	Less than	> <
21	SHIFT >	Greater than	> <
22	SHIFT ¢ 6	Cent	
23	! ~	Logical not	
24	Power off	Sign off	CMD (See Note 3)

Notes:

1. This key is not on the data entry keyboard.
2. Do not use the 5251 Erase Input key to perform the 3277 erase input function. The results will be unpredictable.
3. Refer also to *Attn Key Functions* following this figure.
4. The 3277 Reset key unlocks a locked keyboard and resets insert mode. The 5251 Error Reset key resets insert mode. The 5251 Attn key (followed by option 1) unlocks a locked keyboard while device emulation is being used. (See also *Attn Key Functions* following this figure.)

Figure 3-2. Keyboard Functions Chart

Attn Key Functions: For SNA 3270 device emulation, the Attn key provides several functions. If you press the Attn key while using SNA 3270 device emulation, a display appears indicating that you have the following options:

- | Option | 3277 Function |
|--------|--|
| 0 | Return to normal processing |
| 1 | Reset key () |
| 2 | Attention key ( ) |
| 3 | System request key ( ) |
| 4 | Terminate 3270 emulation (power off) |



Also, the System/34 inquiry function is available if you press the Attn key again.

Command Key Functions: The following chart summarizes the functions available after the Cmd key is pressed:

Display Mode	13 Erase Input	14 Erase EOF	15	16	17	18	19	20	21	22	23 PA3	24 	Clear
	1 PF1	2 PF2	3 PF3	4 PF4	5 PF5	6 PF6	7 PF7	8 PF8	9 PF9	10 PF10	11 PF11	12 PF12	Test Request

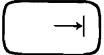
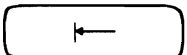

You can copy this information onto one of the blank templates on the *IBM 5251 Display Station Models 1 and 11/IBM 5252 Dual Display Station Keyboard Template, GX21-9266*.

Key Function: The functions performed by the following 5251 keys differ from the corresponding 3277 functions:

- The 5251 tab (), back tab (), and new line () keys position the cursor to the home address whenever no input fields exist. The home address is always row 1 column 1 on the 3277, but varies on the 5251 according to where the cursor was positioned when the keyboard was unlocked.
- The 5251 Insert/Delete key () works on the entire input field, regardless of whether the field continues onto the next line.
- The 5251 Dup key fills the remainder of an input field with a special asterisk-overscore character (*̄). Disregard the additional characters on the 5251 display screen; SNA 3270 device emulation recognizes that the Dup key was pressed, and performs the desired function.
- The 3277 field mark (hex 1E) is displayed on the 3277 as a semicolon (;) and is printed as an asterisk. On the 5251, it is displayed and printed as a solid box; the field mark key is not supported on the 5251.
- The 5251 command key 14 performs the same function as the Erase EOF key on the 3277.
- Insert mode on the 5251 must be reset before you exit from an input field. If you press a command key or roll key while in insert mode, an error message is issued. If you press the Enter/Rec Adv key while in insert mode, insert mode is reset and the enter function is performed.

CAUTION

Do not use the 5251 Field Exit key to perform the 3277 Erase EOF function; the results are unpredictable.

Do not use the 5251 Erase Input key to perform the 3277 erase input function. The display will indicate that the function was performed; however, the results will be unpredictable. If you accidentally press the 5251 Erase Input key, press command key 13 (  ), which performs the

device emulation erase input function. You can then continue with normal processing.

Display Screen Differences

When you are operating a 5251 using SNA 3270 device emulation, note the following differences between the 3277 and the 5251 display screens:

- You cannot key input into row 1 column 1 of the 5251.
- Filling in the last position of an input field does not always advance the cursor to the next input field. If the cursor does not automatically advance, it blinks in the last position of the input field. Press the Field Exit key to go to the next input field.

In addition to these operating differences, the host system programmer should know some additional differences between the 5251 and 3277 display screens. For a description of these differences, see *Host Programming Considerations* later in this chapter.

If you want a printed copy of the contents of a display, use the key sequence defined by the host (for example, PF 12 for IMS). The printer specified in parameter 4 of the ES3270 procedure command when the display station was signed on is used. You can also press the 5251 Print key. In either case, the printer for the copy request does not need to be signed on to SNA 3270 device emulation to perform this function.

Printer Considerations

Keep the following printer considerations in mind when using SNA 3270 device emulation to produce printed output:

- SNA 3270 device emulation output written to a spooled System/34 printer is not normally printed until the spool file is closed. If this is not satisfactory, you can specify NO for parameter 5 of the ES3270 procedure command when signing on the printer. The spool file is closed when the printer is signed off SNA 3270 device emulation, or when the SNA 3270 device emulation support is disabled.
- The 5256, 5211, 3262, and 5225 printers on the System/34 have a switch to set the number of printed lines per inch to 6 or 8. SNA 3270 Device Emulation supports only 6 lines per inch. To ensure that the printed output is formatted the same, set the System/34 printer switch to 6 lines per inch.
- The 5224 and 5225 printers allow a setting of 10 or 15 characters per inch in a printed line. The printers emulated print only 10 characters per inch. To ensure that the output is formatted the same, set the 5224 or 5225 printer to 10 characters per inch.
- If printer sharing is desired (for example, printer emulation and the host copy function using the same printer), print spooling must be used.
- SNA 3270 device emulation support of the SCS control codes is different than the support provided for the 3287 printer. The differences are:
 - Set Line Density (SLD). The 3287 printer support allows you to specify line density as either 6 or 8 lines per inch. SNA 3270 device emulation ignores this control code.
 - Vertical Channel Select (VCS). The 3287 printer does not allow skipping to a specified channel. The 3287 always does a line feed (LF) when the VCS code is received. SNA 3270 device emulation supports skipping to a specified channel.
- SNA 3270 device emulation supports two types of sessions for a printer:
 - Data stream is SCS mode format (logical unit type 1 - LU1)
 - Data stream is Data Stream Compatibility (DSC) mode format (logical unit type 3 - LU3)

The SNA Bind command specifies the session type.

SIGNING OFF SNA 3270 DEVICE EMULATION

Before signing any display station off device emulation, be sure to sign off the host system. You can sign off the host system by pressing the Attn key, selecting option 3, and entering a host logoff command. Signing off device emulation is the equivalent of turning off the power at a 3277 display station or a 3284, 3286, 3287, or 3288 Model 2 printer.

Signing off SNA 3270 device emulation is done differently depending on the device being signed off.

To sign your own display station off SNA 3270 device emulation, press command key 24 or press the Attn key and select option 4.

To sign off a printer or display station (except the one entering the ES3270 command), use the ES3270 procedure command. The format of the ES3270 procedure command for signing off SNA 3270 device emulation is:

ES3270 work station id,OFF

work station id: Specifies the logical ID of the display station or printer to be signed off. The display station entering the ES3270 command cannot be the one signed off. The display station being signed off will return to standby mode.

OFF: Specifies that the device is to be signed off SNA 3270 device emulation.

SIGNING OFF THE 5251 DISPLAY STATION

After you have signed off SNA 3270 device emulation, you can sign off the 5251 display station. To sign off the 5251, key in OFF and press the Enter/Rec Adv key. The sign-on display appears, and the display station is ready for its next user.

Running SNA 3270 Device Emulation

ALTERSDL AND SPECIFY PROCEDURES

When preparing to run SNA 3270 device emulation, you might want to change some of the items configured for the communications line. To change the items, run the ALTERSDL procedure or the SPECIFY procedure. Before running the procedure, you can check the configuration by using the STATUS COMM operator command. A separate configuration record exists for each command display station. SNA 3270 device emulation uses the system console configuration record, so be sure to enter the STATUS command and run the ALTERSDL and SPECIFY procedures from the system console.

The following items can be changed by the ALTERSDL procedure:

- Modem rate (full or half)
- World Trade answer tone
- Clocking
- Switched network backup
- IBM modem

The following items can be changed by the SPECIFY procedure:

- Secondary station address
- Line type (options P, nonswitched point-to-point, and S, switched point-to-point, are the only valid options. Option P must be used for a multipoint line.)
- Switch type
- Line ID

For additional information about the ALTERSDL and SPECIFY procedures, see the *SSP Reference Manual*.

ENABLE PROCEDURE

To start the SNA 3270 device emulation support, the ENABLE procedure must be run from the system console. The ENABLE procedure performs the following functions for SNA 3270 device emulation:

- Determines whether the line requested is available.
- Loads and attaches the SNA 3270 support if it is not already active.
- Loads and attaches the SNA and SDLC tasks if they are not already active.

The format of the ENABLE procedure command is:

ENABLE name, [#LIBRARY]
library name, line number, [SHOW]
NOSHOW [, remote location name]

name: Specifies the member name of the subsystem configuration to be enabled.

library name: Specifies the name of the library that contains the specified subsystem configuration. The default is #LIBRARY.

line number: Specifies the number of the communications line for which this subsystem is to be enabled.

SHOW/NOSHOW: Specifies whether subsystem configuration parameters are to be displayed before the subsystem is enabled. NOSHOW is the default. If SHOW is specified, the parameters are displayed, and some of them can be changed. You can use the SHOW parameter to change the following:

- SSP-ICF common queue space (if this is the first subsystem enabled)
- SSP-ICF subsystem queue space
- Swappability of the subsystem
- Switch type
- SDLC buffer pool size
- Number of transmit buffers
- Maximum receive pacing count
- Local ID
- Logical unit configuration table member name
- Logical unit configuration table library name
- Location activated status, on or off

remote location name: Specifies the name (as specified on display 9.1 during CNFIGICF) of the remote location with which communications is to occur.

After being enabled, SNA 3270 device emulation begins to monitor the communications line, responding to command sequences as a 3274 Model 1C control unit would respond if all its devices were powered off.

After the ENABLE procedure has been run, the ES3270 procedure command can be used to sign devices on to SNA 3270 device emulation. This is analogous to powering on a 3277 display station or printer.

DISABLE PROCEDURE

To de-activate SNA 3270 device emulation, the DISABLE procedure must be run from the system console. When a disable is performed, SNA 3270 device emulation waits for the host system to de-activate the logical units and send an SNA disconnect command. If something prevents the host from doing either (for example, a machine check at the host), the subsystem remains active until a link error occurs, an IPL is performed at the System/34, or a second disable is requested.

When the last configuration of SNA 3270 device emulation terminates, the host system sees the System/34 as a 3274 control unit that has been powered off. When a disable is requested, the following functions are performed:

- If no active devices are using SNA 3270 device emulation, the configuration is disabled, and the main storage being used is freed. If SNA 3270 device emulation is not active on another line, the support is terminated; SNA and SDLC are also terminated if they are not in use.
- If devices are signed on to SNA 3270 device emulation, a message is issued to the system operator with the following options:
 - Hold the disable. New sessions are prevented from being started and, when all sessions complete, a normal disable occurs.
 - Retry the disable. Check again for any active sessions.
 - Cancel active sessions and disable. Active sessions are immediately terminated, and the disable is performed.
 - Ignore the disable request. The DISABLE procedure is canceled, and must be run again when a disable is desired.
- If a disable is already being held, a message is issued to the system operator with the following options:
 - Force a disable of all subsystems using this line; do not wait for the host to terminate the line.
 - Ignore the disable request. The DISABLE procedure is canceled, and must be run again when a disable is desired.

The format of the DISABLE procedure command is:

DISABLE name, [remote location name]

name: Specifies the member name of the subsystem configuration to be disabled.

remote location name: Specifies the name of the remote location to be disabled.

SNA 3270 Device Emulation Considerations

SYSTEM/34 REQUIREMENTS

The System/34 requires a minimum of 64 K bytes of main storage to support SNA 3270 device emulation. A larger main storage is recommended, and is required if multiple devices are to be attached concurrently. SNA 3270 device emulation requires 18 K bytes of nonswappable storage plus 16 K bytes of storage that can be specified as swappable during subsystem configuration. In addition, each attached display station requires 16 K bytes of swappable main storage; each attached printer requires 8 K bytes of main storage.

Work station controller expansion feature A or B is required on the System/34. SNA 3270 device emulation requires that the SDLC microcode be configured for either a switched or nonswitched line.

The 3270 Device Emulation Program Product is designed to run under the control of the System/34 System Support Program Product. The Interactive Communications Feature (SSP-ICF), a separately priced feature, must also be installed and active on the system. Specifically, the SNA 3270 support subsystem must be configured and active to run SNA 3270 device emulation.

SETTING UP SNA 3270 DEVICE EMULATION

The SSP procedures CNFIGSSP and INSTALL are used to include the interactive communications and SNA 3270 device emulation support on the System/34. The general interactive communications support is included by requesting it on the appropriate CNFIGSSP prompt. The SNA 3270 device emulation support is then copied to the SNA 3270 device emulation library (#ES74LIB) by taking the appropriate responses to the INSTALL procedure prompts. The CNFIGSSP and INSTALL procedures, with their displays and related responses, are described in the *Installation/Modification Reference Manual*.

After SNA 3270 device emulation has been installed, the CNFIGICF procedure is used to tailor the support to an existing or proposed network. The operation of the CNFIGICF procedure is also explained in the *Installation/Modification Reference Manual*. Before running the CNFIGICF procedure, however, you should fill out a planning chart for each configuration that you want to define. Copies of the planning chart for SNA 3270 device emulation are available at the end of this manual and in the *Installation/Modification Reference Manual*. The following sections explain how to fill out the planning chart for SNA 3270 device emulation.

Display 1.0 Subsystem Member Configuration

1.0	Subsystem Member Configuration	
1.	Subsystem configuration member name (8 characters)	_____
2.	Subsystem library name (8 characters)	_____
	Select:	
	1. Create new member	4. Delete a member
	2. Edit existing member	5. Review a member
	3. Create new member from existing member	
3.	Enter selection: _____	
4.	Existing member name:	_____
5.	Existing member library name:	_____

Subsystem configuration member name: Specify a name for this configuration. The name is used to store the member in a library, and is referenced in the ENABLE and DISABLE procedures.

Subsystem library name: Specify the name of a library in which the configuration is stored or to be stored. Although the default is #LIBRARY, you should store the configuration in a user library.

Enter selection: Specify one of the five options: (1) create a new member, (2) edit an existing member, (3) create a new member from an existing member, (4) delete a member, or (5) review a member without changing it.

Existing member name: This prompt appears only if option 3 was selected. Specify the name of the existing subsystem configuration member that is to be used to create the new member. The existing member remains unchanged.

Existing member library name: This prompt appears only if option 3 was selected. Specify the library name where the existing member resides.

Display 2.0 Common SSP-ICF Parameters for Each Subsystem

2.0 Common SSP-ICF Parameters for Each Subsystem

1. SSP-ICF common queue space: (2 - 42 K) — —
2. Define the subsystem type: — 9
 - 1 Intra
 - 2 BSC IMS/IRSS
 - 3 BSCEL
 - 4 BSC CICS
 - 5 BSC CCP
 - 6 SNA Upline
 - 7 SNA Peer
 - 8 BSC 3270
 - 9 SNA 3270
 - 10 Finance

SSP-ICF common queue space: Specify the size, in multiples of 2 K bytes, of the common queue space. The requirements depend on the values specified for other CNFIGICF parameters. The common queue space requirements for each configuration of SNA 3270 device emulation enabled are:

$$C = 40M + 176A + 376 + (2X + 4)^* + (2L + 2)^*$$

where

C = number of bytes required for the common queue space

M = maximum number of devices concurrently attached to this configuration

X = number of transmit buffers

A = number of acquired sessions that will be active concurrently

L = number of logical units defined in the logical unit configuration table

*Rounded up to the next multiple of 8

The common queue space value specified for the first subsystem that is enabled becomes the size of the common queue space. Be sure that the value specified for common queue space size takes into account the requirements of any other subsystem that might be active concurrently.

The size of the common queue space plus the total subsystem queue space sizes of all enabled SNA 3270 configurations cannot exceed 42 K bytes.

The default common queue space size is 4 K bytes.

Define subsystem type: Specify a 9 for the SNA 3270 subsystem.

Display 3.0 General Subsystem Parameters

3.0	General Subsystem Parameters		
1.	Location name:	(8 characters)	-----
2.	Subsystem queue space:	(2-40 K)	--
3.	Subsystem support swappable:	(0-No 1-Yes)	--

Location name: Specify up to 8 characters for the name of the location associated with this configuration. The location name is used in some of the message texts, and can be specified in the ES3270 procedure. The default is the subsystem configuration name. The location name refers to the name of the location with which communication is to take place.

Subsystem queue space: Specify the size, in multiples of 2 K bytes, of the subsystem queue space. For each concurrently attached printer, 264 bytes are required. For each concurrently attached display station, 520 bytes are required. The default is 2 K bytes.

Subsystem support swappable: Specify whether you want the SNA support to be swappable. Consider the total system performance, the size of the subsystem, and the amount of user main storage when determining whether you want the SNA support swappable. The swappable portion of SNA requires 12 K bytes of main storage.

Note: The subsystem always requires 4 K bytes of nonswappable storage and 4 K bytes of swappable storage.

Display 4.0 Line Information for SSP-ICF Subsystem

4.0 Line Information for SSP-ICF Subsystem

- | | | | |
|----|------------------------|---------------------|----|
| 1. | Line type: | | — |
| | | 2-Nonswitched Pt-Pt | |
| | | 3-Switched Pt-Pt | |
| 2. | Local station address: | (2 hex) | -- |
| 3. | Switch type: | | — |
| | 1 Manual call | 2 Auto answer | |
| | 3 Manual answer | | |

Line type: Specify the line type that is suitable to your communications environment. The default is 2 (nonswitched point-to-point).

Local station address: Specify the System/34 station address identified for this configuration. This value must be specified as two hexadecimal digits in the range of 01 to FE.

Switch type: This prompt is displayed only if switched point-to-point line type was selected. Specify the switch type you want for the line. The default is 1 (manual call). If the switch type is defined as 2 (auto answer), the communications adapter is initially enabled as automatic answer. If a device attempts to sign on to SNA 3270 device emulation before the line has been connected, the switch type is temporarily changed to allow the System/34 operator to make the call.

Note: If SNA 3270 device emulation is to be run on a line with the SNUF subsystem, the values from this display specified in the two configurations must agree. If the values are not the same, an error occurs when the second subsystem is enabled.

Display 8.0 SNA General Subsystem Parameters

8.0 SNA General Subsystem Parameters	
1.	SDLC buffer pool size: (2-8 K) —
2.	Number of transmit buffers: (1-15) — —
4.	Maximum receive pacing count: (1-63) — —
5.	Local ID: (Hexadecimal) — — — — —
6.	LU configuration library name — — — — —
7.	LU configuration member name — — — — —

SDLC buffer pool size: Specify the amount of main storage, in multiples of 2 K bytes, to be used for SDLC buffers. The following table shows the number of buffers available for each possible value specified:

Pool Size	Buffers
2 K	7
4 K	15
6 K	22
8 K	30

The default is 4 K. The total active secondary SDLC buffer pool size (including all users of secondary SDLC) cannot exceed 48 K bytes.

Number of transmit buffers: Specify the number of transmit buffers you require. Specify a number from 1 to 15. All transmit buffers will be in main storage. If the SDLC buffer pool size is not sufficient for the number of transmit buffers and receive buffers, an error message is displayed. For example, if you have specified 2 K of main storage for the SDLC buffer pool, you would have seven buffers available. Three buffers are required to be receive buffers; therefore, you would be able to specify up to four transmit buffers. The number of receive buffers in main storage is equal to the total number of buffers available minus the number of transmit buffers. The default number of transmit buffers is 7.

Maximum receive pacing count: Each logical unit of the host system contains a receive pacing count. This count directly affects the amount of application data that can be queued by System/34 SNA. Specify the maximum receive pacing count that was determined by the host system. You can specify a value from 1 to 63. If large quantities of data records are to be sent, a larger receive pacing count could allow them to be sent more efficiently. If only one or a few records will be sent at a time, a smaller receive pacing count will be sufficient and will require less storage for receive buffers. The default is 3.

Note: This pacing count should agree with the host-specified pacing count.

Local ID: Specify five hexadecimal digits to be used as the SDLC exchange of identification for the System/34. The default is 00000. This ID must be the same as the host-specified remote ID. The host specifies the remote ID in the IDNUM parameter of the PU macro for the VTAM switched line definition. This prompt is checked only if a switched point-to-point line type is selected.

Note: If SNA 3270 device emulation is to be run concurrently on a line with the SNUF subsystem, the values for parameters 1, 2, 5, 6, and 7 on this display in the two configurations must agree. If the values are not the same, an error occurs when the second subsystem is enabled.

LU configuration table library name: Specify the name of the library containing the logical unit configuration table. This name must be the name specified when the table was built by the DEFINELU procedure. The DEFINELU procedure is described in the *Interactive Communications Feature Reference Manual*.

LU configuration table member name: Specify the name of the member containing the logical unit configuration table. This name corresponds to the name assigned to the table when it was built by the DEFINELU procedure. The DEFINELU procedure is described in the *Interactive Communications Feature Reference Manual*.

Display 9.1 SNA Upline/3270 Station Parameters

The following display, 9.1, is presented only if the line type specified on display 4.0 was switched point-to-point (option 3).

Up to 32 remote locations can be configured. Each iteration of display 9.1 defines a single remote location. If no remote location is defined using display 9.1 and the line type selected is switched point-to-point, the location name used is that specified on display 3.0. In addition, the system services control point identifier (SSCPID) of the remote location is not checked.

9.1	SNA Upline/3270 Station Parameters	
1.	Remote location name:	-----
2.	SSCPID:	(1-65535) -----
3.	Phone list name:	-----
4.	Location activated:	(0-No 1-Yes) -----

Remote location name: Specify up to eight characters for the name of the remote location associated with the parameters being defined. The location name refers to the name of the location with which communications is to take place. This is the value used as the *remote location name* on the ENABLE statement when communications with the specified remote location is enabled.

SSCPID: Specify the five character numeric identifier of the system services control point for this location. The value specified must match the SSCPID parameter value in the ACF/VTAM start procedure. If the System/34 initiates communications with the remote location, the SSCPID is used to verify that the correct location has been reached. If the remote location initiates communications with the System/34, the SSCPID is used to verify that the location is valid and to determine which location has called.

Note: It is assumed that each remote location has a unique SSCPID. If not, the System/34 cannot correctly determine to which remote location it is connected.

Phone list name: If the remote location is to be called automatically by the System/34, specify the library member name of the phone list created by the DEFINEPN procedure or the call list created by the DEFINX21 procedure, which are described in the *System Support Reference Manual*. The member must be in the same library as the configuration member or in the system library.

Note: Use of this parameter requires that the System/34 be configured with the multiline communications adapter and the autocall feature.

Location activated: Specify whether you want this location automatically activated when the subsystem is enabled. Specify 0 if not; or 1 if you want the location automatically activated. If 0 is selected, the location must be activated by a separate ENABLE command before it can be communicated with using device emulation.

Display 16.0 3270 Subsystem Device Parameters

16.0 SNA 3270 Subsystem Device Parameters

1.	Logical unit address	---	---	---	---	---	---	---	---	---	---	---	---	---	---	---	---	---	---	---
2.	Device type* (2, 3, or 5)	-	-	-	-	-	-	-	-	-	-	-	-	-	-	-	-	-	-	
3.	S/34 logical ID	---	---	---	---	---	---	---	---	---	---	---	---	---	---	---	---	---	---	
4.	Lowercase (0-No 1-Yes)	-	-	-	-	-	-	-	-	-	-	-	-	-	-	-	-	-	-	
5.	Logical unit address	---	---	---	---	---	---	---	---	---	---	---	---	---	---	---	---	---	---	
6.	Device type* (2, 3, or 5)	-	-	-	-	-	-	-	-	-	-	-	-	-	-	-	-	-	-	
7.	S/34 logical ID	---	---	---	---	---	---	---	---	---	---	---	---	---	---	---	---	---	---	
8.	Lowercase (0-No 1-Yes)	-	-	-	-	-	-	-	-	-	-	-	-	-	-	-	-	-	-	

* 2-3277 Display 2-3277 Display 3-3277 with Numeric Lock 5-3288 Printer

Logical unit address: Specify a logical unit address for each device to be attached to this configuration of SNA 3270 device emulation. The logical unit addresses correspond to values specified during host system generation. (See the chart later in this chapter for the relationship of the logical unit addresses to the host system configuration.) Up to 16 logical unit addresses may be specified for each configuration.

Device type: Specify the type of device that will be attached to the logical unit address. The device type is required if the logical unit address is specified, and is ignored otherwise. Possible values and their meanings are:

- 2 3277 Display. The logical unit address will be used to address a display station. The 5251 display station will emulate a 3277 display station using SNA 3270 device emulation.
- 3 3277 with Numeric Lock. The device address will be used to address a display station. The 5251 display station will emulate a 3277 display station with the Numeric Lock feature using the 3270 Device Emulation Program Product.
- 5 3288 Printer. The logical unit address will be used to address a printer. The printer on the System/34 will emulate a 3288 or 3287 line printer using SNA 3270 device emulation.

S/34 logical ID: Specify the logical ID of the work station to be used for the logical unit address. If the logical ID is specified, it must match the logical ID of a local display station or a local printer. The logical unit address is then reserved for use exclusively by that System/34 work station. A System/34 logical ID can appear only once in a configuration. If no logical ID is specified with a device address, any appropriate device type can use the device address on a first-come, first-served basis.

Lowercase: Do not specify this parameter for device type 5 (printer). Specify whether lowercase is allowed on the display station. Specify 0 (no) or 1 (yes). If lowercase is not specified, all lowercase characters are displayed and sent to the host system as uppercase characters.

This page is intentionally left blank.

VTAM/NCP GENERATION CONSIDERATIONS

The System/34 must be defined during VTAM/NCP generation. Each System/34 line is represented as a physical unit in the VTAM generation; therefore, each System/34 line that SNA 3270 device emulation uses requires a physical unit (PU) definition in the generation. The following parameters on the physical unit definition apply to SNA 3270 device emulation:

PUTYPE = 2

The physical unit type must be 2.

ADDR = xx

The ADDR parameter specifies the SDLC station address. This parameter must be the same as the local station address specified during subsystem configuration (display 4.0).

ISTATUS = ACTIVE/INACTIVE

The ISTATUS parameter specifies whether the physical unit should be activated when its major node is activated.

MAXDATA = 265

The MAXDATA parameter specifies the maximum amount of data, including the transmission header and request/response header, that the physical unit can receive. System/34 accepts a maximum of 265 bytes. System/34 does not support segmenting. To ensure that segmenting does not occur, the VTAM application output buffer size (OUTBUF for IMS or BUFFER for CICS) must not exceed MAXDATA minus 9.

MAXOUT = 7

The MAXOUT parameter specifies the number of records that NCP will send to the System/34 before requesting a response. For best performance, 7 should be specified.

DISCNT = YES/NO

The DISCNT parameter specifies whether VTAM is to disconnect the physical unit when the last logical unit session is ended. DISCNT=NO allows the System/34 to remain active when no sessions are active; the physical unit is de-activated when the last subsystem on the line is disabled. DISCNT=YES disconnects the System/34 when the last session terminates; SNA 3270 device emulation remains active until a disable is performed. DISCNT=YES also causes VTAM to ignore the System/34 disable request.

IDBLK = 00E

IDNUM = number

The *IDBLK* and *IDNUM* parameters make up the SDLC exchange ID. These parameters are specified only for a switched line. The *IDBLK* must be specified as 00E for a System/34. The *IDNUM* must be the same as the local ID parameter specified during subsystem configuration (display 8.0).

SSCPFM = USSSCS

Specifying *SSCPFM*=USSSCS indicates that the System/34 logical units associated with this physical unit use character-coded messages for communication with VTAM. The System/34 requires character-coded messages.

Each device attached to SNA 3270 device emulation corresponds to an SNA logical unit. A logical unit (LU) definition in the VTAM generation is required for each device.

LOCADDR = address

The *LOCADDR* parameter specifies the local address of the device. The local address is equivalent to a logical unit number. (The SNUF subsystem uses logical units 1 and 2 for incoming procedure start requests.) Any number of logical units can be defined; however, the number that can be active concurrently is limited to 16 per line.

ENCR = NONE

The *ENCR* parameter specifies the type of encryption to be used. Encryption is not supported by the System/34, so NONE must be specified.

ISTATUS = ACTIVE/INACTIVE

The *ISTATUS* parameter specifies whether the logical unit is to be activated when the physical unit is activated. You should not specify ACTIVE unless the logical unit address is specified in the System/34 SNA 3270 configuration and in the System/34 logical unit configuration table.

PACING = count

The *PACING* parameter specifies the way pacing is to be handled between NCP and the logical unit. This value should agree with the maximum receive pacing count value specified during subsystem configuration (display 8.0).

VTAM is also responsible for sending the bind command to SNA 3270 device emulation. Receipt of a correctly formatted bind command is required before device emulation can be started successfully. The bind command received from the host system must contain the following entries:

MODETAB			
Byte (Decimal)	Hex Value	Operand Name	Meaning
2	03	FMPROF	Function management (FM) profile
3	03	TSPROF	Transmission services (TS) profile
4	91 or A1 or B1	PRIPROT	Primary LU protocols
5	90 or A0 or B0	SECPROT	Secondary LU protocols
6, 7	3080	COMPROT	Common protocol
10, 11	8585	RUSIZES	Request/response unit size
14		PSERVIC	Second byte of the presentation services (PS) profile, SLU type 1(LU1) printer or SLU type 2(LU2) display station or SLU type 3(LU3) printer
20	1850	PSERVIC	Extended screen size (24 x 80)
24		PSERVIC	Byte 12 of the presentation services (PS) profile, Base default (12 x 40 or 24 x 80) or Base model 2 default (24 x 80) or Extended screen default (24 x 80)

For a complete description of the Bind parameters, see the *IBM 3270 Information Display System Components Description* and the *VTAM System Programmer's Guide*.

This page is intentionally left blank.

The following is a sample VTAM/NCP definition with the parameters that correspond to SNA 3270 device emulation configuration highlighted.

```
G1          GROUP  LNCTL=SDLC,TYPE=NCP,
                PACING=(3,1),ISTATUS=ACTIVE,
                DISCNT=NO,PASSLIM=7,
                MAXOUT=7,VPACING=(7,1),
                CUTYPE=SDLC1,DUPLEX=HALF,
                SPEED=9600,PAUSE=0.1,
                CLOCKING=EXT,
                RETRIES=(5,1,2),
                POLLED=YES,
                MAXDATA=265,
                SSCPFM=USSSCS
```

```
L023       LINE   ADDRESS=028,
                NRZI=YES,
                SPEED=7200,
                PACING=(7,1),
                ISTATUS=ACTIVE
```

```
1-----SERVICE ORDER=(PU023A,PU023B,PU023C)-----2
```

	PU023A	PU	ADDR= C1	,PACING=(7	,1),DISCNT=NO	
4 {	LU023A1	LU	LOCADDR= 01	,ISTATUS=ACTIVE		
	LU023A2	LU	LOCADDR= 02	,ISTATUS=ACTIVE		3
	LU023A3	LU	LOCADDR= 03	,ISTATUS=ACTIVE		
	LU023A4	LU	LOCADDR= 04	,ISTATUS=ACTIVE		
	LU023A5	LU	LOCADDR= 05	,ISTATUS=ACTIVE		
	LU023A6	LU	LOCADDR= 06	,ISTATUS=ACTIVE		
	LU023A7	LU	LOCADDR= 07	,ISTATUS=ACTIVE		
	LU023A8	LU	LOCADDR= 08	,ISTATUS=ACTIVE		
	LU023A9	LU	LOCADDR= 09	,ISTATUS=INACTIVE		
	LU023A10	LU	LOCADDR= 10	,ISTATUS=INACTIVE		

VTAM switched line definition:

SWS34A	VBUILD	TYPE=SWNET,SUBAREA=3,MAXNO=5, MAXGRP=5
PU024A	PU	ADDR=C1,PUTYPE=2,IDBLK=00E,IDNUM=00EC1, MAXPATH=2,MAXDATA=265,PACING=(3,1), BATCH=YES,VPACING=0,DISCNT=YES, ISTATUS=ACTIVE,PASSLIM=7,MAXOUT=7, SSCPFM=USSSCS
PATH1	PATH	DIALNO=3306,PID=1,GID=1,GRPNM=G2
LU024A1	LU	LOCADDR= 1
LU024A2	LU	LOCADDR= 2 ,ISTATUS=INACTIVE
LU024A3	LU	LOCADDR= 3 ,ISTATUS=INACTIVE
LU024A4	LU	LOCADDR= 4 ,ISTATUS=INACTIVE

- 1 This value corresponds to the local station address specified on display 4.0 of CNFIGICF.
- 2 This value corresponds to the maximum receive pacing count specified on display 8.0 of CNFIGICF.
- 3 For every logical unit address defined on display 16.0 of CNFIGICF, a corresponding VTAM/NCP logical unit definition must exist with the same value specified for LOCADDR.
- 4 The logical units defined as initially active should correspond to the logical units defined on display 16.0 of CNFIGICF and to those defined by the DEFINELU procedure.
- 5 This parameter is the same as that specified for local ID on display 8.0 of CNFIGICF.

HOST PROGRAMMING CONSIDERATIONS

The implementation of several functions on the System/34 is different from that on the host system. The following paragraphs describe those differences. Some changes to host system programming may be required before SNA 3270 device emulation is run, if any of these functions are currently used.

No 5251 display format can contain more than 127 input fields.

No field on the 5251 can wrap the screen (continue from row 24 column 80 to row 1 column 1). If the 5251 displays a 3277 screen format that wraps the screen, the character at row 1 column 1 is replaced with an input field attribute. If the starting cursor position is row 1 column 1, it is moved to row 1 column 2. Data is returned to the host as if row 1 column 1 contained a null character.

An unformatted 3277 display (one without attributes) is emulated on the 5251 by replacing the character at row 1 column 1 with an input field attribute. This allows the operator to key data into the remainder of the display. If the starting cursor position is row 1 column 1, it is moved to row 1 column 2. Data is returned to the host as if row 1 column 1 contained a null character.

If the 5251 Display Station is emulating a 3277 Display Station with the Numeric Lock feature, a comma, space, and plus sign can also be entered into a numeric field.

A 3277 modified field of length 0 (that is, an attribute with the modified data tag followed immediately by another attribute) is not supported by the 5251.

The maximum screen update (chain length) allowed by SNA 3270 device emulation is 3.5 K (3582) bytes. A screen update longer than this causes SNA 3270 device emulation to terminate. Also, a screen update smaller than 3582 bytes could cause SNA 3270 device emulation to terminate since it might be translated into a 5250 data stream that is larger than 3582 bytes.

SNA 3270 device emulation support of the 3274 print authorization matrix allows only one printer for each display station signed on to SNA 3270 device emulation to be specified as the destination for the host-initiated copy requests. That printer is specified in the fourth parameter of the ES3270 procedure command when a display station is signed on to SNA 3270 device emulation.

SNA 3270 device emulation does not support segmenting. See the *VTAM/NCP Generation Considerations* earlier in this chapter for information on how segmenting can be avoided.

SENSE DATA

If an error is detected while data is being processed, SNA 3270 device emulation responds with sense data as follows:

- **08010000**
 - (display emulation only) A host-initiated copy function cannot be performed because the associated printer is currently unavailable.
- **08020000**
 - (printer emulation only) An error has occurred on a printer, and operator intervention is required. When the condition is cleared, logical unit status is sent.
- **080A0000**
 - A bind command has been received for a device not currently signed on to SNA 3270 device emulation.
- **08130000**
 - (display emulation only) A bid command or a begin bracket has been received, and SNA 3270 device emulation is in the send state.
- **08210000**
 - A bind command contained unacceptable session parameters.
- **08290000**
 - A read type command was received, but the request header did not specify change direction.
- **082B0000**
 - An error has occurred at a display station, and the screen has been cleared.

- 082D0000
 - A message received on the logical unit address cannot be processed because SNA 3270 device emulation is in LU-SSCP session mode.
- 082F0000
 - A host-initiated copy cannot be performed because of an unrecoverable error at the associated printer.
- 08310000
 - The device associated with this session has been signed off SNA 3270 device emulation.
- 08430000
 - A write-type command with start print has been received in an exception response chain without change direction.
- 10030000
 - An unsupported data flow control command has been received.
 - An invalid 3270 command code has been received.
 - A data following read, read modified, read modified all, or erase all unprotected command has been received.
- 10050000
 - An invalid screen buffer address following a 3270 order has been received.
 - A set buffer address, repeat to address, or erase all unprotected to address command has been received without complete parameters.
 - An SNA character string parameter error was received.
- 10070000
 - Category is not supported.
 - An LU-SSCP MSG was directed to a printer.



BSC 3270 Subsystem Planning Chart

1.0 Subsystem Member Configuration

- 1. Subsystem configuration member name (8 characters) — — — — — — — —
- 2. Subsystem library name (8 characters) — — — — — — — —
- Select:
- 1. Create new member 4. Delete a member
- 2. Edit existing member 5. Review a member
- 3. Create new member from existing member
- 3. Enter selection: _____
- 4. Existing member name: — — — — — — — —
- 5. Existing member library name: — — — — — — — —

2.0 Common SSP-ICF Parameters for Each Subsystem

- 1. SSP-ICF common queue space: (2 - 42 K) — — 8
- 2. Define the subsystem type: — — 8
- 1 Intra 2 BSC IMS/IRSS
- 3 BSCEL 4 BSC CICS
- 5 BSC CCP 6 SNA Upline
- 7 SNA Peer 8 BSC 3270
- 9 SNA 3270 10 Finance

3.0 General Subsystem Parameters

- 1. Location name: (8 characters) — — — — — — — —
- 2. Subsystem queue space: (0-40 K) — —
- 3. Subsystem support swappable: (0-No 1-Yes) —
- 4. Maximum user record length: (0-4075) — — — —

4.0 Line Information for SSP-ICF Subsystem

- 2. Local station address: (2 hex) — —

14.0 3270 Subsystem General Parameters

- 1. Line buffer size: (256-4096) — — — —
- 2. Delay count: (0-255) — — — —

15.0 BSC 3270 Subsystem Device Parameters

- 1. Device address 40 C1 C2 C3 C4 C5 C6 C7 C8 C9 4A 4B 4C 4D 4E 4F
- 2. Device type* (1, 2, 3, or 5) — — — — — — — —
- 3. S/34 logical ID — — — — — — — —
- 4. Lower case (0-No 1-Yes) — — — — — — — —

- 5. Device address 50 D1 D2 D3 D4 D5 D6 D7 D8 D9 5A 5B 5C 5D 5E 5F
- 6. Device type* (1, 2, 3, or 5) — — — — — — — —
- 7. S/34 logical ID — — — — — — — —
- 8. Lower case (0-No 1-Yes) — — — — — — — —

* 1-Program 2-3277 Display 3-3277 with Numeric Lock 5-3288 Printer

Figure A-1. BSC 3270 Subsystem Planning Chart

SNA 3270 Device Emulation Planning Chart

8.0 SNA General Subsystem Parameters

- | | | | |
|----|-------------------------------|---------------|-----------|
| 1. | SDLC Buffer pool size: | (2-8 K) | _ _ |
| 2. | Number of transmit buffers: | (1-15) | _ _ _ |
| 4. | Maximum receive pacing count: | (1-63) | _ _ _ |
| 5. | Local ID: | (Hexadecimal) | _ _ _ _ _ |
| 6. | LU configuration library name | | _ _ _ _ _ |
| 7. | LU configuration member name | | _ _ _ _ _ |

9.1 SNA Upline/3270 Station Parameters

- | | | | |
|----|-----------------------|--------------|-----------|
| 1. | Remote location name: | | _ _ _ _ _ |
| 2. | SSCPID: | (1-65535) | _ _ _ _ _ |
| 3. | Phone list name: | | _ _ _ _ _ |
| 4. | Location activated: | (0-No 1-Yes) | _ |

16.0 SNA 3270 Subsystem Device Parameters

- | | | |
|----|---------------------------|-----------|
| 1. | Logical unit address | _ _ _ _ _ |
| 2. | Device type* (2, 3, or 5) | _ _ _ _ _ |
| 3. | S/34 logical ID | _ _ _ _ _ |
| 4. | Lowercase (0-No 1-Yes) | _ _ _ _ _ |
| 5. | Logical unit address | _ _ _ _ _ |
| 6. | Device type* (2, 3, or 5) | _ _ _ _ _ |
| 7. | S/34 logical ID | _ _ _ _ _ |
| 8. | Lowercase (0-No 1-Yes) | _ _ _ _ _ |

* 2-3277 Display 3-3277 with Numeric Lock 5-3288 Printer

Figure A-2 (Part 2 of 2). SNA 3270 Device Emulation Planning Chart



- activating BSC emulation 2-11
 - activating SNA emulation 3-12
 - address, local station, BSC 2-18
 - address, logical unit, SNA 3-22
 - addresses, device, BSC 2-20
 - ALTERBSC procedure 2-11
 - ALTERSDL procedure 3-12
 - Attn key functions, SNA 3-8
-
- bind parameters 3-24.1
 - BSC support 2-1
 - buffer pool size, SDLC 3-20
 - buffer size, BSC 2-19
 - buffers, transmit, SNA 3-20
-
- changing BSC environment 2-11
 - changing SNA environment 3-12
 - CNFIGICF, BSC 2-14
 - CNFIGICF, SNA 3-15
 - command key functions, BSC 2-8
 - command key functions, SNA 3-8
 - common queue space, BSC 2-16
 - common queue space, SNA 3-17
 - concurrent execution 1-2
 - configuration table, LU 3-21
 - configuring BSC emulation 2-14
 - configuring SNA emulation 3-15
-
- data transmission, BSC 2-23
 - de-activating BSC emulation 2-13
 - de-activating SNA emulation 3-14
 - DEFINEPN procedure 3-22
 - DEFINX21 procedure 3-22
 - delay count, BSC 2-19
 - device addresses, BSC 2-20
 - devices emulated, BSC 2-1
 - devices emulated, SNA 3-1
 - differences, BSC 2-5
 - differences, SNA 3-5
 - DISABLE procedure, BSC 2-13
 - DISABLE procedure, SNA 3-14
-
- display screen differences, BSC 2-9
 - display screen differences, SNA 3-10
 - display station sign off, BSC 2-10
 - display station sign off, SNA 3-11
 - display station sign on, BSC 2-3
 - display station sign on, SNA 3-3
-
- EM3270 procedure 2-3
 - ENABLE procedure, BSC 2-11
 - ENABLE procedure, SNA 3-12
 - error handling, BSC 2-23
 - error messages, BSC 2-5
 - error messages, SNA 3-5
 - ES3270 procedure 3-3
-
- generation considerations, VTAM/NCP 3-23
-
- host programming considerations, BSC 2-22
 - host programming considerations, SNA 3-27
 - host systems supported 1-1
-
- ID, local, SNA 3-21
 - ID, logical, BSC 2-20
 - ID, logical, SNA 3-22
 - installing BSC emulation 2-14
 - installing SNA emulation 3-15
-
- key functions, BSC 2-8
 - key functions, SNA 3-9
 - keyboard differences, BSC 2-5
 - keyboard differences, SNA 3-5

line buffer size, BSC 2-19
line sharing 1-3
local ID, SNA 3-21
local station address, BSC 2-18
logical ID, BSC 2-20
logical ID, SNA 3-22
logical unit address, SNA 3-22
LU configuration table 3-21

maximum record length, BSC 2-18
messages, BSC 2-5
messages, SNA 3-5

NCP generation considerations 3-23

operating BSC emulation 2-2
operating differences, BSC 2-5
operating differences, SNA 3-5
operating SNA emulation 3-2

pacing count, SNA 3-21
prerequisite publications iii
printer considerations, BSC 2-9
printer considerations, SNA 3-10
printer sign on, BSC 2-4
printer sign on, SNA 3-4
programming considerations, BSC 2-22
programming considerations, SNA 3-27

queue space, common, BSC 2-16
queue space, common, SNA 3-17
queue space, subsystem, BSC 2-17
queue space, subsystem, SNA 3-18

receive pacing count, SNA 3-21
record length, maximum, BSC 2-18
related publications iii
requirements 1-4
requirements, BSC 2-14
requirements, SNA 3-15
restrictions 1-4
running device emulation, BSC 2-11
running device emulation, SNA 3-12

SDLC buffer pool size 3-20
sense data, SNA 3-28
setting up BSC emulation 2-14
setting up SNA emulation 3-15
sharing communications lines 1-3
signing off, BSC 2-10
signing off, SNA 3-11
signing on a display station, SNA 3-2
signing on display station, BSC 2-2
signing on emulation, BSC 2-3
signing on SNA emulation 3-3
SNA support 3-1
SPECIFY procedure 3-12
spooling considerations, BSC 2-9
spooling considerations, SNA 3-10
SSP-ICF common queue space, BSC 2-16
SSP-ICF common queue space, SNA 3-17
starting BSC emulation 2-11
starting SNA emulation 3-12
station address, BSC 2-18
status data, BSC 2-23
stopping BSC emulation 2-13
stopping SNA emulation 3-14
storage requirements 1-4
storage requirements, BSC 2-14
storage requirements, SNA 3-15
subsystem queue space, BSC 2-17
subsystem queue space, SNA 3-18
system requirements, BSC 2-14
system requirements, SNA 3-15
system supported 1-1

transmission, BSC 2-23
transmit buffers, SNA 3-20

READER'S COMMENT FORM

IBM System/34
3270 Device Emulation Program Product
User's Guide

SC21-7868-1

You may use this form to communicate your comments about this publication, its organization, or subject matter, with the understanding that IBM may use or distribute whatever information you supply in any way it believes appropriate without incurring any obligation to you. Your comments will be sent to the author's department for whatever review and action, if any, are deemed appropriate.

Note: Copies of IBM publications are not stocked at the location to which this form is addressed. Please direct any requests for copies of publications, or for assistance in using your IBM system, to your IBM representative or to the IBM branch office serving your locality.

Please use this form only to identify publication errors or to request changes in publications.

Possible topics for comment are:

Clarity Accuracy Completeness Organization Retrieval Legibility

If your comment does not need a reply (for example, pointing out a typing error) check this box and do not include your name and address below. If your comment is applicable, we will include it in the next revision of the manual.

If you would like a reply, check this box. Be sure to print your name and address below.

Page number (s): Comment(s):

Please print

Name _____

Company or
Organization _____

Address _____

No postage necessary if mailed in the U.S.A.

_____ City State Zip Code

Cut Along Line

IBM System/34 3270 Device Emulation Program Product User's Guide (File No. S34-36) Printed in U.S.A. SC21-7868-1

Fold and tape

Please do not staple

Fold and tape



NO POSTAGE
NECESSARY IF
MAILED IN THE
UNITED STATES

BUSINESS REPLY MAIL
FIRST CLASS PERMIT NO. 40 ARMONK, N. Y.

POSTAGE WILL BE PAID BY . . .

International Business Machines Corporation
Development Laboratory
Information Development, Department 532
Rochester, Minnesota 55901

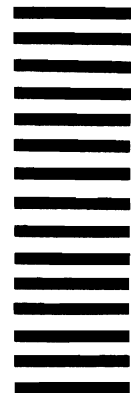

Fold and tape

Please do not staple

Fold and tape



International Business Machines Corporation

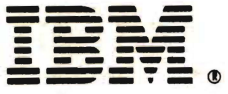

International Business Machines Corporation

IBM System/34 3270 Device Emulation Program Product User's Guide (File No. S34-36) Printed in U.S.A. SC21-7868-1