

# EXB-8205 & EXB-8505 8mm Tape Drives

---

standard and eXtended-Length configurations

## Integration and Optimization

## Copyright

Copyright 1994 by Exabyte Corporation. All rights reserved. This item and the information contained herein are the property of Exabyte Corporation. No part of this document may be reproduced, transmitted, transcribed, stored in a retrieval system, or translated into any language or computer language in any form or by any means, electronic, mechanical, magnetic, optical, chemical, manual, or otherwise, without the express written permission of Exabyte Corporation, 1685 38th Street, Boulder, Colorado 80301.

## Disclaimer

Exabyte Corporation makes no representation or warranties with respect to the content of this document and specifically disclaims any implied warranties of merchantability or fitness for any particular purpose. Further, Exabyte Corporation reserves the right to revise this publication without obligation to notify any person or organization of such revision or changes.

## Trademark Notices

EXABYTE and EXAPAK are registered trademarks, and EXATAPE and Compression Integrity Check are trademarks of Exabyte Corporation. All other product names are trademarks or registered trademarks of their respective companies.

## Revision History

Revisions of this manual include the following:

<b>Revision</b>	<b>Date</b>
000 (Preliminary)	April 1993
001	May 1993
002	May 1994

Exabyte Corporation  
1685 38th Street  
Boulder, Colorado 80301  
(303) 442-4333

510505-002

## Product Warranty Caution

The EXB-8205, EXB-8205XL, EXB-8505, and EXB-8505XL 8mm Cartridge Tape Subsystems (tape drives) are warranted to be free from defects in materials, parts, and workmanship and will conform to the current product specifications upon delivery. **For the specific details of your warranty, refer to your sales contract or contact the company from which the tape drive was purchased.**

The warranty for the tape drive shall not apply to failures caused by:

- Physical abuse or use not consistent with the operating instructions or product specifications provided by Exabyte's personnel or agent for the applicable equipment.
- Use of any type of cleaning material other than an Exabyte 8mm Cleaning Cartridge (or an Exabyte-approved cleaning cartridge).
- Modifications by other than Exabyte's personnel or agent in any way other than those approved by Exabyte, provided the warranty shall not be voided by the repair or replacement of parts or the attachment of items in the manner described in maintenance or installation instructions provided by Exabyte.
- Repair by other than Exabyte's personnel or agent in a manner contrary to the maintenance instructions provided by Exabyte.
- Removal of the Exabyte serial number tag.
- Physical abuse due to improper packaging of returns.

### CAUTION

Returning the tape drive in unauthorized packaging may damage the unit and void the warranty.

If you are returning the tape drive for repair, package it in its original packaging (or in replacement packaging obtained from your vendor). Refer to the packing instructions in *EXB-8205 and EXB-8505 Installation and Operation*.

If problems with the tape drive occur, contact your maintenance organization; do not void the product warranty by allowing untrained or unauthorized personnel to attempt repairs.

## Changes and Enhancements to This Manual

This revision (510505-002) of EXB-8205 and EXB-8505 8mm Cartridge Tape Subsystems Integration and Optimization for Standard and eXtended-Length (XL) Configurations replaces the EXB-8205 and EXB-8505 Integration and Optimization manual. This manual includes the following changes and enhancements:

- Information for the “eXtended-Length” (XL) configurations of the EXB-8205 and EXB-8505 has been included. Where differences exist among these products, these differences are noted.
- Information about the new EXATAPE 160m XL 8mm Data Cartridge, which is designed for use in the XL tape drives, has been included.
- The list of phone numbers for Exabyte support has been updated and expanded.
- The information about terminating the SCSI bus and setting the SCSI ID has been updated.
- The recommendations for using the Exabyte 8mm Cleaning Cartridge in half-high tape drives have been revised.
- Information about how to obtain an up-to-date list of software that supports the half-high tape drives has been added.
- Guidelines for adding XL support to an existing half-high driver program have been provided.
- Times for various tape drive activities that must be accounted for in a driver program have been added.
- Compatibility information for all EXATAPE 8mm Data Cartridges has been added.

# Contents

Welcome	xi
<b>1 Exabyte Support</b>	<b>1-1</b>
<b>2 Introduction to Half-High Tape Drives</b>	<b>2-1</b>
2.1 Exabyte Half-High Tape Drives Compared to Full-High Tape Drives . . . . .	2-3
2.2 The EXB-8205XL and EXB-8505XL . . . . .	2-4
2.3 Data Format Features . . . . .	2-5
2.4 Tape Drive Customization . . . . .	2-7
Ordering EEPROM Options . . . . .	2-7
2.5 Sample Configurations . . . . .	2-8
Single Host with a Tape Drive . . . . .	2-8
Single Host with a Tape Drive and Additional Devices . . . . .	2-9
Single Host with a Tape Drive and Additional Devices on Multiple SCSI Buses . . . . .	2-10
Multiple-Host LAN with a Tape Drive and Additional Devices . . . . .	2-11
2.6 Tape Drives in Changing and Expanding Configurations: an Example . . . . .	2-12
2.7 Tape Drives and Hierarchical Storage Management . . . . .	2-14
<b>3 Product Testing</b>	<b>3-1</b>
3.1 Types of Tests . . . . .	3-2
3.2 DVT Tests . . . . .	3-3
3.3 Performance at Stress Conditions Test . . . . .	3-5
3.4 Availability of Test Results . . . . .	3-6
<b>4 Hardware Integration Issues</b>	<b>4-1</b>
4.1 Tape Drive Mounting Requirements . . . . .	4-2
Guidelines for Installing the Half-High Tape Drive . . . . .	4-3
4.2 Half-High Tape Drive Enclosures . . . . .	4-4
Thermal Considerations for Half-High Enclosures . . . . .	4-6
Cooling Paths in the Mini Tabletop Enclosure . . . . .	4-7
4.3 SCSI Installation Requirements . . . . .	4-8
SCSI Cable . . . . .	4-8
SCSI Cable Connector . . . . .	4-9
SCSI Bus Terminator . . . . .	4-9
4.4 Options for Setting the SCSI ID . . . . .	4-12
Setting the SCSI ID with Jumpers . . . . .	4-13
Setting the SCSI ID with a Remote Switch . . . . .	4-13

4.5 Environmental Considerations . . . . .	4-14
Temperature and Humidity . . . . .	4-14
Air Flow and Particulate Contamination . . . . .	4-15
Shock . . . . .	4-16
Vibration . . . . .	4-17
4.6 Power and Grounding Considerations . . . . .	4-18
Power Supply . . . . .	4-18
Additional Chassis Grounding . . . . .	4-18
Power Cable and Connector . . . . .	4-19
4.7 Product Compliance Standards . . . . .	4-20
<b>5 Half-High Tape Drive Maintenance</b>	<b>5-1</b>
5.1 What Causes a Tape Drive to Require Cleaning? . . . . .	5-2
5.2 Determining When to Clean the Tape Drive . . . . .	5-3
Time-to-Clean LED Indication . . . . .	5-3
REQUEST SENSE Command . . . . .	5-3
5.3 Using an Exabyte-Approved Cleaning Cartridge . . . . .	5-4
What About Other Cleaning Cartridges? . . . . .	5-4
Procedure for Cleaning a Tape Drive . . . . .	5-5
<b>6 Software Integration Issues</b>	<b>6-1</b>
6.1 Tape Drive Timing Considerations . . . . .	6-2
6.2 Converting a Full-High Driver to a Half-High Driver . . . . .	6-4
6.3 Adding XL Support to a Half-High Driver . . . . .	6-6
<b>7 SCSI Integration</b>	<b>7-1</b>
7.1 Overview of SCSI Communications . . . . .	7-2
SCSI Commands . . . . .	7-4
SCSI Command Status . . . . .	7-6
SCSI Messages . . . . .	7-7
7.2 Disconnecting from the SCSI Bus . . . . .	7-9
7.3 Optional Enhanced SCSI Bus Performance . . . . .	7-10
Integration Issues for Enhanced SCSI Performance . . . . .	7-12
7.4 Other SCSI Configuration Options . . . . .	7-13
<b>8 Optimizing the Performance of Your Tape Drive</b>	<b>8-1</b>
8.1 Optimizing the Size of Data Blocks from the Host . . . . .	8-2
Optimizing Block Size: 8200 Format . . . . .	8-3
Logical Block Packing: All Other Data Formats . . . . .	8-4
8.2 Fine-Tuning Data Transfers . . . . .	8-5
Achieving Streaming Mode . . . . .	8-6
Adjusting the Motion and Reconnect Thresholds . . . . .	8-7

8.3 Effectively Managing Data on the Tape . . . . .	8-9
Compressing Data . . . . .	8-9
Using Partitions . . . . .	8-12
Appending Data to a Previously Written Tape . . . . .	8-15
High-Speed Search—Using the SPACE Command . . . . .	8-16
High-Speed Search—Using the READ POSITION and LOCATE Commands . . . . .	8-17
Obtaining Status Information—Using the REQUEST SENSE, LOG SELECT, and LOG SENSE Commands . . . . .	8-18

## **9 Selecting and Maintaining Tapes** **9-1**

9.1 Selecting Data Cartridges . . . . .	9-2
Data-Grade Tape or Video-Grade Tape? . . . . .	9-2
What Type of Data-Grade Tape? . . . . .	9-3
Why EXATAPE 8mm Data Cartridges? . . . . .	9-3
Compatibility of EXATAPE 8mm Data Cartridges . . . . .	9-5
Conditioning Non-EXATAPE Data Cartridges . . . . .	9-6
9.2 Maximizing Tape Life by Minimizing Tape Passes . . . . .	9-7
Estimating the Number of Tape Passes . . . . .	9-8
9.3 Storing and Maintaining Archived Tapes . . . . .	9-9
Establishing and Maintaining a Suitable Environment . . . . .	9-9
Labeling the Data Cartridges and Maintaining a Storage Log . . . . .	9-11
Using the Write-Protect Switch . . . . .	9-12
Storing Data Cartridges Immediately . . . . .	9-13
Storing Data Cartridges in the Proper Position . . . . .	9-13
Replacing Data Cartridges . . . . .	9-15

## **Glossary** **G-1**

## **Index** **I-1**

# Figures

## Introduction to Half-High Tape Drives

<b>Figure 2-1</b> EXB-8505 (top) and EXB-8205 (bottom) . . . . .	2-2
<b>Figure 2-2</b> Half-high tape drive in a single-host environment . . . . .	2-8
<b>Figure 2-3</b> Half-high tape drive in a multiple-device environment . . . . .	2-9
<b>Figure 2-4</b> Half-high tape drive in a multiple SCSI-bus environment . . . . .	2-10
<b>Figure 2-5</b> Half-high tape drive in a multiple-host, multiple-device environment .	2-11
<b>Figure 2-6</b> Exabyte's PC and workstation network, showing the use of Exabyte tape drives in an expanding network environment. . . . .	2-13
<b>Figure 2-7</b> A hierarchical storage management model . . . . .	2-15
<b>Figure 2-8</b> The relationship between cost and the speed of retrieval . . . . .	2-17

## Hardware Integration Issues

<b>Figure 4-1</b> Mounting holes on the sides of the half-high tape drive . . . . .	4-2
<b>Figure 4-2</b> Mounting holes on the bottom of the half-high tape drive . . . . .	4-2
<b>Figure 4-3</b> Exabyte's Mini Tabletop Cartridge Tape Subsystems with the EXB-8505 installed . . . . .	4-4
<b>Figure 4-4</b> Card placement in the EXB-8505 (shown) and EXB-8205 . . . . .	4-6
<b>Figure 4-5</b> Air flow in the Mini Tabletop Cartridge Tape Subsystem . . . . .	4-7
<b>Figure 4-6</b> R-packs on the back of the tape drive (single-ended) . . . . .	4-10
<b>Figure 4-7</b> SCSI ID jumper block at the back of the tape drive . . . . .	4-12
<b>Figure 4-8</b> Jumper settings for the SCSI ID . . . . .	4-13
<b>Figure 4-9</b> Particulate specification for a half-high tape drive compared to a typical office . . . . .	4-15
<b>Figure 4-10</b> Location of the ground tab, grounding hole, and power connector on the back of the tape drive . . . . .	4-19

## Optimizing the Performance of Your Tape Drive

<b>Figure 8-1</b> Corresponding areas on an unpartitioned tape and a dual-partition tape . . . . .	8-12
-------------------------------------------------------------------------------------------------------	------

## Selecting and Maintaining Tapes

<b>Figure 9-1</b> EXATAPE 8mm Data Cartridges . . . . .	9-4
<b>Figure 9-2</b> Tape passes during a start/stop write operation . . . . .	9-8
<b>Figure 9-3</b> Write-protect switch on the bottom of an 8mm data cartridge . . . . .	9-12
<b>Figure 9-4</b> <b>Do not store a data cartridge on its side.</b> When the tape inside the data cartridge is "on edge," damage can result. . . . .	9-13
<b>Figure 9-5</b> Exabyte 8mm Data Cartridge Magazines . . . . .	9-14



# Tables

## Exabyte Support

<b>Table 1-1</b> How to obtain Exabyte support . . . . .	1-2
----------------------------------------------------------	-----

## Introduction to Half-High Tape Drives

<b>Table 2-1</b> A comparison of Exabyte half-high and full-high tape drives . . . . .	2-3
<b>Table 2-2</b> Maximum capacities of XL and non-XL tape drives . . . . .	2-4
<b>Table 2-3</b> Read/write compatibility of the Exabyte 8mm data formats and 8mm tape drives . . . . .	2-5
<b>Table 2-4</b> Data format features . . . . .	2-6

## Product Testing

<b>Table 3-1</b> Exabyte reliability tests . . . . .	3-2
<b>Table 3-2</b> Tests performed during DVT . . . . .	3-3
<b>Table 3-3</b> Tests performed during the Performance at Stress Conditions test . . . . .	3-5

## Hardware Integration Issues

<b>Table 4-1</b> Environmental specifications . . . . .	4-14
<b>Table 4-2</b> Maximum particulate counts for half-high tape drive operation . . . . .	4-15
<b>Table 4-3</b> Shock specifications . . . . .	4-16
<b>Table 4-4</b> Vibration specifications . . . . .	4-17

## Software Integration Issues

<b>Table 6-1</b> Timing considerations for tape drive applications . . . . .	6-2
<b>Table 6-2</b> Converting a full-high driver to a half-high driver . . . . .	6-4
<b>Table 6-3</b> Adding XL support to a half-high driver . . . . .	6-6

## SCSI Integration

<b>Table 7-1</b> Overview of supported SCSI commands, status information, and messages . . . . .	7-2
<b>Table 7-2</b> Supported SCSI commands . . . . .	7-4
<b>Table 7-3</b> Supported SCSI command statuses . . . . .	7-6
<b>Table 7-4</b> Supported SCSI messages . . . . .	7-7
<b>Table 7-5</b> Example of how the drive supports disconnect during a read operation . . . . .	7-9
<b>Table 7-6</b> EEPROM options for enhanced SCSI bus performance . . . . .	7-11
<b>Table 7-7</b> EEPROM options for customizing the SCSI configuration . . . . .	7-13

## Optimizing the Performance of Your Tape Drive

<b>Table 8-1</b>	Host data transfer rates required for streaming data . . . . .	8-6
<b>Table 8-2</b>	Summary of motion and reconnect thresholds . . . . .	8-7
<b>Table 8-3</b>	Where to set the motion threshold and reconnect threshold . . . . .	8-8
<b>Table 8-4</b>	Where you can append new data on a previously written tape . . . . .	8-15
<b>Table 8-5</b>	High-speed search operations using the SPACE command . . . . .	8-16

## Selecting and Maintaining Tapes

<b>Table 9-1</b>	Compatibility of EXATAPE 8mm Data Cartridges and Exabyte 8mm tape drives . . . . .	9-5
<b>Table 9-2</b>	Number of tape passes associated with various types of tape activity . . .	9-8
<b>Table 9-3</b>	Recommended temperature and humidity for data cartridge storage . .	9-10

# Welcome

---

This manual provides information for integrating the EXABYTE® EXB-8205 or EXB-8505 8mm Cartridge Tape Subsystem (tape drive) into a product line. It also provides information for integrating the “eXtended-Length” (XL) configurations of these tape drives (the EXB-8205XL and EXB-8505XL).

By discussing the specific issues that you need to consider as you evaluate, install, and design applications for a half-high 8mm tape drive, this manual helps to ensure that you will achieve positive results during the integration process.

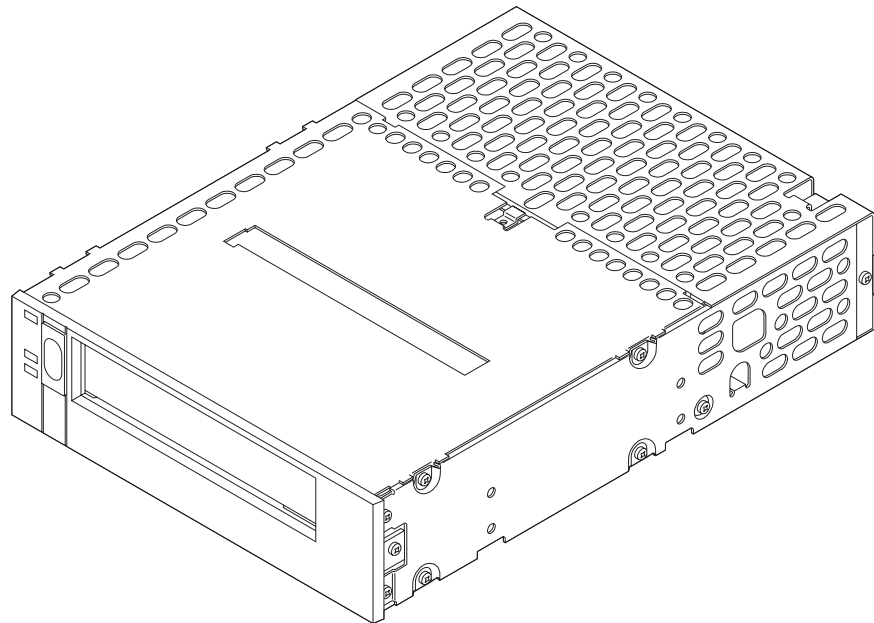

To help you through the integration process, this manual presents the following information:

- Chapter 1, “Exabyte Support,” describes the types of support available from Exabyte and provides a list of who to contact for specific information.
- Chapter 2, “Introduction to Half-High Tape Drives,” summarizes the important features of the EXB-8205, EXB-8505, EXB-8205XL, and EXB-8505XL and provides examples of how half-high tape drives fit into a variety of configurations. It also provides an overview of the principles of hierarchical storage management and explains how tape drives fit into this highly effective data storage model.
- Chapter 3, “Product Testing,” describes the different types of tests performed throughout the design and manufacture of tape drives and explains how to obtain test results from Exabyte that will shorten the integration process.
- Chapter 4, “Hardware Integration Issues,” discusses tape drive mounting requirements; thermal considerations for drive enclosures; SCSI installation requirements; environmental limits for temperature, humidity, and particulate contamination; and power and safety requirements.
- Chapter 5, “Half-High Tape Drive Maintenance,” discusses the cleaning requirements of a tape drive and describes the proper cleaning procedure.
- Chapter 6, “Software Integration Issues,” discusses issues you must consider when creating a new driver program, converting a driver program, or adding support for one of the XL tape drives.
- Chapter 7, “SCSI Integration,” provides an overview of the Small Computer System Interface (SCSI) implemented by the tape drives and discusses driver integration issues and options for customizing your SCSI configuration.
- Chapter 8, “Optimizing the Performance of Your Tape Drive,” provides guidelines to help you maximize the amount of data you can store with your drive and provide for easy access to that data.
- Chapter 9, “Selecting and Maintaining Tapes,” explains how to select quality data cartridges, maximize tape life by minimizing tape passes, and store and maintain tapes for maximum shelf life and data integrity.

## Special Information

---

Special information in this manual is highlighted in the following ways:

**Note:** *Notes* provide hints or suggestions about the topic or procedure being discussed.

---

**Important** Text next to the heading “Important” provides information that will help you successfully complete a procedure or avoid additional steps in a procedure.

---

### CAUTION

Boxed text under the heading “CAUTION” provides information you must know to avoid damaging the tape drive.

### WARNING

Boxed text under the heading “WARNING” provides information you must know to avoid personal injury.

## Related Publications

---

For additional information, refer to the following publications:

### EXB-8205, EXB-8205XL, EXB-8505, and EXB-8505XL 8mm Cartridge Tape Subsystems

- *EXB-8205 and EXB-8505 8mm Cartridge Tape Subsystems Product Specification for Standard and eXtended-Length Configurations*, 510504
- *EXB-8205 and EXB-8505 8mm Cartridge Tape Subsystems SCSI Reference for Standard and eXtended-Length Configurations*, 510503
- *EXB-8205 and EXB-8505 8mm Cartridge Tape Subsystems Installation and Operation for Standard and eXtended-Length Configurations*, 302967

### Libraries and Enclosures

- *EXB-210 8mm Library SCSI Reference*, 510806
- *EXB-210 8mm Library Product Specification*, 510807
- *EXB-210 8mm Library Operator's Guide*, 510808
- *EXB-210 8mm Library Error Codes*, 510809
- *EXB-210 8mm Library Installation*, 510810
- *Mini Tabletop 8mm Cartridge Tape Subsystem Installation*, 520156
- *Mini Tabletop 8mm Cartridge Tape Subsystem Product Specification*, 520154

### CTS Monitor

- *CTS Monitor Getting Started*, 510206

### Standards

- *ANSI Small Computer System Interface (SCSI)*, X3.131-1989
- *ANSI Small Computer System Interface-2 (SCSI-2)*, X3.131-1990
- *ANSI/ISO/IEC 11319, Information Technology—8mm Wide Magnetic Tape Cartridge for Information Interchange—Helical Scan Recording*
- *ISO/IEC 12246 Information Technology—8mm Wide Magnetic Tape Cartridge Dual Azimuth Format for Information Interchange—Helical Scan Recording*

# 1

## Exabyte Support

The first thing you need to know as you begin to integrate a half-high tape drive is what type of support you can obtain from Exabyte and how to contact us. Table 1-1, starting on the following page, is a quick guide to Exabyte support.

In addition, you may want to know which software vendors already provide packages that support Exabyte half-high tape drives. On page 1-4, a partial listing of these software vendors is provided. An up-to-date list is available from your Exabyte account manager.

**Table 1-1** How to obtain Exabyte support

Type of support	Who the support is available to	How to obtain support
<b>Sales</b>	<b>Anyone</b> can call with questions about who to buy from.	<p>Call Exabyte Regional Sales Administrators at: 1-800-EXABYTE (1-800-392-2983) (913) 492-6002</p> <p>Or, in the following locations, call: Western US: (714) 582-5211 Central US: (708) 953-8665 Eastern US: (407) 352-5622 Canada: (416) 744-6006 Scotland: (44) 324-564564 Germany: (49) 69-590295 The Netherlands: (31) 3403-51347 England: (44) 492-874855 France: (33) 1-69411617 Singapore: (65) 2716331 Japan: (81) 3-32372831</p>
<b>Contract customer support</b>	<b>Exabyte contract customers</b> can obtain information about products, media, publications, spare parts, repair service, and marketing information. A complete support package is designed for each contract customer.	<p>Contact your account manager.</p> <p><b>Note:</b> All inquiries or problems for contract customers are handled by their account managers.</p>
<b>Non-contract customer support</b>	<b>Anyone</b> can quickly obtain product data, media, cleaning cartridges, publications, spare parts, and repair service for any Exabyte product.	<p>Call Exabyte Direct Sales at: 1-800-EXATAPE (1-800-392-8273) (303) 442-4333 Fax: (303) 447-7689</p> <p>Call Exabyte Direct Service at: 1-800-447-3920 (303) 442-4333 Fax RMA (return materials authorization) requests to: (303) 447-7199</p>



Type of support	Who the support is available to	How to obtain support
<b>Technical Support</b>	<b>Anyone</b> can obtain technical support from the corporate or regional Technical Support offices. Personalized assistance from Technical Support engineers includes integration help and troubleshooting guidance.	<p>Call corporate Technical Support at: 1-800-445-7736 (303) 447-7292</p> <p>Call end user and distribution customer Technical Support at: 1-800-825-4727 (913) 492-6002</p> <p>Call European Technical Support at: (31) 3403-51347</p> <p>Call Pacific Rim Technical Support at: (65) 2716331</p>
<b>Technical Support Bulletin Board</b>	<p><b>Anyone</b> with a telecommunications setup can use the electronic bulletin board to receive information about the latest firmware levels, manual revisions, training, and all Technical Bulletins.</p> <p>In addition, customers can use the bulletin board to send diagnostic information, such as SCSI trace data, to Technical Support for analysis.</p>	<p>Dial into the corporate Technical Support bulletin board at: (303) 447-7100 Bulletin board nickname: Banana Boat System Software: Galacticomm Modem: v.32/v.42bis (up to 9600/14400 baud) Setup: 8 - none - 1</p> <p>Dial into the European Technical Support bulletin board at: (31) 3403-51258 Software: Maximus Modem: v.32/v.42bis (up to 9600/14400 baud) Setup: 8 - none - 1</p> <p>At login, first-time users can define a unique user ID and password.</p>
<b>Technical Support Training</b>	<b>Anyone</b> can obtain information about training for any Exabyte product.	<p>Call corporate Technical Support Training at: (303) 447-7292</p> <p>Call European Technical Support Training at: (31) 3403-51347</p> <p>Call Pacific Rim Technical Support Training at: (65) 2716331</p>

The following is a partial list of software vendors that have developed applications that support Exabyte half-high tape drives. For a comprehensive list of software packages and a compatibility chart, contact your Exabyte account manager.

- Arcada Software
- Banyan
- Central Point Software
- Cheyenne Software
- Corel Corporation
- Dantz Development
- Data Visual
- Diversified I/O
- Emerald Systems
- Gazelle Systems
- IBM
- Legato Systems
- Microsoft
- Mountain Network Solutions
- Novastor
- Novell
- Optima Technology
- Palindrome
- PCPC
- Performance Technology
- Raxon Software
- SCO
- Surf City Software
- Sunsoft
- Symantec
- Systems Enhancements
- Sytron
- TapeDisk
- Trantor

# 2

## Introduction to Half-High Tape Drives

The following is an overview of the important features of the EXB-8205 and EXB-8505 and an introduction to the “eXtended-Length” configurations of these tape drives (the EXB-8205XL and EXB-8505XL).

The features of the EXB-8205, EXB-8505, and XL drives are compared with Exabyte’s full-high 8mm tape drives (the EXB-8200, EXB-8200SX, EXB-8500, and EXB-8500c). Data format and customization features of the half-high tape drives are highlighted, and examples of configurations in which these drives provide effective backup are discussed. Finally, an overview of hierarchical storage management, a data storage model in which Exabyte tape drives are highly effective, is provided.

The EXB-8205 and EXB-8505, shown in Figure 2-1, are similar in appearance. The only difference is that the EXB-8205's LEDs are vertical, while the EXB-8505's LEDs are horizontal.

The EXB-8205XL and EXB-8505XL (described in Section 2.2) are identical to the non-XL drives except that the XL drives have a raised diamond pattern on the unload button. The non-XL drives have a smooth unload button with an oval-shaped indentation.

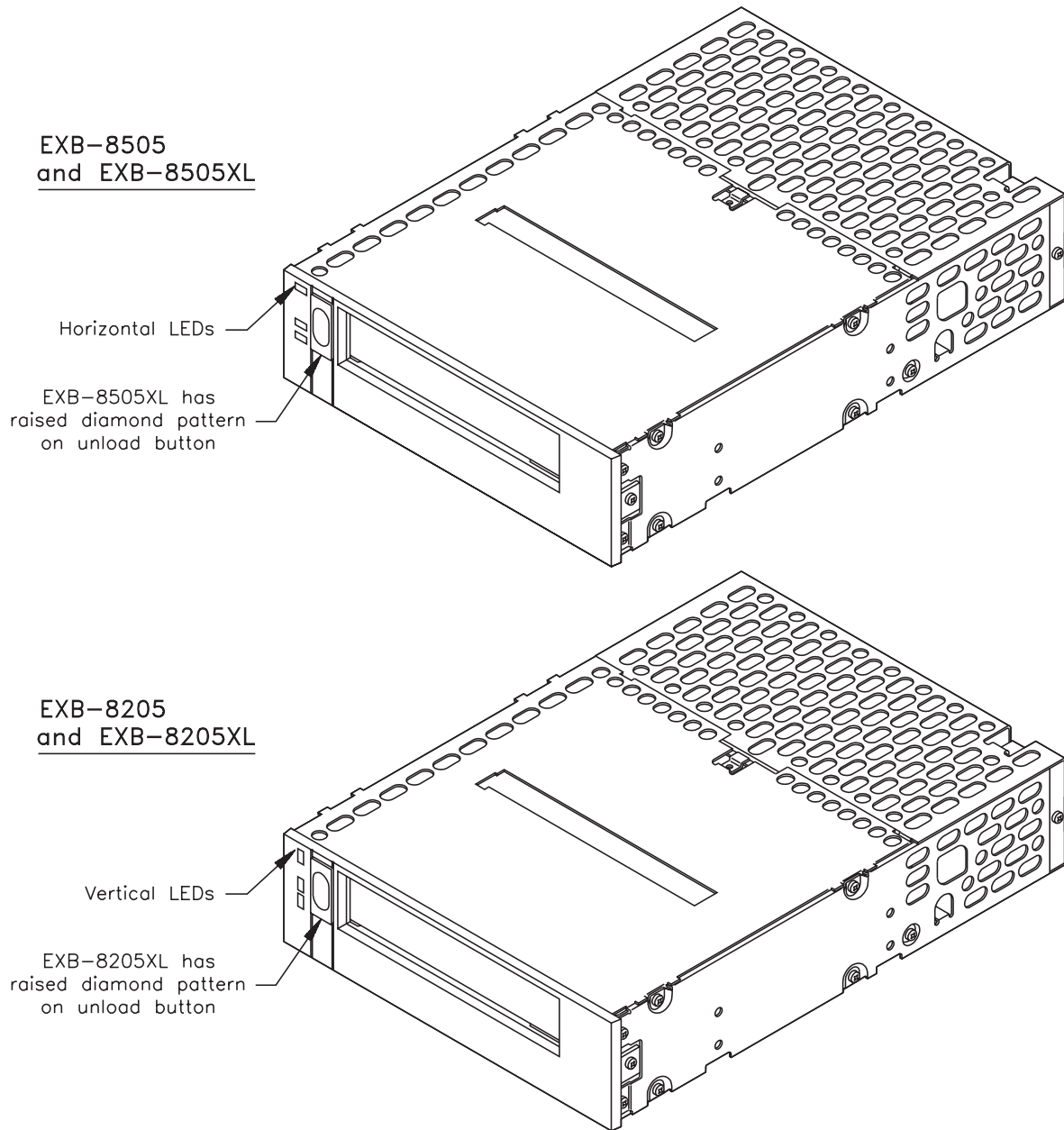

**Figure 2-1** EXB-8505 (top) and EXB-8205 (bottom)

## 2.1 Exabyte Half-High Tape Drives Compared to Full-High Tape Drives

Table 2-1 is a quick comparison of the half-high drives (EXB-8205, EXB-8505, and XL drives) and the full-high drives (EXB-8200, EXB-8200SX, EXB-8500, and EXB-8500c).

**Table 2-1** A comparison of Exabyte half-high and full-high tape drives

	Form factor	Data formats used	Buffer size	Data transfer rate <sup>a</sup>	Search speed	Supports synchronous data transfer	Time-to-Clean LED	Compression
<b>EXB-8505 and EXB-8505XL</b>	Half-high 5.25 inches	8200 8200c 8500 8500c	1.0 MByte	1.0 MByte per second <sup>b</sup>	75X normal (8500c, 8500, and 8200c formats) 10X normal (8200 format)	yes	yes	yes
<b>EXB-8205 and EXB-8205XL</b>		8200 8200c		500 KBytes per second <sup>b</sup>	75X normal (8200c format) 10X normal (8200 format)			
<b>EXB-8500c</b>	Full-high 5.25 inches	8200 8200c 8500 8500c	1.0 MByte	1.0 MByte per second <sup>b</sup>	75X normal (8500c, 8500, and 8200c formats) 10X normal (8200 format)	yes	no	yes
<b>EXB-8500</b>		8200 8500		500 KBytes per second	75X normal (8500 format) 10X normal (8200 format)			no
<b>EXB-8200SX</b>		8200	256 KBytes	246 KBytes per second	75X normal	no	no	no
<b>EXB-8200</b>				10X normal				

<sup>a</sup>These figures represent the maximum sustained data transfer rate.

<sup>b</sup>These figures assume a 2:1 data compression ratio.

## 2.2 The EXB-8205XL and EXB-8505XL

The “eXtended-Length” (XL) configurations of the EXB-8205 and EXB-8505 (the EXB-8205XL and EXB-8505XL) provide extra data capacity by supporting the extended-length EXATAPE™ 160m XL 8mm Data Cartridge. The XL tape drives are fully compatible with the non-XL tape drives; each XL drive supports all of the tape sizes and data formats supported by the corresponding non-XL drive.

**Important** EXATAPE 160m XL 8mm Data Cartridges are intended for use in the EXB-8205XL and EXB-8505XL only. The EXB-8205 and EXB-8505 do not support 160m data cartridges. See page 9-5 for detailed information about using the 160m XL data cartridge.

Table 2-2 compares the capacities of the XL tape drives and non-XL tape drives on the longest tape size supported by each.

**Table 2-2** Maximum capacities of XL and non-XL tape drives

	Maximum capacity in the following data format...			
	8200 format	8200c format*	8500 format	8500c format*
<b>EXB-8205 using a 112m tape</b>	2.5 GBytes	5.0 GBytes	n/a	
<b>EXB-8205XL using a 160m XL tape</b>	3.5 GBytes	7.0 GBytes		
<b>EXB-8505 using a 112m tape</b>	2.5 GBytes	5.0 GBytes	5.0 GBytes	10.0 GBytes
<b>EXB-8505XL using a 160m XL tape</b>	3.5 GBytes	7.0 GBytes	7.0 GBytes	14.0 GBytes

\* Assumes a 2:1 data compression ratio.

**Note:** You can distinguish an XL tape drive from a non-XL tape drive by checking the unload button. The XL drives have a raised diamond pattern on the unload button.

## 2.3 Data Format Features

The EXB-8205 and EXB-8205XL write data in two formats:

- 8200
- 8200c (compressed)

The EXB-8505 and EXB-8505XL write data in four formats:

- 8200
- 8200c (compressed)
- 8500
- 8500c (compressed)

Table 2-3 shows the read/write compatibility of these data formats and all Exabyte 8mm tape drives.

**Table 2-3** Read/write compatibility of the Exabyte 8mm data formats and 8mm tape drives

This data format...	Can be written and read by an...					
	EXB-8200	EXB-8200SX	EXB-8500	EXB-8500c	EXB-8205 and EXB-8205XL	EXB-8505 and EXB-8505XL
8200 format	✓	✓	✓	✓	✓	✓
8200c format				✓	✓	✓
8500 format			✓	✓		✓
8500c format				✓		✓

Table 2-4 compares the data format features of the half-high tape drives.

**Table 2-4** Data format features

	8200 format	8200c format*	8500 format (EXB-8505 and EXB-8505XL)	8500c format* (EXB-8505 and EXB-8505XL)
<b>Maximum sustained data transfer rate</b>	262 KBytes/sec	500 KBytes/sec		1.0 MByte/sec
<b>Maximum capacity on 112m tape</b>	2.5 GBytes	5.0 GBytes		10.0 GBytes
<b>Maximum capacity on 160m XL tape (XL configurations only)</b>	3.5 GBytes	7.0 GBytes		14.0 GBytes
<b>Track structure</b>	Helical scan: One write head writes a single data track with a $-10^\circ$ azimuth.		Helical scan: Two write heads write two overlapping data tracks. Track 1 = $+20^\circ$ azimuth. Track 2 = $-10^\circ$ azimuth.	
<b>Supports partitions</b>	no			yes
<b>Supports setmarks</b>	no			yes
<b>Long filemarks</b>	270 tracks (2,160 KBytes)		6 tracks (48 KBytes)	
<b>Short filemarks</b>	23 tracks (184 KBytes)	one 1-KByte physical block		
<b>Setmarks</b>	no			yes—6 tracks (48 KBytes)
<b>EOD mark</b>	no	yes—849 tracks (249 gap tracks + 600 EOD tracks)	yes—602 tracks (2 gap tracks + 600 EOD tracks)	
<b>Search fields</b>	no	yes		
<b>Logical block packing</b>	no	yes		

\*Assumes a data compression ratio of 2:1.



## 2.4 Tape Drive Customization

---

When a half-high tape drive is manufactured, a number of default values can be programmed into its electronically erasable programmable read-only memory (EEPROM). These default values, called *EEPROM options*, can be used to customize a number of drive features, including:

- **Power-on defaults for SCSI commands.** These include settings for various fields of the MODE SELECT command, such as the Density Code, Block Length, and Cartridge Type.
- **Permanent SCSI command operation features.** These include options for controlling how INQUIRY, MODE SELECT, MODE SENSE, REQUEST SENSE, and other SCSI commands operate.
- **Hardware operation options.** These include options for controlling how the unload button works and how the drive autosizes a tape.
- **SCSI configuration options.** These include options for enabling disconnects from the SCSI bus, parity checking, and command queuing.

Some of the available EEPROM options are discussed in this manual. An order form listing all of the available EEPROM options is available from your account manager.

### Ordering EEPROM Options

---

When you order a half-high tape drive, you can select which, if any, EEPROM options you want to change from their standard settings. Using the information on your EEPROM option order form, Exabyte will create a customized *EEPROM image* containing all of your selections. Once you have defined your EEPROM requirements, each half-high tape drive you purchase will be factory-configured with your customized EEPROM image.

Contact your account manager to order your EEPROM options. If you need help in selecting EEPROM options, contact Exabyte Technical Support.

## 2.5 Sample Configurations

---

The following are a few examples of configurations in which half-high tape drives can provide effective data backup. Half-high tape drives adapt well to a wide variety of configurations. The drives come in either single-ended or differential SCSI models, operate with a wide variety of host bus adapter cards, and run on many types of platforms through numerous backup utilities.

### Single Host with a Tape Drive

---

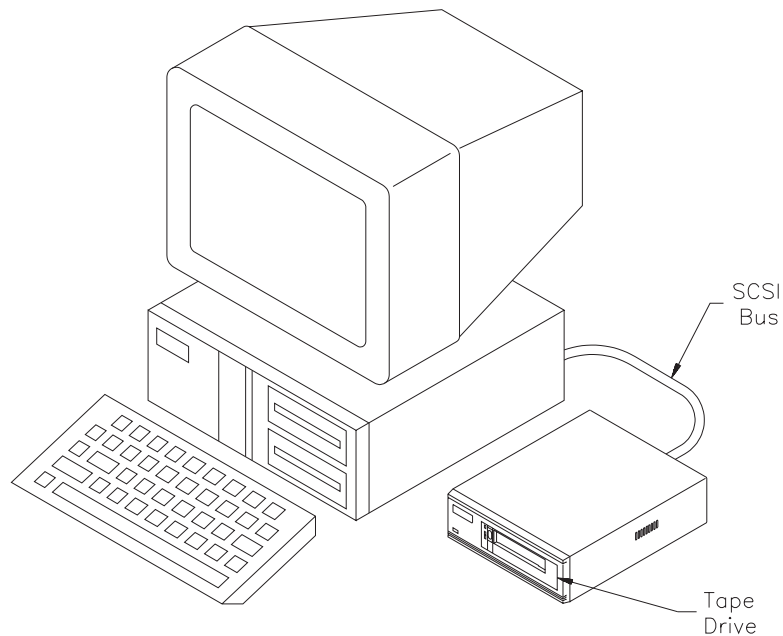

**Figure 2-2** Half-high tape drive in a single-host environment

A half-high tape drive in a single-host environment provides dedicated, secure backup for the host. Data cartridges provide inexpensive data protection for either on-site or off-site storage.

## Single Host with a Tape Drive and Additional Devices

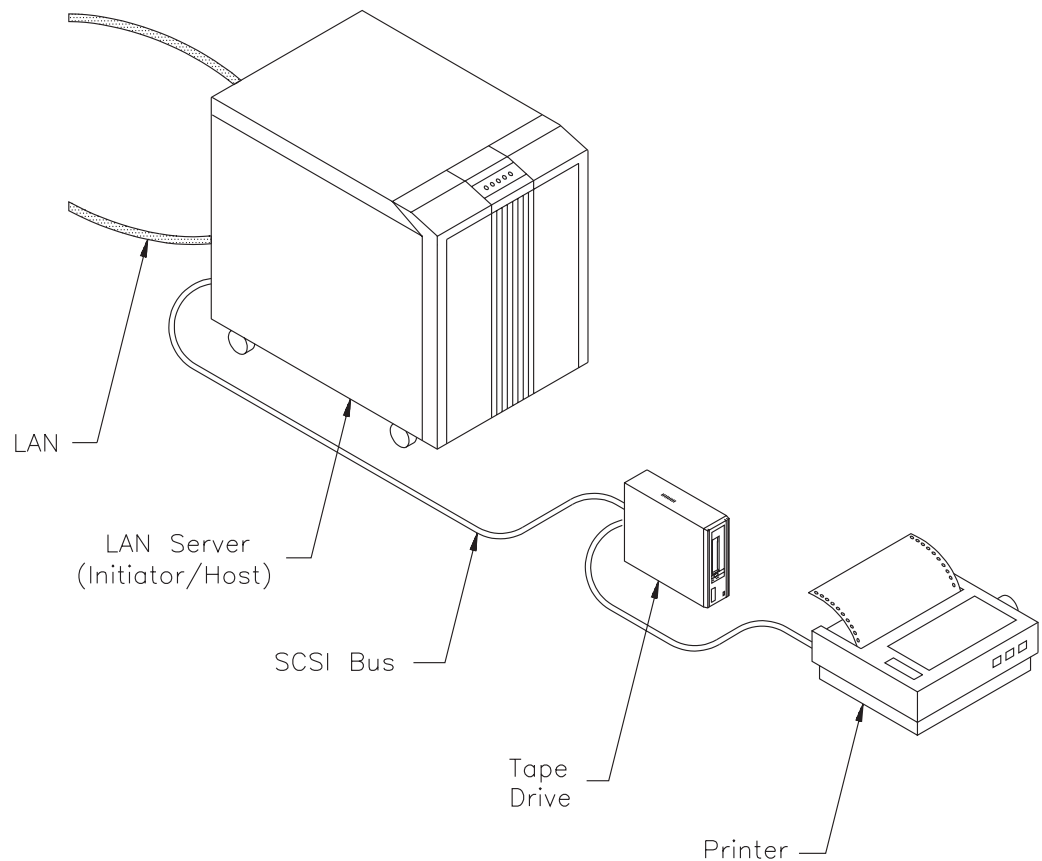

**Figure 2-3** Half-high tape drive in a multiple-device environment

A half-high tape drive in a multiple-device environment can provide dedicated backup for the host and, if the host is attached to a local area network (LAN), backup for other devices on the network.

Because the tape drive requires very little internal SCSI cable length, there is ample room for additional devices on the bus. Through its disconnect option, the tape drive permits easy bus access for the other bus devices.

## Single Host with a Tape Drive and Additional Devices on Multiple SCSI Buses

---

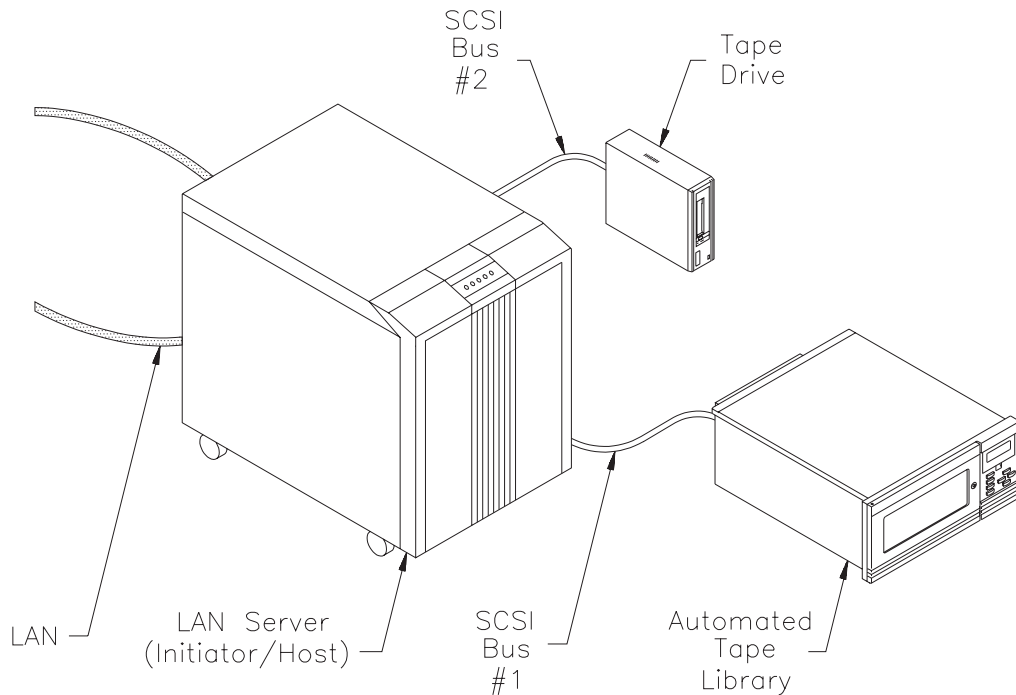

**Figure 2-4** Half-high tape drive in a multiple SCSI-bus environment

Half-high tape drives in a multiple SCSI-bus environment can provide backup for the host, devices on the LAN, and other devices on either SCSI bus. As shown in the figure, a tape drive might be located on one SCSI bus and an automated tape library on another. Files can be retrieved through one device without interrupting archiving operations on the other device.

## Multiple-Host LAN with a Tape Drive and Additional Devices

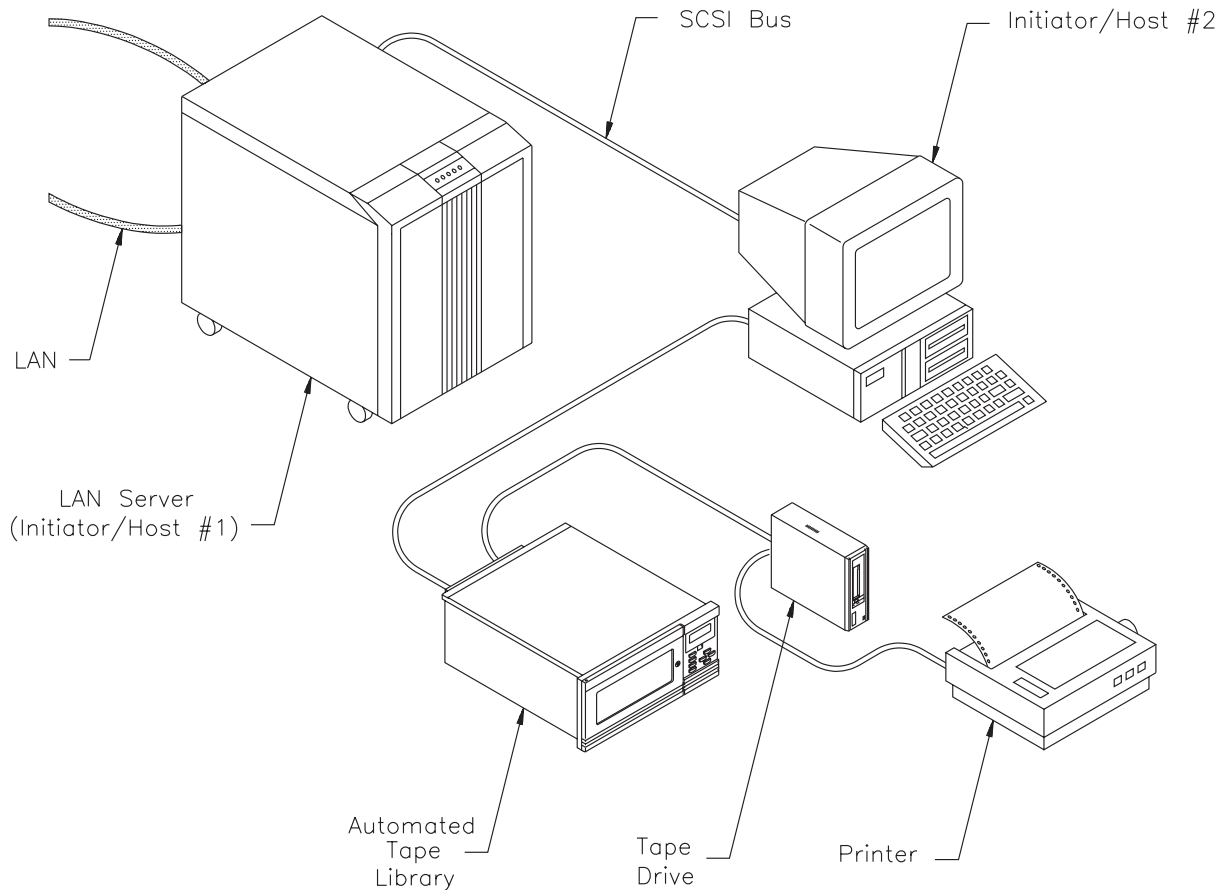

**Figure 2-5** Half-high tape drive in a multiple-host, multiple-device environment

Half-high tape drives in a multiple-host, multiple-device environment can provide backup for any or all hosts, devices on the LAN, or other devices on the SCSI bus. As an example, a tape drive can provide dedicated backup for a specific device, while an automated tape library provides backup for the entire network.

## 2.6 Tape Drives in Changing and Expanding Configurations: an Example

---

As a company's computing needs evolve, system administrators can integrate Exabyte tape drive back-up solutions into changing and expanding network configurations.

A good example of such an expanding configuration is Exabyte Corporation's own local area network (LAN) and wide area network (WAN). Shown in Figure 2-6, the Exabyte LAN in Boulder, Colorado, consists of approximately 1,700 PCs and workstations attached to 15 file servers. The LAN encompasses five buildings in Boulder and provides access to approximately 250 PCs and 10 file servers in Exabyte offices around the world. The network is continually being expanded as new employees are added and new servers and applications are required.

### Distributed Backup

Throughout the Exabyte network's existence, data back-up has always been performed by Exabyte tape drives. As the network has grown, the back-up strategy for the network has evolved into a distributed approach that features the following:

- **Approximately 18 Exabyte tape drives distributed around the network to back up multiple servers.**
- **Completely unattended back-up.** Through the use of Exabyte robotic tape libraries that can process 10 cartridges, operator intervention during backup is eliminated. Restoration of data involving multiple tapes can also be performed unattended.
- **Low impact on the network.** Most back-up operations are scheduled between 2:00 AM and 5:00 AM to take advantage of low-use periods on the network. With the assistance of hub concentrators, bridges, routers, and subnets, individual areas can be backed up separately to further reduce network impact.
- **PC node-level backups for selected local hard drives.** Selected PCs in the network can be backed up individually through the local file server to an 8mm tape drive.

As this example shows, whether a network requires one backup system or multiple backup strategies, Exabyte tape drives adapt well to the ever-changing storage requirements of an evolving network.

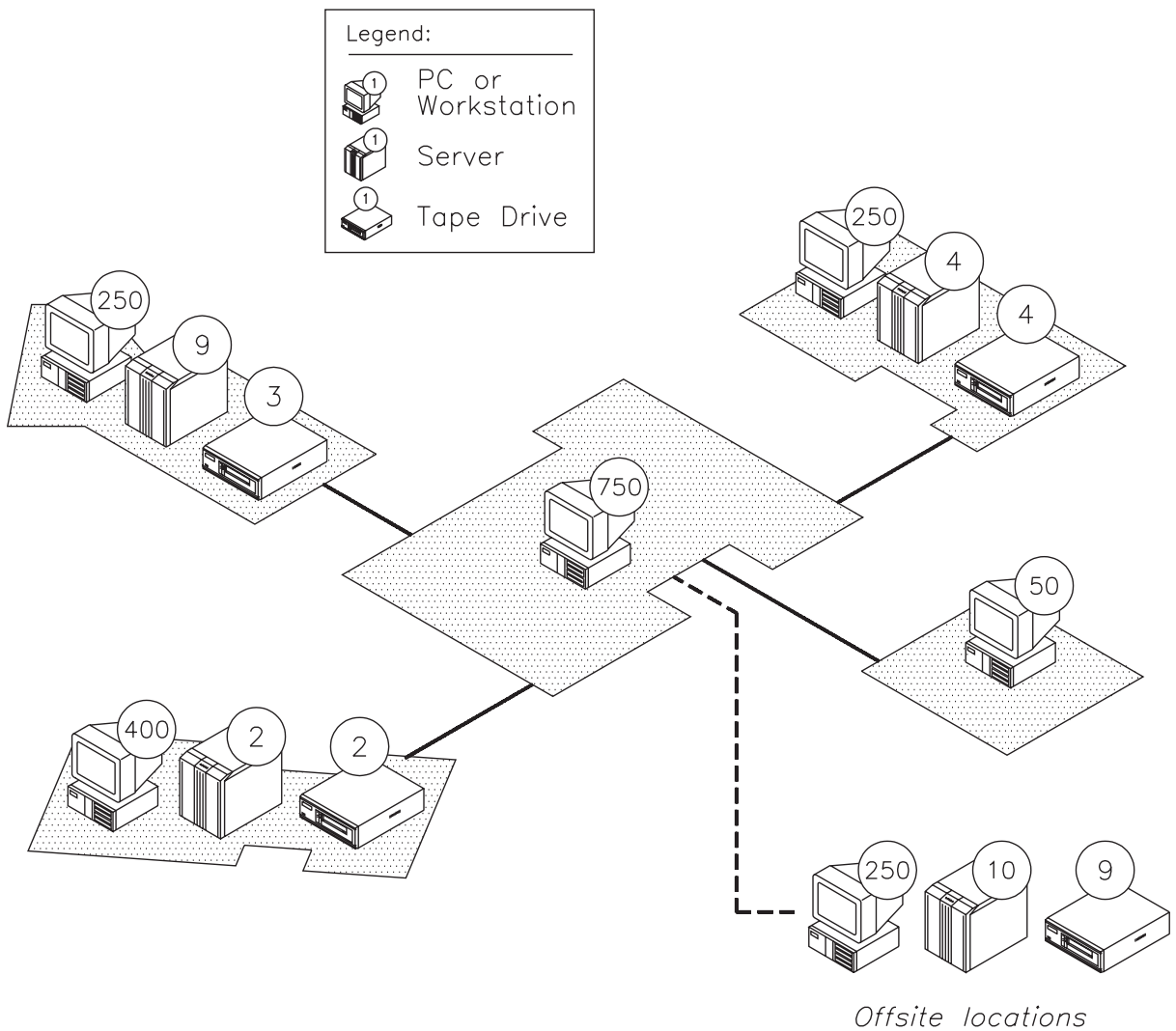

**Figure 2-6** Exabyte's PC and workstation network, showing the use of Exabyte tape drives in an expanding network environment. (Circled numbers indicate the number of each type of device in each location.)

## 2.7 Tape Drives and Hierarchical Storage Management

---

Data storage has evolved beyond simply keeping all files on a local hard disk. Effective storage and retrieval of data often requires a multi-level hardware and software strategy. This strategy, sometimes referred to as *hierarchical storage management* (HSM), has replaced simple online storage for the following reasons:

- **Increased volume of data.** The expanded processing capabilities of computer systems, combined with the proliferation of graphics, multimedia applications, and large databases, has increased the demand for data access and data storage.
- **Increased value of data.** Many businesses rely on their data to stay in business. This data must be securely and reliably stored and protected. Often, businesses require the storage of data offline and offsite in the event of a disaster.
- **High cost of online storage.** The cost of local hard disk or server storage forces most users to consider options other than online storage for infrequently used data.

Figure 2-7 is one conception of hierarchical storage management that demonstrates the role of tape drives. The figure portrays the three levels of storage that make up HSM: online, near-online, and offline. HSM requirements for standalone workstations are shown on the left side of each level, while HSM requirements for networked workstations or LANs are shown on the right side of each level.

The arrows in the figure indicate the migration of data through the storage levels. Data stored offline is retrieved through physical inventory management and becomes available as near-online storage when the data cartridge is read by the tape drive. Data management applications manage the transfer of data across the SCSI bus through the server to the workstation that has requested the data.



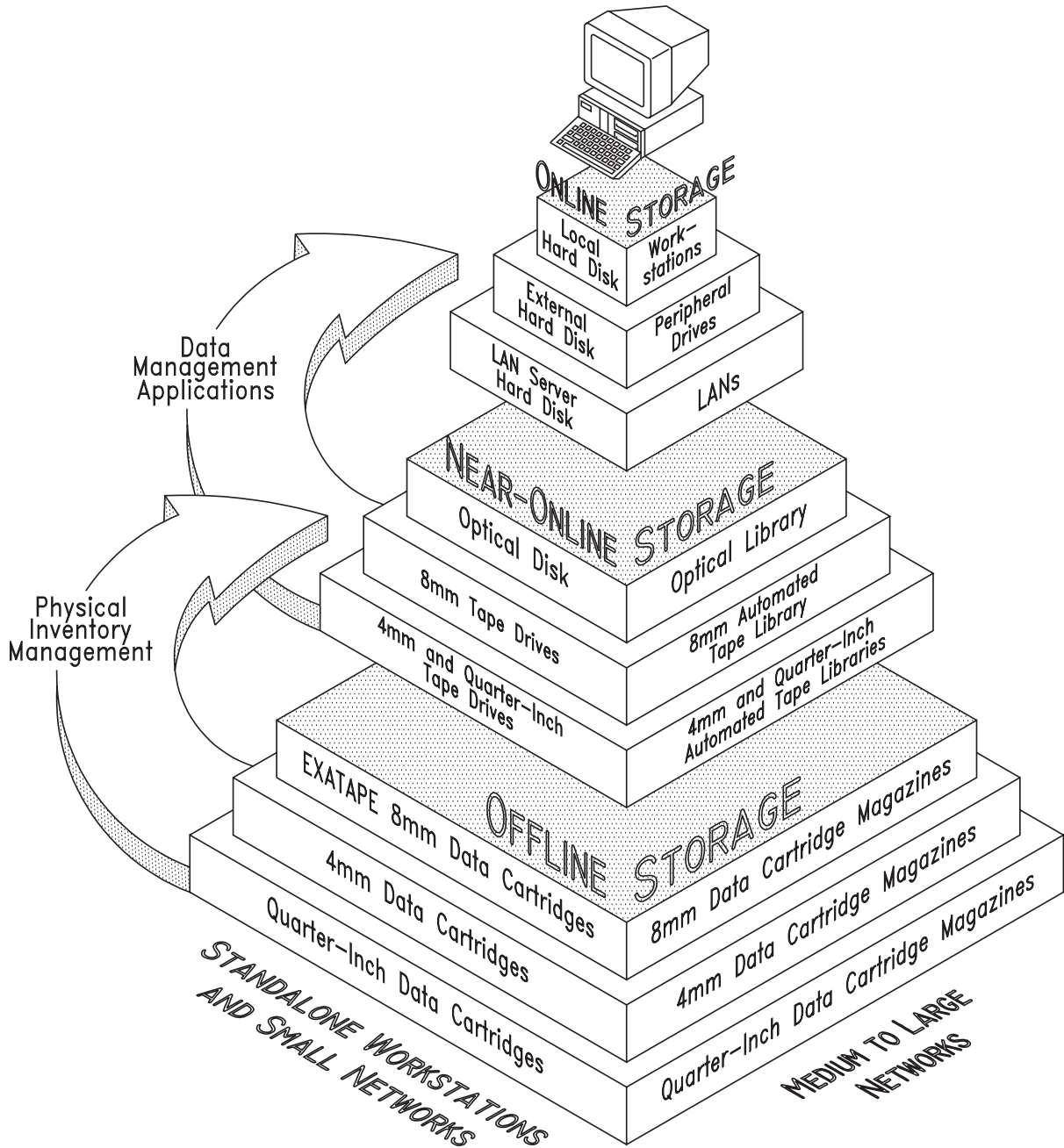

Figure 2-7 A hierarchical storage management model

### **Online Storage**

Online storage provides continuous, rapid access to data stored on a workstation, server, or external hard disk. However, the cost and maintenance of online storage is high. When a hard disk holds large amounts of data, inactive files contribute to a degradation of its performance and occupy space that could be more efficiently used for active files.

For a standalone workstation, online storage requirements are best satisfied by the local hard disk or an external hard disk added to the workstation. For a networked workstation, effective online storage is provided by other workstations, peripheral hard disks, or LAN servers.

### **Near-Online Storage**

Near-online storage provides a less expensive storage option that does not reduce performance of the hard disks and offers data retrieval without long delays. Application software manages the process of storing and retrieving files, optimizing disk performance by checking file dates and migrating inactive files to optical disk, tape drives, and disk or tape libraries.

For standalone workstations, near-online storage requirements are best satisfied by attaching a tape drive, such as the EXB-8205 or EXB-8505, to the workstation. For networked workstations, near-online storage requirements are best satisfied by attaching a combination of peripheral devices (such as an optical disk, tape drive, and automated library system).

### **Offline Storage**

The final element of HSM is offline storage. Unlike online storage, quick access is not nearly as important as reliability and low cost. Data cartridges in either 8mm, 4mm, or quarter-inch formats offer reliable long-term storage that costs significantly less per MByte than disk-based solutions.

For both standalone and networked workstations, offline storage requirements are best satisfied by secure storage of individual data cartridges. For example, the EXB-8205 and EXB-8505 use data cartridges that can be stored individually or in data cartridge magazines that hold up to ten cartridges each.

## Cost Versus Speed of Retrieval

As shown in Figure 2-8, there is a relationship between the cost of data storage and the speed of retrieval in an HSM system. Online storage options, such as local hard disks, provide rapid data access but are very expensive for large amounts of data. Offline storage options, such as data cartridges stored offsite, result in slower retrieval but are much more economical for large amounts of data.

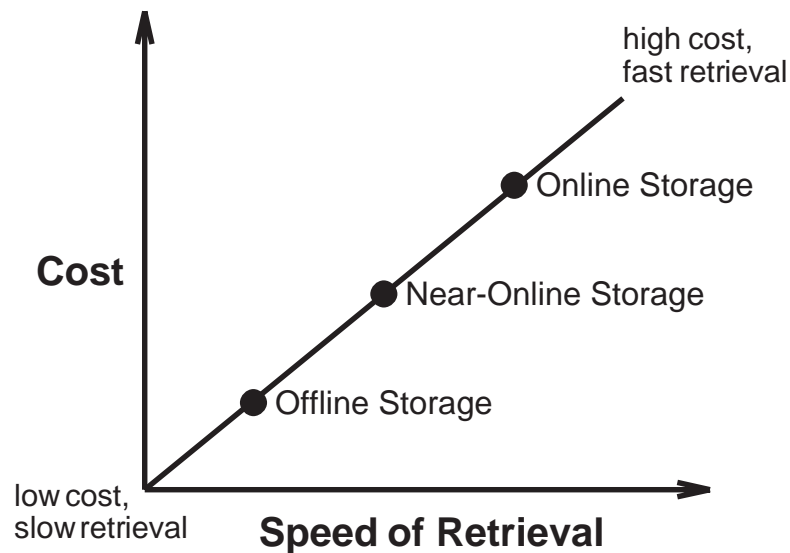

**Figure 2-8** The relationship between cost and the speed of retrieval

An effective hierarchical storage management strategy provides economical benefits to offset the inconvenience of some data not being immediately available. As demonstrated in Figure 2-7 on page 2-15, effective near-online and offline storage options include tape drives. Tape media offers a significant economic advantage over disk storage systems for near-online storage. The addition of automated tape libraries that can manage large inventories of data cartridges offers a solution for networks at significantly less cost than a storage system providing only online storage. In addition, the low cost, long shelf life, and convenience of data cartridges for offsite transport make tape media an effective solution to offline storage requirements.

## Notes:

---

# 3

## Product Testing

As a systems integrator, you are concerned with the performance and reliability of each component that you add to a system. Testing a new product typically adds a tremendous amount of time to the system integration process.

Exabyte conducts extensive testing of all its products and makes a number of the test results available to customers who integrate tape drives into their systems.

This chapter describes the types of testing Exabyte performs and provides information about how to obtain test results that can help you speed up your integration process.

## 3.1 Types of Tests

Table 3-1 is a brief overview of the types of testing that Exabyte performs on all its tape drives.

**Table 3-1** Exabyte reliability tests

Test	Purpose	Description
<b>Engineering verification testing (EVT)</b>	To aid the product development process by testing all parts of the product to make sure it meets specifications and to identify and fix problems early in the development cycle.	All prototypes of the product are tested to the limits of functionality for performance specifications, environmental requirements, safety and regulatory limits, and fail modes.
<b>Design verification testing (DVT)</b>	To verify that the product performs according to its product specifications and ANSI SCSI-2 specifications.	All phases of the product's functionality are tested, as described in Section 3.2. The test results are available to customers to help in the integration process.
<b>Process verification testing (PVT)</b>	To determine whether existing manufacturing processes can produce the product in high volume while meeting reliability specifications.	Samples of the product are pulled from inventory and subjected to stress tests that are designed to replicate a broad range of user applications and to accumulate usage hours at a high rate. MTBF (mean time between failures) is determined and compared to specifications for the product.
<b>Engineering change testing</b>	To verify that the product continues to perform according to its product specifications after engineering changes are implemented.	Any time an engineering change is made, the product's functionality is reconfirmed. Depending on the type of change, any or all of the tests performed during DVT (described in Section 3.2) may be conducted.
<b>On-going reliability testing (ORT)</b>	To continually monitor the reliability of the product and determine the lifetime of its various components.	Samples of the product are pulled from inventory and subjected to long-term performance tests that determine the life of such components as the motors, recording heads, and electronics.

## 3.2 DVT Tests

Design verification testing (DVT) consists of a wide range of tests designed to verify the product's functionality. The individual tests performed on tape drives are described in Table 3-2. Following the table, Section 3.3 describes the most critical of these tests, the "Performance at Stress Conditions" test.

**Table 3-2** Tests performed during DVT

Test	Description
<b>SCSI Specification Compliance</b>	
SCSI Command Set	Verifies that the SCSI command set implemented in the tape drive complies with ANSI specifications.
SCSI Message Set	Verifies that the SCSI message set implemented in the tape drive complies with ANSI specifications.
Unit Attention and Reset Conditions	Verifies that the tape drive reports Unit Attention after the conditions specified in the <i>EXB-8205 and EXB-8505 Product Specification</i> or the <i>EXB-8205 and EXB-8505 SCSI Reference</i> , and that the drive can be reset under the conditions specified in the Product Specification or SCSI Reference.
<b>Performance Specifications</b>	
Transfer Rate Benchmark	Verifies the data transfer rate of the tape drive, including synchronous and asynchronous data transfers, fixed-block and variable-block transfers, and transfers in all of the data formats supported by the drive.
Power Dissipation	Measures the current drawn by the tape drive on the +5V/+12V power supply lines during various operations, including power-up, tape load, tape unload, read, write, high-speed search, and rewind.
Write/Read Access Times	Verifies the write and read access times of the tape drive in all of its supported data formats. Access time is the time that elapses after the drive receives the last byte of the command CDB until it signals REQ to transfer the first byte of data across the SCSI bus.
Power Supply Noise Injection	Verifies that the tape drive will accurately read and write data when certain levels of noise are injected on its power supply lines.
<b>Tape Drive Functionality</b>	
Performance at Stress Conditions	(See Section 3.3.)
Mixed Model Data Interchange	Verifies that the tape drive is able to write tapes that are readable by other compatible Exabyte products and read tapes that are written by other compatible Exabyte products.

### 3 Product Testing

Test		Description
	Status Indicators	Verifies that the LEDs on the front panel of the tape drive accurately indicate the following states: power-on initialization, power-on self-test pass or fail, ready with tape loaded, SCSI activity, error, normal tape motion, compressed tape motion, time to clean.
<b>Environmental Specifications</b>		
	Electrostatic Discharge (ESD)	Verifies that the tape drive functions when subjected to the ESD limits specified in the <i>EXB-8205 and EXB-8505 Product Specification</i> .
	Shock, Non-operating	Verifies that the tape drive is still operable after being subjected to the shock levels specified in the <i>EXB-8205 and EXB-8505 Product Specification</i> while not operating.
	Shock, Operating	Verifies that the tape drive functions when subjected to the shock levels specified in the <i>EXB-8205 and EXB-8505 Product Specification</i> during operation.
	Vibration, Non-operating	Verifies that the tape drive is still operable after being subjected to the vibration levels specified in the <i>EXB-8205 and EXB-8505 Product Specification</i> while not operating.
	Vibration, Operating	Verifies that the tape drive functions when subjected to the vibration levels specified in the <i>EXB-8205 and EXB-8505 Product Specification</i> during operation.
	Acoustic Noise	Verifies that the tape drive does not exceed the acoustic noise limits specified in the <i>EXB-8205 and EXB-8505 Product Specification</i> .
	EMI (Electromagnetic Interference) Susceptibility	Verifies that the tape drive functions when subjected to the limits of radiated electromagnetic energy specified in the <i>EXB-8205 and EXB-8505 Product Specification</i> .
	VDE/FCC/DOC/CISPR	Verifies that the tape drive complies with the limits for radiated and conducted electrical energy defined by these specifications.
<b>Agency Approvals</b>		
	UL	Verifies that the tape drive is compliant as a component to the requirements of UL standard 1950 1st Edition, Information Technology Equipment.
	CSA	Verifies that the tape drive is compliant as a component to the requirements of CSA standard 22.2 No. 950-M89, Information Technology Equipment.
	TUV	Verifies that the tape drive is compliant as a component to the requirements of EN60950, 1990 and VDE 0805/05.90.



## 3.3 Performance at Stress Conditions Test

The Performance at Stress Conditions test is designed to simulate how a tape drive is likely to operate under a wide range of conditions. Tape Drives are run through a series of tests representing typical operation under varying conditions of stress. The stress conditions include:

- Margined +5V and +12V power supply lines ( $\pm 5\%$ )
- Noisy power supply
- Temperature and humidity extremes
- Thick tape and thin tape
- Fixed-length and variable-length logical block sizes
- Fixed and random data patterns
- Synchronous and asynchronous data transfers
- Horizontal and vertical mounting orientations
- Start/stop and streaming data transfer modes

The half-high tape drive is run through a set of trials in which all of the tests described in Table 3-3 are performed. During each trial, one or more of the stress conditions is varied to determine how the drive is affected.

**Table 3-3** Tests performed during the Performance at Stress Conditions test

Test	Description
Power-on Self-test, No Tape Installed	Verifies that the tape drive can successfully execute its power-on self-test.
Code Load Tape Functionality	Verifies that the tape drive can successfully recognize a code load tape, download the code, and eject the tape.
Serial Port Functionality	Verifies that the tape drive can successfully perform a "monitor dump" and download code through its serial port.
Cleaning Tape Recognition	Verifies that the tape drive can successfully recognize the insertion of a cleaning cartridge and perform the required cleaning routine.
Tape Load Functionality	Verifies that the tape drive can successfully load a tape and become "ready."
Power-on Self-test, Tape Installed	Verifies that the tape drive can successfully execute its power-on self-test with a tape loaded and become "ready."
Voltage Margin Guard Band	Verifies that the tape drive will accurately perform read and write operations within $\pm 5\%$ of specified voltage, and determines how far outside of this limit the drive will continue to operate.
Write/Read Error Rate Evaluation	Verifies the tape drive's write and read performance for random data patterns. All data formats supported by the drive are tested.

Test	Description
Read Interchange Error Rate Evaluation	Verifies that the tape drive is able to read tapes that are written by another compatible Exabyte tape drive.
Power Loss/Restore Data Integrity	Verifies that no recorded data will be lost as a result of a power loss during a read operation.
High-Speed Search Functionality	Verifies the tape drive's high-speed search capabilities by issuing searches to random locations on the tape

## 3.4 Availability of Test Results

---

All DVT test results are available on request from Exabyte. Results from the Performance at Stress Conditions test generally will provide you with all the information you need to predict the overall reliability of a tape drive in a wide range of operating environments. Results from the individual tests described in Table 3-2 can provide further information if you have areas of particular concern. Contact your account manager to request DVT test results.

# 4

## Hardware Integration Issues

Installing a half-high tape drive into a final product is a straightforward procedure. The tape drive provides a number of mounting options and has just a few requirements regarding SCSI setup and the operating environment. This chapter discusses the following hardware integration issues:

- Tape drive mounting requirements
- Thermal considerations for half-high enclosures
- SCSI installation requirements
- Options for setting the SCSI ID
- Environmental considerations
- Power and grounding considerations
- Product compliance standards

## 4.1 Tape Drive Mounting Requirements

A half-high tape drive can be installed in almost any location, either horizontally or vertically and in a stationary or sliding position. These drives are designed to be mounted in the standard 5.25-inch half-high form factor. If necessary, a tape drive can be installed in a larger form factor with a mounting frame (not supplied by Exabyte).

The half-high tape drive provides three sets of mounting holes: two sets on the sides (sets A and B) and one set on the bottom (set C).

Figure 4-1 and Figure 4-2 show the locations of the mounting holes.

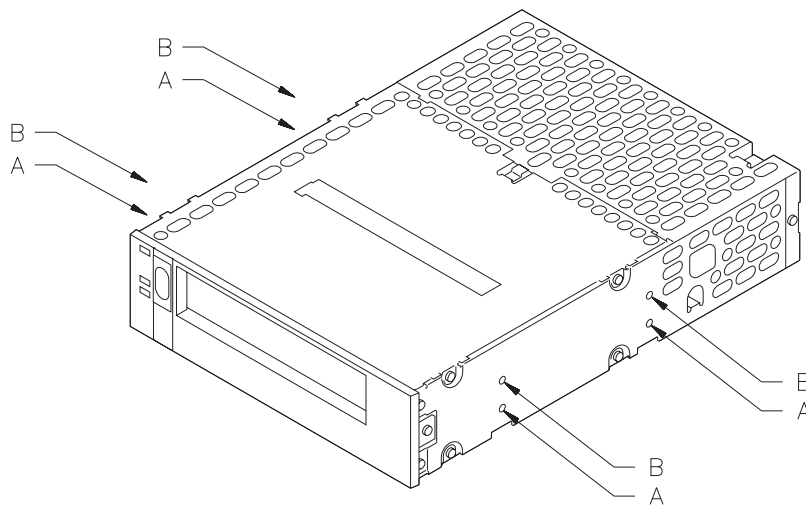

**Figure 4-1** Mounting holes on the sides of the half-high tape drive

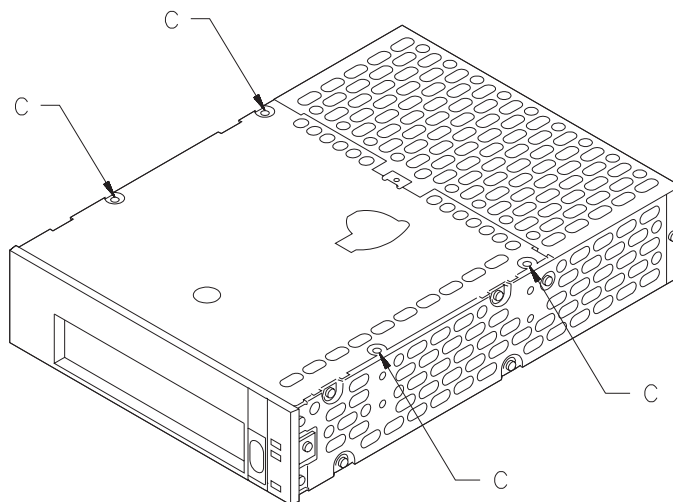

**Figure 4-2** Mounting holes on the bottom of the half-high tape drive

## Guidelines for Installing the Half-High Tape Drive

---

When you install a half-high tape drive in an enclosure, follow these guidelines:

- The mounting location must meet the environmental requirements discussed in this chapter. These requirements specify limits for operating temperature, humidity, airflow, particulate contamination, shock, and vibration.
- The tape drive must be mounted solidly and securely. To assure reliability, there must be no distortion of the tape drive's metal housing. Do not install the drive in such a way that its frame is unsupported. For example, do not hang the drive by an edge.
- You must use at least four mounting holes to secure the tape drive. It is highly recommended that you use the four holes from only one set (A, B, or C, as shown in Figures 4-1 and 4-2). Combinations of mounting holes from different sets may lead to distortion of the frame.
- Objects such as screw heads, cables, or adjacent devices must not press against the tape drive.
- The ventilation slots at the sides and top of the tape drive must be free of obstruction so that adequate airflow is provided.
- There must be sufficient space to access the front panel and operate the unload button.

Refer to the *EXB-8205 and EXB-8505 Product Specification* for detailed information about the dimensions of the drive, spacing of the mounting holes, and required screw sizes.

## 4.2 Half-High Tape Drive Enclosures

---

If you plan to create an enclosure for a half-high tape drive, it must be designed to maintain the tape path temperature within the limits indicated in the *EXB-8205 and EXB-8505 Product Specification*. You can design your own enclosure, or you can purchase the tape drive already integrated in the Exabyte Mini Tabletop 8mm Cartridge Tape Subsystem. Because the Mini Tabletop Cartridge Tape Subsystem comes with its own power supply, thermistor-controlled fan, and SCSI connectors, you do not need to spend additional development time designing an enclosure and obtaining agency approval. Figure 4-3 shows vertical, horizontal, front, and back views of the Mini Tabletop Cartridge Tape Subsystem.

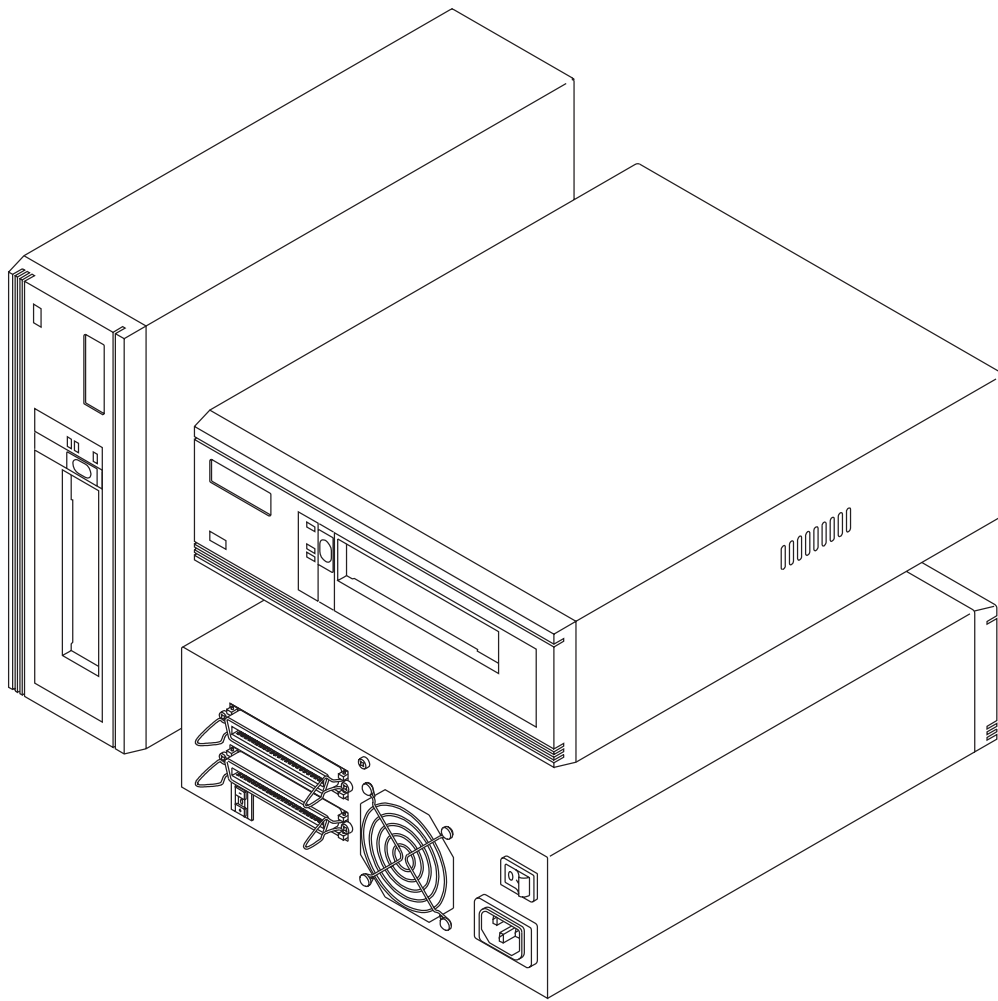

**Figure 4-3** Exabyte's Mini Tabletop Cartridge Tape Subsystems with the EXB-8505 installed

The Mini Tabletop Cartridge Tape Subsystem offers these features:

- **Configuration flexibility.** Lightweight, completely enclosed, temperature-controlled design allows either vertical or horizontal placement.
- **Power protection.** Internal, self-switching universal power supply allows continuous operation during limited power interruptions or surges. An AC line filter minimizes interference.
- **Temperature control.** Thermistor variable-speed fan with locked rotor protection, and polarity protector maintains internal temperature with minimal noise.
- **Superior reliability.** Maximum EMI/RFI shielding in a fully enclosed container meets the most stringent regulatory and safety agency standards.
- **Advanced interface.** Remote SCSI ID switch and two SCSI connectors provide multiple options in a daisy-chained environment.
- **Safety and regulatory agency approval.** You do not need to re-certify the tape drive in the Mini Tabletop enclosure.

For more information about the Mini Tabletop Cartridge Tape Subsystem, refer to the *Mini Tabletop 8mm Cartridge Tape Subsystem Product Specification*.

## Thermal Considerations for Half-High Enclosures

Half-high tape drives contain three critical heat-generating areas that are defined by the placement of the cards in the drive and the power supply. Figure 4-4 shows the placement of the cards in an EXB-8505.

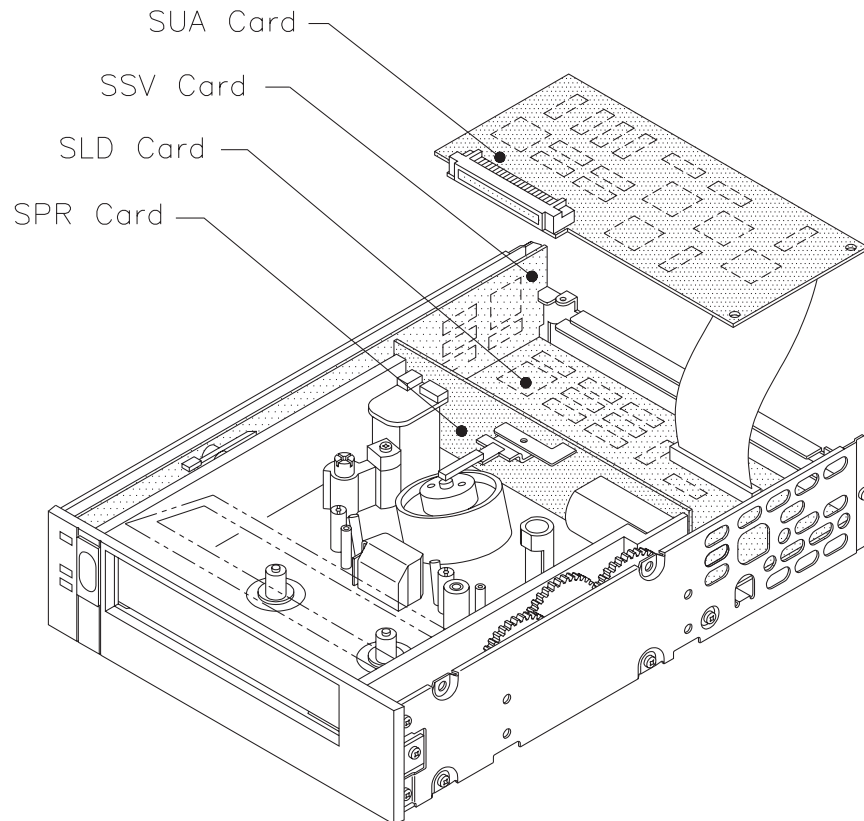

**Figure 4-4** Card placement in the EXB-8505 (shown) and EXB-8205

The area between the two horizontal cards, the SLD and the SUA (VUA for the EXB-8205) cards, contains the most heat. The highest concentration of heat is in the area surrounding the intersection of the two horizontal cards and the two vertical cards, the SSV and the SPR (VPR for the EXB-8205) cards, on the left rear side of the tape drive.

The SSV card contains several heat-generating components along the left side of the tape drive. Most of the heat-generating components are placed on card exteriors to conduct and radiate heat to the metal frame, and to allow for convection using the critically placed vents in the frame.

The placement of the power supply requires a separate cooling path because of the amount of heat it generates.



## Cooling Paths in the Mini Tabletop Enclosure

The Exabyte Mini Tabletop Cartridge Tape Subsystem enclosure provides three cooling paths. Each path flows around a heat-generating area. A thermistor-controlled fan mounted in the rear of the enclosure draws the air along the paths indicated in Figure 4-5. This design forces the maximum amount of ambient air through the highest heat-generating areas and across the exterior side of the metal frame. It also prevents most airborne contamination of the tape path by directing airflow through the critical cooling areas and reducing the amount of air through the tape path.

The enclosure separates the power supply from the tape drive and allows a separate power supply cooling path. Figure 4-5 shows the isolated area to the left of the tape deck with its own air flow path. The fan draws air through the front vertical and horizontal vents around the power supply area. With this design, you can customize the air flow to meet the heat requirements of a specific power supply. Another possible method of cooling the power supply would be to use an enclosed power supply with its own fan or a small additional fan in this separate area.

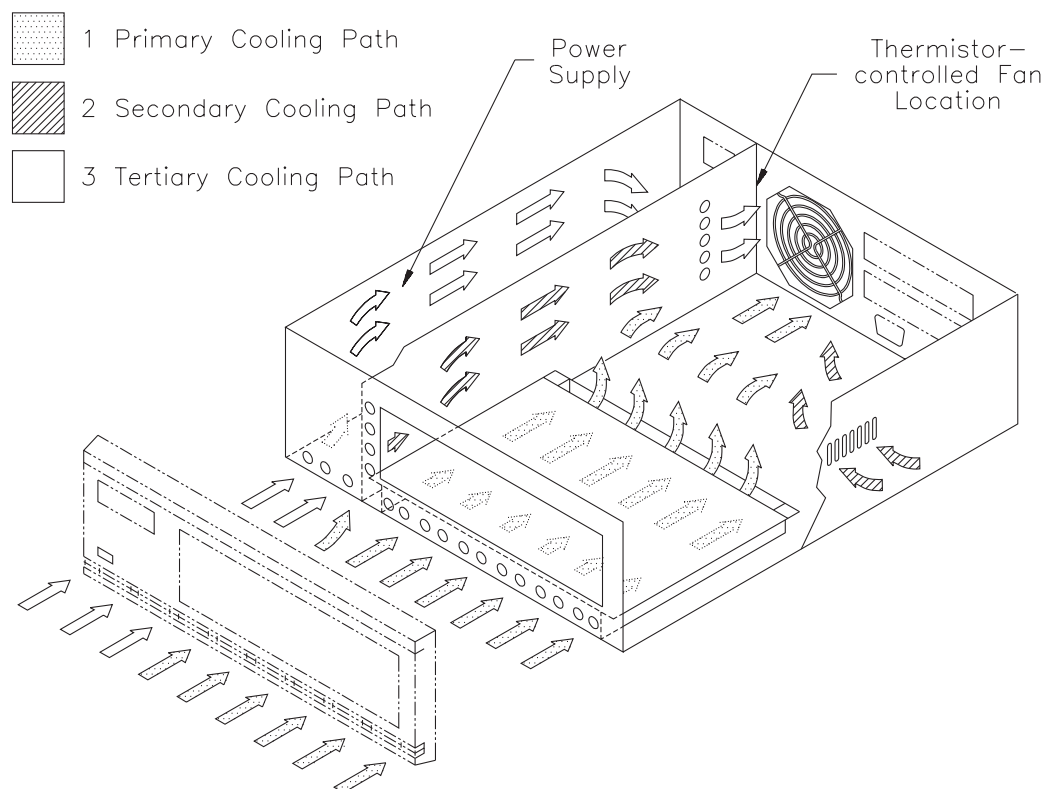

**Figure 4-5** Air flow in the Mini Tabletop Cartridge Tape Subsystem

## 4.3 SCSI Installation Requirements

---

To install the tape drive on a SCSI bus, the following equipment is required:

- SCSI cable
- SCSI cable connector
- External SCSI bus terminator (required only if the tape drive terminates the bus in a differential SCSI configuration)

### SCSI Cable

---

The SCSI cable for connecting the tape drive to a host is not supplied with the drive. You must provide a cable that complies with FCC, Canadian DOC, and VDE limits. To comply with these limits, the SCSI cable must be shielded when it is external to the tape drive's mounting enclosure.

#### General SCSI Cable Requirements

Use a 50-conductor flat cable or 25-signal twisted-pair cable. A minimum conductor size of 28 AWG is recommended to minimize noise effects and ensure proper distribution of terminator power.

Ideally, to match the cable terminators, the cable should have a characteristic impedance of 122 ohms (differential) or 132 ohms (single-ended). However, since cables with this high an impedance are not generally available, somewhat lower impedances are acceptable. A characteristic impedance of 100 ohms  $\pm$  10% is recommended for unshielded flat or twisted-pair ribbon cable. A characteristic impedance greater than 90 ohms is recommended for shielded cables.

**Note:** To minimize discontinuities and signal reflections, ensure that cables used on the same bus have the same impedances.

#### Cable Length Requirements for Differential Configurations

For differential SCSI configurations, ensure that the sum of all the SCSI cable lengths does not exceed 25.0 meters (82.02 feet). A stub length of no more than 0.2 meters (8 inches) is allowed off the mainline interconnection within any connected equipment. The stub length within the tape drive is less than 50 mm (1.97 inches).

### Cable Length Requirements for Single-Ended Configurations

For single-ended SCSI configurations, ensure that the sum of all the SCSI cable lengths does not exceed 6.0 meters (19.68 feet). A stub length of no more than 0.1 meters (4 inches) is allowed off the mainline interconnection within any connected equipment. The stub length within the tape drive is less than 50 mm (1.97 inches).

## SCSI Cable Connector

---

The tape drive's SCSI connector is located at the rear of the drive. The connector is a 50-pin male ribbon cable connector, consisting of two rows of 25 pins with adjacent pins 2.54 mm (0.1 inch) apart. To connect the tape drive to the SCSI bus, use a 50-pin female ribbon cable connector (AMP™ No. 1-746285-0 or equivalent).

## SCSI Bus Terminator

---

The SCSI bus that you attach the tape drive to must be terminated correctly to ensure proper operation. The devices that are physically located at each end of the SCSI cable must have terminators installed. All other devices on the SCSI cable must not have terminators installed.

If the tape drive will be located at the end of the SCSI bus, you must terminate the drive. The procedure you use depends on whether the drive uses a single-ended or a differential SCSI configuration.

### Termination for the Single-Ended Tape Drive

The single-ended tape drive includes three single in-line package (SIP) resistor terminators (R-packs) that can be left in place if the drive terminates the SCSI bus. Figure 4-6 shows the location of these R-packs.

#### **CAUTION**

The R-packs must be removed if the tape drive does not terminate the SCSI bus or if external SCSI bus termination is used.

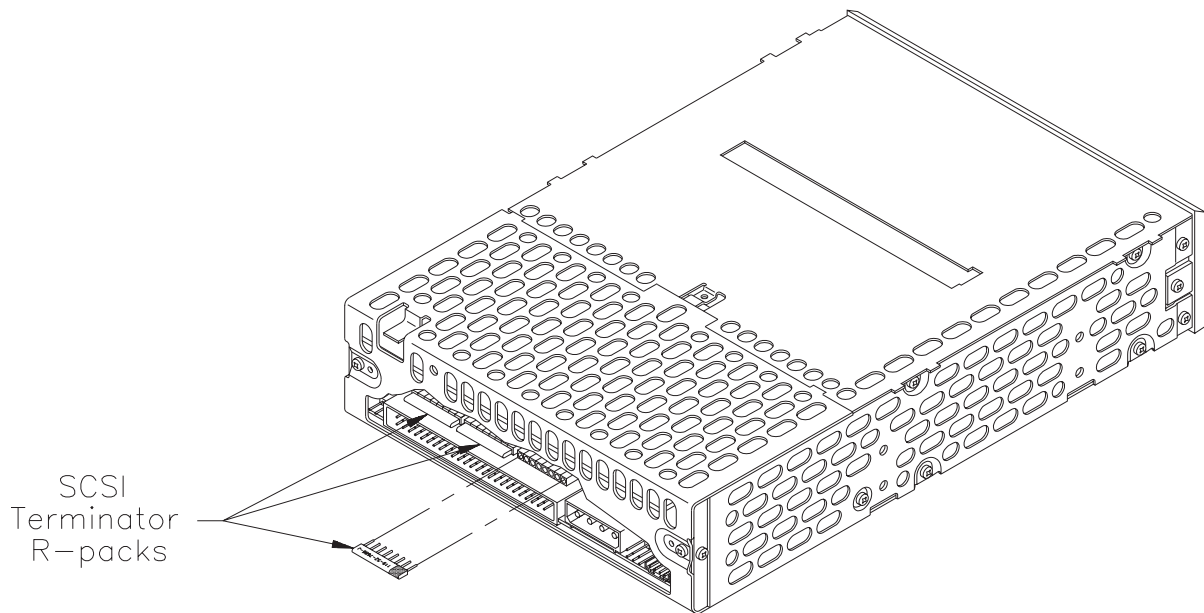

**Figure 4-6** R-packs on the back of the tape drive (single-ended)

To remove the R-packs, use a pair of flat-nose wiring pliers to grasp each R-pack in the center. Pull the R-pack straight out being careful not to squeeze the pliers too tightly.

**CAUTION**

If you replace an R-pack, be sure to use the correct type to avoid damage to the tape drive. Use an 8-pin, 6-resistor SIP terminator rated at 220/330 ohms. Exabyte recommends either of the following terminators (or equivalent):

Dale®: part number CSC 08A-05-221/331J

Beckman Industrial™: part number L08-5C221/331J

When replacing the R-pack, make sure that pin 1 of the R-pack is aligned with pin 1 of the socket and that no pins are bent. As shown in Figure 4-6, the writing on the R-pack should face upward. Pin 1 of the R-pack is marked with a colored line or dot and should line up with the right side of the socket.

### **Optional Termination for the Single-Ended Tape Drive**

If desired, you can terminate the single-ended tape drive externally by removing the R-packs from the back of the drive and installing an external terminator. Exabyte recommends a Methode Electronics, Inc. dataMate DM103-02-0 (or equivalent) single-ended external terminator.

### **Termination for the Differential Tape Drive**

The differential tape drive does not include internal terminators. If a differential drive terminates the SCSI bus, it must be terminated externally. Exabyte recommends a Methode Electronics, Inc. dataMate<sup>®</sup> DM103-01-0 (or equivalent) differential external terminator.

### **Termination for the Mini Tabletop Cartridge Tape Subsystem**

The Mini Tabletop Cartridge Tape Subsystem does not include internal SCSI bus terminators. If the Mini Tabletop Cartridge Tape Subsystem is the last device on the SCSI bus, attach an external terminator to either one of the SCSI connectors:

**Differential:** Exabyte recommends a Methode Electronics, Inc. dataMate<sup>®</sup> DM800-08-0 differential external terminator.

**Single-Ended:** Exabyte recommends a Methode Electronics, Inc. dataMate<sup>®</sup> DM800-09-0 single-ended external terminator.

## 4.4 Options for Setting the SCSI ID

You can set the SCSI ID for the half-high tape drive in either of the following ways:

- Attach jumpers (shunts) to the pins on the tape drive's SCSI ID jumper block. Jumpers are already installed on the jumper block when the drive is shipped.
- Connect a remote switch to the tape drive's SCSI ID jumper block.

Figure 4-7 shows the location of the SCSI ID jumper block and the associated pin numbers. The two methods for setting the SCSI ID are described on the following page.

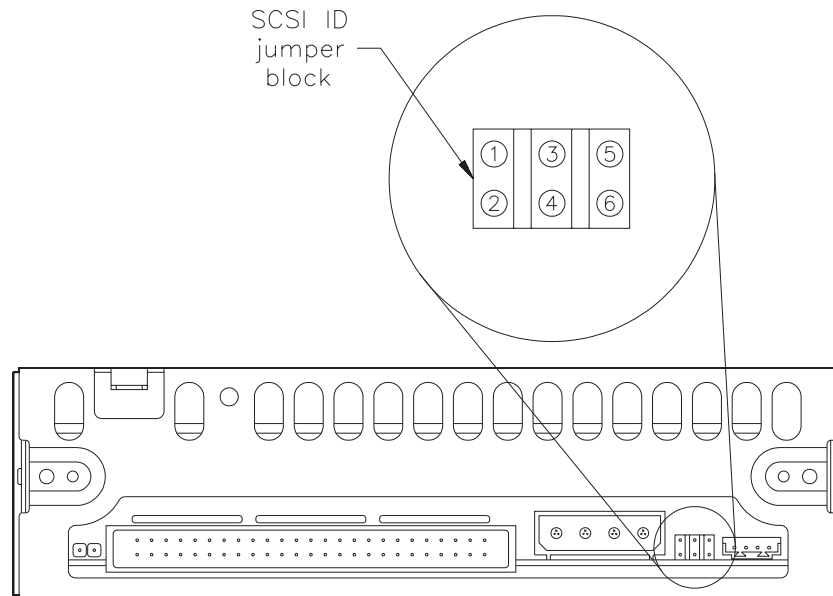

**Figure 4-7** SCSI ID jumper block at the back of the tape drive

## Setting the SCSI ID with Jumpers

To set the SCSI ID using jumpers, position the jumpers on the SCSI ID jumper block to obtain the correct address for your tape drive. Figure 4-8 shows how to position the jumpers for addresses 0 through 7.

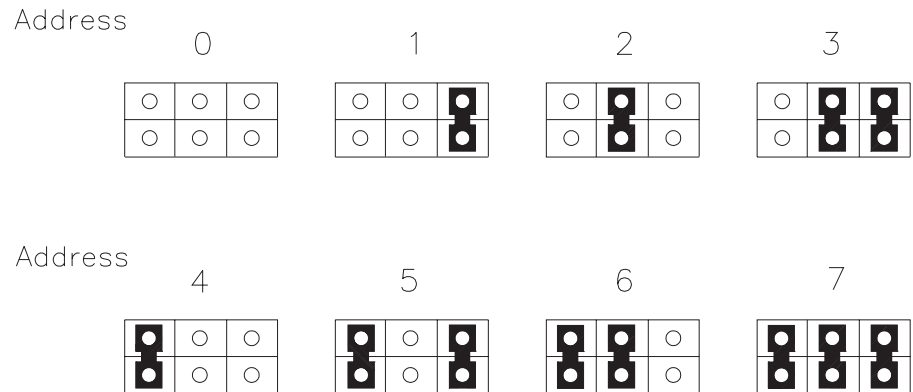

**Figure 4-8** Jumper settings for the SCSI ID

## Setting the SCSI ID with a Remote Switch

To set the SCSI ID with a remote switch (not provided), remove the jumpers from the SCSI ID jumper block and connect a remote switch assembly to the jumper block. Ensure that the remote switch is no more than 12 inches (30.5 cm) from the jumper block.

Change the settings on the remote switch to the correct address for your configuration. The switch settings should emulate the jumper positions shown in Figure 4-8.

## 4.5 Environmental Considerations

When integrated into a host system, a half-high tape drive operates best within a certain range of environmental conditions. The tape drive's operating environment has a significant effect on the life of the tapes used in the drive. This section describes the recommended limits for temperature and humidity, airflow and particulate contamination, and shock and vibration.

### Temperature and Humidity

Once a tape drive is installed in a host system and placed in its operating environment, temperature and humidity must be maintained within the limits shown in Table 4-1. For reference, storage, non-operation, and transportation limits are provided.

**Table 4-1** Environmental specifications

Specification	Tape drive in operation (with EXATAPE 8mm Data Cartridge)	Tape drive in storage <sup>a</sup> or not operating <sup>b</sup>	Tape drive being transported <sup>a</sup>
Temperature range (measured at tape path)	+5° C to + 40° C (+41° F to +104° F)	−40° C to +60° C (−40° F to +140° F)	−40° C to +60° C (−40° F to +140° F)
Temperature variation <sup>c</sup>	1° C per minute; max 10° C per hour (2° F per minute; max 18° F per hour)	1° C per minute; max 20° C per hour (2° F per minute; max 36° F per hour)	1° C per minute; max 20° C per hour (2° F per minute; max 36° F per hour)
Relative humidity <sup>c</sup>	20% to 80% Non-condensing	10% to 90% Non-condensing	10% to 90% Non-condensing
Wet bulb <sup>d</sup>	26°C (79°F) max		
Altitude	−304.8 m to +3,048 m (−1,000 ft to +10,000 ft)	−304.8 m to +3,048 m (−1,000 ft to +10,000 ft)	−304.8 m to +12,192 m (−1,000 ft to +40,000 ft)

<sup>a</sup> The tape drive has not been unpacked. Data cartridges are not packed with the drive. The tape drive's packaging is designed to protect the drive from condensation caused by extreme temperature variations. **When the tape drive is moved from a cold storage environment to a warm operating environment, it must acclimate in its packaging for at least 12 hours before opening to prevent serious condensation damage.**

<sup>b</sup> The tape drive has been unpacked but is not operating. The data cartridge is not included.

<sup>c</sup> The data cartridge's temperature and humidity must be allowed to stabilize in the specified ambient environment for 24 hours.

<sup>d</sup> The maximum wet bulb temperature limits the high temperature/high humidity operating range of the tape drive. This wet bulb temperature limitation is due to the moisture tolerance characteristics of the media.



## Air Flow and Particulate Contamination

Adequate air flow must be provided through the vents in the rear of the tape drive to prevent the tape path temperature from exceeding specified limits. However, air flow within the tape drive enclosure must not force air into the tape path. Particulate contamination resulting from air flow through the tape path can lead to data errors. The particulate counts in the drive's ambient operating environment should not exceed the limits shown in Table 4-2.

**Table 4-2** Maximum particulate counts for half-high tape drive operation

Particle Size (microns)	Number of Particles $\geq$ Particle Size per Cubic Meter	Number of Particles $\geq$ Particle Size per Cubic Foot
0.1	$8.8 \times 10^7$	$2.5 \times 10^6$
0.5	$3.5 \times 10^7$	$1.0 \times 10^6$
5.0	$2.5 \times 10^5$	$7.0 \times 10^3$

For comparison purposes, Figure 4-9 shows the particulate limits for a tape drive (CTS) plotted against the particulate contamination profile of a typical office. (Note that contamination profiles of individual areas vary.)

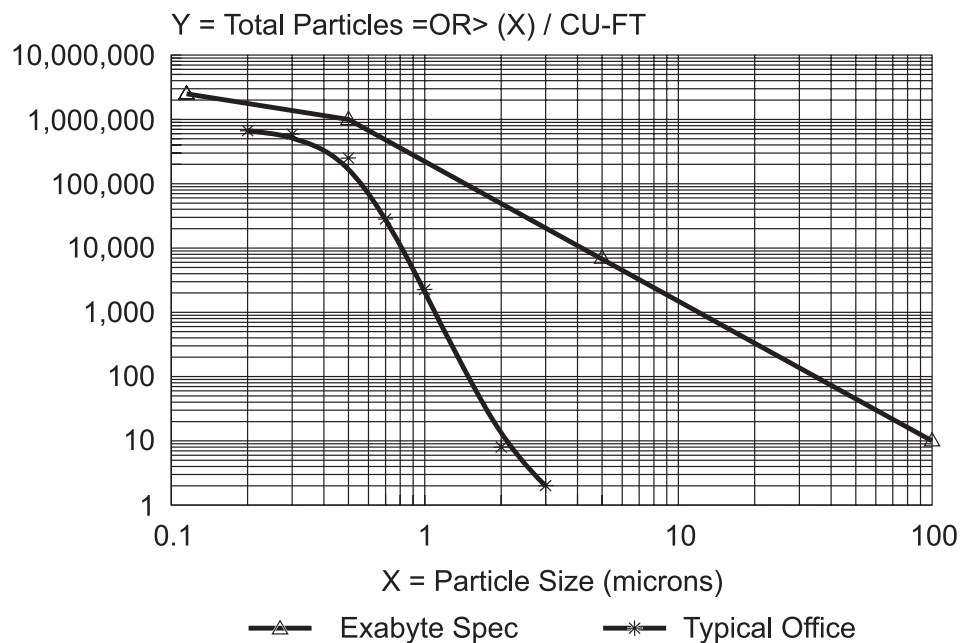

**Figure 4-9** Particulate specification for a half-high tape drive compared to a typical office

## Shock

---

Table 4-3 lists the shock specifications for the half-high tape drive. The operating shock levels indicate how much shock the drive can withstand while it is reading and writing data. The non-operating and storage shock levels indicate how much shock the drive can withstand when it is not operating. After withstanding this amount of shock, the tape drive will operate normally.

**Table 4-3** Shock specifications

Operating	Storage <sup>a</sup> or Not Operating <sup>b</sup>	Transportation <sup>a</sup>
3 g for 5 ms <sup>c</sup>	45 g at a velocity change of 192 inch/sec <sup>d</sup>	NSTA Project 1A

<sup>a</sup> The tape drive has not been unpacked.

<sup>b</sup> The tape drive has been unpacked, but no power has been applied.

<sup>c</sup> A minimum of 20 shock pulses were applied to each of the three orthogonal axes. The shock pulses were half-sine waves and were applied at a rate not exceeding one shock per second.

<sup>d</sup> A minimum of three trapezoidal shock pulses of 45 g were applied to each of the tape drive's six sides at a velocity change of 192 inches per second (equivalent height equals 48 inches).

## Vibration

Table 4-4 lists the vibration specifications for the half-high tape drive during operation, non-operation, storage, and transportation. The operating specifications listed in this table indicate the amount of vibration that the drive can withstand while reading and writing data.

**Table 4-4** Vibration specifications

<b>Random vibration<sup>a</sup> applied during operation</b>	
1 Hz	PSD = 0.000003 g <sup>2</sup> /Hz
5 Hz	PSD = 0.00002 g <sup>2</sup> /Hz
10 Hz	PSD = 0.0003 g <sup>2</sup> /Hz
200 - 400 Hz	PSD = 0.00008 g <sup>2</sup> /Hz
<b>Random vibration<sup>b</sup> applied during non-operation<sup>c</sup> and storage<sup>d</sup></b>	
1 Hz	PSD = 0.0003 g <sup>2</sup> /Hz
3 Hz	PSD = 0.00055 g <sup>2</sup> /Hz
12 Hz	PSD = 0.01 g <sup>2</sup> /Hz
100 Hz	PSD = 0.01 g <sup>2</sup> /Hz
400 Hz	PSD = 0.000003 g <sup>2</sup> /Hz
<b>Transportation<sup>d</sup></b>	
NSTA Project 1A	

<sup>a</sup> A 0.30 g RMS random vibration spectrum is applied to each of three orthogonal axes for a minimum of 20 minutes per axis.

<sup>b</sup> A 1.0 g RMS random vibration spectrum is applied to each of three orthogonal axes for a minimum of 20 minutes per axis.

<sup>c</sup> The tape drive has been unpacked, but no power has been applied.

<sup>d</sup> The tape drive has not been unpacked.

## 4.6 Power and Grounding Considerations

---

When connecting power to a half-high tape drive, you must consider the following issues:

- Power supply requirements
- Options for additional chassis grounding
- Power cable and connector requirements

In addition, before you apply power to a new tape drive for the first time, check the MLCH (machine level control history) label on the top of the drive to determine when the drive was manufactured. If the drive was manufactured more than six months earlier, Exabyte recommends that you perform a short read/write procedure after the initial power-on to ensure that the drive's internal lubrication is properly distributed. This procedure is described in *EXB-8205 and EXB-8505 Installation and Operation*.

### Power Supply

---

The half-high tape drive operates from standard +5 VDC and +12 VDC supply voltages; it does not use external AC power. Safety agency certification requires that the supplied voltages for a tape drive be from a Safety Extra-Low Voltage source (per IEC 950). Refer to the *EXB-8205 and EXB-8505 Product Specification* for detailed information about power consumption and operating current specifications.

### Additional Chassis Grounding

---

The rear panel of the half-high tape drive includes a grounding hole and ground tab, as shown in Figure 4-10. If desired, you can use either the grounding hole or ground tab to provide additional chassis grounding, as follows:

- Connect a 1/4-inch female spade connector to the ground tab.
- Connect an M3-0.5 × 6 mm self-tapping screw to the grounding hole.

**Note:** The power supply returns are connected to the chassis, so you cannot isolate logic common ground from chassis ground.

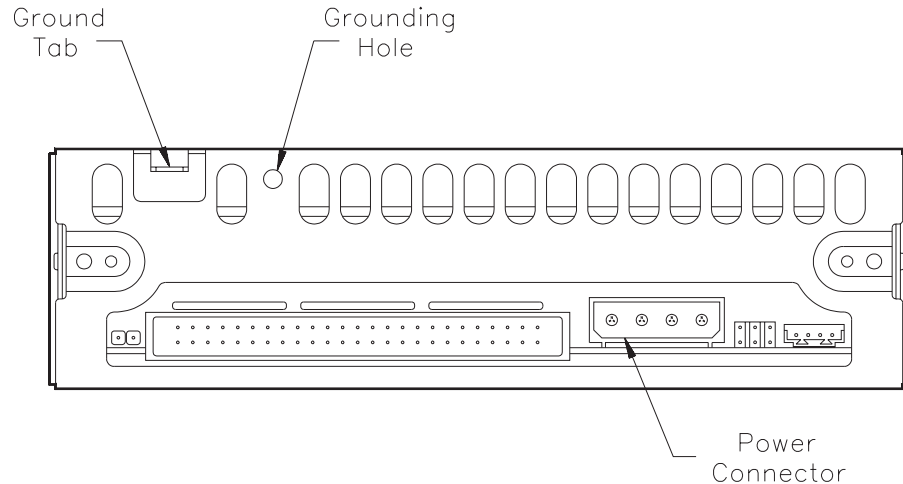

**Figure 4-10** Location of the ground tab, grounding hole, and power connector on the back of the tape drive

## Power Cable and Connector

### CAUTION

The tape drive does not provide any overvoltage or overcurrent protection. For this reason, be sure that the power is off before connecting the drive to a power supply.

The power connector used in the half-high tape drive is compatible with power connectors used for standard 5.25-inch, half-high devices. The location of the power connector is shown in Figure 4-10. To connect the drive to a power cable, use an AMP 1-480424-0 series (or equivalent) female connector.

### CAUTION

The power cable plug and the power connector are keyed so that they fit together in only one way. Before connecting the plug to the tape drive, be sure that the beveled edges of the plug are oriented in the same way as the beveled edges on the power connector. Do not force the plug into the connector or you may damage the tape drive.

## 4.7 Product Compliance Standards

---

All Exabyte half-high tape drives are certified as components that comply with the regulatory standards listed in this section. When properly installed in a shielded cabinet with shielded cables and adequate grounding of the SCSI bus and input power, the tape drive can be expected to maintain its compliance with these standards. Any required certification of the final system containing the tape drive is the responsibility of the system integrator.

**Note:** Exabyte products that contain an enclosed half-high tape drive, such as the Mini Tabletop 8mm Cartridge Tape Subsystem, can be resold with no further certification.

### Product Safety Standards

- UL 1950, 1st Edition, Information Technology Equipment including Electrical Business Equipment
- CSA-C22.2 No. 950-M89, Safety of Information Technology Equipment including Electrical Business Equipment
- EN60950/IEC950/DIN VDE 0805/05.90, Safety of Information Technology Equipment including Electrical Business Equipment

### Electromagnetic Interference (EMI)

- FCC Rules and Regulations, Part 15 - Radio Frequency Devices: Subpart B, Unintentional Radiators, Class B
- Canadian Department of Communications (DOC), Radio Interference Regulation, Digital Apparatus, Class B
- VDE0871/6.78, Class B, German Postal Regulation Vfg 243/1991 and Vfg 46/1992

## Electromagnetic Compatibility (EMC)

- IEC 801-2, Second Edition 1991-04, Electromagnetic Compatibility for Industrial-Process Measurement and Control Equipment, Part 2: Electrostatic Discharge Requirements, as follows:

The tape drive can withstand discharges of:

- Up to 10 kilovolts (kV) applied to those points that are accessible during normal use without affecting the permanent read error rate or requiring operator intervention.
- Up to 15 kV applied to those points that are accessible during normal use without sustaining permanent damage. However, at this level of discharge, operator intervention may be required to reset the tape drive.

**Note:** No errors will occur or damage be caused to the drive when a cartridge charged to up to 20 kV is inserted.

- IEC 801-3, First Edition 1984, Electromagnetic Compatibility for Industrial-Process Measurement and Control Equipment, Part 3: Radiated Electromagnetic Field Requirements, as follows:

The tape drive will continue to operate without error when subjected to electromagnetic energy of severity level 2 (3 volts/meter).

## Notes:

---



# 5

## Half-High Tape Drive Maintenance

The most important part of maximizing half-high tape drive reliability and tape life is regular cleaning of the drive. Operating a tape drive without regular cleaning can lead to increased error rates, and ultimately, drive failure.

You should begin cleaning a tape drive regularly as soon as the device is put into use. This chapter explains why cleaning is so important and provides guidelines for determining when a tape drive requires cleaning.

### CAUTION

Except for cleaning, Exabyte tape drives require no user maintenance or adjustments. All service or repairs must be performed by Exabyte or authorized service personnel.

## 5.1 What Causes a Tape Drive to Require Cleaning?

---

Tape drives are rarely operated in perfectly clean, temperature-controlled, humidity-controlled environments. Although a tape drive does not require perfect environmental conditions, its performance can be adversely affected by contaminants such as dust, grit, and smoke. The effects of contaminants are often exacerbated by wide temperature and humidity variations. (Refer to Chapter 4 for detailed information about optimizing the tape drive's operating environment for maximum performance and head and tape life.)

Another factor that can cause a tape drive to require cleaning is debris from the tape. All tapes generate some amount of debris. A new tape can contain debris created during the manufacturing process that is shed into the tape path the first few times the tape is used. Throughout its life, a tape generates small amounts of debris from its edges where the base film is exposed. An overused or improperly stored and handled tape can also generate debris due to damage such as cracking.

The main consequences of operating a tape drive without regular cleaning are poor performance and eventually, drive failure. The debris introduced from the environment and generated by the tapes can build up in the tape path and on the recording heads. This increases head wear and reduces recording reliability and tape life. Error rates typically increase, and permanent damage of the recording heads may occur.

## 5.2 Determining When to Clean the Tape Drive

---

You should clean the tape drive's heads and tape path either **once a month or after every 30 tape motion hours**, whichever occurs first. This cleaning frequency does not depend on the format in which you write and read data. However, if you are using the drive in a particularly dirty environment or if you operate it infrequently, you may want to clean the drive more often than every 30 tape motion hours.

The tape drive keeps track of tape motion hours internally. You can access this information in either of the ways described below.

### Time-to-Clean LED Indication

---

When 30 tape motion hours have elapsed, the top and bottom LEDs will flash rapidly and the middle LED will flash irregularly, depending on SCSI bus activity.

For best results, clean the tape drive as soon as possible after the LEDs begin flashing. You may want to use the LEDs in conjunction with some type of application prompt to provide additional indication that the tape drive needs cleaning.

### REQUEST SENSE Command

---

You can issue a REQUEST SENSE command and look at the setting of the CLN and CLND bits (byte 21, bits 4 and 3). If the CLN bit is set to 1, the tape drive needs to be cleaned. This bit is reset to 0 when you perform a successful cleaning cycle. The CLND bit is set to 1 when the drive has been cleaned and is reset to 0 when the next REQUEST SENSE command is received.

By issuing frequent REQUEST SENSE commands and monitoring this information, an application program can determine exactly when cleaning is required. The application can prompt the user in any number of ways when the tape drive needs to be cleaned.

## 5.3 Using an Exabyte-Approved Cleaning Cartridge

---

To clean a tape drive, use only Exabyte or Exabyte-approved 8mm cleaning cartridges. The Exabyte 8mm Cleaning Cartridge is designed specifically for use in Exabyte products and, if used according to instructions, meets the requirements of the tape drive's warranty. The Exabyte 8mm Cleaning Cartridge comes in two sizes: 3c and 12c. Used in the EXB-8205, EXB-8505, or XL tape drives, the 3c cleaning cartridge provides up to 9 cleanings. The 12c cleaning cartridge provides up to 36 cleanings.

**Note:** If you use these cleaning cartridges in an Exabyte full-high tape drive (EXB-8200, EXB-8200SX, EXB-8500, or EXB-8500c), you will get fewer cleaning passes per cartridge. These tape drives have longer tape paths than the EXB-8205, EXB-8505, and XL drives, and require more material for each cleaning.

### What About Other Cleaning Cartridges?

---

A variety of cleaning cartridges are available for use in video recorders. Most of these cleaning cartridges are far too abrasive for tape drive recording heads. The cleaning technique employed in these cartridges is equivalent to scouring away debris that has built up on surfaces over an extended period of time.

Some video cleaning cartridges are designed to be used over and over. When you reuse a cleaning cartridge, debris is often just recirculated through the tape drive. Furthermore, some video cleaning cartridges may use liquids that adversely affect the tape mechanism, while others can cause a crystalline structure to form on the heads and destroy them.

#### CAUTION

Do not use a cleaning method other than the Exabyte 8mm Cleaning Cartridge or an Exabyte-approved cleaning cartridge or you will void the warranty for the tape drive and you may damage the drive.

## Procedure for Cleaning a Tape Drive

---

### CAUTION

To prevent contamination of the tape drive and damage to the heads, **never rewind and reuse the cleaning cartridge**. Reusing the material in the cleaning cartridge will redistribute contaminants previously removed from the tape path.

The cleaning procedure for a tape drive consists of the following steps:

- 1** Apply power to the tape drive. When the power-on self-test is complete, press the unload button and remove any data cartridge from the drive.
- 2** Insert the cleaning cartridge into the tape drive.

The tape drive automatically recognizes the presence of a cleaning cartridge and performs a cleaning cycle, which lasts from 2 to 3 minutes. When the cleaning cycle is complete, the cleaning cartridge is automatically unloaded and ejected.

---

**Important** If there are no more cleaning cycles remaining for the cleaning cartridge, the drive ejects it without performing a cleaning cycle. The top and bottom LEDs remain lit. Discard the cleaning cartridge when no more cleaning cycles remain.

---

- 3** To confirm that a cleaning was done, check the LEDs on the front panel. If the cleaning cycle was successful, the top and bottom LEDs will be off. If the cleaning cycle was not performed, the LEDs will continue to flash.

You can also issue a REQUEST SENSE command and check the setting of the CLND bit. If set to 1, the CLND bit indicates that a successful cleaning cycle was performed. If the CLND bit is 0, the cleaning cycle was not performed.

- 4** If the cleaning cycle was successful, you may want to keep a record of the date the cleaning was performed. Store the cleaning cartridge for future use if it still has cycles remaining. Or, discard it if no more cleaning cycles remain.

**Notes:**

---

# 6

## Software Integration Issues

This chapter addresses some of the software issues you may encounter when integrating a half-high tape drive into a system. First, tape drive timing issues are discussed. Then, guidelines for converting an existing driver for a full-high tape drive to support a half-high tape drive are provided. Finally, issues you must consider when adding XL support to a driver are addressed.

## 6.1 Tape Drive Timing Considerations

The mechanics of tape handling in a tape drive, combined with data buffering, create a number of timing considerations that must be accounted for in an application. Table 6-1 is an overview of some of the situations you must account for in your driver program.

**Table 6-1** Timing considerations for tape drive applications

Event	Description
<b>Power-on self-test (POST)</b>	<p>A power-on self-test (POST) occurs each time you apply power to the tape drive. During POST, the drive performs its internal diagnostics.</p> <p>The half-high tape drive completes POST in approximately 30 seconds.</p>
<b>Initialization</b>	<p>Following a SCSI bus reset or Bus Device Reset message, the tape drive must initialize before it can respond to any SCSI bus signals.</p> <p>After initialization, the half-high tape drive responds on the SCSI bus within 250 milliseconds.</p>
<b>Data cartridge load</b>	<p>Load time is the time required for the tape drive to position the tape to LBOT (logical beginning of tape) after the cartridge is inserted. During the load operation, the drive spaces forward from PBOT (physical beginning of tape) and determines the format of data on the tape (if previously written), the adaptive servo parameters (which enable the drive to read tapes written by other 8mm tape drives), and the length of the tape.</p> <p>The half-high tape drive loads a data cartridge in approximately 40 seconds.</p>
<b>Write access</b>	<p>Write access time starts when the tape drive receives the last byte of the WRITE command (when the initiator de-asserts ACK) and ends when the drive asserts REQ to request that the initiator transfer the first data byte across the SCSI bus.</p> <p>The write access time for the half-high tape drive is 1.7 msec in start/stop mode and 3.1 msec in streaming mode. Note that during the 3.1 msec, the drive does not remain connected to the SCSI bus.</p>
<b>Read access</b>	<p>Read access time starts when the tape drive receives the last byte of the READ command (when the initiator de-asserts ACK) and ends when the drive asserts REQ to indicate that it is ready to transfer the first data byte across the SCSI bus to the initiator.</p> <p>When data is present in the buffer, the read access time for the half-high tape drive is 1.8 msec in start/stop mode and 3.1 msec in streaming mode. When no data is present in the buffer (first read operation after the tape is loaded), the read access time is approximately 8 seconds.</p>



Event	Description
<b>Reposition</b>	<p>Reposition time starts when the initiator issues a command that stops the tape drive's motion control system and ends when the tape is repositioned, at normal speed, so that the next byte of data can be transferred. Reposition time is independent of any interface delays.</p> <p>The reposition time for the half-high tape drive is 1.2 to 1.5 seconds.</p>
<b>Retensioning of tape after tension has been released</b>	<p>The tape drive can perform tape motion commands only when the tape is tensioned. The drive releases tape tension under the following conditions:</p> <ul style="list-style-type: none"> <li>When the tape is at LBOT and the drive has not received a tape motion command within 5 seconds.</li> <li>When the tape is not at LBOT and the drive has not received a tape motion command within 15 seconds.</li> </ul> <p>The retension time for the half-high tape drive is approximately 1.5 seconds.</p>
<b>Restarting of drum motion after motion has been suspended</b>	<p>The tape drive stops drum motion after releasing tape tension if it does not receive a tape motion command within 60 seconds. The drive cannot perform a tape motion command until drum motion has resumed.</p> <p>The half-high tape drive restarts drum motion in approximately 7 seconds.</p>
<b>Rewind data cartridge</b>	<p>Rewind time starts when the initiator issues a REWIND command and ends when the tape drive returns a Command Complete message (for a non-immediate rewind). The rewind time is based on the following assumptions:</p> <ul style="list-style-type: none"> <li>The tape is positioned at LEOT when the REWIND command is issued.</li> <li>The drum is still rotating.</li> <li>Tape tension has not been released.</li> </ul> <p>The rewind time for a 112m cartridge is approximately 170 seconds. For the EXB-8205XL and EXB-8505XL only, the rewind time for a 160m XL cartridge is approximately 240 seconds.</p>
<b>Data cartridge unload</b>	<p>The unload operation involves rewinding the tape from LBOT to PBOT, removing the tape from the tape path, and ejecting the cartridge. Additional time must be added under the following circumstances:</p> <ul style="list-style-type: none"> <li>The tape is not at LBOT (add rewind time).</li> <li>There is unwritten data in the buffer (add time to write the data to tape).</li> </ul> <p>The unload time for the half-high tape drive is approximately 19 seconds.</p>
<b>Buffer latency delay</b>	<p>This is the time required to "flush" the buffer before the tape drive can execute a tape motion command. The MODE SELECT Motion Threshold and Reconnect Threshold affect this timing. To avoid the buffer latency delay, you can issue a WRITE FILEMARKS command with a count of 0 after every write operation to flush the buffer.</p>

## 6.2 Converting a Full-High Driver to a Half-High Driver

If you have been supporting any of the Exabyte full-high tape drives (EXB-8200, EXB-8200SX, EXB-8500, or EXB-8500c) and want to convert an existing driver to support one of the half-high tape drives, you need to consider the issues listed in Table 6-2.

If you are converting a full-high driver to support one of the XL tape drives (EXB-8205XL or EXB-8505XL), accommodate the issues listed in the table first. Then, refer to Section 6.3 on page 6-6 for information about adding support for XL.

**Note:** If you wish to use an existing full-high driver for a half-high tape drive without modifications, you can obtain EEPROM images from Exabyte that enable half-high drives to emulate full-high drives. See page 2-7 for information about ordering EEPROM images.

**Table 6-2** Converting a full-high driver to a half-high driver

You need to consider these issues for a half-high driver...	If you are converting from a driver that supports the...			
	EXB-8200	EXB-8200SX	EXB-8500	EXB-8500c
Implementing SCSI-2 commands	✓	✓		
Checking for illegal or new density code values	✓	✓	✓	✓*
Changing the product identification value in INQUIRY data	✓	✓	✓	✓
Changing from synchronous data transfer only to either synchronous or asynchronous, as desired	✓	✓		
Implementing data compression support	✓	✓	✓	
Converting SHOW BLOCK and FIND BLOCK commands to READ POSITION and LOCATE commands		✓		
Implementing support for space-to-EOD, as desired	✓	✓		

\* If you are creating an EXB-8205 or EXB-8205XL driver, you need to consider this issue. If you are creating an EXB-8505 or EXB-8505XL driver, no change is needed.

You need to consider these issues for a half-high driver...	If you are converting from a driver that supports the...			
	EXB-8200	EXB-8200SX	EXB-8500	EXB-8500c
Implementing support for setmarks, as desired (EXB-8505 and EXB-8505XL only)	✓	✓	✓	
Implementing partitions, as desired (EXB-8505 and EXB-8505XL only)	✓	✓	✓	
Accommodating different filemark sizes (depending on data format)	✓	✓	✓	✓*
Accommodating different EEPROM options	✓	✓	✓	✓
Accommodating time-to-clean LED	✓	✓	✓	✓
Accommodating CLN and CLND bits in REQUEST SENSE	✓	✓		
Accommodating different completion times for the following activities (refer to page 6-2 for actual times): Power-on self-test (POST) Data cartridge load Write access Read access Data cartridge rewind Data cartridge unload	✓	✓	✓	✓
Accommodating different completion times for the following activities (refer to page 6-2 for actual times): Initialization Reposition of tape Restart of drum motion	✓	✓		

\* If you are creating an EXB-8205 or EXB-8205XL driver, you need to consider this issue. If you are creating an EXB-8505 or EXB-8505XL driver, no change is needed.

## 6.3 Adding XL Support to a Half-High Driver

If you already have a driver for a half-high tape drive and would like to add support for the XL version, there are just a few issues you need to consider. These issues, described in Table 6-3, primarily involve accommodating the longer tape length (160m) supported by the XL tape drives.

**Table 6-3** Adding XL support to a half-high driver

Issue	Description
<b>New value for Medium Type in the MODE SENSE command</b>	In the MODE SENSE Parameter List Header, a new value has been added for Medium Type (byte 01) to represent the 160m XL tape. This value is 86h. Your driver must accept this new value from the tape drive.
<b>Higher value for Number of Blocks in the MODE SENSE command</b>	In the MODE SENSE Block Descriptor, the value returned by the tape drive for Number of Blocks (bytes 01 through 03) will be higher when a 160m XL tape is loaded than when the other supported tape lengths are loaded. The value for the 160m XL tape is 68E68Bh.
<b>Higher values for Remaining Tape in the REQUEST SENSE data</b>	In the extended sense bytes, the values returned by the tape drive for Remaining Tape (bytes 23 through 25) will be higher when a 160m XL tape is loaded than when the other supported tape lengths are loaded. If your driver monitors this value to provide “gas gauge” indicators to the user (such as “Tape half full”), you will need to modify the values your driver checks for accordingly.
<b>Rewind timeout</b>	If your driver has a maximum timeout for rewinding the tape, you may need to adjust this value to account for the longer rewind time required for the 160m XL tape (see page 6-3).

# 7

## SCSI Integration

If you create a driver program for a half-high tape drive, you must understand how the tape drive implements the Small Computer System Interface (SCSI). This chapter provides an overview of SCSI communication, including the SCSI commands, statuses, and messages supported by the drive. It also discusses the following topics:

- Tape drive support for disconnecting from the SCSI bus
- The availability of enhanced SCSI bus performance and the resulting driver integration issues
- Options for customizing the tape drive's SCSI configuration

## 7.1 Overview of SCSI Communications

Table 7-1 shows the commands, status information, and messages that the half-high tape drives support during SCSI bus phases.

**Table 7-1** Overview of supported SCSI commands, status information, and messages

SCSI Bus Phase	Explanation																										
<b>Bus Free</b>	BSY and SEL are false. The SCSI bus is idle and available for arbitration.																										
<b>Arbitration</b>	BSY and SCSI ID assertion (highest ID wins).																										
<b>Selection</b>	Winning ID asserts SEL. The initiator releases I/O and BSY. The tape drive sets BSY. The initiator releases SEL and asserts ATN.																										
<b>Message Out</b>	<p>The initiator sends the <b>Identify</b> message and indicates whether disconnects are permitted. Other messages supported during the Message Out phase, but in a different bus sequence include:</p> <p><b>Extended Message (Synchronous Data Transfer Request)</b>  <b>Initiator Detected Error</b>  <b>Abort</b>  <b>Message Reject</b>  <b>No Operation</b>  <b>Message Parity Error</b>  <b>Bus Device Reset</b></p>																										
<b>Command</b>	<p>The tape drive switches to Command Phase. The Initiator sends the Command CDB. Commands supported by the tape drive include (alphabetical order):</p> <table> <tbody> <tr> <td><b>ERASE</b></td> <td><b>RECEIVE DIAGNOSTIC RESULTS</b></td> </tr> <tr> <td><b>INQUIRY</b></td> <td><b>RELEASE UNIT</b></td> </tr> <tr> <td><b>LOAD/UNLOAD</b></td> <td><b>REQUEST SENSE</b></td> </tr> <tr> <td><b>LOCATE</b></td> <td><b>RESERVE UNIT</b></td> </tr> <tr> <td><b>LOG SELECT</b></td> <td><b>REWIND</b></td> </tr> <tr> <td><b>LOG SENSE</b></td> <td><b>SEND DIAGNOSTIC SPACE</b></td> </tr> <tr> <td><b>MODE SELECT</b></td> <td><b>TEST UNIT READY</b></td> </tr> <tr> <td><b>MODE SENSE</b></td> <td><b>VERIFY</b></td> </tr> <tr> <td><b>PREVENT/ALLOW MEDIUM REMOVAL</b></td> <td><b>WRITE</b></td> </tr> <tr> <td><b>READ</b></td> <td><b>WRITE BUFFER</b></td> </tr> <tr> <td><b>READ BLOCK LIMITS</b></td> <td><b>WRITE FILEMARKS</b></td> </tr> <tr> <td><b>READ BUFFER</b></td> <td></td> </tr> <tr> <td><b>READ POSITION</b></td> <td></td> </tr> </tbody> </table>	<b>ERASE</b>	<b>RECEIVE DIAGNOSTIC RESULTS</b>	<b>INQUIRY</b>	<b>RELEASE UNIT</b>	<b>LOAD/UNLOAD</b>	<b>REQUEST SENSE</b>	<b>LOCATE</b>	<b>RESERVE UNIT</b>	<b>LOG SELECT</b>	<b>REWIND</b>	<b>LOG SENSE</b>	<b>SEND DIAGNOSTIC SPACE</b>	<b>MODE SELECT</b>	<b>TEST UNIT READY</b>	<b>MODE SENSE</b>	<b>VERIFY</b>	<b>PREVENT/ALLOW MEDIUM REMOVAL</b>	<b>WRITE</b>	<b>READ</b>	<b>WRITE BUFFER</b>	<b>READ BLOCK LIMITS</b>	<b>WRITE FILEMARKS</b>	<b>READ BUFFER</b>		<b>READ POSITION</b>	
<b>ERASE</b>	<b>RECEIVE DIAGNOSTIC RESULTS</b>																										
<b>INQUIRY</b>	<b>RELEASE UNIT</b>																										
<b>LOAD/UNLOAD</b>	<b>REQUEST SENSE</b>																										
<b>LOCATE</b>	<b>RESERVE UNIT</b>																										
<b>LOG SELECT</b>	<b>REWIND</b>																										
<b>LOG SENSE</b>	<b>SEND DIAGNOSTIC SPACE</b>																										
<b>MODE SELECT</b>	<b>TEST UNIT READY</b>																										
<b>MODE SENSE</b>	<b>VERIFY</b>																										
<b>PREVENT/ALLOW MEDIUM REMOVAL</b>	<b>WRITE</b>																										
<b>READ</b>	<b>WRITE BUFFER</b>																										
<b>READ BLOCK LIMITS</b>	<b>WRITE FILEMARKS</b>																										
<b>READ BUFFER</b>																											
<b>READ POSITION</b>																											

SCSI Bus Phase	Explanation				
<b>Data In/Out</b>	The tape drive drives the bus to one of the Data phases and sends or receives data.				
<b>Status</b>	<p>The tape drive returns one byte of status information, as follows:</p> <table border="0" data-bbox="623 415 1338 485"> <tr> <td data-bbox="623 415 834 447"><b>Good</b></td> <td data-bbox="1073 415 1138 447"><b>Busy</b></td> </tr> <tr> <td data-bbox="623 447 834 478"><b>Check Condition</b></td> <td data-bbox="1073 447 1338 478"><b>Reservation Conflict</b></td> </tr> </table>	<b>Good</b>	<b>Busy</b>	<b>Check Condition</b>	<b>Reservation Conflict</b>
<b>Good</b>	<b>Busy</b>				
<b>Check Condition</b>	<b>Reservation Conflict</b>				
<b>Message In</b>	<p>The tape drive returns one byte of message information, as follows:</p> <p><b>Command Complete</b></p> <p>Other messages supported during the Message In phase, but in a different sequence of bus activity, include:</p> <p><b>Extended Message (Synchronous Data Transfer Request)</b>  <b>Save Data Pointers</b>  <b>Restore Pointers</b>  <b>Disconnect</b>  <b>Message Reject</b>  <b>Identify</b></p>				

## SCSI Commands

The half-high tape drives support the SCSI commands shown in Table 7-2.

**Table 7-2** Supported SCSI commands

Command	Operation code (hex)	What the tape drive does in response to this command
<b>ERASE</b>	19h	Erases the tape starting from the current legal position to the physical end of tape (PEOT). Rewinds the tape when finished.
<b>INQUIRY</b>	12h	Provides the initiator with information about the drive's device parameters, including product and vendor identification.
<b>LOAD/ UNLOAD</b>	1Bh	Loads or unloads a data cartridge. When loading a cartridge, the drive places the tape in the tape path and positions it at the logical beginning of tape (LBOT) or the logical beginning of the default partition. When unloading a data cartridge, the drive writes any buffered information to the tape, rewinds the tape to the physical beginning of the tape (PBOT), removes the tape from the tape path, and ejects the data cartridge (unless ejection has been prevented by a PREVENT/ALLOW MEDIUM REMOVAL command).
<b>LOCATE</b>	2Bh	Positions the tape at a specified logical position. (Typically, this position is determined by data that was obtained through a previous READ POSITION command.)
<b>LOG SELECT</b>	4Ch	Manages a set of internal counters regarding read and write error recovery operations. The initiator can set threshold and cumulative values for the counters or reset the counters.
<b>LOG SENSE</b>	4Dh	Returns the values of the counters managed by the LOG SELECT command. These values provide the initiator with statistical information about the read and write error recovery operations that the tape drive has performed.
<b>MODE SELECT</b>	15h	Changes the drive's internal medium, logical unit, or device parameters to values specified by the initiator.
<b>MODE SENSE</b>	1Ah	Provides the initiator with information about the drive's internal medium, logical unit, and device parameters.



Command	Operation code (hex)	What the tape drive does in response to this command
<b>PREVENT/ALLOW MEDIUM REMOVAL</b>	1Eh	Prevents or allows the removal of the data cartridge from the tape drive. When the PREVENT MEDIUM REMOVAL command is in effect, the drive's unload button is disabled.
<b>READ</b>	08h	Transfers data from the tape to the initiator.
<b>READ BLOCK LIMITS</b>	05h	Provides the initiator with information about the maximum and minimum logical block lengths that the tape drive can support for read and write operations in the current operating mode.
<b>READ BUFFER</b>	3Ch	Copies the tape drive's microcode to the initiator. (This command is used in conjunction with the WRITE BUFFER command to copy one drive's microcode to another drive.)
<b>READ POSITION</b>	34h	Reports the current logical position of the tape to the initiator. This allows the initiator to store the position for later use in locating data with a LOCATE command.
<b>RECEIVE DIAGNOSTIC RESULTS</b>	1Ch	Reports the results of diagnostic tests or traces of SCSI and servo command activity to the initiator.
<b>RELEASE UNIT</b>	17h	Releases the tape drive from exclusive use by the initiator that had previously reserved it with a RESERVE UNIT command.
<b>REQUEST SENSE</b>	03h	Provides the initiator with sense information describing a condition that just occurred.
<b>RESERVE UNIT</b>	16h	Reserves the tape drive for exclusive use by the initiator that issued the command.
<b>REWIND</b>	01h	Rewinds the tape to the logical beginning of the tape (LBOT) or the logical beginning of the current partition.
<b>SEND DIAGNOSTIC</b>	1Dh	Performs diagnostic functions specified by the initiator. (For the initiator to receive the results of the tests, this command must be followed by a RECEIVE DIAGNOSTIC RESULTS command.)
<b>SPACE</b>	11h	Searches forward or backward on the tape a specified number of logical blocks, filemarks, or setmarks (8500c format only). For tapes written in 8200c, 8500, or 8500c format, the tape drive can also space to the end of data (EOD).

Command	Operation code (hex)	What the tape drive does in response to this command
<b>TEST UNIT READY</b>	00h	Indicates whether the tape drive is ready to accept a medium access command (such as READ or WRITE) from the initiator.
<b>VERIFY</b>	13h	Verifies the type or length of one or more logical blocks of data on the tape.
<b>WRITE</b>	0Ah	Accepts data from the initiator to be written to the tape.
<b>WRITE BUFFER</b>	3Bh	Transfers new microcode from the initiator into the tape drive's control memory. (This command is used in conjunction with the READ BUFFER command to copy one drive's microcode to another drive.)
<b>WRITE FILEMARKS</b>	10h	Writes a specified type and number of filemarks or setmarks (8500c format only) to the tape.

## SCSI Command Status

After every command operation performed, the tape drive sends one status byte to the initiator to indicate whether the command was performed successfully or an abnormal condition occurred. Table 7-3 describes the statuses supported by the tape drive.

**Table 7-3** Supported SCSI command statuses

Status	Hex value	Meaning	Recommended action
<b>Good</b>	00h	Indicates that the tape drive successfully completed the command.	No additional action is required.
<b>Check Condition</b>	02h	Indicates an error, exception, or abnormal condition occurred.	Issue a REQUEST SENSE command.
<b>Busy</b>	08h	Indicates that the tape drive is busy and cannot complete the command at this time.	Reissue the command.
<b>Reservation Conflict</b>	18h	Indicates that the tape drive is reserved for the exclusive use of another initiator.	Have the reserving initiator issue a RELEASE UNIT command or reset the bus.

## SCSI Messages

The SCSI message system assists in the management of the physical path between the initiator and the tape drive. This includes management of error detection, data transfer retries, and the data path. Messages allow communication between the initiator and the tape drive during an operation. Table 7-4 shows the messages that the half-high tape drives support.

**Table 7-4** Supported SCSI messages

Message	Hex Value	Direction*		Description
		In	Out	
<b>Command Complete</b>	00h	✓		The tape drive sends this message to indicate that it completed the command operation.
<b>Extended Message (Synchronous Data Transfer Request)</b>	01h	✓	✓	The tape drive and initiator use this message to negotiate synchronous data transfer agreements. By default, the tape drive does not originate synchronous data transfer requests but returns this message in response to an initiator's request. However, the tape drive can be configured to originate synchronous data transfer requests through an EEPROM option (see Section 7.4).
<b>Save Data Pointers</b>	02h	✓		The tape drive may send this message before disconnecting from the bus to request that the initiator save the active data pointers.
<b>Restore Pointers</b>	03h	✓		The tape drive sends this message to request the initiator to restore the most recently saved command, data, and status pointers to the active state.
<b>Disconnect</b>	04h	✓		The tape drive sends this message to indicate that the physical path will be broken. The drive will reconnect later to complete the operation.
<b>Initiator Detected Error</b>	05h		✓	The initiator sends this message to indicate that it has detected an error. The tape drive responds with Check Condition status with the sense key set to Aborted Command.

Message	Hex Value	Direction*		Description
		In	Out	
<b>Abort</b>	06h		✓	The initiator sends this message to clear the present operation. The tape drive responds by flushing the buffer and releasing the bus to the Bus Free phase.
<b>Message Reject</b>	07h	✓	✓	Either the tape drive or the initiator may send this message to indicate that the last message received was inappropriate or not implemented.
<b>No Operation</b>	08h		✓	The initiator sends this message when the tape drive expects the Message Out phase to occur, but no other message is appropriate. The drive resumes its operation without interruption after receiving a No Operation message.
<b>Message Parity Error</b>	09h		✓	The initiator sends this message when the previous message it received had a parity error. The tape drive responds by resending the last message.
<b>Bus Device Reset</b>	0Ch		✓	The initiator sends this message to reset a specific device on the bus. The tape drive responds by aborting the current operation, releasing the bus, and performing a reset. All data in the buffer is lost as a result of the reset.
<b>Identify</b>	80h or C0h	✓	✓	The tape drive or the initiator sends this message to establish the physical path. The Identify message indicates whether the sender supports the disconnect privilege.

\* In = the message is sent from the tape drive to the initiator.  
Out = the message is sent from the initiator to the tape drive.

## 7.2 Disconnecting from the SCSI Bus

The disconnect privilege allows other devices to use the bus while the tape drive performs an operation such as reading data from tape. Table 7-5 gives an example of how the tape drive supports the disconnect privilege during a read operation.

**Table 7-5** Example of how the drive supports disconnect during a read

Bus Phase	This action occurs...
Bus Free	Before any activity, the bus is free.
Arbitration	The initiator takes control of the bus.
Selection	The initiator selects the tape drive.
Message Out	The initiator sends the Identify message and indicates that disconnects are permitted.
Command	The tape drive switches to the Command Phase. The Initiator sends the command CDB (for example, a READ command).
Message In	The tape drive sends the Disconnect message and disconnects from the bus. The drive sets its data buffer up for a read operation.
Bus Free	The bus goes free while the drive performs the read operation.
Arbitration	The tape drive takes control of the bus.
Selection	The tape drive reselects the initiator.
Message In	The tape drive sends the Identify message to the initiator.
Data In	The tape drive transfers the data it read to the initiator.
Message In	The tape drive sends Save Data Pointers to cause the initiator to save the address of the data it just transferred. The drive then sends the Disconnect message and disconnects from the bus.
Bus Free	The bus goes free while the tape drive is disconnected.
Arbitration	The tape drive takes control of the bus.
Selection	The tape drive reselects the initiator.
Message In	The tape drive sends the Identify message to the initiator.
Status	The tape drive returns the status of the read operation.
Message In	The tape drive returns the Command Complete message and disconnects.
Bus Free	The bus goes free.

## 7.3 Optional Enhanced SCSI Bus Performance

---

Exabyte has implemented a new level of microcode for all 8mm tape drives that features *optional* enhanced SCSI bus performance. The options, described below, optimize communication between the host and tape drive and reduce SCSI-bus use by the drive. To obtain this enhanced SCSI bus performance, you must request specific settings for three EEPROM options (described below) when you order the tape drive from Exabyte. See Section 2.4 for information about requesting EEPROM options.

The enhanced SCSI bus performance includes:

- **Reduced SCSI command overhead.** By using commands that are part of its SCSI chip, the tape drive can reduce transaction times for selection and reselection, identification, reception of the command descriptor block (CDB), and data transfers.
- **Enhanced disconnect/reconnect operations.** The tape drive can disconnect from the SCSI bus while processing all SCSI commands (when allowed). Normally, the tape drive remains active on the bus while performing initial command processing and during all information commands.

Table 7-6 describes the three EEPROM options associated with this enhanced SCSI bus performance. Note that the default settings for these options reflect the normal SCSI bus performance; you must request the non-default setting for all three options to achieve the enhanced SCSI bus performance.

**Table 7-6** EEPROM options for enhanced SCSI bus performance

EEPROM option	Description	Possible values (default, non-enhanced SCSI setting shown in bold)
<b>Disconnect after CDB</b>	Controls whether the tape drive disconnects after receiving the CDB for any SCSI command.	<p><b>DISABLE</b> – The tape drive does not disconnect after receiving the CDB of an information command (except <b>MODE SELECT format partition</b>), but does disconnect after receiving a tape motion command if the command is legal.</p> <p>ENABLE (enhanced setting) – The tape drive disconnects after receiving the CDB.</p>
<b>Save pointers in Data phase</b>	Controls whether the tape drive sends a Save Data Pointers message when it is ready to disconnect after <i>all</i> data has been transferred during a Data phase.	<p><b>SP END</b> – Send the Save Data Pointers message after all data has been transferred in the Data phase.</p> <p>NO SP (enhanced setting) – Do not send the Save Data Pointers message after all data has been transferred in the Data phase.</p>
<b>Status/Command Complete</b>	Controls whether the tape drive drops the BSY line quickly (about 5 $\mu$ sec after the Command Complete message) or whether it waits longer to drop the BSY line to accommodate drivers that require the BSY line to be enabled for a longer period of time.	<p><b>NORMAL</b> – The tape drive manually reconnects, sends status, and sends the Command Complete message to the initiator. This slows the entire transaction time before the tape drive drops the BSY line to about 600 <math>\mu</math>sec.</p> <p>FAST (enhanced setting) – The tape drive sends status and the Command Complete message to the initiator using an integrated SCSI chip command. This reduces the time required for the tape drive to drop the BSY line to about 5 <math>\mu</math>sec.</p>

## Integration Issues for Enhanced SCSI Performance

---

If you choose to implement the enhanced SCSI bus performance, be aware of the following issues when creating new drivers or adapting pre-existing drivers:

- **On-bus time requirements.** Some pre-existing drivers may require longer on-bus times than are used with the enhanced SCSI bus performance.
- **Changes in message handling.** With the enhanced SCSI performance, initiators can process all standard messages at any time. Without the enhanced SCSI performance, full message processing is allowed only before the Data or Status phases.
- **Disconnects without Save Data Pointers.** With the enhanced SCSI performance, the tape drive does not issue a Save Data Pointers message before disconnecting after completing a data transfer. Without the enhanced SCSI performance, the tape drive sends a Save Data Pointers message when disconnecting even after completing a data transfer.
- **Disconnects on information commands.** With the enhanced SCSI performance, the tape drive disconnects after receiving the CDB of all commands, including information commands. Without the enhanced SCSI performance, the tape drive disconnects only after receiving tape motion commands.
- **MODE SELECT data transfers.** With the enhanced SCSI performance, the tape drive accepts all MODE SELECT data before checking for illegal values. Without the enhanced SCSI performance, the tape drive interrupts data transfer immediately after receiving an illegal value.
- **Front panel LED SCSI activity indications.** With the enhanced SCSI performance, the SCSI-status LED is turned on before reselection rather than after, so the LED may be lit even though the tape drive is inactive on the bus (for example, while attempting to reselect). This means that multiple tape drives on a SCSI bus can have their SCSI-status LEDs lit at the same time.

For detailed information about these integration issues, request the following white paper from Exabyte Technical Support or your account manager: WP9302A, *Optimizing SCSI On-Bus Operations (New SCSI Interface Microcode for 8mm Cartridge Tape Subsystems)* Exabyte Corporation, February 1993.



## 7.4 Other SCSI Configuration Options

Table 7-7 describes several other EEPROM options you can order to customize the SCSI configuration of your half-high tape drive. Refer to Section 2.4 for information about ordering EEPROM options.

**Table 7-7** EEPROM options for customizing the SCSI configuration

EEPROM option	Description	Possible values (default in bold)
<b>Synchronous negotiations</b>	Controls how the tape drive responds to the Synchronous Data Transfer Request (01h) message and whether the drive initiates synchronous data transfers.	<p><b>NORMAL</b> – The tape drive accepts <b>Synchronous Data Transfer Request messages, but does not initiate synchronous data transfers.</b></p> <p>NONE – The tape drive rejects Synchronous Data Transfer Request messages and does not initiate synchronous data transfers.</p> <p>INITIATE – The tape drive responds normally to synchronous negotiations and initiates synchronous negotiations with every initiator when first selected after a reset.</p>
<b>SCSI bus parity checking</b>	Enables or disables parity checking on the SCSI bus. When enabled, the tape drive checks every byte received across the SCSI bus for parity.	<p><b>ON</b> – Parity checking enabled</p> <p>OFF – Parity checking disabled</p>
<b>No disconnect during data transfer</b>	Controls whether the tape drive can disconnect from the SCSI bus during a data transfer.	<p><b>DISCONNECTS ALLOWED</b></p> <p>DISCONNECTS NOT ALLOWED</p>
<b>Even-byte disconnect</b>	Controls whether disconnects will occur on even-byte boundaries only or on any byte.	<p><b>ON</b> – Disconnect on even-byte boundaries only (2-byte or 4-byte, as determined by the following option).</p> <p>OFF – Disconnect on any byte.</p>
<b>EBD unit size</b>	Controls whether even-byte disconnects occur on two-byte or four-byte boundaries. This option applies only when even-byte disconnects are enabled.	<p><b>4 BYTES</b> – Even-byte disconnects occur on <b>four-byte boundaries.</b></p> <p>2 BYTES – Even-byte disconnects occur on two-byte boundaries.</p>

EEPROM option	Description	Possible values (default in bold)
<b>Command queuing</b>	Controls how the tape drive handles tape motion commands during power-on self-test, reset, and load operations or when it is executing an immediate command.	<p><b>QUEUE</b> – One tape motion command is queued until the current “immediate” operation is complete.</p> <p>BUSY – Commands are not queued. Busy status is returned.</p> <p>CHECK COND – Commands are not queued. Check Condition status is returned and the Sense Key is set to Not Ready.</p>
<b>Maximum reselection tries</b>	Controls the maximum number of times that the tape drive will attempt to reconnect to the initiator before giving up.	<p><b>0</b> – No limit on the number of attempts.</p> <p><i>n</i> – Stop after <i>n</i> attempts (between 1 and 255).</p>
<b>Reselection timeout</b>	Controls the amount of time before the tape drive will time out during an attempt to reconnect to the initiator.	<p><b>250 msec.</b></p> <p>5 msec.</p>

# 8

## Optimizing the Performance of Your Tape Drive

If you plan to create or modify a driver program for a half-high tape drive, you must consider how the drive interacts with the data being transferred to and from the host. By keeping a few tips in mind, you can maximize the amount of data that can be stored on each data cartridge and provide for ease of access to that data.

This chapter provides guidelines and tips for creating drivers that meet these goals, including:

- Optimizing the size of data blocks from the host
- Fine-tuning data transfers
- Effectively managing data on the tape

## 8.1 Optimizing the Size of Data Blocks from the Host

---

You may want to adjust the block size of the data being transferred from the host to the tape drive to use the maximum capacity of the data cartridge. If you are writing data to tape in 8200 format, block-size optimization is particularly important. If you are writing data in 8200c, 8500, or 8500c format, block-size optimization is not as crucial, but you can achieve somewhat greater capacity by using larger, rather than smaller, logical block sizes.

Each tape drive accepts *logical blocks* of data from 0 to 240 KBytes in size. The optimum size for a logical block transferred from the host is determined by how the drive records the data block to tape. Each tape drive records data to tape in *physical blocks*. These physical blocks do not vary in size. They consist of a fixed amount of data from the host along with header information, cyclic redundancy check (CRC) information, and error correction code (ECC) added by the drive:

<b>1 physical block =</b>	14 bytes of header information
	1,024 bytes of data from the host
	2 bytes of CRC information
	400 bytes of ECC
	<hr/>
	1,440 bytes total

## Optimizing Block Size: 8200 Format

---

If a logical block of host data in 8200 format does not fill the available space in a physical block, the tape drive pads the physical block with *gap bytes* consisting of null data. If a logical block of host data exceeds the amount of available space in a physical block, the drive splits the logical block among two or more physical blocks and pads the final physical block with gap bytes, if necessary.

Because gap bytes reduce the capacity of the tape, it is important to match the logical block size to the amount of data that the drive can record in each physical block.

The maximum amount of data that can be recorded in a single physical block of 8200 format data is 1,024 bytes. Only one or part of one logical block is recorded in each physical block. Thus, the optimum logical block size for data from the host is 1,024 bytes or exact multiples of 1,024. Any other logical block size reduces the capacity of the tape.

### Example

If the logical block size is set to 1,536 bytes, the following occurs during a multiple-block write operation:

- 1** The first physical block written to tape contains 1,024 bytes of data from the host.
- 2** The second physical block written to tape contains only 512 bytes of data from the host. The tape drive pads this physical block with 512 gap bytes to equal the required 1,024 bytes.
- 3** The third physical block written to tape contains 1,024 bytes of data from the host.
- 4** The fourth physical block contains 512 bytes of host data and 512 gap bytes.
- 5** The pattern is repeated until all of the logical blocks are written.

Because the block size (1,536 bytes) is not an exact multiple of 1,024, tape capacity is reduced by the addition of gap bytes. In this case, approximately one-fourth of the available tape capacity is wasted.

## Logical Block Packing: All Other Data Formats

---

The maximum amount of data that can be placed in a physical block to be written to tape in all tape drive data formats is 1,024 bytes. However, unlike a physical block of data in 8200 format, a physical block of data in all other formats (8200c, 8500, and 8500c) can contain one *or more* logical blocks of data from the host. For example, if a logical block from the host is 512 bytes, the tape drive places two of the 512-byte blocks in the physical block it writes to tape.

In each of these data formats, a logical block can start in one physical block and end in another physical block. For example, if a logical block from the host is 3,000 bytes, the tape drive places 1,024 bytes in the first physical block, 1,024 bytes in the second physical block, and 952 bytes in the third physical block. The next 3,000-byte logical block from the host starts immediately following the 952 bytes in the third physical block. Because no gap bytes are added to physical blocks, tape capacity is not significantly affected by the size of physical block sent by the host.

Although logical block packing prevents the loss of significant tape capacity, slight capacity may be lost when small block sizes are used. When packing more than two logical blocks in a single physical block, the tape drive adds a two-byte header to each logical block after the second block.

### Example

In an extreme case, suppose that the host is sending a series of one-byte logical blocks to the drive. Tape capacity is used as follows:

- 1** The tape drive places the first two one-byte data blocks in the 1,024-byte physical block. No header information is added to these blocks. This consumes two bytes of space in the physical block.
- 2** The drive then places the next 340 one-byte logical blocks into the physical block, adding two bytes of header information to each of the logical blocks. Therefore, these 340 one-byte data blocks consume 1,020 bytes of space in the physical block.
- 3** The drive adds two gap bytes to complete the 1,024-byte physical block.

Because of the extremely small logical block size, tape capacity is reduced by approximately two-thirds (342 bytes of user data stored in each physical block out of 1,024 bytes available).

## 8.2 Fine-Tuning Data Transfers

---

Each half-high 8mm tape drive contains a 1-MByte data buffer that enables it to operate as either a *streaming* device or a *start/stop* device, depending on the rate of data transfer to and from the host system. If your system permits, operating the drive in streaming mode can maximize the amount of data you can store on a tape and minimize the amount of wear on the tape and recording heads.

### Streaming Mode

When the tape drive is operating in streaming mode, it transfers data continuously between the buffer and tape without stopping tape motion.

**During a streaming write operation**, if the tape drive's buffer fills with data from the host faster than the drive can write the data to tape, the drive disconnects from the SCSI bus. The drive continues to write data to tape until the buffer has emptied to a certain level (the *reconnect threshold*). Then, the drive reconnects to the SCSI bus to accept more data.

**During a streaming read operation**, if the host can accept data from the tape drive's buffer faster than the drive can fill the buffer with data from the tape, the drive disconnects from the SCSI bus. The drive continues to read data into the buffer until the buffer is refilled to the reconnect threshold. Then, the drive reconnects to the SCSI bus to transfer more data.

### Start/Stop Mode

When the tape drive is operating in start/stop mode, it must stop and restart tape motion during write and read operations to accommodate the slower data transfer rate of the host.

**During a start/stop write operation**, the tape drive waits until the buffer is filled to a certain level (the *motion threshold*), starts the tape, and records the buffered data. After writing the data, the drive stops tape motion and waits for the buffer to fill to the motion threshold again.

**During a start/stop read operation**, the drive fills the buffer with data from the tape, stops the tape, waits for the host to accept enough data to empty the buffer to the motion threshold, then starts the tape and fills the buffer again.

Start/stop activity increases the amount of wear on the tape and the drive's recording heads. It also decreases the amount of data that can be stored on the tape because gap blocks and gap tracks are written to the tape whenever tape motion has to be stopped.

## Achieving Streaming Mode

---

Table 8-1 shows the data transfer rates that must be achieved to enable the tape drive to operate in streaming mode. If the host is capable, try to match or slightly exceed these data transfer rates.

**Table 8-1** Host data transfer rates required for streaming data

When the tape drive is operating in this data format...	Streaming data transfers are possible if the host can maintain or exceed this data transfer rate
8200	262.5 KBytes per second
8200c	500 KBytes per second (assuming a 2:1 compression ratio)
8500 (EXB-8505 and EXB-8505XL only)	500 KBytes per second
8500c (EXB-8505 and EXB-8505XL only)	1 MByte per second (assuming a 2:1 compression ratio)



## Adjusting the Motion and Reconnect Thresholds

Depending on whether your tape drive operates as a start/stop or streaming device, you may be able to increase the efficiency of data transfers to and from the tape drive's buffer by adjusting the motion threshold or reconnect threshold.

If your tape drive operates as a start/stop device, you can reduce the number of times the tape is started and stopped during read and write operations by adjusting the motion threshold. If your tape drive operates as a streaming device, you can reduce the number of disconnects and reconnects that occur by adjusting the reconnect threshold. You adjust these thresholds using the MODE SELECT command (see Table 8-3 on page 8-8), or you can request default values for these thresholds as an EEPROM option.

Table 8-2 summarizes the functions of the motion and reconnect thresholds.

**Table 8-2** Summary of motion and reconnect thresholds

	What it controls...	What it represents during a write operation...	What it represents during a read operation...
<b>Motion Threshold</b>	During start/stop operations, the starting and stopping of tape motion (buffer/tape data transfers)	The minimum amount of data that must be in the tape drive's buffer before tape motion starts and data is written to the tape	The minimum amount of space that must be available in the tape drive's buffer before tape motion starts and data is read from the tape
<b>Reconnect Threshold</b>	During streaming operations, the disconnects and reconnects between the tape drive and the host (host/buffer data transfers)	The minimum amount of space that must be available in the tape drive's buffer before the drive reconnects to the host and accepts more data	The minimum amount of data that must be in the tape drive's buffer before the drive reconnects to the host and transfers more data

If you feel that data transfers between a particular host and tape drive need to be fine-tuned, use the following rule-of-thumb to adjust the motion or reconnect threshold.

- If the data transfer rate is fast, raise the reconnect threshold.
- If the data transfer rate is slow, raise the motion threshold.

Table 8-3 indicates where you can set the motion and reconnect thresholds using the MODE SELECT command.

**Table 8-3** Where to set the motion threshold and reconnect threshold

To set this threshold...	Use any of these fields in the MODE SELECT command...	
	Page	Field
<b>Motion threshold</b>	(Non-page format)	Motion Threshold—Byte 02 of the vendor-unique parameters
	Device Configuration Page (Page Code = 10h)	Write Buffer Full Ratio—Byte 04 and Read Buffer Empty Ratio—Byte 05 (these values must be equal)
	Vendor Unique Parameters Page 1 (Page Code = 20h)	Motion Threshold—Byte 04
<b>Reconnect threshold</b>	(Non-page format)	Reconnect Threshold—Byte 03 of the vendor-unique parameters
	Disconnect-Reconnect Page (Page Code = 02h)	Buffer Full Ratio—Byte 02 and Buffer Empty Ratio—Byte 03 (these values must be equal)

## 8.3 Effectively Managing Data on the Tape

---

Exabyte half-high tape drives provide a number of features that help you manage data on the tape. By following the guidelines in this section, you can effectively organize the data being written to tape so that capacity is maximized and the data is easier to access. This section discusses the following topics:

- Compressing data
- Using partitions
- Appending data to a previously written tape
- Using high-speed search
- Obtaining error information

### Compressing Data

---

To compress data, the tape drive uses the Improved Data Recording Capability (IDRC) compression algorithm, licensed from IBM. During data compression, the drive uses its Compression Integrity Check™ feature to make sure that the compressed data can be accurately read from tape.

When data compression is in effect, the tape drive continually monitors the compression ratio to determine whether the size of each data block will actually decrease when compressed. If the size of a data block cannot be decreased (for example, if it has already been compressed by the initiator), the drive automatically turns off data compression until it encounters a data block that can be compressed.

**Note:** The benefit of data compression monitoring is seen only when data is transferred from the host in multiple logical blocks. If data is transferred a single block at a time, turning compression off for the next block has no performance effect (since there is no next block with the current command).

### Using the EXB-8205 or EXB-8205XL to Write Compressed Data

The EXB-8205 and EXB-8205XL write compressed data in 8200c format. Because this is the default data format for these drives, you do not need to issue any commands to write in this format. However, keep the following rules in mind:

- The EXB-8205 and EXB-8205XL allow only one format on any one tape. You must write the tape entirely in 8200c format or 8200 format.
- When writing to a new tape, you must specify the tape's format at the logical beginning of tape (LBOT). If you do not specify a format, the tape drive writes in its power-on default format. (The default format for the EXB-8205 and EXB-8205XL is typically 8200c. However, an EEPROM option allows you to choose whether the default data format is 8200 or 8200c.)
- To specify a data format other than the default, issue a MODE SELECT command.
- If you are appending data to a previously written tape, the tape drive automatically determines the tape format for you and writes in that format.
- When the tape drive is writing data in 8200c format, the data is always compressed. You cannot turn compression on and off.

### Using the EXB-8505 or EXB-8505XL to Write Compressed Data

The EXB-8505 and EXB-8505XL write data in four different formats, two of which are compressed: 8200c and 8500c. 8500c format is the default data format for the EXB-8505 and EXB-8505XL. When writing data with one of these drives, keep the following rules in mind:

- The EXB-8505 and EXB-8505XL allow only one format on any one tape. You must write the tape entirely in 8200c format, 8200 format, 8500c format, or 8500 format.
- When writing to a new tape, you must specify the tape's format at the logical beginning of tape (LBOT). If you do not specify a format, the tape drive writes in its power-on default format. (The default format for the EXB-8505 and EXB-8505XL is typically 8500c. However, an EEPROM option allows you to choose whether the default data format is 8200, 8200c, 8500, or 8500c.)
- To specify a data format other than the default, issue a MODE SELECT command.
- When writing data to a dual-partition tape, you must write in 8500c format.
- When the tape drive is writing data in 8200c format, the data is always compressed. You cannot turn compression on and off.
- When the tape drive is writing data in 8500c format, you can turn compression on and off at any point on the tape by issuing a MODE SELECT command.
- If you are appending data to a previously written tape, the tape drive automatically determines the tape format for you and writes in that format.

## Using Partitions (EXB-8505 or EXB-8505XL Writing in 8500c Format Only)

In 8500c format, the EXB-8505 and EXB-8505XL can write and read tapes containing up to two partitions. A partition is a self-contained writable and readable area on a tape. Partitioned tapes provide an efficient way to maintain a directory at the beginning of a tape.

Figure 8-1 shows the correspondence between the various areas on an unpartitioned tape and on a tape with two partitions. The first partition on a dual-partition tape is Partition 1, and the second partition is Partition 0.

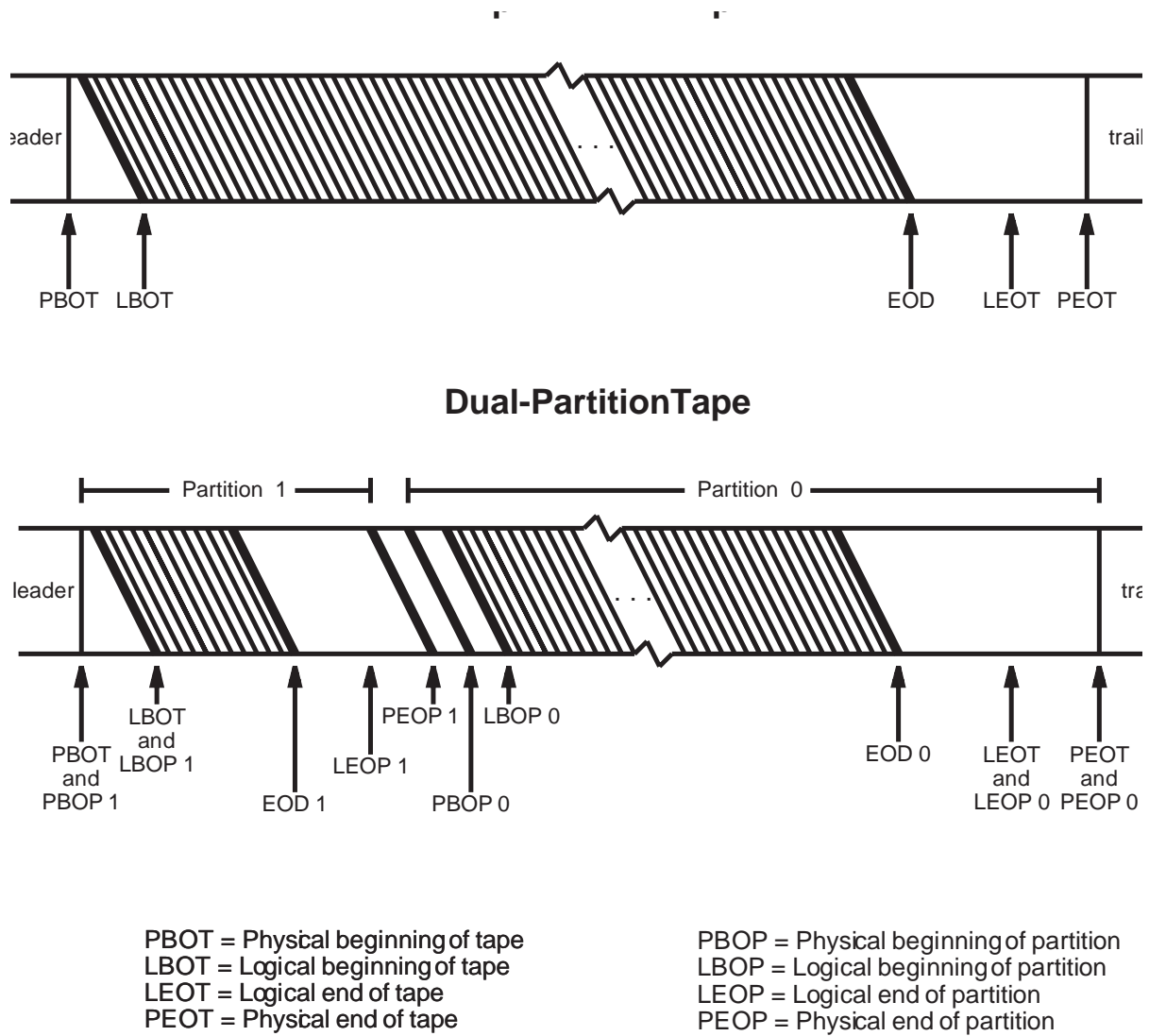

**Figure 8-1** Corresponding areas on an unpartitioned tape and a dual-partition tape

The following are brief summaries of operations you typically perform with partitions. For specific details about these operations, refer to the *EXB-8205 and EXB-8505 SCSI Reference*.

### Creating Partitions

To create a partitioned tape, format the tape using the MODE SELECT command. The MODE SELECT command lets you specify how many partitions will be on the tape (one or two) and what size the first partition will be (the size of the second partition is always the remainder of the tape).

### Loading a Partitioned Tape

You load a dual-partition tape exactly as you would a standard tape. However, you can use the MODE SELECT command to choose which partition the tape drive positions the tape to immediately after it is loaded. By default, the drive positions the tape to the second partition. The second partition is typically used as the data area, while the first partition is used as the directory for the tape. Because the drive positions the tape to the second partition by default, you can easily append data in the data area, then move back to the first partition to update the directory.

### Moving From One Partition to the Other

If you want to move the tape from one partition to the logical beginning of the other partition (LBOP), you can use the LOCATE command or the MODE SELECT command.

### Writing Data

To write data, use the WRITE command as you would with a standard tape. However, remember that if you want to write data in the partition the tape is not currently in, you must first change partitions using the LOCATE or MODE SELECT command.

Although partitions are treated as separate entities by the tape drive, you cannot use different data formats in the two partitions. If you attempt to change data formats between partitions, you will lose the partition information. Note, however, that you can turn compression on and off in 8500c format in either partition.

**Note:** When you are writing data to the first partition, you can never overwrite the end of the partition. If you encounter the physical end of the first partition, the tape drive reacts as if it encountered the physical end of the tape (PEOT). The write operation stops and any buffered data is not written to tape.

### **Locating Data Blocks**

Use the READ POSITION command to identify the logical position of a specific data block on a dual-partition tape just as you would on a standard tape. The READ POSITION data returned by the tape drive indicates the block address at the current logical location. It also indicates the number of the partition the tape is located in. When you use the LOCATE command to search for that logical position, you specify which partition the drive should search for the requested block.

### **Reading Data**

To read data, use the READ command just as you would with a standard tape. However, remember that if you want to read data in the partition the tape is not currently in, you must use the LOCATE or MODE SELECT command to reposition the tape to that partition. After you have issued a command to relocate to a new partition, you can use a LOCATE command or SPACE command to move the tape to a legal position for reading data.

### **Rewinding the Tape**

When you issue a REWIND command, the tape drive rewinds the tape to the beginning of the current partition. If the tape is positioned in the first partition, the drive rewinds the tape to the logical beginning of the tape (LBOT). If the tape is positioned in the second partition, the drive rewinds the tape to the logical beginning of the second partition (LBOP 0).

If you want to rewind to LBOT and the tape is positioned in the second partition, do not use the REWIND command. Instead, use the LOCATE command to position the tape to the beginning of the first partition (LBOP 1 or LBOT).

### **Erasing the Tape**

The ERASE command acts upon only one partition at a time. After erasing the partition, the tape drive rewinds the tape to the beginning of that partition. To erase the data from an entire tape without eliminating the partitions, you must erase both partitions separately.

### **Unloading the Tape**

The UNLOAD command works exactly as it would for a single-partition tape. You can issue the UNLOAD command from either the first or the second partition. The tape drive rewinds the tape to the physical beginning of tape (PBOT), unloads the tape from the tape path, and ejects the cartridge.



## Appending Data to a Previously Written Tape

Each tape drive can write data to a cartridge that already has data on it without overwriting the pre-existing data. A few restrictions apply:

- **Only one data format is permitted on any tape.** For example, if an EXB-8505 appends data to a tape that contains 8200 format data, the new data must also be in 8200 format. Note that the tape drive automatically determines the format of the data already on the tape; you cannot select a different format.
- **Data can be appended at certain tape positions only.** Depending on the data format, new data can be appended to old data at certain places only, as indicated in Table 8-4.

**Table 8-4** Where you can append new data on a previously written tape

If the tape is written in this data format...	Data can be appended at the...					
	End of data (blank tape)	EOD mark*	Beginning of a long filemark*	End of a long filemark	Beginning of a setmark*	End of a setmark
8200	✓		✓			
8200c		✓	✓			
8500 (EXB-8505 and EXB-8505XL only)		✓	✓	✓		
8500c (EXB-8505 and EXB-8505XL only)		✓	✓	✓	✓	✓

\* The EOD mark, long filemark, or setmark is overwritten as additional data is written to tape.

## High-Speed Search—Using the SPACE Command

The SPACE command enables you to perform high-speed positioning at 75 times the normal tape motion rate (10 times for 8200 format). Depending on the tape format, you can use the SPACE command to space forward or backward to logical blocks, filemarks, setmarks, and the end of data. Table 8-5 describes the different types of high-speed search space operations available.

**Table 8-5** High-speed search operations using the SPACE command

When the tape is written in this data format...	The following high-speed search operations are available...				
	Space forward or backward to a logical block	Space forward or backward to a filemark	Space forward or backward to a setmark	Space to end of data (blank tape)	Space to EOD mark
8200	✓*	✓	n/a	✓*	n/a
8200c	✓	✓		✓	
8500 (EXB-8505 and EXB-8505XL only)	✓	✓		✓	
8500c (EXB-8505 and EXB-8505XL only)	✓	✓		✓	

\* To perform this operation in 8200 format, you must have a special EEPROM image. See page 2-7 for information about ordering EEPROM images.

For detailed information about using the SPACE command, refer to the *EXB-8205 and EXB-8505 SCSI Reference*.

## High-Speed Search—Using the READ POSITION and LOCATE Commands

---

A typical scenario in which positioning at high speed is important is retrieving individual files from a tape. If a tape is formatted with two partitions, the first partition can contain a directory, while the second partition can contain all of the data files. By using the READ POSITION and LOCATE commands, you can establish an effective high-speed search method for accessing the files on such a tape. (Note that you do not have to use partitions to make effective use of the READ POSITION and LOCATE commands.)

A simple example of the steps involved in such an application follows:

- 1** Issue a MODE SELECT command to format a new tape to contain two partitions. The first partition will contain the master directory for the tape; the second will contain the data.
- 2** Write files to the second partition on the tape. At the beginning of each file, issue a READ POSITION command to determine the exact starting location of the file.
- 3** Store the READ POSITION data for each file in the initiator's memory.
- 4** Issue a MODE SELECT or LOCATE command to move to the first partition on the tape.
- 5** Write the information from the READ POSITION commands for all the files to the first partition. This becomes the master directory for the tape.
- 6** When you need to access a particular file on the tape, read the master directory to find out where that file is located. Then, issue a LOCATE command to position the tape at high speed to that file.

For detailed information about using the READ POSITION and LOCATE commands, refer to the *EXB-8205 and EXB-8505 SCSI Reference*.

**Note:** Partitions are available in 8500c format only. If you are writing data in any other format and want to set up a directory on the tape, request the directory support feature with your EEPROM image (see Section 2.4).

## Obtaining Status Information—Using the REQUEST SENSE, LOG SELECT, and LOG SENSE Commands

---

During tape drive operation, you may want to inquire about the status of the drive after processing a basic command, when an error condition has occurred, to check the settings for performing diagnostics, or to check on the number of read or write errors. Use the commands described below to obtain this information from the tape drive.

### REQUEST SENSE Command

When you receive a Check Condition status, use the REQUEST SENSE command to determine the type of error or to determine the tape drive's status. For errors, this command returns the following information:

- Sense key for the error that indicates the type of error (such as, Not Ready, Hardware Error, Illegal Request, Unit Attention, Aborted Command)
- Additional Sense Code (ASC) that indicates the type of error for the given sense key
- Additional Sense Code Qualifier (ASCQ) that indicates the specific error for the sense key and ASC
- Fault Symptom Code (FSC) that indicates the specific nature of hardware and software errors or other events (the FSC is an Exabyte-unique byte)

**Note:** The FSC can also be used to determine the location of errors in data sent with a LOG SELECT or MODE SELECT command.

### INQUIRY Command

You can use the INQUIRY command to obtain information about the tape drive's firmware level, the version of SCSI supported by the drive, and so on.

## LOG SENSE and LOG SELECT Command

The tape drive maintains the following read and write error recovery counters:

- Total number of rewrites
- Total number of rereads
- Total errors corrected
- Total times errors processed
- Total bytes processed
- Total unrecoverable errors

You can use the LOG SENSE command to retrieve the values of these counters. You can use the LOG SELECT command to specify cumulative and threshold values for these counters. By using these commands together, you can perform diagnostics, report statistical information on read and write error recovery procedures, and compare the cumulative value for any of the values to a threshold that you set. Comparing values is useful if you want the tape drive to notify you when a specific threshold value (for example, the total number of rewrites) has been reached.

For detailed information about using the REQUEST SENSE, LOG SELECT, and LOG SENSE commands, refer to the *EXB-8205 and EXB-8505 SCSI Reference*.

## Notes:

---

# 9

## Selecting and Maintaining Tapes

By selecting high-quality data cartridges and using proper storage techniques, you can expect a long shelf-life and optimal data integrity from the tapes you use in your tape drive. This chapter provides guidelines for selecting and maintaining tapes to meet the needs of reliable long-term storage.

## 9.1 Selecting Data Cartridges

---

After tape drive integration, selecting data cartridges is the next step in establishing an effective data storage system. By selecting appropriate 8mm data cartridges, you can achieve optimum data reliability, ensure tape durability, and minimize wear on tape drive recording heads.

### Data-Grade Tape or Video-Grade Tape?

---

The first decision in selecting 8mm data cartridges is whether to use data-grade or video-grade tape. **Exabyte strongly recommends data-grade tape** over video-grade tape for all data storage needs.

Data-grade tape is formulated specifically for high-performance data storage. It is designed to accommodate the density of data recorded by 8mm tape drives while minimizing the amount of wear inflicted on the drive's recording heads.

Video-grade tape is designed to accommodate different densities of information and to withstand different types of handling and storage. Video-grade tape formulations can be less accurate when recording high-density data and more abrasive to tape drive recording heads. In particular, **Exabyte strongly discourages use of the following types of video-grade tapes in the EXB-8205, EXB-8505, and XL drives:**

- ✗ **Extended-length video tapes (such as 135-, 140-, and 150-minute tapes).** The added length and the variation in positioning of the cartridge recognition holes can lead to unpredictable performance and unreliable detection of the cartridge. Furthermore, the increased length cannot be used by the tape drive for added data capacity.
- ✗ **Hi-8 metal particle (MP).** The magnetic properties of Hi-8 MP are significantly different from tape drive requirements and can cause increased error rates.
- ✗ **Hi-8 metal evaporative (ME).** The films used in Hi-8 ME tapes can experience cracking that reduces recording reliability and durability. Debris from the tape can reduce tape drive head life.
- ✗ **Hi-8 barium ferrite (BaFe).** Current formulations of Hi-8 BaFe tapes are not acceptable for any use in tape drives. Drive heads are not designed for this type of media.



## What Type of Data-Grade Tape?

---

Once you have decided to use data-grade tape, you will find a wide range of tape formulations to choose from. A number of 8mm tape cartridges are now marketed for data storage use. While they may be labeled “data grade” or “data quality,” some may actually contain only video-grade tape. Even tape that is acceptable for data storage can vary widely in consistency, durability, and long-term storage capability.

As an integrator, you may find that it is nearly impossible to evaluate all of the available data-grade tapes. Besides being time-consuming, it is very difficult to obtain a representative sampling of any one type of tape due to the variations inherent in the manufacturing process.

Because of the difficulty in evaluating the factors that make a tape appropriate for data storage, Exabyte continually tests tape technologies to determine the best formulation for use with Exabyte tape drives. In 1992, Exabyte introduced a new tape formulation that optimizes tape drive performance: the EXATAPE™ 8mm Data Cartridge. This data cartridge is the only cartridge recommended for use with the EXB-8205, EXB-8505, and XL tape drives.

## Why EXATAPE 8mm Data Cartridges?

---

The EXATAPE 8mm Data Cartridge offers the highest performance available for 8mm tape drives for the following reasons:

- **EXATAPE specifications are optimized for use in Exabyte products.** EXATAPE cartridges are the only data cartridges used in the design, testing, and manufacturing of all Exabyte products. The tape formulation is optimized for use with Exabyte’s recording technology, and the physical characteristics of the cartridge are optimized for the shape and handling methods of Exabyte tape drives.
- **EXATAPE quality is continually monitored and qualified in Exabyte tape drives.** Variability in the manufacturing process is eliminated, and consistency in magnetic characteristics, surface texture, and tape thickness is assured.

- **EXATAPE shelf life exceeds 30 years.** A special powder protects the tape's metal particles and creates a highly uniform recording surface. This ensures reliable recording and data preservation. Based on accelerated environmental tests, EXATAPE shelf life can be expected to exceed **30 years** when stored under recommended environmental conditions.
- **EXATAPE data cartridges withstand 1,500 tape passes.** Tests involving repeated tape passes, in which the entire tape is written or read, show that an EXATAPE data cartridge can withstand up to 1,500 passes when used according to recommendations.
- **EXATAPE surfaces reduce head and tape path wear and protect the tape from damage due to frictional changes.** The texture of the recording surface minimizes head wear. The backcoating prevents damage from repeated frictional changes associated with complex start/stop activity.
- **The EXATAPE cartridge shell maximizes tape protection.** The cartridge shell is highly heat-resistant to avoid physical deformation when exposed to high temperatures. It is also highly static-resistant to reduce the attraction of dust and debris that could contaminate the tape surface.
- **Each EXATAPE 8mm Data Cartridge comes with a limited lifetime warranty.** Each cartridge is warranted against defects in material and workmanship.

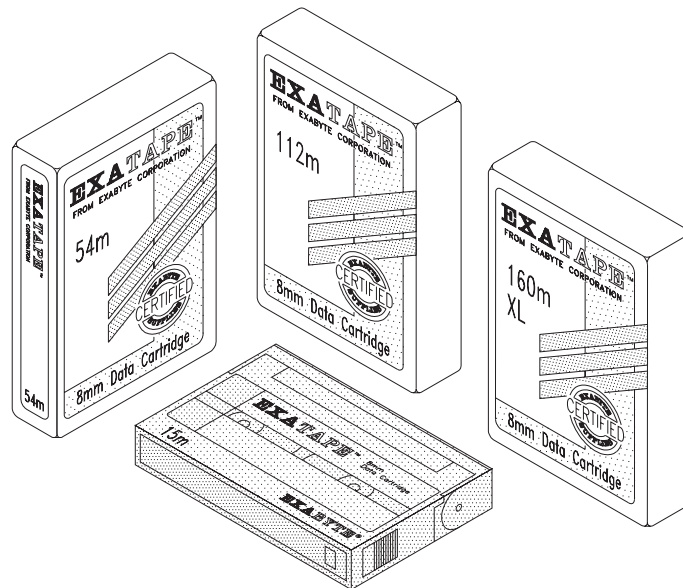

Figure 9-1 EXATAPE 8mm Data Cartridges

## Compatibility of EXATAPE 8mm Data Cartridges

EXATAPE 8mm Data Cartridges are available in four lengths: 15m, 54m, 112m, and 160m XL. The EXB-8205XL and EXB-8505XL support all four lengths. The EXB-8205 and EXB-8505 do not support the 160m XL tape. If you attempt to load any 160m data cartridge into an EXB-8205 or EXB-8505, the drive automatically ejects the cartridge.

**Important** EXATAPE 160m XL 8mm Data Cartridges are intended for use in the EXB-8205XL and EXB-8505XL only. The 160m XL tape is equipped with a Recognition System stripe, located on the tape leader, that enables the XL tape drives to recognize the tape as data-quality metal-particle media.

To prevent the use of inappropriate media, the XL tape drives do not accept 160m tapes without the Recognition System stripe. If you attempt to load a 160m tape without this stripe, the XL drive automatically ejects it.

### CAUTION

Do not use the 160m XL cartridge in Exabyte full-high tape drives (EXB-8200, EXB-8200SX, EXB-8500, and EXB-8500c). Although these tape drives will accept the 160m XL cartridge, these cartridges are not supported by these drives and should not be used.

Table 9-1 summarizes the compatibility of EXATAPE 8mm data cartridges with Exabyte 8mm tape drives.

**Table 9-1** Compatibility of EXATAPE 8mm Data Cartridges and Exabyte 8mm tape drives

	EXATAPE 8mm Data Cartridge			
	15m	54m	112m	160m XL
EXB-8205 and EXB-8505	✓	✓	✓	not supported (automatically ejected)
EXB-8205XL and EXB-8505XL	✓	✓	✓	✓
EXB-8200 and EXB-8200SX	✓	✓	✓	not supported
EXB-8500 and EXB-8500c	✓	✓	✓	not supported

## Conditioning Non-EXATAPE Data Cartridges

---

**EXATAPE 8mm Data Cartridges do not require conditioning before use.** If, for some reason, you need to use data cartridges other than EXATAPE cartridges in an Exabyte tape drive, it is **highly recommended** that you condition those tapes before using them for data storage. Tapes from other manufacturers may contain manufacturing-generated debris and may shed a certain amount of debris from the tape edges during the first few uses. Conditioning these tapes will remove this debris.

**General Rule:** Any data cartridge other than an EXATAPE cartridge should undergo at least four, but not more than twenty, full passes before being used for data storage.

### Procedure for Conditioning a Tape

Perform tape conditioning on a tape drive that is operating within specifications with no history of tape damage. To condition a new tape, follow these steps:

- 1 Acclimate the tape to its environment.** If you have brought the tape from an environment with a temperature or humidity different from the environment you will condition it in, allow at least 24 hours for the tape to stabilize in the new environment.
- 2 Read and write data for a total of four tape passes.** Using normal tape motion commands, write data to the tape and read the data to gather error statistics. Do this from the beginning of the tape to the end of the tape in streaming mode for at least four full passes (two writes and two reads).
- 3 Check the error statistics and inspect the data cartridge.**
  - Analyze the error statistics. Set an error threshold that is suitable for your needs. If the errors are higher than this threshold, discard the cartridge.
  - Visually inspect the tape on the tape reel through the window. If you see staggered wraps, discard the cartridge.
  - Examine the outside of the data cartridge for physical damage. If you see any damage, discard the data cartridge.

## 9.2 Maximizing Tape Life by Minimizing Tape Passes

---

Whether a backup strategy involves just one tape or a number of tapes in a rotation scheme, reliability and economy are always important goals. These goals are best achieved by obtaining the maximum life from each tape.

One of the keys to maximizing tape life is to implement a backup application that minimizes unnecessary tape passes. A *tape pass* is defined as one pass of a particular area of tape over the heads under tension. EXATAPE 8mm Data Cartridges are designed to withstand approximately 1,500 tape passes when stored and handled as recommended.

Applications that cause the fewest tape passes are those that minimize start/stop activity (see the explanation of start/stop and streaming activity in Section 8.2 starting on page 8-5). Figure 9-2 on the following page demonstrates tape movement during a start/stop write operation. As shown in the figure, each start/stop event results in *three* passes over a portion of the tape:

- (1) The tape drive writes all of the data in its buffer to the tape. When the buffer is empty, the tape drive writes gap blocks and tracks to provide a gap area that aids in tape repositioning for the next write operation (*pass 1*).
- (2) The drive stops tape motion while the buffer refills to the motion threshold. During this time, the drive repositions the tape so that the write head is at the proper location for appending data. To do this, the drive first moves the tape backward a certain distance (*pass 2*).
- (3) When the motion threshold is exceeded, the drive finishes repositioning the tape by moving the tape forward. This allows the tape to come up to speed and matches the position of the write head to the location of the last gap track (*pass 3*). Data is then appended immediately following the last gap track.

In contrast, during a streaming write operation, only one tape pass occurs over any particular area of the tape. This is because the tape drive never has to stop tape motion and reposition to accommodate a slow data transfer rate.

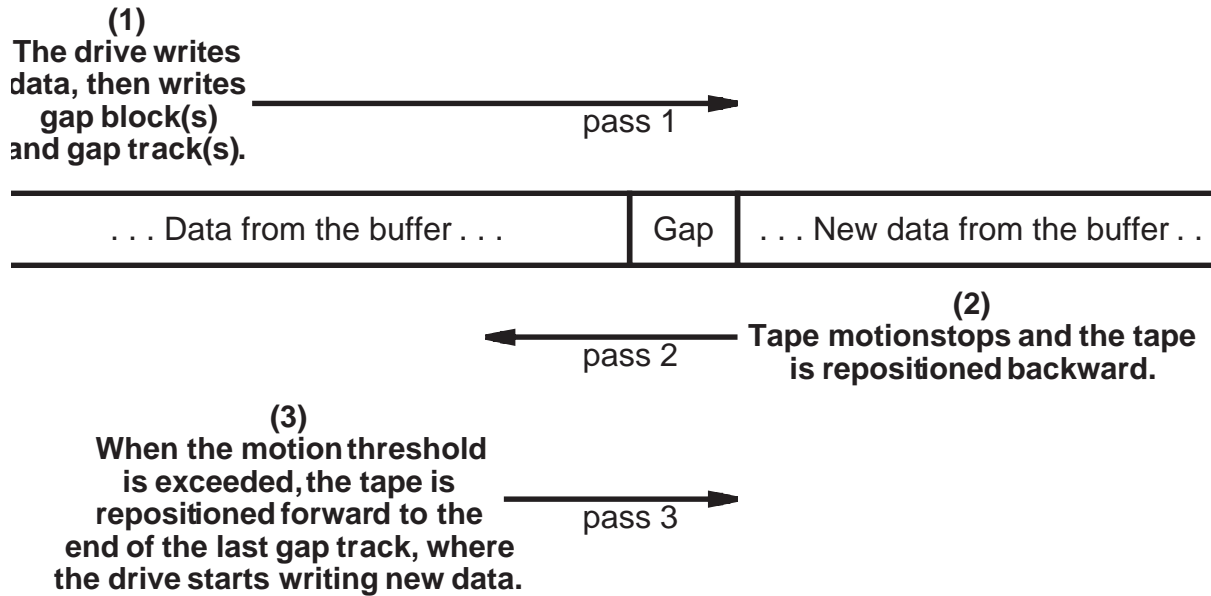

Figure 9-2 Tape passes during a start/stop write operation

## Estimating the Number of Tape Passes

You can estimate the number of passes a tape will undergo by analyzing the types of motions that an application requires. Table 9-2 provides guidelines for determining how many tape passes result from various types of motions.

Table 9-2 Number of tape passes associated with various types of tape activity

This tape activity...	Requires this many tape passes...
Writing or reading in streaming mode	1
Writing or reading in start/stop mode	3
Spacing forward by blocks	1
Spacing backward by blocks	2
Spacing or searching forward by filemark	3
Spacing or searching backward by filemark	2
Using the LOCATE command to position forward to a logical block	3
Using the LOCATE command to position backward to a logical block	2

Note that tape passes are not additive unless they are concentrated in the same location. Because the tape motions listed in Table 9-2 can occur anywhere on the tape, a succession or combination of such motions does not mean that the tape has accumulated the total number of passes associated with each motion. Typically, when several complex tape motions are combined, the number of passes is equal to that of the motion with the highest pass count.

## 9.3 Storing and Maintaining Archived Tapes

---

The key to maximizing the shelf life of your archived tapes is to store and maintain them properly. Managing archived tapes involves the following tasks:

- Establishing and maintaining a suitable storage environment
- Labeling the cartridges and maintaining a storage log
- Using the write-protect switch to prevent erasures and overwrites
- Storing data cartridges immediately after use
- Storing the data cartridges in the proper position
- Testing tapes regularly and replacing them if necessary

### Establishing and Maintaining a Suitable Environment

---

The storage environment is the single-most important factor affecting the shelf life of data cartridges. Temperature, humidity, and particulate contamination must be monitored and maintained at the levels described in this section to maximize tape life.

Ideally, the storage location's temperature and humidity should be maintained at the same levels as in the operating environment of the tape drive that recorded the data. However, this holds true only if the operating environment is maintained at recommended levels, as described in Chapter 4. If the operating environment cannot be maintained at recommended levels, it is better to keep the tape storage location at the levels described in this section rather than changing them to match the operating environment.

### Temperature and Humidity

Temperature and humidity must be maintained at a constant level to reduce stress on the tapes. Table 9-3 lists the recommended temperature and humidity range for data cartridge storage.

**Table 9-3** Recommended temperature and humidity for data cartridge storage

	Acceptable range
<b>Ambient temperature</b>	+5° C to +32° C (+41° F to +90° F)
<b>Relative humidity</b>	20% to 60% non-condensing

**Note:** “Acceptable range” does not mean that the temperature and humidity may fluctuate within this range; only that a steady temperature and humidity within this range must be maintained.

### Particulate Contamination

The data cartridge storage location must be as free of airborne debris as possible. Particulate contamination in data cartridges can prevent error-free read-back of data from the tape. In addition, debris may be transferred to the tape drive causing damage to the heads and other parts of the tape path.

To eliminate obvious sources of particulate contamination, follow these basic rules:

- Do not permit anyone to smoke, eat, or drink near the data cartridge storage area.
- Do not store data cartridges near a copier or printer; paper and toner dust can quickly contaminate the tapes.



## Labeling the Data Cartridges and Maintaining a Storage Log

---

Numerous strategies exist for backing up files, individual devices, and networks. Whatever backup strategy you use, labeling and logging are the key to being able to retrieve information from the tape. You need a system that allows you to determine the location of individual files on tapes.

Some suggestions for information to record on the data cartridge label include:

- Data cartridge number (log number)
- Date backup was performed
- Format of the data on the tape (8500, 8500c, 8200, or 8200c)

Some suggestions for information to record in the storage log include:

- Data cartridge number (log number)
- Date backup was performed
- Format of the data on the tape (8500, 8500c, 8200, or 8200c)
- Location (in a data cartridge magazine for example)
- Contents (what files are on the tape)
- History of the tape's use
- Model and serial number of the drive the tape was recorded on
- Error statistics

## Using the Write-Protect Switch

---

An 8mm data cartridge is equipped with a write-protect switch to prevent unintentional overwriting of data on the tape. Figure 9-3 shows the location of the write-protect switch.

To set the write-protect switch, use a ballpoint pen or other suitable instrument to move the red switch to the desired position.

When the red switch is fully visible (that is, the opening at the bottom of the data cartridge is covered), the data cartridge is write-protected and cannot be written to or erased. Conversely, when the red switch is not visible (the opening is not covered), the data cartridge is write-enabled and can be written to or erased.

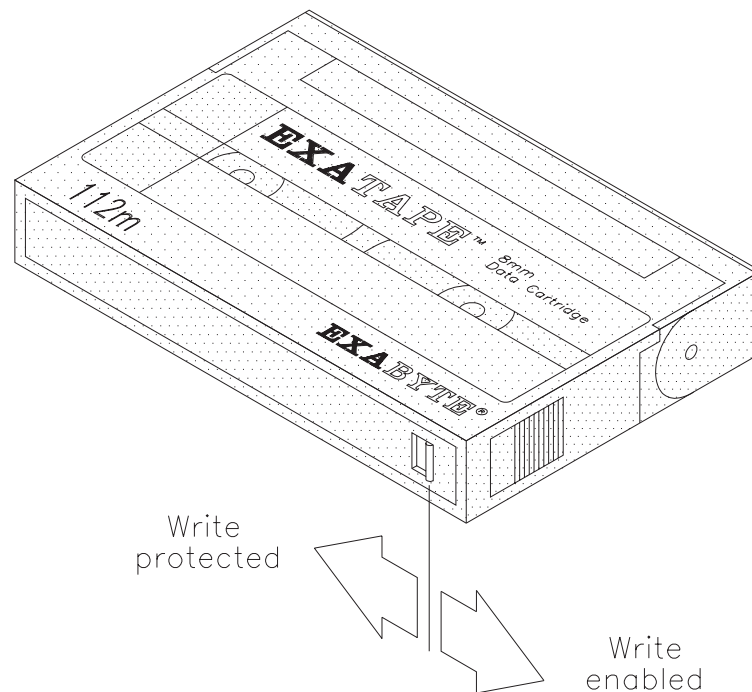

**Figure 9-3** Write-protect switch on the bottom of an 8mm data cartridge

## Storing Data Cartridges Immediately

Store data cartridges as soon as possible after you have archived data to them. Immediate storage helps avoid many of the conditions that can damage tapes, such as temperature and humidity fluctuations, particulate contamination, and excessive handling.

## Storing Data Cartridges in the Proper Position

A data cartridge must be stored on one of its long edges, not flat on its side. As shown in Figure 9-4, when a data cartridge is stored on its side, the tape inside the data cartridge is actually on its edge. When the tape is on its edge, stress builds up along the edges. Damage to the edges can result, leading to the shedding of debris. For the same reason, never stack data cartridges on top of each other or lean them at an angle for extended periods of time.

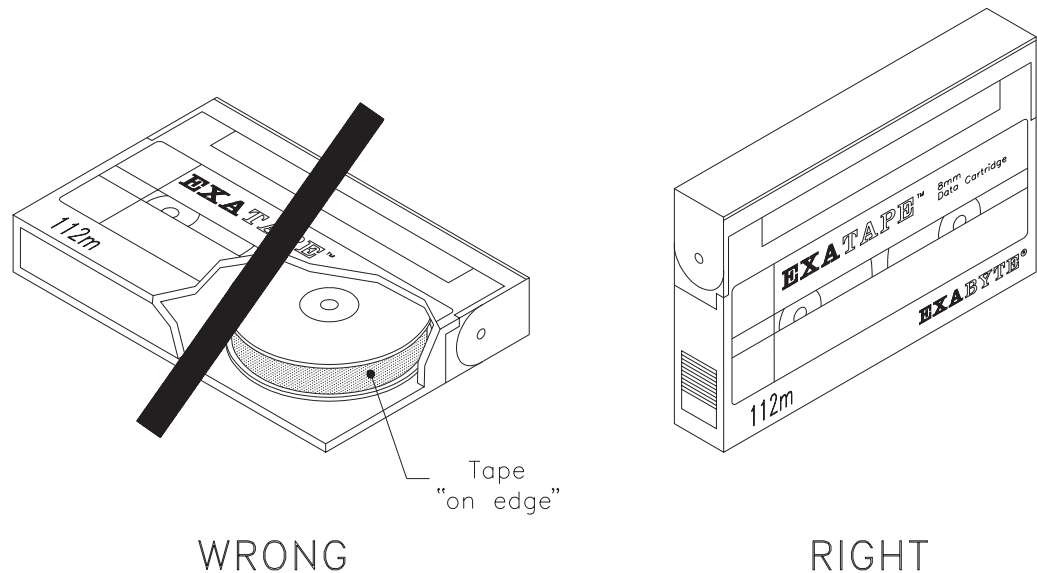

**Figure 9-4** Do not store a data cartridge on its side. When the tape inside the data cartridge is “on edge,” damage can result.

### Exabyte 8mm Data Cartridge Magazine

To make data cartridge storage easier, Exabyte provides 8mm data cartridge magazines that hold ten 8mm data cartridges each. Data cartridges are held in the proper position (on a long edge) and are protected from airborne contaminants by a clear plastic cover. With the cover in place, the magazines can be stacked on top of each other to make the most efficient use of storage space. A label for the end of the magazine is included with each 8mm data cartridge magazine. Figure 9-5 shows the 8mm magazine with and without the cover.

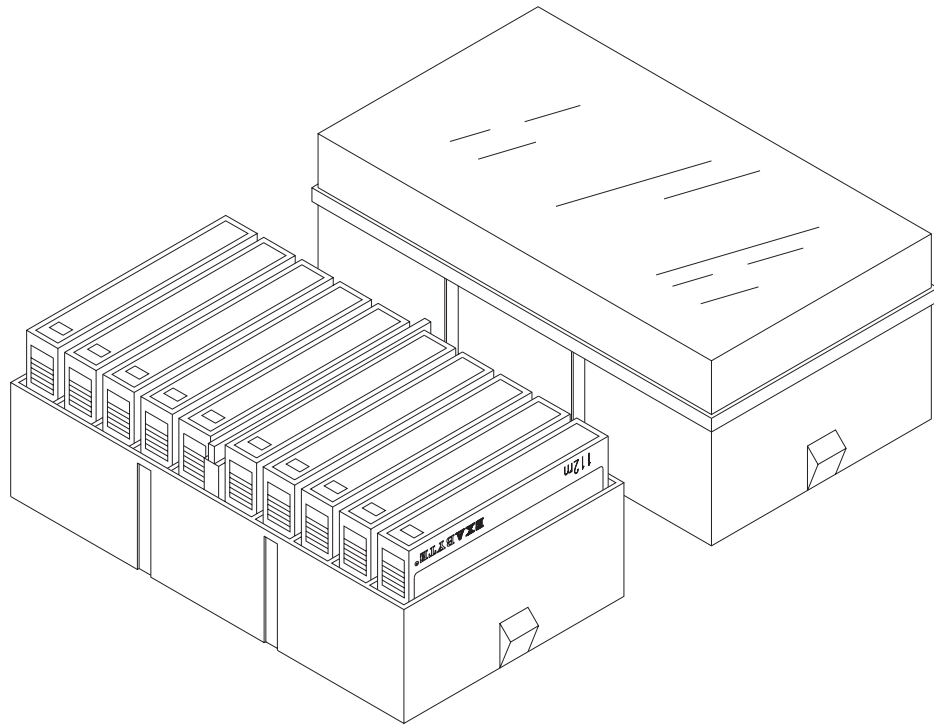

**Figure 9-5** Exabyte 8mm Data Cartridge Magazines

As an added feature, Exabyte 8mm Data Cartridge Magazines are designed to fit directly into Exabyte 8mm automated tape libraries. If you currently use an Exabyte tape library or plan to use one in the future, you can use the magazines both for cartridge storage and for easy loading and unloading of tapes in your library.

**Note:** Exabyte libraries for full-high 8mm tape drives require different magazines than Exabyte libraries for half-high 8mm tape drives. If you plan to use your magazines in a library, check with your account manager to determine the type of magazine you need to match your library.

**EXAPAK®**

The EXAPAK, available from Exabyte, provides a way to obtain data cartridges, a data cartridge magazine, and a cleaning cartridge in one package. Each EXAPAK contains nine EXATAPE 8mm Data Cartridges and one Exabyte 8mm Cleaning Cartridge. Labels for each of the cartridges and the data cartridge magazine are included. If you plan to use the EXAPAK magazine in an Exabyte automated tape library, check with your account manager to determine the type of EXAPAK you need to match your library.

## Replacing Data Cartridges

---

Approximately once each year, you may want to run each tape through a full pass and check its error statistics. If errors have increased significantly since the previous test or if they exceed a certain predetermined threshold, you should re-archive the data to a new tape and discard the old tape.

**CAUTION**

If you have any data stored on tapes other than EXATAPE 8mm Data Cartridges, be sure to perform this yearly testing to reduce stress on the inner wraps of these tapes. When stored for long periods of time, some tapes can build up stress on the inner wraps on the tape spools. In tapes from some manufacturers, this stress can lead to tape damage and the shedding of debris, which can damage the tape drive. To reduce the chances of this type of damage, always use EXATAPE 8mm data cartridges in your tape drives.

**Notes:**

---

# Glossary

- 8200 format** A non-compressed data format written and read by the EXB-8200, EXB-8200SX, EXB-8205, EXB-8205XL, EXB-8500, EXB-8500c, EXB-8505 and EXB-8505XL.
- 8200c format** A compressed data format written and read by the EXB-8205, EXB-8205XL, EXB-8500c, EXB-8505, and EXB-8505XL.
- 8500 format** A non-compressed data format written and read by the EXB-8500, EXB-8500c, EXB-8505, and EXB-8505XL.
- 8500c format** A compressed data format written and read by the EXB-8500c, EXB-8505, and EXB-8505XL.
- ANSI** American National Standards Institute.
- ASC** Additional Sense Code. This byte is returned as byte 12 of the REQUEST SENSE extended sense data. The ASC, in conjunction with the Additional Sense Code Qualifier (ASCQ), provides additional information about each sense key.

<b>ASCQ</b>	Additional Sense Code Qualifier. This byte is returned as byte 13 of the REQUEST SENSE extended sense data. The ASCQ, in conjunction with the Additional Sense Code (ASC), provides additional information about each sense key.
<b>ATN</b>	Attention signal. The SCSI bus signal asserted by the initiator to indicate that it has a message to transmit to the target.
<b>AWG</b>	American Wire Gauge.
<b>b</b>	Binary (base 2) numbering system.
<b>BOT</b>	Beginning of tape.
<b>BSY</b>	Busy bus condition.
<b>bus devices</b>	Initiator or target devices connected to the SCSI bus.
<b>byte</b>	Eight bits or one character.
<b>C</b>	Celsius (Centigrade).
<b>Canadian DOC</b>	Canadian Department of Communications.
<b>cm</b>	Centimeter (0.3937 inches).
<b>Compression Integrity Check™</b>	The function performed within the tape drive's compression circuit to ensure that compressed data can be accurately read from tape.
<b>connect</b>	The establishment of communications between the initiator and the selected target.
<b>CRC</b>	Cyclic redundancy check.
<b>CSA</b>	Canadian Standards Association.
<b>CTS</b>	Cartridge Tape Subsystem. For example, the EXB-8205 and EXB-8505.
<b>disconnect</b>	The termination of communications between the initiator and the target. During a disconnect, the target releases control of the SCSI bus, allowing the bus to become free.
<b>early warning</b>	The logical end of tape (LEOT) or logical end of partition (LEOP).
<b>ECC</b>	Error correction code.



<b>ECMA</b>	European Computer Manufacturers Association.
<b>EEPROM</b>	Electrically erasable programmable read-only memory.
<b>EPROM</b>	Erasable programmable read-only memory.
<b>EOD</b>	End of data.
<b>EOP</b>	End of partition.
<b>EOT</b>	End of tape.
<b>EXATAPE</b>	A data-grade rewritable 8mm data cartridge that is recommended for use in all Exabyte 8mm tape drives.
<b>EXB-8200</b>	The EXB-8200 8mm Cartridge Tape Subsystem. The EXB-8200 is a 5.25-inch full-high tape drive that can store up to 2.5 gigabytes of data on an EXATAPE 112m 8mm Data Cartridge.
<b>EXB-8205</b>	The EXB-8205 8mm Cartridge Tape Subsystem. The EXB-8205 is a 5.25-inch half-high tape drive that can store up to 5.0 gigabytes of data on an EXATAPE 112m 8mm Data Cartridge, assuming an average 2:1 compression ratio.
<b>EXB-8205XL</b>	The EXB-8205XL 8mm Cartridge Tape Subsystem. The EXB-8205XL is an EXB-8205 configured with the “eXtended-Length” media feature. The EXB-8205XL can store up to 7.0 gigabytes of data on an EXATAPE 160m XL 8mm Data Cartridge, assuming an average 2:1 compression ratio.
<b>EXB-8200SX</b>	The EXB-8200SX 8mm Cartridge Tape Subsystem. The EXB-8200SX is very similar to the EXB-8200 but offers a high-speed search capability.
<b>EXB-8500</b>	The EXB-8500 8mm Cartridge Tape Subsystem. The EXB-8500 is a 5.25-inch full-high tape drive that can store up to 5.0 gigabytes of data on an EXATAPE 112m 8mm Data Cartridge.

**EXB-8500c** The EXB-8500c 8mm Cartridge Tape Subsystem. The EXB-8500c is physically similar to the EXB-8500, but offers data compression as an option. Assuming an average ratio of 2:1, the EXB-8500c can store up to 10.0 gigabytes of data on an EXATAPE 112m 8mm Data Cartridge.

**EXB-8505** The EXB-8505 8mm Cartridge Tape Subsystem. The EXB-8505 is a 5.25-inch half-high 8mm tape drive that can store up to 10.0 gigabytes of data on a 112m EXATAPE 8mm Data Cartridge, assuming an average 2:1 compression ratio.

**EXB-8505XL** The EXB-8505XL 8mm Cartridge Tape Subsystem. The EXB-8505XL is an EXB-8505 configured with the “eXtended-Length” media feature. The EXB-8505XL can store up to 14.0 gigabytes of data on an EXATAPE 160m XL 8mm Data Cartridge, assuming an average 2:1 compression ratio.

**F** Fahrenheit.

**FCC** Federal Communications Commission.

**FSC** Fault Symptom Code. This byte is returned as byte 28 of the REQUEST SENSE extended sense data. The FSC is an Exabyte-unique byte used to indicate the specific nature of hardware and software errors or other events.

**GByte** Gigabyte.

**h** Hexadecimal (base 16) numbering system.

**host** The computer system that acts as the initiator of an operation.

**Hz** Hertz.

**ID** Identification.

**IDRC** Improved Data Recording Capability. The compression algorithm licensed from IBM and used by the EXB-8205, EXB-8205XL, EXB-8505, EXB-8505XL, and EXB-8500c.

**IEC** International Electrotechnical Commission.

**initiator** A host computer system that requests an operation to be performed by the target.

<b>ISO</b>	International Standards Organization.
<b>KByte</b>	Kilobyte.
<b>LBOP</b>	Logical beginning of partition.
<b>LBOT</b>	Logical beginning of tape.
<b>LEOP</b>	Logical end of partition.
<b>LEOT</b>	Logical end of tape.
<b>LUN</b>	Logical unit number.
<b>MByte</b>	Megabyte.
<b>mm</b>	Millimeter (0.03937 inches).
<b>motion threshold</b>	<p>During a start/stop write operation, the minimum amount of data that must be in the tape drive's buffer before data in the buffer will be written to tape.</p> <p>During a start/stop read operation, the minimum amount of free space that must be in the tape drive's buffer before more data will be transferred from the tape to the buffer.</p> <p>The motion threshold is measured in 4-KByte increments. See also <i>reconnect threshold</i>.</p>
<b>ms or msec</b>	Millisecond.
<b>μm</b>	Micrometer (0.00003937 inches).
<b>μs or μsec</b>	Microsecond.
<b>ns</b>	Nanosecond.
<b>NSTA</b>	National Safe Transit Association.
<b>partition</b>	A self-contained writable and readable area on a tape. The EXB-8505 and EXB-8505XL support up to two partitions on a tape. Each partition has a physical and logical beginning (PBOP and LBOP) and a physical and logical end (PEOP and LEOP).
<b>PBOP</b>	Physical beginning of partition.
<b>PBOT</b>	Physical beginning of tape.

<b>PEOP</b>	Physical end of partition.
<b>PEOT</b>	Physical end of tape.
<b>POST</b>	Power-on self-test, which is the process that occurs when the tape drive performs its initial power-on diagnostics.
<b>ready</b>	The state of the tape drive when it is ready to process commands.
<b>reconnect</b>	The function that occurs when the target arbitrates and reconnects to an initiator after a disconnect.
<b>reconnect threshold</b>	<p>When a disconnect occurs during a streaming write operation, the minimum amount of free space that must be in the tape drive's buffer before the drive reconnects to the initiator and data transfer from the initiator to the buffer resumes.</p> <p>When a disconnect occurs during a streaming read operation, the minimum amount of data that must be in the tape drive's buffer before the drive reconnects to the initiator and data transfer from the buffer to the initiator resumes.</p> <p>The reconnect threshold is measured in 3-KByte increments. See also <i>motion threshold</i>.</p>
<b>SCSI</b>	Small Computer System Interface.
<b>SCSI address</b>	An octal representation of the unique address (0-7) assigned to a SCSI device.
<b>SCSI ID</b>	The bit significant representation of the SCSI address referring to one of the signal lines.
<b>status</b>	Information sent from the target to the initiator upon completion of a command.
<b>target</b>	A bus device (usually a peripheral device) that performs an operation requested by an initiator. The EXB-8205, EXB-8205XL, EXB-8505, and EXB-8505XL are targets.

# Index

## A

Additional Sense Code (ASC) 8-18  
 Additional Sense Code Qualifier (ASCQ) 8-18  
 agency standards 4-20  
 air flow requirements 4-15  
 appending data 8-15  
 ASC 8-18  
 ASCQ 8-18

## B

backup applications 1-4  
 blocks (data) 8-2 to 8-4  
 bus phases (SCSI) 7-2 to 7-3

## C

cartridges  
   *See* data cartridges  
 chassis grounding 4-18  
 cleaning 5-1 to 5-6  
 cleaning cartridge 5-4 to 5-5  
 commands (SCSI) 7-4 to 7-6  
 compatibility  
   data cartridges 9-2 to 9-5  
   read/write 2-5  
 compression 8-9 to 8-11  
 configurations 2-8 to 2-13

## D

data cartridge magazine 9-14 to 9-15  
 data cartridges  
   160m XL 9-5  
   compatibility 9-2 to 9-5  
   conditioning 9-6  
   labeling 9-11  
   managing 9-1 to 9-16  
   replacing 9-15  
   selecting 9-2 to 9-5  
   storing 9-9 to 9-15  
   tape passes 9-7 to 9-9  
   write-protect switch 9-12

data formats 2-5 to 2-6  
 design verification testing 3-2 to 3-6  
 disconnecting (from SCSI bus) 7-9  
 DVT 3-2 to 3-6

## E

EEPROM options 2-7, 7-10 to 7-14  
 electromagnetic compatibility 4-21  
 electrostatic discharge 4-20  
 EMC 4-21  
 enclosures for tape drives 4-4 to 4-7  
 engineering verification testing 3-2  
 environmental requirements 4-14 to 4-17  
 ERASE command 7-4, 8-14  
 error information 8-18 to 8-19  
 ESD 4-20  
 EVT 3-2  
 Exabyte 8mm Cleaning Cartridge 5-4 to 5-5, 9-15  
 Exabyte 8mm Data Cartridge Magazine  
   9-14 to 9-15  
 EXAPAK 9-15  
 EXATAPE 160m XL 8mm Data Cartridge 9-5  
 EXATAPE 8mm Data Cartridge 9-3 to 9-5, 9-15  
 eXtended-Length (XL) tape drives  
   *See* XL tape drives

## F

features 2-1 to 2-18  
 formats, data 2-5 to 2-6  
 formatting partitions 8-13

## G

grounding 4-18

## H

hardware integration 4-1 to 4-22  
 help, how to get 1-1 to 1-4  
 hierarchical storage management 2-14 to 2-17  
 high-speed search 8-16 to 8-17  
 HSM  
   *See* hierarchical storage management  
 humidity requirements 4-14

**I**

INQUIRY command 7-4, 8-18  
 installation  
   enclosures 4-4 to 4-7  
   mounting requirements 4-2 to 4-3  
   power requirements 4-18  
   SCSI 4-8 to 4-13

**J**

jumper block, SCSI ID 4-12 to 4-13  
 jumpers (for setting SCSI ID) 4-12 to 4-13

**L**

LOAD/UNLOAD command 7-4, 8-14  
 LOCATE command 7-4, 8-13 to 8-14, 8-17  
 LOG SELECT command 7-4, 8-19  
 LOG SENSE command 7-4, 8-19  
 logical block packing 8-4  
 logical blocks 8-2 to 8-4

**M**

magazine, data cartridge 9-14 to 9-15  
 maintenance 5-1 to 5-6  
 messages, SCSI 7-7 to 7-8  
 Mini Tabletop Cartridge Tape Subsystem  
   4-4 to 4-7  
 MODE SELECT command 6-3, 7-4, 8-7 to 8-8,  
   8-10 to 8-11, 8-13 to 8-14, 8-17 to 8-18  
 MODE SENSE command 6-6, 7-4  
 motion threshold 8-5 to 8-8  
 mounting requirements 4-2 to 4-3

**N**

near-online storage 2-16

**O**

offline storage 2-16  
 on-going reliability testing 3-2  
 online storage 2-16  
 operating environment 4-14  
 operation 8-1 to 8-20  
 ORT 3-2

**P**

particulate contamination 4-15  
 partitions 8-12 to 8-14  
 physical blocks 8-2 to 8-4  
 power cable 4-19  
 power connector 4-19  
 power requirements 4-18  
 power supply 4-18  
 PREVENT/ALLOW MEDIUM REMOVAL  
   command 7-5  
 process verification testing 3-2  
 PVT 3-2

**R**

R-packs 4-9 to 4-10  
 radiated susceptibility 4-21  
 READ BLOCK LIMITS command 7-5  
 READ BUFFER command 7-5  
 READ command 6-2, 7-5, 8-14  
 READ POSITION command 7-5, 8-14, 8-17  
 RECEIVE DIAGNOSTICS RESULTS  
   command 7-5  
 reconnect threshold 8-5 to 8-8  
 regulatory agency standards 4-20  
 RELEASE UNIT command 7-5  
 remote switch (for setting SCSI ID) 4-12 to 4-13  
 REQUEST SENSE command 5-3, 7-5, 8-18  
 RESERVE UNIT command 7-5  
 resistor terminators 4-9 to 4-11  
 resources, Exabyte 1-1 to 1-4  
 REWIND command 6-3, 7-5, 8-14

**S**

safety agency standards 4-20  
 SCSI  
   bus phases 7-2 to 7-3  
   cable 4-8 to 4-9  
   cable connector 4-9  
   commands 7-4 to 7-6  
   configuration options 7-13 to 7-14  
   disconnecting from bus 7-9  
   EEPROM options 2-7, 7-10 to 7-14  
   ID, setting 4-12 to 4-13  
   improved performance 7-10 to 7-12  
   installation 4-8 to 4-13  
   messages 7-7 to 7-8  
   overview 7-1 to 7-14  
   status 7-6  
   termination of bus 4-9 to 4-11

SCSI ID jumper block 4-12 to 4-13  
 searching (high-speed) 8-16 to 8-17  
 SEND DIAGNOSTIC command 7-5  
 sense key 8-18  
 shock specifications 4-16  
 Small Computer System Interface  
     *See* SCSI  
 SPACE command 7-5, 8-14, 8-16  
 start/stop operation 8-5 to 8-8  
 status, SCSI 7-6  
 streaming operation 8-5 to 8-8  
 support, technical 1-1 to 1-4

## T

tapes  
     *See* data cartridges  
 technical support 1-1 to 1-4  
 temperature requirements 4-14  
 termination, SCSI 4-9 to 4-11  
 TEST UNIT READY command 7-6  
 testing 3-1 to 3-6  
 timing issues 6-2 to 6-3

## V

VERIFY command 7-6  
 vibration specifications 4-17

## W

WRITE BUFFER command 7-6  
 WRITE command 6-2, 7-6, 8-13  
 WRITE FILEMARKS command 7-6  
 write-protect switch 9-12

## X

XL tape drives  
     adding support for 6-6  
     appearance 2-2  
     capacity 2-4  
     description 2-4  
     media compatibility 9-5

Index

**Notes:**



# Reader's Comment Form

---

**EXB-8205 and EXB-8505 8mm Cartridge Tape Subsystems Integration and Optimization for Standard and eXtended-Length (XL) Configurations**  
**Part Number 510505-002**

Exabyte welcomes your comments and suggestions about this manual. To let us know how we might make our documentation more helpful, please complete and mail this form.

Rate the following on a scale of 1 to 5 (1 = very poor, 5 = outstanding):

- Is the information specific enough? \_\_\_\_\_
- Is the format easy to follow? \_\_\_\_\_
- Is the information clear and accurate? \_\_\_\_\_
- Are the drawings clear and accurate? \_\_\_\_\_

Comments:

---

---

---

---

---

---

---

---

---

---

Please provide the following information:

Today's Date: \_\_\_\_\_

Company Name: \_\_\_\_\_

Your Title: \_\_\_\_\_