

ECMA

EUROPEAN COMPUTER MANUFACTURERS ASSOCIATION

STANDARD ECMA-64

**MAGNETIC DISK FOR
DATA STORAGE DEVICES
160 000 FLUX TRANSITIONS PER TRACK
356 mm DIAMETER**

2nd Edition – September 1982

Free copies of this document are available from ECMA,
European Computer Manufacturers Association
114 Rue du Rhône – 1204 Geneva (Switzerland)

ECMA

EUROPEAN COMPUTER MANUFACTURERS ASSOCIATION

STANDARD ECMA-64

**MAGNETIC DISK FOR
DATA STORAGE DEVICES
160 000 FLUX TRANSITIONS PER TRACK
356 mm DIAMETER**

2nd Edition – September 1982

BRIEF HISTORY

In 1976 ECMA decided to undertake a new project for the standardization of individual rigid magnetic disks intended for mounting in data storage devices. The basic consideration for this decision was the wish to limit the number of types of disks required by the industry, thereby simplifying manufacturing and stock control of such disks, as well as the design and maintenance of data storage devices using them, thus ultimately reducing the price of such devices for the benefit of their end-users.

The work of ECMA TC16 resulted in three drafts which were presented to ISO/TC97/SC10 and taken over by this committee as drafts for international standards. Thanks to the co-operation of the Japanese and US experts in SC10 considerable progress was achieved. ECMA issued its standards ECMA-64, ECMA-65 and ECMA-73.

Further work in progress within ECMA and ISO led to the finalization of two more standards. In the meantime international agreement was reached on a method for the assessment of the durability of magnetic surfaces proposed by ANSI and another method for the measurement of the friction between head and disk proposed by ECMA. Both methods have been adopted by ISO/TC97/SC10. Standards ECMA-64 and ECMA-73 were revised in order to incorporate these methods and adjust the text to the wording of the new standards.

As a result ECMA has issued a set of five standards for rigid magnetic disks:

- ECMA-64, 2nd Edition: Magnetic Disk for Data Storage Devices, 160 000 Flux Transitions per Track, 356 mm Outer Diameter
- ECMA-65 : Magnetic Disk for Data Storage Devices, 107 500 Flux Transitions per Track, 266 mm and 356 mm Diameter
- ECMA-73, 2nd Edition: Magnetic Disk for Data Storage Devices, 96 000 Flux Transitions per Track, 200 mm Outer Diameter, 63,5 mm Inner Diameter
- ECMA-76 : Magnetic Disk for Data Storage Devices, 158 000 Flux Transitions per Track, 210 mm Outer Diameter, 100 mm Inner Diameter
- ECMA-77 : Magnetic Disk for Data Storage Devices, 83 000 Flux Transitions per Track, 130 mm Outer Diameter, 40 mm Inner Diameter

This 2nd Edition of ECMA-64 has been adopted by the General Assembly of ECMA on June 7, 1982.

TABLE OF CONTENTS

	<u>Page</u>
1. GENERAL	1
1.1 Scope	1
1.2 Conformance	1
2. GENERAL REQUIREMENTS	1
2.1 Operation and Storage Environment	1
2.2 Test Conditions	1
2.3 Material	1
2.4 Coefficient of Thermal Expansion	2
2.5 Surface Identification	2
3. DIMENSIONS (Fig. 1 to 3)	2
3.1 Inner Diameter	2
3.2 Outer Diameter	2
3.3 Concentricity	2
3.4 Thickness	2
3.5 Edge Chamfers	3
3.6 Clamping Area	3
3.7 Location of Magnetic Surfaces	3
4. PHYSICAL CHARACTERISTICS	3
4.1 Moment of Inertia	3
4.2 Maximum Speed	3
4.3 Runout	3
4.4 Surface Roughness	4
4.5 Cleaning of the Magnetic Surfaces	5
4.6 Durability of the Magnetic Surfaces	5
4.7 Head/Disk Gliding Requirements	6
4.8 Dynamic Coefficient of Friction between Head and Disk	6
4.9 Static Coefficient of Friction between Head and Disk	6
4.10 Discharge Path	6
5. TESTING OF MAGNETIC CHARACTERISTICS	6
5.1 General Conditions	6
5.2 Track and Recording Conditions	6
5.3 Standard Reference Surface	7
5.4 Test Head	8
5.5 Conditions for Test Head Measurements	9
5.6 Read Channel	10
5.7 Automatic Gain Controlled Amplifier	11
5.8 Track Average Amplitude (VTA)	11
5.9 Test Signals	11
5.10 DC-Erasure	11
6. SURFACE TESTS	11
6.1 Amplitude test	11
6.2 Resolution test	11

Table of Contents (cont'd)

	<u>Page</u>
6.3 Overwrite test	12
6.4 Residual noise test	12
7. TRACK QUALITY TEST	12
7.1 Positive Modulation Test	12
7.2 Negative Modulation Test	13
7.3 Missing Pulse Test	13
7.4 Extra Pulse Test	13
8. ACCEPTANCE CRITERIA FOR MAGNETIC SURFACES	13
8.1 Surface Test Criteria	13
8.2 Track Quality Criteria	13
9. DEFECTS OF THE MAGNETIC SURFACES	14
9.1 Single Defect	14
9.2 Defect Criteria	14
APPENDIX I : AIR CLEANLINESS CLASS 100	18
APPENDIX II : METHOD FOR MEASURING FRICTION BETWEEN HEAD AND DISK	20
APPENDIX III : MEASUREMENT OF THE EFFECTIVE TRACK WIDTH	22

1. GENERAL

1.1 Scope

This Standard ECMA-64 specifies the mechanical, physical and magnetic properties of a lubricated magnetic disk of 356 mm OD intended for mounting in data storage devices.

1.2 Conformance

A disk shall be in conformance with this Standard when it satisfies all requirements of this Standard.

2. GENERAL REQUIREMENTS

2.1 Operation and Storage Environment

To prevent corruption of data, the ambient stray magnetic field intensity at the surface of the disk shall not exceed 4000 A/m. When heads are present, the general ambient field must be reduced to take account of the concentrating effect of the core of the head.

NOTE:

This will typically require the limitation of the allowed ambient field to the range of 300 A/m to 2000 A/m.

2.1.1 Operation

The operating temperature of the air surrounding the disk shall be within the range 15 °C to 57 °C at a relative humidity of 8% to 80%. The wet bulb temperature shall not exceed 26 °C. The air surrounding the disk shall be of cleanliness Class 100 (Appendix I).

2.1.2 Storage

The storage temperature shall be within the range -40 °C to 65 °C at the relative humidity of 8% to 80%. The wet bulb temperature shall not exceed 30 °C. Under no circumstances shall condensation on the disk be allowed to occur.

Storage under the extreme conditions of the above range is not recommended. A temperature gradient of more than 10 °C per hour should be avoided.

2.2 Test Conditions

Unless otherwise stated, measurements shall be carried out at (23 ± 3) °C, 40% to 60% RH, after a period of acclimatization during which condensation on the disk shall not be allowed to occur. Tests requiring the use of heads shall be performed in air of cleanliness Class 100.

2.3 Material

The disk may be constructed from any suitable material so long as the dimensional, inertia and other functional requirements of this Standard are maintained.

2.4 Coefficient of Thermal Expansion

The coefficient of thermal expansion of the disk material shall be:

$$\frac{\Delta L}{L \cdot \Delta t} = \frac{1}{L} \cdot \frac{L_{57} - L_{15}}{42} \text{ per } ^\circ\text{C} = (24 \pm 1) \cdot 10^{-6} \text{ per } ^\circ\text{C}$$

The sample length L is equal to $\frac{L_{57} + L_{15}}{2}$.

2.5 Surface Identification

The direction of relative motion between head and disk shall be consistent, requiring identification of the disk surface which rotates counter-clockwise.

3. DIMENSIONS (Fig. 1 to 3)

For measurement of the radii indicated hereafter, the disk shall be mounted on a Reference Hub (Fig. 1) having a diameter, measured at $(23,0 \pm 0,5) ^\circ\text{C}$, of:

$$d_1 = 168,255 \text{ mm} \begin{array}{l} + 0,000 \text{ mm} \\ - 0,010 \text{ mm} \end{array}$$

and an outer radius

$$r_1 = 90,5 \text{ mm} \pm 0,1 \text{ mm}$$

All radii are referred to the axis of symmetry of this Reference Hub. The cylindrical surface of the Reference Hub defined by d_1 shall be contained between two co-axial cylindrical surfaces 10 μm apart.

3.1 Inner Diameter

The inner diameter of the disk, measured at $(23,0 \pm 0,5) ^\circ\text{C}$, shall be:

$$d_2 = 168,280 \text{ mm} \begin{array}{l} + 0,051 \text{ mm} \\ - 0,000 \text{ mm} \end{array}$$

The circumference of the inner edge shall be contained between two concentric circles 10 μm apart.

3.2 Outer Diameter

The outer diameter of the disk shall be:

$$d_3 = 356,26 \text{ mm} \pm 0,13 \text{ mm}$$

The circumference of the outer edge shall be contained between two concentric circles 10 μm apart.

3.3 Concentricity

The centre of the circumference of the outer edge of the disk shall be contained in a circle of diameter 50 μm concentric with the centre of the circumference of the inner edge.

3.4 Thickness

The thickness of the disk shall be:

$$e = 1,905 \text{ mm} \pm 0,025 \text{ mm}$$

3.5 Edge Chamfers

For a distance

$$l = 1,3 \text{ mm max}$$

from the edges of the disk, the disk contour shall be relieved within the extended boundaries of the disk surfaces. In order to avoid unbalance, the chamfer shall be uniform at all points on the circumference.

3.6 Clamping Area

On both sides of the disk, the clamping area shall be an area free of magnetic coating limited by the inner edge and a radius r_2 :

$$r_2 = 91,0 \text{ mm min.}$$

3.7 Location of Magnetic Surfaces

On both sides of the disk, the area of magnetic surface of the disk, over which heads may fly, shall extend from an inner radius r_3 to an outer radius r_4 :

$$r_3 = 94,0 \text{ mm max}$$

$$r_4 = 176,0 \text{ mm min.}$$

4. PHYSICAL CHARACTERISTICS

4.1 Moment of Inertia

The moment of inertia of the disk shall not exceed $8,0 \text{ g.m}^2$.

4.2 Maximum Speed

The disk shall be capable of withstanding the effect of stress at a speed of 4000 rpm.

4.3 Runout

For measuring the axial runout, and the velocity and the acceleration of axial runout, the disk shall be clamped and driven according to 4.3.1. The requirements of 4.3.2, 4.3.3 and 4.3.4 shall be met at all radii between r_3 and r_4 .

4.3.1 Test spindle requirements and clamping conditions

The disk shall be clamped on the Reference Hub by a force

$$F = 1500 \text{ N} \pm 200 \text{ N}$$

evenly applied over the whole disk on an annular surface defined by

$$r_5 = 86,5 \text{ mm}$$

$$r_6 = 88,0 \text{ mm}$$

The finish of the surface of the Reference Hub on which the disk rests shall be of class N 5 (max. arithmetical deviation $0,4 \text{ um}$).

At any speed up to the maximum speed (see 4.2) the axial runout of the Reference Hub shall not exceed $1,0 \text{ um}$.

4.3.2 Axial runout

The axial runout at any speed up to the maximum allowable speed (see 4.2) shall not exceed 0,10 mm, total indicator reading.

Moreover, every point of each surface of the disk shall be located between two planes perpendicular to the axis of the Reference Hub and distant from each other by 0,20 mm.

The two planes shall be equidistant from the clamping plane of the respective disk surface.

4.3.3 Velocity of axial runout

With the disk revolving at (3600 ± 36) rpm, the velocity of axial runout of the recording disk surfaces shall not exceed 51 mm/s. It shall be measured within the measurement band width defined by a low-pass filter with a cutoff frequency of 3,0 kHz and a high frequency roll-off of 18 dB/octave. The probe diameter shall be 1,7 mm.

4.3.4 Acceleration of axial runout

With the disk revolving at (3600 ± 36) rpm, the acceleration of axial runout shall not exceed $76,2 \text{ m/s}^2$ within the measurement band width defined by a low-pass filter with a cutoff frequency of 7,0 kHz and a high frequency roll-off of 18 dB/octave.

Further, within the pass band defined by a low frequency cutoff of 2,5 kHz and a high frequency cutoff of 5,0 kHz the acceleration shall not exceed $38,1 \text{ m/s}^2$.

The high and low frequency roll-off shall be 24 dB/octave using a non-contact capacity probe. The probe diameter shall be 1,7 mm.

4.3.5 Radial runout

The radial runout of the disk depends on the concentricity and circularity of the inner and outer edges, as well as on the clamping conditions in the device in which it is mounted. It is therefore not specified by this Standard.

4.4 Surface Roughness

4.4.1 Magnetic surfaces

The finished magnetic surfaces shall have a surface roughness less than 0,025 μm , arithmetic average, with a maximum deviation in height of 0,25 μm from the average, when measured with a 2,5 μm stylus (= with a load of 0,5 mN) and a 750 μm cutoff range. The finished magnetic surface shall have an undulation profile with a peak-to-peak amplitude of less than 0,1 μm when measured over a radial length of 4,8 mm with a 2,5 μm stylus (= with a load of 0,5 mN) having a lower cutoff point of 250 μm .

4.4.2 Clamping area

The finished surfaces of the clamping area shall have a surface roughness less than 0,8 um, arithmetic average, with a maximum deviation in height of 2,0 um from the average, when measured with a 2,5 um stylus with a load of 0,5 mN, and a 750 um cutoff range.

4.5 Cleaning of the Magnetic Surfaces

The cleaning method shall be agreed between supplier and purchaser.

4.6 Durability of the Magnetic Surfaces

The disk shall be able to withstand the effect of 10'000 head take-off and landing operations on any part of the disk surfaces between r3 and r4.

Measurements shall be taken as follows:

- 4.6.1 Condition a head (of type specified in 5.4) by 50 take-off and landing operations outside the test area defined in 4.6.2. All write operations on a track shall be preceded by DC-erasure (5.5.2) of that track.
- 4.6.2 Select two reference tracks, A and B, 12,7 mm apart. Write at 2f (see 5.9) on these two tracks and on at least 20 test tracks evenly spaced between A and B. Measure the read amplitude on each track before moving the head to the next track. The average E_{AV} of the read signals from the two reference tracks before the wear test shall be:

$$E_{AV} = \frac{E_A + E_B}{2}$$

- 4.6.3 Locate the head between reference tracks A and B so that no part of the head touches an area which would be flown over when the pole tip of the head is on either track A or track B.

Without moving the head, perform 10'000 take-off and landing operations, during which the disk shall be accelerated and decelerated between 0 and 3000 rpm. Acceleration and deceleration time between 0 and 1000 rpm shall be within 3,0 s \pm 0,5 s.

- 4.6.4 Repeat the procedure given in 4.6.2 using the same tracks. The average E'_{AV} of the read signals from the two reference tracks after the wear test shall be:

$$E'_{AV} = \frac{E'_A + E'_B}{2}$$

The head wear factor is defined as $\frac{E_{AV}}{E'_{AV}}$

- 4.6.5 Multiply the second set of readings for the test tracks by this head wear factor.

4.6.6 The durability of the magnetic surfaces shall be within this Standard when the following requirements are met:

- the head wear factor shall be $\leq 1,11$;
- for each test track the readings corrected according to 4.6.5 shall not differ by more than 10% from the reading taken in 4.6.2.

4.7 Head/Disk Gliding Requirements

The magnetic surfaces shall be free of surface defects which would cause head-to-disk contact when the head is flying at 0,35 μm minimum at radius r_3 , and proportionally increasing in flying height to 0,43 μm minimum at radius r_4 .

4.8 Dynamic Coefficient of Friction between Head and Disk

In the area between r_3 and r_4 , the average dynamic coefficient of friction μ_1 shall not exceed 0,200. Its peak-to-peak variation $\Delta\mu_1$ shall not exceed 0,035.

The method of measurement is described in Appendix III.

4.9 Static Coefficient of Friction between Head and Disk

In the area between r_3 and r_4 , the static coefficient of friction μ_2 when measured after the head has been in stationary contact with the disk under conditions of 2.1 for at least 48 hours shall be not greater than 1,0.

The method of measurement is described in Appendix III.

4.10 Discharge Path

The disk shall allow flow of electrical charges from the magnetic surface to the clamping area.

5. TESTING OF MAGNETIC CHARACTERISTICS

5.1 General Conditions

5.1.1 Rotational speed

The rotational speed shall be (3600 ± 72) rpm in any test period. Rotation shall be counterclockwise when viewed from above.

5.1.2 Ambient stray magnetic field

The intensity of the ambient stray magnetic field shall not exceed 800 A/m.

5.2 Track and Recording Conditions

5.2.1 Width of tracks

For testing purposes, the effective track width shall be:

$$40 \mu\text{m} \pm 4 \mu\text{m}$$

A suggested method of measuring the effective track width is described in Appendix II.

5.2.2 Track spacing

For testing purposes, the track centreline spacing shall be such that the whole area defined in 5.2.3 will be tested.

5.2.3 Tested area

All functional tests and all track quality tests shall be performed between an innermost track having its centreline at a radius $r7$ and an outermost track having its centreline at a radius $r8$.

$$r7 = 101,25 \text{ mm}$$

$$r8 = 166,46 \text{ mm}$$

5.2.4 Location of the line of access

The line of access shall be radial within 0,25 mm.

5.2.5 Recording offset angle

At the instant of writing or reading a magnetic transition, the angle between the transition and the line of access may be 60' maximum.

5.3 Standard Reference Surface

5.3.1 Characteristics

The Standard Reference Surface shall be characterized at the innermost and outermost tracks (radii $r7$ and $r8$), using a test head specified in 5.4 having its calibration factors (see 5.4.9) equal to 1.

When recorded at 1f (see 5.9) using this test head, the track average amplitude (see 5.8) shall be:

$$1,35 \text{ mV at radius } r7$$

$$2,65 \text{ mV at radius } r8$$

When recorded at 2f (see 5.9), using a test head, the track average amplitude shall be:

$$1,00 \text{ mV at radius } r7$$

$$2,30 \text{ mV at radius } r8$$

When measured at radius $r8$ using this test head, the overwrite ratio (see 6.3) shall be 0,04.

5.3.2 Secondary Standard Reference Surface

This is a surface the output of which shall be related to the Standard Reference Surface via calibration factors C_{D1} (for 1f) and C_{D2} (for 2f) and an overwrite calibration factor C_{D0} .

The amplitude calibration factors C_D are defined by:

$$C_D = \frac{\text{Standard Reference Surface Output}}{\text{Secondary Standard Reference Surface Output}}$$

For both C_{D1} and C_{D2} the measurements shall be made at radii $r7$ and $r8$.

The overwrite calibration factor C_{DO} is defined by:

$$C_{DO} = \frac{\text{Overwrite ratio of Standard Reference Surface}}{\text{Overwrite ratio of Sec. Stand. Ref. Surface}}$$

The measurements shall be made at radius $r8$.

To qualify as a Secondary Standard Reference Surface, the calibration factors C_D and C_{DO} for such disks shall satisfy $0,90 \leq C \leq 1,10$ at the measured radii for both frequencies.

NOTE:

It is expected that a Standard Reference Surface for Signal Amplitude will be established by the Physikalisch-Technische Bundesanstalt (PTB) Lab. 5.11, Braunschweig, Germany. Secondary Signal Amplitude Reference Surfaces or a calibration service would then also be made available.

5.4 Test Head

The test head shall be calibrated to the Standard Reference Surface, and used for amplitude measurement and testing of the magnetic surfaces.

NOTE:

A suitable test head is a 3350-type test head without amplifier, selected to conform to the requirements listed hereunder.

5.4.1 Gap width

The width of the recording gap (measured optically) shall be:

$$37 \text{ um} \pm 4 \text{ um}$$

5.4.2 Gap length

The length of the recording gap shall be $1,4 \text{ um} \pm 0,2 \text{ um}$.

5.4.3 Gap offset angle

The angle between the recording gap in the ferrite core and the relevant mounting surface of the head may be 60° maximum.

5.4.4 Flying height

When flying over the innermost track, the test head shall have a flying height at the gap of $0,48 \text{ um} \pm 0,05 \text{ um}$.

5.4.5 Inductance

The total head inductance shall be $8,5 \text{ uH} \pm 0,5 \text{ uH}$ measured in air at 1 MHz. Each leg shall have an inductance of $2,5 \text{ uH} \pm 0,3 \text{ uH}$.

5.4.6 Resonant frequency

The resonant frequency of the total read/write coil of the head shall be such as to meet the requirements of 5.6.1.

5.4.7 Resolution

The test head shall have a resolution of $(74 \pm 3)\%$ at radius r7 and $(87 \pm 5)\%$ at radius r8. Resolution is defined as:

$$\frac{2F \text{ Amplitude}}{1F \text{ Amplitude}} \cdot 100\%$$

5.4.8 Head loading force

The net head loading force shall be such as to achieve the flying height (5.4.4) and shall be:

$$0,093 \text{ N} \pm 0,010 \text{ N.}$$

5.4.9 Calibration factors

The amplitude calibration factors of the test head C_{H1} at 1f and C_{H2} at 2f, and its overwrite calibration factor C_{HO} shall satisfy $0,90 \leq C_H \leq 1,10$.

C_H is defined by:

$$C_H = \frac{\text{Standard Reference Surface Output}}{\text{Actual head voltage measured}}$$

when measured on a Standard Reference Surface, or by

$$C_H = \frac{\text{Standard Reference Surface Output}}{(\text{Actual head voltage measured}) \cdot C_D}$$

when measured on a Secondary Standard Reference Surface.

The overwrite calibration factor is defined by:

$$C_{HO} = \frac{\text{Standard Reference Surface Overwrite Ratio}}{\text{Actual measured overwrite Ratio}}$$

when measured on a Standard Reference Surface, or by

$$C_{HO} = \frac{\text{Standard Reference Surface Overwrite Ratio}}{(\text{Actual measured Overwrite Ratio}) \cdot C_{DO}}$$

when measured on a Secondary Standard Reference Surface.

5.5 Conditions for Test Head Measurements

5.5.1 Write current

The 1f write current shall conform to Fig. 4. The current amplitude measured at the head termination connector shall have two values:

Radii mm	Write current ($I_{W+} + I_{W-}$) Tolerance: $\pm 1\%$ mA
166,46 to 133,85	80
133,85 to 101,25	70

The differences between the positive and negative amplitudes of the quiescent write current $|I_{W+} - I_{W-}|$ shall be less than 2 mA.

$$T_R = 55 \text{ ns} \pm 5 \text{ ns}$$

$$T_F = 55 \text{ ns} \pm 5 \text{ ns}$$

$$\text{Overshoot: } (2,5 \pm 0,5)\% \text{ of } I_W = (I_{W+} + I_{W-})$$

Two consecutive half periods τ_1, τ_2 shall not differ from $\frac{\tau_1 + \tau_2}{2}$ by more than 1%.

5.5.2 DC-erase current

The DC-erase current supplied to one of the two read/write coils when DC-erase is specified shall be:

Radii mm	DC-erase current Tolerance: $\pm 1\%$ mA
166,46 to 133,85	40
133,85 to 101,25	35

5.6 Read Channel

5.6.1 Input impedance

The differential input impedance of the read channel shall be $750 \text{ Ohm} \pm 37 \text{ Ohm}$ in parallel with $12 \text{ pF} \pm 2,5 \text{ pF}$, including the amplifier input impedance and all other distributed and lumped impedance measured at the input connections of the read amplifier.

5.6.2 Frequency and phase characteristics

The frequency response shall be flat within $\pm 0,20 \text{ dB}$ from $0,15 \text{ MHz}$ to $9,50 \text{ MHz}$ (approx. $0,06 \text{ f}$ to 4 f).

The -3 dB roll-off point shall be at $14,40 \text{ MHz}$ (approx. 6 f).

The attenuation above $14,40 \text{ MHz}$ shall not be less than that given by a line drawn through zero dB at $14,40 \text{ MHz}$ with a slope of -18 dB/octave .

The phase shift shall be linear within $\pm 5^\circ$ between 0,15 MHz and 9,50 MHz (approx. $0,06 f$ and $4 f$).

5.6.3 Transfer characteristics

For inputs between 0,2 mV peak-to-peak and 6 mV peak-to-peak the transfer characteristic of the read channel shall be linear within $\pm 3\%$ or 50 uV, whichever is larger.

5.7 Automatic Gain Controlled Amplifier

The AGC-amplifier shall produce an output voltage V_{AGC} constant within $\pm 1\%$ for input voltages from $V_{inmin} = 0,2$ mV peak-to-peak to $V_{inmax} = 6$ mV peak-to-peak (see Fig. 5).

Its response time shall be 10 us. All frequencies below 10 kHz shall be attenuated at a rate of 6 dB/octave.

5.8 Track Average Amplitude (VTA)

The track average amplitude (VTA) is the average of the peak-to-peak values of the signals over one revolution of the disk, measured at the output of the Test Head when electrically loaded as described in 5.6.

5.9 Test Signals

The recording frequencies specified as $1f$ and $2f$ shall be:

$$1f = (4792 \pm 4,792) \cdot 10^3 \text{ transitions/s}$$

$$2f = (9584 \pm 9,584) \cdot 10^3 \text{ transitions/s}$$

5.10 DC-Erasure

Unless otherwise specified all write operations shall be preceded by a DC-erase operation.

6. SURFACE TESTS

6.1 Amplitude test

Procedure

Write on any part of the surface at $2f$ read back and measure the V_{TA} .

Result

The upper limit for the track average amplitude of the corrected test head output shall be 1,3 mV peak-to-peak at radius r_7 and shall increase linearly to a value of 3,0 mV peak-to-peak at radius r_8 . The lower limit for the track average amplitude shall be 0,7 mV peak-to-peak at radius r_7 and shall increase linearly to a value of 1,6 mV peak-to-peak at radius r_8 (see Fig. 6).

6.2 Resolution test

Procedure

On any part of the magnetic surface write at $1f$, read back and measure the V_{TA} . Then DC-erase, write at the same position at

2f, read back and again, measure the V_{TA} . The value of the measured V_{TA} shall be corrected by the appropriate head calibration factor (5.4.9).

Result

In all cases the ratio:

$$\frac{\text{Average Track Amplitude of 2f-signal}}{\text{Average Track Amplitude of 1f-signal}}$$

shall be $0,80 \pm 0,15$.

6.3 Overwrite test

Procedure

Write at 1f at radius r8 and measure the average amplitude of the 1f-signal with a frequency-selective voltmeter. Without DC-erase, overwrite once at 2f, measure the average amplitude of the residual 1f-signal with the frequency-selective voltmeter.

Result

The ratio:

$$\frac{C_{HO} \cdot (\text{Average Amplitude of 1f-signal after overwrite})}{\text{Average Amplitude of 1f-signal before overwrite}}$$

shall be less than 0,05.

6.4 Residual noise test

Procedure

DC-erase a 5-track band with the central track at radius r7. Write at radius r7 at 2f, read back and measure the RMS value (V_{RMS}), using a true RMS-voltmeter with a bandwidth of 10 MHz at the -6 dB point.

Then DC-erase once, read back and measure the RMS value (V_{DCRMS}), unload the head and measure the RMS value of the noise due to all other noise sources (V_{NRMS}). V_{NRMS} shall not exceed $0,025 V_{RMS}$.

Result

The ratio:

$$\frac{\sqrt{V_{DCRMS}^2 - V_{NRMS}^2}}{V_{RMS}}$$

shall be less than 0,05.

7. TRACK QUALITY TEST

7.1 Positive Modulation Test

Procedure

Write on any track at 2f, read back and measure the V_{TA} . With a delay of $t_d = 1,55 \text{ us} \pm 0,15 \text{ us}$ after detecting a read

pulse exceeding 125% of $0,5 V_{TA}$, count all further such read pulses during a time period $t_{pm} = 3,10 \text{ us} \pm 0,15 \text{ us}$ (see Fig. 7).

Result

Positive amplitude modulation occurs if the number of the counted pulses exceeds 24.

7.2 Negative Modulation Test

Procedure

Write on any track at 2f, read back and measure the V_{TA} . With a delay of $t_d = 1,55 \text{ us} \pm 0,15 \text{ us}$ after detecting a read pulse not reaching 75% of $0,5 V_{TA}$, count all further such read pulses during a time period $t_{nm} = 60 \text{ us} \pm 1 \text{ us}$ (see Fig. 7).

Result

Negative amplitude modulation occurs if the number of counted pulses exceeds 384.

7.3 Missing Pulse Test

Procedure

Write on each track at 2f and read back using the AGC-amplifier.

Result

A missing pulse shall be any read pulse whose amplitude is less than 55% of the AGC output voltage (V_{AGC}).

7.4 Extra Pulse Test

Procedure

Write on each track at 2f, read back and measure the V_{TA} . Then DC-erase once and read back over one revolution.

Result

An extra pulse shall be any spurious read pulse exceeding 35% of $0,5 V_{TA}$.

8. ACCEPTANCE CRITERIA FOR MAGNETIC SURFACES

8.1 Surface Test Criteria

The disk shall meet the requirements of all tests specified in 6.

8.2 Track Quality Criteria

Modulation criteria

Positive or negative amplitude modulation as defined in 7.1 and 7.2 shall not occur in any track.

9. DEFECTS OF THE MAGNETIC SURFACES

9.1 Single Defect

A single defect is the occurrence of a missing pulse (7.3) or of an extra pulse (7.4).

9.2 Defect Criteria

The defect criteria are subject to agreement between supplier and purchaser.

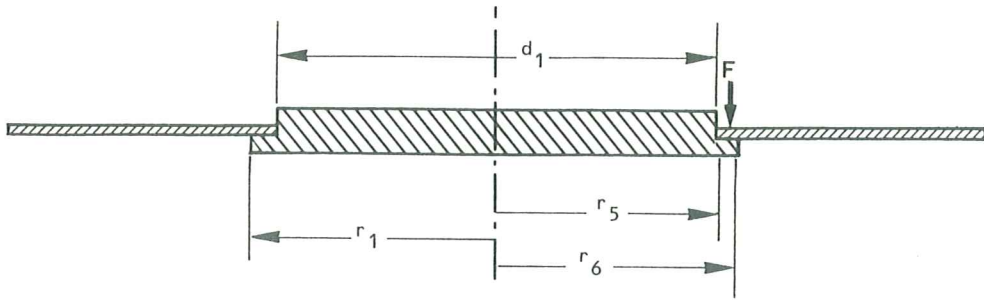

Fig. 1

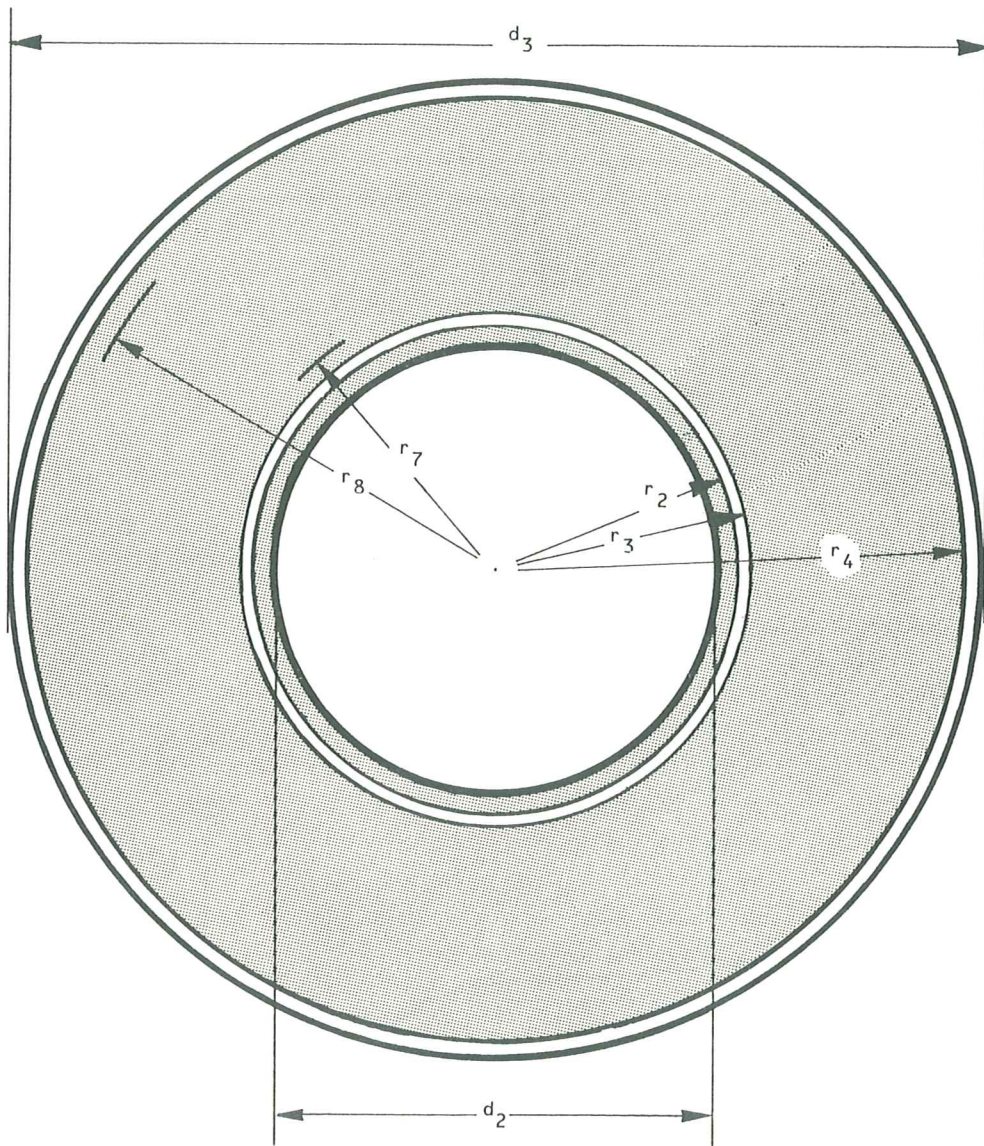

Fig. 2

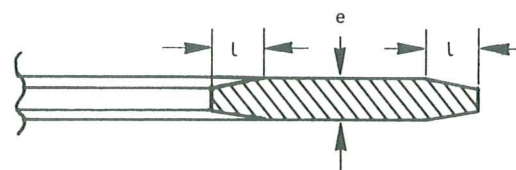

Fig. 3

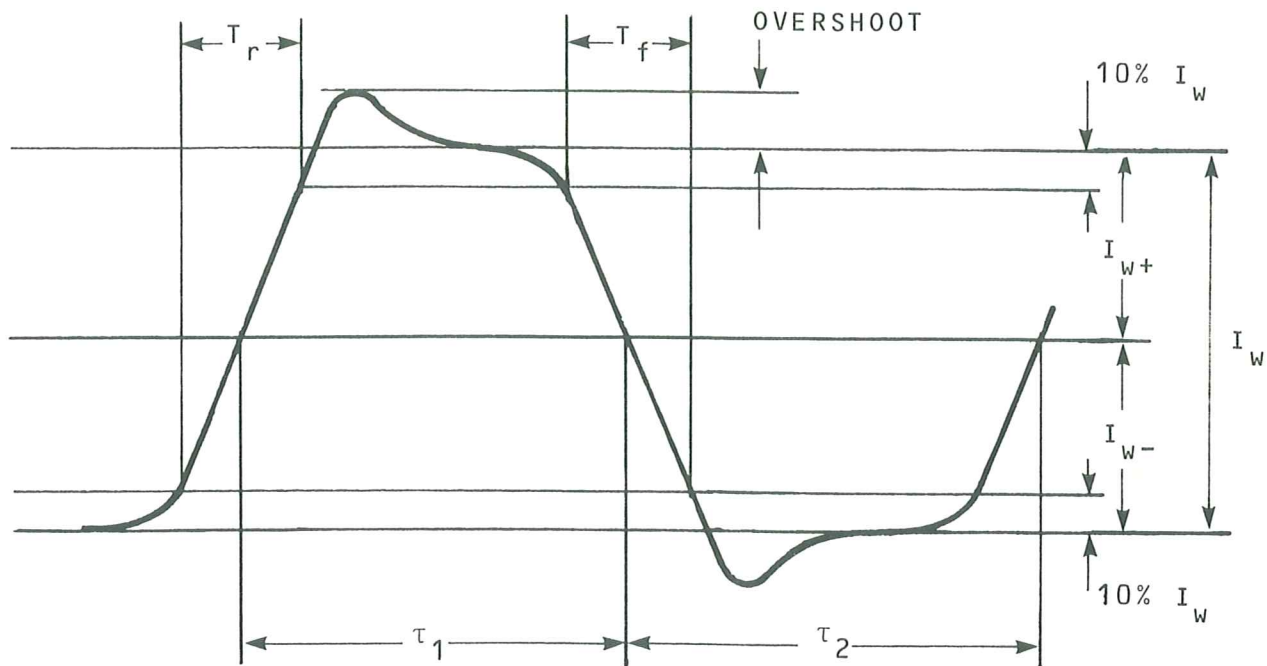

Fig. 4

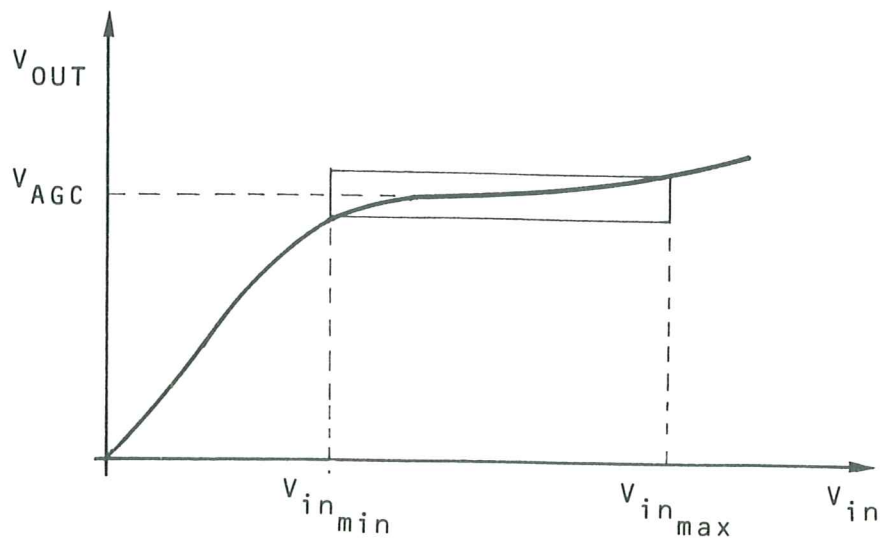

Fig. 5

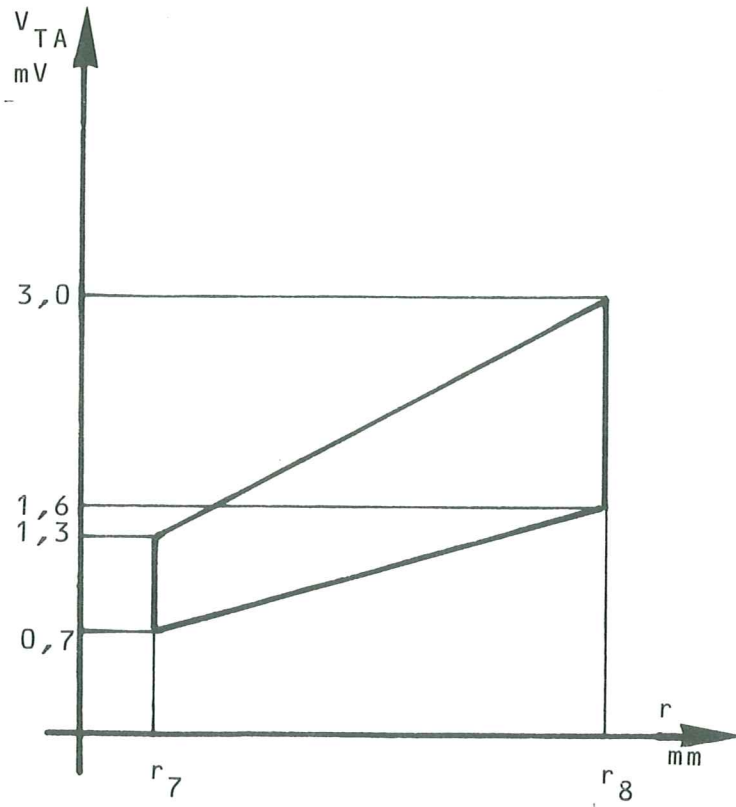

Fig. 6

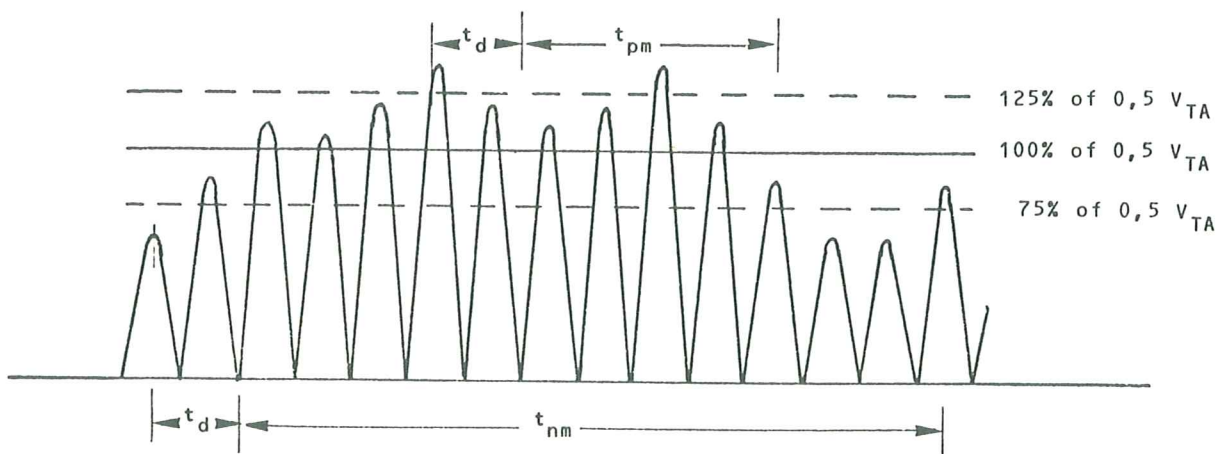

Fig. 7

APPENDIX I

AIR CLEANLINESS CLASS 100

Classification of air cleanliness is based on particle count with a maximum allowable number of specified minimum sized particles per unit volume and on statistical average particle size distribution.

Definition of Class 100*

The particle count shall not exceed a total of 3,5 particles of size 0,5 μm or larger per liter.

The statistical average particle size distribution is represented below. Class 100 means that 3,5 particles per liter of a size 0,5 μm are allowed, but only 0,035 particles per liter of a size 4,0 μm .

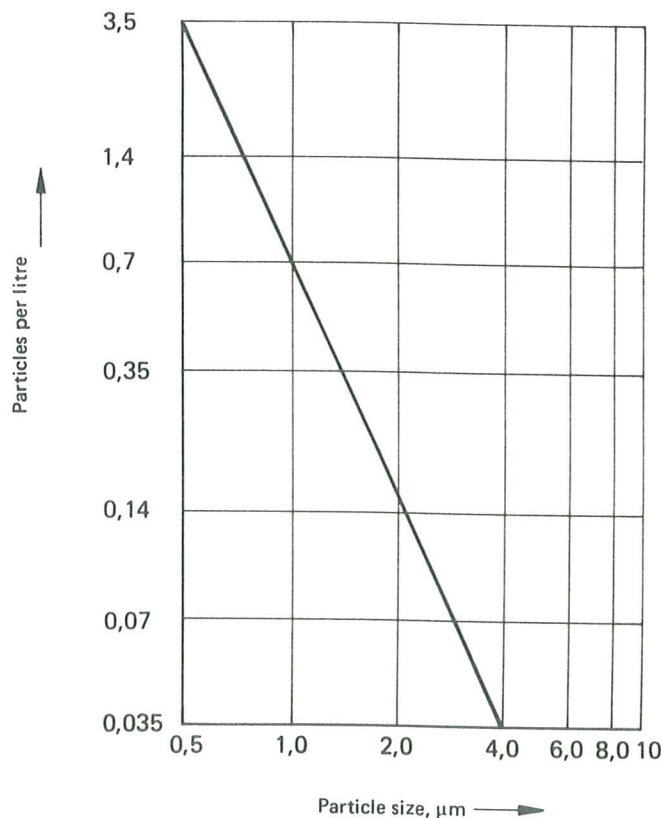

*) *USA Federal Standard Fed.Std. No. 209 B, available from the general Services Administration, Specification Activity, Printed Materials Supply Division, Building 197, Naval Weapons Plant, Washington, D.C. 20407, USA.*

It should be recognized that single sample distribution may deviate from this curve because of local or temporary conditions. Counts below 0,35 particles per liter are unreliable except when a large number of samplings is taken.

Test Method **)

For particles in the 0,5 to 5,0 μm size range, equipment employing light-scattering principles shall be used. The air in the controlled environment is sampled at a known flow rate. Particles contained in the sampled air are passed through an illuminated sensing zone in the optical chamber of the instrument. Light scattered by individual particles is received by a photodetector which converts the light pulses into electrical current pulses. An electronic system relates the pulse height to particle size and counts the pulses such that the number of particles in relation to particle size is registered or displayed.

***) American Society for Testing and Materials,
Standard ASTM F 50, 1916 Race St.,
Philadelphia, PA 19103, USA*

APPENDIX II

METHOD FOR MEASURING FRICTION BETWEEN HEAD AND DISK

II.1 Measurements shall be made in the environment specified in 2.2. The disk to be tested shall be clean and free of dust, contamination, and fingerprints.

II.2 A magnetic head of the type described in 5.4 shall be modified in the following way:

As shown in Fig. II.1 and II.2, the head mounting shall be attached to the actuator by a low-friction pivot allowing rotation about the vertical axis. The sideways force acting on the head shall be measured by a load cell. This load cell shall act either directly against the head mounting (Fig. II.1) or against an elbow extension (Fig. II.2).

II.3 A spindle drive shall be installed which allows slow rotation of up to 1 rpm, e.g. by a regulated motor and reduction gear.

II.4 The disk to be tested shall be mounted horizontally on the spindle and the head assembly shall be gently loaded. The head-to-disk geometry shall ensure that the conditions specified in 5.2.4 and 5.2.5 apply. The head loading force shall be as specified in 5.4.8.

II.5 The spindle shall be rotated and the force shall be measured by the load cell. It is preferable to record the adhesion force as a function of time corresponding to the rotation of the disk. The speed of rotation shall be adjusted such that the relative speed between head and disk is between 1 mm/s and 5 mm/s.

II.6 The coefficients of friction, μ_1 and μ_2 , between head and disk (shown in Fig. II.3 in function of the time t) are:

$$\mu = \frac{F}{p} \cdot \frac{\ell_L}{\ell_H}$$

where:

F = measured force at load cell

p = head loading force

ℓ_L , ℓ_H = lengths of the levers shown in Fig. II.1 and II.2.

II.7 Before a disk is tested the head assembly shall be cleaned with any suitable cleaner to ensure that no lubricant is transferred from disk to disk or is left on the head thereby influencing subsequent friction measurements.

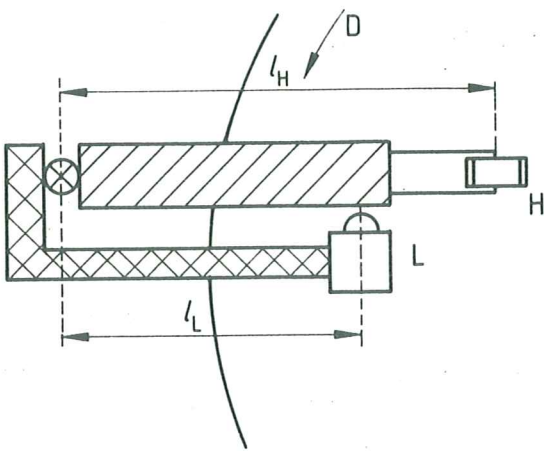

Fig. II.1

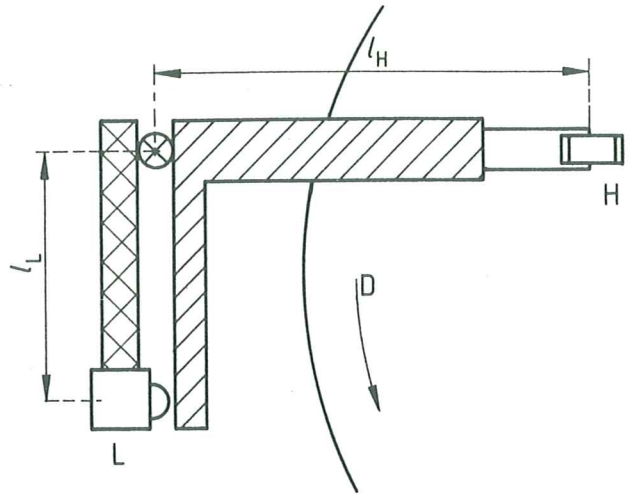





Fig. II.2

-  = parts firmly attached to actuator
-  = pivot bearing
-  = pivoting head mount
- H = magnetic head
- L = load cell
- D = magnetic disk

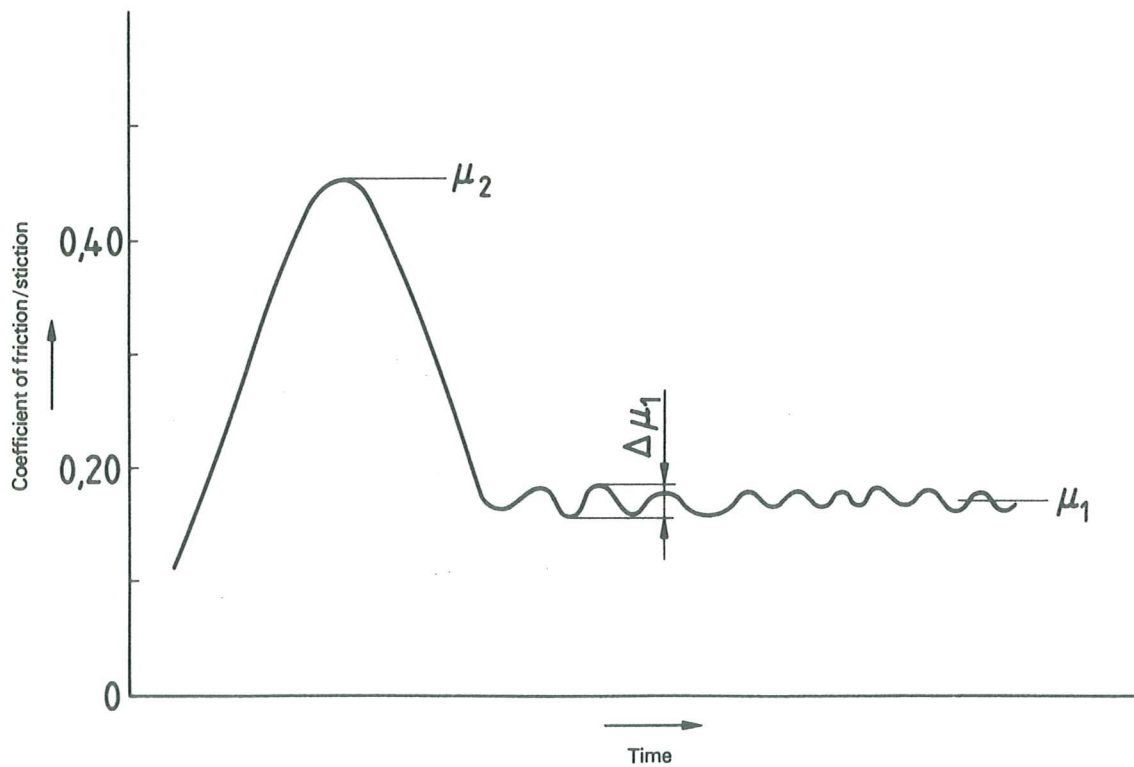

Fig. II.3

APPENDIX III

MEASUREMENT OF THE EFFECTIVE TRACK WIDTH

DC-erase a 7-track wide band with the central track at radius r7 and write with 1f frequency at radius r7 using the head to be tested, then read back.

The read back signal amplitude in this position is called 100%. Then move the head along its line of access over the disk in increments not greater than 0,005 mm to the left or to the right of radius r7 until the read back signal becomes zero. Determine the read back signal amplitude at each incremental move and plot the relative amplitude (Y axis) versus the displacement (X axis).

See diagram for reading the effective track width.

The fringing of the curve at the low level end of the curve shall be ignored for determining the track width.

