

VAX-11/730 System Installation Guide

VAX-11/730 System Installation Guide

Prepared by Educational Services
of
Digital Equipment Corporation

Copyright © 1983 by Digital Equipment Corporation
All Rights Reserved

The information in this document is subject to change without notice and should not be construed as a commitment by Digital Equipment Corporation. Digital Equipment Corporation assumes no responsibility for any errors that may appear in this document.

Printed in U.S.A.

The manuscript for this book was created on a DIGITAL Word Processing System and, via a translation program, was automatically typeset on DIGITAL DECset Integrated Publishing System. Book production was done by Educational Services Development and Publishing in Nashua, NH.

The following are trademarks of Digital Equipment Corporation:

digital ™	DECtape	Rainbow
DATATRIEVE	DECUS	RSTS
DEC	DECwriter	RSX
DECmate	DIBOL	UNIBUS
DECnet	MASSBUS	VAX
DECset	PDP	VMS
DECsystem-10	P/OS	VT
DECSYSTEM-20	Professional	Work Processor

CONTENTS

	Page
CHAPTER 1 INTRODUCTION	
1.1 MANUAL SCOPE	1-1
1.2 MANUAL CONVENTIONS	1-1
1.3 RELATED DOCUMENTATION	1-4
CHAPTER 2 SYSTEM CABINET PREPARATION	
2.1 GENERAL	2-1
2.2 BOXED EQUIPMENT	2-1
2.3 MOVING CONSTRAINTS	2-1
2.4 SHIPMENT INVENTORY	2-1
2.5 UNPACKING BOXES	2-2
2.6 UNPACKING THE SYSTEM CABINET	2-2
2.7 UNPACKING OTHER CABINETS	2-3
CHAPTER 3 VAX-11/730 SYSTEMS 1 AND 2 HARDWARE INSTALLATION	
3.1 GENERAL	3-1
3.2 VAX-11/730 CABINET CONFIGURATION GUIDELINES	3-1
3.3 VAX-11/730 SYSTEMS 1 AND 2 CABINET INSTALLATION	3-1
3.3.1 System Cabinet Installation	3-1
3.3.2 UNIBUS Expander Cabinet Installation	3-2
3.4 VAX-11/730 SYSTEMS 1 AND 2 DEVICE PREPARATION	3-8
3.4.1 CPU Mounting Box (BA11-Z)	3-8
3.4.2 Cabling Check	3-8
3.4.3 RL02 Disk Drive	3-8
3.4.4 R80 Disk Drive	3-11
3.4.5 Console Terminal	3-15
3.4.6 WCS Module (Switch Settings)	3-15
3.4.7 DMF32 Module (Switch Settings)	3-18
3.4.8 DMF32 I/O Panel (Switch Settings)	3-20
3.5 VAX-11/730 SYSTEMS 1 AND 2 POWER-UP PROCEDURE	3-22
3.6 RL02 SETUP	3-24
CHAPTER 4 VAX-11/730 SBB HARDWARE INSTALLATION	
4.1 GENERAL	4-1
4.2 VAX-11/730 SBB SYSTEM CONFIGURATION GUIDELINES	4-1
4.3 VAX-11/730 SBB CABINET INSTALLATION	4-1
4.3.1 System Cabinet Installation	4-2
4.3.2 UNIBUS Expander Cabinet Installation	4-3
4.4 DRIVE DEVICE CABINET PREPARATION	4-13
4.5 CONSOLE TERMINAL	4-14

4.6	VAX-11/730 SBB DEVICE PREPARATION	4-14
4.6.1	CPU Mounting Box (BA11-AS/AT)	4-14
4.6.2	Cabling Check	4-14
4.6.3	Console Terminal	4-18
4.6.4	Drive Devices	4-18
4.6.5	WCS Module (Switch Settings)	4-18
4.7	VAX-11/730 SBB SYSTEM POWER-UP PROCEDURE	4-20

CHAPTER 5 VAX-11/730-ZA OEM BOX INSTALLATION

5.1	GENERAL	5-1
5.2	BOXED EQUIPMENT	5-1
5.3	UNPACKING THE VAX-11/730-ZA OEM BOX	5-1
5.4	HARDWARE INSTALLATION	5-1
5.4.1	Cable Retractor Tray Assembly Installation	5-2
5.4.2	Cabinet Slide Assembly Installation	5-3
5.4.3	BA11-Z Mounting Box Installation	5-5
5.4.4	Cable Carrier Assembly Installation	5-5

CHAPTER 6 VAX-11/730 SYSTEMS 1 AND 2 OPTION INSTALLATION AND CABLE ROUTING

6.1	GENERAL	6-1
6.2	MODULE INSTALLATION	6-1
6.3	I/O PANEL INSTALLATION	6-2
6.3.1	DMF32 I/O Panel Installation	6-2
6.3.2	UNIBUS Expansion I/O Panel Installation	6-3
6.3.3	TU80 I/O Panel Installation	6-4
6.4	INTERNAL CABLE ROUTING	6-4
6.4.1	WCS Cable Routing	6-6
6.4.2	DMF32 Cable Routing	6-9
6.4.3	UNIBUS Cable Routing	6-12
6.4.4	TU80 Cable Routing	6-16
6.5	EXTERNAL CABLE ROUTING	6-18

CHAPTER 7 VAX-11/730 SBB OPTION INSTALLATION AND CABLE ROUTING

7.1	GENERAL	7-1
7.2	CONFIGURATION GUIDELINES	7-1
7.3	OPTION MODULE INSTALLATION	7-2
7.4	OPTION I/O PANEL INSTALLATION	7-2
7.5	OPTION CABLING	7-4
7.6	CABLING FROM THE SYSTEM	7-6

CHAPTER 8 ACCEPTANCE TESTING

8.1	GENERAL	8-1
8.2	ACCEPTANCE TESTING WITH CUSTOMER RUNNABLE DIAGNOSTICS (CRD)	8-2

8.3	ACCEPTANCE TESTING WITH THE DIAGNOSTIC SYSTEM COMMAND LANGUAGE	8-4
8.3.1	Microdiagnostics	8-4
8.3.2	Loading the Console Microcode	8-6
8.3.3	Macrodiagnostics	8-6
8.4	ACCEPTANCE TESTING THE VAX-11/730 SBB SYSTEM WITHOUT AN RA60 DISK DRIVE	8-7
8.5	EXECUTING THE USER ENVIRONMENTAL TEST PACKAGE (UETP)	8-10

FIGURES

Figure No.	Title	Page
1-1	VAX-11/730 System 1 Cabinet	1-2
1-2	VAX-11/730 System 2 Cabinet	1-2
1-3	VAX-11/730 SBB Cabinet	1-3
2-1	Unpacking the VAX-11/730 System Cabinet	2-2
2-2	Attaching the Ramps and Removing the Shipping Brackets from the VAX-11/730	2-3
3-1	Leveler Feet Adjustment	3-2
3-2	System and Expander Cabinet Rear Door Removal and Replacement	3-3
3-3	Cabinet End Panel Removal	3-4
3-4	Cabinet Joiner Panel Removal	3-4
3-5	Cable Trough/Stabilizer Bar Kit	3-5
3-6	Leveler Feet Assembly and Installation	3-5
3-7	Joining the System and Expander Cabinets (Rear View)	3-6
3-8	Bolting the Joined Cabinets Together	3-6
3-9	Stabilizer Bar Installation	3-7
3-10	CPU Box Shipping Restraints	3-9
3-11	CPU Box Service Interlock (Tether)	3-10
3-12	R80 Service Interlock	3-12
3-13	R80 Logic Chassis Exposed (Logic Access Cover Raised)	3-13
3-14	R80 Head Disk Assembly (HDA) Exposed (Logic Chassis Assembly Raised)	3-14
3-15	R80 HDA Shipping Restraints	3-15
3-16	Module Access Cover Removal	3-16
3-17	Module Use Chart	3-17
3-18	Switchpack and Connector Locations on the WCS Module	3-17
3-19	Switchpack and Connector Locations on the DMF32 Module	3-19
3-20	Switchpack Location on the DMF32 I/O Panel	3-21
3-21	Rear View of the System Cabinet Showing RL02, R80, and 874 Voltage Labels and Circuit Breakers	3-22
3-22	CPU Box Circuit Breaker and Voltage Select Switch Locations	3-23
3-23	Rear of the System Cabinet Showing the RL02 Shipping Restraint	3-25
3-24	RL02 Head Disk Assembly Exposed	3-26
4-1	Leveler Feet Adjustment	4-2
4-2	System and Expander Cabinet Front Door Removal and Replacement	4-4
4-3	System and Expander Cabinet Rear Door Removal and Replacement	4-5
4-4	Cabinet End Panel Removal	4-6
4-5	Cabinet Joiner Panel Removal	4-6
4-6	Cable Trough/Stabilizer Bar Kit	4-7
4-7	Leveler Feet Assembly and Installation	4-7
4-8	Shielding Insert Removal from the System Cabinet	4-8

4-9	Shielding Insert Removal from the Expander Cabinet	4-9
4-10	Knockout Removal from the Shielding Insert	4-10
4-11	Mounting the Cable Trough to the Shielding Insert	4-11
4-12	Joining the System and Expander Cabinets	4-11
4-13	Bolting the Joined Cabinets Together	4-12
4-14	Stabilizer Bar Installation (Rear View)	4-13
4-15	CPU Mounting Box Shipping Restraint	4-15
4-16	CPU Mounting Box Release Latch	4-16
4-17	Top Cover Assembly Removal	4-17
4-18	Module Location Chart	4-18
4-19	Switchpack and Connector Locations on the WCS Module	4-19
4-20	CPU Mounting Box Slide Locks	4-20
4-21	Rear View of System Cabinet Showing Device Voltage Labels and Circuit Breaker Locations	4-21
5-1	Unpacking the VAX-11/730-ZA OEM Box	5-2
5-2	VAX-11/730-ZA OEM Box Mounted in a 19-Inch Cabinet	5-3
5-3	Mounting the Cabinet Retractor Tray and Cabinet Slides to the Cabinet	5-4
5-4	Mounting the BA11-Z Mounting Box to the Cabinet Slides	5-6
5-5	Mounting the Carrier/Box Bracket to the Rear of the BA11-Z Mounting Box	5-7
6-1	Removal of Blank Panels from the System Bulkhead	6-2
6-2	Installation of the DMF32 I/O Panel into the System Bulkhead	6-3
6-3	Installation of the UNIBUS Expansion Cable I/O Panel into the System I/O Panel	6-3
6-4	Installation of the TU80 I/O Panel into the System I/O Panel	6-4
6-5	Catch Pan Assembly with Cables Routed	6-5
6-6	CPU Cable Retractor Tray Assembly with Cables Routed	6-6
6-7	WCS Cables Routed Through the CPU Cable Retractor Tray Assembly and Connected to the System I/O Panel	6-7
6-8	Side View of the CPU Cable Retractor Tray Assembly with Cable Routed	6-8
6-9	Catch Pan Assembly Removal from the CPU Mounting Box	6-9
6-10	DMF32 Cables Routed Through the Catch Pan Assembly	6-10
6-11	DMF32 Cables Routed Through the CPU Cable Retractor Tray Assembly and Connected to the DMF32 I/O Panel	6-11
6-12	Module Cage Assembly with Cable Folding Instructions	6-13
6-13	UNIBUS Expansion Cables Routed Through the Catch Pan Assembly	6-14
6-14	UNIBUS Expansion Cables Routed Through the CPU Cable Retractor Tray Assembly and Connected to the UNIBUS I/O Panel	6-15
6-15	TU80 Cables Routed Through the Catch Pan Assembly	6-16
6-16	TU80 Cables Routed Through the CPU Cable Retractor Tray Assembly and Connected to the TU80 I/O Panel	6-17
6-17	Cable Strain Reliefs for Exterior Cabling	6-18
7-1	Device Bulkhead Location on the VAX-11/730 SBB System I/O Bulkhead	7-3
7-2	Cable Routing from the CPU Mounting Box	7-4
7-3	Cable Routing Through the System Cabinet with the CPU Mounting Box Extended	7-5
7-4	System Cabinet Cable Clamp Replacement with the CPU Mounting Box Set into the Cabinet	7-5

TABLES

Table No.	Title	Page
1-1	Documents Related to the VAX-11/730 System	1-4
3-1	The WCS Module E47 Switchpack Switch Settings and Corresponding Console Baud Rates	3-18
3-2	DMF32 Module Switchpack E77 Settings for Interrupt Priority Levels BR5 and BR6	3-19
3-3	DMF32 Module Switchpack E75 Settings for Beginning UNIBUS Address FE0E0	3-20
3-4	Switch Settings of Switchpacks 1 and 2 for Controlling Modem Bits of Asynchronous Lines 0 and 1	3-20
3-5	Switch Settings of Switchpack 3 for Controlling Modem Bits of the Synchronous Line	3-21
3-6	Switch Settings of Switchpack 3 for the Devices on the DMF32	3-21
4-1	The WCS Module E47 Switchpack Switch Settings and Corresponding Console Baud Rates	4-19
8-1	Microdiagnostics Available for the VAX-11/730	8-4
8-2	Macrodiagnostics Available for the VAX-11/730	8-6

EXAMPLES

Example No.	Title	Page
8-1	Successful CRD Program Run on a Basic RL02/R80 Configured System	8-3
8-2	Successful CRD Program Run on a Basic RA60/RA80 Configured System	8-3
8-3	Console Printout of Microdiagnostics Loading	8-5
8-4	Successful Loading and Completion of the Microdiagnostics on a Basic R80/RL02 Configured System	8-5

CHAPTER 1 INTRODUCTION

1.1 MANUAL SCOPE

This guide provides the procedures for installing and accepting the VAX-11/730 systems 1 and 2 and the VAX-11/730 SBB (System Building Block). These procedures have been developed for use by DIGITAL field service engineers. This guide lists the steps that must be taken, following equipment delivery, in preparation for final acceptance by the customer.

The unpacking and inventory procedures are designed to ensure that the shipped VAX-11/730 system is the one actually ordered by the customer; and that the hardware, software, and documentation for that system are present, accounted for, and at the current revision level.

NOTE

The entire VAX-11/730 system and appropriate documentation should be present before installation starts. Any discrepancies must be noted and dealt with.

1.2 MANUAL CONVENTIONS

This document uses the following naming conventions:

- System 1 (Figure 1-1) refers to the VAX-11/730 system with two RL02 disk drives.
- System 2 (Figure 1-2) refers to the VAX-11/730 system with one RL02 disk drive and one R80 disk drive.
- VAX-11/730 SBB (Figure 1-3) refers to the VAX-11/730 System Building Block.

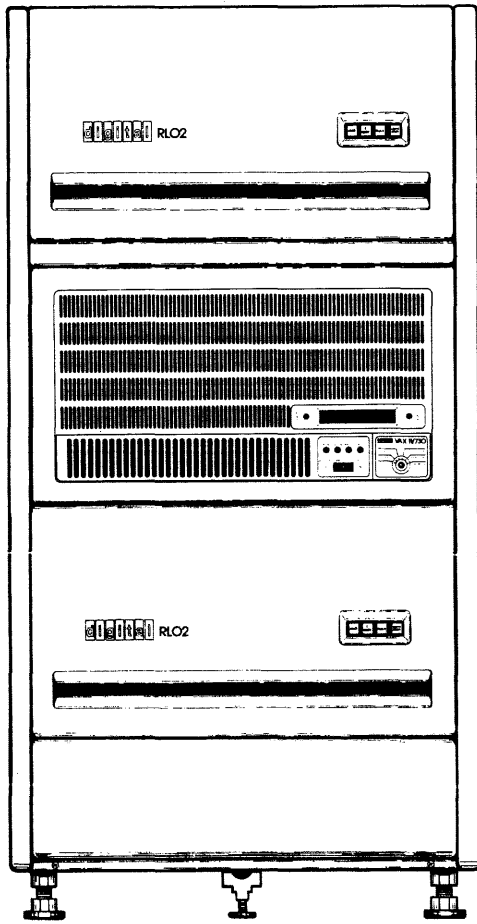

TK-8375

Figure 1-1 VAX-11/730 System 1 Cabinet

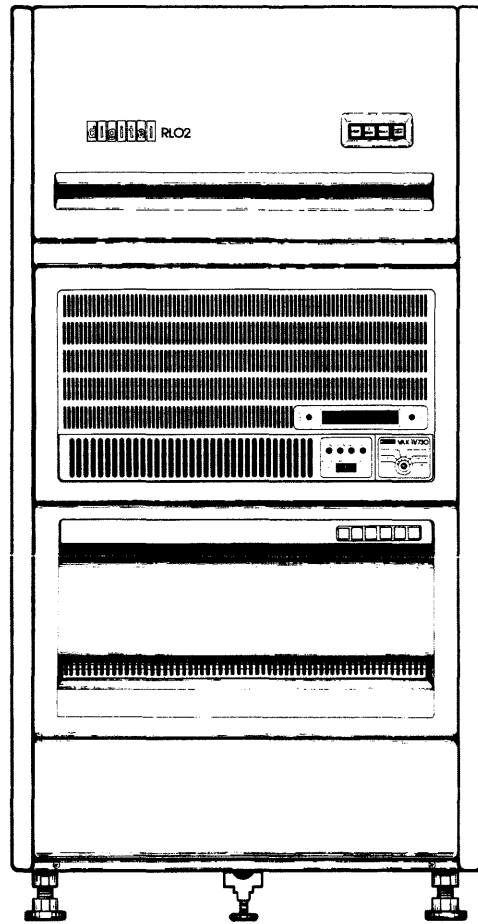

TK-8376

Figure 1-2 VAX-11/730 System 2 Cabinet

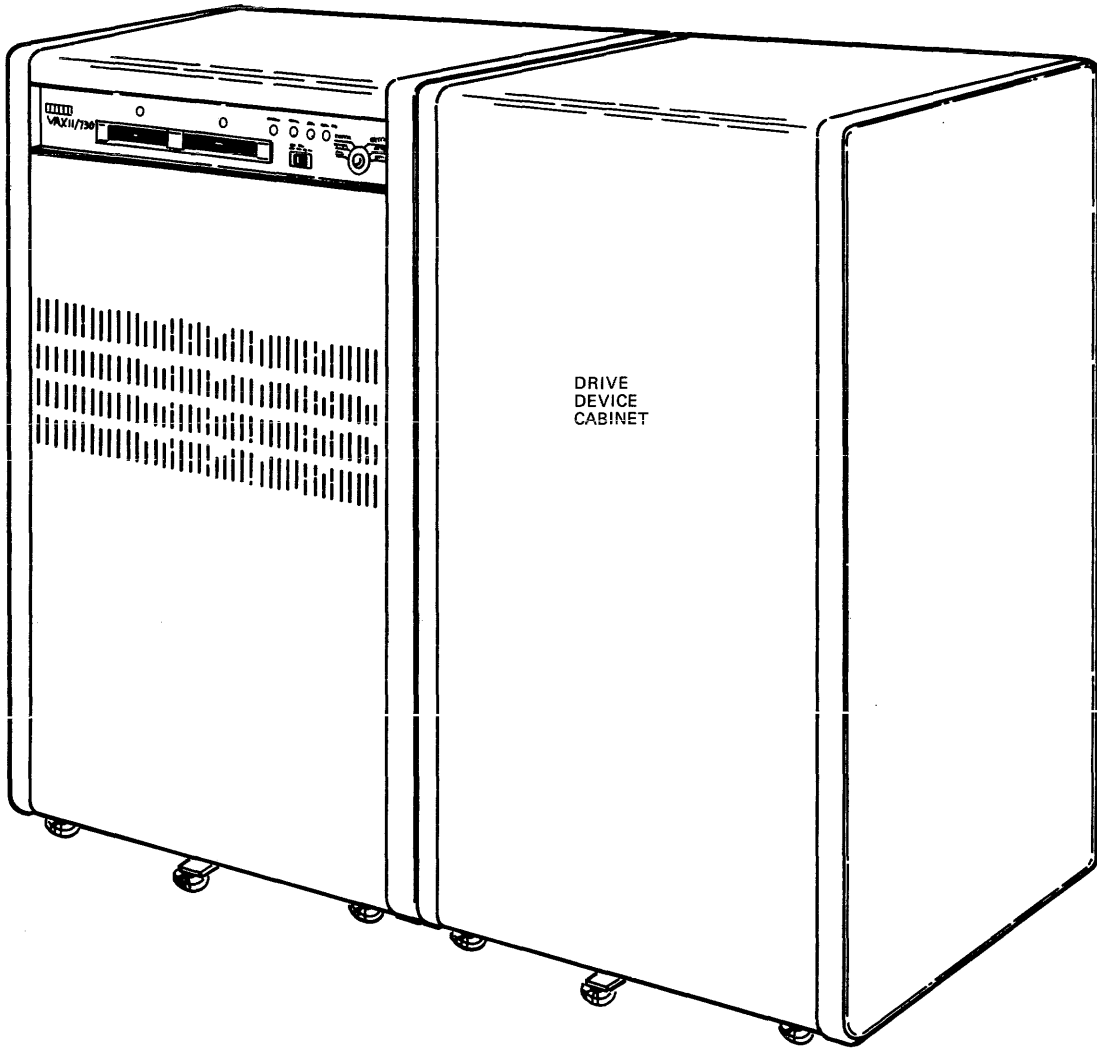

TK-11146

Figure 1-3 VAX-11/730 SBB Cabinet

1.3 RELATED DOCUMENTATION

Table 1-1 lists the documentation related to the VAX-11/730 system.

Table 1-1 Documents Related to the VAX-11/730 System

Title	Document Number
<i>Central Processor Unit Technical Description</i>	EK-KA730-TD
<i>Memory System Technical Description</i>	EK-MS730-TD
<i>FP730 Floating-Point Accelerator Technical Description</i>	EK-FP730-TD
<i>Integrated Disk Controller Technical Description</i>	EK-RB730-TD
<i>System Maintenance Guide</i>	EK-11730-PG
<i>VAX Diagnostic System User's Guide</i>	EK-VX11D-UG
<i>Diagnostic Overview Manual</i>	EK-DS730-UG
<i>Site Preparation Data Sheets</i>	EK-CORP-SP
<i>VAX-11/730 Hardware User's Guide</i>	EK-11730-UG
<i>H7202B Power Supply Technical Description</i>	EK-PS730-TD
<i>VAX Architecture Handbook</i>	EB-21811
<i>VAX Hardware Handbook</i>	EB-21711
<i>DMF32 Multi-Function Communications User's Guide</i>	EK-DMF32-UG
<i>BA11 Mounting Box and Power System Technical Description</i>	EK-BA11-A-TM
<i>KC730 Remote Diagnostics Option Technical Manual</i>	EK-KC730-TM
<i>UDA50 User Guide</i>	EK-UDA50-UG
<i>UDA50 Service Manual</i>	EK-UDA50-SV

CHAPTER 2

SYSTEM CABINET PREPARATION

2.1 GENERAL

Digital Equipment Corporation ships the various parts of the VAX-11/730 system in crates and boxes. Some of the equipment is mounted on skids as well. The customer is responsible for moving the equipment to the installation site.

This chapter provides step-by-step procedures for taking a shipment inventory, and unpacking the system equipment.

2.2 BOXED EQUIPMENT

The VAX-11/730 system cabinet and peripheral cabinets are mounted separately on skids. Peripheral devices are either mounted separately on skids or packed in consolidated boxes and attached to skids by hold-down straps. Fork lifts and mobile lifters can be used to move the packaged equipment.

If consolidated boxes contain more than one item that cannot be moved to the installation area, they must be opened so that the small box contents can be moved separately.

2.3 MOVING CONSTRAINTS

The moving of cabinets from the receiving area to the installation area should be planned in advance of the delivery date. Ensure that the sizes of doors, elevators, passageways, and ramps are checked for height, width, and turning radius requirements.

2.4 SHIPMENT INVENTORY

1. Ensure that all VAX-11/730 equipment is moved to the designated installation site (a customer responsibility).
2. Inventory all equipment against the shipping list accompanying the shipment.
3. Ensure that the system cabinet and free-standing peripherals are in the containers and unopened.
4. Ensure that all separate and consolidated boxes are sealed.
5. Any opened packages or cabinets should be called to the attention of the customer and documented on the LARS report.
6. Notify the unit manager of any missing or incorrect items.
7. Have the customer contact the carrier to locate any missing items.
8. Have the unit manager check with the DIGITAL Traffic and Shipping Department if the carrier does not have the missing items.
9. Check all the boxes for external damage (dents, holes, smashed corners).
10. Notify the customer of all damage and list on the LARS report. Photographs are useful in clarifying the extent of the damage.

2.5 UNPACKING BOXES

1. Open all boxes and inventory the contents against the shipping/accessory list.
2. Inspect the equipment for damage. Report any damage to the customer and on the LARS report.
3. If the damage is extensive, call the unit manager for instructions on how to proceed.

2.6 UNPACKING THE SYSTEM CABINET

Refer to Figure 2-1, and unpack the system cabinet as follows:

1. Cut the two polyester straps.
2. Remove the cap, two ramps, installation hardware bag, and the cardboard spacer from the packaging container.
3. Lift up and remove the stitched tube and polyethylene bag that encloses the cabinet.

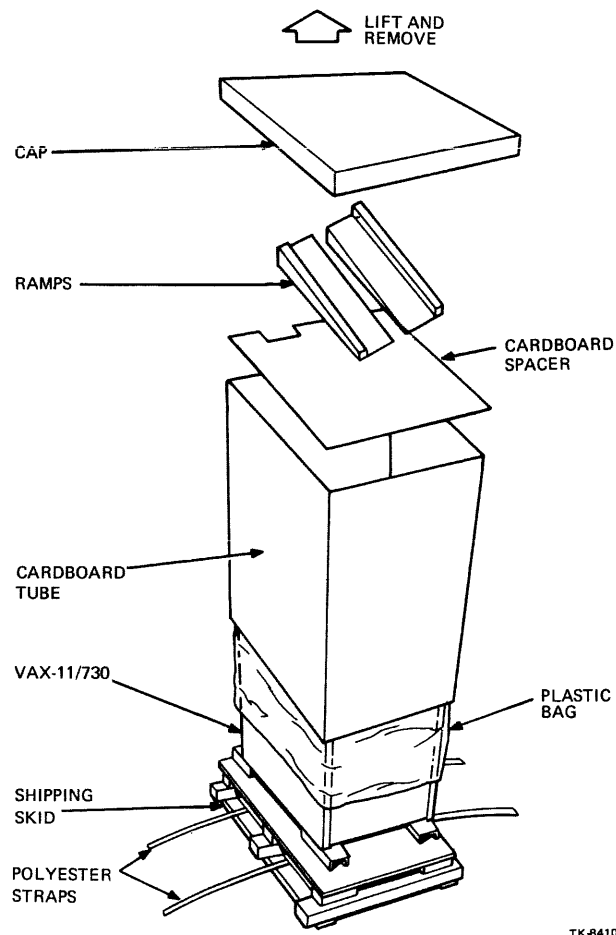
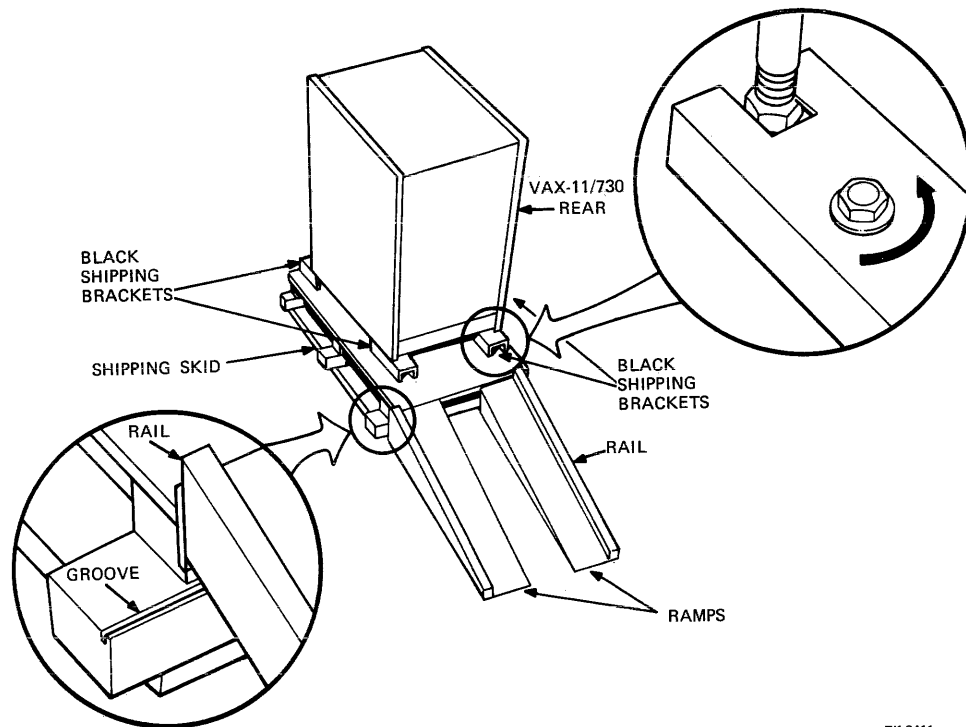

Figure 2-1 Unpacking the VAX-11/730 System Cabinet



TK-8411

Figure 2-2 Attaching the Ramps and Removing the Shipping Brackets from the VAX-11/730

4. Attach the two ramps to the rear of the shipping skid (Figure 2-2) by sliding the metal plate into the large end of the ramp into the groove of the skid.
5. Use the 9/16-inch open-end wrench to remove the four black shipping brackets located at the bottom of each corner of the cabinet.
6. Raise the four leveling feet by turning the top nut down to the bottom of the feet, then turning the bottom nut up.
7. Ensure that the ramps are straight and secure, then gently roll the cabinet down the ramps.

NOTE

Allow 10 feet of clearance from the rear of the shipping skid to remove the cabinet.

WARNING

EXTREME CARE SHOULD BE TAKEN; the cabinet weighs in excess of 250 pounds. Two people should remove the cabinet.

2.7 UNPACKING OTHER CABINETS

Unpack the UNIBUS expansion and drive device cabinets as specified in the documentation shipped with that equipment.

CHAPTER 3

VAX-11/730 SYSTEMS 1 AND 2 HARDWARE INSTALLATION

3.1 GENERAL

This chapter provides the following step-by-step procedures for the VAX-11/730 Systems 1 and 2:

- System cabinet installation
- Device preparation prior to power-up
- System power-up
- RL02 setup

NOTE

In this chapter RIGHT and LEFT refer to side directions when facing the front of the cabinet.

3.2 VAX-11/730 CABINET CONFIGURATION GUIDELINES

When installing the VAX-11/730 system, observe the following guidelines on cabinet and system configuration:

1. The VAX-11/730 system cabinet is always the leftmost cabinet in the string of physically joined cabinets.
2. The VAX-11/730 system is expanded two cabinets to the right.
3. Drive device cabinets are not attached to other cabinets, except in the case where a disk drive is included in the expander cabinet.

3.3 VAX-11/730 SYSTEMS 1 AND 2 CABINET INSTALLATION

This section covers the installation of the system and expander cabinets. This installation includes joining the expander cabinet to the system cabinet.

3.3.1 System Cabinet Installation

The system cabinet can be positioned alone or attached to the UNIBUS expander cabinet. To install the system cabinet, perform the following steps:

1. Roll the system cabinet into the installation position.
2. Adjust the leveler feet (Figure 3-1) on the cabinet for contact with the floor. Tighten the hex nut on each foot. Adjust the leveler foot on the stabilizer arm, in the extended position, for contact with the floor.
3. Installation of the terminal and peripheral devices (expander cabinets, drive cabinets, printer, console terminal, etc.) should be done at this time.

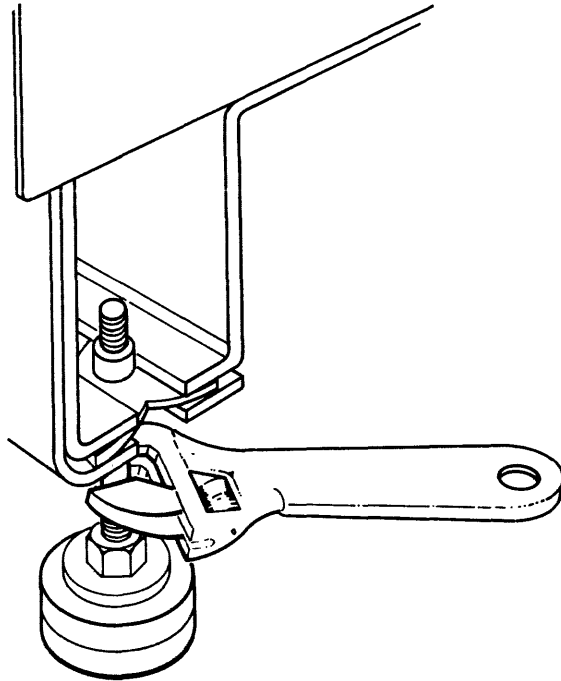

TK-11147

Figure 3-1 Leveler Feet Adjustment

3.3.2 UNIBUS Expander Cabinet Installation

If a UNIBUS expander cabinet is included in the system configuration, perform the following steps to install the expander cabinet:

1. Roll the expander cabinet into the installation position (close to the system cabinet).
2. Remove the system and expander cabinet rear doors by performing the steps below (Figure 3-2):
 - a. Use a 5/32-inch hex wrench to release the two quarter-turn door fasteners.
 - b. Tilt the top of the door away from the cabinet and lift the door until the lower hinge pins are removed from the holes in the right and left door brackets.
3. Remove the right-end panel from the system cabinet by grasping the panel by the front and rear ends, and lifting the panel approximately 1 inch (Figure 3-3).
4. Remove the cabinet joiner panel from the expander cabinet left side, by grasping the panel by the front and rear ends and lifting it approximately 1 inch (Figure 3-4).
5. Remove the four leveler feet and leveler nuts from the cable trough/stabilizer bar kit (Figure 3-5). Assemble and install them into the base corners on the expansion cabinet (Figure 3-6).

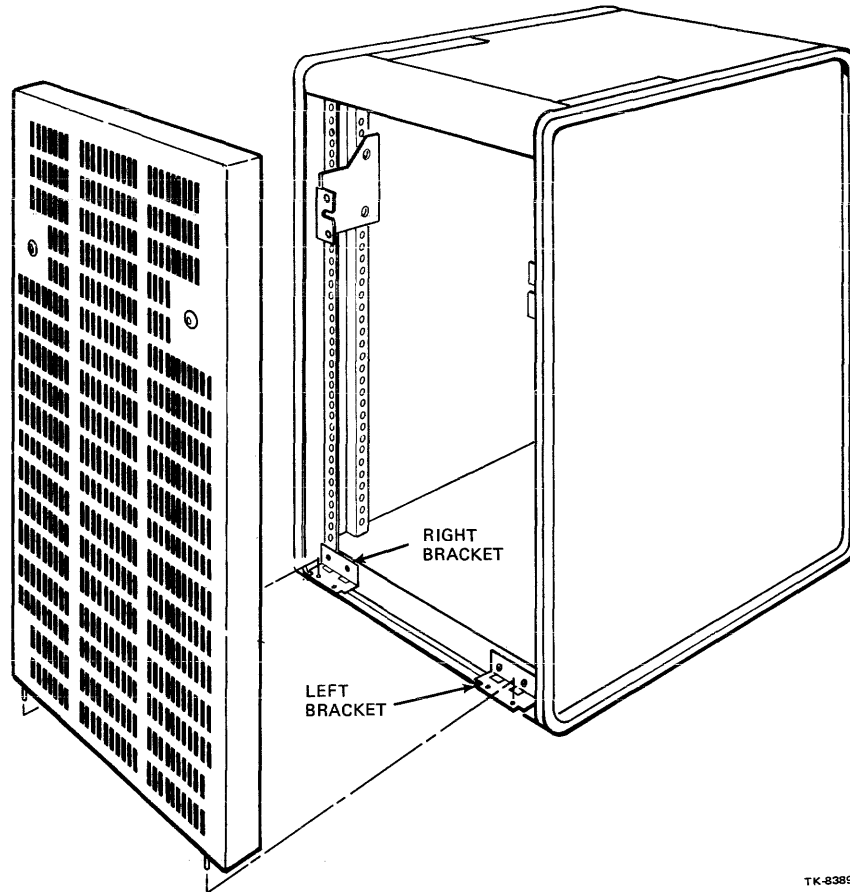
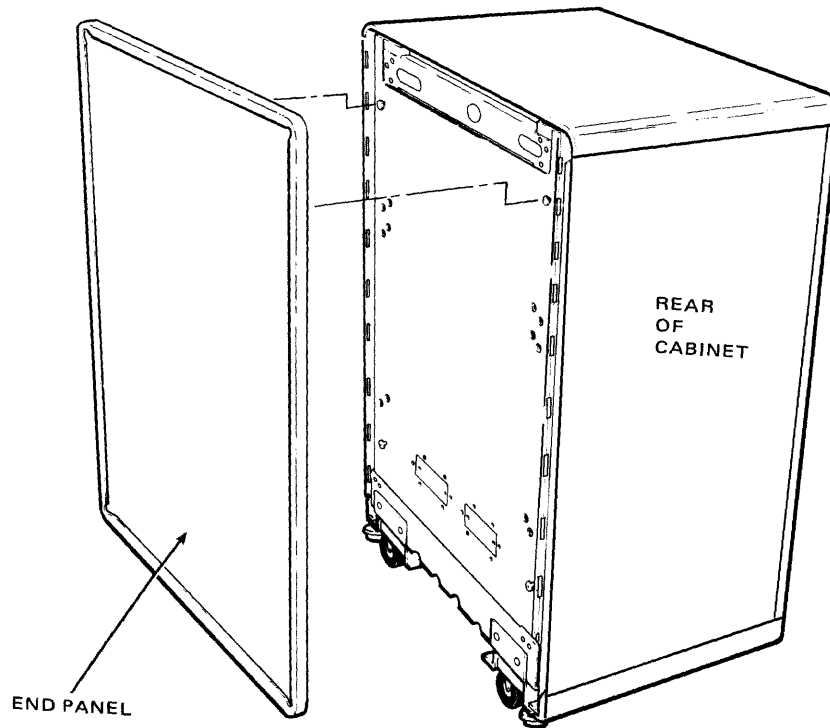

Figure 3-2 System and Expander Cabinet Rear Door Removal and Replacement

6. Loosely install the joiner panel on the right side of the system cabinet.
7. Raise the joiner panel on the system approximately 1 inch and position the expander cabinet against the system cabinet (Figure 3-7).
8. Adjust the expander cabinet leveler feet to obtain alignment of the two cabinets.
9. Push the joiner panel down engaging the key buttons on the system and expander cabinets into the slots on the joiner panel (Figure 3-7).
10. Bolt the cabinets together at the bottom front and rear by removing the screws from the system and expander cabinets door brackets, then sliding the interconnecting bar behind the front edge of the joiner panel and over the door brackets, as shown in Figure 3-8. Install the bracket screws and tighten.



TK-11146

Figure 3-3 Cabinet End Panel Removal

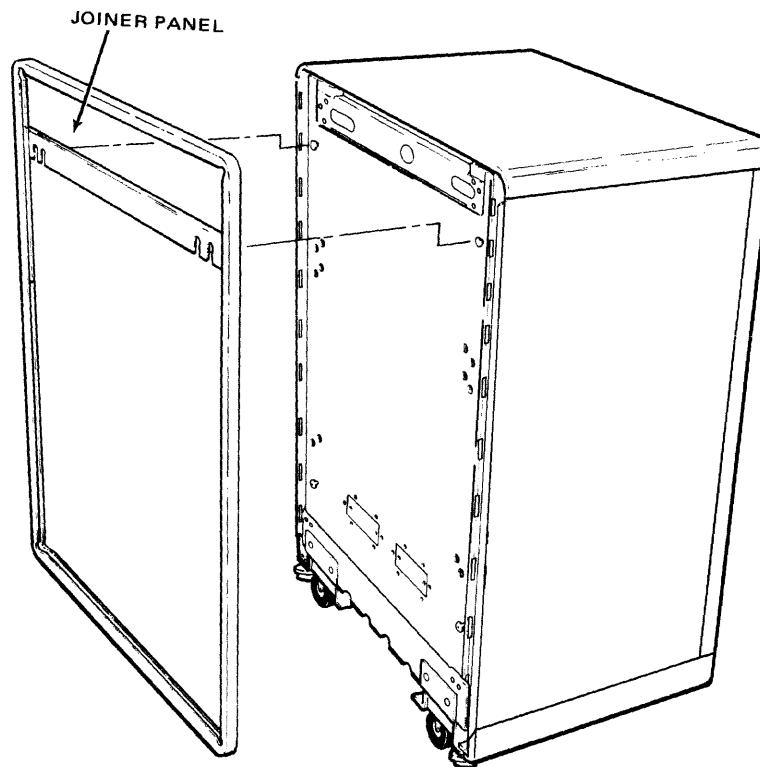

TK-11149

Figure 3-4 Cabinet Joiner Panel Removal

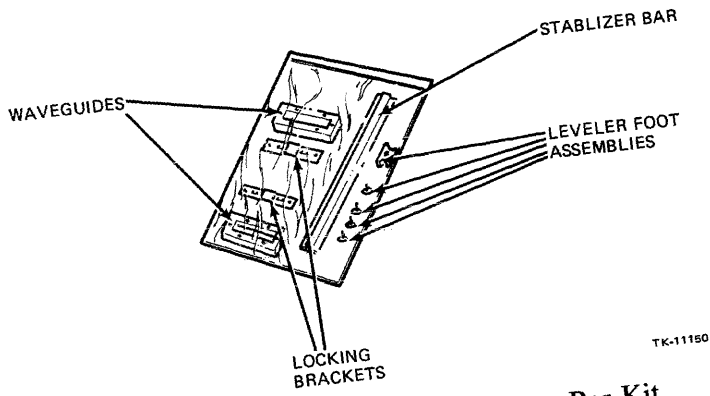

TK-11150

Figure 3-5 Cable Trough/Stabilizer Bar Kit

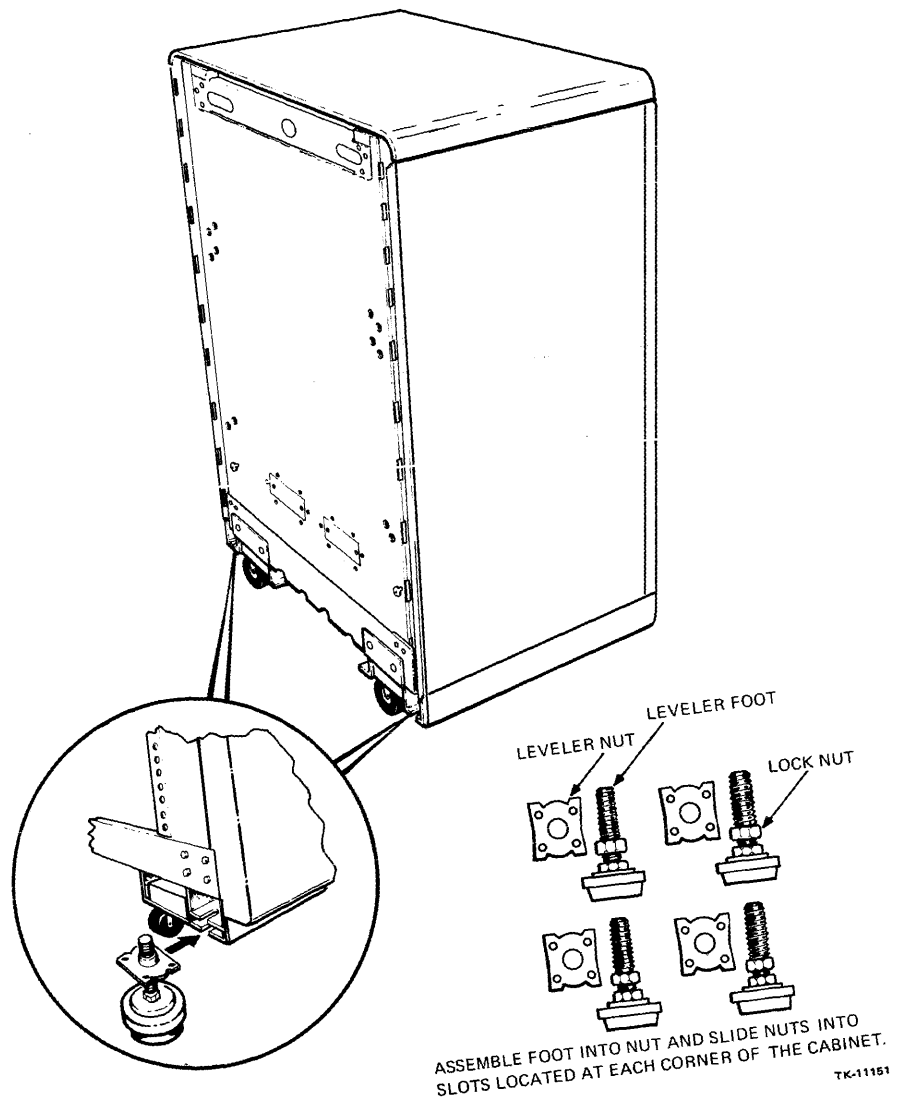

TK-11151

Figure 3-6 Leveler Feet Assembly and Installation

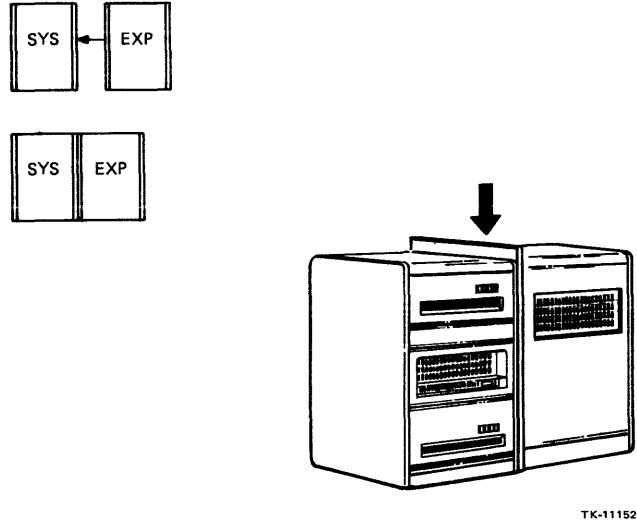

Figure 3-7 Joining the System and Expander Cabinets

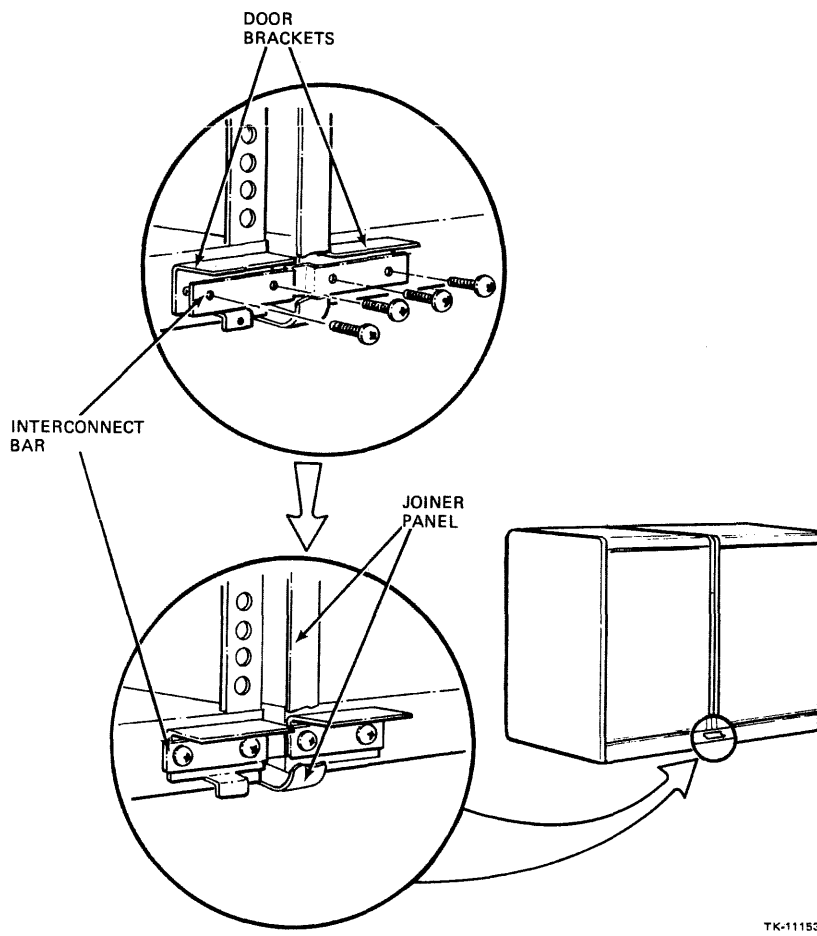

Figure 3-8 Bolting the Joined Cabinets Together

11. Install the right-end panel on the right side of the expander cabinet that was removed from the system cabinet in step 3.
12. Install the stabilizer bar into the expansion cabinet by performing the following steps (Figure 3-9):
 - a. Remove the stabilizer bar and leveler foot from the cable trough/stabilizer bar kit (Figure 3-5).
 - b. Screw the leveler foot into the stabilizer bar.
 - c. Insert the stabilizer bar, foot first, into the channel located at the bottom rear of the cabinet.
 - d. Remove the retaining cable and screw from the back of the cabinet base and attach it to the underside of the stabilizer bar.

NOTE

The retaining cable is used to limit the forward extension of the stabilizer bar.

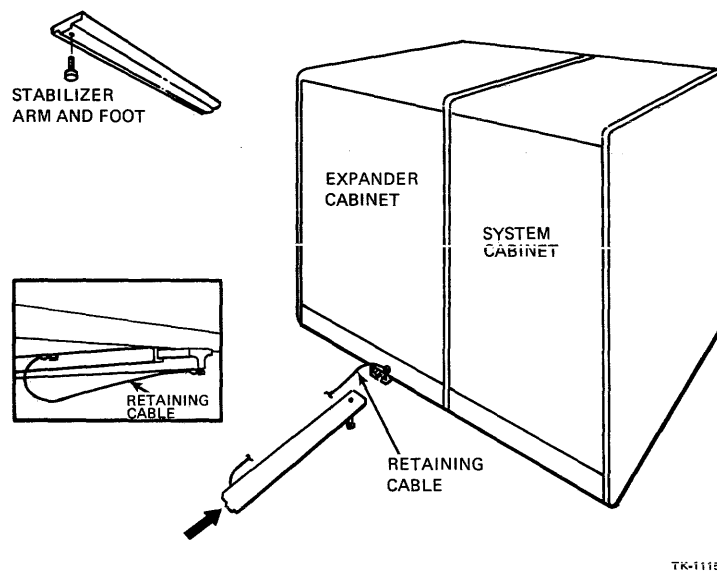

Figure 3-9 Stabilizer Bar Installation (Rear View)

3.4 VAX-11/730 SYSTEMS 1 AND 2 DEVICE PREPARATION

Some system devices must be checked and/or prepared prior to system power up. Device preparation is described in the following paragraphs.

CAUTION

Ensure that the stabilizer bar on the system cabinet is in the extended position to prevent tipping of the cabinet when devices are extended.

3.4.1 CPU Mounting Box (BA11-Z)

Prepare the mounting box by performing the following steps:

1. Using a 7/16-inch wrench, remove the restraint nut and the red shipping restraint in the right rear side of the CPU box (Figure 3-10).
2. Disconnect the service interlock tether located on the cable carrier at the rear of the CPU box (Figure 3-11).

NOTE

Once the device preparation is completed, reconnect the service interlock tether that was removed in step 2.

3.4.2 Cabling Check

Ensure that all system cabinet cabling is free of damage and properly connected on the following:

- RL02 – The round cable exiting from the top connector on the drive rear connects to the DMF32 I/O panel in the middle right side of the rear of the cabinet. The bottom connector on the drive rear contains the standard RL02 terminator. The ac power cord should plug into a switched outlet on the power controller.
- R80 – The two cables exiting from the drive rear should enter the lower middle of the system I/O panel. The ac power cord should be connected to a switched outlet on the power controller.
- CPU – The CPU DEC POWER CONTROL BUS cable connected to the power supply at the rear of the mounting box must be connected to one of the four DEC POWER CONTROL BUS connectors on the power controller. The ac power cord must be connected to an unswitched outlet on the power controller.

3.4.3 RL02 Disk Drive

Prepare the RL02 disk drive after system power has been applied (Paragraph 3.6).

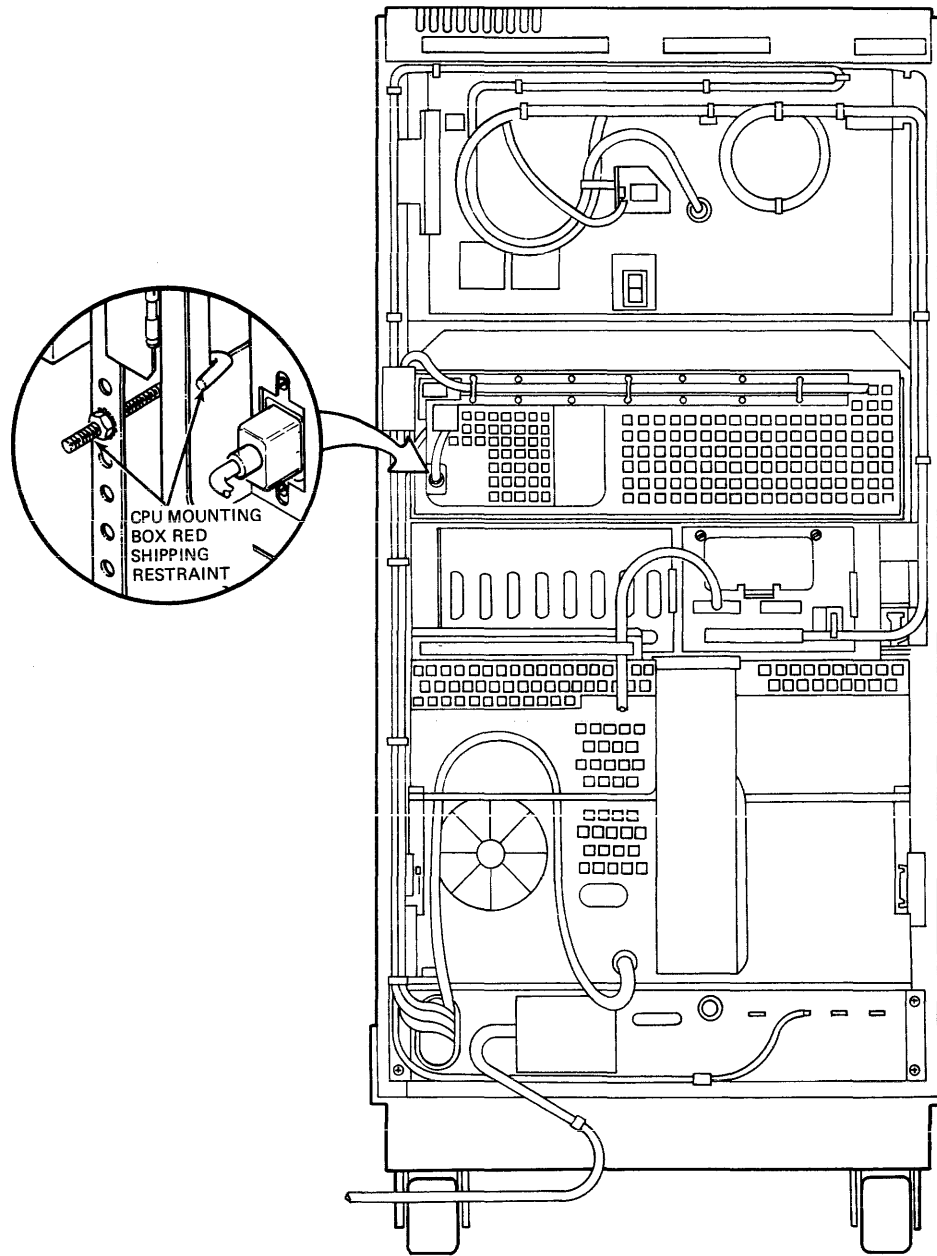

TK-8438

Figure 3-10 CPU Box Shipping Restraints

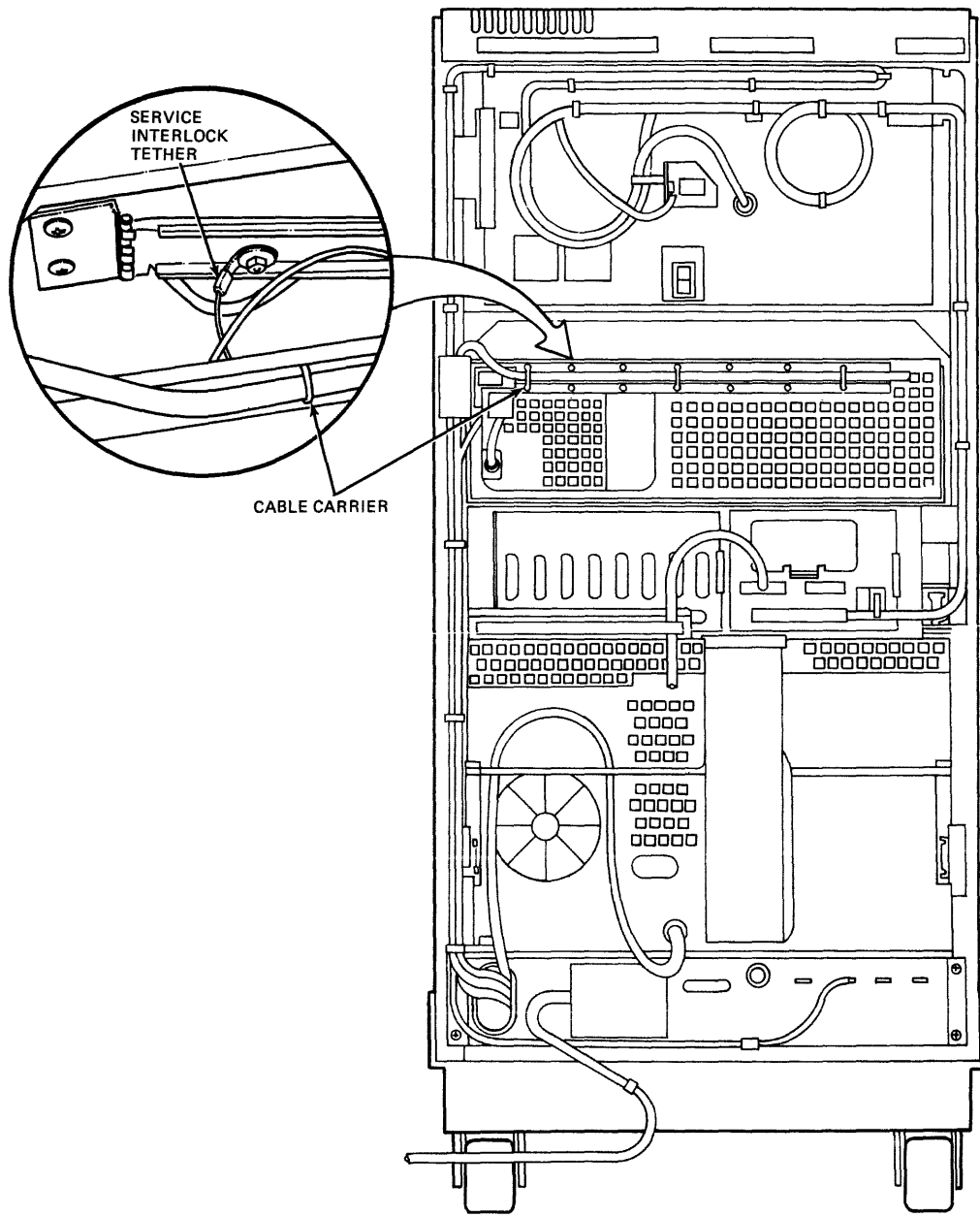

TK-8436

Figure 3-11 CPU Box Service Interlock (Tether)

3.4.4 R80 Disk Drive

Perform the following steps to prepare the R80 disk drive for operation:

1. Remove the Phillips head quarter-turn service interlock screw from the restraint bracket at the right rear of the R80 drive (Figure 3-12).
2. Withdraw the disk drive from the cabinet until the back hinge is completely exposed.
3. Unlatch and raise the logic access cover by rotating the cover latch 90 degrees counterclockwise (Figure 3-13).
4. Remove the packing material from between the logic access cover and the circuit module, and from between the modules themselves.
5. Fold out the hinged circuit board modules and check to ensure that all cable connectors are firmly seated.
6. Return the circuit board modules to their original horizontal position. Close the logic access cover until the latches snap shut.
7. Using a small screwdriver push in the logic chassis assembly release latch located behind the lower middle of the front bezel and raise the logic chassis assembly to expose the head disk assembly (HDA) (Figures 3-13 and 3-14).
8. Loosen the four HDA mounting nuts and remove the four 5/6-inch hex-head bolts on the **red** shipping restraints, then slide the three restraints from under the mounting nuts (Figure 3-15).
9. Remove the shipping bolt and jam nuts that secure the shipping restraint to the spindle motor assembly and slide the shipping restraint from under the mounting nut. Tighten the four HDA mounting nuts.

NOTE

Save all shipping material, brackets, and hardware for future use when moving equipment.

10. Examine the HDA to ensure that all cables are firmly connected.
11. Rotate the **POSITIONER LOCK LEVER**, located toward the front of the HDA (Figure 3-15), counter clockwise from the **LOCK** position (3 o'clock) to the **UNLOCK** position (9 o'clock).

CAUTION

Always rotate the POSITIONER LOCK LEVER clockwise to LOCK and counterclockwise to UNLOCK. Any other rotation will destroy the heads.

12. Ensure that the **BELT-TENSION LEVER** (Figure 3-14) is in the locked (forward) position.
13. Lower the logic chassis assembly into place. The latch will automatically secure the assembly when it is lowered.
14. Depress the slide locks, push the R80 drive into the cabinet and install the service interlock screw into the restraint bracket at the drive rear (removed in step 1).

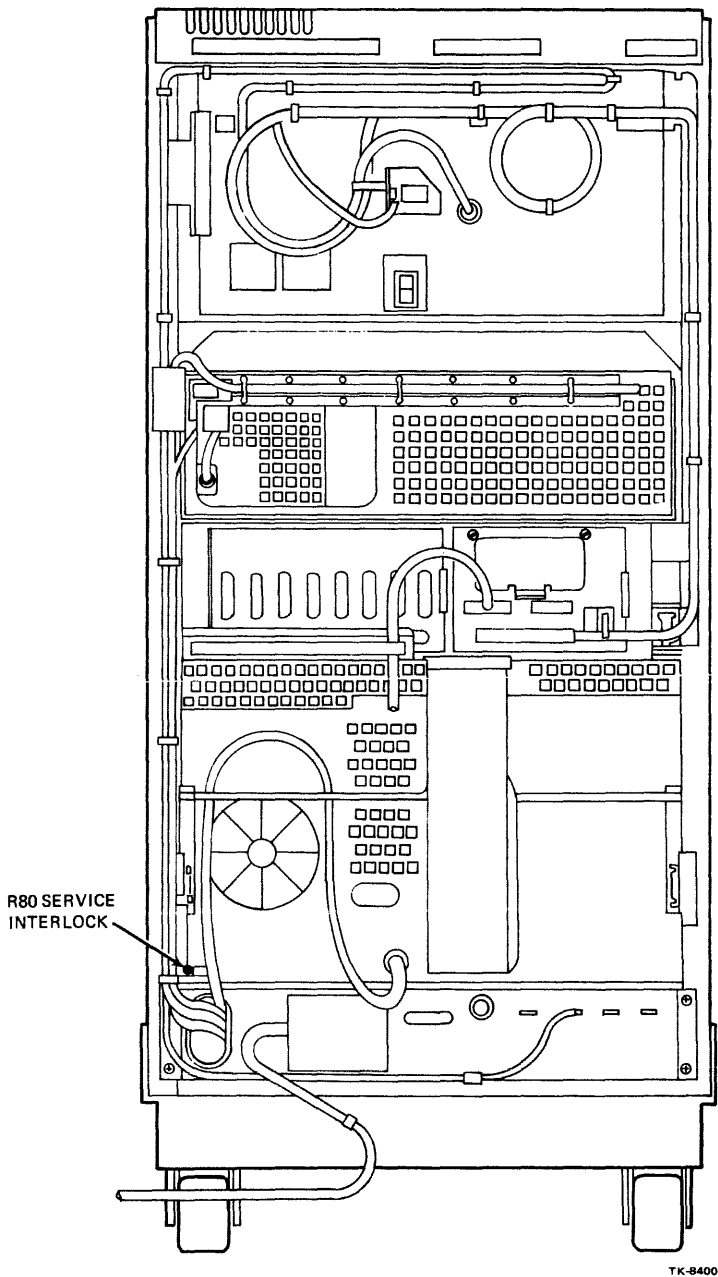

TK-8400

Figure 3-12 R80 Service Interlock

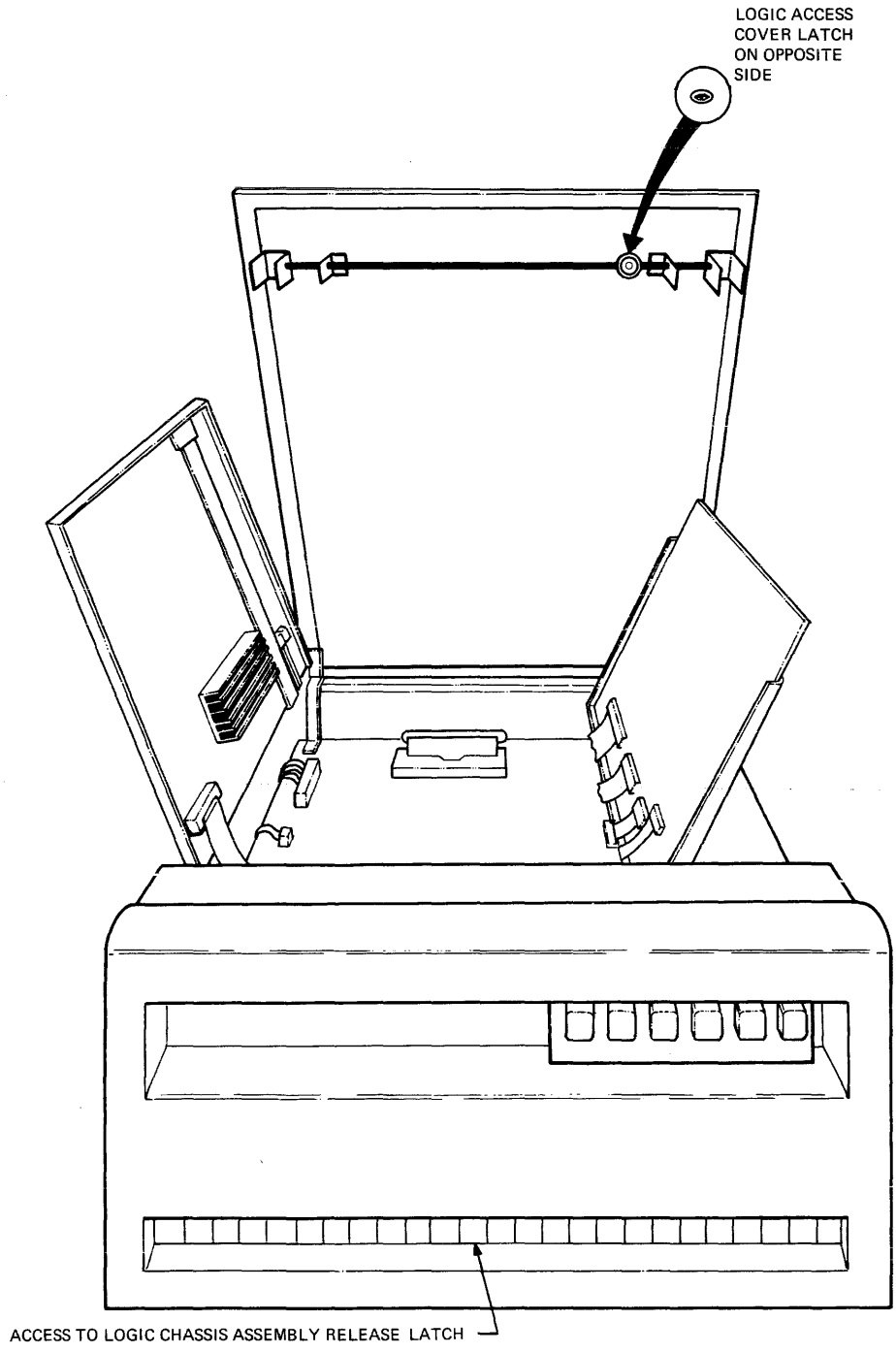

Figure 3-13 R80 Logic Chassis Exposed (Logic Access Cover Raised)

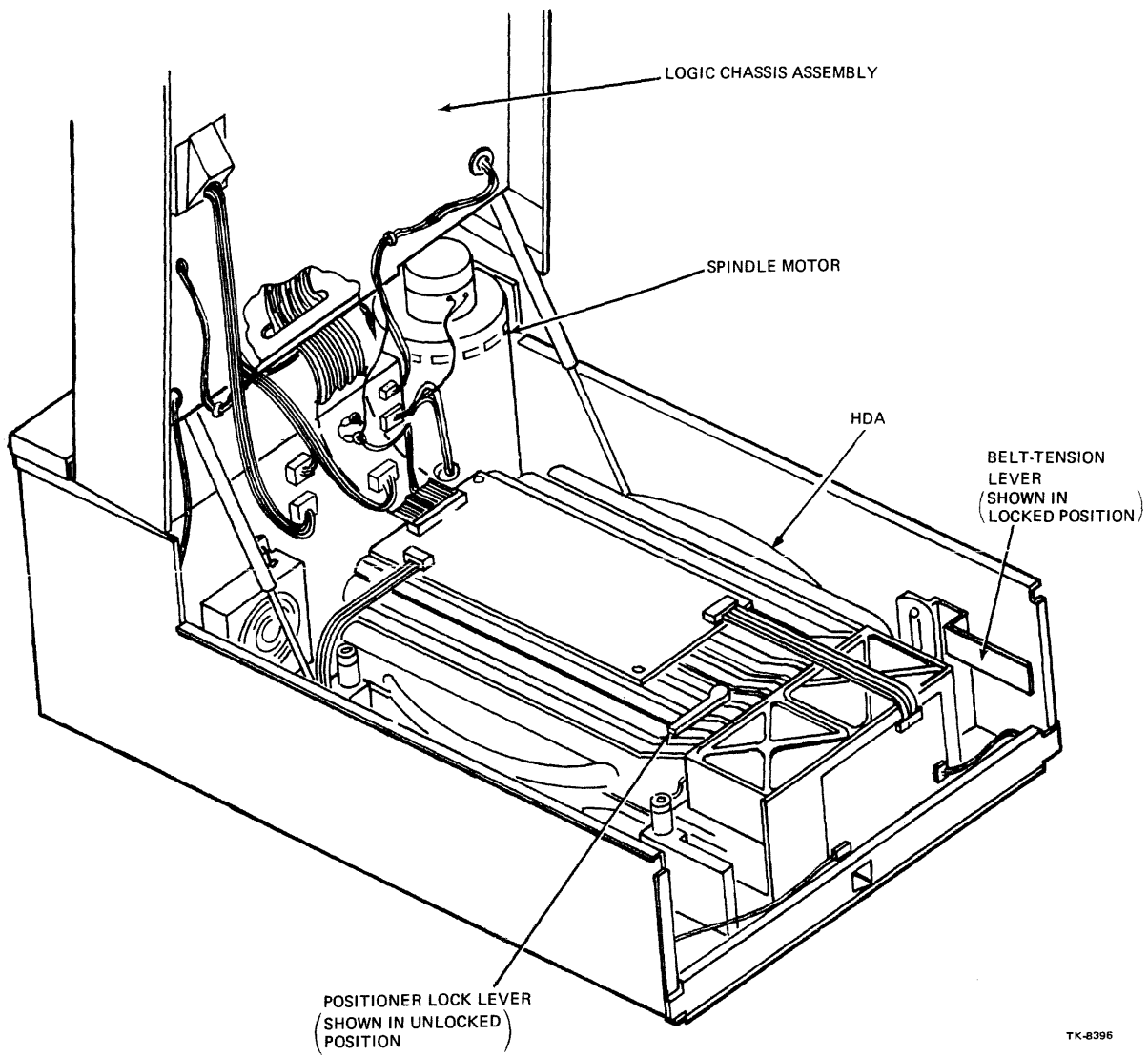
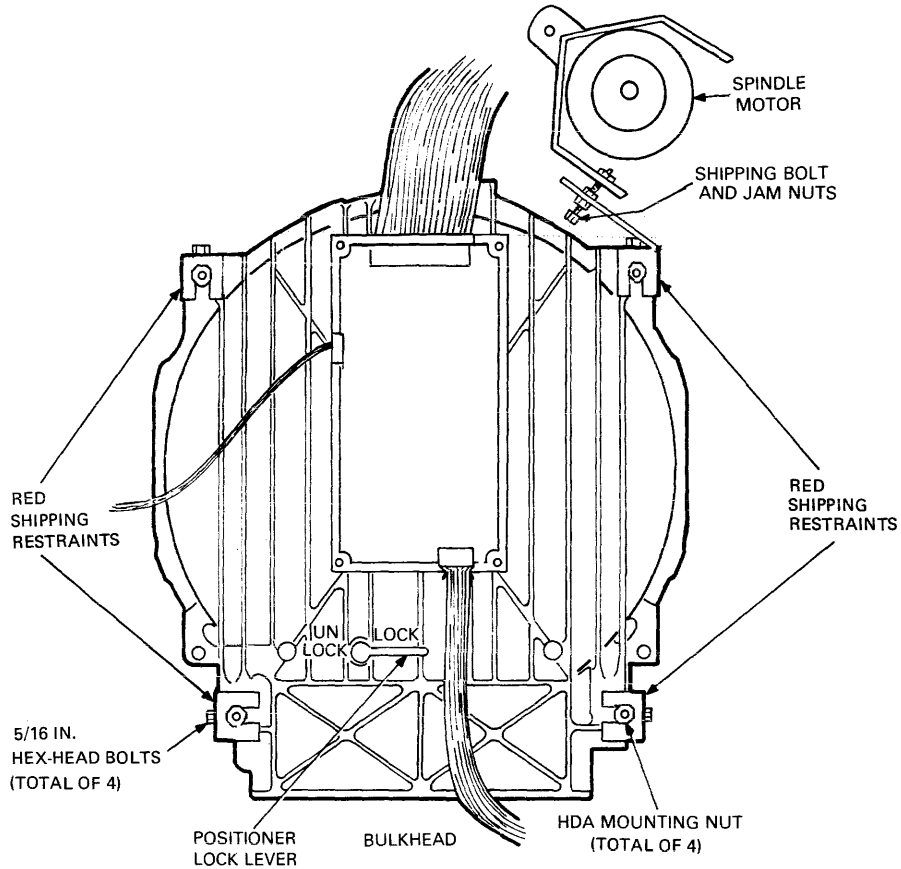

Figure 3-14 R80 Head Disk Assembly (HDA) Exposed (Logic Chassis Assembly Raised)



TK-8387

Figure 3-15 R80 HDA Shipping Restraints

3.4.5 Console Terminal

Prepare the console terminal as specified in the documentation supplied with the equipment.

3.4.6 WCS Module (Switch Settings)

Follow the procedure below to set up the terminal baud rate on the WCS module (refer to Figures 3-16, 3-17 and 3-18):

1. Withdraw the CPU box from the cabinet and open the module access cover on the left side of the CPU box by releasing the four Phillips head quarter-turn fasteners.
2. Disconnect the two cables and remove the WCS module (M8394, Slot 5).

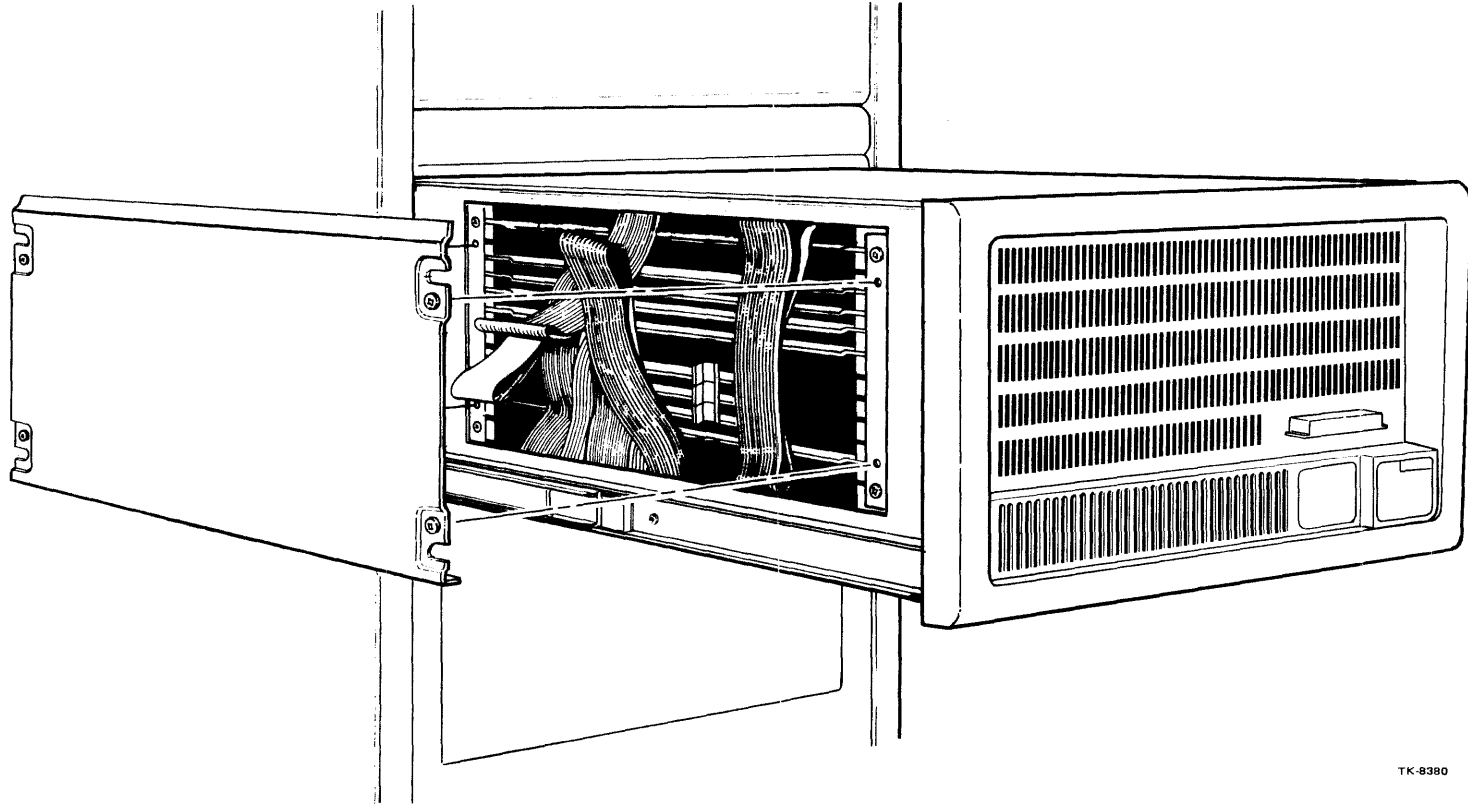

TK-8380

Figure 3-16 Module Access Cover Removal

USAGE	SLOT	
IDC	1	RB730 (M8388)
FPA	2	FP730 (M8389)
DAP	3	KA730 CPU (M8390)
MCT	4	KA730 CPU (M8391)
WCS	5	KA730 CPU (M8394)
MEMORY	6	MS730-CA (M8750)
MEMORY	7	MS730-CA (M8750)
MEMORY	8	G7273
MEMORY	9	G7273
MEMORY/TV80	10	G7273
COMBO	11	DMF32-AA (M8396)
UNIBUS & SPC	12	M9302 G7273
		A B C D E F

TK-8255

Figure 3-17 Module Use Chart

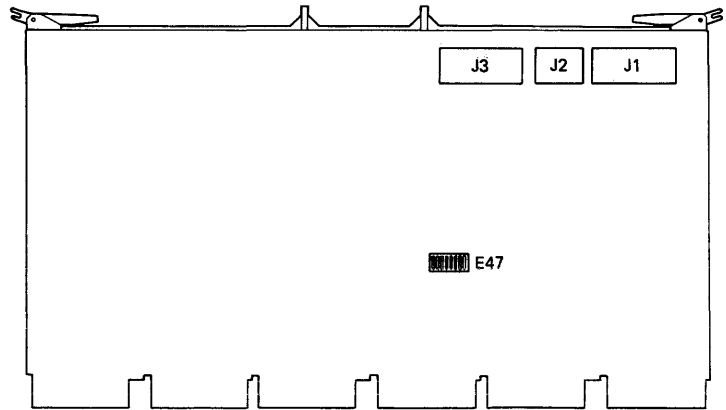

TK-11156

Figure 3-18 Switchpack and Connector Locations on the WCS Module

3. Locate the E47 switchpack on the module, then follow Table 3-1 for the switch setting corresponding to the baud rate.

No other baud rates are provided. The normal baud rate for the console terminal is 2400 baud.

4. Return the WCS module to slot 5 and reconnect the two cables.

Table 3-1 The WCS Module E47 Switchpack Switch Settings and Corresponding Console Baud Rates

Switch	Console Baud Rate
E47-3 OFF E47-4 OFF	9600
E47-3 OFF E47-4 ON	2400
E47-3 ON E47-4 OFF	1200
E47-3 ON E47-4 ON	300

3.4.7 DMF32 Module (Switch Settings)

Ensure that the two switchpacks on the DMF32 module are correctly set. These switchpacks set the interrupt priority level (switchpack E77) and the beginning floating UNIBUS address (switchpack E75) to be used.

To check the setting of the interrupt priority level and beginning UNIBUS address, follow the steps below (refer to Figures 3-17 and 3-19):

1. Disconnect the cables from the DMF32 module (M8396, slot 11) and remove the module.
2. Locate the E77 and E75 switchpacks, then check the switches for the settings in Tables 3-2 and 3-3.
3. Return the DMF32 module to slot 11, reconnect the three cables to the module, replace the module access cover, then push the CPU box back into the cabinet.

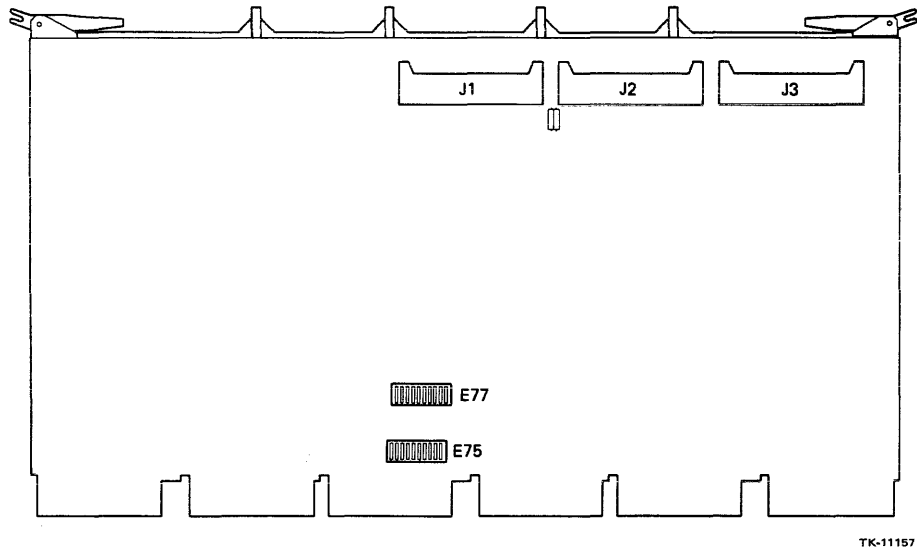

Figure 3-19 Switchpack and Connector Locations on the DMF32 Module

Table 3-2 DMF32 Module Switchpack E77 Settings for Interrupt Priority Levels BR5 and BR6

Switch	BR5	BR6
E77-1	ON	OFF
E77-2	ON	OFF
E77-3	OFF	ON
E77-4	OFF	ON
E77-5	OFF	ON
E77-6	OFF	ON
E77-7	ON	OFF
E77-8	ON	OFF
E77-9	ON	OFF
E77-10	OFF	OFF

**Table 3-3 DMF32 Module Switchpack E75 Settings
for Beginning UNIBUS Address FE0E0**

Switch	Setting
E75-1	ON
E75-2	ON
E75-3	ON
E75-4	ON
E75-5	ON
E75-6	OFF
E75-7	OFF
E75-8	OFF
E75-9	ON
E75-10	ON

3.4.8 DMF32 I/O Panel (Switch Settings)

Preparation on the DMF32 I/O panel requires that three switchpacks be set on the panel. Switchpacks 1 and 2 control the modem bits for asynchronous lines 0 and 1 (connectors 1 and 2). Switchpack 3 controls modem bits for the synchronous line and selects one of the devices on the DMF32. Refer to Tables 3-4, 3-5 and 3-6 for switch settings on the switchpacks, and Figure 3-20 for switchpack location.

NOTE

Switches are set to the left for the ON position and to the right for the OFF position.

**Table 3-4 Switch Settings of Switchpacks 1 and 2
for Controlling Modem Bits of Asynchronous Lines 0 and 1**

Local Terminal	Devices	Common Modems	Switchpacks 1 and 2 Switch
OFF		OFF	1
ON		ON	2
OFF		OFF	3
ON		ON	4
ON		ON	5
ON		ON	6
ON		ON	7
ON		OFF	8
ON		ON	9
ON		ON	10

Table 3-5 Switch Settings of Switchpack 3 for Controlling Modem Bits of the Synchronous Line

Common Modems	Switchpack 3 Switch
ON	1
ON	2
ON	3

Table 3-6 Switch Settings of Switchpack 3 for the Devices on the DMF32

Device ASYNC	ASYNC LP	ASYNC DR SYNC	ASYNC LP SYNC	Switchpack 3 Switch
ON	OFF	ON	OFF	4
ON	ON	OFF	OFF	5

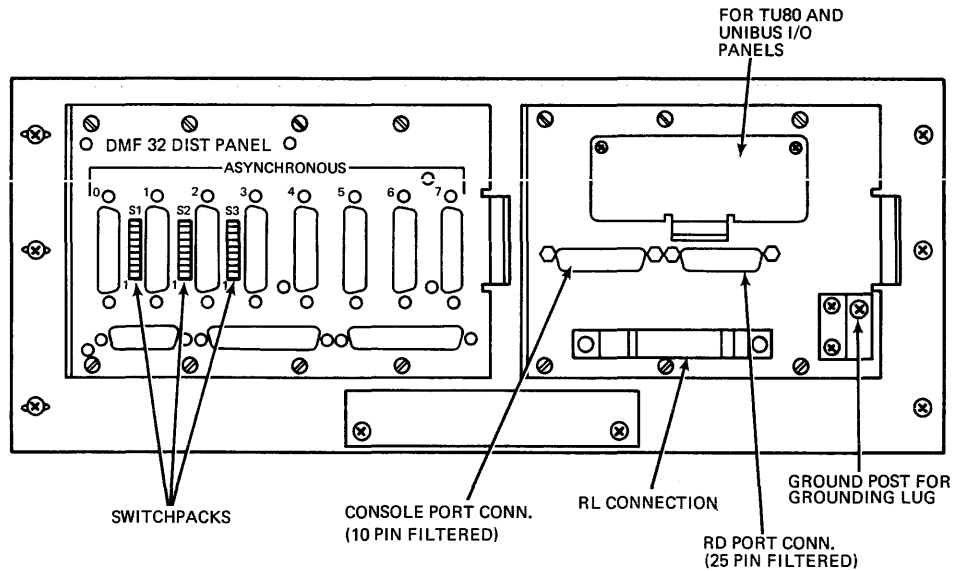

TK-11158

Figure 3-20 Switchpack Location on the DMF32 I/O Panel

3.5 VAX-11/730 SYSTEMS 1 AND 2 POWER-UP PROCEDURE

Perform the following steps to properly apply ac power to the system cabinet:

1. Ensure that the voltage on the input power label (Figure 3-21) of the ac power controller and R80 disk drive (in system 2) is the same as the facility ac power.
2. Ensure that the two indicators (Figure 3-21) on the rear of the RL02 disk drive are in the correct settings (one should read NOM for nominal variance, and the other should read the facility ac voltage level).

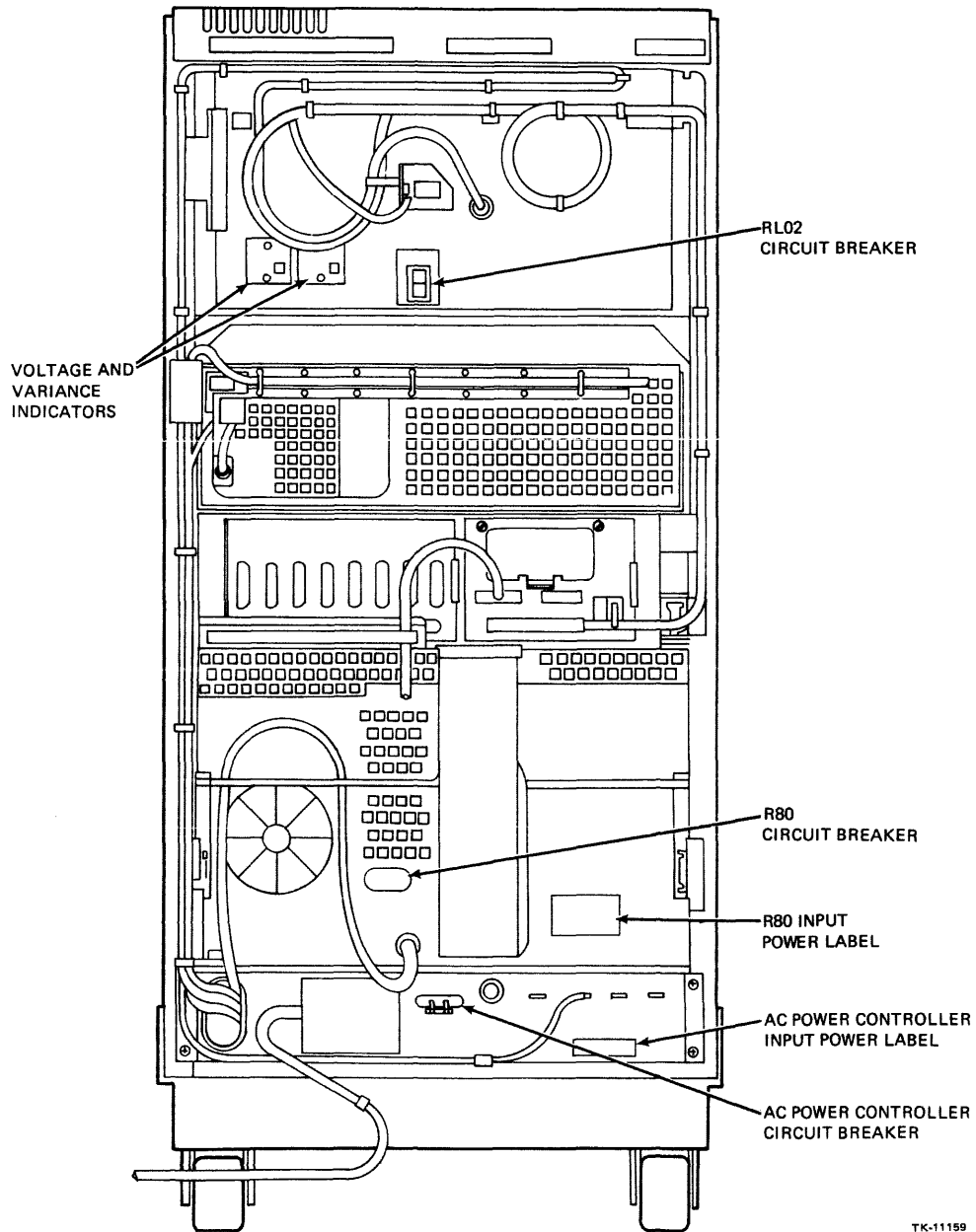
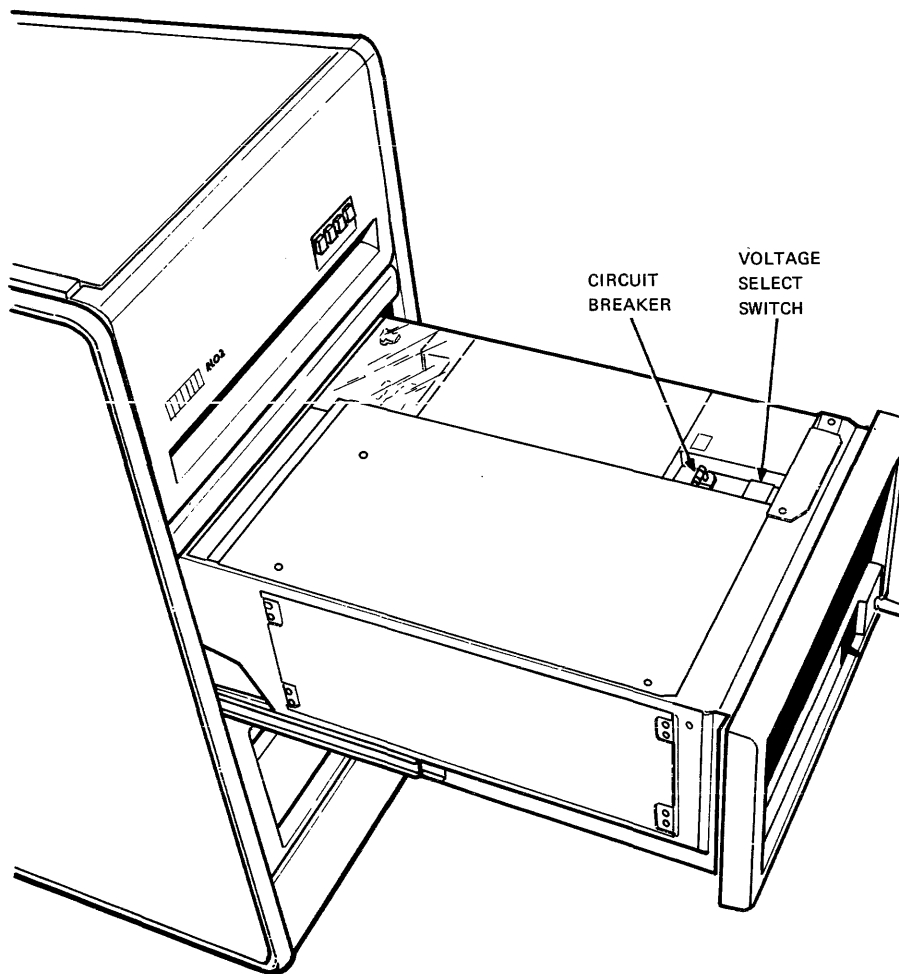

Figure 3-21 Rear View of the System Cabinet Showing RL02, R80, and 874 Voltage Tables and Circuit Breakers

3. Set the two disk drive circuit breakers to the up or 1 (ON) position and the ac power controller circuit breaker to the down or OFF position.
4. Set the ac power controller power control switch to the REMOTE ON position.
5. Withdraw the CPU box from the cabinet and ensure that the voltage selection switch on top of the box (Figure 3-22) is set to facility ac voltage level.
6. Connect the ac power controller power cord to the facility ac power.
7. Set the CPU box circuit breaker on top of the box to the 1 (ON) position and push the box into the cabinet.
8. Insert the CPU key into the CPU keyswitch on the CPU box front panel and turn the key to the LOCAL position.



TK-3381

Figure 3-22 CPU Box Circuit Breaker and Voltage Select Switch Locations

9. Perform the following steps to apply ac power to other cabinets in the system configuration:
 - a. Ensure that voltage labels and/or voltage switches on all equipment in other cabinets match the facility ac power.
 - b. Set all cabinet equipment function switches and circuit breakers to OFF.
 - c. Connect the cabinet's power controller ac cord to the facility ac power.
 - d. Set the circuit breaker on the cabinet power controller to ON.
 - e. Set the device's circuit breaker to ON.

3.6 RL02 SETUP

After ac power has been applied to the system, prepare the RL02 disk drive(s) for operation by following the steps below. These steps apply to both RL02 drives in system 1.

1. Ensure that the front panel LOAD button on the disk drive is in the out position.
2. If the disk drive is in the bottom of the cabinet, remove the red shipping restraint at the drive rear (Figure 3-23) and withdraw the drive from the cabinet.
3. Release the head assembly access cover latch located on the disk drive top and raise the cover.
4. In the head assembly area loosen the slotted head screw securing the positioner restraining bracket (Figure 3-24) and rotate the bracket 90 degrees. Then, tighten the screw.
5. Close the head assembly access cover until the latch snaps shut.
6. Press the slide locks and push the drive back into the cabinet.
7. Press the slide locks and push the CPU mounting box back into the cabinet.
8. Install the service interlock tether onto the rear of the CPU mounting box that was removed in Paragraph 3.4.1, step 2.
9. Install the rear door onto the system and expander cabinets by performing the steps below (see Figure 3-2):
 - a. Tilt the rear door and insert the hinge pins into the lower right and left brackets.
 - b. Ensure that all cabling is out of the way. Then, push the rear door into the cabinet.
 - c. Tighten the two hex head quarter-turn door fasteners to secure the door.

The VAX-11/730 systems 1 and 2 are now ready for acceptance testing (Chapter 8).

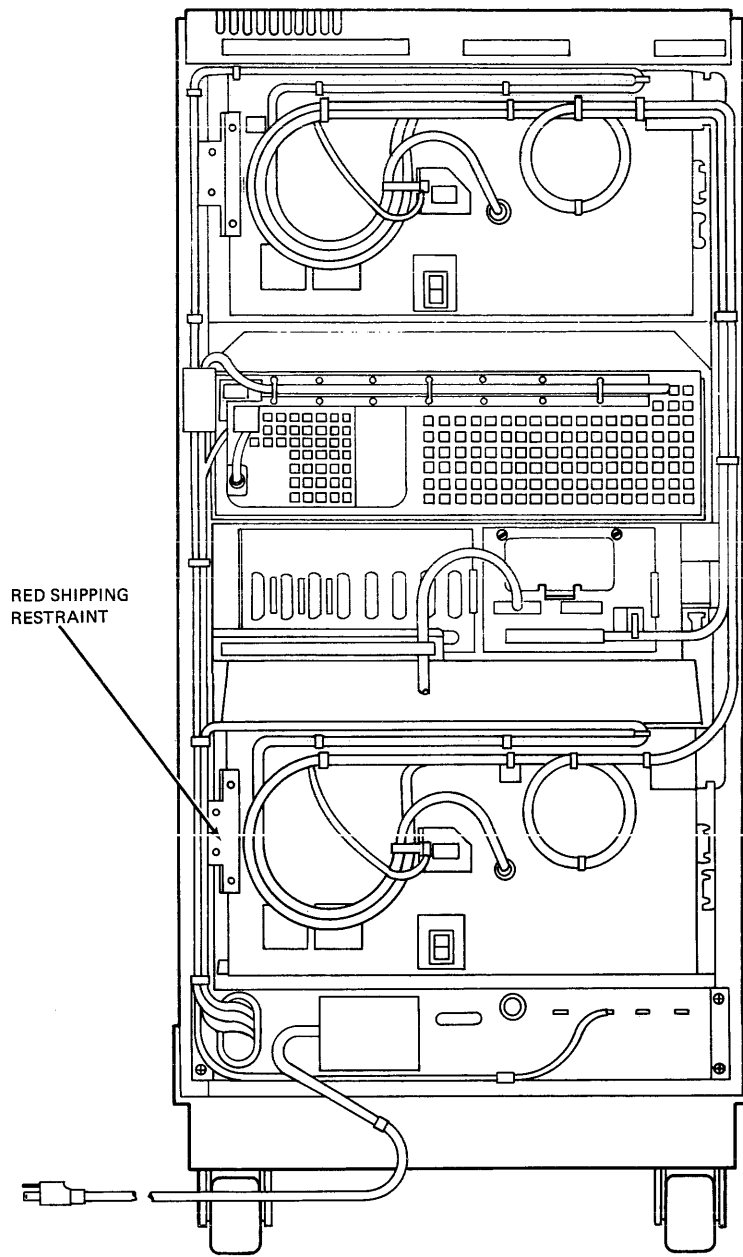

TK-11160

Figure 3-23 Rear of the System Cabinet Showing the RL02 Shipping Restraint

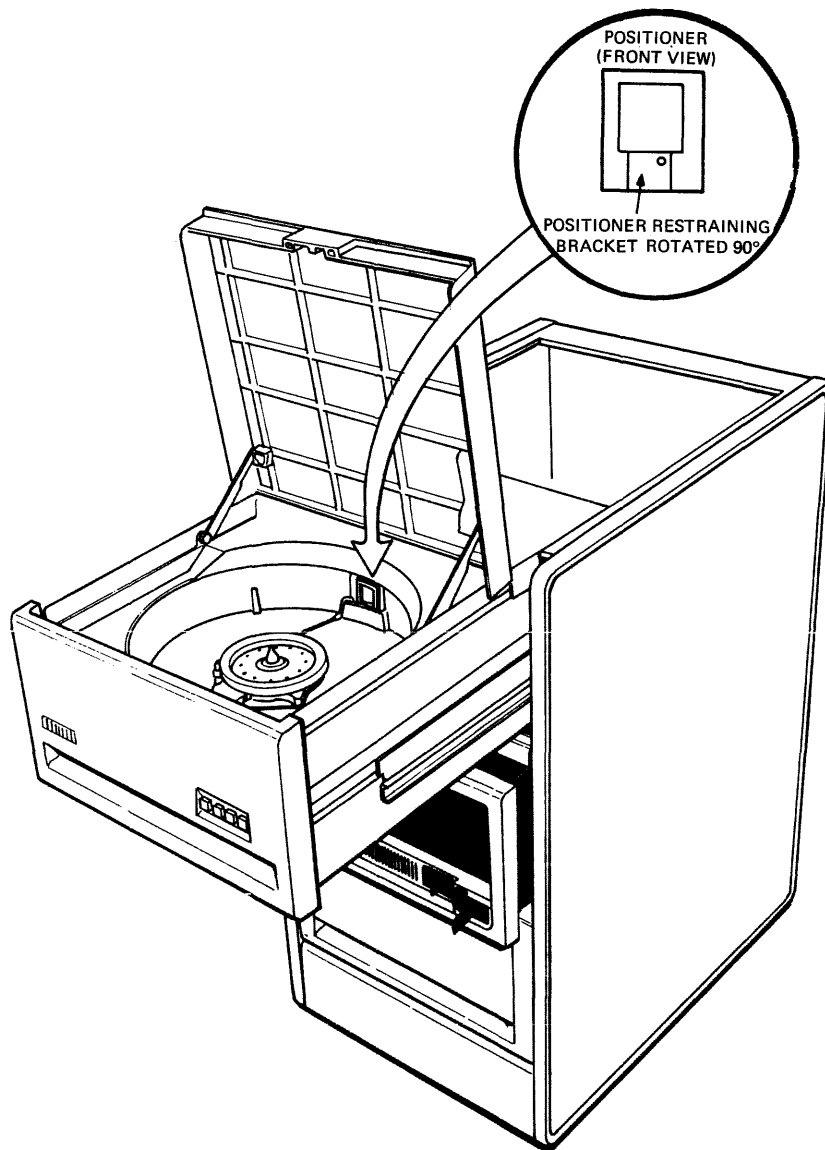

TK-8382

Figure 3-24 RL02 Head Disk Assembly Exposed

CHAPTER 4

VAX-11/730 SBB HARDWARE INSTALLATION

4.1 GENERAL

This chapter provides step-by-step procedures for the following:

- System cabinet installation
- Drive device cabinet installation
- UNIBUS expander cabinet installation (H9642-FA/FB/FC/FD)
- Cabling check
- Device preparation prior to power-up
- AC power check
- System power-up

NOTE

In this chapter RIGHT and LEFT refer to side directions when facing the front of the cabinet.

4.2 VAX-11/730 SBB SYSTEM CONFIGURATION GUIDELINES

When installing the VAX-11/730 SBB system, observe the following guidelines on system configuration:

1. The VAX-11/730 SBB system cabinet is always the leftmost cabinet in the string of physically joined cabinets.
2. The UNIBUS expander cabinet is physically joined to the system cabinet.
3. Drive device cabinets are not attached to other cabinets, except in the case where a disk drive is included in the expander cabinet.

4.3 VAX-11/730 SBB CABINET INSTALLATION

This section covers the cabinet installation of the system, drive device and expander cabinets. This installation includes joining the expander cabinet to the system cabinet.

4.3.1 System Cabinet Installation

The system cabinet can be positioned alone, positioned adjacent to the drive device cabinet, or attached to the UNIBUS expander cabinet. To install the system cabinet, perform the following steps:

1. Roll the system cabinet into the installation position.
2. Adjust the leveler feet (Figure 4-1) on the cabinet for contact with the floor and tighten the hex nut on each foot. Adjust the leveler foot on the stabilizer arm, in the extended position, for contact with the floor.
3. Installation of the terminal and peripheral devices (expander cabinet, drive device cabinets, printer, console terminal, etc.) should be done at this time.

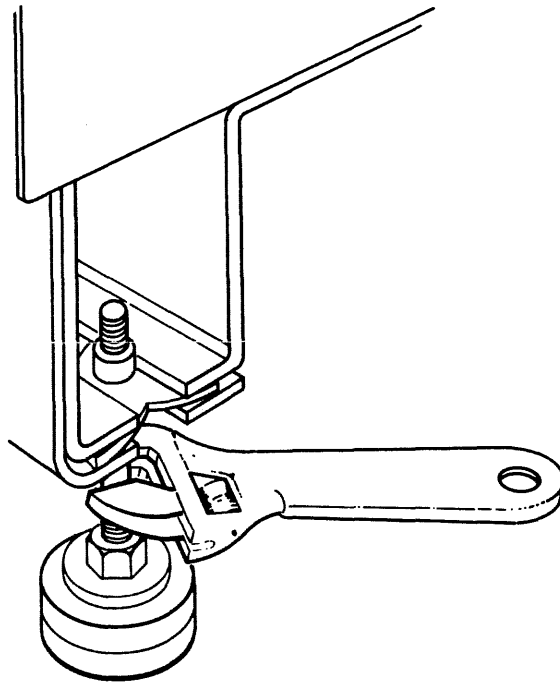

TK-11147

Figure 4-1 Leveler Feet Adjustment

4.3.2 UNIBUS Expander Cabinet Installation

If a UNIBUS expander cabinet is included in the system configuration, perform the following steps to join the expander cabinet to the system cabinet.

1. Roll the expander cabinet into the installation position (close to the system cabinet).
2. Remove the system and expander cabinet front door by performing the following steps (Figure 4-2):
 - a. Use a 5/32-inch hex wrench to release the quarter-turn door fastener.
 - b. Disconnect the door-to-cabinet frame ground wire.
 - c. Slide the retractable hinge pin (at the door top) down until the top of the door is released.
 - d. Tilt the top of the door away from the cabinet and lift the door until the lower hinge pin is removed from the hole in the lower door bracket.
3. Remove the system and expander cabinet rear door by performing the steps below (Figure 4-3):
 - a. Use a 5/32-inch hex wrench to release the two quarter-turn door fasteners.
 - b. Tilt the top of the door away from the cabinet and lift the door until the lower hinge pins are removed from the holes in the right and left door brackets.
4. Remove the right-end panel from the system cabinet by grasping the panel by the front and rear ends, and lifting the panel approximately 1 inch (Figure 4-4).
5. Remove the cabinet joiner panel from the expander cabinet left side, by grasping the panel by the front and rear ends and lifting the panel approximately 1 inch (Figure 4-5).
6. Remove the four leveler feet and leveler nuts from the cable trough/stabilizer bar kit (Figure 4-6), assemble them. Then, install them into the base corners on the expansion cabinet (Figure 4-7).
7. Remove the shielding insert from the right side of the system cabinet and left side of the expander cabinet by removing the four key buttons and two mounting screws, and lifting the inserts up and out, as shown in Figures 4-8 and 4-9.

CAUTION

When handling the shielding inserts avoid damaging the copper-beryllium finger stock on the edges of the inserts.

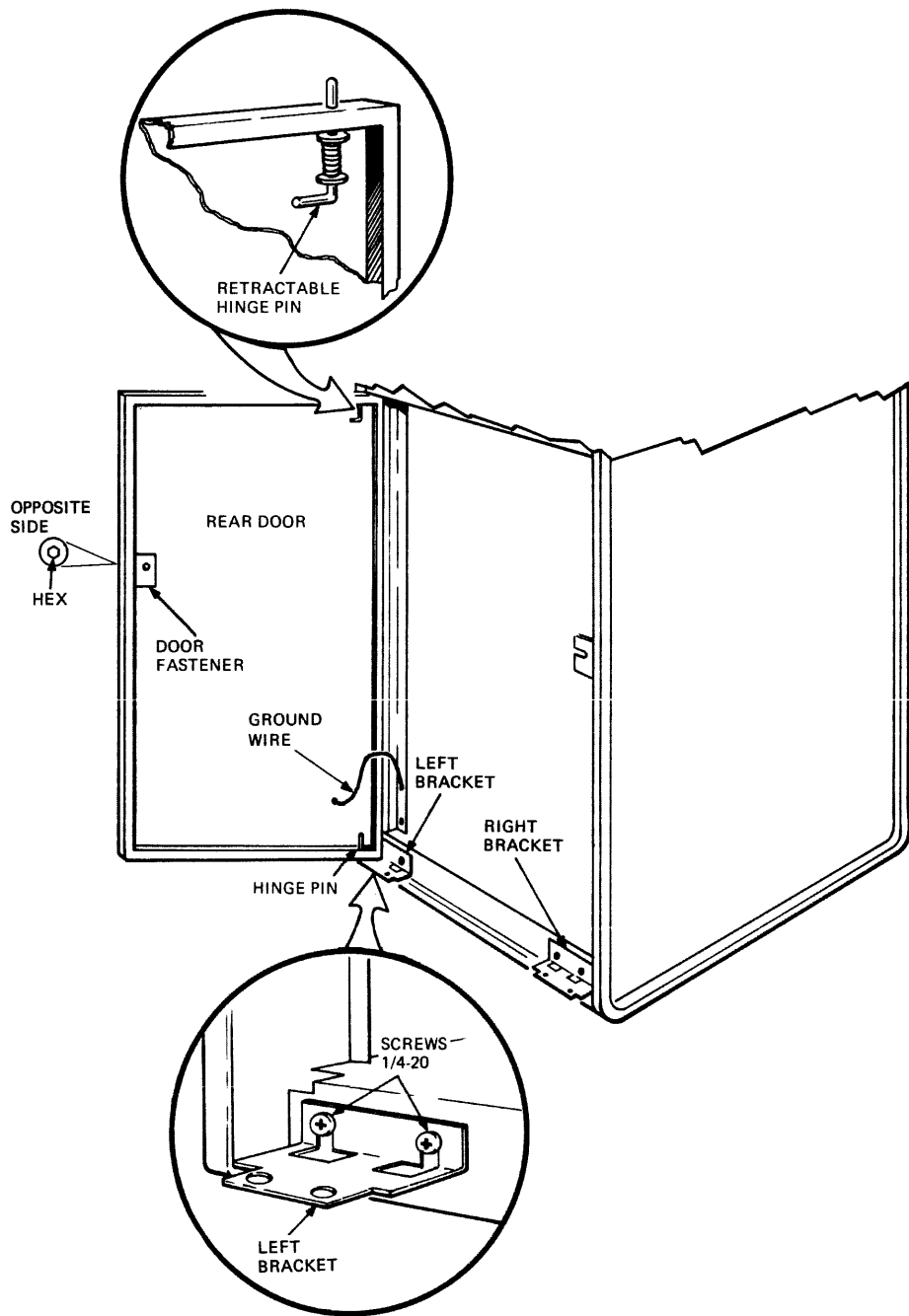

TK-11181

Figure 4-2 System and Expander Cabinet Front Door Removal and Replacement

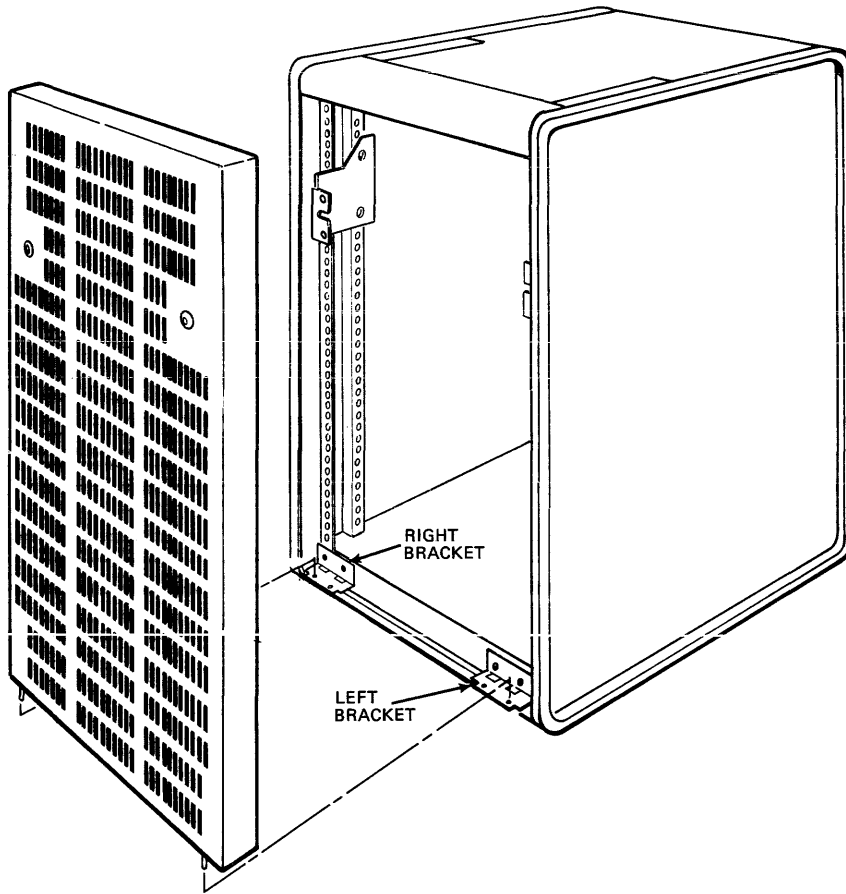

TK-11162

Figure 4-3 System and Expander Cabinet Rear Door Removal and Replacement

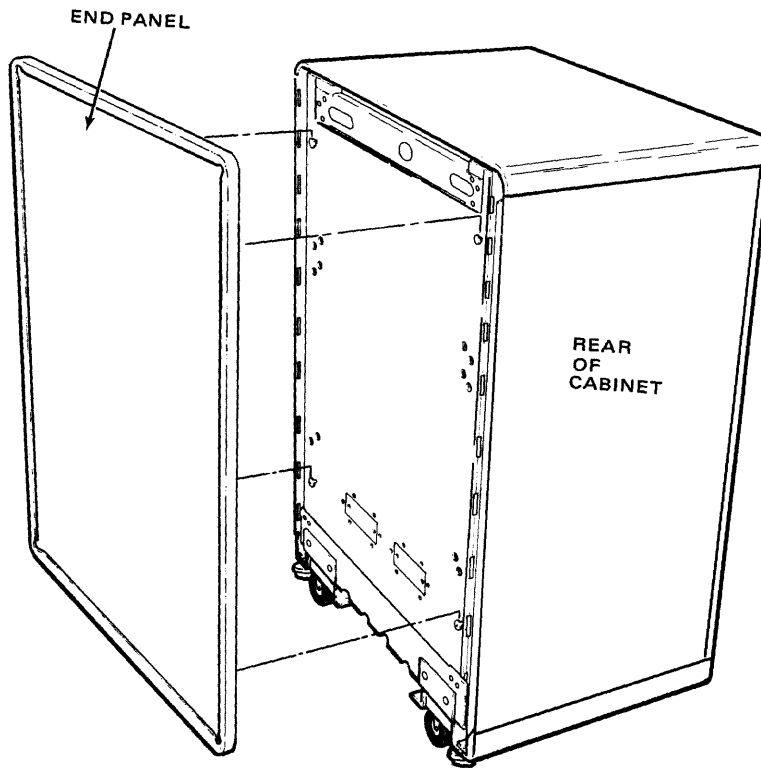

TK-11163

Figure 4-4 Cabinet End Panel Removal

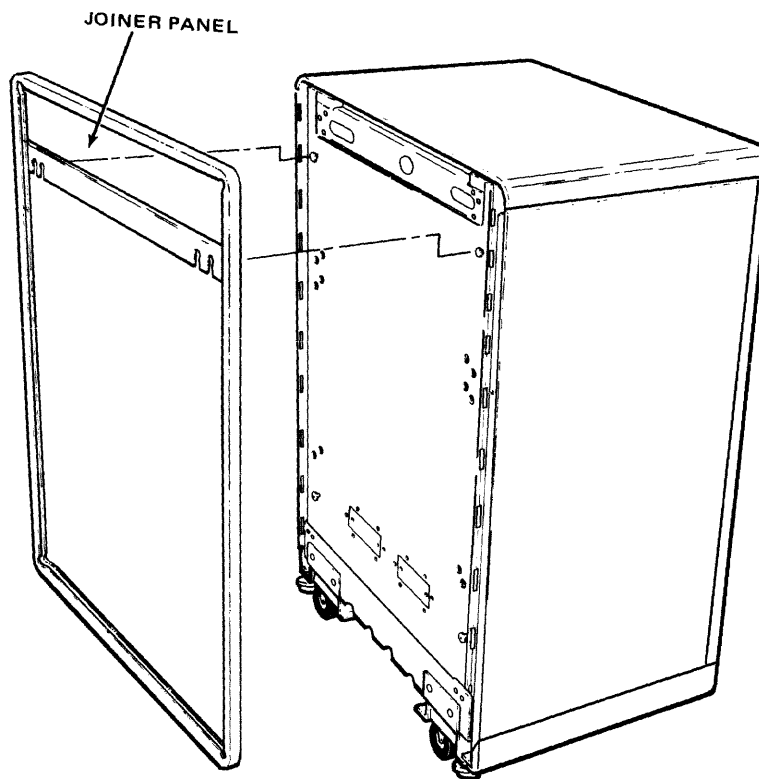

TK-11164

Figure 4-5 Cabinet Joiner Panel Removal

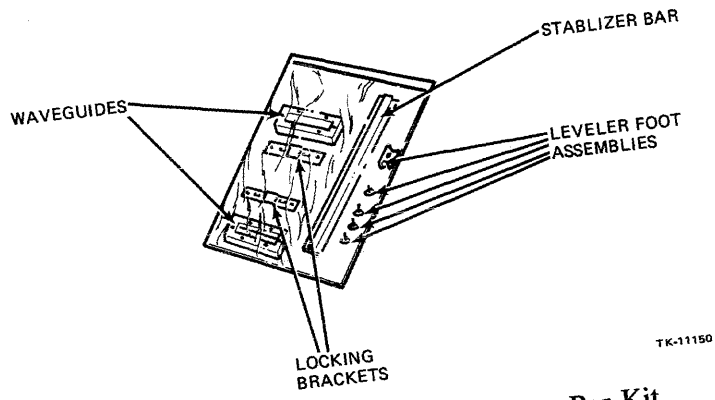

Figure 4-6 Cable Trough/Stabilizer Bar Kit

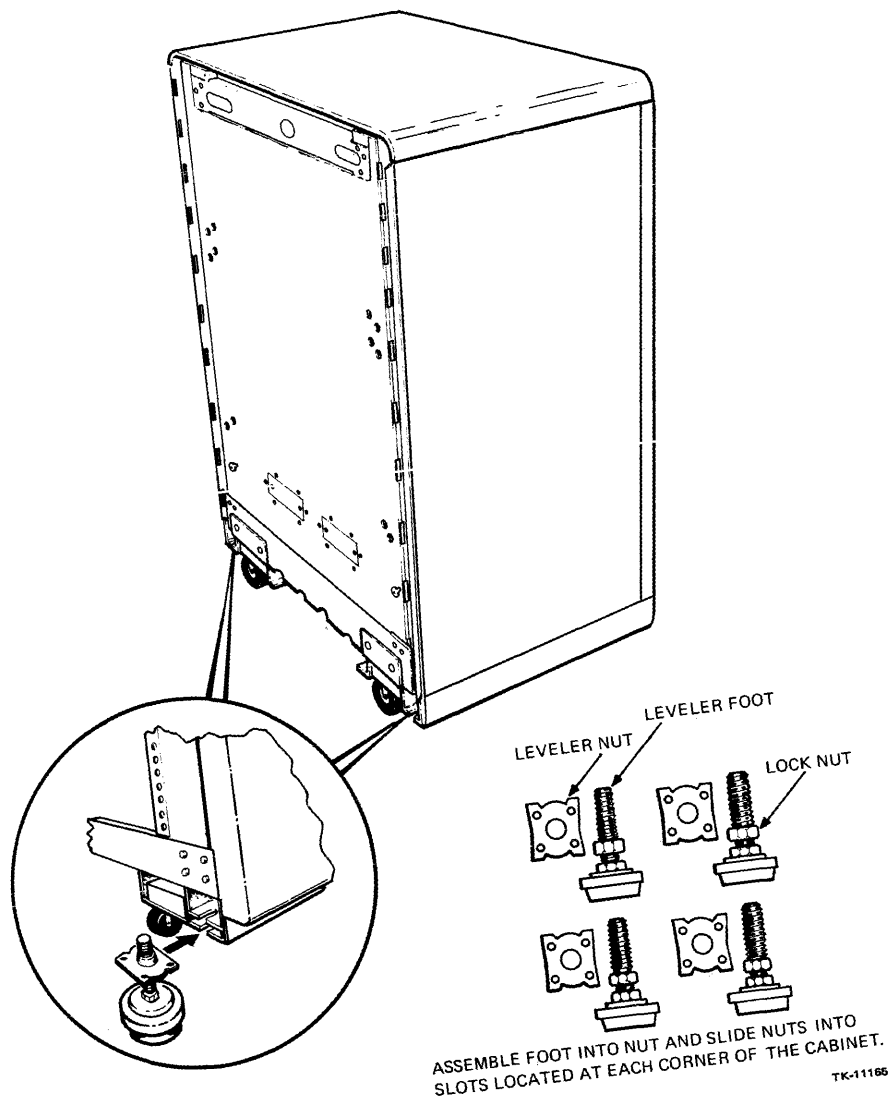
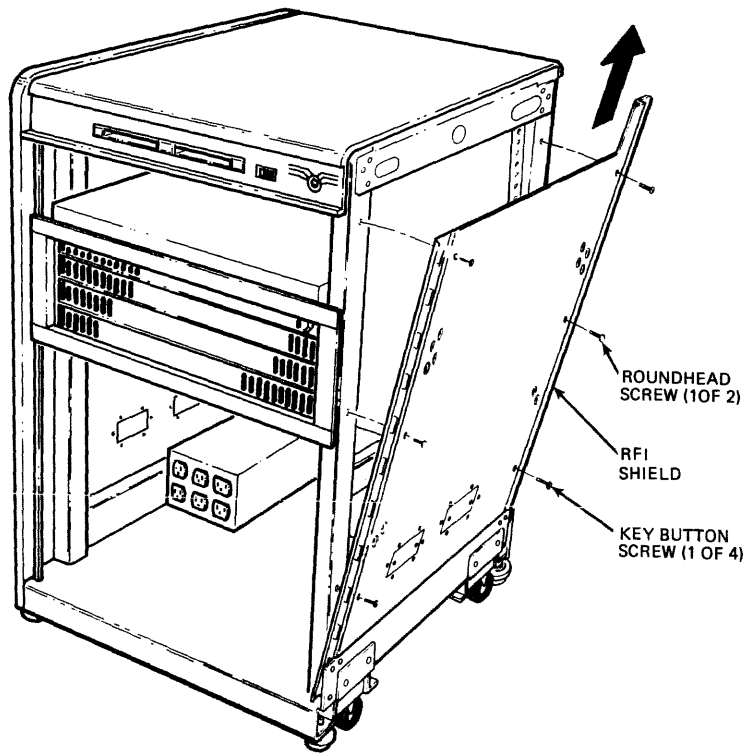
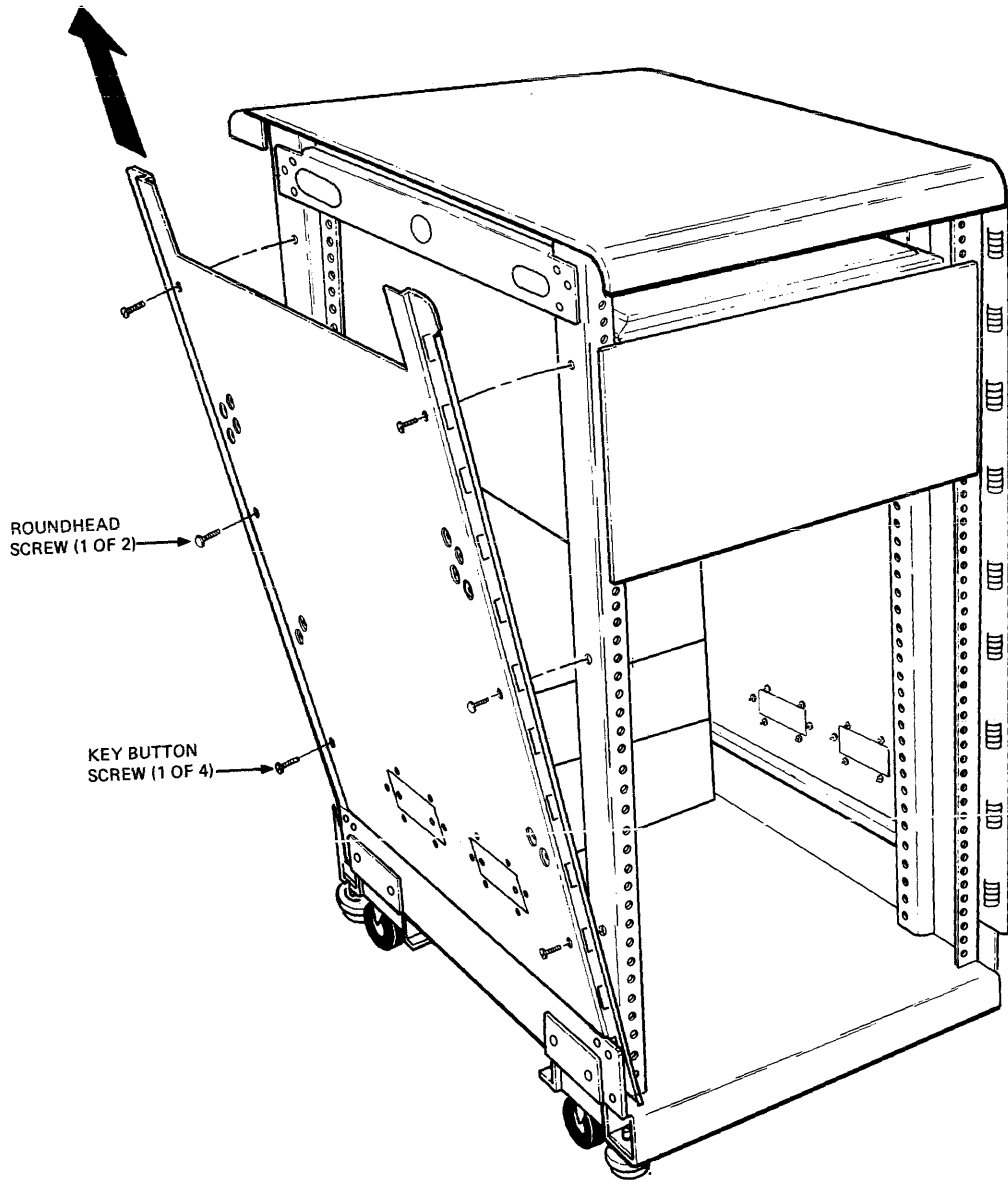

Figure 4-7 Leveler Feet Assembly and Installation



TK-11166

Figure 4-8 Shielding Insert Removal from the System Cabinet



TK-11167

Figure 4-9 Shielding Insert Removal from the Expander Cabinet

8. Lay the shielding inserts down with the knockout end supported and use a screwdriver and hammer to remove the front knockouts from the system and expander inserts (Figure 4-10).

NOTE

If more than one knockout is removed, ensure that a cable trough is installed over both knockout holes. If a knockout is removed and the hole is not covered, the cabinet is no longer FCC compliant.

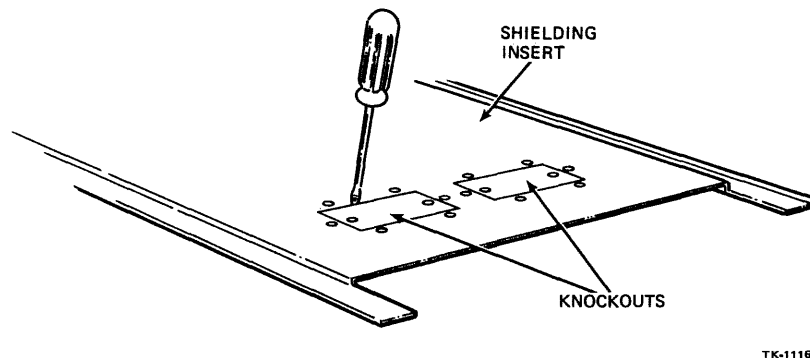

Figure 4-10 Knockout Removal from the Shielding Insert

9. Remove a cable trough and 12 mounting screws from the cable trough/stabilizer bar kit (Figure 4-6).
10. Mount a cable trough on the outside of the expander cabinet shielding insert using the six screws supplied (Figure 4-11).
11. Mount the inserts on the system and expander cabinet by performing the following steps (Figures 4-8 and 4-9):
 - a. Tilt the top of the insert away from the cabinet and place its bottom behind the horizontal support on the cabinet bottom.
 - b. Push the insert top against the cabinet frame and install the key buttons and screw removed in step 7.

NOTE

If the inserts bind during mounting, remove them and start the mounting procedure again at step 11a.

12. Loosely install the joiner panel on the right side of the system cabinet.
13. Raise the joiner panel on the system approximately 1 inch and position the expander cabinet against the system cabinet (Figure 4-12).
14. Adjust the expander cabinet leveler feet to obtain alignment of the cable trough and the knockout hole on the system cabinet insert.

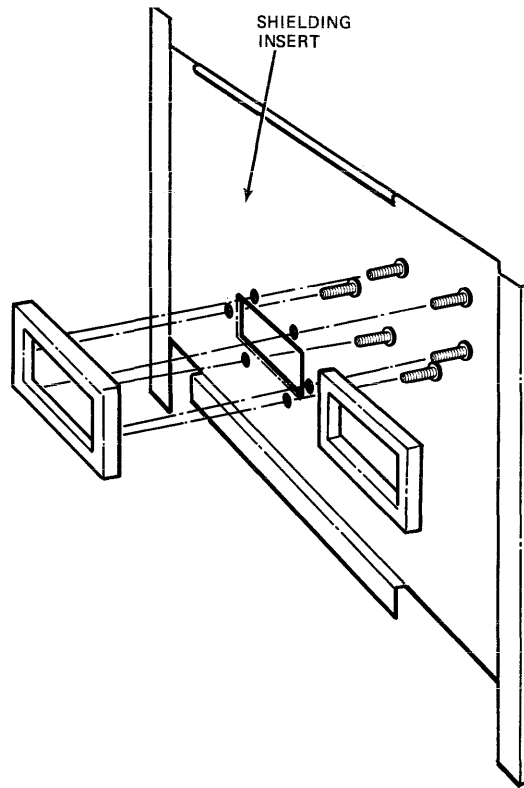

TK-11169

Figure 4-11 Mounting the Cable Trough to the Shielding Insert

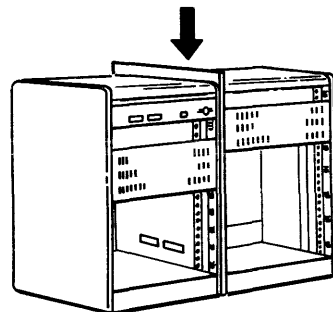
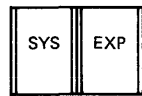
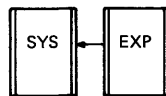

TK-11170

Figure 4-12 Joining the System and Expander Cabinets

15. Push the joiner panel down engaging the key buttons on the system and expander cabinets into the slots on the joiner panel (Figure 4-12).
16. Mount the cable trough to the system cabinet shielding insert with six mounting screws.
17. Bolt the cabinets together at the bottom front and rear by removing the screws from the system and expander cabinets door brackets, then sliding the interconnecting bar behind the front edge of the joiner panel and over the door brackets, as shown in Figure 4-13. Install the bracket screws and tighten.
18. Install the right end panel on the expander cabinet that was removed from the system cabinet in step 4.

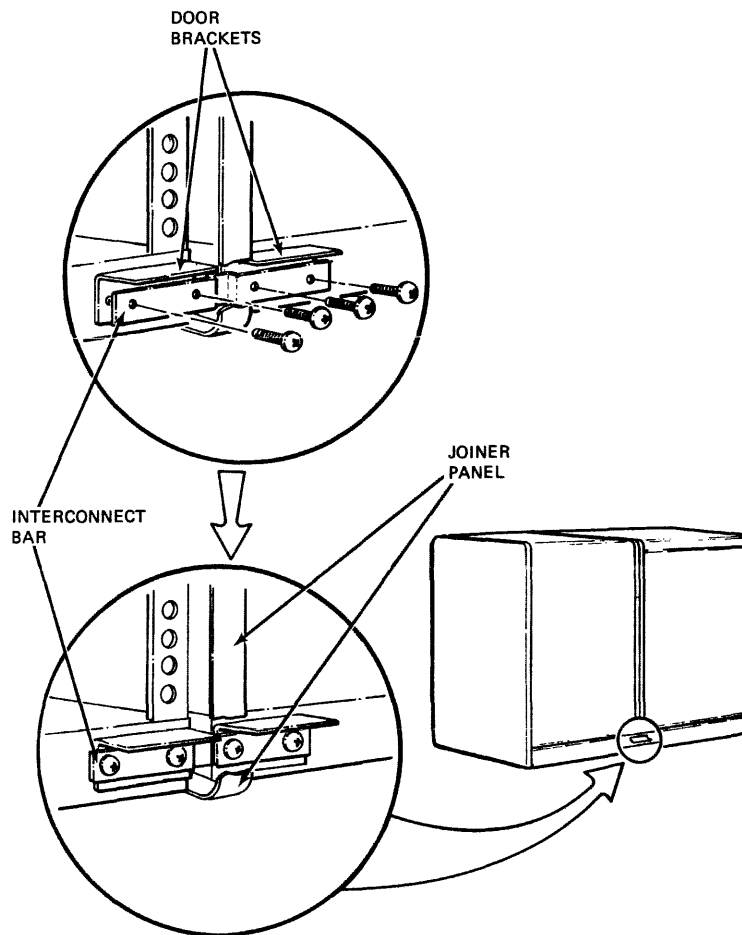

TK-11171

Figure 4-13 Bolting the Joined Cabinets Together

19. Install the stabilizer bar into the expansion cabinet by performing the following steps (Figure 4-14):
 - a. Remove the stabilizer bar and leveler foot from the cable trough/stabilizer bar kit (Figure 4-6).
 - b. Screw the leveler foot into the stabilizer bar.
 - c. Insert the stabilizer bar, foot first, into the channel located at the bottom rear of the cabinet.
 - d. Remove the retaining cable and screw from the back of the cabinet base and attach it to the underside of the stabilizer bar.

NOTE

The retaining cable is used to limit the forward extension of the stabilizer bar.

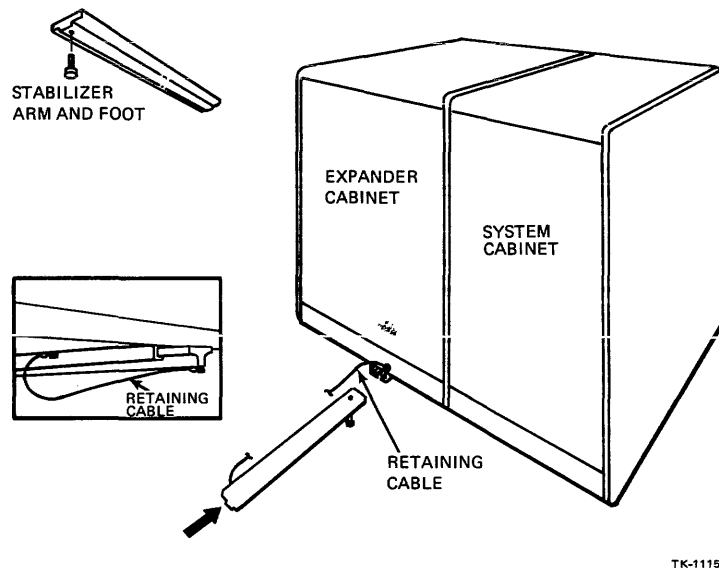

Figure 4-14 Stabilizer Bar Installation (Rear View)

4.4 DRIVE DEVICE CABINET PREPARATION

Install the drive device cabinet as described in the documentation shipped with the equipment.

NOTE

The leveler feet on the drive device cabinet must be adjusted to assure the cabinet is level.

4.5 CONSOLE TERMINAL

Install the console terminal as described in the documentation shipped with the equipment.

4.6 VAX-11/730 SBB DEVICE PREPARATION

Some system devices must be checked and/or prepared prior to system power-up. Device preparation is described in the following paragraphs.

CAUTION

Ensure that the stabilizer bar on the system cabinet is in the extended position to prevent tipping of the cabinet when the mounting box is extended.

4.6.1 CPU Mounting Box (BA11-AS/AT)

Prepare the mounting box by performing the following steps:

1. Remove the CPU mounting box shipping restraint from the left rear of the system cabinet (Figure 4-15).
2. Slide the release latch, on the front of the CPU mounting box, to the left and withdraw the box from the cabinet (Figure 4-16).
3. Remove the four mounting screws that hold the top cover to the mounting box, then remove the cover assembly (Figure 4-17).
4. Assure modules are firmly seated into backplane.

4.6.2 Cabling Check

Ensure that all system cabinet cabling is free of damage and properly connected on the following:

- The CPU DEC POWER CONTROL BUS cable connected to the power supply at the rear of the mounting box must be connected to one of the two DEC POWER CONTROL BUS connectors on the front of the power controller. The ac power cord must be connected to a switched outlet on the front of the power controller.
- The Battery Backup Unit (BBU) DEC POWER CONTROL BUS cable must be connected to one of the two DEC POWER CONTROL BUS connectors on the front of the power controller. The BBU power cord must be connected to an unswitched outlet on the front of the power controller.
- The drive and expander cabinet power controller DEC POWER CONTROL BUS cable is connected to one of the two DEC POWER CONTROL BUS connectors on the rear of the system cabinet power controller.
- The TU58, CONSOLE and R/D cables connected to the WCS module (slot 7) in the mounting box must be connected to the TU58 tape drive in the top of the cabinet and CONSOLE and R/D ports on system I/O panel at the rear of the cabinet.
- All CPU mounting box option cables are connected to the modules and the associated I/O panels as defined in the option documentation shipped with the system.
- All power and data cables in the drive device cabinet are connected as specified in the documentation shipped with the equipment.

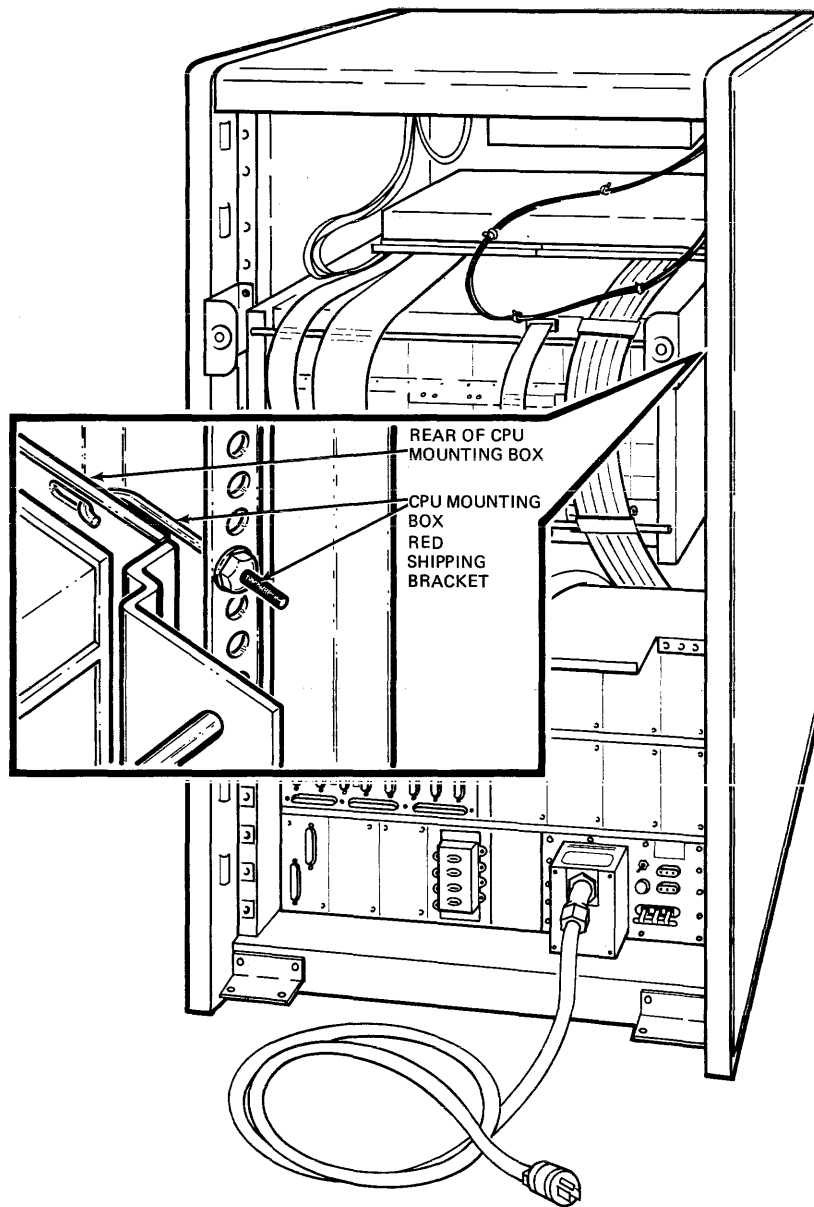

TK-11172

Figure 4-15 CPU Mounting Box Shipping Restraint

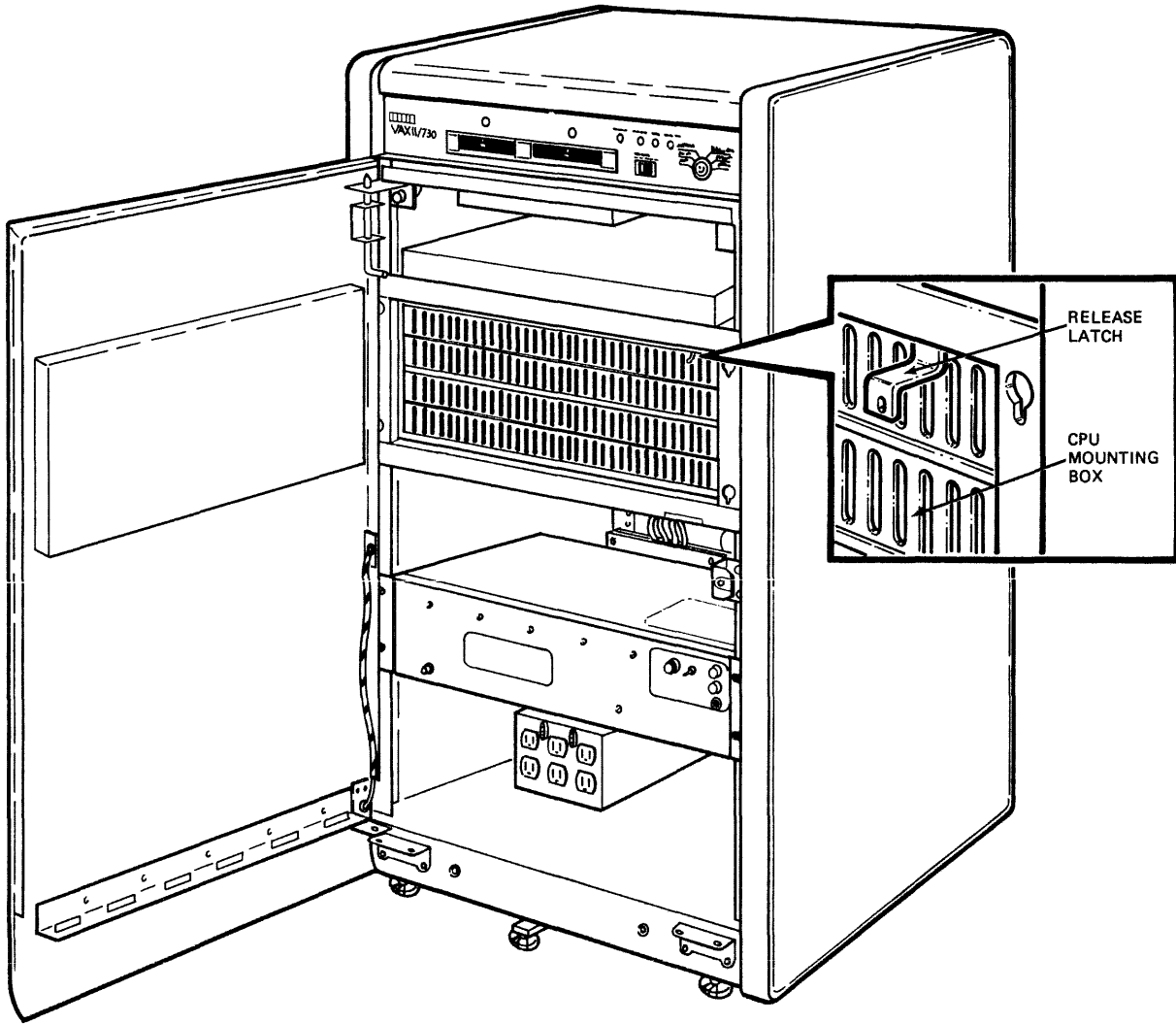

TK-11173

Figure 4-16 CPU Mounting Box Release Latch

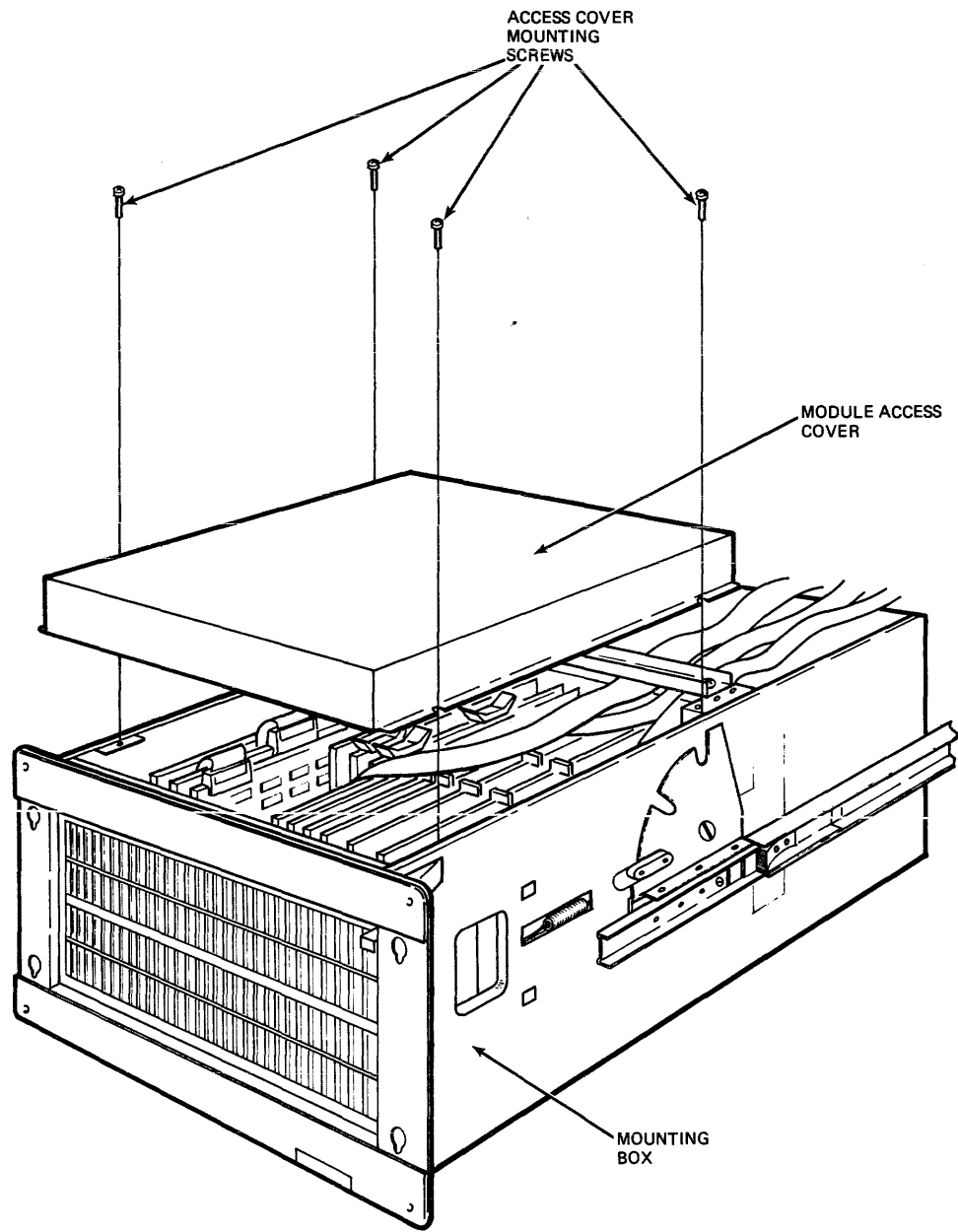

TK-11174

Figure 4-17 Top Cover Assembly Removal

4.6.3 Console Terminal

Prepare the console terminal as specified in the documentation shipped with the equipment.

4.6.4 Drive Devices

Prepare the RA60, RA81, RA80 and TU80 drive devices as specified in the drive user documentation shipped with the equipment.

4.6.5 WCS Module (Switch Settings)

Follow the procedure below to set up the terminal baud rate on the WCS module:

1. Disconnect the three cables and remove the WCS module (M8394, Slot 7, Figure 4-18).
2. Locate the E47 switchpack on the module (Figure 4-19); then follow Table 4-1 for the switch settings corresponding to the appropriate baud rate.

No other rates are provided. The normal baud rate for the console terminal is 2400 baud.

3. Return the WCS module to slot 7 and reconnect the three cables.

1	UNUSED			
2	M8389	FPA		
3	UNUSED			
4	M8390	DAP		
5	UNUSED			
6	M8391	MCT		
7	M8394	WCS		
8	M8750 MS730CA			730-A CPU BACKPLANE
9	M8750 MS730CA			
10	M8750 MS730CA	G7273		
11	UNUSED	G7273		
12	UNUSED	G7273		
13	UNIBUS	G7273	SPC	
14	M9202 UNIBUS JUMPER CABLE	G7273	SPC	
1			G727	
2	UNIBUS		G727	
3	UNIBUS		G727	
4	UNIBUS		G727	DD11-DK EXPANDER BACKPLANE
5	UNIBUS		G727	
6	UNIBUS		G727	
7	UNIBUS		G727	
8	UNIBUS		G727	
9	M9302 TERMIN UNIBUS		G727	

TK-11175

Figure 4-18 Module Location Chart

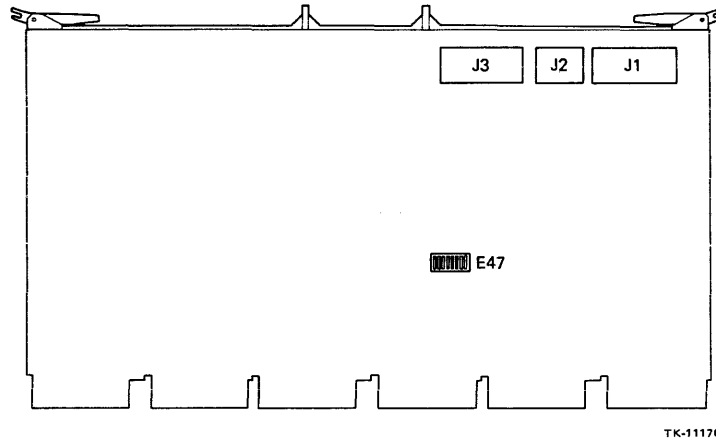
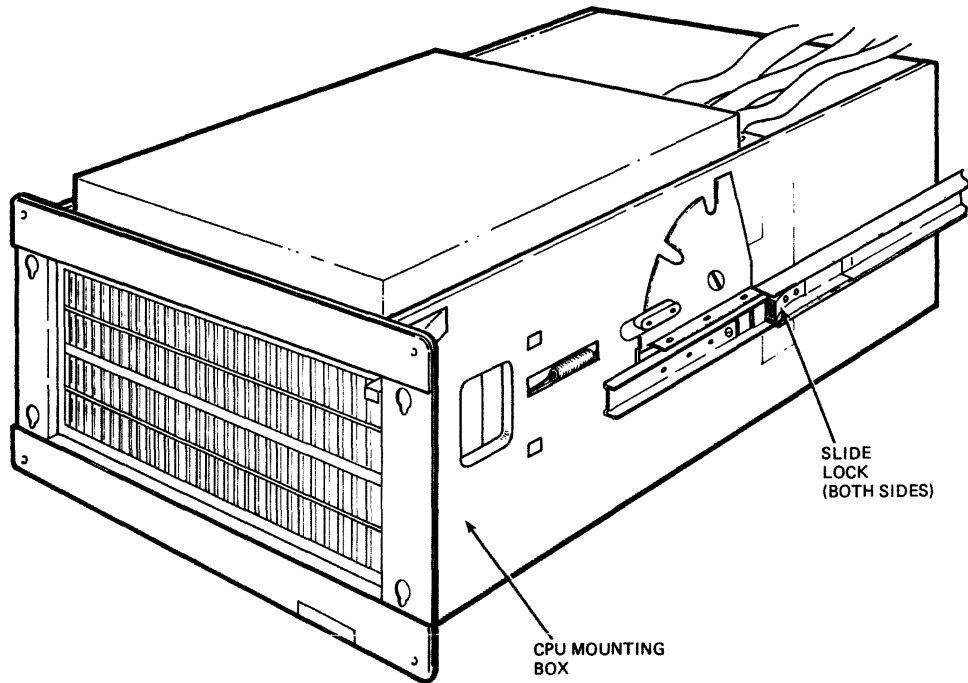

Figure 4-19 Switchpack and Connector Locations on the WCS Module

Table 4-1 The WCS Module E47 Switchpack Switch Settings and Corresponding Console Baud Rates

Switch	Console Baud Rate
E47-3 OFF E47-4 OFF	9600
E47-3 OFF E47-4 ON	2400
E47-3 ON E47-4 OFF	1200
E47-3 ON E47-4 ON	300

4. Release the mounting box slide locks (Figure 4-20) and slide the box into the cabinet.
5. Replace the top cover assembly and install and tighten the four mounting screws.



TK-11177

Figure 4-20 CPU Mounting Box Slide Locks

4.7 VAX-11/730 SBB SYSTEM POWER-UP PROCEDURE

Perform the following steps to properly apply ac power to the system cabinet:

1. Ensure that the voltage/power requirements on the input power label (Figure 4-21) of the ac power controller is the same as the ac power.
2. Ensure that the voltage on the input power label (Figure 4-21) of the CPU mounting box is the same as the ac power.
3. Set the ac power controller power control switch to the REMOTE ON position.
4. Connect the ac power controller power cord to the facility ac power.
5. Set the CPU box circuit breaker on the rear of the mounting box to the 1 (ON) position.

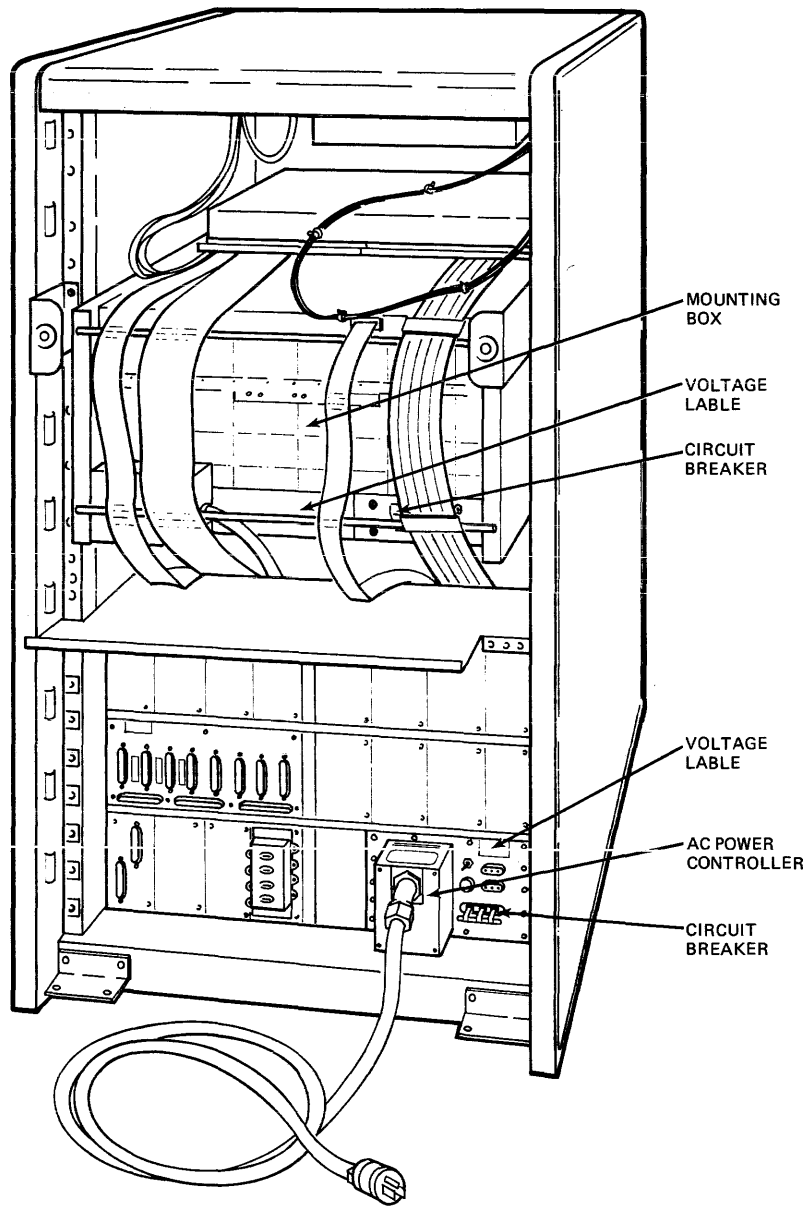

TK-11178

Figure 4-21 Rear View of System Cabinet Showing Device Voltage Labels and Circuit Breaker Locations

6. Install the front door onto the system and expander cabinets by performing the following steps (Figure 4-2):
 - a. Reconnect the door-to-cabinet frame ground wire.
 - b. Tilt the door and insert the lower hinge pin into the lower door bracket.
 - c. Move the top of the door toward its mounting position while holding the retractable hinge pin down.
 - d. Release the retractable pin when the pin is aligned with the hole in the top of the cabinet.
 - e. Ensure that all cabling is out of the way, and close the rear door.
 - f. Tighten the hex head quarter-turn door fastener to secure the door.
7. Install the rear door onto the system and expander cabinets by performing the steps below (Figure 4-3):
 - a. Tilt the rear door and insert the hinge pins into the right and left door brackets.
 - b. Ensure that all cabling is out of the way, then push the rear door into the cabinet.
 - c. Tighten the two hex head quarter-turn door fasteners to secure the door.
8. Perform the following steps to apply ac power to other cabinets in the system configuration:
 - a. Ensure that voltage labels and/or voltage switches on all equipment in other cabinets match the facility's ac power.
 - b. Set all cabinet equipment function switches and circuit breakers to OFF.
 - c. Connect the cabinet's power controller ac cord to the facility's ac power.
 - d. Set the circuit breaker on the cabinet power controller to ON.
 - e. Set the device's circuit breaker to ON.

The VAX-11/730 SBB system is now ready for acceptance testing (Chapter 8).

CHAPTER 5

VAX-11/730-ZA OEM BOX INSTALLATION

5.1 GENERAL

This chapter discusses the appropriate way to transport the equipment from the receiving area to the installation area and provides step-by-step procedures for shipment inventory, and unpacking the OEM box.

5.2 BOXED EQUIPMENT

The VAX-11/730-ZA is packed in a box and mounted to a shipping skid by hold-down straps. Fork lifts and mobile lifters can be used to move the packaged equipment.

NOTE

Information on moving equipment, shipment inventory, and unpacking boxes is contained in Chapter 2 of this document. Review this chapter before proceeding to the next paragraph.

5.3 UNPACKING THE VAX-11/730-ZA OEM BOX

Perform the steps below to unpack the OEM box (refer to Figure 5-1).

1. Cut the polyester straps.
2. Remove the cap, packaging material, and polyethylene bag that enclose the OEM box.
3. Lift the OEM box out of the shipping box and gently set it down ensuring that no cables are underneath the box.

WARNING

EXTREME CARE SHOULD BE TAKEN; the OEM box weighs in excess of 100 pounds. Two people should lift the box.

4. Remove the CPU cable retractor tray, cabinet slides, and miscellaneous hardware from the shipping box.

5.4 HARDWARE INSTALLATION

The OEM box is mounted in a 19-inch cabinet (Figure 5-2). This requires preinstallation planning for placement of the box in the cabinet. For preinstallation and installation of the OEM box, follow the paragraphs below in the order that they are presented.

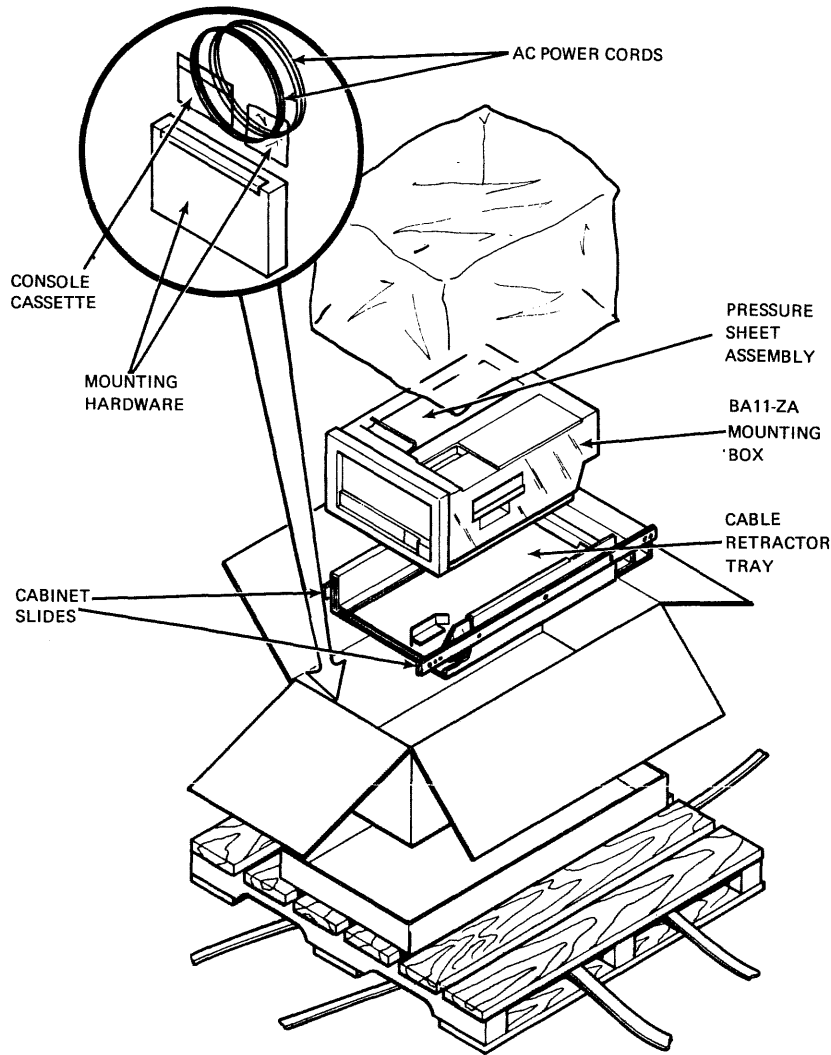

TK-8594

Figure 5-1 Unpacking the VAX-11/730-ZA OEM Box

5.4.1 Cable Retractor Tray Assembly Installation

The cable retractor tray assembly is the first part of the VAX-11/730-ZA to be mounted in the 19-inch cabinet. Follow the steps below to mount the cable retractor assembly in a 19-inch cabinet.

NOTE

In the following paragraphs, hole numbers are referenced from the bottom hole in the window, which is hole number 1.

1. Ensure that the 10.5-inch window has been allotted in the cabinet, as illustrated in Figure 5-3. This window is equal to six RETMAs (18 holes).
2. Loosen the five screws in the bottom and the three screws in the bottom rear of the retractor tray, as well as three screws on the right side of the system I/O panel, then compress the tray horizontally (Figure 5-3).

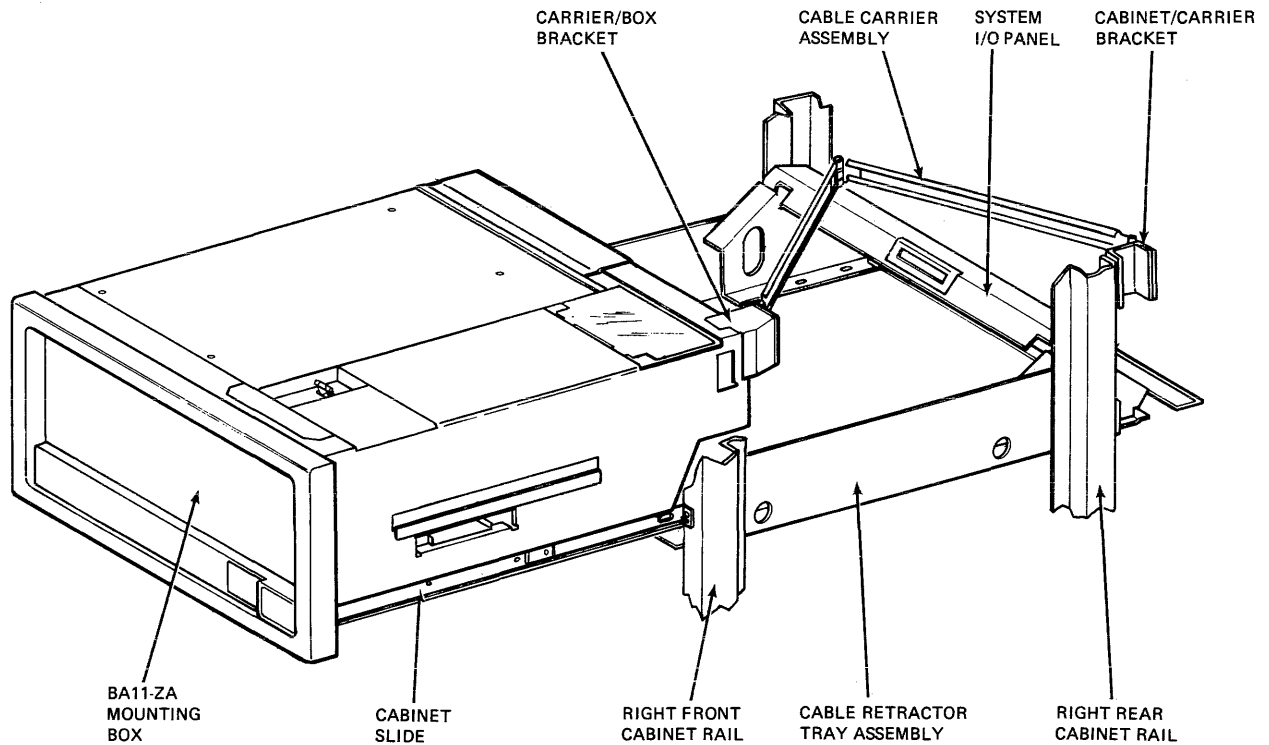

TK-8591

Figure 5-2 VAX-11/730-ZA OEM Box Mounted in a 19-Inch Cabinet

5.4.2 Cabinet Slide Assembly Installation

Install the cabinet slide assemblies by performing the following steps:

1. Place retainer U-nuts (a total of eight) over holes 3 and 4 on the right and left faces of the front and rear cabinet rails (Figure 5-3).
2. Attach the slide mounting brackets to the cabinet slides with the hardware supplied by performing the following steps (Figure 5-3).
 - a. Mount a right side slide mounting bracket securely to the front of the right cabinet slide.
 - b. Mount a left side slide mounting bracket loosely to the rear of the left cabinet slide.
 - c. Mount a left side slide mounting bracket securely to the front of the left cabinet slide.
 - d. Mount a right side slide mounting bracket loosely to the rear of the right cabinet slide.
3. Place the retractor tray in the cabinet, lining up the side keying holes with hole 8 on the four side rails.
4. Place the four stud plates into the sides of the tray and into holes 4 and 7 in the side rails, then secure them with the mounting hardware (Figure 5-3).
5. Tighten the five screws in the bottom and the three screws in the bottom rear of the retractor tray, as well as the three screws on the right side of the I/O panel.

S-4

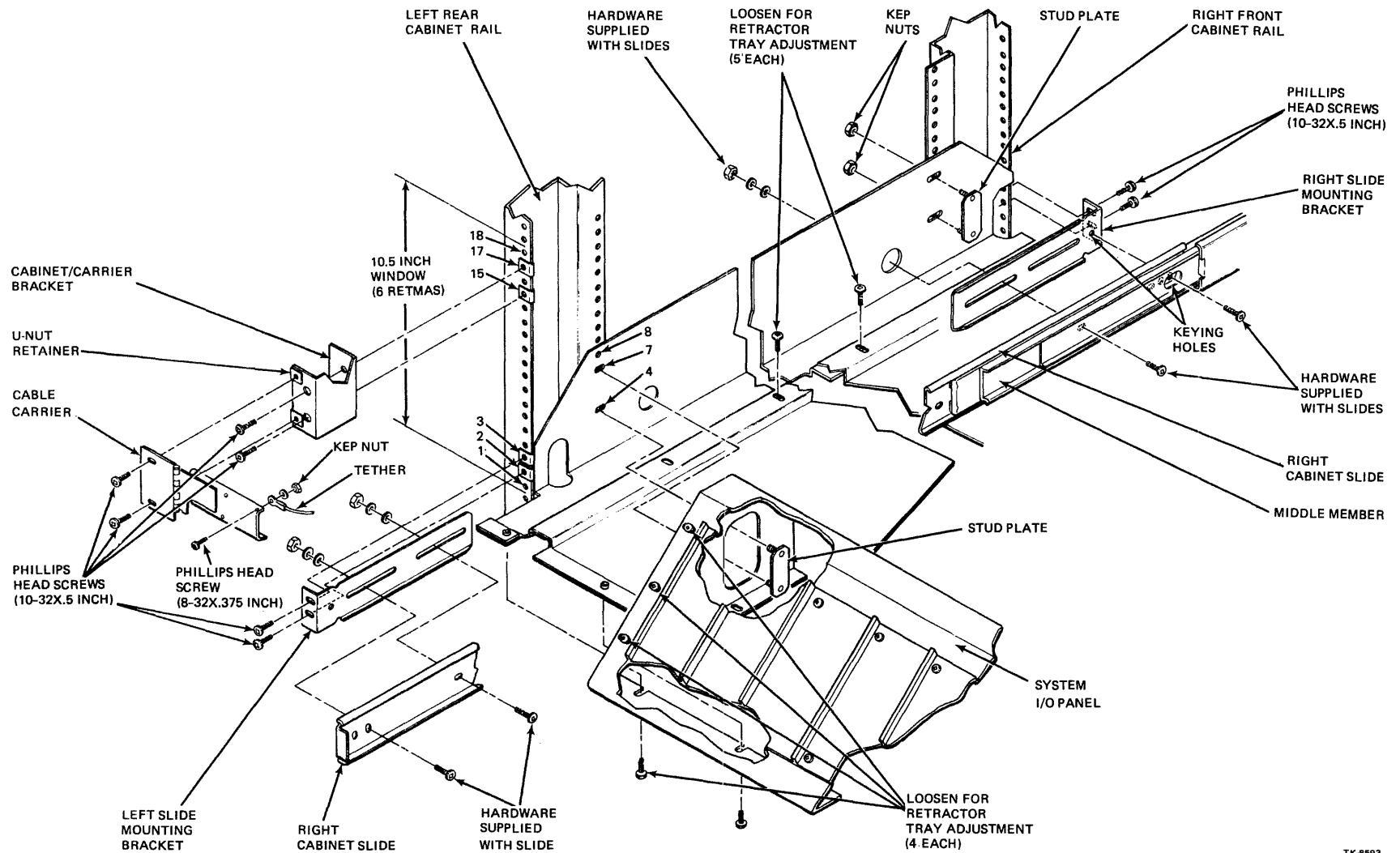

TK-8593

Figure 5-3 Mounting the Cabinet Retractor Tray and Cabinet Slides to the Cabinet

3. Place left and right cabinet sides in mounting position and size to fit cabinet, then tighten mounting hardware holding rear slide mounting brackets to cabinet slides (Figure 5-3).
4. Mount cabinet slides securely in the cabinet by installing two mounting screws in each of the front and rear slide mounting brackets and retainer U-nuts installed in step 1.

5.4.3 BA11-Z Mounting Box Installation

Install the BA11-Z mounting box on the cabinet slides by performing the following steps (Figure 5-4).

CAUTION

Before the BA11-Z mounting box is placed on the cabinet slides, ensure that the cabinet stabilizer is fully extended.

1. Extend the cabinet slides from the cabinet and set the BA11-Z mounting box onto the slides.
2. Raise the mounting box approximately 1/8 inch and install the slide to the box, mounting screws (four to a side). The middle slide member can be moved to provide access holes for slide mounting hardware.
3. Route cabling from the catch pan assembly to the cable retractor tray assembly, as described in Chapter 6.

5.4.4 Cable Carrier Assembly Installation

Mount the cable carrier assembly to the rear of the mounting box and rear of the cabinet by performing the following steps.

1. Mount the carrier/box bracket to the right rear of the mounting box (Figure 5-5).
2. Place two retainer nuts over holes 15 and 17 on the right rear of the cabinet frame (Figure 5-3).
3. Mount the cabinet/carrier bracket to the right rear of the cabinet frame into the retainer nuts (Figure 5-3).
4. Mount the cable carrier to the carrier/box and the cabinet/carrier brackets.
5. Connect the appropriate power cord (either the 120 Vac or 240 Vac) to the power supply in the mounting box.
6. Route and tie-wrap the power cord around the cable carrier, then down the right rear of the cabinet.
7. Attach the service interlock tether to the cable carrier (Figures 5-5 and 5-3).

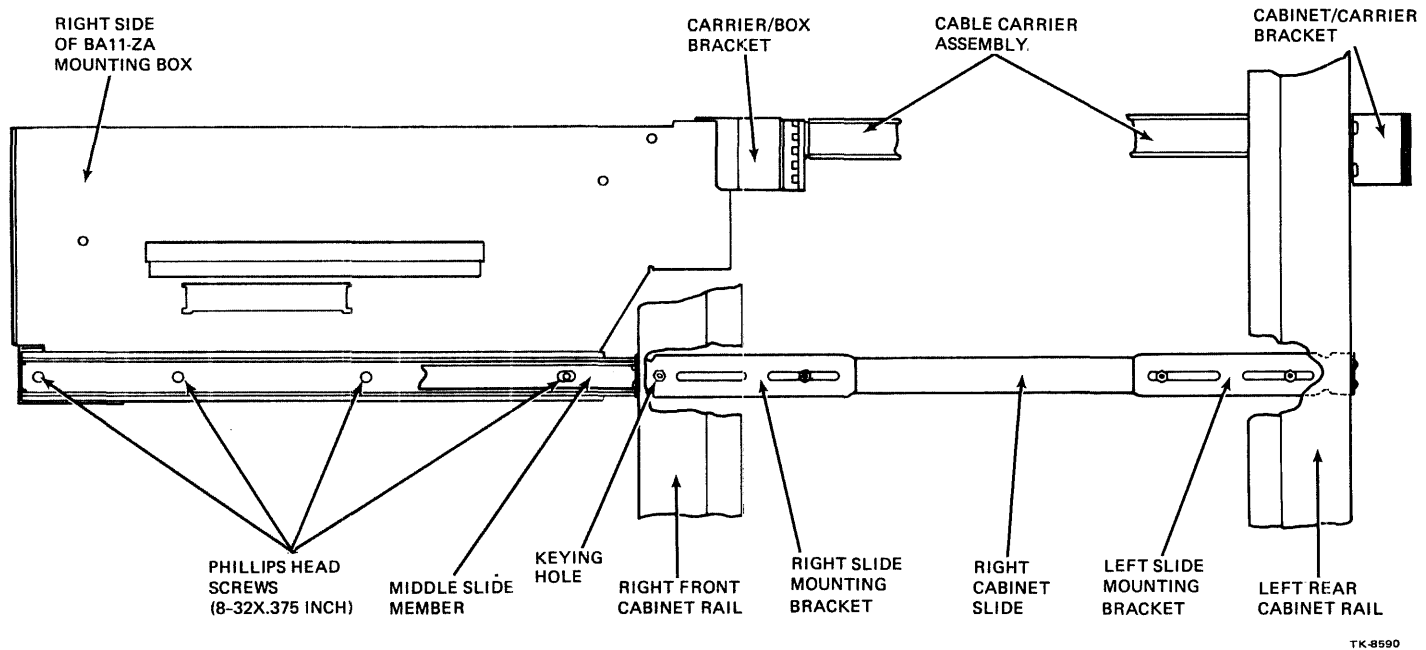
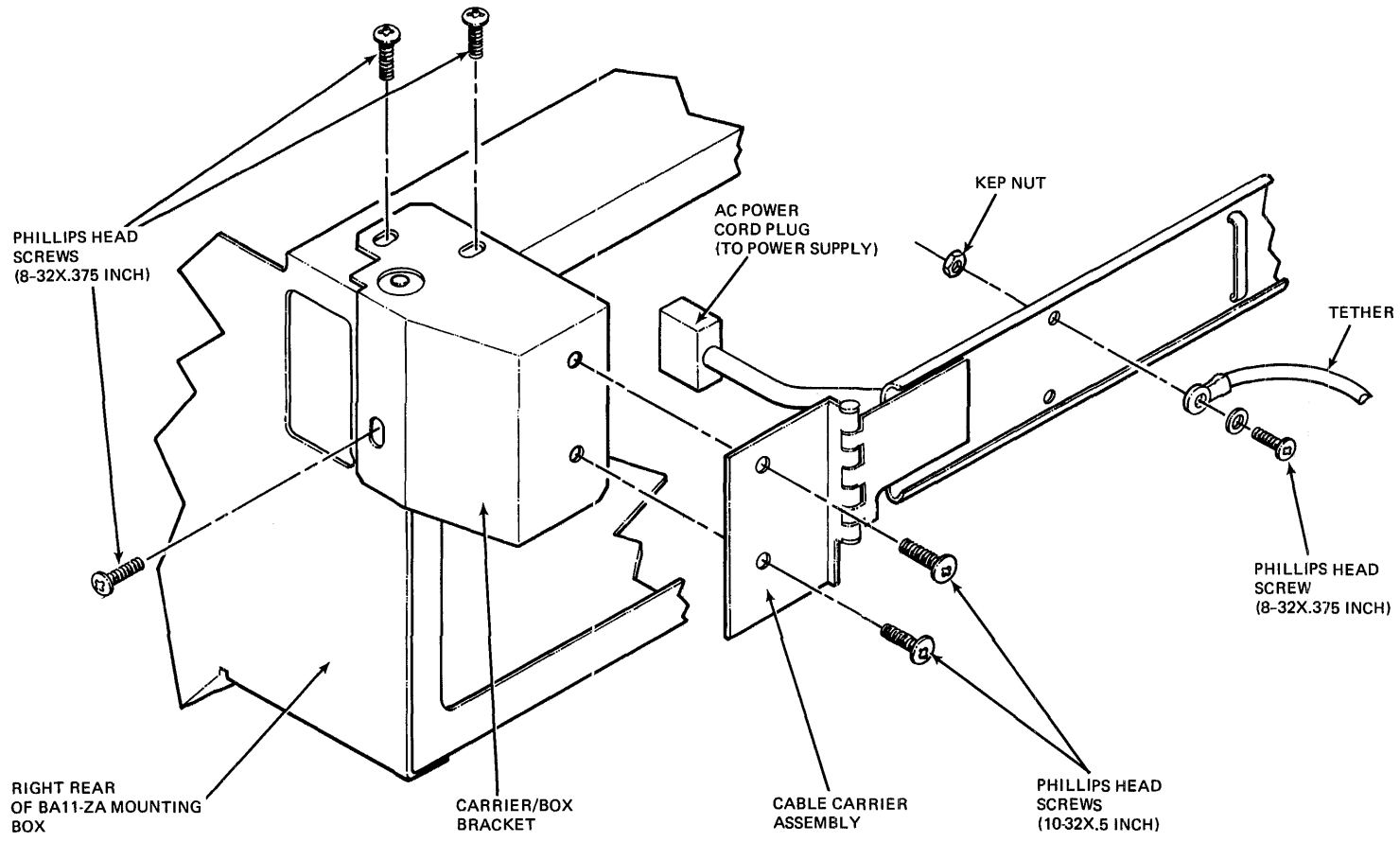

Figure 5-4 Mounting the BA11-Z Mounting Box to the Cabinet Slides



TK-8592

Figure 5-5 Mounting the Carrier/Box Bracket to the Rear of the BA11-Z Mounting Box

CHAPTER 6
VAX-11/730 SYSTEMS 1 AND 2
OPTION INSTALLATION AND CABLE ROUTING

6.1 GENERAL

This chapter contains the procedures needed to install options and to route option cabling within the CPU mounting box and system cabinet.

NOTE

When option installation and/or cable routing is performed, remove the system cabinet rear door by performing step 2 of Paragraph 3.3.2, and the CPU mounting box service interlock (tether) by performing step 2 of Paragraph 3.4.1.

CAUTION

Fully extend the stabilizer bar from the cabinet to prevent tipping of the cabinet when the CPU mounting box is extended.

6.2 MODULE INSTALLATION

Perform the following steps to install modules in the CPU mounting box:

1. Withdraw the mounting box from the cabinet and open the module access cover on the left side of the box by releasing the four Phillips head quarter-turn fasteners (Figure 3-16).
2. Disconnect and/or remove any cables which would interfere with module insertion in the slots indicated below:

Module	CPU Backplane Slot
FPA (M8389)	2
MEMORY (MS730)	6-10
TU80 CONTROLLER (M7454)	10
DMF32 (M8396)	11
UNIBUS Expansion (M9014)	12

3. Follow the module configuration rules below and insert the option module into the backplane:
 - a. Install memory modules in sequential slots (no blank slots between modules).
 - b. Install a bus grant card (G7273) in connectors C and D of slots 6-10 and 12 if modules are not installed in these slots.
 - c. Install the TU80 controller module (M7454) in slot 10, if a UNIBUS expander cabinet is not included in the system configuration (if a UNIBUS expander cabinet is included in the system configuration, the TU80 controller module is installed in slot 2 of the UNIBUS expander box).
 - d. Install the UNIBUS expansion module (M9014) into slot 12, connectors A and B.
4. Reconnect cables that were disconnected in step 2.

6.3 I/O PANEL INSTALLATION

When the UNIBUS expansion module is installed, the I/O panels for these options must be installed into the system bulkhead. Also, when the UNIBUS expansion and TU80 modules are installed, the I/O panels for these options must be installed into the system I/O panel. The following paragraphs describe the installation of these option I/O panels.

6.3.1 DMF32 I/O Panel Installation

The optional DMF32 I/O panel must be installed in the system bulkhead. Perform the following steps to install the DMF32 I/O panel:

1. Remove the eight screws holding the four blank plates to the system bulkhead (Figure 6-1).
2. Position the tab on the DMF32 I/O panel in the slot on the system bulkhead and lower the DMF32 I/O panel into place (Figure 6-2).
3. Insert and tighten the eight screws into the DMF32 I/O panel and system bulkhead (Figure 6-2).

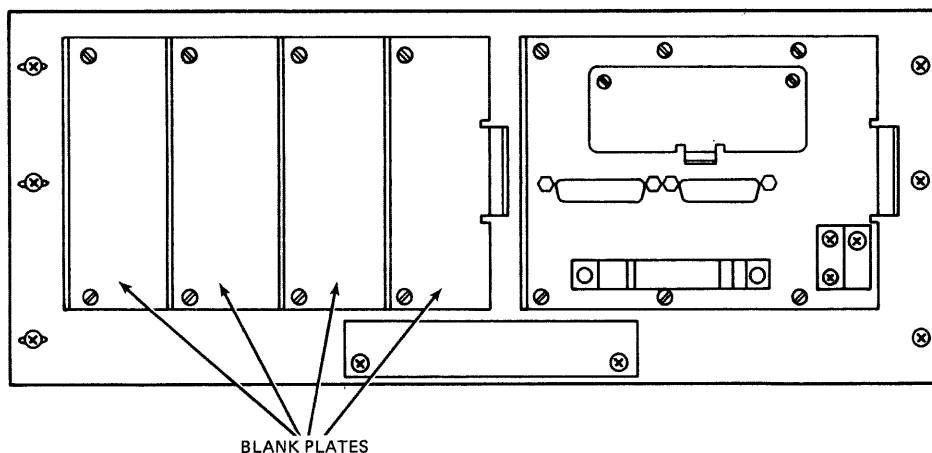

TK-11179

Figure 6-1 Removal of Blank Panels from the System Bulkhead

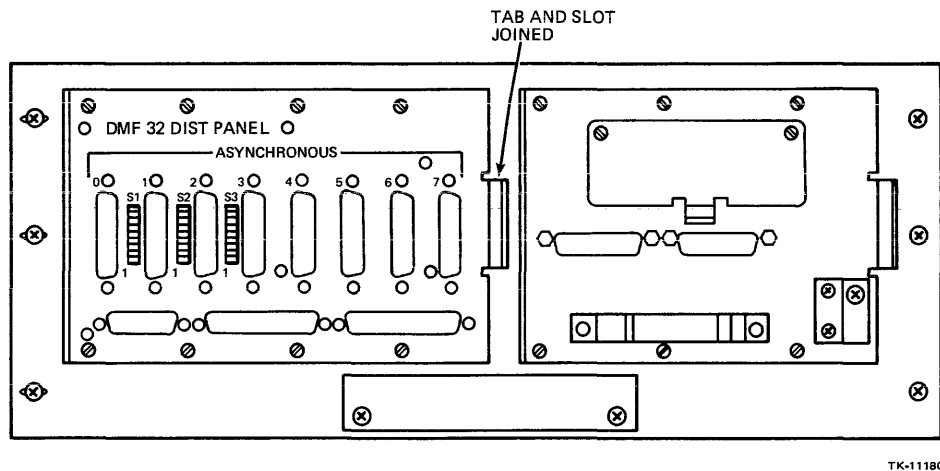

Figure 6-2 Installation of the DMF32 I/O Panel into the System Bulkhead

6.3.2 UNIBUS Expansion I/O Panel Installation

The optional UNIBUS expansion cable I/O panel must be installed in the system I/O panel. Perform the following steps to install the expansion cable I/O panel:

1. Remove the two screws holding the blank panel to the system I/O panel (Figure 6-1).
2. Assemble the UNIBUS expansion cable I/O panel as shown in the documentation shipped with the expansion cable.
3. Position the tab on the expansion cable I/O panel into the slot on the system I/O panel and position the panel onto the system I/O panel (Figure 6-3).
4. Tighten the two screws on the expansion cable I/O panel into the system I/O panel.

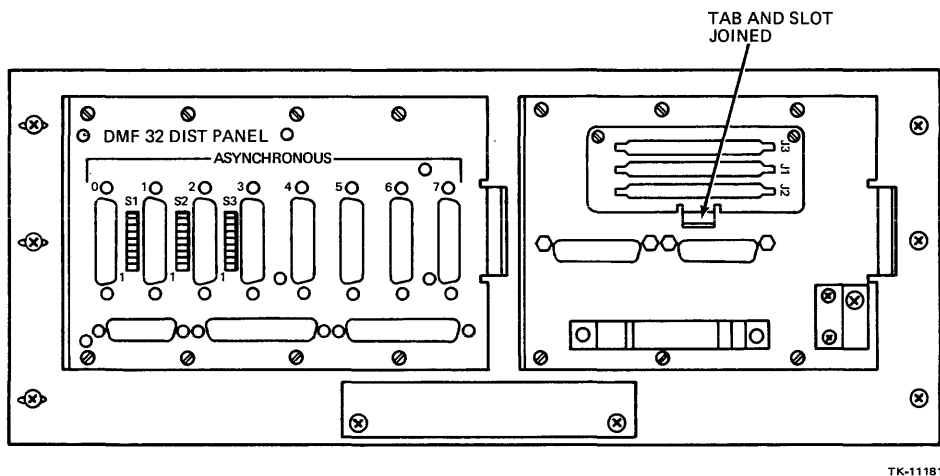

Figure 6-3 Installation of the UNIBUS Expansion Cable I/O Panel into the System I/O Panel

6.3.3 TU80 I/O Panel Installation

The optional TU80 I/O panel must be installed in the system I/O panel. Perform the following steps to install the TU80 I/O panel:

1. Remove the two screws holding the blank panel to the system I/O panel (Figure 6-1).
2. Assemble the TU80 I/O panel as shown in the documentation shipped with the TU80 magtape unit.
3. Position the tab on the TU80 I/O panel into the slot on the system I/O panel and position the panel onto the system I/O panel (Figure 6-4).
4. Tighten the two screws on the TU80 I/O panel into the system I/O panel.

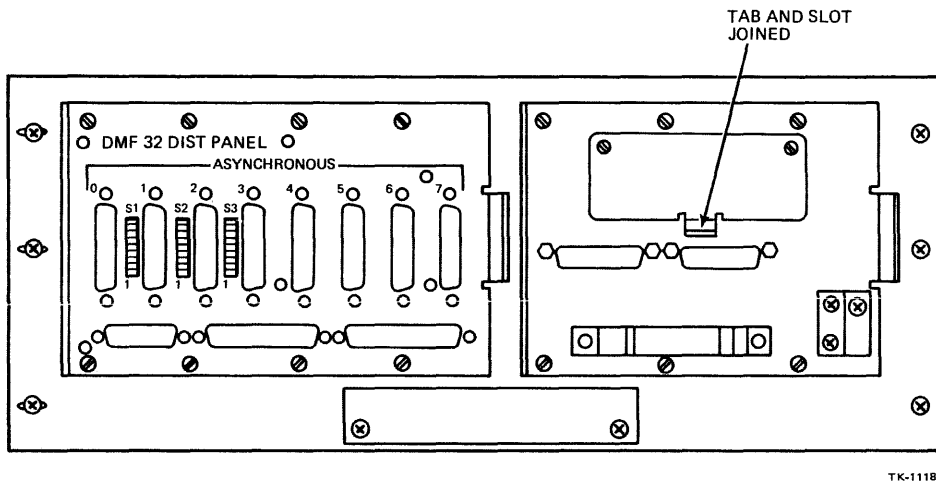

Figure 6-4 Installation of the TU80 I/O Panel into the System I/O Panel

6.4 INTERNAL CABLE ROUTING

All data cables emanating from the CPU mounting box (BA11-Z) are routed through the catch pan (Figure 6-5) and cable retractor tray (Figure 6-6) assemblies. These cables are connected to either the system I/O panel or the DMF32 I/O panel.

The following paragraphs describe the routing of all cables through these assemblies in the VAX-11/730 System 1 and 2. These paragraphs are in the order that cables should be routed (i.e., WCS first, DMF32 second, UNIBUS or TU80 third, etc.). Also, either the TU80 cables or the UNIBUS cables, not both, are routed through the catch pan and cable retractor tray assemblies.

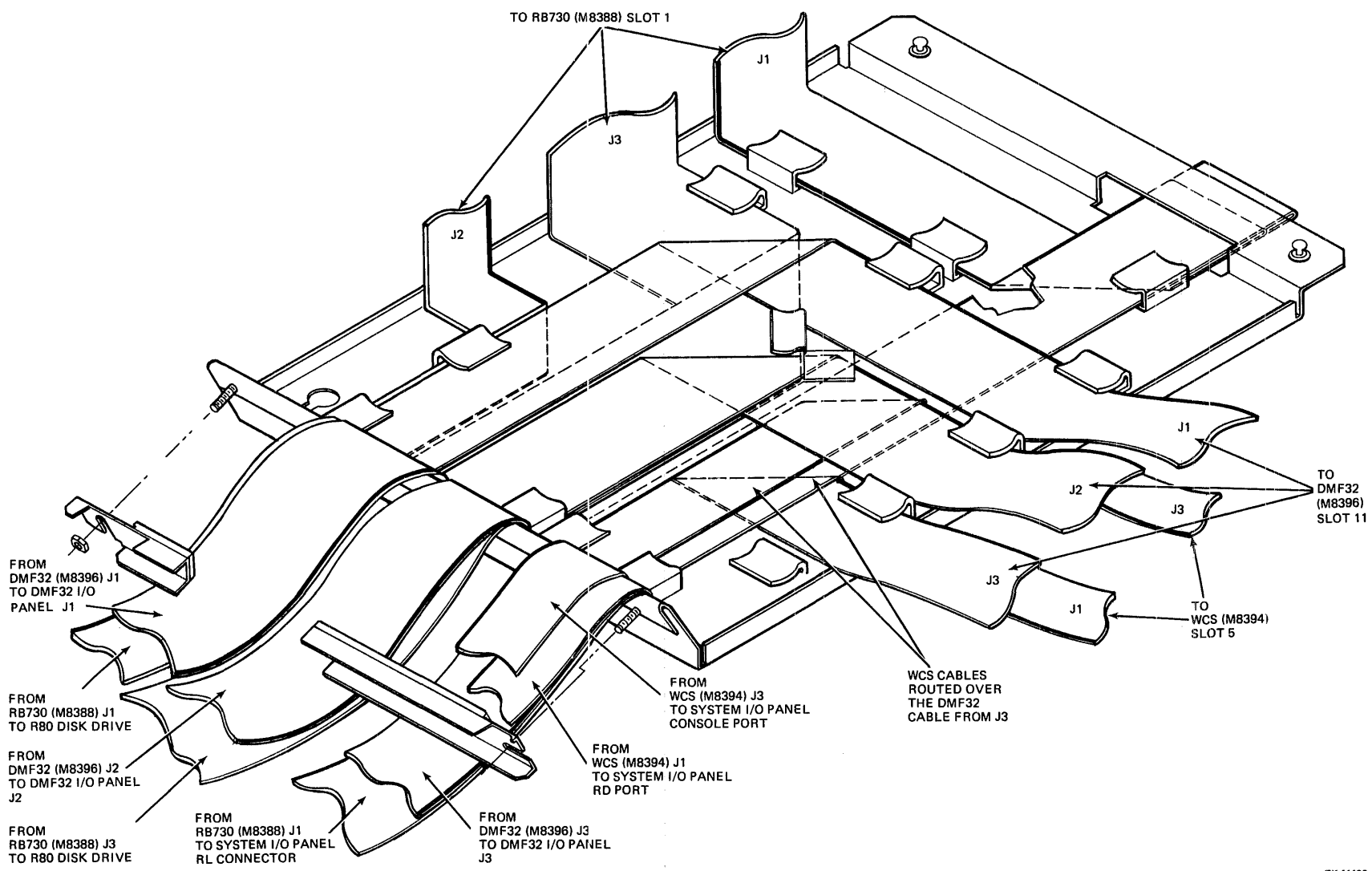

Figure 6-5 Catch Pan Assembly with Cables Routed

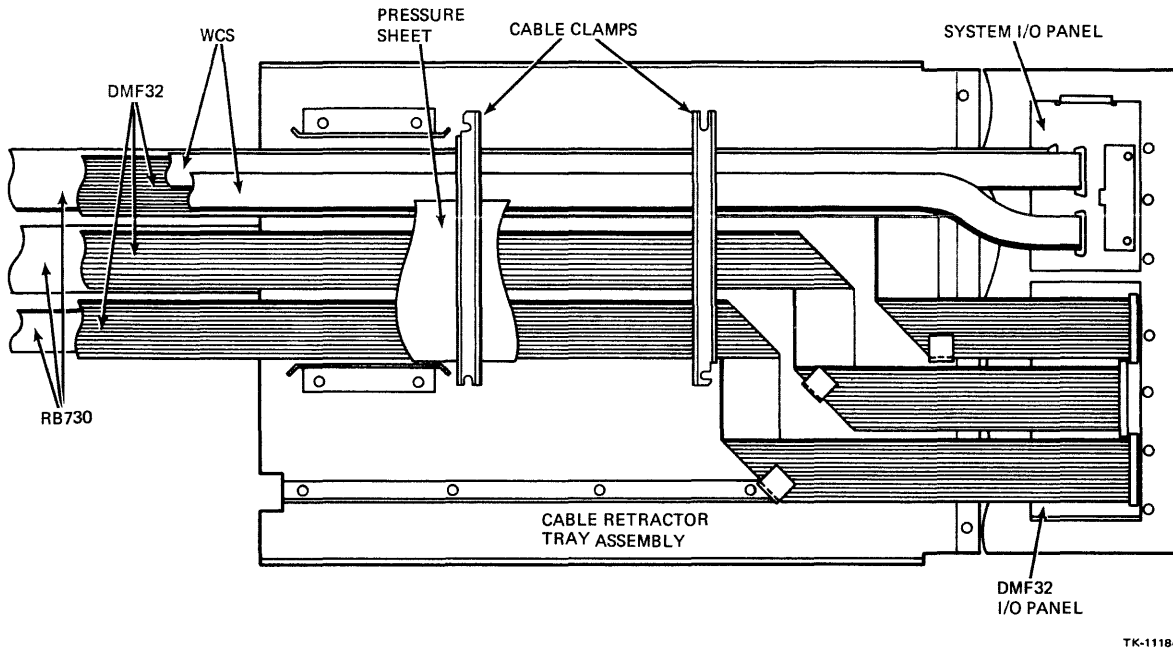
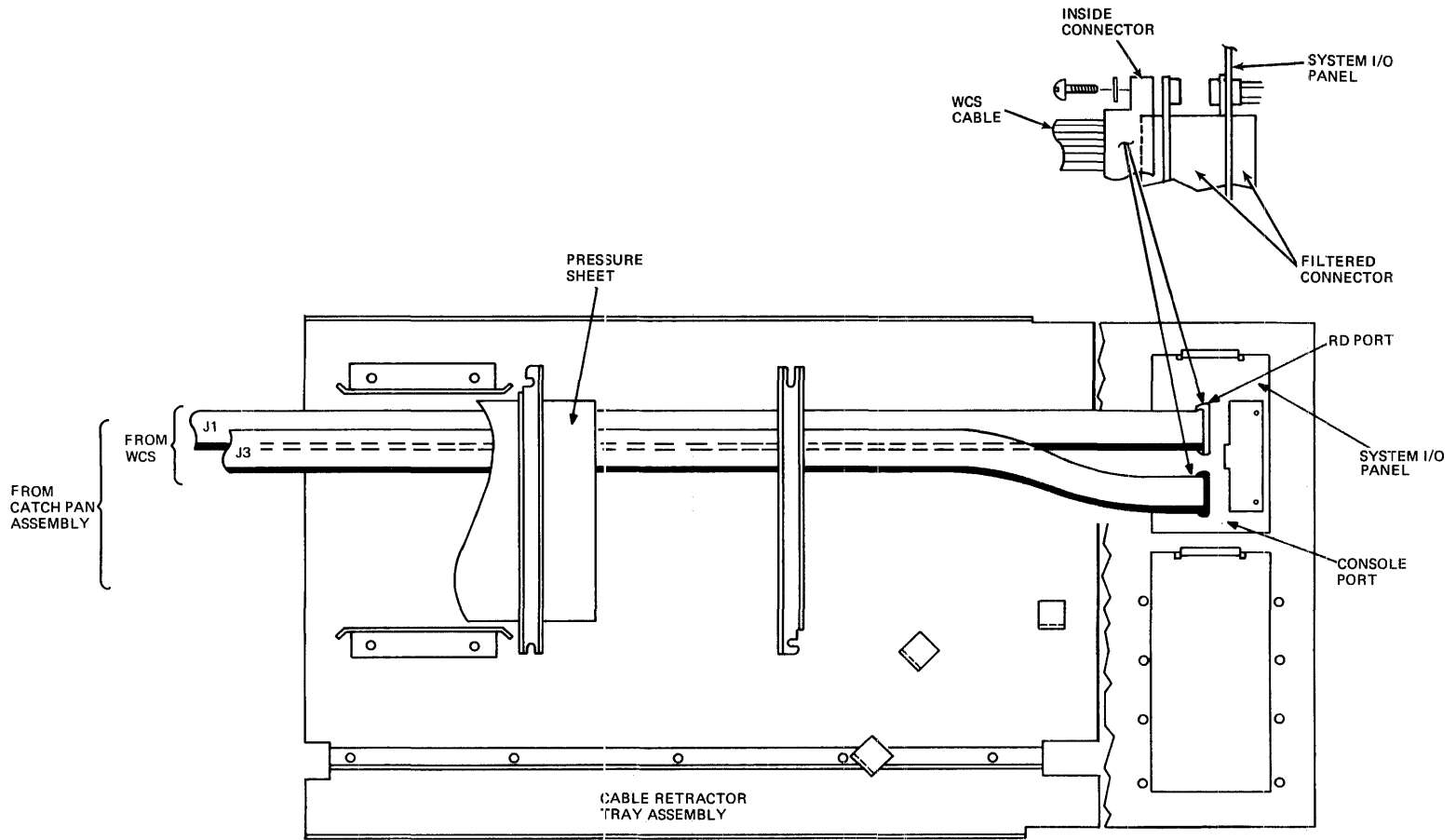

Figure 6-6 CPU Cable Retractor Tray Assembly with Cables Routed

6.4.1 WCS Cable Routing

The two WCS cables are the first set of cables to be routed through the catch pan and cable retractor tray assemblies. In the VAX-11/730 System 1 and 2, the WCS cables are already routed through the catch pan and cable retractor tray assemblies, but in the VAX-11/730-ZA (OEM box) the WCS cables are only routed through the catch pan assembly and must be routed through the cable retractor tray assembly. Perform the following steps to route the WCS cables through the cable retractor tray assembly:

1. Remove the two cable clamps on the cable retractor tray assembly, hold the pressure sheet out of the way, and route the WCS cables through the tray assembly, as shown in Figure 6-7.
2. Connect the WCS cables to the connectors on the rear of the system I/O panel as outlined below. (Refer to Figure 6-7.)
 - a. Connect the cable from J1 to the RD port connector.
 - b. Connect the cable from J3 to the CONSOLE port connector.
3. Fold any excess cable up and place it under the cable clamp closest to the I/O panel, then lay the pressure sheet on top of the cables and replace the cable clamps.
4. Tighten the cable clamps at the rear and bottom of the catch pan assembly (Figure 6-8).
5. Tighten the two cable clamps on the cable retractor tray assembly.



TK-11185

Figure 6-7 WCS Cables Routed Through the CPU Cable Retractor Tray Assembly and Connected to the System I/O Panel

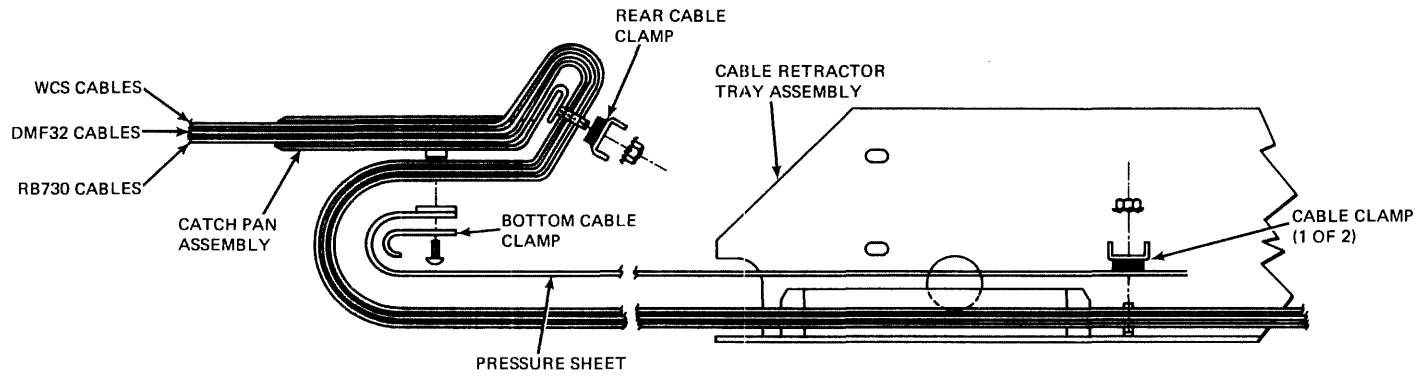

TK-11186

Figure 6-8 Side View of the CPU Cable Retractor Tray Assembly with Cables Routed

6.4.2 DMF32 Cable Routing

The DMF32 cables from the DMF32 module in slot 11 of the CPU backplane are the second set of cables to be routed through the catch pan and cable retractor tray assemblies. These cables must be routed from slot 11 in the module cage assembly through the catch pan and cable retractor assemblies and connected to the DMF32 I/O panel. The cables are connected to the DMF32 I/O panel at the rear of the system I/O panel. Perform the following steps to route and connect the DMF32 cables:

1. Disconnect any cabling in the module cage that is routed through the catch pan assembly.
2. Remove the catch pan assembly from beneath the mounting box by performing the following steps (Figure 6-9):
 - a. Release the two quarter-turn fasteners at the front of the catch pan assembly.
 - b. Slide the pan assembly back until the keyed holes in the rear of the assembly are free of the screws on the bottom of the mounting box.

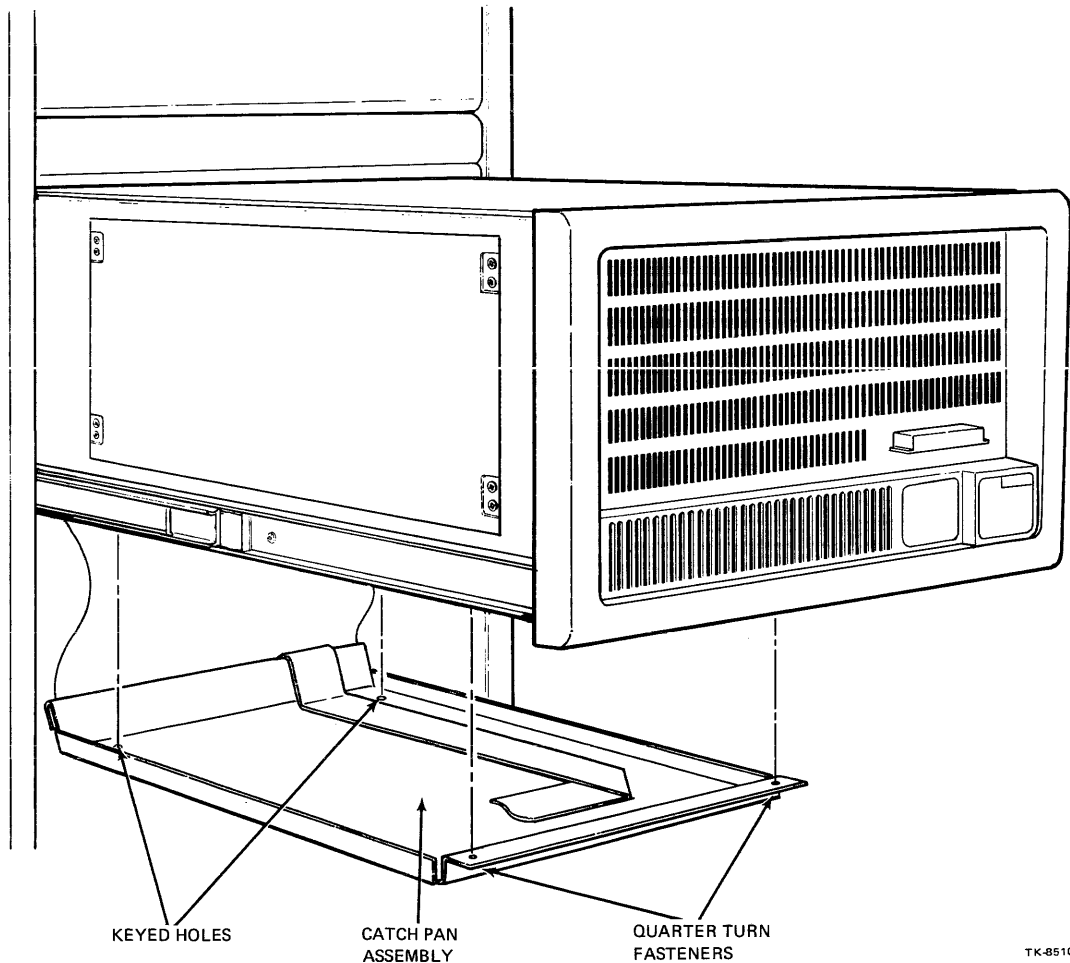
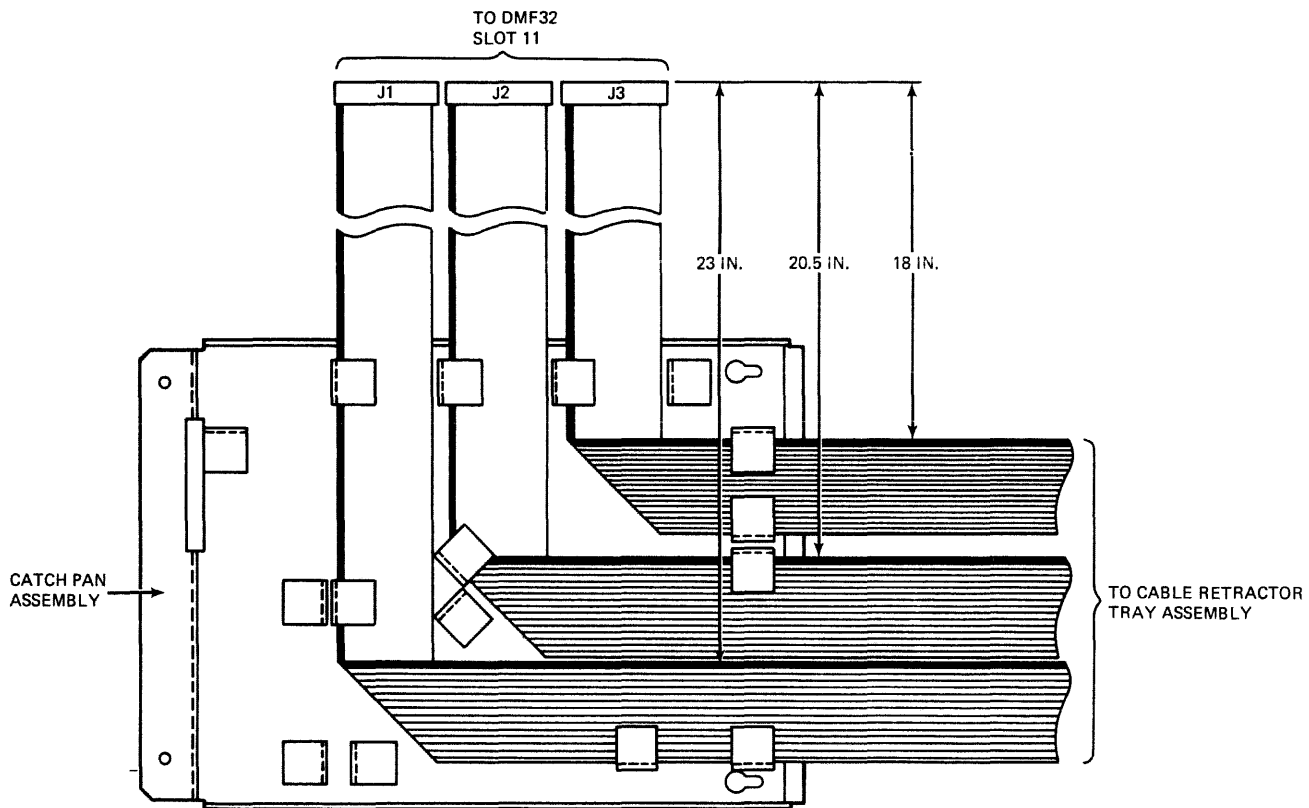

Figure 6-9 Catch Pan Assembly Removal from the CPU Mounting Box

3. Route the DMF32 cables through the two cable clamps at the rear and bottom of the catch pan assembly, as shown in Figure 6-8.
4. Route the DMF32 cables through the catch pan assembly, as shown in Figure 6-10. Ensure that the cables extend the proper length out of the side of the assembly as shown in the figure. Also, ensure that the WCS cables are routed over the DMF32 cable from J3 at the 90 degree bend. This ensures that the WCS cables exit the catch pan assembly over the DMF32 cable from J3 (Figure 6-5).
5. Remove the two cable clamps on the cable retractor tray assembly, hold the pressure sheet out of the way and route the three DMF32 cables through the ribbon cable clamps, as shown in Figure 6-11.
6. Connect the cables to the DMF32 I/O panel as outlined below (Figure 6-11):
 - a. Connect the cable from (M8396) J1 to J1 on the panel.
 - b. Connect the cable from (M8396) J2 to J2 on the panel.
 - c. Connect the cable from (M8396) J3 to J3 on the panel.
7. Fold any excess cable up and place it under the cable clamp closest to the I/O panel.



TK-11187

Figure 6-10 DMF32 Cables Routed Through the Catch Pan Assembly

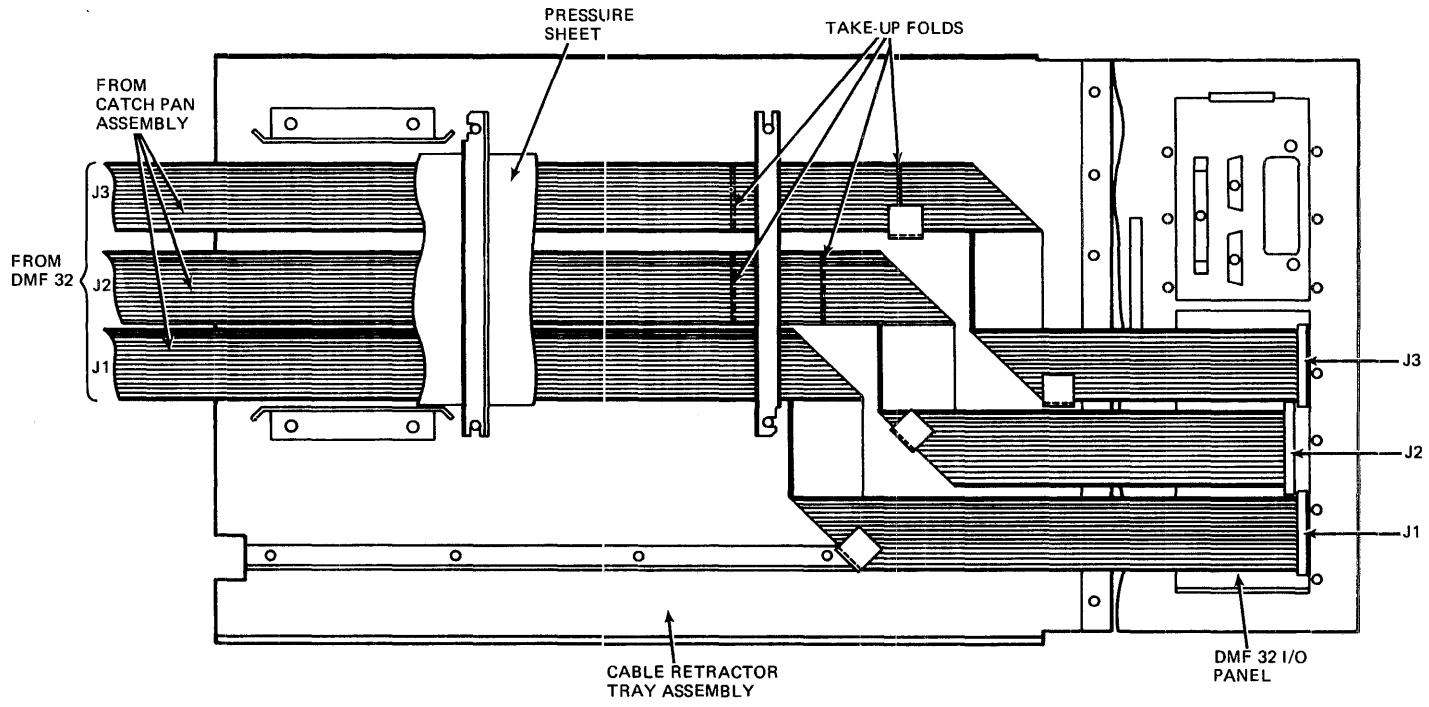

TK-11188

Figure 6-11 DMF32 Cables Routed Through the CPU Cable Retractor Tray Assembly and Connected to the DMF32 I/O Panel

8. If any other cables need to be routed do that at this time.
9. Lay the pressure sheet on top of the cables, then replace and tighten the two cable clamps.
10. Tighten the cable clamps at the rear and bottom of the catch pan assembly (Figure 6-8).
11. Route the DMF32 cables into the module cage assembly and connect them to the DMF32 module (J1, J2 and J3) in slot 11.
12. Route any cabling that was disconnected in step 1 into the module cage. Assemble and connect them to their respective modules.
13. Replace the catch pan assembly by reversing the substeps in step 2.
14. Fold service loops in all cables in the module cage (Figure 6-12) and replace the module access cover.

6.4.3 UNIBUS Cable Routing

The UNIBUS expansion cables from the UNIBUS expansion module in slot 12 are the third cable set to be routed through the catch pan and cable retractor tray assemblies. These cables must be routed from slot 12 in the module cage assembly through the catch pan and cable retractor tray assemblies to the system I/O panel. These cables are connected to the UNIBUS I/O panel at the rear of the system I/O panel. Perform the following steps to route and connect the UNIBUS cables:

1. Disconnect any cabling in the module cage that is routed through the catch pan assembly.
2. Remove the catch pan assembly as described in Paragraph 6.4.2, step 2.
3. Route the UNIBUS cables through the two cable clamps at the rear and bottom of the catch pan assembly, as shown in Figure 6-8.
4. Route the UNIBUS cable through the catch pan assembly as shown in Figure 6-13. Ensure that the cables extend the proper length out of the side of the assembly as shown in the figure.
5. Remove the two cable clamps on the cable retractor tray assembly, hold the pressure sheet out of the way and route the UNIBUS cable through the tray assembly, as shown in Figure 6-14.
6. Connect the cables to the UNIBUS I/O panel as outlined below (Figure 6-14):
 - a. Connect the cable from (M9014) J1 to J3 on the panel.
 - b. Connect the cable from (M9014) J2 to J2 on the panel.
 - c. Connect the cable from (M9014) J3 to J1 on the panel.
7. Fold up any excess cable and place it under the cable clamp closest to the I/O panel.
8. Lay the pressure sheet on top of the cables, then replace and tighten the cable clamps.
9. Tighten the cable clamps at the rear and bottom of the catch pan assembly, as shown in Figure 6-8.

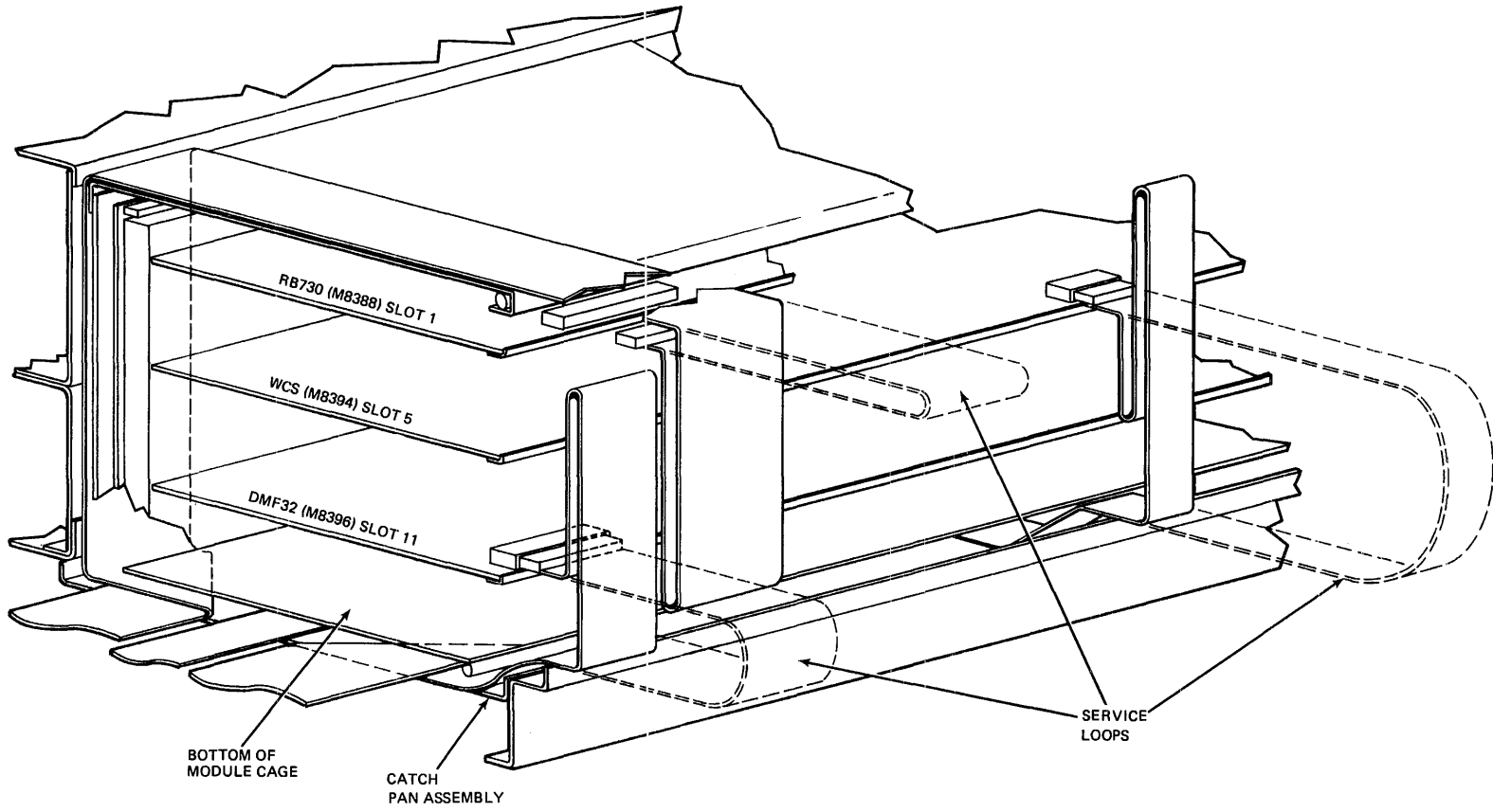
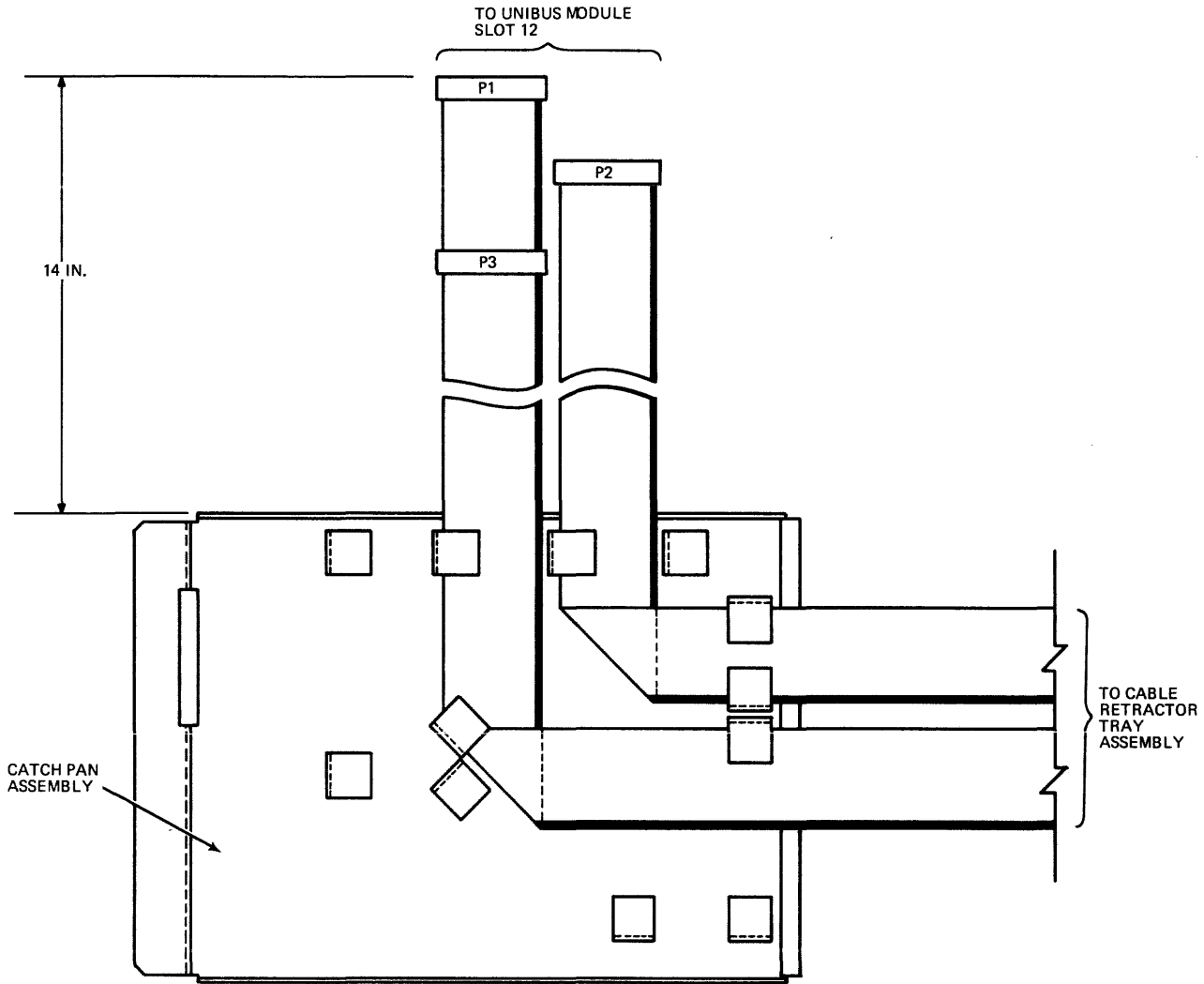

Figure 6-12 Module Cage Assembly with Cable Folding Instructions



TK-11190

Figure 6-13 UNIBUS Expansion Cables Routed Through the Catch Pan Assembly

10. Route the UNIBUS expansion cable into the module cage assembly and connect them to the UNIBUS expansion module (J1, J2 and J3) in slot 12.
11. Route any cabling that was disconnected in step 1 into the module cage. Assemble and connect them to their respective modules.
12. Replace the catch pan assembly by reversing the substeps in Paragraph 6.4.2, step 2.
13. Fold service loops in all cables in the module cage (Figure 6-12) and replace the module access cover.

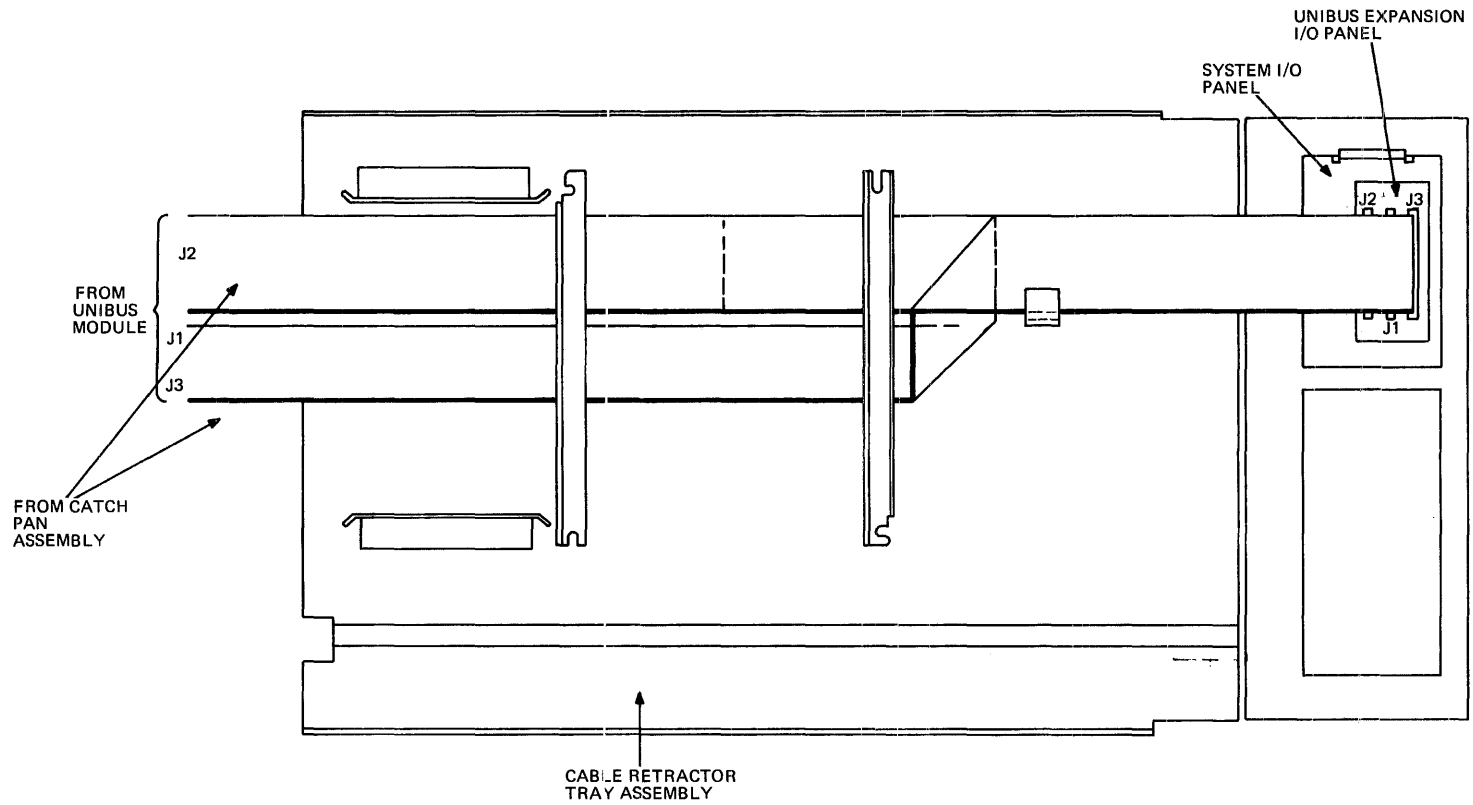

TK-11191

Figure 6-14 UNIBUS Expansion Cables Routed Through the CPU Cable Retractor Tray Assembly and Connected to the UNIBUS I/P Panel

6.4.4 TU80 Cable Routing

The TU80 controller cables are the third cable set to be routed through the catch pan and cable retractor tray assemblies. These cables must be routed from the TU80 controller (slot 12) in the module cage assembly, through the catch pan and cable retractor tray assemblies, to the system I/O panel. These cables are connected to the TU80 I/O panel at the rear of the system I/O panel. Follow the steps below to route the TU80 controller cables:

1. Disconnect any cabling in the module cage that is routed through the catch pan assembly.
2. Remove the catch pan assembly as described in Paragraph 6.4.2, step 2.
3. Route the TU80 cables through the two cable clamps at the rear and bottom of the catch pan assembly, as shown in Figure 6-7.
4. Route the TU80 cables through the catch pan assembly as shown in Figure 6-15. Ensure that the cables extend the proper length out of the side of the assembly, as shown in the figure.
5. Remove the two cable clamps on the cable retractor tray assembly, hold the pressure sheet out of the way and route the TU80 controller cables through the ribbon cable clamps, as shown in Figure 6-16.

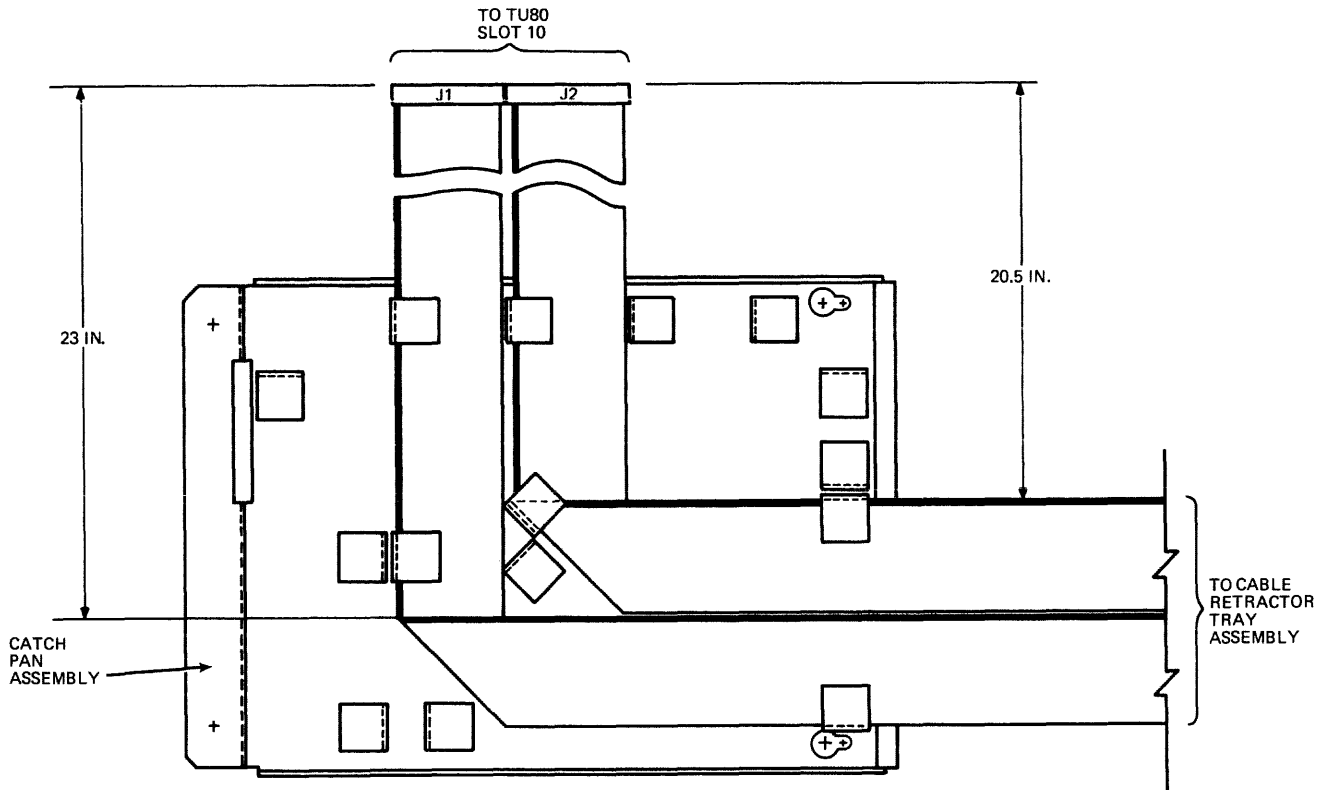

TK-11192

Figure 6-15 TU80 Cables Routed Through the Catch Pan Assembly

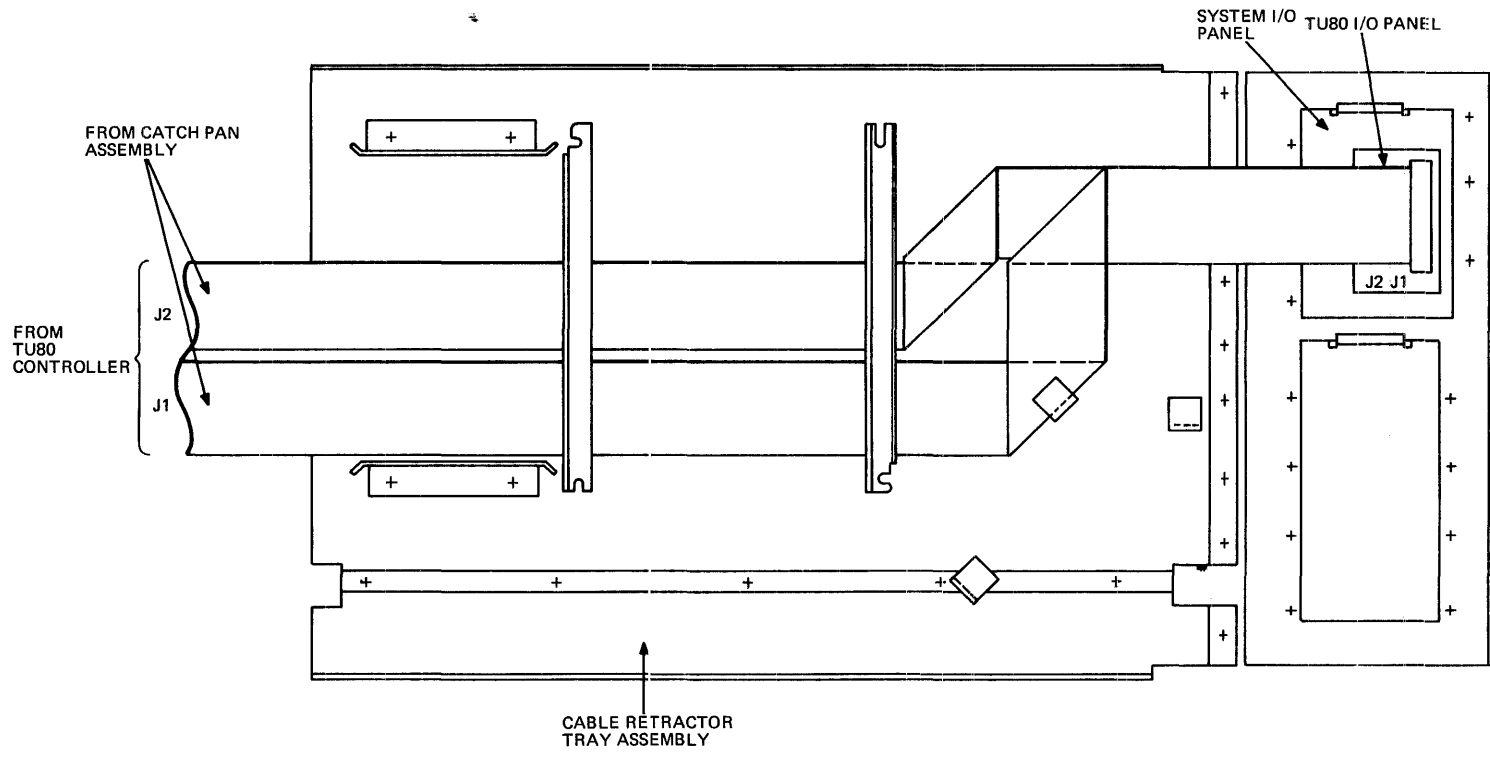

TK-11193

Figure 6-16 TU80 Cables Routed Through the CPU Cable Retractor Tray Assembly and Connected to the TU80 I/O Panel

6. Connect the cables to the TU80 I/O panel as outlined below (Figure 6-16):
 - a. Connect the cable from (M7454) J1 to J1 on the panel.
 - b. Connect the cable from (M7454) J2 to J2 on the panel.
7. Lay the pressure sheet on top of the cables, then replace and tighten the cable clamps.
8. Tighten the cable clamps at the rear and bottom of the catch pan assembly, as shown in Figure 6-8.
9. Route the TU80 cables into the module cage assembly, and connect them to the TU80 controller (J1 and J2) in slot 10.
10. Route any cabling that was disconnected in step 1 into the module cage. Assemble and connect them to their respective modules.
11. Replace the catch pan assembly by reversing the substeps in Paragraph 6.4.2, step 2.
12. Fold service loops in all cables in the module cage (Figure 6-12) and replace the module access cover.

6.5 EXTERNAL CABLE ROUTING

External cabling or cabling exiting from the system cabinet is tethered in clamps located at either the left or right bottom of the system bulkhead (Figure 6-17). These cables are routed out of the bottom of the system cabinet, between the rear door and cabinet frame.

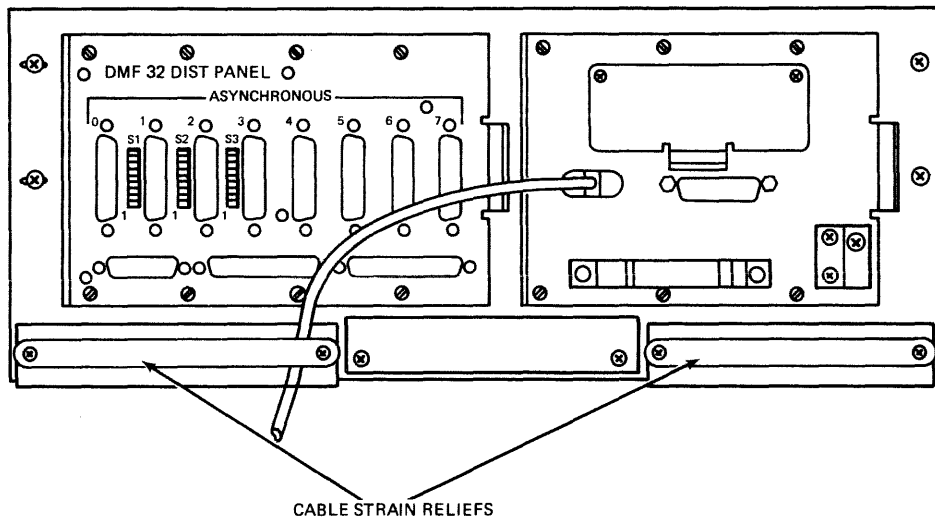

TK-11194

Figure 6-17 Cable Strain Reliefs for Exterior Cabling

CHAPTER 7

VAX-11/730 SBB OPTION INSTALLATION AND CABLE ROUTING

7.1 GENERAL

This chapter contains the procedures needed to install option modules and I/O bulkheads, and to route option cables within the VAX-11/730 SBB and system cabinet.

NOTE

Before installing option I/O bulkheads or routing option cables, remove the system cabinet front and rear doors by performing steps 2 and 3 in Paragraph 4.3.2.

After option module and option I/O bulkhead installation, and option cable routing is completed, install the system cabinet front and rear doors by performing steps 7 and 8 in Paragraph 4.7.

7.2 CONFIGURATION GUIDELINES

The following configuration guidelines must be observed when adding module options to the VAX/11-730 SBB system backplane (Figure 4-18).

The following configuration guidelines pertain to the CPU backplane:

- Slots 1, 3, 5, 11, and 12 are vacant.
- Slot 13 contains the DMF32 module.
- Rows A and B of slot 14 contains the UNIBUS jumper.
- Rows C through F of slot 14 may contain the TU80 or LP11 controller.
- Rows C and D of all unoccupied slots 10 through 14 must contain a G7273 UNIBUS grant card.

The following configuration guidelines pertain to the DD11-DK backplane:

- Rows A and B of slot 1 contain the UNIBUS jumper.
- Rows C through F of slot 1 may contain a quad height module.
- Rows A and B of slot 9 must contain either a UNIBUS terminator or UNIBUS expansion cable.
- Rows C through F of slot 9 may contain a quad height module, if slots 1 through 8 do not contain a UDA50 module.

- The optional UDA50 module must be the last module in the backplane.
- Slots 2 through 8 may contain hex height modules.
- Row D of all unoccupied slots must contain a GRANT continuity card.
- The total +5 Vdc current used by modules in the backplane must not exceed 32 A.
- The total +15 Vdc current used by modules in the backplane must not either exceed 2.4 A, if the CPU backplane contains a DMF32 module or 3.0 A, if the CPU backplane does not contain a DMF32 module.
- The total -15 Vdc current used by module in the backplane must not exceed 3.0 A.

7.3 OPTION MODULE INSTALLATION

Perform the following steps to install option modules into the CPU mounting box:

CAUTION

Before extending the CPU mounting box from the system cabinet, fully extend the stabilizer bar.

1. Slide the CPU mounting box release latch to the left and withdraw the box from the cabinet (Figure 4-16).
2. Remove the four screws that hold the top cover assembly to the mounting box, and remove the cover (Figure 4-18).
3. Select the option module slot as outlined in Paragraph 7.2 (Figure 4-18) and install the module.
4. If an I/O panel is included with the option module, install that panel into the system I/O panel as outlined in Paragraph 7.4.
5. If data cables are included with the option module, route the cables as outlined in Paragraph 7.5.
6. If I/O panels and data cables are not included with the option module, perform the following steps:
 - a. Replace the top cover and install and tighten the mounting screws.
 - b. Depress the mounting box slide locks and slide the CPU mounting box back into the cabinet (Figure 4-21).
 - c. Replace the system cabinet front and rear doors.

7.4 OPTION I/O PANEL INSTALLATION

When an option that includes an I/O panel is installed in the system, the I/O panel must be installed into the system I/O panel. Perform the following steps to install an option I/O panel into the system I/O panel:

1. Locate the installation position (Figure 7-1) and remove the Phillips head screws holding the blank plate(s) to the system I/O panel.
2. Position the option I/O panel into the system I/O panel installation position.

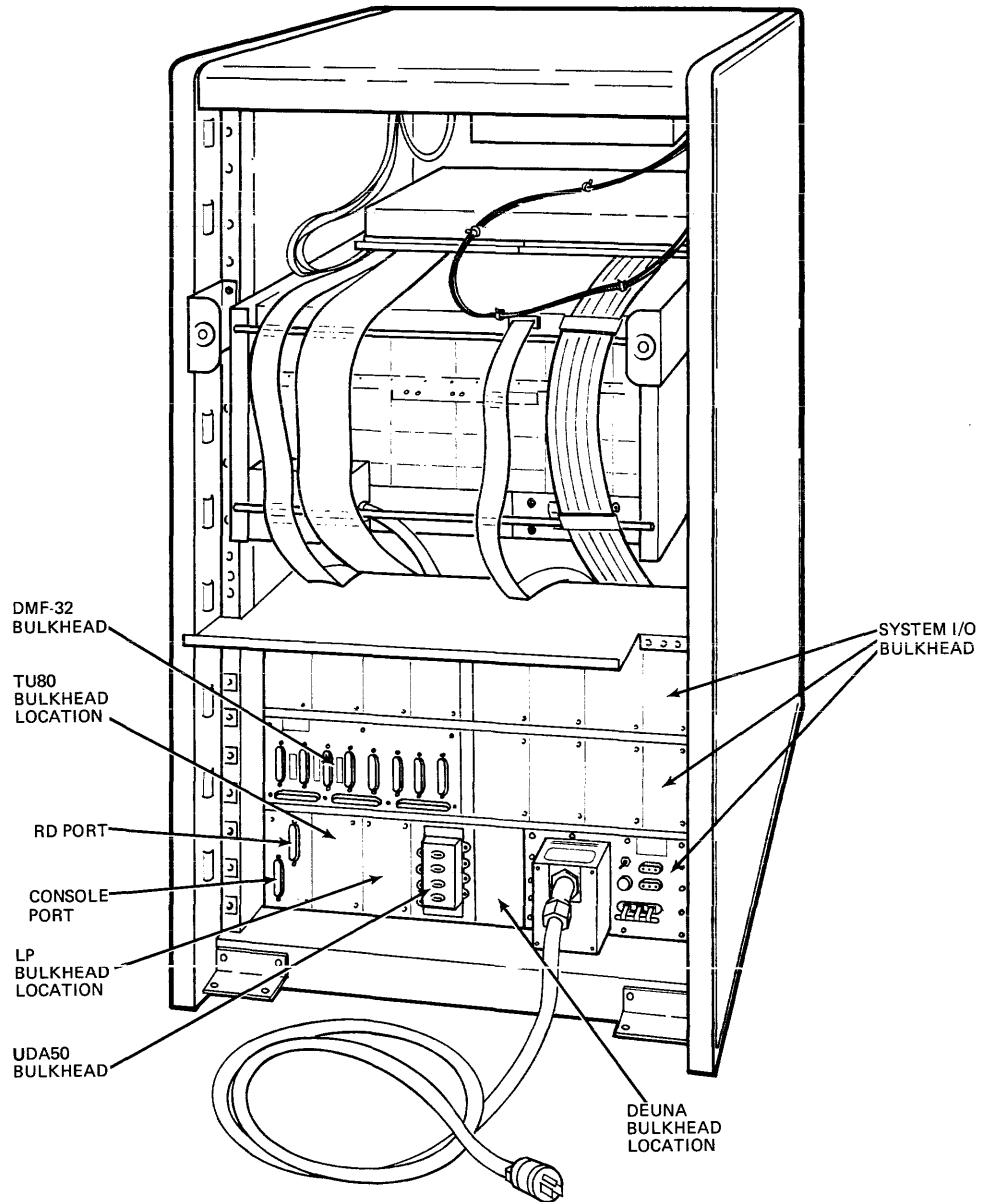

TK-11195

Figure 7-1 Device Bulkhead Location on the VAX-11/730 SBB System I/O Bulkhead

3. Insert and tighten the option I/O panel mounting screws into the system I/O panel.
4. Route data cables to the option I/O panel as outlined in Paragraph 7.5.

7.5 OPTION CABLING

All option data cabling emanating from the CPU mounting box is either routed to the system I/O bulkhead or, if the cabling is the UNIBUS expansion cable, is routed through the cable trough on the side of the system cabinet and into the expander cabinet.

1. Connect data cables to option modules as shown in the installation documentation shipped with the option.
2. For the UNIBUS expansion cable, remove the UNIBUS terminator cord from slot 9 (Rows A and B) of the DD11-DK expander backplane in the mounting box and connect the UNIBUS expansion cable to that slot.
3. Remove the cable clamps on the mounting box and system cabinet (Figures 7-2, 7-3 and 7-4).
4. Fold and route the cables from the backplane, through the mounting box cable clamp then over the rear of the mounting box, as shown in Figures 7-2 and 7-3.
5. Replace the mounting box cable clamp.
6. Replace the top cover assembly and four mounting screws.
7. Depress the CPU mounting box slide locks and slide the mounting box back into the cabinet (Figure 4-20).

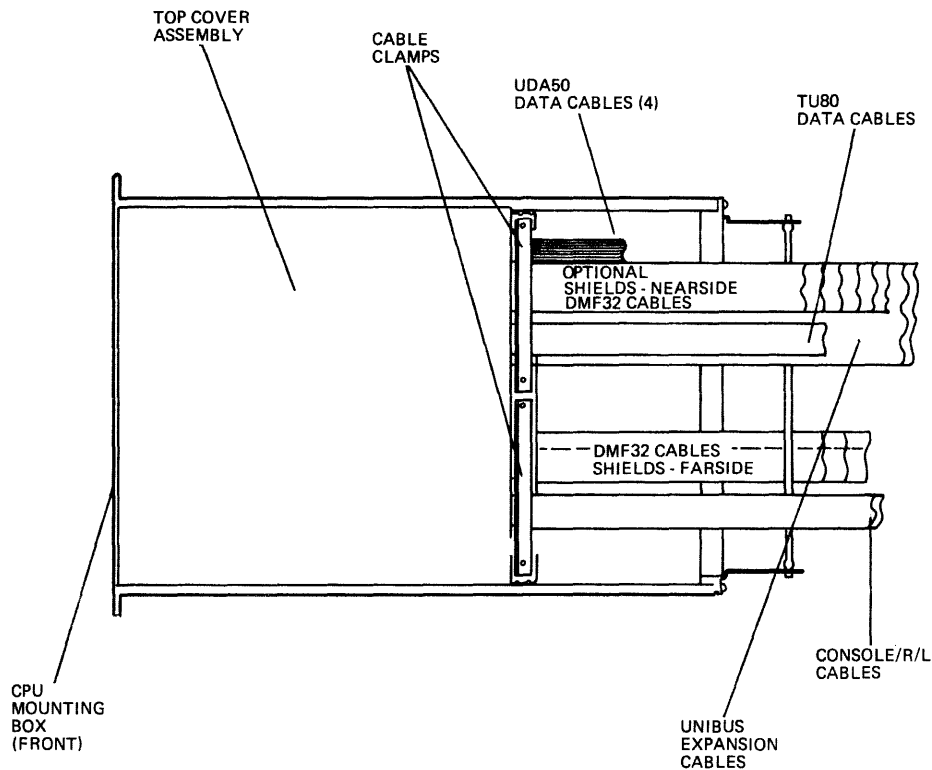

TK-11196

Figure 7-2 Cable Routing from the CPU Mounting Box

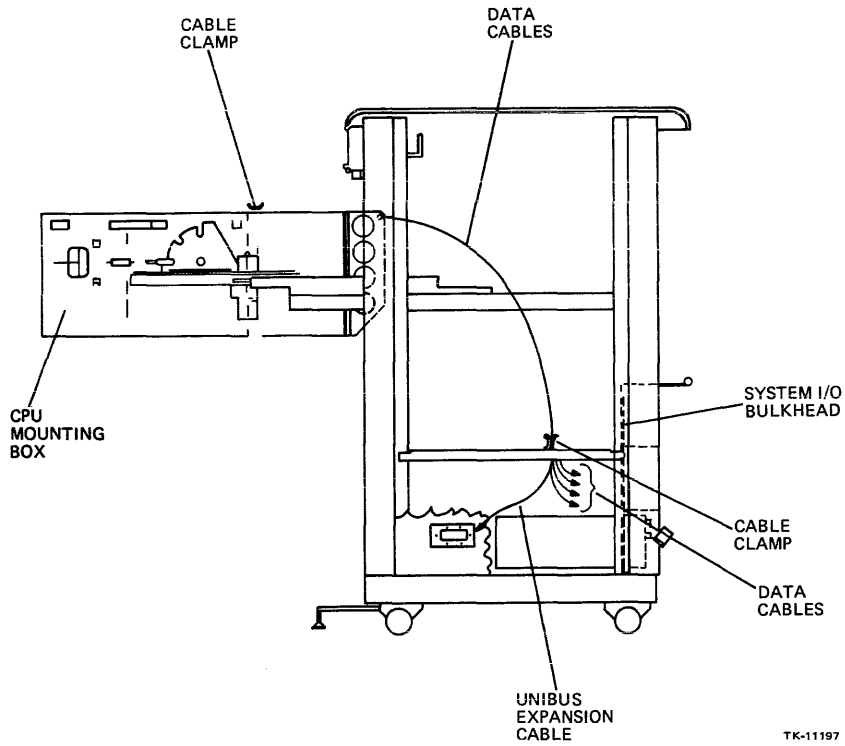

Figure 7-3 Cable Routing Through the System Cabinet with the CPU Mounting Box Extended

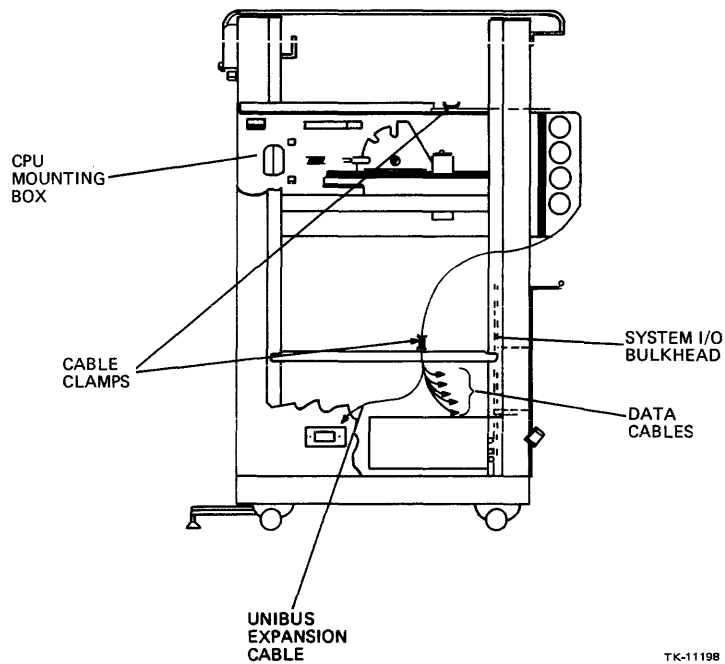

Figure 7-4 System Cabinet Cable Clamp Replacement with the CPU Mounting Box Set into the Cabinet

8. Route the cables off the rear of the mounting box through the cabinet cable clamp then to the system I/O bulkhead, as shown in Figure 7-3.
9. Route the UNIBUS expansion cable through the system cabinet shield insert knockout into the expander cable trough/shielding insert and into the expander cabinet (Figure 7-4).
10. Connect data cables to option I/O bulkheads as shown in the installation documentation shipped with the option.
11. Replace the cable clamp on the system cabinet.

7.6 CABLING FROM THE SYSTEM CABINET

All data cables exiting the system cabinet (except the UNIBUS expansion cable) are connected to an I/O panel on the system I/O panel and routed out of the cabinet, under the rear door.

CHAPTER 8 ACCEPTANCE TESTING

8.1 GENERAL

This chapter provides two methods of performing acceptance testing on the VAX-11/730 system 1 and 2, and the VAX-11/730 SBB after hardware installation is complete. The preferred method is to perform acceptance testing using the Customer Runnable Diagnostics (CRD), then the User Environment Test Package (UETP). CRD is a special program to execute micro- and macrodiagnostics in the VAX-11/730 diagnostic system with a single command and minimum participation needed from the installer. Also, during CRD only "plain English" informational messages are displayed.

NOTE

If the VAX-11/730 SBB system configuration does not include an RA60 disk drive, CRD's cannot be executed until CRD's are copied to the system disk. Since the load device for a system without an RA60 disk drive is a TU80, the VAX 725/730 CMPLT DIAG set is on a magnetic tape. CRD's do not recognize a tape drive as the load device for the diagnostics programs, so acceptance testing must be done as described in Paragraph 8.4.

The other method (which is very time-consuming) is to execute all the micro- and macrodiagnostics in the VAX-11/730 diagnostic system using the diagnostic command language. The UETP is also executed in this method.

In both methods a third diagnostic is executed when the CPU goes into the console I/O mode. This diagnostic is the self-test. When the self-test is completed satisfactorily, the word "CONVxyz" is printed.

NOTE

In the actual printing of the word "CONVxyz", the "xyz" is replaced by the version number of the console microcode.

CAUTION

Ensure that the stabilizer foot is fully extended before sliding any equipment out of the cabinet. This prevents tipping of the cabinet.

8.2 ACCEPTANCE TESTING WITH CUSTOMER RUNNABLE DIAGNOSTICS (CRD)

The procedures for CRD acceptance testing on the VAX-11/730 system 1 and 2, and the VAX-11/730 SBB are identical, but the primary load paths (RL02 or RA60) are different. The following procedure lists both devices.

Perform CRD acceptance testing on a VAX-11/730 system by performing the following steps:

1. Insert the TU58 tape cartridge #34, labeled VAX 11725/730 CONSOLE, into TU58 tape drive 1.
2. Insert the TU58 tape cartridge #36, labeled 11725/730 MICRODIAG, into TU58 tape drive 0.
3. Insert the diagnostic distribution disk cartridge (RL02 #1 or RA60 #1 labeled VAX 725/730 CMPLT DIAG) into either the RL02 (DQA1) or RA60 (DJA0 or DJA1).

NOTE

DJA1 takes precedence over DJA0.

4. Ensure disk drives 1 and 0 are READY (LOAD buttons are depressed and READY lights are on).
5. Ensure disk drives 1 and 0 are not write-protected (PROT button is not depressed and light is not on).
6. Ensure that the AUTO/RESTART switch is in the OFF position.
7. Power up the system by setting the keyswitch to the LOCAL position.

The console terminal prints: CONVxyz; certain commands executed by the console microcode and console prompt: >>>.

The >>> indicates that the microcode is loaded and the VAX-11/730 is in the console I/O monitor mode.

If the console terminal does not respond with the word CONVxyz or only partially prints it, the self-test has failed. To determine the problem, consult the *VAX-11/730 Diagnostic System Overview Manual*.

8. Type T to the console prompt (>>>) to invoke CRDs in the AUTO mode.

The CRD program executes for approximately 15 minutes, then if no errors are encountered, the console terminal produces a printout similar to the listing in either Example 8-1 or 8-2.

If the console terminal printout is different or additional messages are printed, refer to the *VAX-11/730 Diagnostic System Overview Manual* for an explanation.

After the CRDs complete the AUTO mode test, the MENU mode is entered.

9. In MENU mode, test all supported hardware that was not tested during the AUTO mode.
10. Exit MENU mode at the console prompt (>>>>).
11. Execute off-line and on-line macrodiagnostics on all devices not tested by the CRDs as outlined in Paragraph 8.3.3. Use the diagnostic help files for preparation of the devices to be tested.

**** BEGIN VAX-11/725,730 AUTO TEST ****
VERSION x.x RUN TIME APPROXIMATELY 15:00 MINUTES

CPU PART 1		TESTING STARTED - RUN TIME = 3:30 PASSED
MEMORY		TESTING STARTED - RUN TIME = 1:30 PASSED
CPU PART 2		TESTING STARTED - RUN TIME = 0:45 PASSED
FPA		TESTING STARTED - RUN TIME = 1:30
FPA NOT AVAILABLE		
PASSED		
RB730		TESTING STARTED - RUN TIME = 0:45 PASSED
RL02 PART 1	DQA1	TESTING STARTED - RUN TIME = 0:15 PASSED
CPU PART 3		TESTING STARTED - RUN TIME = 4:00 PASSED
RL02 PART 2	DQA1	TESTING STARTED - RUN TIME = 0:30 PASSED
R80	DQA0	TESTING STARTED - RUN TIME = 0:30 PASSED
DMF32S	XGA0	TESTING STARTED - RUN TIME = 1:00 PASSED
DMF32A	TSA0-TXA7	TESTING STARTED - RUN TIME = 0:30 PASSED
DMF32P	LCA0	TESTING STARTED - RUN TIME = 0:15 PASSED

AUTO TEST COMPLETE - NO ERRORS
**** END OF VAX-11/725,730 AUTO TEST ****

MENU MODE is entered at this point.

Example 8-1 Successful CRD Program Run on a Basic RL02/R80 Configured System

**** BEGIN VAX-11/725,730 AUTO TEST ****
VERSION x.x RUN TIME APPROXIMATELY 15:00 MINUTES

VER 0.0 RUN TIME = 15.00

CPU PART 1		TESTING STARTED - RUN TIME = 3:30 PASSED
MEMORY		TESTING STARTED - RUN TIME = 1:30 PASSED
CPU PART 2		TESTING STARTED - RUN TIME = 0:45 PASSED
FPA		TESTING STARTED - RUN TIME = 1:30
FPA NOT AVAILABLE		
PASSED		
CPU PART 3		TESTING STARTED - RUN TIME = 4:00 PASSED
RA60 PART 1	DJA0	TESTING STARTED - RUN TIME = 0:15 PASSED
RA80	DUA0	TESTING STARTED - RUN TIME = 0:30 PASSED
RA60 PART 2	DJA0	TESTING STARTED - RUN TIME = 1:00 PASSED
DMF32S	XGA0	TESTING STARTED - RUN TIME = 1:00 PASSED
DMF32A	TSA0-TXA7	TESTING STARTED - RUN TIME = 0:30 PASSED
DMF32P	LCA0	TESTING STARTED - RUN TIME = 0:15 PASSED

AUTO TEST COMPLETE - NO ERRORS
**** END OF VAX-11/725,730 AUTO TEST ****

MENU MODE is entered at this point.

Example 8-2 Successful CRD Program Run on a Basic RA60/RA80

12. Build and boot the operating system as described in Chapter 2 of the *VAX-11/730 Software Installation Guide*.
13. Load and execute the UETP as described in Paragraph 8.5.

8.3 ACCEPTANCE TESTING WITH THE DIAGNOSTIC SYSTEM COMMAND LANGUAGE

Acceptance testing with the diagnostic system command language is performed by executing microdiagnostics then macrodiagnostics on all devices in the VAX-11/730 system.

8.3.1 Microdiagnostics

Microdiagnostics are performed after the self-test to check the integrity of the CPU and other devices in the standalone mode. Table 8-1 lists some of the microdiagnostics available for the VAX-11/730. A more complete list of microdiagnostics can be found in the VAX Development MAINDEC Index (EVNDX). Microdiagnostics are executed under the microdiagnostic monitor (MICMON) in the standalone mode. To load and execute the microdiagnostics perform the following steps:

1. Insert the TU58 tape cartridge #36, labeled 11725/730 MICRODIAG, into TU58 tape drive 0. (Ensure that the console tape cartridge is not inserted into drive 1.)
2. Set the AUTO-RESTART/BOOT switch to the OFF position.
3. Turn the key switch from the OFF position to the LOCAL position. The console terminal produces a printout similar to Example 8-3.
4. Execute all the microdiagnostics by typing DI to the micromonitor prompt, MIC).

Example 8-4 shows a successful microdiagnostics completion. If the console printout is different, refer to the *VAX-11/730 Diagnostic System Overview Manual* for interpretation of the results.

The microdiagnostic monitor (ENKAA) is used to load, control, and monitor the microdiagnostic tests (ENKBA through ENKBG and ENKCA through ENKCG). All of the microdiagnostics are located on a single tape cartridge.

Table 8-1 Microdiagnostics Available for the VAX-11/730

Section	Microdiagnostic
ENKAA	Micro Monitor (MICMON)
ENKBA	8085-Based Tests Part 1
ENKBB	8085-Based Tests Part 2
ENKBC	8085-Based Tests Part 3
ENKBD	8085-Based Tests Part 4
ENKBE	8085-Based Tests Part 5
ENKBF	WCS March Test
ENKBG	USART Modem Loopback Test
ENKCA	CPU Micro Part 1
ENKCB	CPU Micro Part 2
ENKCC	MCT Micro
ENKCD	CPU Micro Part 3
ENKCE	FPA Micro
ENKCF	IDC Micro
ENKCG	IDC CRD Micro

```

CONVxyz                !Successful self-test.
?27                    READ ERROR DD1
?40                    FILE NOT FOUND DD0:CONSOL.EXE

CONTINUING

?27                    READ ERROR DD1:

CONTINUING

?27 READ ERROR        DD1:

CONTINUING

VER XX.YY MMM,YY

MIC>

```

Example 8-3 Console Printout of Microdiagnostics Loading

```

MIC> DI <CR>

ENKBA-V00.03
HIGHEST WCS ADDRESS AVAILABLE:  43FF

ENKBB-V00.04

ENKBC-V00.03

ENKBD-V00.02

ENKBE-V00.03
HIGHEST WCS ADDRESS AVAILABLE:  43FF

ENKCA-V00.03

ENKCB-V00.04

ENKCC-V00.05
MEMORY SIZE IN 256K BLOCKS (IN HEXC =04
SINGLE BIT ERRORS DETECTED ON 256 KB BLOCK 00 = 000000  ARRAY
01
SINGLE BIT ERRORS DETECTED ON 256 KB BLOCK 01 = 000000  ARRAY
01
SINGLE BIT ERRORS DETECTED ON 256 KB BLOCK 02 = 000000  ARRAY
01
SINGLE BIT ERRORS DETECTED ON 256 KB BLOCK 03 = 000000  ARRAY
01
UBE NOT PRESENT

ENKCD-V00.04

ENKCE-V00.04
FPA NOT PRESENT

ENKCF-V00.00
IDC PRESENT
R80 PRESENT DRIVE 00
EOP 0001
MIC>

```

Example 8-4 Successful Loading and Completion of the Microdiagnostics on a Basic R80/RL02 Configured System

8.3.2 Loading the Console Microcode

Before any further diagnostic can be performed, the console microcode must be loaded. Perform the following steps to load the microcode:

1. Insert the TU58 tape cartridge #34, labeled VAX11725-730 CONSOLE, into TU58 tape drive 1.
2. Set the AUTO-RESTART/BOOT switch to the OFF position.
3. Turn the keyswitch from the OFF position to the LOCAL position, or if the console is in the MICMON mode (MIC) displayed on console terminal), just type RETURN.

The console terminal prints: CONVxyz. Certain commands executed by the console microcode and the console prompt >>>).

8.3.3 Macrodiagnostics

The macrodiagnostic tests are broken into five levels: 4, 3, 2R, 2 and 1. Table 8-2 lists some of the macrodiagnostics available to the VAX-11/730 basic system.

For a more complete updated list of available macrodiagnostics, consult the VAX Development MAINDEC Index (EVNDX).

Table 8-2 Macrodiagnostics Available for the VAX-11/730

Section	Level	Macrodiagnostic
EVKAA	4	Hardcore Instruction Set
EVKAB	3	Cluster-Basic Instruction Execution
EVKAC	3	Cluster-Floating-Point
EVKAD	3	Cluster-Compatibility Mode
EVKAE	3	Cluster-Privileged Architecture
ENKAX	3	11/730 Specific Cluster Exerciser
EVDLB	3	Combo-Synchronous Lines
EVDLC	3	Combo-Asynchronous Lines
EVDLD	3	Combo-Line Printer/Parallel Interface
EVRLA	3	UDA50 Disk Subsystem
EVRLB	3	UDA50 Disk Formatter
ENRKA	3	Disk-Functional
EVMBD	3	TU80 Functional Diagram Part 1
EVMBE	3	TU80 Functional Diagram Part 2
EVRGA	2	R80 Disk Formatter
EVAAB	2R	Line Printer
EVTAA	2R	Terminal Diagnostic
EVTBA	2R	Terminal Exerciser

Perform acceptance testing on all devices using the macrodiagnostics outlined in the following steps, using the *VAX-11/730 Diagnostic Overview Manual*:

1. Load and execute the level 4 diagnostics in the standalone mode.
2. Load and execute the diagnostic supervisor in the standalone mode.
3. Load and execute the level 3 diagnostics with the diagnostic supervisor in the standalone mode.
4. Load and execute the level 2 diagnostics with the diagnostic supervisor in the standalone mode.
5. Build and boot the operating system, as described in Chapter 2 of the *VAX-11/730 Software Installation Guide*.
6. Load and execute the diagnostic supervisor in the on-line mode.
7. Load and execute the level 2 diagnostics with the diagnostic supervisor in the on-line mode.
8. Load and execute the level 2R diagnostics with the diagnostic supervisor in the on-line mode.
9. Load and execute the level 1 diagnostics (UETP), as described in Paragraph 8.5.

8.4 ACCEPTANCE TESTING THE VAX-11/730 SBB SYSTEM WITHOUT AN RA60 DISK DRIVE

Customer Runnable Diagnostics cannot be executed on a VAX-11/730 SBB system without an RA60 disk drive, since that type of system has a TU80 tape drive for the user device and the CRDs cannot be executed from that device. It is suggested that acceptance testing on this type of system should be performed with the following procedure (within time constraints):

1. Execute microdiagnostics from the TU58 tape cartridge #36, labeled 11725/730 MICRODIAG, as outlined in Paragraph 8.3.1.
2. Execute the Hardcore Instruction Set (EVKAA) from the TU58 tape cartridge #7, labeled VAX 11 HARDCORE INSTR, as outlined in Chapter 6 of the *VAX-11/730 Diagnostic System User's Guide*.
3. Load and execute the diagnostic supervisor (ENSAA) from the TU58 tape cartridge #35, labeled 11725/730 DIAG SUPER, as outlined in Chapter 5 of the *VAX-11/730 Diagnostic System User's Guide*.

4. At the diagnostic supervisor prompt (DS)), type the following commands to attach the TU80, UDA50 and disk drive to the CPU and select them for testing:

```
DS> ATTACH KA730 HUB KA0 YES 03FF 1 2048 NO NO
DS> ATTACH DW730 HUB DW0
DS> ATTACH UDA50 DW0 DUA 772150 154 5 0
```

either

```
DS> ATTACH RA80 DUA DUA0
```

(for the RA80/TU80 system)

or

```
DS> ATTACH RA81 DUA DUA0
```

(for the RA81/TU80 system)

then

```
DS> ATTACH TU80 DW0 MSA0 772520 244 5
DS> SELECT DUA0,MSA0
```

5. Type the diagnostic supervisor commands to set the load path from the TU80.

```
DS> SET LOAD MSA0:[SYSMAINT]
```

6. Type the following commands to list the help on the UDA50 diagnostics and perform the preparation listed:

```
DS> HELP EVRLA
DS> HELP EVRLB
```

If the commands do not execute, then there is a fault in the TU80. Perform the following substeps to isolate the fault. If the commands do execute, skip the following substeps:

- a. Unload the diagnostic tape.
- b. Type the following command to set the diagnostic supervisor load path to the TU58 drive 0:

```
DS> SET LOAD CSA0
```
- c. Insert the TU58 tape cartridge #52, labeled VAX TU80 DIAGNOSTICS, in TU58 drive 0.
- d. Type the following commands to list the help on the TU80 diagnostics and perform the preparation listed:

```
DS> HELP EVMBD
DS> HELP EVMDE
```

- e. After the TU80 diagnostic preparation is performed, execute the diagnostics with the RUN command.
- f. When the fault is found and repaired, load the distribution tape and type the following command:

```
DS> SET LOAD MSA0:[SYSMAINT]
```

7. After UDA50 diagnostic preparation is performed, execute the diagnostic to check its load path with the RUN command:

```
DS> RUN EVRLA
```

8. If the diagnostic completes without error perform the next step. If the diagnostic encounters an error repair the fault and set at step 1 of this section perform all of the steps again.
9. Exit the diagnostic supervisor with the EXIT command, then build and boot the operating system as described in Chapter 2 of the *VAX-11/730 Software Installation Guide*.
10. Obtain the DCL prompt \$. Then, allocate and mount the diagnostic distribution tape with the following command:

```
$ ALLOCATE MSA0:
$ MOUNT MSA0: CRDPACK
```

11. Copy all diagnostics from the distribution tape to the diagnostic area on the system disk with the following commands:

```
$ SET DEFAULT DUA0:[SYS0.SYSMAINT]
$ COPY MSA0:*. * []
$ COPY/CONTIG DIAGBOOT.EXE *.*;0
$ PURGE DIAGBOOT.EXE
```

12. Deallocate and dismount the TU80:

```
$ DISMOUNT MSA0:
$ DEALLOCATE MSA0:
```

13. Gracefully shutdown the system with the following command and perform the operations questioned from the operating system to obtain the console prompt ())))):

```
$ @SYS$SYSTEM:SHUTDOWN
```

14. Insert the TU58 tape cartridge #36, labeled 11725/730 MICRODIAG, into TU58 drive 0.

15. Execute the CRDs in MENU mode with the following command:

```
>>> T/C
```

16. In MENU mode issue the commands to test supported devices that were not tested in this procedure.

17. After testing completed exit the CRDs to the console prompt ())))); then load and execute the diagnostic supervisor as performed in step 3 of this procedure.

18. Perform steps 3 through 9 of Paragraph 8.3.3 on all devices not tested in the previous steps of this procedure (Paragraph 8.4).
19. Load and execute UETP as described in the *VAX/VMS UETP User's Guide*.

8.5 EXECUTING THE USER ENVIROMENTAL TEST PACKAGE (UETP)

The UETP is executed as a final acceptance test to determine if the installed VAX-11/730 hardware and software components are in working order. Execute UETP on the VAX-11/730 as described in the *VAX/VMS UETP User's Guide*. Execute UETP on the dual RL02 configuration (VAX-11/730 system 2) as described in the same document after executing the tailoring utility.

When executing the UETP, a scratch disk pack is used to check the integration of the system hardware and software. In the dual RL02 configuration, the library disk pack must be removed and the scratch disk pack mounted. This library disk pack contains files used by the UETP. The tailoring utility accesses these files prior to executing the UETP. Execute the tailoring utility and access files on the library disk by performing the following steps:

1. Boot the operating systems and log in under the system manager account.

The console terminal responds with the DCL prompt \$.

2. Issue the following commands to execute the authorize utility:

```
$ SET DEFAULT SYSSYSTEM <CR>
$ RUN AUTHORIZE <CR>
```

The console terminal responds with the authorize utility prompt: UAF).

3. Modify the files on the library disk by typing the following:

```
UAF> MODIFY SYSTEST/DEVICE=LIBSSYSROOT <CR>
UAF> EXIT <CR>
```

4. Invoke the tailoring utility and mount the library disk with the following command:

```
$ @SYSSUPDATE:VMSTAILOR MOUNT/WRITE DQA1: <CR>
```

5. Write the following commands at the tailor prompt:

```
Tailor> COPY /FILE DIFF
Tailor> COPY /FILE PIP
Tailor> COPY /FILE SEARCH
Tailor> COPY /FILE SORT32
Tailor> COPY /FILE [SYSLIB]CONVSHR
Tailor> COPY /FILE [SYSLIB]FDLSHR
Tailor> COPY /FILE [SYSHLP]HELPLIB.HLB
Tailor> EXIT
```

6. Refer to the *VAX/VMS UETP User's Guide* for completion of the UETP.

Your comments and suggestions will help us in our continuous effort to improve the quality and usefulness of our publications.

What is your general reaction to this manual? In your judgment is it complete, accurate, well organized, well written, etc? Is it easy to use? _____

What features are most useful? _____

What faults or errors have you found in the manual? _____

Does this manual satisfy the need you think it was intended to satisfy? _____

Does it satisfy *your* needs? _____ Why? _____

Please send me the current copy of the *Documentation Products Directory*, which contains information on the remainder of DIGITAL's technical documentation.

Name _____ Street _____
Title _____ City _____
Company _____ State/Country _____
Department _____ Zip _____

Additional copies of this document are available from:

Digital Equipment Corporation
Accessories and Supplies Group
P.O. Box CS2008
Nashua, New Hampshire 03061

Attention: Documentation Products
Telephone: 1-800-258-1710

Order No. **EK-S1730-IN-003** _____

ZKO

Fold Here-----

Do Not Tear - Fold Here and Staple-----

digital™



**No Postage
Necessary
if Mailed in the
United States**

BUSINESS REPLY MAIL

FIRST CLASS PERMIT NO. 33 MAYNARD, MA.

POSTAGE WILL BE PAID BY ADDRESSEE

**Digital Equipment Corporation
Educational Services Development and Publishing
129 Parker Street, PK3-1/T12
Maynard, MA 01754**

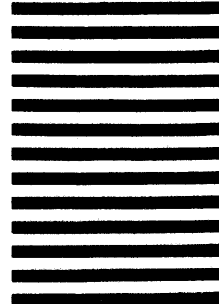

Digital Equipment Corporation • Bedford, MA 01730