

CENTRONICS

CENTRONICS

CENTRONICS

MODEL 351

**Operator, Installation &
Programming Instructions**

37403511-9B20

REV B2

APRIL 1984

CENTRONICS

CENTRONICS

CENTRONICS

CENTRONICS

**THE INFORMATION CONTAINED HEREIN IS
PROPRIETARY AND IS NOT TO BE RELEASED
OR REPRODUCED WITHOUT WRITTEN PER-
MISSION OF CENTRONICS data computer corp.**

**SERVICE INFORMATION FOR YOUR
PRINTER MAY BE OBTAINED BY CALLING
THE NUMBERS LISTED ON THE LAST PAGE
OF THIS MANUAL.
ASK FOR FIELD ENGINEERING.**

CENTRONICS®

Centronics Data Computer Corp.

1 Wall Street

Hudson, New Hampshire 03051

Tel. (603) 883-0111

An affiliate of Control Data Corporation

© Copyright 1984 Centronics Data Computer Corp.
All rights reserved
Patents pending in U.S.A. and other countries
Printed in U.S.A.

Specifications subject to change without notice

9/84 Rev. H

MODEL 351

Operator, Installation & Programming Instructions

37403511-9B20

REV B2

APRIL 1984

USERS MANUAL

WARNING

This equipment generates and uses radio frequency energy and if not installed and used properly, that is, in strict accordance with the manufacturer's instructions, may cause interference to radio and television reception. It has been type tested and found to comply with the limits for a Class B computing device in accordance with the specifications in Subpart J of Part 15 of FCC rules, which are designed to provide reasonable protection against such interference in a residential installation. However, there is no guarantee that interference will not occur in a particular installation. If this equipment does cause interference to radio or television reception, which can be determined by turning the equipment off and on, the user is encouraged to try to correct the interference by one or more of the following measures:

- reorient the receiving antenna
- relocate the computer with respect to the receiver
- move the computer away from the receiver
- plug the computer into a different outlet so that computer and receiver are on different branch circuits.

If necessary, the user should consult the dealer or an experienced radio/television technician for additional suggestions. The user may find the following booklet prepared by the Federal Communications Commission helpful: "How to Identify and Resolve Radio-TV Interference Problems." This booklet is available from the U.S. Government Printing Office, Washington, D.C. 20402, Stock No. 004-000-00345-4.

JANUARY 1, 1981

APPROVED, CLASS B

REVISION HISTORY

Publication Number—37403511-9B20

The revision history page provides a record of each revision made to the manual. The page reflects the revision sequence starting from the Preliminary release of the manual to the Production release of the manual. Preliminary manuals are revised using a number sequence, 1, 2, 3, etc., while Production release manuals are revised using a letter sequence, A, B, C, etc. The history page also provides a brief description of each manual revision. In between manual updates, Publication Change Pages (PCPs) are generated and shipped with each manual. These PCPs are incorporated into the manual of the next revision update and should be retained as a record of the change.

REVISION	DESCRIPTION
1 (April 1982)	Preliminary release of manual.
A (May 1982)	Production release of manual.
B (April 1983)	<ul style="list-style-type: none"> a. Functional description of control panel membrane switches expanded (Section 1). b. General information, reloading fanfold and cut sheet forms, print stand paper loading, and ribbon cassette replacement information added (Section 2). c. Operating procedure steps improved and expanded (Par. 3.2). d. New self-test printout format documented (Par. 3.3). e. Troubleshooting guide is expanded (Par. 4.2). f. New universal print stand dimensions documented (Fig. 6-1) (Ref. PCP 37403511/A.A). g. New mounting hardware described in printer setup procedure (Par. 6.4) (Ref. PCP 37403511-9A01). h. Tables in Figs. 7-1 and 7-2 redrawn for improved user readability (Par. 7.2). i. Parallel interface timing diagram updated (Fig. 8-1). j. Multipass feature added to description of Horizontal Pitch (Section 9). k. Printer weight is changed (Section 9). l. Detailed descriptions of control codes added (Par. 10.2). m. Escape sequence information is modified and expanded (Par. 10.3). n. Entirely new section on programming character sets/graphics added (Section 11). o. New options and accessories documented (Section 12). p. Data Link usage information (formerly in 351 Technical Manual) has been expanded and is now included in the Users Manual (Appendix A).
B2 (April 1984)	a. Incorporated PCP 37403511-9B11 and PCP 37403511-9B12.

TABLE OF CONTENTS

INTRODUCTION	I
OPERATORS INFORMATION	II
SECTION 1—CONTROLS AND INDICATORS	
1.1 GENERAL	1-1
1.2 PRINTER MECHANISM CONTROLS AND SWITCHES	1-1
1.3 CONTROL PANEL SWITCHES AND INDICATORS	1-2
1.4 CONTROL PANEL DIP SWITCHES	1-3
SECTION 2—PAPER LOADING/RIBBON REPLACEMENT	
2.1 GENERAL	2-1
2.2 INITIAL LOADING, FANFOLD FORMS	2-1
2.3 RELOADING FANFOLD FORMS	2-2
2.4 INITIAL LOADING, CUT SHEET FORMS	2-2
2.5 RELOADING CUT SHEET FORMS	2-4
2.6 PRINT STAND PAPER LOADING	2-4
2.7 RIBBON CASSETTE REPLACEMENT	2-4
2.8 PRINT HEAD IMPRESSION ADJUSTMENT	2-5
SECTION 3—PRINTER OPERATION	
3.1 OPERATING NOTES	3-1
3.2 OPERATING PROCEDURES	3-1
3.3 SELF-TEST	3-2
SECTION 4—OPERATOR MAINTENANCE	
4.1 PREVENTIVE MAINTENANCE	4-1
4.2 TROUBLESHOOTING GUIDE	4-2
SECTION 5—REMOVAL/REPLACEMENT	
5.1 GENERAL	5-1
5.2 REMOVAL COVER ASSEMBLIES	5-1
5.3 REMOVAL/REPLACEMENT PRINT HEAD ASSEMBLY	5-2
5.4 REMOVAL/REPLACEMENT INPUT FUSE	5-3
INSTALLATION, INTERFACE & SPECIFICATIONS	III
SECTION 6—INSTALLATION	
6.1 GENERAL	6-1
6.2 PRINTER INSPECTION	6-1
6.3 SITE CONSIDERATIONS	6-1
6.4 PRINTER SET-UP	6-2
SECTION 7—PRINTER FEATURES	
7.1 PRINTER FEATURES SELECTION	7-1
7.2 PRINTER FEATURES DIP SWITCH S1	7-1
7.3 PRINTER FEATURES DIP SWITCH S2	7-1
7.4 ACCESSING DIP SWITCHES S3 AND S4	7-3
7.5 PRINTER FEATURES DIP SWITCH S3	7-3
7.6 PRINTER FEATURES DIP SWITCH S4	7-4
7.7 DATA STROBE SWITCH	7-5
7.8 FACTORY SETTINGS	7-5

SECTION 8—INTERFACE INFORMATION	
8.1 GENERAL INFORMATION	8-1
8.2 PARALLEL INTERFACE CONNECTION	8-1
8.3 SERIAL INTERFACE CONNECTION	8-2

SECTION 9—SPECIFICATIONS	
9.1 MODEL 351 SPECIFICATIONS	9-1

PROGRAMMING INFORMATION IV

SECTION 10—PROGRAMMING INFORMATION	
10.1 GENERAL PROGRAMMING INFORMATION	10-1
10.2 CONTROL CODES	10-1
10.3 ESCAPE SEQUENCES	10-2
10.4 PROGRAMMING CONSIDERATIONS	10-6

SECTION 11—PRINT GENERATION	
11.1 GENERAL	11-1
11.2 PRIMARY CHARACTER SET	11-1
11.3 ALTERNATE CHARACTER SET	11-1
11.4 MULTI-PASS CHARACTER SET	11-3
11.5 GRAPHICS	11-4

OPTIONS AND ACCESSORIES V

SECTION 12—OPTIONS AND ACCESSORIES	
12.1 GENERAL	12-1
12.2 OPTIONS	12-1
12.3 ACCESSORIES	12-2

APPENDIX VI

APPENDIX A—DATA LINK USAGE	
A.1 GENERAL	A-1
A.2 LINK PROM FUNCTIONS	A-1
A.3 LINK PROM FORMATTING	A-3
A.4 LINK PROM USAGE	A-5
A.5 MAIN PROGRAM ROUTINES	A-11
A.6 COMMON FUNCTIONS	A-12
A.7 SELF-TEST ROUTINE (DLSTLD)	A-13
A.8 ERROR ROUTINE	A-13
A.9 SINGLE-STEP OPTION	A-13
A.10 SWITCH SET-UP	A-13
A.11 INPUT/OUTPUT LOCATIONS	A-15

APPENDIX B—MODEL 351-3 & 351-4 PRINTERS	
B.1 MODEL 351-3 PRINTER	B-1
B.2 MODEL 351-4 PRINTER	B-1
B.3 ESCAPE SEQUENCES	B-1
B.4 DOCUMENTATION	B-1

INTRODUCTION

The Model 351 printer is a high quality product with many features to help you perform your job more efficiently. Some of the more significant features of the printer are:

- 200 CPS, "Data Processing" Printing
- Serial or Parallel Data Input
- Operator Selectable Forms Length
- Pin Addressable Graphics
- Self-Test Capability
- Audible Alarm
- Demand Document Capability
- Fanfold or Cut Sheet Forms Handling
- Forward or Reverse Paper Motion (Cut sheet mode)
- Selectable Vertical Pitch
- Selectable Proportional Printing
- Selectable Multipass Proportional Printing

The printer is lightweight, easy to install and operate, and compatible with both EIA and ANSI standards.

This manual provides the necessary information to install, program, operate, and maintain your Model 351 printer.

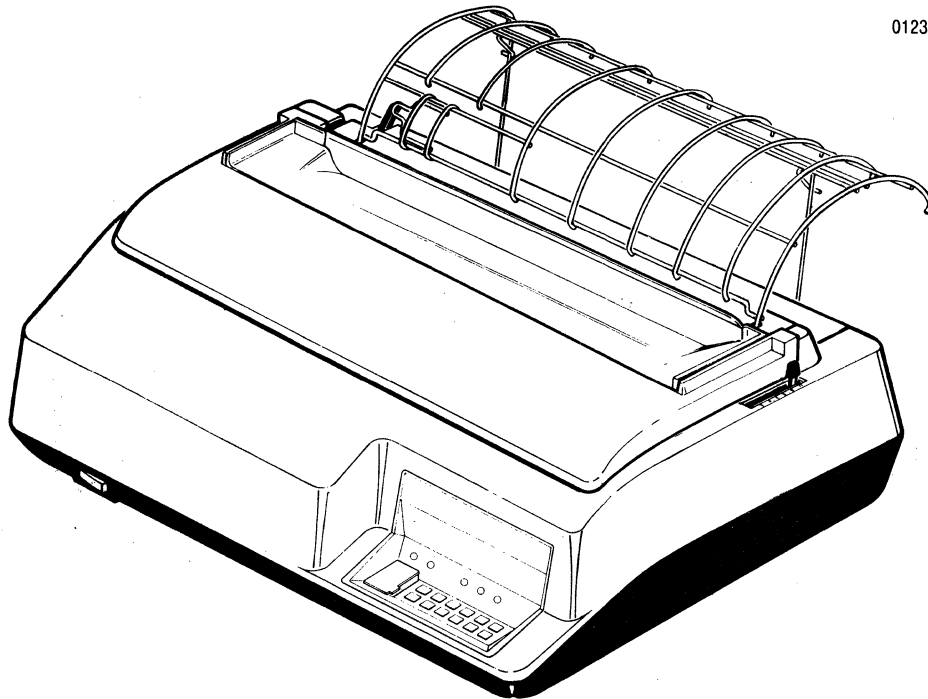

Introduction

CONTENTS

Section 1	Controls and Indicators
Section 2	Paper Loading/Ribbon Replacement
Section 3	Printer Operation
Section 4	Operator Maintenance
Section 5	Removal/Replacement

Operators Information

SECTION 1

CONTROLS AND INDICATORS

1.1 GENERAL

As the operator of the Model 351 printer, you will be printing a variety of jobs. The controls and indicators provide the communications path between you and the printer. Using the controls and indicators, you set-up the printer to print a specific form, sheet, etc. All operator controls and indicators are located on either the printer mechanism or the control panel.

1.2 PRINTER MECHANISM CONTROLS AND SWITCHES

Figure 1-1 illustrates the printer mechanism controls and switches with which an operator should be familiar. A brief description of each control and switch is provided below.

POWER SWITCH—When placed in the ON position, applies power to the printer circuits.

COVER INTERLOCK SWITCH—A safety feature which automatically stops the printing when the top cover is opened.

FORMS LEVER—The forms lever can be set to any one of three positions: LOAD, SHEET or FORMS.

NOTE

Ensure the carriage is at the extreme left margin before moving the forms lever.

Load—In this position, either fanfold forms or cut sheet forms can be loaded into the printer.

Sheet—In this position, the printer is set-up to handle cut sheet (non-tractor type) forms.

Forms—In this position, the printer is set-up to handle continuous fanfold forms.

PAPER EMPTY SWITCH—Detects a paper empty condition, automatically stops the printer and sounds the audio alarm.

PRINT HEAD ADJUSTMENT LEVER—Adjusts the print head in or out for optimum print quality.

AUDIO ALARM—Sounds a one second tone on a paper empty condition, fault condition, receipt of a BEL code, or when the **SET TOF, 16.5 CPI,** or **MULTIPASS** keys are pressed.

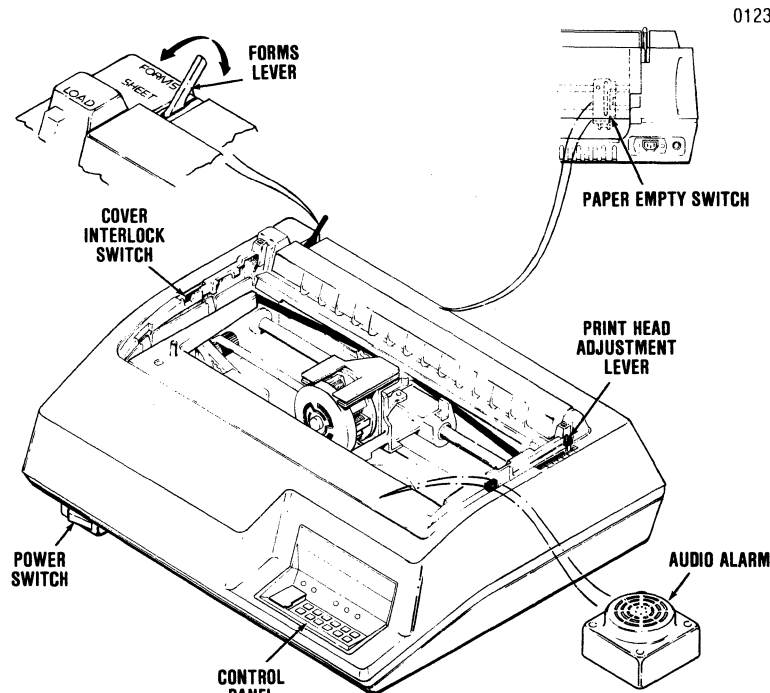

Figure 1-1 Printer Mechanism Controls and Switches

1.3 CONTROL PANEL SWITCHES AND INDICATORS

The control panel switches set specific features in the printer. All switches are membrane switches which are activated by lightly pressing the switch. Figure 1-2 illustrates the control panel switches and indicators, and a brief description of each switch and indicator is provided below:

CONTROL PANEL SWITCHES

SELECT

Places the printer on line (Selected) or off line (Deselected). When selected, data reception and printer action are allowed. When deselected, printer action will stop, and the **SELECT** LED will be extinguished. On a "paper empty" condition, pressing the **SELECT** switch will override the deselect mode and will allow the printer to continue printing to the end of the form.

CUT SHEET MODE

Places the printer either in or out of the cut sheet mode as indicated by the **CUT SHEET** indicator.

CUT SHEET INSERT

When in the Cut Sheet Mode, loads the sheet into the printer.

FORM FEED

Advances the form to the next top of form or ejects a cut sheet form from the printer.

SET TOF

Sets the current print line as the top of form.

LF

Advances the paper forward one line. If the switch is pressed for longer than 1/2 second, line feeds are repeated until the switch is released.

PAPER FWD

Advances fanfold paper forward in steps of 1/120 an inch and cut sheet forms in steps of 1/108 an inch. If the switch is pressed for longer than 1/2 second, paper moves forward until the switch is released.

PAPER REV

Performs the same function as the **PAPER FWD** switch except it moves paper in the reverse direction.

NOTE

Fanfold forms should not be reversed more than one half inch as paper handling problems may occur.

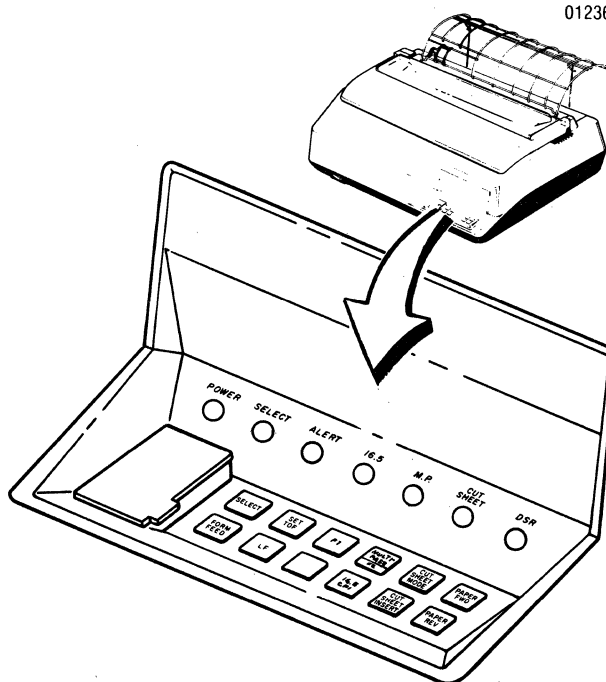

Figure 1-2 Control Panel Switches and Indicators

16.5 CPI

When actuated, this switch will change the horizontal pitch from 10 cpi (or 12 cpi) to 16.5 cpi, or from 16.5 cpi to 10 cpi. This is also true for expanded printing; when the 16.5 cpi switch is actuated, the horizontal pitch will change from 5 cpi (or 6 cpi) to 8.25 cpi, or from 8.25 cpi to 5 cpi. The **16.5 CPI** switch is active when the printer is either selected or deselected. (When selected, it is only active between lines.) Depressing the switch will sound the audio alarm.

MULTI-PASS F2

The function of this switch is to start or stop multipass proportional printing in the unidirectional mode. The multipass switch is active only when the printer is deselected and not in the graphics mode. Changing into or out of the multipass mode will sound the audio alarm.

F1

This switch enables the user defined Link Prom when the Link Prom has been installed in the printer in place of the Multipass Prom.

NOTE

The printer can use either the Multipass function or the Data Link capability but not both at the same time. The type of operation allowed will depend on which PROM device is installed in the printer.

CONTROL PANEL INDICATORS

NOTE

When any of the following indicators are lit, that particular function is selected.

POWER Indicator—Indicates power is applied to the printer circuits.

SELECT Indicator—Indicates that the printer is in the Select Mode.

ALERT Indicator—Indicates a paper empty condition. During a fault condition, the ALERT indicator will blink. When in Cut Sheet mode, the ALERT indicator will not indicate a paper out condition.

16.5 Indicator—Indicates that the horizontal pitch is set to 16.5 cpi.

M.P. Indicator—Indicates the printer is in the multipass proportional mode.

CUT SHEET Indicator—Indicates the printer is in the Cut Sheet mode.

DSR Indicator—Indicates the printer is in the serial mode of operation and that the RS-232C interface line CC (Data Set Ready) is active (+V) or not connected to the data set.

1.4 CONTROL PANEL DIP SWITCHES

The control panel contains 2 eight-position dip switches used for operator selection of country character sets, auto line feed, form length, horizontal pitch, and baud rate. The setting of the dip switches for specific functions is detailed in Section 7, Printer Features. The printer feature section also covers the settings of the internal dip switches. Figure 1-3 illustrates the location of the dip switches on the control panel.

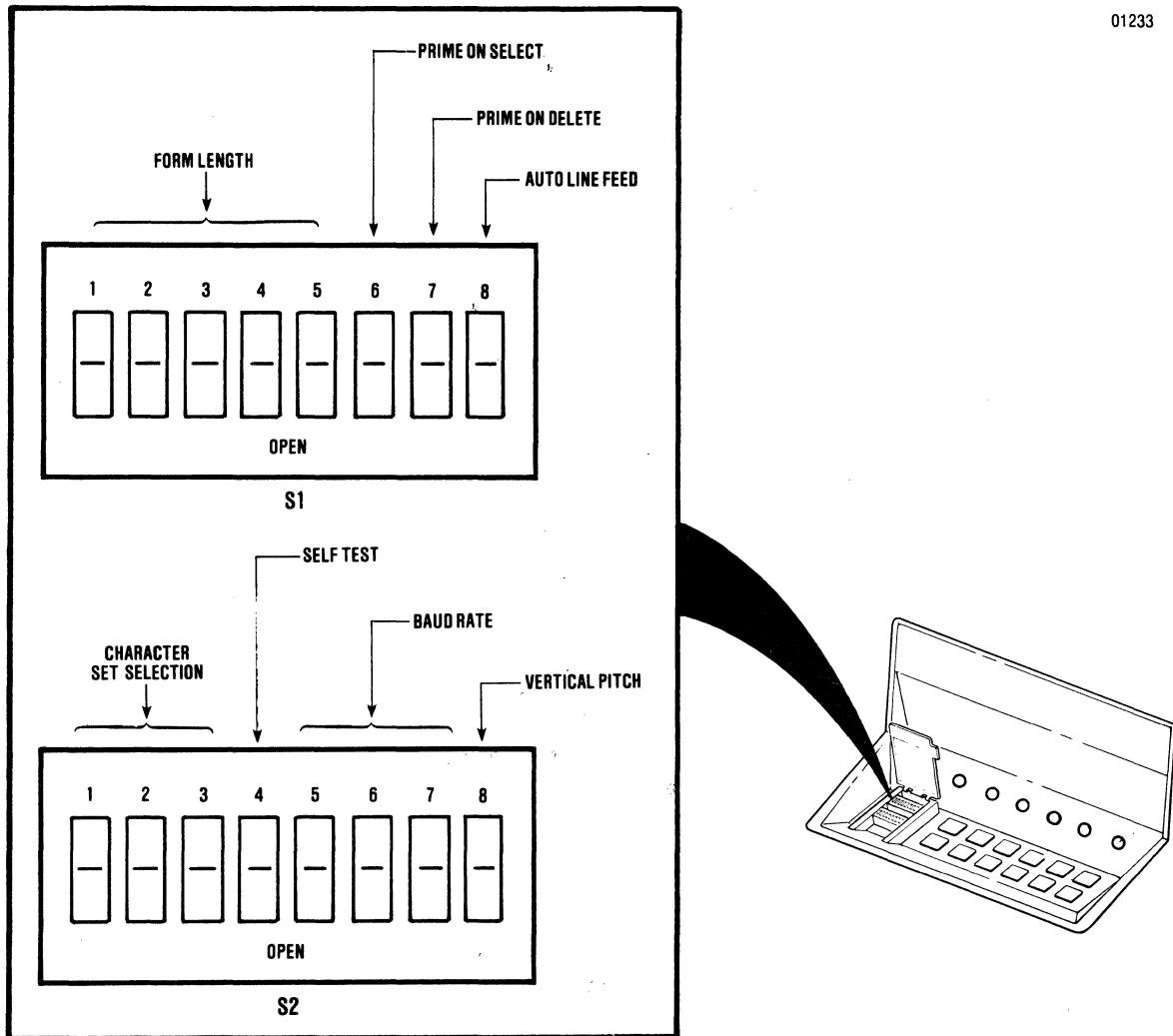

01233

Figure 1-3 Control Panel Dip Switches

SECTION 2

PAPER LOADING/ RIBBON REPLACEMENT

2.1 GENERAL

This section details the procedures for loading paper, replacing the ribbon, and adjusting the print head for optimum print quality. Two types of paper, either continuous fanfold forms or cut sheet forms, can be installed in the printer. The specifications of both forms are defined in Section 9. The paper loading, ribbon replacement, and head adjustment procedures are described in the following paragraphs.

NOTE

The following procedures are performed from the front of the printer.

2.2 INITIAL LOADING, FANFOLD FORMS

The following procedure describes the first time loading of fanfold forms once the printer has been installed. The procedure is for both single and multi-part forms. Refer to Figure 2-1 and perform the following steps:

1. Move the forms lever to the "LOAD" position.
2. Pull the head adjustment lever towards the front of the printer to its maximum position.
3. Unsnap and lift the rear cover from the printer.
4. Locate the left and right pin feed tractors.
5. Loosen the tractor locking lever on the left pin feed tractor and slide the tractor to the left-most position. Tighten the locking lever to secure the tractor.
6. Place the forms to be installed slightly behind the printer.
7. Open the left and right tractor paper guides.
8. Install the forms onto the drive pins of the left pin feed tractor and close the left tractor paper guide.

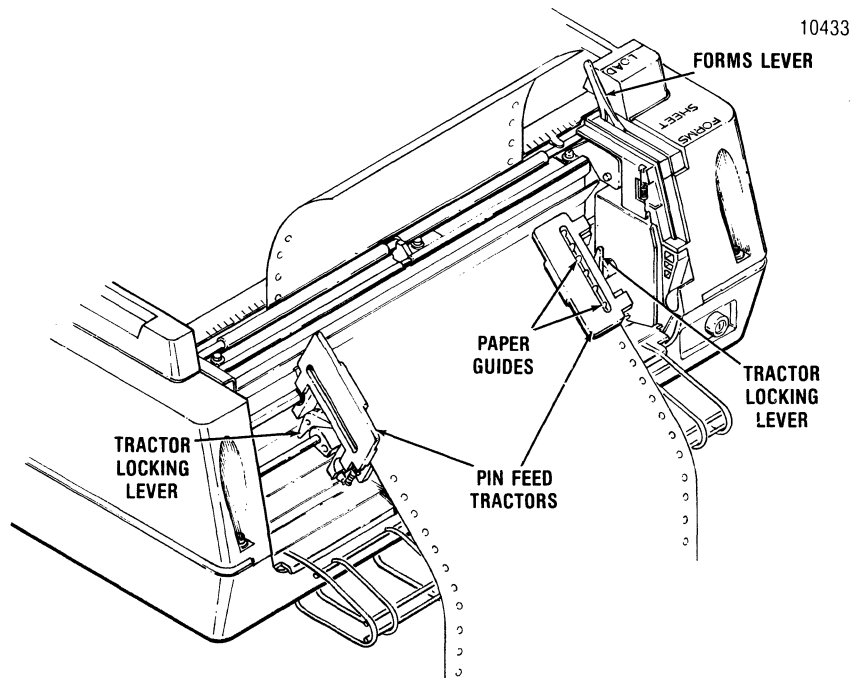

Figure 2-1 Loading Fanfold Forms

9. Loosen the tractor locking lever on the right pin feed tractor and slide the tractor left or right to accommodate the forms width. Once adjusted, tighten the locking lever to secure the tractor.
10. Install the forms onto the drive pins of the right pin feed tractor and close the paper guide.
11. Turn the printer power on and depress the LF switch which loads the forms into the printer.
12. Release the LF switch at the desired print position.
13. Press the SET TOF switch to set the current print line as the top of form.
14. Place the forms lever in the "FORMS" position.
15. Perform the print head impression adjustment per paragraph 2.7.
16. Install the rear cover retaining tabs into the body cover slots and snap the top closed.
17. Press the SELECT switch to enable the printer to receive data.

2.3 RELOADING FANFOLD FORMS

The Model 351 operates until the last form passes through the paper empty switch on the left pin feed tractor. When out of paper, printing stops, the ALERT indicator lights, the audio alarm sounds, and the printer deselects. To reload forms refer to Figure 2-1 and perform the following procedure.

NOTE

To move the last form through the printer on a paper empty condition hold the **SELECT** switch depressed. This will allow the printer to print the last form. **DO NOT TURN POWER OFF TO RELOAD FORMS.**

1. Move the forms lever to the "LOAD" position.

NOTE

Before performing step 2 note the position of the head adjustment lever. If installing the same form as previous, return the lever to this position once the form is installed.

2. Pull the head adjustment lever towards the front of the printer to its maximum position.
3. Unsnap and lift the rear cover from the printer.
4. Open the left and right tractor guides and load the forms onto the drive pins of the tractors.
5. Close the tractor guides.
6. Hold the LF switch depressed, which loads paper up into the printer.
7. Release the LF switch at the desired print position.
8. Place the forms lever in the "FORMS" position.
9. Return head adjustment lever to its original position or, if a different size form is installed perform the print head impression adjustment per paragraph 2.7.
10. Install the rear cover retaining tabs into the body cover slots and snap the top closed.
11. Press the **SELECT** switch to enable the printer to print.

2.4 INITIAL LOADING, CUT SHEET FORMS

The Model 351 is designed to allow semi-automatic insertion of cut sheet forms and documents. The following procedure describes the first time loading of either single or multi-part cut sheet forms once the printer has been installed. Refer to Figure 2-2 and perform the following steps:

1. Unsnap the top portion of the rear cover and place in the open position and slide the left/right pin feed tractors to the extreme left/right positions. Once tractors are positioned snap the rear cover closed.

2. Set the form length for the cut sheet by making the appropriate selection on DIP switch S1 (see Section 7, paragraph 7.2).
3. Turn the printer power on and enter into the cut sheet mode by pressing the CUT SHEET MODE switch on the control panel.

NOTE

Form length can optionally be set by sending the form length escape sequence code. Refer to paragraph 10.3.

4. Move the forms lever to the "LOAD" position.
5. Move the print head away from the platen by pulling the head adjustment lever back to its maximum position.
6. Insert the bottom edge of the cut sheet form between the rollers on the column scale and the paper drive roller until the mechanical stops prevent further insertion.

7. Slide the cut sheet form left or right until the left edge of the form aligns with the right edge of the cut sheet load indicator.
8. Move the left hand forms guide on the wire paper rack outlet to the left or right for proper form alignment.
9. Place the forms lever in the "SHEET" position.
10. Press the **CUT SHEET INSERT** switch on the control panel which loads the cut sheet form into the printer.
11. Perform the print head impression adjustment per paragraph 2.7.
12. Press the **SELECT** switch to enable the printer to receive data.

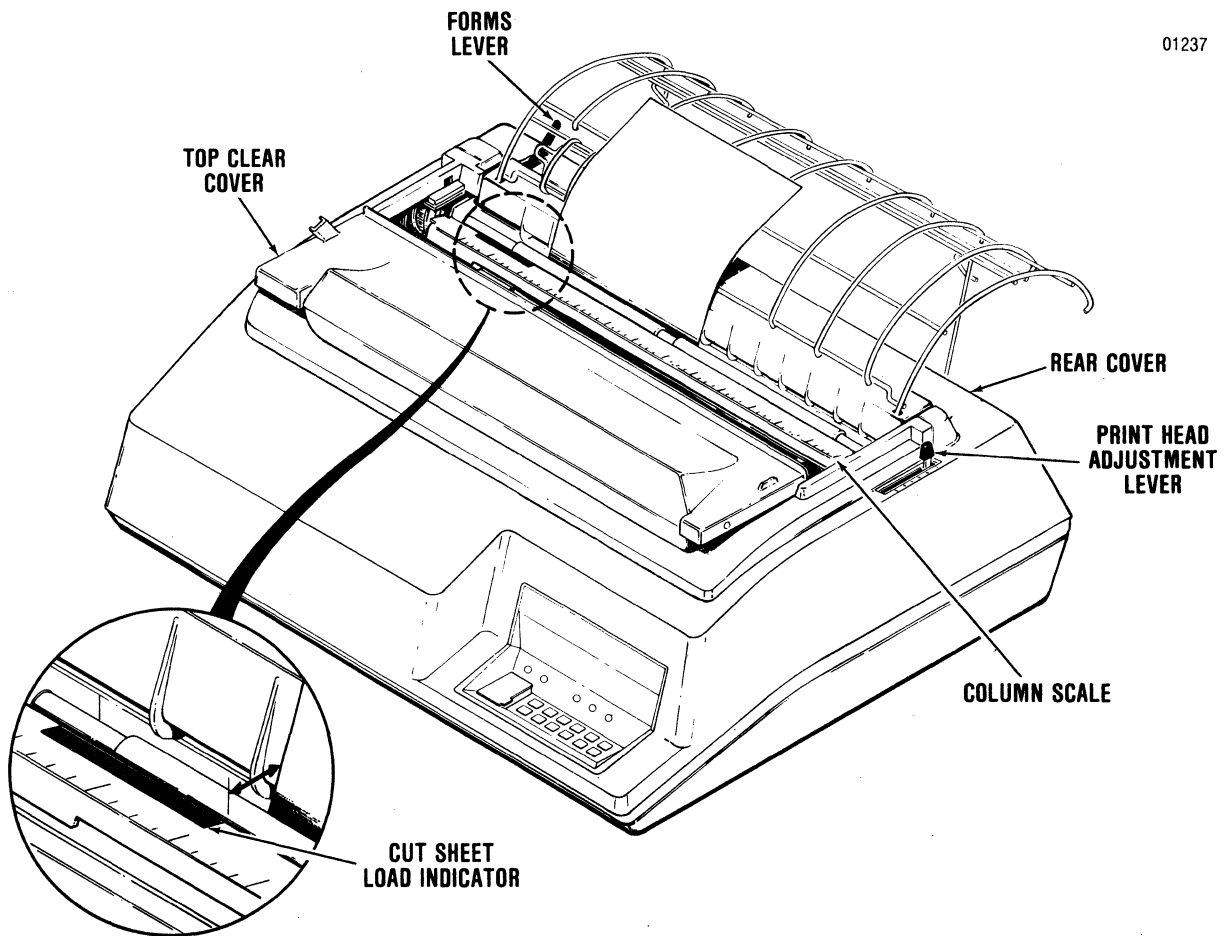

01237

Figure 2-2 Loading Cut Sheet Forms

2.5 RELOADING CUT SHEET FORMS

In the Cut Sheet Mode, the Model 351 prints the cut sheet form and then moves the form through the printer. To insert additional cut sheet forms once in the Cut Sheet Mode, refer to Figure 2-2 and perform the following steps:

NOTE

If inserting the same type of form as was previously used, skip steps 2 and 8 in the following procedure. **DO NOT TURN POWER OFF TO RELOAD FORMS.**

1. Deselect the printer.
2. Pull the head adjustment lever towards the front of the printer to its maximum position.
3. Move forms lever to the "LOAD" position.
4. Insert the bottom edge of the cut sheet form between the rollers on the column scale and the paper drive roller until the mechanical stops prevent further insertion.
5. Slide the cut sheet form left or right until the left edge of the form aligns with the right edge of the cut sheet load indicator.
6. Place the forms lever in the "SHEET" position.
7. Press the **CUT SHEET INSERT** switch on the control panel which loads the cut sheet form into the printer.
8. If a different size form is installed, perform the print head adjustment per paragraph 2.8.
9. Press the **SELECT** switch to enable the printer to receive data.

2.6 PRINT STAND PAPER LOADING

Printers equipped with the optional print stand are loaded with fanfold forms by performing the following steps:

1. Refer to Figure 2-3 and position an open box of fanfold forms at the base of the print stand, as shown in the illustration.
2. Refer to paragraph 2.2 and perform steps 1 through 7.
3. Guide the fanfold paper out of the box, through the opening between the wirebasket and the stand uprights, over the lower paper guide and onto the drive pins of the left pin feed tractor.

4. Close the left tractor paper guide.
5. Refer to paragraph 2.2 and perform steps 9 through 17.

01105-A

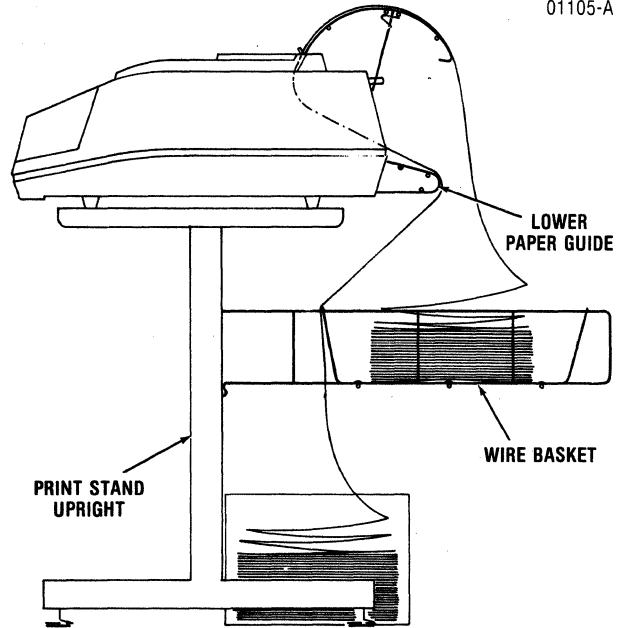

Figure 2-3 351 Printer Paper Travel

2.7 RIBBON CASSETTE REPLACEMENT

The Model 351 contains a 70 yard long life ribbon cassette. To replace the cassette, refer to Figure 2-4 and perform the following steps:

1. Lift the top cover up and off the printer.
2. Unsnap the top portion of the rear cover and place in the open position.
3. Ensure the print head is at the extreme left margin.
4. Place the forms lever in the "LOAD" position.
5. Lift the column scale into the up position.

NOTE

Before performing step 6 note the position of the head adjustment lever. Once the new ribbon cassette has been installed return the lever to this position

6. Move the print head away from the platen by pulling the head adjustment lever back to its maximum position.
7. Remove the ribbon guide from the front of the print head by squeezing together the two tabs at the top of the ribbon guide and lifting upward.

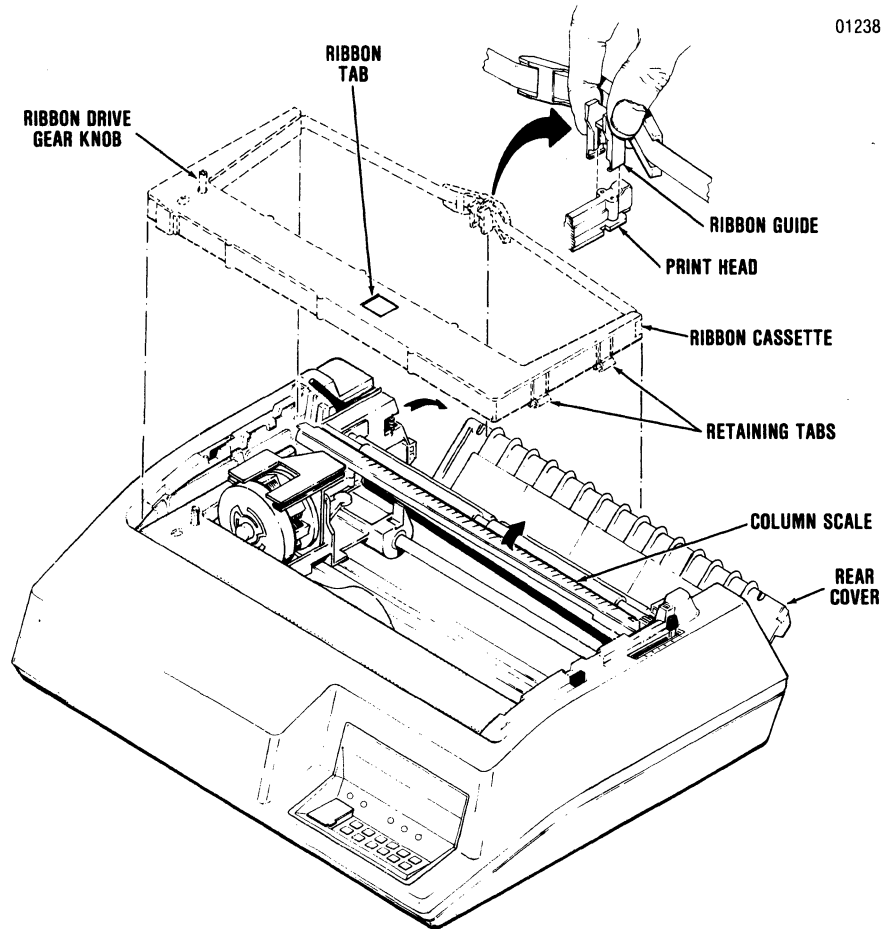

Figure 2-4 Ribbon Cassette Replacement

8. Lift the used ribbon cassette and attached ribbon guide up and out of the printer.
9. Snap the two left and two right retaining tabs of the new ribbon cassette into the four slots on the left and right side frames.
10. Install the new ribbon guide by squeezing the two tabs at the top of the guide and pushing the guide downward onto the front of the print head.
11. Pull the ribbon tab off the ribbon cassette.
12. Rotate the ribbon drive gear knob counter-clockwise several turns to ensure the ribbon is feeding properly.
13. Place the column scale in the down position and move the forms lever to the type of form (SHEET or FORMS) being printed.
14. Lift and snap the rear cover closed.
15. Insert the front lip of the top cover under the body cover and close the top cover.

2.8 PRINT HEAD IMPRESSION ADJUSTMENT

The print head can be adjusted in or out for different form thickness to provide optimum print quality. To adjust the print head impression, refer to Figure 2-5 and perform the following steps:

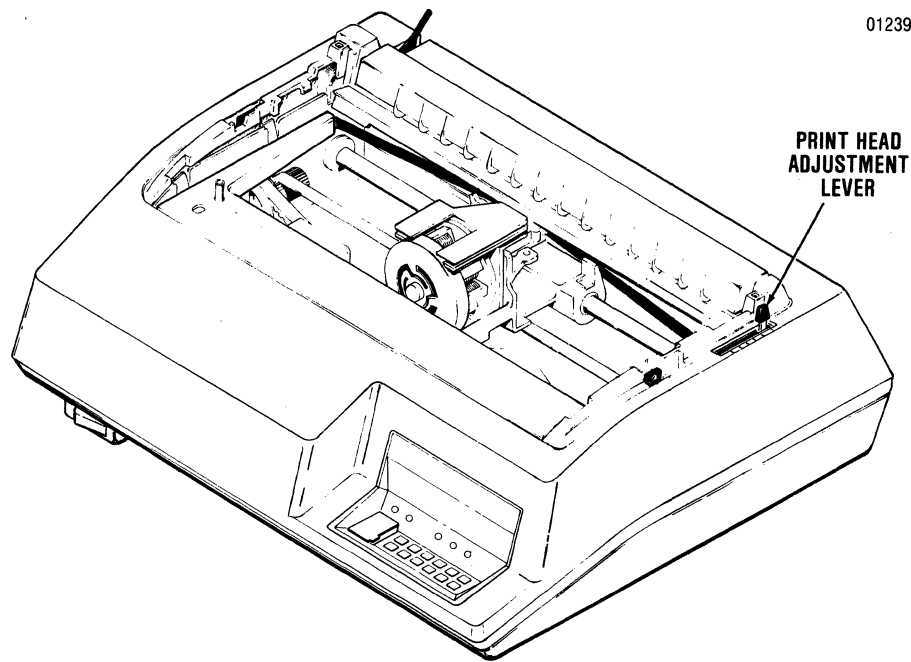

Figure 2-5 Print Head Impression Adjustment

1. Ensure paper is loaded and the forms lever is in the "FORMS" or "SHEET" position.
2. While manually moving the print head from side to side move the head adjustment lever in or out until the smudging occurs or paper rippling occurs, then, move the head adjustment lever back one position.
3. Initiate a self-test printout by placing self-test dip switch S2-4 in the "ON" position and pressing the **SELECT** button.
4. Check the printout to ensure good clean print quality. If the print is too dark or too light, adjust the print head in or out as required. Return dip switch S2-4 to the "OFF" position after testing.

SECTION 3

PRINTER OPERATION

3.1 OPERATING NOTES

Before operating the printer, check the following to ensure proper operation.

- Always plug the printer into a 3-wire grounded outlet.
- Ensure all covers are closed and secured before operation.
- Never operate the printer without paper installed.
- Avoid leaning or placing objects on any part of the printer.

3.2 OPERATING PROCEDURES

Operation of the printer involves power-up of the printer, deselect mode of operation, select mode of operation and power-down of the printer. The following procedures describe how to enter into each mode and the functions that can be performed while in that mode.

POWER-UP—To power-up the printer, first set all dip switches (see Section 7 for dip switch settings), ensure that paper is loaded, then set the **POWER** switch to the “ON” position. Placing the **POWER** switch in the “ON” position lights the **POWER** indicator and places the printer in the deselect mode. On power-up the printer automatically performs the internal self-test operation.

DESELECT MODE—The printer is deselected by any one of the following actions:

1. Setting the **POWER** switch to the “ON” position.
2. Pressing the **SELECT** switch on the control panel while the printer is selected.
3. Receiving a DC3 control code from the input device or computer while the printer is selected.
4. Generating a paper empty condition while using fanfold forms.

When the printer is deselected, the **POWER** indicator is lit and the **SELECT** indicator is extinguished. In the deselect mode the following functions can be performed.

1. Select the printer locally by pressing the **SELECT** switch, or remotely by receiving a DC1 control code from the input device or computer.
2. Set the current line as the top of form position by pressing the **SET TOF** switch on the control panel.
3. Move the form forward by pressing the **LF** switch.
4. Move the form to the next sequential top of form by pressing the **FORM FEED** switch.
5. Enter or exit the Cut Sheet Mode as long as fanfold forms are removed.
6. Enter multipass mode by depressing **MULTIPASS** switch.

DESELECT OR SELECT MODE—The following functions can be performed in either the Deselect or the Select mode:

1. Move the paper in either the forward or reverse direction by pressing either the **PAPER FWD** or **PAPER REV** switch on the control panel.

NOTE

The top of form and vertical tab positions are offset by the number of steps moved when the **PAPER FWD** or **PAPER REV** switches are actuated.

2. Insert a cut sheet form, if in the Cut Sheet Mode.
3. Enter 16.5 CPI mode by depressing **16.5 CPI** switch.

SELECT MODE—The printer is selected by either of the following two methods:

1. Pressing the **SELECT** switch on the control panel while the printer is deselected.

2. Receiving a DC1 control code from the input device or computer while the printer is deselected.

When the printer is selected, the **POWER** and **SELECT** indicators are lit. In this mode of operation, the printer performs the following functions:

1. Receives data from the input device and prints the data.
2. Advances the paper by receiving paper motion control codes from the input device.

POWER-DOWN—To power-down the printer, deselect the unit and set the **POWER** switch to the “OFF” position.

3.3 SELF-TEST

The printer performs two self-test operations. The first is an internal self-test which is performed on power-up of the printer. The second self-test is preset by the operator placing the **SELF TEST** switch on the operator control panel-mounted dip

switch S2 while the printer is in the powered off state. (The test is performed after power up.)

INTERNAL SELF-TEST—On power-up, the printer performs an internal self-test to check and verify the printer logic. If any problems are located, the control panel indicators, listed in Table 3-1, blink until the **SELECT** switch is pressed, then all checks are retested. The audio alarm sounds when a problem is first detected. If an error condition still exists after reselecting the printer, record the error indication and call for service.

OPERATOR SELF-TEST—This self-test feature is set by placing the **SELF-TEST** dip switch on the operator control panel to the ON position before the printer is powered on. The test will print out the entire character set(s) and binary codes that indicate printer configuration. Test data is reprinted each time the printer is selected. A sample printout is shown in Figure 3-1. Return the **SELF-TEST** switch to the OFF position after the test is performed.

Table 3-1 Control Panel Fault Indicators

AREA CHECKED	LED INDICATORS		
	SELECT	ALERT	CUT SHEET
CRC 1			BLINKING
CRC 2	BLINKING		BLINKING
RAM 1		BLINKING	BLINKING
RAM 2	BLINKING	BLINKING	
HEAD JAM	BLINKING		
INTERLOCK		BLINKING	
CPU	BLINKING	BLINKING	BLINKING

10 CPI { USA !"#%&'()*+,-./0123456789:;<=>?@ABCDEFGHIJKLMNopqrstuvwxyz[\]^_`abcdefghijklmnopqrstuvwxyz{|}~
 FRA !"£\$%&'()*+,-./0123456789:;<=>?aABCDEFGHIJKLMNopqrstuvwxyz°ç§^_`abcdefghijklmnopqrstuvwxyzéùè`
 UK !"£\$%&'()*+,-./0123456789:;<=>@ABCDEFGHIJKLMNopqrstuvwxyz[\]^_`abcdefghijklmnopqrstuvwxyz{|}~
 GER !"#%&'()*+,-./0123456789:;<=>?SABCDEFgHIJKLMNopQRSTUVWXYzAöÜ^_`abcdefghijklmnopqrstuvwxyzääüß
 ITL !"£\$%&'()*+,-./0123456789:;<=>?SABCDEFgHIJKLMNopQRSTUVWXYz°é|^_`abcdefghijklmnopqrstuvwxyzàèì
 S/F !"£\$%&'()*+,-./0123456789:;<=>?EABCDEFgHIJKLMNopQRSTUVWXYzAöAÜ_`abcdefghijklmnopqrstuvwxyzääü
 D/N !"£\$%&'()*+,-./0123456789:;<=>?@ABCDEFGHIJKLMNopQRSTUVWXYzÆØAÜ_`abcdefghijklmnopqrstuvwxyzæøäü
 ESP !"£\$%&'()*+,-./0123456789:;<=>?SABCDEFgHIJKLMNopQRSTUVWXYzIñ¿áé`abcdefghijklmnopqrstuvwxyzíñó
 ALT !"#%&'()*+,-./0123456789:;<=>?@ABCDEFGHIJKLMNopQRSTUVWXYz[\]^_`abcdefghijklmnopqrstuvwxyz{|}~

12 CPI { USA !"#%&'()*+,-./0123456789:;<=>?@ABCDEFGHIJKLMNopQRSTUVWXYz[\]^_`abcdefghijklmnopqrstuvwxyz{|}~
 FRA !"£\$%&'()*+,-./0123456789:;<=>?aABCDEFGHIJKLMNopQRSTUVWXYz°ç§^_`abcdefghijklmnopqrstuvwxyzéùè`
 UK !"£\$%&'()*+,-./0123456789:;<=>@ABCDEFGHIJKLMNopQRSTUVWXYz[\]^_`abcdefghijklmnopqrstuvwxyz{|}~
 GER !"#%&'()*+,-./0123456789:;<=>?SABCDEFgHIJKLMNopQRSTUVWXYzAöÜ^_`abcdefghijklmnopqrstuvwxyzääüß
 ITL !"£\$%&'()*+,-./0123456789:;<=>?SABCDEFgHIJKLMNopQRSTUVWXYz°é|^_`abcdefghijklmnopqrstuvwxyzàèì
 S/F !"£\$%&'()*+,-./0123456789:;<=>?EABCDEFgHIJKLMNopQRSTUVWXYzAöAÜ_`abcdefghijklmnopqrstuvwxyzääü
 D/N !"£\$%&'()*+,-./0123456789:;<=>?@ABCDEFGHIJKLMNopQRSTUVWXYzÆØAÜ_`abcdefghijklmnopqrstuvwxyzæøäü
 ESP !"£\$%&'()*+,-./0123456789:;<=>?SABCDEFgHIJKLMNopQRSTUVWXYzIñ¿áé`abcdefghijklmnopqrstuvwxyzíñó
 ALT !"#%&'()*+,-./0123456789:;<=>?@ABCDEFGHIJKLMNopQRSTUVWXYz[\]^_`abcdefghijklmnopqrstuvwxyz{|}~

16.5 CPI { USA !"#%&'()*+,-./0123456789:;<=>?@ABCDEFGHIJKLMNopQRSTUVWXYz[\]^_`abcdefghijklmnopqrstuvwxyz{|}~
 FRA !"£\$%&'()*+,-./0123456789:;<=>?aABCDEFGHIJKLMNopQRSTUVWXYz°ç§^_`abcdefghijklmnopqrstuvwxyzéùè`
 UK !"£\$%&'()*+,-./0123456789:;<=>@ABCDEFGHIJKLMNopQRSTUVWXYz[\]^_`abcdefghijklmnopqrstuvwxyz{|}~
 GER !"#%&'()*+,-./0123456789:;<=>?SABCDEFgHIJKLMNopQRSTUVWXYzAöÜ^_`abcdefghijklmnopqrstuvwxyzääüß
 ITL !"£\$%&'()*+,-./0123456789:;<=>?SABCDEFgHIJKLMNopQRSTUVWXYz°é|^_`abcdefghijklmnopqrstuvwxyzàèì
 S/F !"£\$%&'()*+,-./0123456789:;<=>?EABCDEFgHIJKLMNopQRSTUVWXYzAöAÜ_`abcdefghijklmnopqrstuvwxyzääü
 D/N !"£\$%&'()*+,-./0123456789:;<=>?@ABCDEFGHIJKLMNopQRSTUVWXYzÆØAÜ_`abcdefghijklmnopqrstuvwxyzæøäü
 ESP !"£\$%&'()*+,-./0123456789:;<=>?SABCDEFgHIJKLMNopQRSTUVWXYzIñ¿áé`abcdefghijklmnopqrstuvwxyzíñó
 ALT !"#%&'()*+,-./0123456789:;<=>?@ABCDEFGHIJKLMNopQRSTUVWXYz[\]^_`abcdefghijklmnopqrstuvwxyz{|}~

PROPORTIONAL PRINTING { USA !"#\$%&'()*+,-./0123456789:;<=>?@ABCDEFGHIJKLMNopQRSTUVWXYz[\]^_`abcdefghijklmnopqrstuvwxyz{|}~
 FRA !"£\$%&'()*+,-./0123456789:;<=>?aABCDEFGHIJKLMNopQRSTUVWXYz°ç§^_`abcdefghijklmnopqrstuvwxyzéùè`
 UK !"£\$%&'()*+,-./0123456789:;<=>@ABCDEFGHIJKLMNopQRSTUVWXYz[\]^_`abcdefghijklmnopqrstuvwxyz{|}~
 GER !"#\$%&'()*+,-./0123456789:;<=>?SABCDEFgHIJKLMNopQRSTUVWXYzAöÜ^_`abcdefghijklmnopqrstuvwxyzääüß
 ITL !"£\$%&'()*+,-./0123456789:;<=>?SABCDEFgHIJKLMNopQRSTUVWXYz°é|^_`abcdefghijklmnopqrstuvwxyzàèì
 S/F !"£\$%&'()*+,-./0123456789:;<=>?EABCDEFgHIJKLMNopQRSTUVWXYzAöAÜ_`abcdefghijklmnopqrstuvwxyzääü
 D/N !"#\$%&'()*+,-./0123456789:;<=>?@ABCDEFGHIJKLMNopQRSTUVWXYzÆØAÜ_`abcdefghijklmnopqrstuvwxyzæøäü
 ESP !"£\$%&'()*+,-./0123456789:;<=>?SABCDEFgHIJKLMNopQRSTUVWXYzIñ¿áé`abcdefghijklmnopqrstuvwxyzíñó

MULTIPASS PRINTING { USA !"#\$%&'()*+,-./0123456789:;<=>?@ABCDEFGHIJKLMNopQRSTUVWXYz[\]^_`abcdefghijklmnopqrstuvwxyz{|}~
 FRA !"£\$%&'()*+,-./0123456789:;<=>?aABCDEFGHIJKLMNopQRSTUVWXYz°ç§^_`abcdefghijklmnopqrstuvwxyzéùè`
 UK !"£\$%&'()*+,-./0123456789:;<=>@ABCDEFGHIJKLMNopQRSTUVWXYz[\]^_`abcdefghijklmnopqrstuvwxyz{|}~
 GER !"#\$%&'()*+,-./0123456789:;<=>?SABCDEFgHIJKLMNopQRSTUVWXYzAöÜ^_`abcdefghijklmnopqrstuvwxyzääüß
 ITL !"£\$%&'()*+,-./0123456789:;<=>?SABCDEFgHIJKLMNopQRSTUVWXYz°é|^_`abcdefghijklmnopqrstuvwxyzàèì
 S/F !"£\$%&'()*+,-./0123456789:;<=>?EABCDEFgHIJKLMNopQRSTUVWXYzAöAÜ_`abcdefghijklmnopqrstuvwxyzääü
 D/N !"#\$%&'()*+,-./0123456789:;<=>?@ABCDEFGHIJKLMNopQRSTUVWXYzÆØAÜ_`abcdefghijklmnopqrstuvwxyzæøäü
 ESP !"£\$%&'()*+,-./0123456789:;<=>?SABCDEFgHIJKLMNopQRSTUVWXYzIñ¿áé`abcdefghijklmnopqrstuvwxyzíñó

DIP SWITCH SETTINGS SW1 00010110 SW2 00011000 SW3 00010001 SW4 10001011

NOTE 1: 0 = CLOSED, 1 = OPEN
 NOTE 2: ORDER OF SWITCH DISPLAY IS: 87654321

Figure 3-1 Self-Test Printout

SECTION 4

OPERATOR MAINTENANCE

4.1 PREVENTIVE MAINTENANCE

Although there are no regularly scheduled operator preventive maintenance procedures, it is advisable to periodically inspect and clean the printer area immediately accessible under the top cover.

During paper loading or ribbon replacement, the printer should be inspected for a build-up of dried

ink, lint, or foreign material. If a build-up of material is evident, clean the area with a light bristle brush or lint free cloth.

Table 4-1 below lists the maintenance required on certain areas of the printer. The maintenance may be required more or less frequently, depending on the printer application and operating environment.

Table 4-1 Preventive Maintenance

ASSEMBLY	FREQUENCY	MAINTENANCE
Covers	As Required	Clean all the cover assemblies using a mild detergent and a lint-free cloth.
Internal Inspection	Each Ribbon Change	Remove the top cover and visually inspect interior of printer for loose wires, connectors, and hardware, chafing of cables, and worn or damaged parts.
Print Head Assembly	Each Ribbon Change	Using a lint-free cloth gently remove all dried ink from the front of the print head.
Print Head and Carriage	Each Ribbon Change	After removing ribbon, use a light bristle brush to carefully remove the dust and residue from the print head and carriage assembly.
Platen Assembly	As Required	Clean platen assembly using a mild detergent.

4.2 TROUBLESHOOTING GUIDE

The troubleshooting guide, Table 4-2 lists some malfunctions which may occur, the probable causes, and the remedies. If the printer remains

inoperative after performing the remedies indicated, the printer should be serviced by qualified service personnel.

Table 4-2 Troubleshooting Guide

TROUBLE	PROBABLE CAUSE	REMEDY
Printer completely inoperative.	AC power cord not connected. AC input fuse blown.	Connect AC cord to power source. Check if POWER indicator is lit. If indicator is not lit, replace AC input fuse.
Power On/Data Sent Printer does not print.	Input cable not connected. Printer not selected. Top cover opened.	Check that connectors at both ends of data input cable are properly connected. Press SELECT switch on the operators control panel. Close top cover to disable cover interlock switch.
Cut sheet form does not advance.	Not in cut sheet mode. Forms lever not in SHEET position.	Press CUT SHEET MODE switch on the operators control panel. Move forms lever to SHEET position.
Improper feeding of fanfold forms-skew.	Improper pin feed alignment of form.	Align forms evenly on pin feed tractors.
Ribbon does not feed properly.	Improperly loaded or twisted ribbon.	Check ribbon cassette replacement procedure.
No or erratic Print Head/ Carriage movement.	Forms lever in LOAD position. Dirty carriage guide bars.	Place forms lever in FORM or SHEET position. Clean guide bars using a soft lint free cloth.
Print too light.	Print head adjustment lever improperly adjusted. Worn or defective ribbon.	Adjust head adjustment lever in or out for optimum print quality. Replace ribbon cassette.

SECTION 5

REMOVAL/REPLACEMENT

5.1 GENERAL

This section details the operator removal/replacement procedures. The covers, print head assembly, and input fuse are all operator replaceable. For detailed removal/replacement procedures of all recommended spare parts refer to the Model 351 Technical Manual.

NOTE

Ensure the power cord is removed from the power outlet before performing any removal/replacement procedures.

5.2 REMOVAL COVER ASSEMBLIES

The following procedures detail the removal of the top, rear, and body covers. To remove the covers, refer to Figure 5-1 and perform the following:

TOP COVER

1. Remove the top cover by lifting the rear edge of the cover up and off the printer.

REAR COVER

1. Unsnap the top portion of the rear cover from the body cover.
2. Rotate the cover to the extreme rear (open) position.
3. Lift the rear cover up and off the printer.

BODY COVER

1. Remove the top and rear covers from the printer.
2. Remove the two Phillips head screws at the rear of printer mounting the body cover to the printer base.
3. Loosen the thumb screw mounting the front of the body cover to the printer base.
4. Lift the body cover up and off the printer.

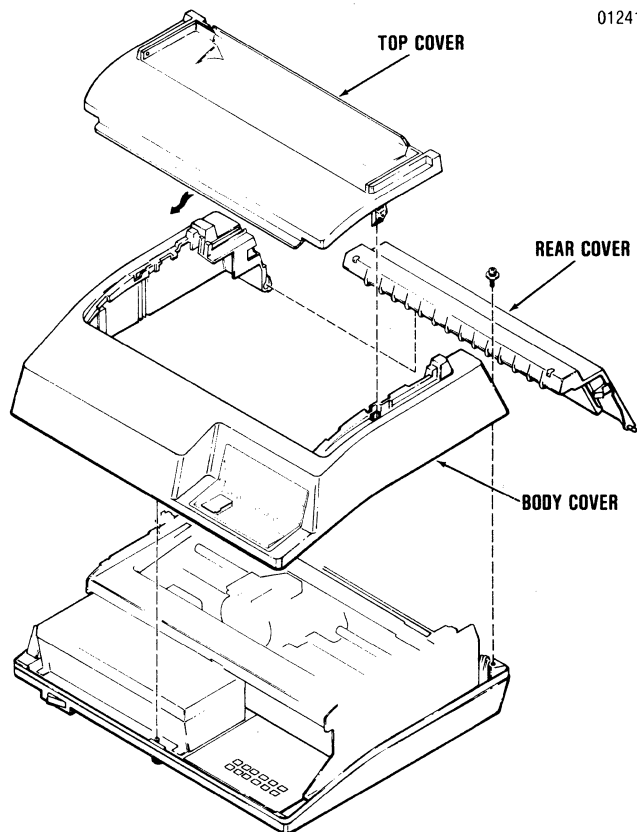

Figure 5-1 Removal Cover Assemblies

5.3 REMOVAL/REPLACEMENT PRINT HEAD ASSEMBLY

To remove and replace the print head assembly, refer to Figure 5-2 and perform the following steps:

1. Remove the top cover by lifting the rear edge of the cover up and off the printer.
2. Unsnap the top portion of the rear cover and place in the open position.
3. Move the forms lever to the "LOAD" position.
4. Lift the column scale to the up position.
5. Move the forms lever to "CUT SHEET" or "FAN FOLD" position.
6. Move the print head/carriage assembly to the middle of the printer.
7. Loosen the nylon thumbscrew on the carriage assembly.
8. Pull the head adjustment lever towards the front of the printer to its maximum position.
9. Remove the ribbon guide from the front of the print head by squeezing together the two tabs at the top of the ribbon guide and lifting upward.
10. Remove the print head fingerboard connector.
11. While pulling the print head towards the front of the printer, lift the head up and out of the printer.
12. Replace the print head by performing steps 8-11 in reverse order.
13. Tighten the nylon thumbscrew until the screw makes contact with the head heatsink. **DO NOT OVERTIGHTEN THE SCREW.**
14. Perform steps 1-6 in reverse order.

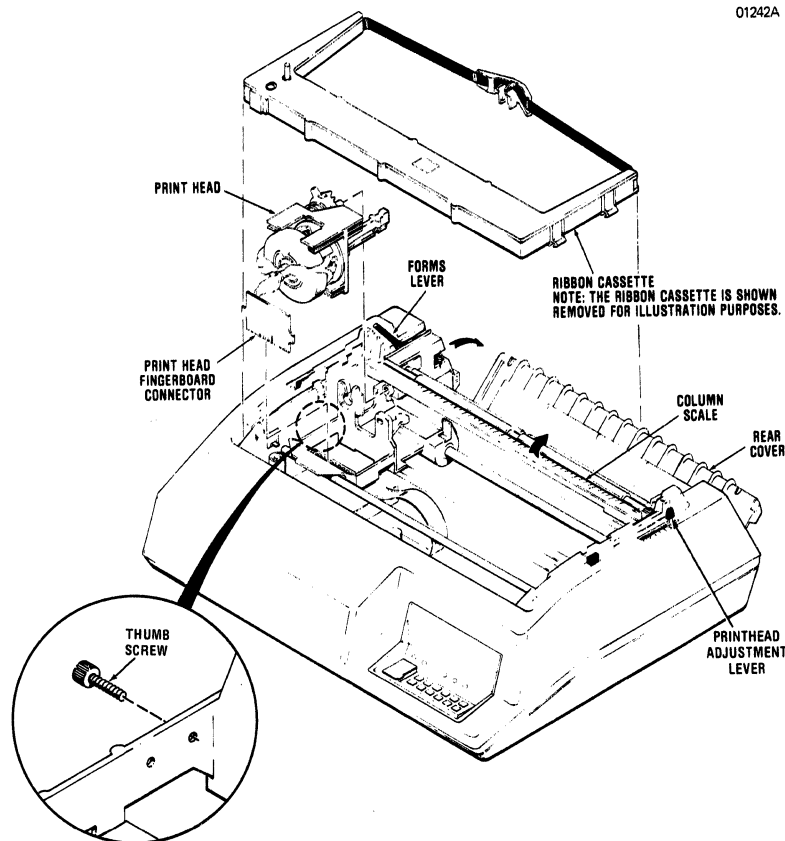

Figure 5-2 Removal Print Head Assembly

5.4 REMOVAL/REPLACEMENT INPUT FUSE

To remove and replace the input fuse, refer to Figure 5-3 and perform the following steps:

1. Locate the input fuse at the left rear of the printer.
2. Using a flat blade screwdriver rotate the fuse holder cap counterclockwise until loose, then remove the cap and defective fuse.
3. Install new fuse in the fuse holder and reinstall the cap by turning it clockwise with the screwdriver.

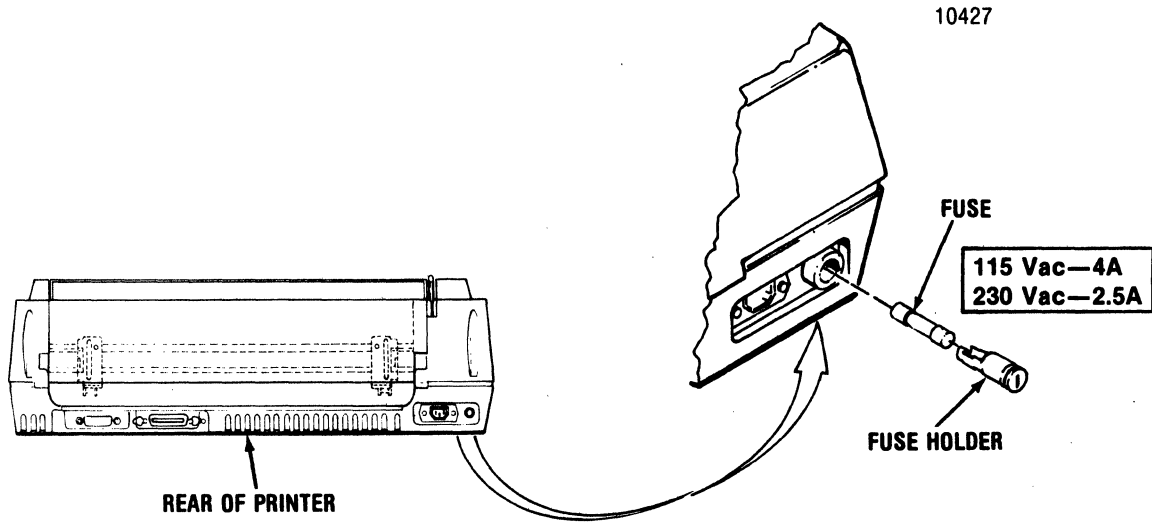

Figure 5-3 Removal Input Fuse

CONTENTS

Section 6	Installation
Section 7	Printer Features
Section 8	Interface Information
Section 9	Specifications

Installation, Interface and Specifications

1944

1944
1944
1944
1944

1944
1944

SECTION 6 INSTALLATION

6.1 GENERAL

This section contains information on installing and setting-up the printer. The Model 351 should be installed in an area that is free from excessive dust and dirt and is easily accessible from all sides.

6.2 PRINTER INSPECTION

After unpacking, visually inspect the printer for signs of damage received during shipment. Immediately notify the common carrier of any damage.

6.3 SITE CONSIDERATIONS

When selecting a site to install the printer the following should be taken into consideration.

PRINTER DIMENSIONS—Refer to Figure 6-1.

PRINTER INSTALLATION SPECIFICATIONS—Refer to the following printer specifications before installing the printer.

WEIGHT

Printer: 47 lbs.
Stand: 22.5 lbs.

HUMIDITY

Operating: 10% to 90% (Non-Condensing)
Storage: 10% to 95% (Non-Condensing)

TEMPERATURE

Operating: 50@ to 104@F (10@ to 40@C)
Storage: -40@ to 151@F (-40@ to 66@C)

ELECTRICAL

90 VAC to 128 VAC or 180 VAC to 256 VAC;
47 to 63 Hz

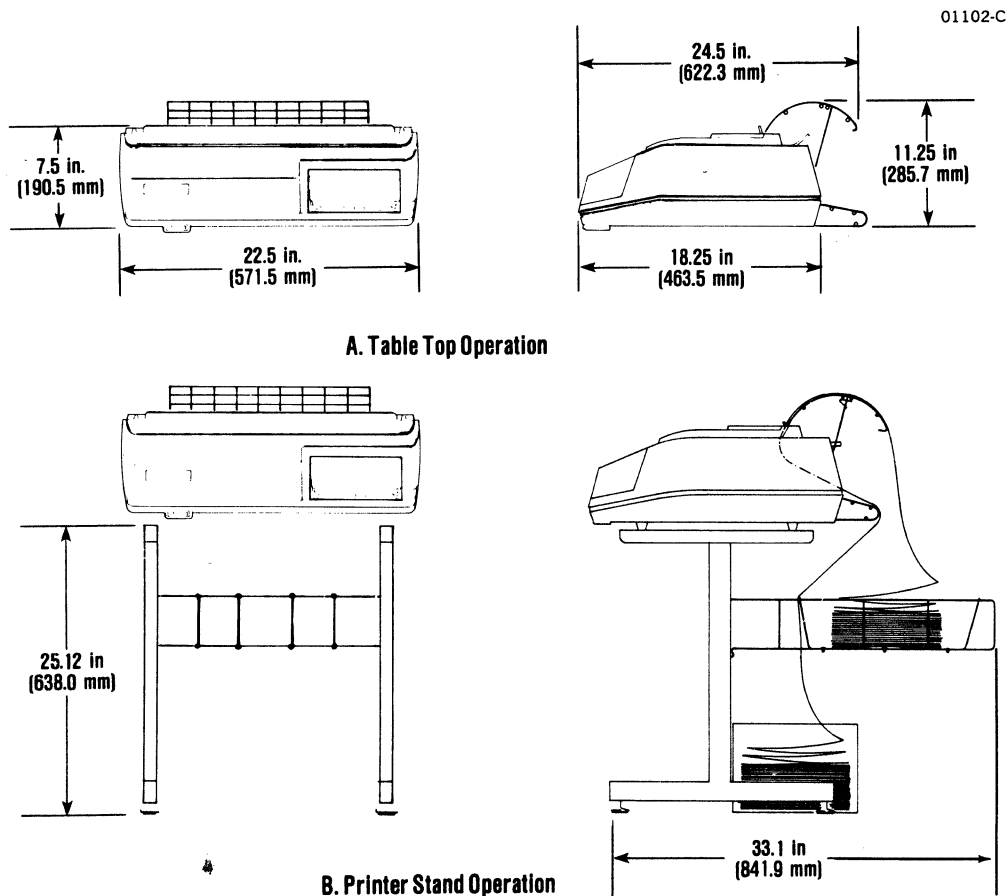

Figure 6-1 Printer Dimensions

6.4 PRINTER SET-UP

The following procedures detail the set-up of the printer prior to operation at the installation site. Refer to Figure 6-2 and 6-3 and perform the following steps.

NOTE

Refer to Figure 6-2 and 6-3 for steps 1 through 6.

1. Locate the paper rack inlet and, while facing the rear of the printer, install the rack into the two mounting holes on the left and right frames.
2. Locate the paper rack outlet assembly and remove the two nylon thumbnuts from the two mounting arms. Retain the thumbnuts.
3. Facing the rear of the printer, install the two end mounting tabs on the paper rack outlet assembly into the two mounting holes on top of the rear cover.
4. Install the two threaded mounting arms of the paper rack outlet assembly into the mounting holes in the middle of the rear cover.
5. Open the rear cover and install the two nylon thumbnuts onto the threaded portion of the mounting arms.
6. Close the rear cover.

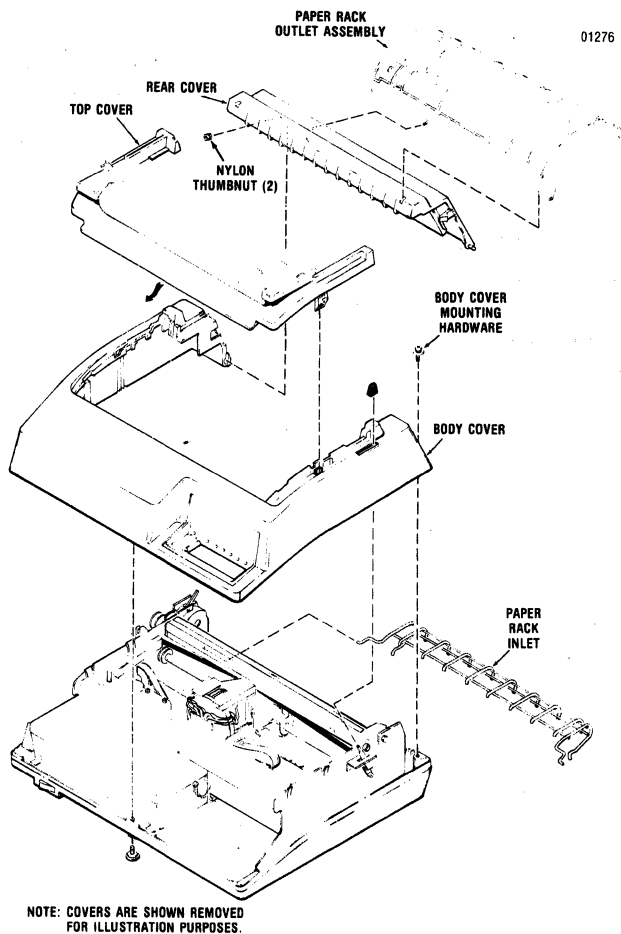

Figure 6-2 Installation Paper Rack Outlet and Paper Rack Inlet

7. Ensure the power switch is OFF and plug the printer into the appropriate power outlet.

NOTE

Always use a 3-wire grounded outlet.

8. Using the appropriate shielded data cable (parallel or serial input), connect the printer to the input device.

NOTE

The data cable should be terminated to chassis ground at either the printer connection or host connection. The illustration below shows the recommended terminating connection on the printer.

9. Install the form (fanfold or cut sheet) to be printed as described in Section 2, Paper Loading/Ribbon Replacement.

10. Check the settings of dip switches S1, S2, S3, and S4 per Section 7, to ensure the desired printer features are selected.

11. Set the **POWER** switch to the ON position.

12. Press the **SELECT** switch, lighting the **SELECT** indicator, to enable the printer to receive data.

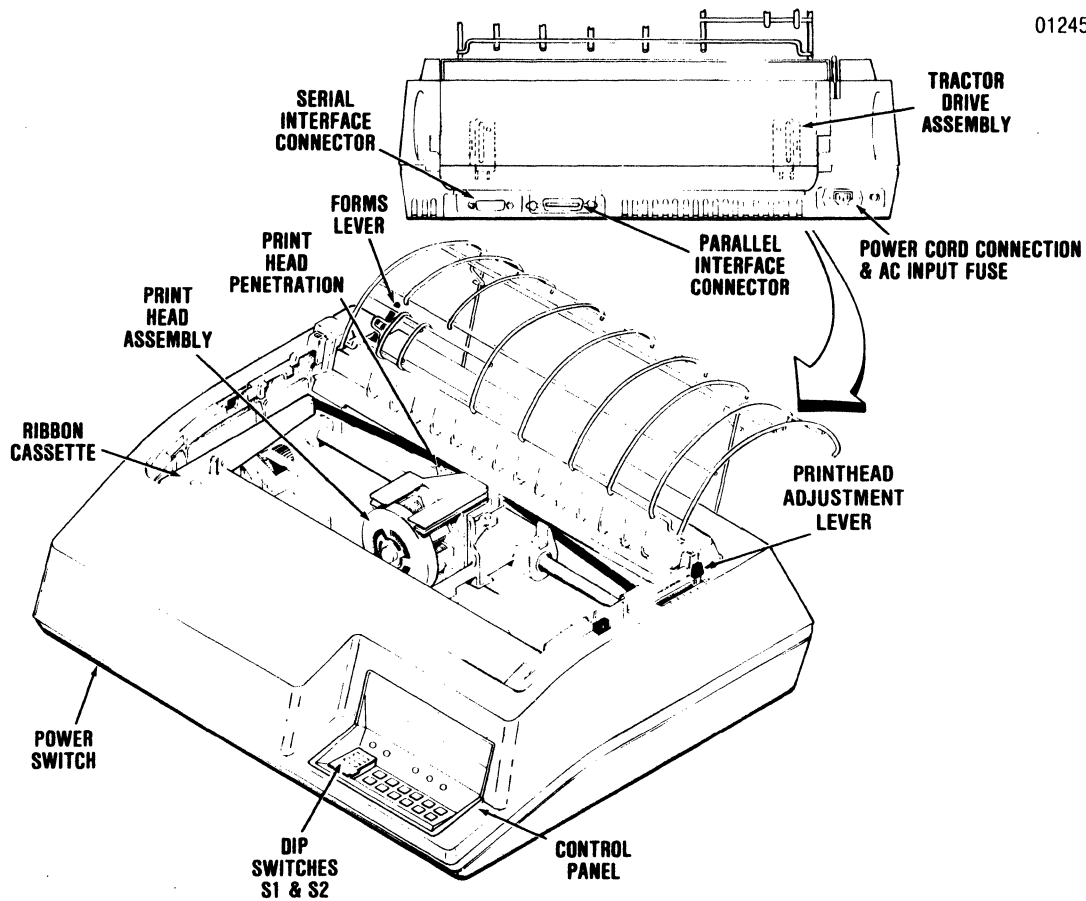

Figure 6-3 Printer Set-Up

SECTION 7

PRINTER FEATURES

7.1 PRINTER FEATURE SELECTION

The printer contains four DIP switches labelled S1, S2, S3, and S4. These switches are used to select printer features. DIP switches S1 and S2 are located on the control panel assembly. DIP switches S3 and S4 are located within the printer and are accessible only by removing the printer body cover (refer to Body Cover Removal in paragraph 7.7). The paragraphs in this section describe the settings of each DIP switch for the following list of features:

- Auto Line Feed
- Prime on Delete
- Prime on Select
- Form Length
- 6/8 Lines per Inch
- Baud Rate
- Self Test
- Country Character Set Selection
- Reverse Channel Polarity
- DTR (Data Terminal Ready) and Reverse Channel
- X-ON/X-OFF
- Parallel/Serial Input
- Page Mode Enable
- New Line Mode

NOTE

The switch settings are read only on power-up of the printer. To select a printer feature, set the switch to the desired position, power-down the printer, then power up the printer. The new printer feature is now selected.

7.2 PRINTER FEATURES DIP SWITCH S1

Dip switch S1, on the control panel, is used to select Auto Line Feed, Prime on Delete, Prime on Select, and Form Length. Refer to Figure 7-1 for the location of dip switch S1 and the table of switch positions for these features.

AUTO LINE FEED—If the Auto Line Feed feature is selected, a line feed is performed on receipt of a carriage return (CR) code or at the end of printing a line. If the CR code is the first character in the buffer, a line feed is not performed.

PRIME ON DELETE—When prime on delete is selected and a delete code is received, the line buffer is cleared and the print head is returned to the left margin.

PRIME ON SELECT—When this feature is selected and the printer is selected, the print head is returned to the left margin and the input buffer is cleared.

FORM LENGTH—Switch sections 1 through 5 of dip switch S1 are used to select the form length which may be settable from 0.5 inches to 15.5 inches as shown in the table in Figure 7-1. Form length is measured in the number of lines per form. Software changing of the vertical pitch will change the form length.

7.3 PRINTER FEATURES DIP SWITCH S2

Dip switch S2, on the control panel, is used to select the number of lines per inch (6/8 lpi), Baud rate, Self Test, and character set selection. Figure 7-2 shows the location of dip switch S2 on the printer control panel and includes a table that lists the switch positions for Baud rate and character set selection.

CHARACTER SET SELECTION—Switch sections 1, 2, and 3 of dip switch S2 are used to select the character set as determined by the binary value indicated for these switches in Figure 7-2. These three switch sections select one of eight possible countries (USA always included) for which substitute characters will be printed.

SELF-TEST—Dip switch (S2) section 4 overrides all other communications switches and places the system in self-test mode when set to open position. This test includes character set display and a list of the switch settings that are operative when the printer is selected.

BAUD RATE—Dip switch S2 sections 5, 6, and 7 are used to select printer Baud rate as determined by the binary values indicated for these switches in Figure 7-2.

6/8 LINES PER INCH—Dip switch S2 section 8 is used to set the vertical pitch (spacing between lines) at either 6 or 8 lines per inch. The height of the printer characters is not affected.

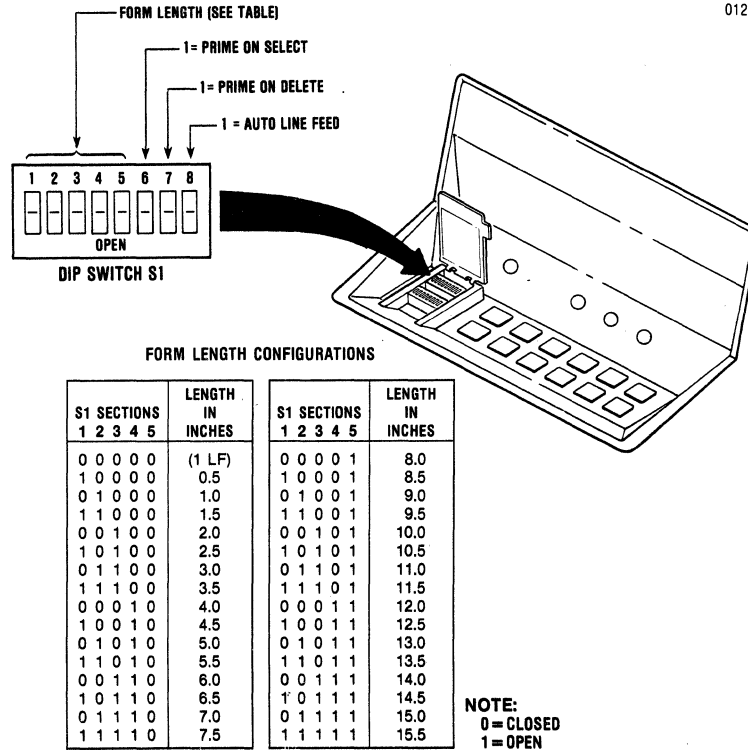

Figure 7-1 Printer Features Dip Switch S1

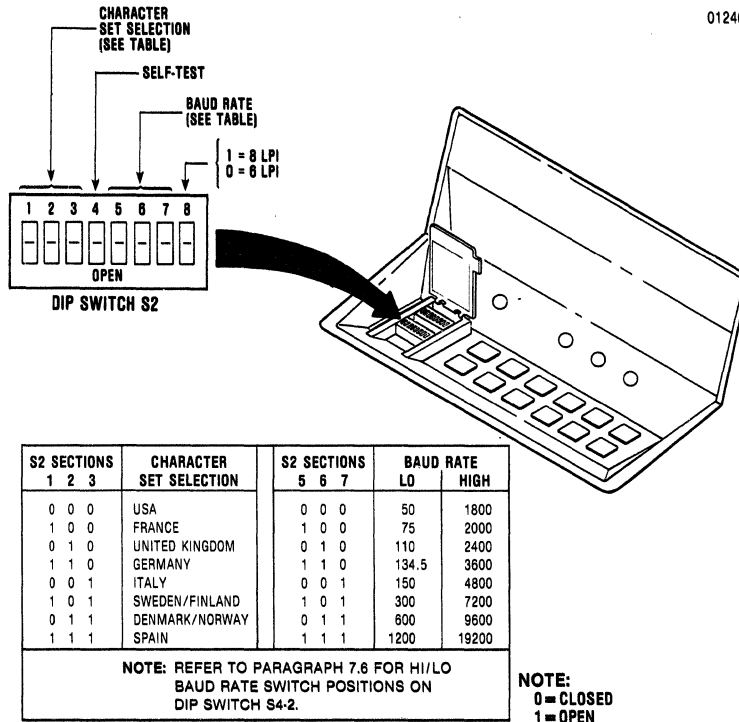

Figure 7-2 Printer Features Dip Switch S2

7.4 ACCESSING DIP SWITCHES S3 AND S4

DIP switches S3 and S4 are located inside the printer on the printed circuit board and are set by first removing the body cover. Figure 7-3 shows the location of the switches.

NOTE

The switch settings are read only on power-up of the printer. To select a printer feature, set the switch to the desired position, power-down the printer, then power up the printer. The new printer feature is now selected.

1. Remove the top cover from the printer.
2. Referring to paragraph 7.5 and 7.6, set the dip switches to the desired position using the tip of a ball point pen.

3. Once the switches are set, replace the top cover.

7.5 PRINTER FEATURES DIP SWITCH S3

Dip switch S3 is used to select: serial or parallel operation, page mode, reverse channel high or low for busy, reverse channel with or without DTR, parity or no parity, odd or even parity, X-ON/X-OFF, and new line mode. Figure 7-3 includes a table that identifies the switch positions for the printer features that can be obtained with dip switch S3.

PARALLEL/SERIAL—This switch is used to set either parallel or serial mode of data transfer.

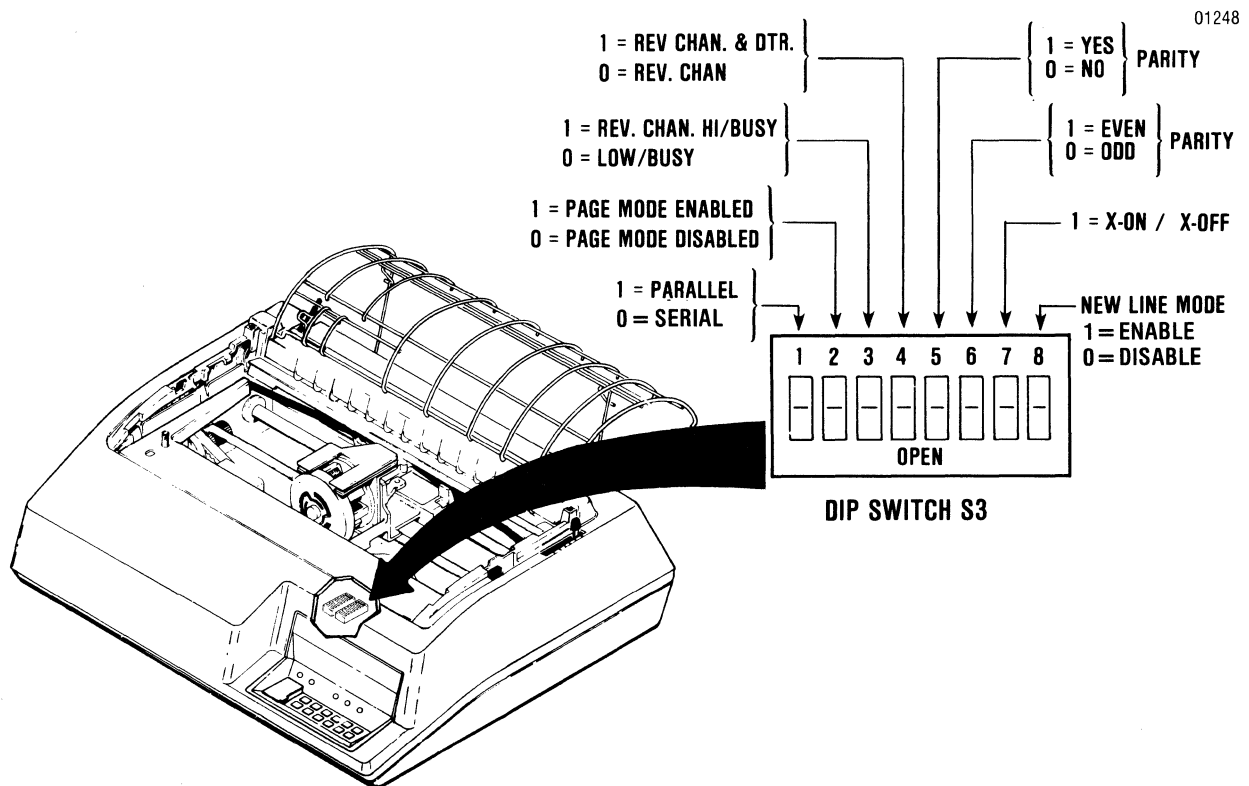

Figure 7-3 Printer Features Dip Switch S3

PAGE MODE (ENABLE/DISABLE)—This switch is used to determine if the control code (STX) will start the page mode or is acknowledged and ignored. In page mode, the printer will not print any of the data received until 2048 bytes of data have been received or an ETX control code is received.

REVERSE CHANNEL POLARITY (+ / -)—This switch is used to determine whether reverse channel or inverted reverse channel is to indicate busy.

REVERSE CHANNEL AND DTR—This switch is used to determine if busy is to be indicated by Reverse Channel or Reverse Channel and DTR.

PARITY—This switch is used to determine if a parity bit will be included to provide a check for accuracy. If a character is read as having the wrong parity, the @ sign will be substituted for that character to provide indication of the error.

ODD/EVEN PARITY—When parity is included, this switch is used to determine if the parity will be odd or even.

X-ON/X-OFF—This switch is used to select X-ON/X-OFF transmission as an alternate method of indicating busy/not busy.

NEW LINE MODE (ENABLE/DISABLE)—This switch is used to enable or disable new line mode. If new line mode is enabled, the characters Line

Feed (LF), Vertical Tab (VT), or Form Feed (FF) each cause the data following it to be printed at the left margin.

EXAMPLE:

DATA: A (LF) B (LF) C (VT) D (FF) E (CR) X (CR)

NEW LINE MODE:

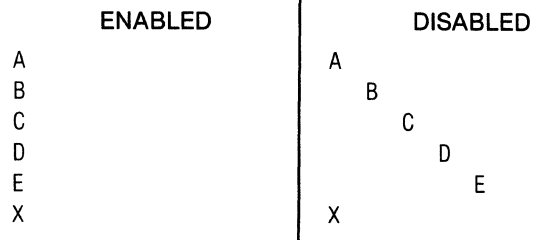

DTR = SELECT—DTR = SELECT (DTR line follows SELECT) is a derived feature that is accomplished by setting three of the switch sections on dip switch S3 as follows:

SW. SECT.	SETTING	FUNCTION
3	CLOSED (0)	LOW/BUSY
4	OPEN (1)	REV. CH. + DTR
7	CLOSED (0)	NO X-ON/X-OFF

7.6 PRINTER FEATURES DIP SWITCH S4

DATA LINK—Section 1 of dip switch S4: refer to Appendix A for technical information and usage of this switch.

01249

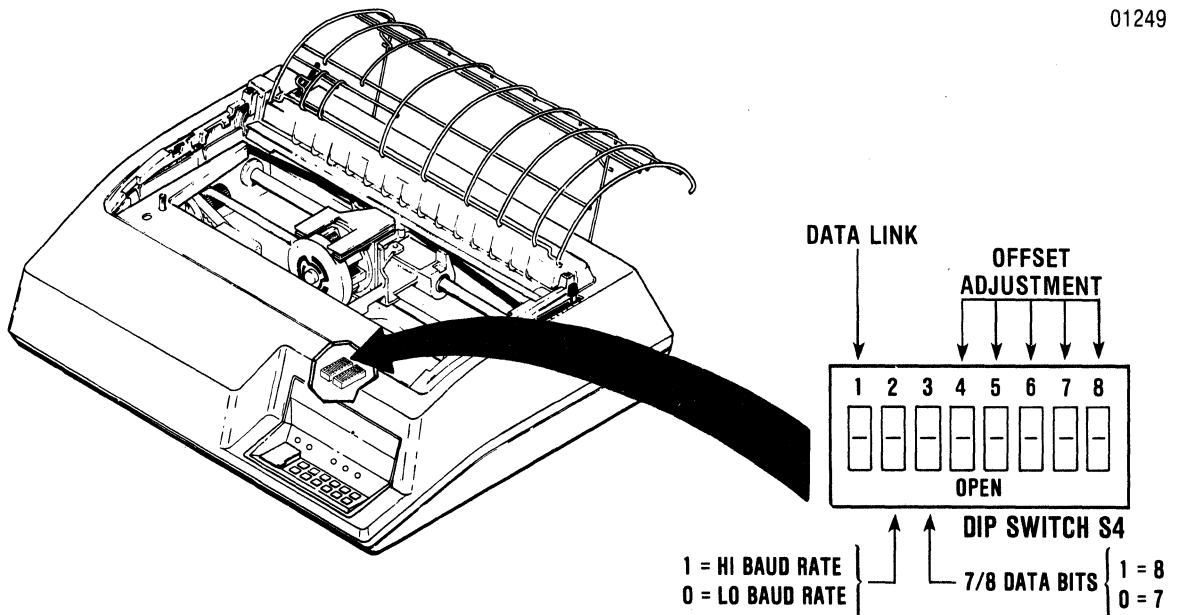

Figure 7-4 Printer Features Dip Switch S4

HI/LO BAUD RATE—Section 2 of dip switch S4 is used to select either the upper or lower baud rate ranges that are available via the various positions of sections 5, 6 and 7 of dip switch S2. Refer to the table shown in Figure 7-4 for the required switch positions for the desired baud rate.

7/8 DATA BITS—Section 3 of dip switch S4 is used to set the number of data bits in the word length. The closed position will permit 7 bit operation, while the open position will permit 8 bits.

OFFSET ADJUSTMENT—Sections 4 (LSB), 5, 6 and 7 (MSB) of dip switch S4 provide a fine horizontal adjustment for aligning forward to reverse printing. Refer to the Model 351 Technical Manual, Section

4, paragraph 4.8, for the setting procedures of these switch sections.

7.7 DATA STROBE SWITCH

When shipped, the Model 351 printer is normally set to accept noninverted data strobe signals from the host system.

If the host system supplies inverted data strobe signals to the printer, call your Centronics Field Service representative for this configuration change.

7.8 FACTORY SETTINGS

The printer is shipped from Centronics with the four DIP switches set as indicated in Table 7-1.

Table 7-1 Factory Configuration of DIP Switches

DIP SWITCH NO. 1			DIP SWITCH NO. 2		
1	CLOSED	} ELEVEN INCHES	1	CLOSED	} USA CHAR. SET
2	OPEN		2	CLOSED	
3	OPEN		3	CLOSED	
4	CLOSED		4	CLOSED	} SELF-TEST*
5	OPEN		5	CLOSED	
6	CLOSED	PRIME ON SELECT	6	OPEN	} 9600 BAUD
7	CLOSED	PRIME ON DELETE	7	OPEN	
8	CLOSED	AUTO LINE FEED	8	CLOSED	6 LPI
DIP SWITCH NO. 3			DIP SWITCH NO. 4		
1	OPEN	PARALLEL INPUT	1	-----	DATA LINK*
2	CLOSED	PAGE MODE	2	OPEN	HI BAUD RATE
3	OPEN	REV. CH. HI/BUSY	3	CLOSED	7 DATA BITS
4	OPEN	REV. CH. & DTR	4	#	} WINDAGE ADJ.
5	CLOSED	NO PARITY	5	#	
6	OPEN	ODD PARITY	6	#	
7	OPEN	X-ON/X-OFF	7	#	
8	CLOSED	NEW LINE MODE	8	#	
<p>NOTE: CLOSED = 0 = LOW = DISABLED OPEN = 1 = HIGH = ENABLED * = AS REQUIRED # = THESE SETTINGS WILL VARY BETWEEN PRINTERS. SEE TEXT FOR ADJUSTMENT REFERENCE.</p>					

SECTION 8

INTERFACE INFORMATION

8.1 GENERAL INFORMATION

The printer is connected to the input device, via the input data cable, for either parallel or serial operation. In the right rear of the printer the pcb provides a parallel interface connection via an Amphenol 57 series 36-pin connector and a serial interface connection via an EIA-RS232C, 25 pin connector. Four unused pins in the serial interface connector are used for the optional current loop connection. The following paragraphs describe the parallel and serial interfaces in detail.

8.2 PARALLEL INTERFACE CONNECTION

The pin-outs of the 36-pin parallel interface connector are listed in Table 8-1. A description of the external and printer generated parallel signals follow the table.

EXTERNAL GENERATED SIGNAL DESCRIPTION—

The following signals are generated by the input device.

DATA STROBE—Data strobe is a negative or positive going pulse used to transfer the incoming parallel data into the printer logic. The pulse duration of the signal must be a minimum of 1.0 microsecond. The leading and trailing edges of data strobe and the input data must be as shown in Figure 8-1.

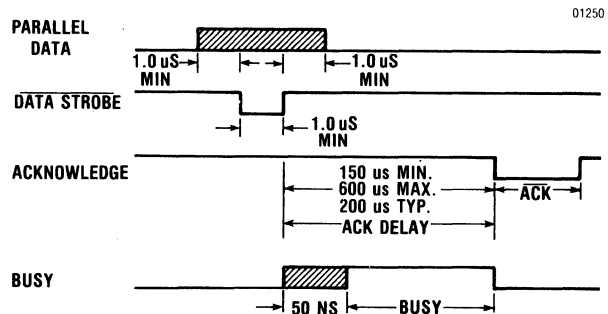

Figure 8-1 Parallel Interface Timing Diagram

Table 8-1 Parallel Interface Connector Pin-Outs

PIN	SIGNAL	PIN	SIGNAL
1	DATA STROBE	19	Twisted Pair Ground
2	Data Bit 1	20	Twisted Pair Ground
3	Data Bit 2	21	Twisted Pair Ground
4	Data Bit 3	22	Twisted Pair Ground
5	Data Bit 4	23	Twisted Pair Ground
6	Data Bit 5	24	Twisted Pair Ground
7	Data Bit 6	25	Twisted Pair Ground
8	Data Bit 7	26	Twisted Pair Ground
9	Data Bit 8	27	Twisted Pair Ground
10	ACKNOWLEDGE	28	Twisted Pair Ground
11	BUSY	29	Twisted Pair Ground
12	PAPER OUT	30	INPUT PRIME RETURN
13	SELECT	31	INPUT PRIME
14	GROUND	32	FAULT
15	Not Used	33	GROUND
16	GROUND	34	Not Used
17	CHASSIS GROUND	35	Not Used
18	+5V	36	Not Used

DATA BITS 1-8—Data bits 1 through 8 contain the ASCII character and control code information. The logic level of each data line must be settled at least 1.0 microsecond before the leading edge of the data strobe pulse and remain at its logic level until at least 1.0 microsecond after the trailing edge of the data strobe pulse.

INPUT PRIME—Input prime is an active low signal which causes the print head to return to the left margin and resets the printer logic on the trailing edge of the signal.

PRINTER GENERATED SIGNAL DESCRIPTION—The following signals are generated by the printer.

ACKNOWLEDGE—Acknowledge is an active low signal used to verify the transfer of incoming data from the input device to printer logic or to signify the end of a functional operation. Once a code is sent to the printer, an acknowledge pulse must be received before a new code can be sent.

BUSY—Busy is an active high signal which inhibits data transmission from the input device. Busy goes active on the trailing edge of **DATA STROBE** or when either the paper empty or fault status line is active high.

PAPER EMPTY—Paper empty is a positive-going signal that indicates the printer is out of paper.

SELECT—An active high select signal indicates either the **SELECT** switch has been pressed or a **SELECT** code has been received and that the printer is in a ready condition.

FAULT—Fault is an active low signal that indicates paper empty, deselect or a “not ready” state.

8.3 SERIAL INTERFACE CONNECTION

The pin-outs of the 25-pin serial interface connector are listed in Table 8-2. A description of the data set and printer generated signals follow the table.

DATA SET GENERATED SIGNAL DESCRIPTION—The following signals are generated by the data set.

NOTE

A +V or Mark condition indicates a voltage greater than +3 volts. A -V or Space condition indicates a voltage less than -3 volts.

Signals **CLEAR TO SEND**, **DATA SET READY** and **CARRIER DETECT** will be interpreted as a logical 1 if they are not connected to the data set.

Table 8-2 Serial Interface Connector Pin-Outs

PIN	EIA SIGNAL NAME	SIGNAL
1	AA	Protective Ground
2	BA	Transmitted Data
3	BB	Received Data
4	CA	Request to Send
5	CB	Clear to Send
6	CC	Data Set Ready
7	AB	Signal Ground
8	CF	Carrier Detect
11	SBA	Reverse Channel
20	CD	Data Terminal Ready
12	----	Host Receive Current Loop +
13	----	Host Receive Current Loop -
14	----	Printer Transmit Status +
15	----	Printer Transmit Status -

RECEIVED DATA—Data source to the printer.

CLEAR TO SEND—A +V will enable X-ON/X-OFF or printer status to be transmitted. A -V will disable the transmitter.

DATA SET READY—A +V will allow transmitted data to be accepted by the printer. A -V will not allow data to be accepted.

CARRIER DETECT—A +V will allow transmitted data to be accepted by the printer. A -V will not allow data to be accepted.

PRINTER GENERATED SIGNAL DESCRIPTION—The following signals are generated by the printer.

TRANSMITTED DATA—Used to indicate the buffer status when in the X-ON/X-OFF mode.

REQUEST TO SEND—This line is +V when in the X-ON/X-OFF mode. When not, it is -V.

REVERSE CHANNEL—Used for transmitting the printer/buffer status when in the reverse channel mode. The line is normally in a -V condition. When the buffer is full, this line goes to a +V condition until the printer is able to receive data again. This may be inverted by changing the setting of the reverse channel polarity dip switch. The line is held at buffer empty polarity (-V) when in the X-ON/X-OFF.

DATA TERMINAL READY—This line is held at +V when not used for the status report line. When it is used for status, then it follows Reverse Channel.

SECTION 9

SPECIFICATIONS

9.1 MODEL 351 SPECIFICATIONS

SERIAL INPUT

Interface	RS-232C
Data Format	1 START bit, 7 or 8 DATA bits, 1 possible PARITY bit, and 1 or more STOP bits
Input Code	96 character ASCII.
Buffer	2K character buffer.

PARALLEL DATA

Data Format	7 bit ASCII parallel.
Input Code	96 character ASCII.
Buffer	One line character buffer.
Input Gating	Data Strobe is gated with Acknowledge of previous character.
Input Speed	5000 cps (typical)

PRINTING

Printing Method	Impact, dot matrix, bidirectional, logic seeking.
Dot Matrix	7 dots wide by 9 dots high; 9th wire underline. (DP); N dots wide by 9 dots high (proportional).
Print Speed	200 characters per second. (DP) 100 characters per second (proportional).
Country Character Sets	U.S.A., Great Britain, Sweden/Finland, Norway/Denmark, Germany, Italy, France and Spain.
Horizontal Pitch	Programmable for 5, 6, 8.25, 10, 12, and 16.5 characters per inch, multi-pass, and proportional print.

Maximum Line Length

(varies with horizontal pitch)

5 cpi	66 columns
6 cpi	79 columns
8.25 cpi	109 columns
10 cpi	132 columns
12 cpi	158 columns
16.5 cpi	218 columns

PAPER HANDLING

Vertical Pitch	6/8 lines per inch.
Single Line Feed Time	30 millisecs.
Vertical Slew Speed	6 ips (152.4 mm/s for line feeds (30 millisecs/line); 8 ips (203.2 mm/s) for form feeds (20 millisecs/line).
Forms Length	1 to 192 lines.
Paper Movement	Bidirectional

9.1 Model 351 SPECIFICATIONS (cont.)

PHYSICAL/ENVIRONMENTAL/ELECTRICAL

Height	7.5 inches (190.5 mm)
Depth	18.25 inches (463.5 mm)
Width	22.5 inches (571.5 mm)
Weight	46 lbs. (22 kg)
Temperature	Operating: 50° to 104°F (10° to 40° C) Storage: -40° to 151°F (-40° to 66° C)
Humidity	Operating: 10% to 90% (No condensation) Storage: 10% to 95% (No condensation)
Power	
Switching Power Supply	90 VAC to 128 VAC or 180 VAC to 256 VAC 47 to 63 Hz
Input current	4A max. at 110 VAC 2A max. at 220 VAC

PAPER REQUIREMENTS

FANFOLD FORMS

Forms Construction—Forms may be glued or crimped. When gluing, the form thickness should not exceed .0204 in. (0.52 mm). When fastened with crimps they must be spaced a minimum of 2 in. (508 mm) along both edges of the forms. Crimps must not come within 0.5 in. (12.7 mm) of the fanfold. Metal staples cannot be used.

Sprocket Holes—The forms must have sprocket holes punched along both margins 0.25 ± 0.03 in. (6.4 ± 0.7 mm) from the paper edge to the hole center lines. The distance between hole center lines must be 0.5 ± 0.005 in. (12.7 ± 0.05 mm) non-accumulative in any 5 inch (127 mm) length and the diameter of the holes must be 0.156 ± 0.005 in. (4.0 ± 0.1 mm). The distance across the sheets between sprocket hole center lines must be uniform within 0.015 in. (0.381 mm).

Size and Weight

Length: 3.0 to 15.5 in. (7.6 to 39.4 cm)

Width: 3.0 to 15.0 in. (7.6 to 38.1 cm)

Thickness:

Single Part—15 lb. paper minimum

Multi-Part—Up to six part with carbon, 0.0204 in. (.52 mm) maximum.

Weight:

Single Part—15-20 lb. bond (56 g/m² to 75 g/m²)

Multi-Part—

Ply	Paper	Carbon
2	15 lb (56 g/m ²) bond	#7 (16.5 g/m ²) tissue
3	15 lb (56 g/m ²) bond 12 lb (45 g/m ²) bond	#7 (16.5 g/m ²) tissue
4-6	12 lb (45 g/m ²) except last copy 15 lb (56 g/m ²)	#7 (16.5 g/m ²) tissue

CUT SHEET FORMS

Forms Construction

- Multi-part forms may be glued on the top or bottom.
- Stapled forms may not be used.
- Split forms with each side containing a different thickness or number of sheets are not recommended.
- On multi-part forms, use 12 lb (45 g/m²) as first copies with heaviest copy last.
- On multi-part forms over four parts, use a 5 lb (12 g/m²) carbon tissue.

Size and Weight

Length: 3.0 to 15.5 in. (7.6 to 39.4 cm)

Width: 4.0 to 12.0 in. (10.1 to 30.5 cm)

Thickness:

Single Part—20 lb paper (70 g/m²) minimum

Multi-Part—Up to six part with carbon, 0.0204 in. (0.52 mm) maximum as follows:

Ply	Paper	Carbon
2	15 lb (56 g/m ²) bond	#7 (16.5 g/m ²) tissue
3	15 lb (56 g/m ²) bond 12 lb (45 g/m ²) bond	#7 (16.5 g/m ²) tissue
4-6	12 lb (45 g/m ²) except last copy 15 lb (56 g/m ²)	#7 (16.5 g/m ²) tissue

Recommendations for Improved Cut Sheet Forms

Handling

- Use a 20 lb (75 g/m²) bond for single part forms.
- Glued forms will improve multi-part forms handling.
- For forms having wide and narrow copies in the same form, the top copy should always be the fullest width.

CONTENTS

Section 10	Programming Information
Section 11	Print Generation

Programming Information

SECTION 10

PROGRAMMING INFORMATION

10.1 GENERAL PROGRAMMING INFORMATION

The Model 351 printer accepts ANSI compatible control codes and escape sequences. Using the control codes and escape sequences described in this section, the programmer can program the printer for the following features:

- Page Mode
- Primary Character Set Selection
- Alternate Character Set Selection
- Country Set Selection
- Horizontal Pitch
- Vertical Pitch
- Form Length

- Horizontal Tabs
- Vertical Tabs
- Subscript/Superscript
- Underline
- Expanded Print
- Top/Bottom Margins
- Variable Spacing
- Graphics

10.2 CONTROL CODES

Control codes are sent to the printer along with character codes via the input data lines. These codes are interpreted as instructions by the printer and initiate a specific function as listed in Table 10-1. The following paragraphs describe the ANSI control codes used in the Model 351 printer.

Table 10-1 ANSI Control Codes

MNEMONIC	DECIMAL	OCTAL	HEXA- DECIMAL	FUNCTION
STX	2	002	02	Page Mode start
ETX	3	003	03	Page Mode end
BEL	7	007	07	Audio Alarm
HT	9	011	09	Print at next sequential horizontal tab
LF	10	012	0A	One line feed forward
VT	11	013	0B	Paper motion to next vertical tab location
FF	12	014	0C	Paper motion to next top of form location
CR	13	015	0D	Carriage Return
SO	14	016	0E	Alternate character set
SI	15	017	0F	Primary character set
DLE ENQ	16 5	020 005	10 05	Serial status
DCI	17	021	11	Select printer command
DC3	19	023	13	Deselect printer command
ESC	27	033	1B	Escape sequence start
DEL	127	177	7F	Clears line buffer if in PRIME ON DELETE mode

PAGE MODE START, END (STX, ETX)—On receipt of an STX code with the page mode enabled, the printer enters into page mode. In the page mode, the printer is able to receive up to 2,048 characters, including control codes, without going busy. Printing is initiated on receipt of an ETX code or “buffer full”. The page mode is used for graphics data or a high speed page dump.

NOTE

The page mode is enabled only in the parallel mode of operation.

BEL—Receipt of a BEL code while the printer is selected causes the speaker to generate an audio tone for approximately one second.

HORIZONTAL TAB (HT)—If the printer is selected and horizontal tabs are set, receipt of an HT code causes printing to continue at the next sequential horizontal tab location. If no horizontal tabs are set, or there are no more tabs set on the line being printed, the HT code is changed to a space. The HT code is neither acknowledged nor processed while the printer is deselected.

LINE FEED (LF)—If the printer is on line, receipt of an LF code will cause the following action. A line feed preceded by text will cause the printer to print the data, ignore the auto line feed option, and perform a line feed.

VERTICAL TAB (VT)—If the printer is selected, receipt of a VT code causes the paper to advance to the next sequential vertical tab location. If no vertical tabs are set, the printer performs a form feed. The VT code is neither acknowledged nor processed while the printer is deselected.

FORM FEED (FF)—If the printer is selected, receipt of an FF code causes the paper to advance to the next sequential top-of-form location.

CARRIAGE RETURN (CR)—If the printer is selected and printable characters have been received, receipt of a CR code causes immediate printing. Data is accepted by the printer until a CR code or a full buffer of printable characters is received. In either case, the printer automatically prints the received characters. When printing is completed, the printer performs an auto line feed, if enabled. If the CR code is the first character in the buffer,

the code is acknowledged and ignored. A CR code is not acknowledged while the printer is deselected.

ALTERNATE CHARACTER SET (SO)—Receipt of an SO code will call up a designated alternate character set.

PRIMARY CHARACTER SET (SI)—Receipt of an SI code will return the primary character set and replace the designated alternate character set.

SERIAL STATUS (DEL ENQ)—In the serial mode, the sequence DLE ENQ requests printer status. The printer responds by sending DLE status, as defined below.

SERIAL STATUS

BIT	STATE	STATUS
0	High (1)	Paper Out
1	High (1)	Deselected
2	High (1)	Buffer Full
3	High (1)	Parity Error Received Since Last Printer Status

SELECT (DC1)—Receipt of a select code selects the printer independently of the control panel. If PRIME ON SELECT is enabled, the input line buffer is cleared and the print head is moved to the left margin.

DESELECT (DC3)—Receipt of a deselect code deselects the printer independently of the control panel and moves the print head to the left margin.

ESC—Receipt of an ESC code initiates an escape sequence. Additional information on escape sequences is described in paragraph 10.3.

DEL—Receipt of a DEL code will clear the line buffer if PRIME ON DELETE mode is enabled.

10.3 ESCAPE SEQUENCES

The Model 351 accepts and interprets ANSI escape sequences. In the escape sequences which follow, the escape character (octal 033) is designated as ESC. The second character in the sequence, if not a terminating character, may be a “[” (octal 133), “(” (octal 050), “)” (octal 051), or “%” (octal 045) depending on the function of the sequence. Numeric parameters are designated as n, n₁, n₂...etc. The graphic characters in the

escape sequences shown are from the US ASCII character set illustrated in Figure 10-1. The characters are spaced apart for clarity only. The space character (octal 040) never appears in an escape sequence.

A numeric parameter is a sequence of ASCII decimal digits (octal 060 through 071). The parameter is interpreted as an unsigned decimal integer, with the most significant digit transmitted first. Leading zeros are allowed, but not necessary. Skipped or unspecified parameters have a value of zero; extra parameters are ignored. Invalid terminators cause the sequence to be ignored. Up to 16 parameters may be inputted with a “;” (octal 073) between each parameter.

NOTE

Escape sequences must not be sent during an INPUT PRIME. Centronics reserves this sequence for in-house testing.

COUNTRY SET SELECTION—The Model 351 is capable of printing character sets of eight countries. If more than one country set selection is made for the printing of a line, only the last selection will be printed; all prior selections will be ignored. The escape sequences to select the country character sets are as follows:

ESCAPE SEQUENCE	FUNCTION/COMMENT
ESC (A	(101) Select Great Britain Character Set
ESC (B	(102) Select USA Character Set
ESC (2	(062) Select Sweden/Finland Character Set
ESC (3	(063) Select Norway/Denmark Character Set
ESC (K	(113) Select Germany Character Set
ESC (1	(061) Select Italy Character Set
ESC (R	(122) Select France Character Set
ESC (4	(064) Select Spain Character Set

HORIZONTAL TABS—There are a maximum of 16 horizontal tab stops. These are associated with specific character positions (columns). Thus, changing the horizontal pitch will change the physical location of the tabs.

ESCAPE SEQUENCE	FUNCTION/COMMENT
ESC H	(110) Set horizontal tab stop at current column.
ESC [g	(147) Clear horizontal tab stop at current column.
ESC [0g	Clear horizontal tab stop at current column.
ESC [2g	Clear all horizontal tab stops.
ESC [3g	Clear all horizontal tab stops.
ESC [nu	(165) Set horizontal tab stop at column n.
ESC [n ₁ ; n ₂ ...n _x u	Set horizontal tab stops at columns n ₁ , n ₂ ...n _x (x ≤ 16).

HORIZONTAL PITCH—Horizontal pitch determines the width of printed characters as well as their spacing. The horizontal pitch may be changed at any time within a line. The following escape sequences set horizontal pitch.

ESCAPE SEQUENCE	FUNCTION/COMMENT
ESC [w	(167) Select 10 cpi Horizontal Pitch
ESC [1 w	Select 10 cpi Horizontal Pitch
ESC [2 w	Select 12 cpi Horizontal Pitch
ESC [4 w	Select 16.5 cpi Horizontal Pitch
ESC [5 w	Select 5 cpi Horizontal Pitch
ESC [6 w	Select 6 cpi Horizontal Pitch
ESC [8 w	Select 8.25 cpi Horizontal Pitch

VERTICAL PITCH—Vertical pitch determines the spacing between lines, not the height of printed characters. Changing vertical pitch also clears vertical margins. The following escape sequences set vertical pitch. Changing vertical pitch clears margins.

ESCAPE SEQUENCE	FUNCTION/COMMENT
ESC [z	(172) Select 6 LPI Vertical Pitch
ESC [1 z	Select 6 LPI Vertical Pitch
ESC [2 z	Select 8 LPI Vertical Pitch

FORM LENGTH—Form length is defined in lines, not physical units. Therefore, changing vertical pitch will alter the physical form length. Forms may be from 1 to 192 lines in length. Changing form length clears vertical margins and defines the current line as line one.

ESCAPE SEQUENCE	FUNCTION/COMMENT
ESC [n t	(164) Set form length to n lines Set top margin to line 1 Set bottom margin to line n Set current line to line 1

Example:
ESC [66t—Sets the form length to 66 lines.

VERTICAL MARGINS—Printing is permitted only on lines within the inclusive top and bottom margins. When form length is changed, these margins are cleared; that is, the top margin is set to line one and the bottom margin is set to the form length. The following must be true to successfully set new vertical margins:

$$1 \leq \text{top margin} \leq \text{bottom margin} \leq \text{form length.}$$

If it is ever the case that: current line is less than the top margin or current line is greater than the bottom margin, the current line is set to the top margin. For example, a line feed performed at the bottom margin will execute a form feed.

ESCAPE SEQUENCE	FUNCTION/COMMENT
ESC [n r	(162) Set top margin to line n.
ESC [; n r	Set bottom margin to line n.
ESC [n ₁ ; n ₂ r	Set top margin to line n ₁ , and set bottom margin to line n ₂ .

Example:
ESC [1r—sets top margin to line 1.
ESC [; 66r—sets bottom margin to line 66.

The following escape sequence can be sent at one time to set both top and bottom margins.

ESC [1; 66r—sets the top margin to line 1 and the bottom margin to line 66.

VERTICAL TABS—The printer has 16 vertical tab stops. Vertical tab stops are associated with specific line numbers, not physical positions on the paper. Thus, changing vertical pitch changes the printing position of vertical tabs. The following escape sequences set or clear vertical tab stops.

ESCAPE SEQUENCE	FUNCTION/COMMENT
ESC J	(112) Select vert. tab stop at current line.

ESC [1 g	(147) Clear vert. tab stop at current line.
ESC [4 g	Clear all vert. tab stops.
ESC [n v	(166) Set vert. tab stop at line n.
ESC [n1; n2...nx v	Set vert. tab stop at line n1, n2,...nx (x = 16).

Example:
ESC [4 g—Clears all vertical tabs.

ESC [6; 16; 26; 36v—Sets vertical tabs at lines 6, 16, 26, and 36.

REVERSE LINE FEEDS—The printer accepts reverse line feed commands using the escape sequence below in the cut sheet mode only with reverse line feeds, it is possible to move paper out of the rollers.

ESCAPE SEQUENCE	FUNCTION/COMMENT
ESC [n T	(124) Move n reverse line feeds.

Example: ESC [6 T—Moves 6 reverse line feeds.

NOTE

Reverse line feeds are not allowed in fanfold mode of operation.

SUBSCRIPT/SUPERSCRIPT—The printer accepts subscript and superscript commands. The paper movement doesn't necessarily coincide with a half line feed, but is only used to offset by a partial line. If the same command is received more than once, all but the first is ignored. If a standard paper motion command is received while subscript or superscript is active, the print head moves to the base of the next line feed position.

ESCAPE SEQUENCE	FUNCTION/COMMENT
ESC K	(113) Set subscript on or superscript off.
ESC L	(114) Set superscript on or subscript off.

UNDERLINE—The printer accepts start and stop underline commands. Underlining may be invoked in any portion or portions of the line.

ESCAPE SEQUENCE	FUNCTION/COMMENT
ESC [4 m	(155) Start underline
ESC [m or ESC [0 m	Stop underline

GRAPHICS—The graphics program is completely controlled by the input device or computer, with the exception of the printer logic forcing a carriage return (CR) when the graphics buffer is full (872 codes).

In the graphics mode, a data byte consists of six bits of information representing one column of six adjacent rows. The host offsets the transmitted graphic data by adding 40 octal which puts the data out of the control code range of ASCII and into the printable range (octal 40-137). Control codes, transmitted without the offset (plus 40 octal), works the same way in the graphics mode with a vertical pitch of 12 LPI. The escape sequences for underline and change in horizontal pitch are ignored. Vertical margins are cleared by entering into the graphics mode.

In the graphics mode, if 872 graphic codes are sent in one line, the printer software forces a carriage return. With the automatic line feed enabled, a one-half line feed follows the carriage return. If the auto line feed is disabled, an overprint occurs unless a line feed code is sent after the 872 byte. In the graphics program the software converts the line feed code to a one-half line feed to prepare for the next graphic line.

A graphic line of less than 872 bytes can be terminated by sending a carriage return code. The auto line feed function also applies in this case.

ESC. SEQ./ CONT. CODE	FUNCTION/COMMENT
ESC % 0	Initiate unidirectional graphics mode.
ESC % 1	Initiate bidirectional graphics mode.
SO	(016) Exit graphics mode by selecting alternate character set.
SI	(017) Exit by selecting the primary character set.

VARIABLE SPACING—Variable spacing allows any character set to be right justified using a host device program. Right justification is accomplished by adjusting the width of the space between the words and/or characters. One space of variable spacing is = 1/330 inch in width which is = 1/2 of a print column.

ESCAPE SEQUENCE	FUNCTION/COMMENT
ESC [n a	(141) Variable spacing (n = 1 to 255)

ALTERNATE CHARACTER SETS—The five character sets in the Model 351 printer:

- Standard (7 × 9) alternate character set
- Proportional alternate character set
- Expanded proportional alternate character set
- Multipass proportional alternate character set
- Expanded multipass proportional alternate character set

NOTE

On power up, the default character set will be Proportional Alternate Character Set.

Standard Alternate Character Set—The standard alternate character set, as set by the factory, is the United States character set.

The standard alternate character set may be intermixed with any other character set on the same line.

To designate the standard alternate character set use:

ESCAPE SEQUENCE	FUNCTION/COMMENT
ESC) 0	(060)

Proportional Alternate Character Set —The proportional alternate character set is a variable width character set, the width of which varies from 6—23 dots.

To designate the proportional alternate character set as the alternate character set, use:

ESCAPE SEQUENCE	FUNCTION/COMMENT
ESC) 3	(063)

The proportional alternate character set may be intermixed with any other character set on the same line.

Expanded Proportional Alternate Character Set—The expanded proportional alternate character set is an expansion of the proportional alternate character set that was previously described.

To designate the expanded proportional alternate character set as the alternate character set, use:

ESCAPE SEQUENCE FUNCTION / COMMENT

ESC) 4 (064)

Figure 10-1, US ASCII Character Set, and Figure 10-2, European Character Set illustrations indicate the width of the individual characters.

MULTIPASS PROPORTIONAL ALTERNATE

CHARACTER SET—This is a variable width character set (the same width as the proportional alternate character set) and requires two passes of the print head to complete printing of the set.

The multipass proportional set is designated by one of the following sequences:

ESCAPE SEQUENCE FUNCTION / COMMENT

ESC) 5 (065) Bidirectional Multipass
ESC) 6 (066) Unidirectional Multipass

EXPANDED MULTIPASS PROPORTIONAL ALTERNATE CHARACTER SET—This is an expanded version of the multipass proportional character set described above.

The expanded multipass proportional set is designated by one of the following sequences:

ESCAPE SEQUENCE FUNCTION / COMMENT

ESC) 7 (067) Bidirectional Multipass
ESC) 8 (070) Unidirectional Multipass

This character set may be intermixed with any other character set on the same line.

To call up any of the preceding alternate character sets, use:

CONTROL CODE FUNCTION / COMMENT

SO (016)

To return to the primary character set, use:

CONTROL CODE FUNCTION / COMMENT

SI (017)

10.4 PROGRAMMING CONSIDERATIONS

The printer is controlled by the host device which must be programmed to provide the proper instructions to the printer for the desired outputs. The following is a summary of items which should be considered when programming the printer.

- On power-up the printer automatically defaults to the dip switch settings on the control panel.
- ESC sequences should not be sent during an INPUT PRIME. Centronics reserves this sequence for in-house testing.
- Underline is NOT terminated at the end of a line and continues until a stop underline command (ESC [0 m) is received.
- When the auto line feed after carriage return is disabled, paper is NOT advanced after printing. When in this mode all carriage return (CR) commands should immediately be followed by a line feed (LF) command to prevent overprinting.

CODE CHAR WIDTH	040 <i>Space</i> 7	041 ! 7	042 " 12	043 # 15	044 \$ 15	045 % 21	046 & 15	047 <i>Acute</i> 10
CODE CHAR WIDTH	050 (9	051) 9	052 * 15	053 + 15	054 <i>Comma</i> 7	055 <i>Hyphen</i> 15	056 <i>Period</i> 7	057 <i>Slash</i> 16
CODE CHAR WIDTH	060 0 15	061 1 15	062 2 15	063 3 15	064 4 15	065 5 15	066 6 15	067 7 15
CODE CHAR WIDTH	070 8 15	071 9 15	072 : 7	073 ; 7	074 < 15	075 = 15	076 > 15	077 ? 13
CODE CHAR WIDTH	100 @ 19	101 A 17	102 B 16	103 C 16	104 D 17	105 E 15	106 F 15	107 G 15
CODE CHAR WIDTH	110 H 17	111 I 9	112 J 14	113 K 15	114 L 14	115 M 21	116 N 17	117 O 17
CODE CHAR WIDTH	120 P 15	121 Q 17	122 R 15	123 S 15	124 T 15	125 U 16	126 V 17	127 W 21
CODE CHAR WIDTH	130 X 17	131 Y 17	132 Z 15	133 [10	134 \ 16	135] 10	136 ^ 15	137 <i>Underline</i> 12
CODE CHAR WIDTH	140 <i>Grave</i> 10	141 a 13	142 b 15	143 c 12	144 d 15	145 e 13	146 f 11	147 g 14
CODE CHAR WIDTH	150 h 15	151 i 9	152 j 11	153 k 13	154 l 9	155 m 23	156 n 15	157 o 13
CODE CHAR WIDTH	160 p 15	161 q 15	162 r 12	163 s 12	164 t 11	165 u 15	166 v 13	167 w 21
CODE CHAR WIDTH	170 x 13	171 y 15	172 z 13	173 { 12	174 <i>Rule</i> 13	175 } 12	176 ~ 15	177 DEL 13

Figure 10-1 US ASCII Character Set (With Proportional Character Width)

OCT	43	100	133	134	135	136	137	140	173	174	175	176
HEX	23	40	5B	5C	5D	5E	5F	60	7B	7C	7D	7E
USA WIDTH	# 15	@ 19	[10	\ 16] 10	^ 15	_ 12	` 10	{ 12	 13	} 12	~ 15
FRA WIDTH	£ 15	¢ 13	° 15	¶ 12	§ 12	^ 15	_ 12	` 10	é 13	ù 15	è 13	~ 17
UK WIDTH	£ 15	@ 19	[10	\ 16] 10	^ 15	_ 12	` 10	{ 12	 13	} 12	~ 15
GER WIDTH	# 15	§ 12	À 17	Ü 17	Ö 17	^ 15	_ 12	` 10	ä 13	ö 13	ü 15	ß 14
ITL WIDTH	£ 15	§ 12	° 15	é 13	ì 13	^ 15	_ 12	ù 15	è 13	ò 14	é 13	ì 9
S/F WIDTH	# 15	é 15	À 17	Ü 17	Ä 17	Ö 13	_ 12	` 10	ä 13	ö 13	ü 13	ü 15
D/N WIDTH	# 15	@ 19	Æ 21	Ø 17	À 17	Ö 13	_ 12	` 10	Æ 20	Ø 13	À 13	Ü 15
ESP WIDTH	£ 15	§ 12	í 7	Ñ 17	¿ 13	é 13	é 13	` 10	í 9	ñ 15	ó 13	ó 15

Figure 10-2 European Character Set (With Proportional Character Widths)

SECTION 11

PRINT GENERATION

11.1 GENERAL

The 351 printer operates in three different printing modes: single-pass mode, multipass mode, or graphics mode. This section provides information about the character sets used in the single-pass and multipass modes, and a summary of the operation of the graphics mode.

11.2 PRIMARY CHARACTER SET

The primary character set is the basic character set for single-pass mode operation. The set contains 96 standard US ASCII characters plus 34 characters peculiar to seven international character sets. All characters in the set are printed in a 7 x 9 matrix format.

Pin fire coding for the primary character set is stored in EPROM U55, which is located on the formatter/controller board.

NOTE

U55 stores pin fire data for the primary character set, the alternate character set and the proportional character set. Addresses 0 (H)-4FF (H) are reserved for the primary set; addresses 500 (H)-7FF (H) are reserved for the alternate set; and addresses 800 (H)-FFF (H) are reserved for the proportional set.

8 consecutive bytes of memory are required to code a single character. Starting addresses for the 96 US ASCII characters can be determined by multiplying the ASCII character codes by the number 8.

Example

Starting address for the US ASCII upper case "A":

$$\begin{array}{r} 41 \text{ (H) Character code, u.c. "A"} \\ \times 8 \\ \hline 208 \text{ (H) Starting address, u.c. "A"} \end{array}$$

Starting addresses for the international characters are determined the same way, but require the use of a translating table to determine character codes.

Any bytes in the primary reserved area (0 (H)-4FF (H)) not used to code printable characters are coded zero (0).

The primary character set uses approximately 25% of the memory in EPROM U55. The remainder of the memory is used to store the alternate character set. Although the primary set is stored in an erasable PROM, **THE FACTORY PROGRAMMED CODING FOR THE PRIMARY CHARACTER SET SHOULD NEVER BE ALTERED OR MODIFIED BY THE CUSTOMER.**

CAUTION

Altering or modifying the primary character set can cause the country code translation to be negated.

11.3 ALTERNATE CHARACTER SET

The alternate character set is one of two customer programmable sets for single pass mode operation. There are 96 characters in the set.

The characters in the set are printed in a 7 x 9 matrix format. The dots which form characters are impact printed by nine print wires in the print head. These nine wires are selectively fired as the print head moves across the paper.

The character set coding, which controls print head pin fire, is stored in 768 bytes in EPROM U55 on the formatter/controller pcb. These bytes have addresses 500 (H)-7FF (H).

The alternate character set is programmed for 96 US ASCII characters when the printer is shipped from the factory. Customers who have the necessary expertise and equipment can reprogram the set, nearly doubling the number of characters that can be printed in single-pass mode.

NOTE

The character set holds 94 formed characters; the first and last characters MUST always be a "SPACE" [ASCII 20 (H)] character.

CHARACTER CODING—Characters in the alternate character set are printed in a 7 x 9 matrix format. Individual characters are printed through the selective firing of the nine print head wires in seven consecutive volleys.

Figure 11-1 shows how one printed character of the set—a lower case “p”—is positioned on the matrix.

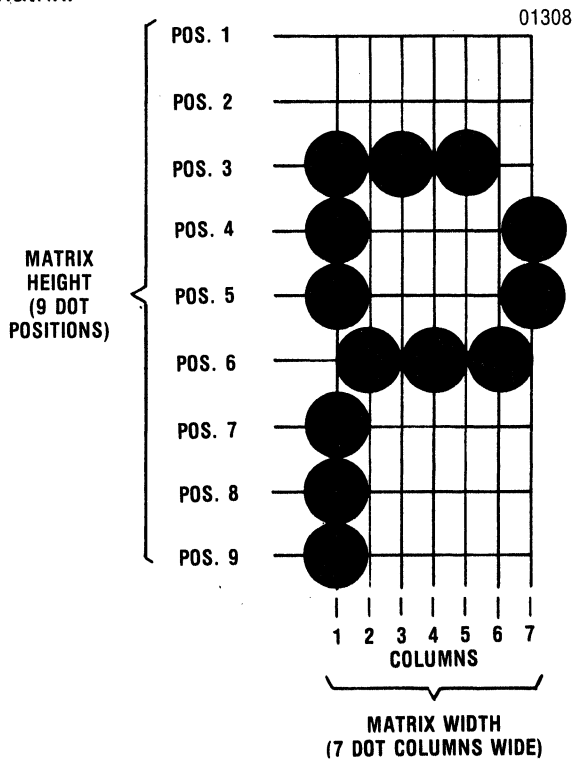

Figure 11-1 7×9 Matrix, Lower Case “P”

Note that the matrix is SEVEN DOT COLUMNS WIDE (each column is printed by one volley of pin fire) by NINE DOT POSITIONS HIGH (each dot is printed when one print wire is fired. Dot position 1 corresponds to print wire # 1, the top print wire in the head).

Notice that 13 dots form the lower case “p.” Other characters may use more or fewer dots, which will be positioned elsewhere on the matrix.

Since the matrix is 7×9, 63 dot positions are available for dot placement. Accordingly, each character requires 63 bits of memory to store pin fire data for character formation. The 63 bits used to store that data are always grouped as eight (8) contiguous bytes in the character set EPROM.

The format used to code the pin fire data in the contiguous bytes is as follows:

1. The first seven bytes control the firing of print wires 1 through 8. Byte 1 controls pin fire at dot column 1 on the matrix. The next six bytes control fire at the remaining six columns on the matrix.

Within bytes, each bit controls the firing of the corresponding numbered print wire. For

example, bit 3 is used to control the firing of print wire #3 (third wire from top).

2. The eighth contiguous byte contains the lower 8 bits of the ROM address for the two consecutive bytes that directly control the firing of print wire #9. The first of these two 8-bit bytes fires print wire #9 in the forward (left to right) direction and the second byte fires the print wire in the reverse (right to left) direction.

In all bytes but the eighth byte, a bit is coded “1” to cause a pin fire, and is coded “0” for no pin fire.

The coding for the lower case “p” shown in Figure 11-2 is as follows:

	BITS							
	8	7	6	5	4	3	2	1 (LSB)
First Byte	1	1	0	1	1	1	0	0
Second Byte	0	0	1	0	0	0	0	0
Third Byte	0	0	0	0	0	1	0	0
Fourth Byte	0	0	1	0	0	0	0	0
Fifth Byte	0	0	0	0	0	1	0	0
Sixth Byte	0	0	1	0	0	0	0	0
Seventh Byte	0	0	0	1	1	0	0	0
Eighth Byte*	0	1	0	0	0	1	1	0

*(This byte contains the LSB ROM address for the 2 contiguous bytes controlling print wire #9 firing data.)

Figure 11-2 shows the eight contiguous bytes rearranged and with bits coded “1” highlighted.

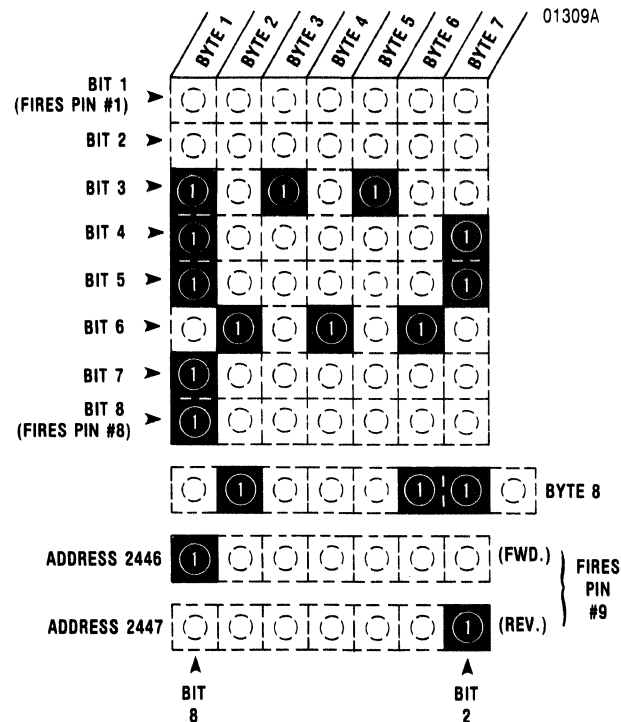

Figure 11-2 Character Coding, Lower Case “p”

Examination of the figure reveals the bits form a 7 x 9 matrix, like that shown in Figure 11-1. Note that except for print wire #9, the correspondence between the position of the highlighted "1"s in the coding matrix, and the dots on the character matrix; the correspondence is one to one.

The coding format described above is used for each of the 96 characters in the set.

Programming the Alternate Character Set—The customer programmable character set is stored in EPROM U55, a 2732A type IC. A 2732A is reprogrammed by exposing the device to ultraviolet light to erase its content, then loading new data into the 4096 bits in the device. After erasure, all bits go to a "1" state. New data is entered by loading "0"s into the proper bits.

Customers who reprogram the alternate character set **MUST RELOAD THE PRIMARY CHARACTER SET [address 0 (H) – 44F (H)] AND THE SINGLE PASS PROPORTIONAL CHARACTER SET [address 800 – FFF (H)] WITH THE SAME DATA THAT WAS STORED PRIOR TO ERASURE.** Refer to paragraph 11.2 for addressing, and to the previous paragraph for coding format.

NOTE

The Model 351 Technical Manual documents removal/replacement procedures and includes a complete set of assembly/schematic drawings.

The alternate character set, which is factory programmed for the standard 96 US ASCII character set, occupies addresses 500 (H) – 7FF (H).

As explained earlier, each character is assigned eight (8) contiguous addresses. The starting address for each character is determined by:

1. Determining the character code (refer to Figure 10-2).
2. Subtracting 20 (H) from the **HEX** character code.
3. Multiplying the obtained difference by eight (8).
4. Adding 500 (H) to the obtained product.

Example

Determining the starting address for the "QUOTES" character in the alternate set:

- | | | |
|----|------------------|-------------------------|
| 1. | 22 (H) | ASCII code for "QUOTES" |
| 2. | <u>– 20 (H)</u> | |
| | 02 (H) | Difference |
| 3. | <u>× 8</u> | |
| | 10 (H) | Product |
| 4. | <u>+ 500 (H)</u> | |
| | 510 (H) | Starting Address |

NOTE

Be sure to convert the OCTAL codes shown in Figure 10-1 to HEX when determining starting addresses.

There are three important rules that apply to programming the alternate character set:

- The first and last characters in the programmable set must always be coded as a SPACE; the remaining 94 characters can be programmed as printable characters.
- **NEVER** program a character that requires the same print wire to be fired in two consecutive print columns. **Printer hardware parameters are not broad enough to handle two consecutive firings of the same pin.**
- **NEVER** alter the factory programmed coding for the primary character set.

Refer to Section 10 for escape sequences (Selecting/Deselecting the Alternate Character Sets).

11.4 MULTIPASS CHARACTER SET

The 351 printer has one character set for multipass printing. The multipass character set is a doublepass, high resolution version of the proportional character set. Both sets contain identical characters (ref. paragraph 11.3). Characters in the multipass set are printed in a N x 18 dot matrix format.

A 351 multipass character is, in effect, two overlapping N x 9 characters. The first "character" is printed during the initial printing pass. The paper is then advanced slightly, and the second "character" is printed over the first.

Pin fire data for the multipass character set is stored in EPROM U56 on the formatter/controller pcb. U56 is divided into two sections. The first section (addresses 0 H–7FF H) contains pin fire data for first pass printing, while the second section (addresses 800 H–FFF H) stores data for the second pass.

The pin fire coding used for the multipass characters is involved and requires an in-depth understanding of the printer hardware parameters. Accordingly, **THE MULTIPASS CHARACTER SET SHOULD NOT BE ALTERED BY THE CUSTOMER.**

CAUTION

An improperly coded multipass character set can draw excessive current and result in component damage.

1 2 3 4 5 6	○ 32D 20H ○ ○ ○ ○ ○	● 33D 21H ○ ○ ○ ○ ○	○ 34D 22H ○ ○ ○ ○ ○	● 35D 23H ○ ○ ○ ○ ○	○ 36D 24H ○ ○ ○ ○ ○	● 37D 25H ○ ○ ○ ○ ○	○ 38D 26H ○ ○ ○ ○ ○	● 39D 27H ○ ○ ○ ○ ○
1 2 3 4 5 6	○ 40D 28H ○ ○ ○ ○ ○	● 41D 29H ○ ○ ○ ○ ○	○ 42D 2AH ○ ○ ○ ○ ○	● 43D 2BH ○ ○ ○ ○ ○	○ 44D 2CH ○ ○ ○ ○ ○	● 45D 2DH ○ ○ ○ ○ ○	○ 46D 2EH ○ ○ ○ ○ ○	● 47D 2FH ○ ○ ○ ○ ○
1 2 3 4 5 6	○ 48D 30H ○ ○ ○ ○ ○	● 49D 31H ○ ○ ○ ○ ○	○ 50D 32H ○ ○ ○ ○ ○	● 51D 33H ○ ○ ○ ○ ○	○ 52D 34H ○ ○ ○ ○ ○	● 53D 35H ○ ○ ○ ○ ○	○ 54D 36H ○ ○ ○ ○ ○	● 55D 37H ○ ○ ○ ○ ○
1 2 3 4 5 6	○ 56D 38H ○ ○ ○ ○ ○	● 57D 39H ○ ○ ○ ○ ○	○ 58D 3AH ○ ○ ○ ○ ○	● 59D 3BH ○ ○ ○ ○ ○	○ 60D 3CH ○ ○ ○ ○ ○	● 61D 3DH ○ ○ ○ ○ ○	○ 62D 3EH ○ ○ ○ ○ ○	● 63D 3FH ○ ○ ○ ○ ○
1 2 3 4 5 6	○ 64D 40H ○ ○ ○ ○ ○	● 65D 41H ○ ○ ○ ○ ○	○ 66D 42H ○ ○ ○ ○ ○	● 67D 43H ○ ○ ○ ○ ○	○ 68D 44H ○ ○ ○ ○ ○	● 69D 45H ○ ○ ○ ○ ○	○ 70D 46H ○ ○ ○ ○ ○	● 71D 47H ○ ○ ○ ○ ○
1 2 3 4 5 6	○ 72D 48H ○ ○ ○ ○ ○	● 73D 49H ○ ○ ○ ○ ○	○ 74D 4AH ○ ○ ○ ○ ○	● 75D 4BH ○ ○ ○ ○ ○	○ 76D 4CH ○ ○ ○ ○ ○	● 77D 4DH ○ ○ ○ ○ ○	○ 78D 4EH ○ ○ ○ ○ ○	● 79D 4FH ○ ○ ○ ○ ○
1 2 3 4 5 6	○ 80D 50H ○ ○ ○ ○ ○	● 81D 51H ○ ○ ○ ○ ○	○ 82D 52H ○ ○ ○ ○ ○	● 83D 53H ○ ○ ○ ○ ○	○ 84D 54H ○ ○ ○ ○ ○	● 85D 55H ○ ○ ○ ○ ○	○ 86D 56H ○ ○ ○ ○ ○	● 87D 57H ○ ○ ○ ○ ○
1 2 3 4 5 6	○ 88D 58H ○ ○ ○ ○ ○	● 89D 59H ○ ○ ○ ○ ○	○ 90D 5AH ○ ○ ○ ○ ○	● 91D 5BH ○ ○ ○ ○ ○	○ 92D 5CH ○ ○ ○ ○ ○	● 93D 5DH ○ ○ ○ ○ ○	○ 94D 5EH ○ ○ ○ ○ ○	● 95D 5FH ○ ○ ○ ○ ○

Figure 11-3 Graphic Pin Address Codes

11.5 GRAPHICS

The printer is placed in its graphics mode through downstream loaded commands. In the graphics mode pin fire is directly controlled by the host device. The printer merely responds to the pin-addressable graphics data it is sent and fires pins accordingly. No character sets are used in this mode.

Dot columns in the graphics mode are six (6) dot positions high. The top six (6) print head pins are selectively fired to form each column. Up to 872 columns may be printed in a single line.

GRAPHICS DATA CODING—64 different column patterns can be printed. Figure 11-3 shows all 64, and the decimal/hex code for each pattern. Note

that the first graphic code is 21 H, the starting code in the ASCII printable range.

Graphic coding is sent as contiguous bytes of data, with column printing following in corresponding order. The eighth data byte sent, for example, controls pin fire at the eighth column of print.

Before the printer will accept pin-addressable data, one of two escape sequences must be sent to the printer to place it in graphics mode. One sequence initiates a unidirectional graphic mode and the other a bidirectional mode.

The unidirectional sequence, shown below, should be sent when high-resolution graphics are to be printed:

ESC (1B, H)
 % (25, H)
 0 (30, H)

The bidirectional sequence, shown below, should be sent when speed is more important than exact pin registration:

ESC (1B, H)
 % (25, H)
 1 (31, H)

The printer print buffer can accept up to 872 bytes (one printed line) of graphic data. If more than 872 bytes are sent, the printer forces a carriage return. Subsequent data will then be printed:

- On the next line (after a line feed) if the automatic line feed feature is enabled (refer to Section 2).
- or
- On the same line (overprint) if ALF is disabled.

Graphic lines shorter than 872 print columns are terminated by sending a carriage return. Again, depending on ALF selection subsequent data will be printed on the next line or as an overprint.

The printer responds to graphic line feed (LF) codes according to the print on paper motion configuration that is selected. Refer to Section 2.

Vertical margins are ignored in the graphics mode, as are escape sequences for underline and change in horizontal pitch.

The graphics mode is exited by selecting either the primary or alternate character set.

S0 (0E, H)
 S1 (0F, H)

SAMPLE GRAPHIC CODING—Figure 11-4 illustrates a simple graphic formation printed in graphics mode. The graphic data that was sent to the printer to initiate the print is shown to the right.

The relationship between graphic coding and graphic printing is clearly shown in the figure.

Note that adjacent dots are used to form the graphic. **Consecutive pin fires are allowed in the graphics mode.**

01310

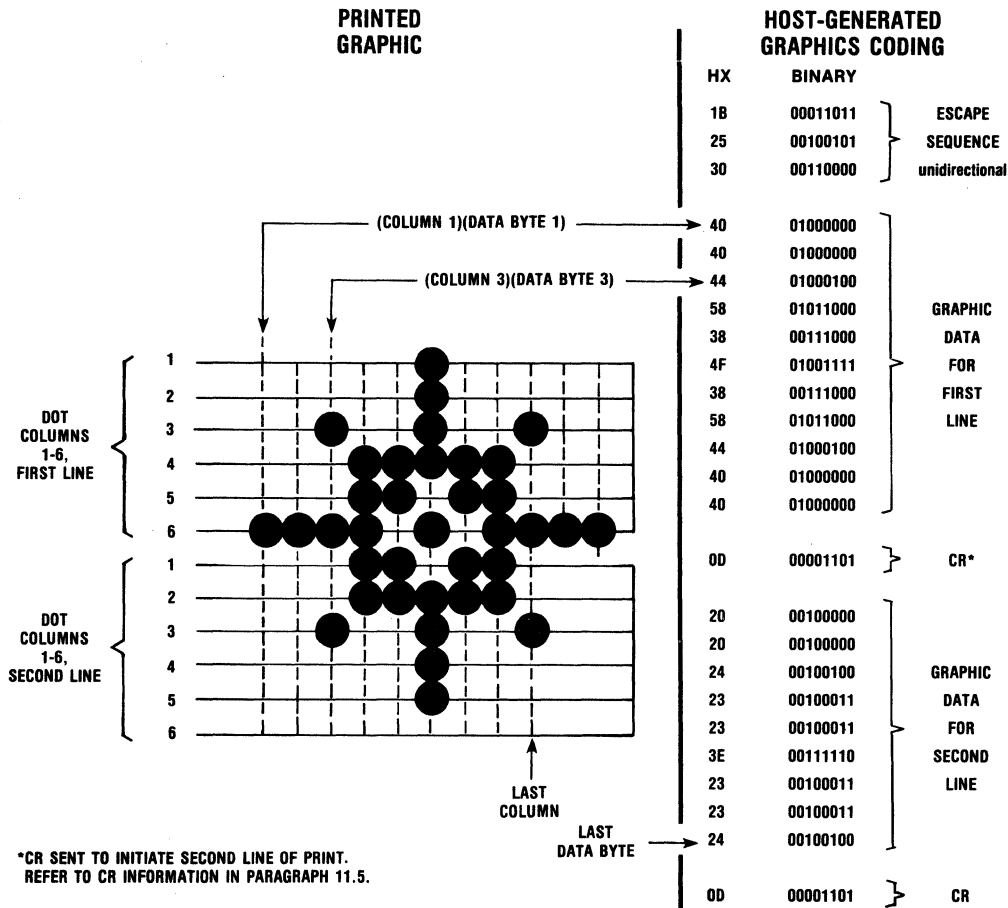

Figure 11-4 Graphics Coding/Printing

CONTENTS

Section 12 Options and Accessories

Options and Accessories

SECTION 12

OPTIONS AND ACCESSORIES

12.1 GENERAL

The standard printer may be equipped with various options and accessories to provide additional capabilities and easier operation. For easy installation, detailed instructions are provided with each option and accessory.

Purchase orders for options and accessories should be forwarded to:

Centronics Data Computer Corp.
Customer Service Department
1 Wall Street
Hudson, New Hampshire 03051

12.2 OPTIONS

The following options are available:

CURRENT LOOP INTERFACE—A 20 MA current loop capability is provided by an optional plug-in adapter board and current loop cable.

Order P/N 64000547-6001

DATA INPUT CABLES—Four shielded data cables are available.

- **Standard Parallel Cable**—This is the Centronics standard parallel interface cable. The 15 foot cable is terminated at either end with a 36-pin Molex connector.

Order P/N 39620034-1001

- **RS232 Cable**—This is the Centronics standard RS232 serial interface cable. The 10 foot cable is terminated at either end with a 25-pin connector.

Order P/N 39620033-1001

- **Current Loop Cable**—The 20 MA current loop cable is required when using the current loop interface. The 10 foot cable is terminated at one end with a 25-pin connector and at the other end with four ring terminals.

Order P/N 39620031-1001

- **IBM to Centronics Parallel Cable**—Used to connect the Centronics printer to an IBM personal computer. The cable terminates at one end with a 36-pin connector (printer connection) and at the other end with a 25-pin “D” series male connector.

Order P/N 39620035-1001

60/50 HZ CONVERSION—An optional field kit available to convert the printer from 115 VAC, 60 Hz to 220 VAC, 50 Hz or vice versa.

Order P/N 64000546-6001

PROM KITS—There are two PROM option kits currently available for the Model 351 which are described as follows.

- **Model 351 Modification Kit**—This PROM kit permits multipass printing in 5, 6, 10, or 12 cpi (horizontal pitch modes). Via escape sequences, the user may designate either the unidirectional or bidirectional character set.

Order P/N 64001101-6003

- **Model 351 Bar Code & Large Character Option Kit**—This PROM kit removes the proportional multipass printing feature of the Model 351 and replaces it with bar code/large character printing capability. The bar code formats include: Alpha 39 and 2 of 5 Interleaved.

Order P/N 64000193-6701

12.3 ACCESSORIES

The following accessories are available.

UNIVERSAL PRINT STAND—The universal print stand provides a rigid pedestal for mounting the printer. The stand contains a paper basket to catch, fold, and stack the printouts. The stand is available unassembled.

Order P/N 81100000-6170

RIBBON CASSETTES—70 yard throwaway ribbon cassettes are available in 4-pack kits.

ORDER P/N 64000520-6001

MODEL 351 TECHNICAL MANUAL—Provides detailed theory of operation, adjustment, and removal/replacement procedures.

ORDER P/N 37403510-6001

SERIES 350 ILLUSTRATED PARTS MANUAL—Provides a detailed breakdown of all printer assemblies down to the piece part level for parts ordering purposes.

ORDER P/N 37403502-6001

TOOL KIT—A tool kit containing all the necessary tools to maintain the printer.

ORDER P/N 63002399-6001

REPLACEABLE PRINT HEAD ASSEMBLY—The standard nine-wire print head used in Model 351. The print head removal/replacement procedure is described in Section 5 of this manual.

ORDER P/N 63180315-5001.

TABLE TOP FORMS STACKER KIT—Automatically stacks printed fanfold and cut sheet forms in a receiving tray mounted to the rear of the printer.

ORDER P/N 64000925-6001

DEMAND DOCUMENT WINDOW TEAR BAR—Permits form tearoff within 1 inch of last printed line.

P/N 64000819-2001

CONTENTS

Appendix A	Data Link Usage
Appendix B	Model 351-3 & 351-4 Printers

Appendix

APPENDIX A

DATA LINK USAGE

A.1 GENERAL

This addendum provides the information that the assembly language programmer will require to operate the Model 351 printer in a non-standard mode of communication. The circuitry permitting this type of operation in the 351 is called the Data Link. The major component in the Data Link is a 2732A E-PROM containing 4K x 8 of memory. Part of this memory (4K) is available for user modification of the following printer features and functions:

- Serial interface
- Parallel interface
- Two control panel membrane switches (F1 & F2)
- Serial buffer level
- One dip switch position
- Enabling of single-step paper motion
- Self-test printout
- Initialization
- Power-up switch settings

With the use of the Data Link, all dip switches (except the Data Link switch) can be overridden. 160 bytes of RAM are available.

A.2 LINK PROM FUNCTIONS

The PROM in the Data Link is used to control printer functions in Serial, Parallel, and both modes of operation as follows:

Serial Mode:

- Manipulate USART control (control byte)
- Create a custom status byte from configuration and operational status
- Direct the temporary storage of both received and transmitted data
- Manipulate high and low water marks in the input buffer

Parallel Mode:

- Decode incoming data and jump to an appropriate routine (either mainline or Data Link subroutine)
- Manipulate the parallel control lines

Serial and Parallel Modes:

- Generate multiple codes when one character code is received
- Decode non-standard data sequences

A.3 LINK PROM FORMATTING

The first 32 locations in the Data Link PROM are designated for 13 addresses, 2 parameters, and 2 flags. Any of the 32 locations that are not used must be programmed high (1 = 377 OCTAL or FF HEXADECIMAL). Any unused locations not programmed to a "one" state will be considered by the main program to be a usable parameter, flag, or routine address.

Table A-1 can be used as a ready reference of the user-addressable Data Link PROM locations. A detailed description of these addresses is included in this paragraph.

NOTE

All referenced addresses are addresses of user-generated routines located within the Link PROM.

CAUTION

Any damage incurred by writing or using any location in a manner not described in this manual is the user's responsibility.

Table A-1 User-Addressable Data Link PROM Locations

LOCATION	MNEMONIC	FUNCTION
3000H-3001H	DLINIT	Data Link Initialization
3002H-3003H	DLPAR	Data Link Parallel
3004H-3005H	DLSER	Data Link Serial
3006H-3007H	DLFUL	Data Link Full Count
3008H-3009H	DLEMP	Data Link Empty Count
300AH-300BH	DLBUSY	Data Link Busy
300CH-300DH	DLNBSY	Data Link Not Busy
300EH-300FH	DLLSW1	Data Link Local Switch 1
3010H-3011H	DLLSW2	Data Link Local Switch 2
3012H-3013H	DLSSW1	Data Link Select Switch 1
3014H-3015H	DLSSW2	Data Link Select Switch 2
3016H-3017H	DLDESL	Data Link Deselect
3018H-3019H	DLSEL	Data Link Select
301AH-301BH	DLSTST	Data Link Self-Test
301CH	DLSTEP	Data Link Single Step flag
301DH-301EH	DLSWLD	Data Link Switch Load
301FH	DLMULT	Data Link Multipass flag
3020H-3023H	DLREV	Data Link Revision Number
3024H-3FFFH	—	User Program Area

NOTE 1: If the user wishes to retain the Multipass Character set, the program area is limited to 3800H-3900H (256 bytes).

NOTE 2: When writing a program for the Link PROM, do not use I/O instructions (everything is memory mapped).

NOTE 3: Since the Model 351 printer is interrupt driven, NEVER mask or disable interrupts.

DLINIT (3000H-3001H)

Data Link Initialization—This address is used after the POWER-UP sequence. With this address, the user can initiate RAM and modify certain flags. The following RAM locations can be modified when DLINIT is used:

MAXVID (2-bytes)
MAXVDC (2-bytes)
CURCM1 (see note below)
CURCOM (see note below)
CCPI (1-byte)
CHSIZE (1-byte)
CURATS (1-byte)
ALTSET (1-byte)
CURIN (2-bytes)
CURCNT (2-bytes)

NOTE

Can be modified only when the serial port (8251A) is initialized.

DLPAR (3002H-3003H)

Data Link Parallel—This address is used when a character is transferred from the serial input buffer to the line buffer, or from the parallel port to the line buffer. Instructions on the use of main program subroutine data analysis is provided in paragraph A.5.

DLSER (3004H-3005H)

Data Link Serial—This address is used when a full character is received while the printer is in Serial Mode. Refer to paragraph A.5 for information on sequence of serial data reception.

DLFUL (3006H-3007H)

Data Link Full Count—This 16-bit number is used in Serial Mode only and indicates the input buffer high water mark (the number of characters in the input buffer required to indicate the buffer is full). This number cannot be less than DLEMP.

DLEMP (3008H-3009H)

Data Link Empty Count—This 16-bit number is used in Serial Mode only and indicates the input buffer low water mark (the number of characters in the input buffer when the full indication is removed). This number cannot be more than DLFUL.

DLBUSY (300AH-300BH)

Data Link Busy—This address is used when the printer is deselected or the input buffer is full.

DLNBSY (300CH-300DH)

Data Link Not Busy—This address is used when the printer is selected and the input buffer character count is at or above empty.

DLLSW1 (300EH-300FH)

Data link Local Switch 1—This address is used when the printer is not selected and panel membrane switch F1 is depressed.

DLLSW2 (3010H-3011H)

Data Link Local Switch 2—This address is used when the printer is not selected and panel membrane switch F2 is depressed.

DLSSW1 (3012H-3013H)

Data Link Select Switch 1—This address is used when the printer is selected and panel membrane switch F1 is depressed.

DLSSW2 (3014H-3015H)

Data Link Select Switch 2—This address is used when the printer is selected and panel membrane switch F2 is depressed.

DLDESL (3016H-3017H)

Data Link Deselect—This address is used as part of the Deselect Monitor Loop.

DLSEL (3018H-3019H)

Data Link Select—This address is used as part of the Select Monitor Loop.

DLSTST (301AH-301BH)

Data Link Self-Test—This address is used in Self-Test Mode only. The user's self-test is printed as part of the standard self-test after the switch settings and the standard self-test are printed out. To load the user's self-test, see paragraph A.7.

DLSTEP (301CH)

Data Link Single-Step Flag—This 8-bit flag is used to enable the single-step paper motion function with 0 = ENABLED. The escape sequence to use this function is in paragraph A.9.

DLSWLD (301DH-301EH)

Data Link Switch Load—This address is used during power-up to override the switch settings. It allows the user to power-up the printer in a non-standard configuration whereby some or all dip switches may be ignored. Refer to paragraph A.10 for the proper formatting to use this feature.

DLMULT (301FH)

Data Link Multipass Flag—This flag indicates to the main program that a multipass character set is present in the Link PROM. (0 = Proportional, 1 = Monospaced, FF = None.)

DLREV (3020H-3023H)

Data Link Revision Number—This is the location where four ASCII alphanumeric codes are placed to indicate the revision number of the Data Link. This number is printed out during the Self-Test printout.

USER PROGRAM AREA (3024H-3FFFH)

These locations may be used for user programming of the printer. If the user wishes to retain the Multipass Character set, **the user program area must be limited to 3800H-3900H (256 bytes).**

A.4 LINK PROM USAGE

The Data Link can be used to reprogram RAM locations in the printer's main program so that the printer configuration can be modified. A list and description of RAM locations follow in Table A-2.

Table A-2 RAM Locations

LOCATION	MNEMONIC	FUNCTION
4080	PWRUP	Have initialized printer (NZ = INITIALIZED)
4081	VIDEOX	Present encoder pulse count
4083	INCOUT	Count of character encoder pulse
4085	VIDMAX	Current maximum number of video interrupts
4087	NEXVEC	Next vector for video analysis
4089	BRANCH	RST 7.5 branch address
408B	NEXFIR	Forward or reverse pin fire, next vector
408D	VSEEK	Negative video—compare value
408F	RST75	Video Interrupt In flag (NZ)
4091	VSHOLD	Video Seek Hold byte
4093	EQUAL	Video Compare flag (0 = VIDEOX + VSEEK = 0)
4094	RABS	Absolute value VIDEOX, right margin start
4096	LABS	Absolute value VIDEOX, left margin start
4098	RFLAGS	Flags for VIDEOX, right margin start
409A	LFLAGS	Flags for VIDEOX, left margin start
40A0	CHPOS1	Character position, left
40A2	CHPOS2	Character position, right
40A4	AMOUNT	Character count, present print line
40A6	DIRECT	Carriage motor direction (FWD = 1, REV = 0)
40A8	SLOW	Speed for this line will be NZ = SLOW
40A9	HMBRAK	Brake flag (NZ = BRAKING)
40AA	SDARV	Serial data analysis routine vector
40AC	PAGFLG	Page Mode flag (NZ = ACTIVE)
40AD	EOPM	End of Page Mode flag
40AE	GRAF	31 = bidirectional, 30 = unidirectional
40AF	GRAFST	Start Graphics flag
40B0	GRFCNT	Temp current count of bytes left in line
40B2	GRFAD	½LF (Z = at baseline, NZ = not at baseline)
40B3	PLFAD	Partial Line Feed flag
40B4	CUTMOD	FF = in Cut Sheet Mode
40B5	LOADED	FF = Cut Sheet loaded
40B6	PININ	Point to put data into Pin Buffer
40B8	PINOUT	Point to take data out of Pin Buffer
40BA	PINCNT	Count of videos in Pin Buffer
40BB	CPP	Character Position pointer

Table A-2 RAM Locations (cont.)

LOCATION	MNEMONIC	FUNCTION
40BD	LFSTEP	Present number of steps per line 20 steps = 6 LPI Fanfold 18 steps = 6 LPI Cut Sheet 15 steps = 8 LPI Fanfold 13 steps = 8 LPI Cut Sheet 10 steps = Sub/Superscripts, Fanfold 9 steps = Sub/Superscripts, Cut Sheet 10 steps = Graphics line feed, Fanfold 9 steps = Graphics line feed, Cut Sheet
40BE	EOLF8C	Even/Odd LPI Cut Sheet for 13/14 steps
40BF	STEPS	Number of forward steps to do
40C1	REVSTP	Number of reverse steps to do
40C3	STEPER	NZ = Paper in motion
40C4	DAMP	Damping Step flag
40C5	RVSTF	NZ = Doing reverse steps
40C6	FDSTF	NZ = Doing forward steps
40C7	PHZTIM	Pointer into ramp table
40C9	POFFST	Phase table pointer offset
40CA	NXTPHZ	Next phase output
40CB	STPTYM	Stepper motor interrupt time
40CD	LASTX	Last X/ON or X/OFF flag
40CE	BCOM	Serial Busy command
40CF	NBCOM	Serial Not Busy command
40D0	BBRANC	PBUSY, S1BUSY, or SXBUSY branch address
40D2	NBRAN	PNBUSY, S1NBSY, or SXNBSY branch address
40D4	CUROUT	Current Output pointer
40D6	FULBUF	Two's complement, full buffer number
40D8	EMPBUF	Two's complement, empty buffer number
40DA	BUFULL	Buffer Full flag
40DB	DLENQ	Status Request flag
40DC	FUTURE	Future Offline flag
40DD	LAMPS	Save of the LED and Outside lines
40DE	BUTSAV	Flag for button Was Pushed and Acted On
40E0	BUTIME	Debounce time
40E1	SLTIME	Slew time count
40E2	IPSEL	Input Prime Select, local flag
40E3	TSTIN	Input Prime Go, Serial/Parallel flag
40E4	TAB	Vertical Tabs
40F4	HTAB	Horizontal Tabs
4104	INPONT	Pointer into the Input Buffer
4106	CURCOL	Current Column (character) in line (H. Tabs)
4108	ESCSCR	Escape sequence scratch

Table A-2 RAM Locations (cont.)

LOCATION	MNEMONIC	FUNCTION
4118	ESCCNT	Parameter number
4119	ESCFLG	Escape sequence flag
411A	CONTIN	Temporary location for saving this character
411B	PCODE	Control code to do something
411C	SCODE	Save code location
411D	AD12	Video adjust for 12 CPI
411E	COLCNT	Number of column for this character
411F	DATA9	9-pin data for this character
4121	EXPCH	Expand this character
4122	SIZCH	Size of this character
4123	UNLCH	Underline this character
4124	MULLIN	Multipass this line
4125	MULDIR	Unidirectional/bidirectional multipass print
4126	MULPAS	Pass number 1 or 2
4127	DLOOP	Data Link parallel, more characters to come
4129	DATAIN	Data interrupt RAM routine
4130	RSWPK1	Hold S1 byte
	FORMSL	(EQU) Bit 0 = ½ inch 1 = 1 inch 2 = 2 inch 3 = 4 inch 4 = 8 inch
	PRSEL	(EQU) 5 = Prime on Select
	PRDEL	(EQU) 6 = Prime on Delete 7 = Auto Line Feed
4131	RSWPK2	Hold S2 byte
	CTYMSK	(EQU) Bit 0 = Country Code 0 1 = Country Code 1 2 = Country Code 2
	SELFT	(EQU) 3 = Self-Test
	BDRMSK	(EQU) 4 = Baud 0 5 = Baud 1 6 = Baud 2
	LPI68	(EQU) 7 = 6/8 LPI (0 = 6, 1 = 8)
4132	RSWPK3	Hold S3 byte
	PARSER	(EQU) Bit 0 = 1 = Parallel, 0 = Serial
	MODE	(EQU) 1 = Page Mode, 1 = ENABLED, 0 = DISABLED
	RCPOL	(EQU) 2 = RC, 0 = Inverted RC
	RCDTR	(EQU) 3 = 1 = RC & DTR, 0 = RC
	PARITY	(EQU) 4 = 1 = Parity, 0 = No Parity
	EVEODD	(EQU) 5 = 1 = Even Parity, 0 = Odd Parity

Table A-2 RAM Locations (cont.)

LOCATION	MNEMONIC	FUNCTION
4132	XONOFF	(EQU) 6 = 1 = XON XOFF
	NEWLNE	(EQU) 7 = 1 = New Line Mode
4133	RSWPK4	Hold S4 byte
4134	NOPRIM	Don't prime flag
4135	GOSLIN	Address of serial/page character analyze
414B	MAXVID	Used only during DLINIT to change maximum line length in Fanfold Mode. Contains two's complement of maximum number of videos per line. Normally set to 4345 for a 13.2-inch line length. (330 × 13.2) – 11.
414D	MAXVDC	Used during DLINIT to change maximum line length in Cut Sheet Mode. Normally set to 3949 for 12-inch line (330 × 12) – 1.
414F	CURCM1	Current USART Mode instruction. (See 8251A specs.) Bit 0 + 1 = Baud Rate factor 1 = X1 2 = X16 (default value) 3 = X64 Bit 2 + 3 = Character length 0 = 5-bit character 1 = 6-bit character 2 = 7-bit character (switch selectable) 3 = 8-bit character (switch selectable) Bit 4 = Character length 0 = Disable 1 = Enable Bit 5 = Parity (switch selectable) 0 = Odd Parity 1 = Even Parity Bit 6 = 7 = Number of stop bits (TRANSMIT ONLY) 1 = 1 Stop bit 2 = 1.5 Stop bits 3 = 2 Stop bits (default value)
4150	CURCOM	Current USART command instruction (see 8251A instructions). NOTE: ERROR RESET (Bit 4) MUST ALWAYS BE SET TO "1". Bit 0 = 1 (Transmit Enabled) 1 = 1 (DTR Low) 2 = 1 (Receive Enabled)

Table A-2 RAM Locations (cont.)

LOCATION	MNEMONIC	FUNCTION
4150	CURCOM	<p>3 = 1 (Send Break [TXD Low]) 4 = 1 (Error Reset [RE, OE, FE]) MUST BE SET 5 = 1 (RC Low)* 6 = 1 (Internal Reset) 7 = 1 (Sync Hunt) Due to hardware restrictions, the 8251A USART cannot be used in SYNC mode. * = RTS is hardwired to RC</p>
4151	CCPI	<p>Current CPI for 7 × 9 character sets: 10, 12, 16.5, or EXPANDED. 10 CPI = 00000000B 12 CPI = 00000001B 16.5 CPI = 00000010B 5 CP! = 00001000B 6 CPI = 00001001B 8.25 CPI = 00001010B</p>
4152	CHSIZE	<p>Character size in videos (used in calculating the maximum number of characters per line). 10 CPI = 33 12 CPI = 27 16.5 CPI = 20 5 CPI = 66 6 CPI = 55 8.25 CPI = 40 Proportional character = OFF(H) (use character look-up table for video count.) Graphics Data = 5</p>
4153	CURATS	<p>Current attribute (if user changes this byte, CHSIZE must also be modified). Bits 0 + 1 = 0 = 10 CPI 1 = 12 CPI 2 = 16.5 CPI 3 = Proportional Bit 2 = 1 = Expanded Bit 3 = 1 = Underlined Bit 4 = 1 = Alternate Character Set (7 × 9) Bit 5 = 1 = Video Skips (not a character) Bit 6 = 0 (MUST BE SET TO "0" AT ALL TIMES)</p>

Table A-2 RAM Locations (cont.)

LOCATION	MNEMONIC	FUNCTION
4154	STATOT	Serial status byte (TRANSMIT ON STATUS REQUEST). Bit 0 = 0 = Paper OK = 1 = Paper Out Bit 1 = 0 = Selected = 1 = Deselected Bit 2 = 0 = Buffer Available = 1 = Buffer Full Bit 3 = 0 = No Reception Error = 1 = Reception Error Bit 4 – 7 = (NOT USED, but transmitted on request)
4155	ALTSET	Alternate Character Set designation. Proportional = 00000011B Expanded Proportional = 00000111B (7 × 9) Customer Programmable Set = 00010000B
4156	FORM	Number of lines per form.
4157	TOPM	Top margin line number (MUST BE GREATER THAN 0 AND LESS THAN BOTTOM MARGIN).
4158	BOTTOM	Bottom margin line number (MUST BE GREATER THAN 1, GREATER THAN TOP MARGIN, AND LESS THAN OR EQUAL TO FORM).
415A	NATION	Country Code byte. 0 = United States of America 1 = France (Francais) 2 = United Kingdom (England) 3 = Germany (Deutschland) 4 = Italy (Italia) 5 = Sweden/Finland 6 = Denmark/Norway 7 = Spain (Espana)
415B	CURIN	Input buffer pointer.
415D	CURCNT	Current number of characters in input buffer.
415F	SWITCH	Link PROM switch flag (NZ = OPEN). During Initialization, the main program stores in this location the positional status of dip switch S4, section 1 for use by the LINK PROM. DLSWLD (301DH-301EH) WILL NOT AFFECT THIS LOCATION.
4160-41FF	DLRAM	Data Link RAM. Only 160 bytes are dedicated for Link PROM use. DO NOT EXCEED THE RAM BOUNDARIES.

A.5 MAIN PROGRAM ROUTINES

There are eight main program routines that can be used by the Link PROM: four serial, 3 parallel, and one self-test. Seven of the routines can be used to modify printer data analysis.

PARALLEL DATA RECEPTION GUIDELINES

If the parallel port is used for data communications, the Link user will first write a data analysis routine and then place the starting address in DLPAR. When writing this routine, it should be noted that after a character is strobed in, the main program will read this character and then place it in Register A for analysis. A JMP DLPAR is then executed and program control is given to the link routine, the starting address of which is at DLPAR. If multiple character generation is needed during analysis, PARDOX is called.

PARDOX (EQU 0050)

PARDOX is used for multiple character generation. It differs from PARINT by inhibiting the acknowledgement of the character and the returning of control to the Link PROM. This makes it possible for the Link PROM to insert many characters while acknowledging only one. PARDOX takes the character in Register A, places it in the line buffer, but does not send an acknowledge via the parallel port. Control is returned to the Link PROM (DLPAR). With control codes, the return of control to the Link is delayed until after the function is performed.

After data analysis, control must be returned to the main program so that an acknowledge can be generated via the parallel port to the host computer. This is done by executing a JMP to one of the following routines.

ACKOUT (EQU 004D)

ACKOUT is used to ignore a character. It generates an acknowledge only if the printer is selected and is not in Page Mode, then returns control to the main program.

PARINT (EQU 0053)

PARINT is the main program routine used for normal parallel mode data reception. It takes the character in Register A, places it in the line buffer, then acknowledges the reception. With control codes, acknowledgement is delayed until the function is performed. Control is then returned to the main program.

SERIAL DATA RECEPTION GUIDELINES

If the serial port is used for data communications, the Link user first writes a data analysis routine and then places the starting address in DLSER.

When writing the routine, it should be noted that: after a full character is received by the USART, the main program places the character in Register B for analysis, and the USART status is placed in Register C.

If any errors are detected, the main program resets the error. If a break is detected, the USART is reset so that serial communications can continue. A JMP DLSER is then executed and gives program control to the Link routine starting at address DLSER. During analysis, the following routines can be called.

NOTE

Because the serial port is interrupt driven, the Link user must maintain data integrity by limiting routines to less than 3000 TS (time states).

INSERT (0044H)

INSERT places the character stored in Register B into the buffer, then bumps the buffer pointer (CURIN). If an overflow occurs, the pointer will not be bumped and the ZERO flag will be set.

REGISTERS USED: A, B, DE, and HL

BMPCNT (0047H)

BMPCNT increments the buffer count (CURCNT) and checks for a full buffer condition. CARRY is set on a full buffer condition.

REGISTERS USED: DE, HL

XMIT (004AH)

XMIT checks the status of the 8251A USART and waits for "ready to transmit". When ready, the character stored in Register B is transmitted.

REGISTERS USED: A, B

SER (005CH)

SER takes the character in Register B and places it into the input buffer, and modifies the status accordingly. Control is then returned to the main program. When testing for a certain input code, the Link User can jump to this location if it is not the desired code.

REGISTERS USED: ALL

A.6 COMMON FUNCTIONS

Included in this paragraph is a list of common functions and a description of how to perform the function in each communication mode.

SINGLE CHARACTER SUBSTITUTION

Serial Mode—Place the substitute character in Register B, then execute a JMP to SER (MAIN PROGRAM ROUTINE).

Parallel Mode—Place the substitute character in Register A, then execute a JMP to PARINT.

IGNORING A SINGLE CHARACTER

Serial Mode—Execute a RST 1 instruction.

Parallel Mode—Execute a JMP to ACKOUT.

MULTIPLE CHARACTER GENERATION

Serial Mode—All multiple character generation is done through the parallel data analysis routines when the data is transferred from the input buffer to the line buffer. DLPAR is used for this purpose in both Serial and Parallel Modes.

Parallel Mode—One character is placed in Register A, then PARDOX is called. Repeat this format for each character to be generated. To exit from Multi-Character Generation, the programmer can either:

- JMP to PARINT instead of calling PARDOX when generating the last character.

or:

- JMP to ACKOUT after generating the last character through a call to PARDOX.

A.7 SELF-TEST ROUTINE (DLSTLD)

DLSTLD is used by the Link PROM user to generate a custom self-test. One line can be generated with a variable number of characters, depending on the density of each character. To calculate the maximum number of characters (since characters can be mixed on a line), use Table E-2 under the RAM location CHSIZE. The maximum number of characters in a line is 4345 in Fanfold Mode and 3949 in Cut Sheet Mode.

To load the appropriate characters and have them printed in the proper density, generate a byte in the same format as RAM location CURATS and place it in Register B. Place the character to be generated in Register A, place the number of times that the character is to be repeated in Register C (**NEVER ENTER 0**), then call DLSTLD. After a full line of characters has been loaded, return control to the main program (by executing a RET) and the line will be printed.

A.8 ERROR ROUTINE

BOMB2 is the location in the main program when a fatal error indication is needed such as for a cyclic redundancy check (CRC) error. A PROM 2 CRC error indication will be generated and presented to the LEDs and the program will restart.

BOMB2 (EQU 0059)—No registers are saved: an error indication is made, then RST 0 is executed.

A.9 SINGLE-STEP OPTION

The use of the single-step option is enabled by programming DLSTEP to zero. The escape sequence to perform the single-step function is as follows:

ESC, [, n, 7BH (For **forward** paper motion steps)

ESC, [, n, 7CH (For **reverse** paper motion steps)

“n” is a positive integer no greater than 255

NOTE

Positional calculations are done on a line basis for vertical tabs, line feeds, margins, and top of form. Single steps are not used in these calculations.

A.10 SWITCH SET-UP

DLSWLD is called up by the main program during the power-up sequence (after RAM and CRC are tested). It can be used to test or override the switch settings. When the main program calls DLSWLD, Registers B through E will contain the switch settings. The user can test or modify any of the switch settings before they are used to initialize the printer. A list of the switch settings and the corresponding bit positions follows:

All settings, 1 = OPEN = ACTIVE

Register B: Forms length (in inches; Bits 0-4 are added together), Prime on Select/Delete, Auto Line Feed

- Bit 0 = ½ Inch
- 1 = 1 Inch
- 2 = 2 Inch
- 3 = 4 Inch
- 4 = 8 Inch
- 5 = Prime on Select
- 6 = Prime on Delete
- 7 = Auto Line Feed

Register C: Country Code, Self-Test, Baud Rate, 6/8 LPI

Bits 0-2 = Country:

- 0 = United States
- 1 = France
- 2 = United Kingdom
- 3 = Germany
- 4 = Italy
- 5 = Sweden/Finland
- 6 = Denmark/Norway
- 7 = Spain

Bit 3 = Self-Test Mode

Bits 4-6 = Baud Rate Code: Lo/Hi (see Register E)

- 0 = 50/1800
- 1 = 75/2000
- 2 = 110/2400
- 3 = 134.5/3600
- 4 = 150/4800
- 5 = 300/7200
- 6 = 600/9600
- 7 = 1200/19200

Bit 7 = 6/8 LPI (0 = 6, 1 = 8)

Register D: Parallel/Serial Operation: Page Mode, Parity/No Parity, Odd/Even Parity, XON-OFF Enabled/Disabled, New Line Mode

- Bit 0 = Parallel (1)/Serial (0)
- Bit 1 = Page Mode: Enabled (1)/Disabled (0)
- Bit 2 = + Reverse Channel (1)/ – Reverse Channel (0)
- Bit 3 = Reverse Channel and DTR (1)/Reverse Channel (0)
- Bit 4 = Parity (1)/Odd Parity (0)
- Bit 5 = Even Parity (1)/Odd Parity (0)
- Bit 6 = XON-XOFF Enabled (1)/Disabled (0)
- Bit 7 = New Line Mode: Enable (1)/Disable (0)

Register E: Data Link Accessed, HI/LO Baud Rate, 7/8 Data Bits

- Bit 0 = Data Link (not changeable)
- Bit 1 = Baud Rate: HI (1)/LO (0)
- Bit 2 = 7 Data Bits (1)/8 Data Bits (0)

A.11 INPUT/OUTPUT LOCATIONS

There are only two input/output locations that should be written to by a Link PROM routine: These locations are:

UARTC (6001H)

This is the 8251A USART serial port. It is written to when the Mode/Command of the USART is to be changed.

ALARM (7E00H)

A write to this address will activate the alarm buzzer for a period of approximately one second.

APPENDIX B

MODEL 351-3 & 351-4 PRINTERS

B.1 MODEL 351-3 PRINTER

The Model 351-3 printer is identical, both functionally and mechanically, to the Model 351 printer described previously, except the proportional spaced multipass character set is replaced by a monospaced multipass character set. This feature is determined by the EPROM (P/N 35522732-1A28) situated in socket location U56. The Model 351-3 is powered by 110 Vac, 60 Hz.

B.2 MODEL 351-4 PRINTER

The Model 351-4 printer is identical to the Model 351-3 printer described above, except it is a 220 Vac, 50 Hz model.

B.3 ESCAPE SEQUENCES

All of the escape sequence information described in Section 10 for the Model 351 printer is valid for the 351-3 and 351-4 printers except the information on the multipass proportional alternate character set. Escape sequence information for its

replacement, the multipass monospaced alternate character set, follows.

MULTIPASS MONOSPACED ALTERNATE CHARACTER SET—This character set requires two passes of the print head to complete printing of the set.

The multipass monospaced alternate character set is designated by one of the following sequences:

ESCAPE SEQUENCE	FUNCTION/COMMENT
ESC) 1	(061) Bidirectional multipass
ESC) 2	(062) Unidirectional multipass

B.4 DOCUMENTATION

All documentation and manuals cited for the Model 351 printer in Section 1 of this manual are applicable to the Model 351-3 and 351-4 printers.

OPTIONS/ACCESSORIES ORDER FORM (350 SERIES PRINTERS)

CENTRONICS PART NUMBER	OPTION / ACCESSORY DESCRIPTION	QUANTITY ORDERED	LIST PRICE	ITEM TOTAL
37403510-6001	Technical Manual Package, Model 351		\$ 45	
37403520-6001	Technical Manual Package, Model 352		\$ 45	
37403530-6001	Technical Manual Package, Model 353		\$ 45	
37403511-6001	Users Manual Package, Model 351		\$ 14	
37403521-6001	Users Manual Package, Model 352		\$ 14	
37403531-6001	Users Manual Package, Model 353		\$ 14	
37403502-6001	Illustrated Parts Manual Pkg., 350 Series		\$ 20	
39620031-1001	Current Loop Cable		\$ 25	
39620033-1001	RS 232 Cable		\$ 30	
39620034-1001	Standard Parallel Cable		\$ 65	
39620035-1001	IBM/Centronics Parallel Cable		\$ 65	
63180315-5001	Replaceable Print Head		\$135	
64000520-6001	Ribbon Cassettes, 70 yd., 4 pack		\$ 94	
64000546-6001	60/50 Hz Conversion		*	
64000547-6001	Current Loop Interface		\$100	
64000819-2001	Demand Document Window Tear Bar		\$ 25	
64000925-6001	Table Top Forms Stacker Kit		\$ 28	
81100000-6170	Universal Print Stand		\$150	

* Prices not available at time of publication.

SALES TAX
ORDER TOTAL

SHIP TO:

Dept. _____ Phone Number _____

Firm Name _____

Address _____

City _____ State _____ Zip _____

Customer Number _____ Purchase Order Number _____

Ordered by _____

BILL TO: (if different from "SHIP TO")

Dept. _____ Phone Number _____

Firm Name _____

Address _____

City _____ State _____ Zip _____

Customer Number _____

Attention of _____

PAYMENT METHOD:

UPS COD CHECK ENCLOSED (We pay freight) BILL ME (Current CDCC customers only)

PAYMENT TERMS:

For orders less than \$100.00:

Will be shipped UPS COD; unless payment for the full amount of the order, including sales tax, is enclosed.
With prepayments we pay the shipping costs.

For orders in excess of \$100.00:

Same terms as above; or, if you currently have an account with Centronics, we can bill you.

Prices subject to change without notice.



NO POSTAGE
NECESSARY
IF MAILED
IN THE
UNITED STATES

BUSINESS REPLY CARD
FIRST CLASS PERMIT NO. 31 HUDSON, N.H. 03051

Postage will be paid by addressee:

CENTRONICS®
Centronics Data Computer Corp.
1 Wall Street
Hudson, New Hampshire 03051

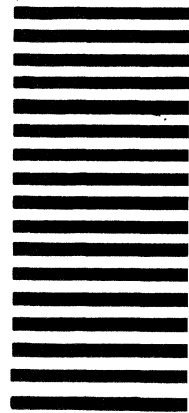

ATTN: PARTS / ACCESSORIES CUSTOMER SERVICE

READERS COMMENTS

Publications Title Model 351 Users Manual

Publications No. 37403511-9B20 Revision B2 Date April 1984

List PCP's, if any, received with manual: _____

Name _____ Company _____

Address _____ City _____ State _____ Zip _____

The intent of this manual is to provide accurate and meaningful information to help you properly operate and efficiently maintain equipment manufactured by Centronics Data Computer Corp. To this end, we welcome your comments regarding any errors, discrepancies or omissions you may have discovered, or any suggestions for improving the overall manual. This postage-paid form is provided for your convenience. Your comments will be appreciated and should be a useful input at the next revision of this manual.

TECHNICAL OR CLERICAL ERRORS:

(Specify Page Numbers)

SUGGESTIONS FOR IMPROVEMENT:

CENTRONICS®

Centronics Data Computer Corp.
1 Wall Street
Hudson, New Hampshire 03051
Tel. (603) 883-0111

Fold



NO POSTAGE
NECESSARY
IF MAILED
IN THE
UNITED STATES

BUSINESS REPLY CARD

FIRST CLASS PERMIT NO. 31 HUDSON, N.H. 03051

Postage will be paid by addressee:

CENTRONICS®

Centronics Data Computer Corp.
1 Wall Street
Hudson, New Hampshire 03051

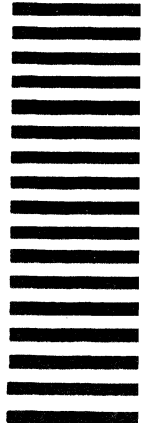

Attn: Technical Publications

Fold

CENTRONICS SALES & SERVICE
SERVICE INFORMATION FOR YOUR PRINTER MAY BE
OBTAINED BY CALLING THE NUMBERS LISTED BELOW.
(ASK FOR FIELD ENGINEERING)

NOTE

This list supersedes the contents of the similar list provided on the back of the manual cover.

CENTRONICS®

Centronics Data Computer Corp.
Hudson, New Hampshire 03051
Tel. (603) 883-0111, TWX. (710) 228-6505, TLX. 94-3404
Field Engineering Headquarters (603) 883-0111

Regional Sales Offices

Mid-Atlantic Region (NJ):	Tel. (609) 234-8266, TWX. 710-897-1975
Southern Region (TX):	Tel. (817) 461-5711, TWX. 910-890-4916
Western Region (CA):	Tel. (714) 979-6650, TWX. 910-595-1925
Northwest Region (CA):	Tel. (408) 744-1244, TWX. 910-339-9324

District Field Engineering Offices

Northeast District:	Tel. (516) 496-3506
Mid-Atlantic District:	Tel. (609) 234-8194
Midwest District:	Tel. (312) 956-6141
Southern District:	Tel. (817) 461-7121
Western District:	Tel. (714) 957-1944

International Offices

Centronics Data Computer (Canada) Ltd.
Mississauga, Ontario
Tel. (416) 625-0770, TWX. 610-492-4382

Centronics Data Computer—
European Headquarters
London SW73HA, United Kingdom
Tel. 441-581-1001, TLX. 8951373

Centronics Data Computer (France)
71-73 Rue Desnouettes, 75015 Paris, France
Tel. 828-4051, TLX. 202686

Centronics Data Computer (Germany), Gmbh
6000 Frankfurt am Main 71
Tel. 666-6748, TLX. 841-413224

Centronics (Italia) S.P.A.
Archielle Grandi 10
Cologno Monzese, Milano, Italy
Tel. 02-253-7841

Centronics Ireland B.V.
Industrial Estate
Donore Road
Drogheda, Co. Louth
Republic of Ireland
Tel: 011-353-41-8991/31243/31244/31081/31082
Tlx: 31866 CENT EI

Centronics Sales and Service Walk-In Service Centers

6649 Peachtree Industrial Blvd.
Suite J
Norcross, GA 30092
Tel. (404) 447-6530

16359 N.W. 57th Avenue
Miami Lakes, FL 33014
Tel. (305) 621-0125

1 Wall Street
Hudson, NH 03051
(603) 883-0111, Ext. 4227

North Shore Atrium
231-04 Robbins Lane
Syosset, NY 11791
Tel. (516) 931-8620

137 Galther Drive, Suite D
Mt. Laurel, NJ 08054
Tel. (609) 234-8194

738 W. Algonquin Road
Arlington Heights, IL 60005
Tel. (312) 956-6141

1900 East Randol Mill Road
Suite 103
Arlington, TX 76011
Tel. (817) 461-7121

17881 Skypark Circle
Suite H
Irvine, CA 92714
Tel. (714) 261-9444

554 Weddell Avenue, Suite 5
Sunnyvale, CA 94086
Tel. (408) 745-7040

