

CONTROL DATA DISK STORAGE UNIT

BR5A5A/B/C/D/E

**GENERAL DESCRIPTION
OPERATION
INSTALLATION AND
CHECKOUT
THEORY OF OPERATION
MAINTENANCE**

CONTROL DATA

CORPORATION

CUSTOMER ENGINEERING MANUAL

LIST OF EFFECTIVE PAGES

Sheet 1 of 1

New features, as well as changes, deletions, and additions to information in this manual are indicated by bars in the margins or by a dot near the page number if the entire page is affected. A bar by the page number indicates pagination rather than content has changed.

PAGE	REV	PAGE	REV	PAGE	REV	PAGE	REV	PAGE	REV
Cover	-	4-6	E	6-1	F	6-44	D		
Blank	-	4-7	E	6-2	F	6-45	D		
Title P	-	4-8	E	6-3	F	6-46	F		
ii	F	4-8.1	F	6-4	D	6-47	D		
iii	F	Blank	-	6-5	D	6-48	D		
Blank	-	4-9	F	6-6	D	6-49	F		
v	F	4-10	D	6-7	D	6-50	F		
Blank	-	4-11	D	6-8	D	6-51	F		
vii	F	4-12	F	6-9	D	6-52	F		
viii	F	4-13	F	6-10	D	6-52.1	F		
ix	F	4-14	F	6-11	F	Blank	-		
Blank	-	4-15	D	6-12	F	6-53	F		
S-1 Div	-	4-16	F	6-13	F	6-54	D		
Blank	-	4-17	F	6-14	D	6-55	D		
1-1	D	4-18	F	6-14.1	F	6-56	E		
1-2	D	4-19	F	Blank	-	6-57	F		
1-3	E	4-20	F	6-15	F	6-58	F		
1-4	D	4-21	F	6-16	D	6-59	F		
S-2 Div	-	4-22	D	6-17	D	6-60	F		
Blank	-	4-23	D	6-18	F	6-61	F		
2-1	D	4-24	D	6-19	F	6-62	F		
2-2	D	4-25	D	6-20	F	6-63	A		
2-3	D	4-26	D	6-21	D	Blank	-		
2-4	D	4-27	D	6-22	F	S7-10 Div	-		
2-5	D	4-28	D	6-23	D	Blank	-		
2-6	D	4-29	D	6-24	D	Cmt Sht	-		
2-7	D	4-30	D	6-25	F	Rtn Env	-		
Blank	-	4-31	D	6-26	F	Blank	-		
S-3 Div	-	4-32	D	6-27	D	Cover	-		
Blank	-	4-33	D	6-28	F				
3-1	F	4-34	D	6-29	D				
3-2	F	4-35	D	6-30	D				
3-3	E	4-36	F	6-30.1	D				
3-4	F	4-37	D	Blank	-				
3-5	E	4-38	D	6-31	D				
3-6	F	4-39	D	6-32	D				
3-7	E	4-40	F	6-33	D				
3-8	D	4-41	F	6-34	F				
3-9	D	4-42	F	6-35	D				
3-10	F	4-43	F	6-36	F				
S-4 Div	-	4-44	D	6-37	F				
Blank	-	4-45	F	6-38	F				
4-1	D	4-46	D	6-39	F				
4-2	E	S-5 Div	-	6-40	D				
4-3	E	Blank	-	6-41	D				
4-4	E	S-6 Div	-	6-42	D				
4-5	E	Blank	-	6-43	E				



PREFACE

Customer engineering material for the CONTROL DATA® BR5A5 Disk Storage Unit is contained in three separate manuals and provides all the information needed to install, operate and maintain the unit.

Publication No. 83302300

General Description, Operation
Installation and Checkout, Theory,
of Operation, Maintenance

Publication No. 83302400

Diagrams, Maintenance Aids,
Wire Lists

Publication No. 83302500

Parts Data



CONTENTS

1. GENERAL DESCRIPTION		AC/DC Distribution	4-22
Introduction	1-1	Power-On Sequence	4-24
Equipment Specifications	1-2	Power-Off Sequence	4-26
2. OPERATION		Logic Chassis	4-28
Controls and Indicators	2-1	Deck Assembly	4-28
Operating Instructions	2-5	Drive Motor Assembly	4-30
DSU Power Application	2-5	Hysteresis Brake Assembly	4-30
Disk Pack Installation	2-5	Spindle Assembly	4-31
Disk Pack Removal	2-6	Actuator	4-32
3. INSTALLATION AND CHECKOUT		Transducers	4-39
Uncrating	3-1	Disk Cleaner Assembly	4-41
Space Allocation	3-2	Blower System	4-44
Leveling and Aligning	3-2	Disk Pack	4-44
Cabling and Connections	3-4	6. MAINTENANCE	
Cabinet Intracabling	3-4	Maintenance Tools	6-1
Input/Output Cables	3-4	Maintenance Materials	6-2
Power Cables	3-6	Preventive Maintenance	6-3
Ground Bond	3-6	General	6-3
Cabinet Accessories	3-6	Preventive Maintenance Index	6-3
Input Power Requirements	3-7	Inspect and Clean Disk Pack	6-4
Environment	3-7	Inspect Actuator Assembly	6-5
Initial Checkout and Start-up Procedure	3-7	Clean Front Cover Glass	6-5
4. THEORY OF OPERATION		Change Primary Filter	6-6
Functions	4-1	Check Power Supply Outputs	6-7
First Seek	4-8	Inspect and Clean Read/Write Heads	6-8
Direct (Forward/Reverse) Seek	4-10	Clean Shroud and Spindle	6-9
Servo Circuit Functions	4-13	Check Pack Cleaning Brushes	6-9
Return to Zero Seek (RTZS)	4-19	Clean and Lubricate Lockshaft	6-10
Read/Write/Erase	4-20	Replace Absolute Filter	6-11
Assemblies	4-21	Corrective Maintenance	6-11
Power Supply	4-21	Read/Write Heads	6-11

Drive Belt Removal and Replacement	6-22	Position Transducer	6-43
Drive Motor Removal and Replacement	6-24	Head Select Preamplifier Card Removal and Replacement	6-43
Drive Motor Pulley Removal and Replacement	6-26	Heads Loaded Switch	6-44
Hysteresis Brake or Belt Removal and Replacement	6-27	Velocity Transducer	6-45
Spindle Lock Pawl	6-28	Carriage Alignment	6-48
Pack On Switch	6-29	Position Transducer	6-50
Ground Spring Check and Adjustment	6-30	DC Offset Check	6-56
Spindle and Lockshaft Assembly	6-31	Velocity Gain Check/Adjustment	6-57
Index Sensor Assembly	6-34	Fine Position Gain Check/Adjustment	6-59
Shroud Adjustment	6-40	Integrator Gain Check/Adjustment	6-61
Disk Cleaner Assembly	6-41		

FIGURES

2-1 Controls and Indicators	2-2	4-12 Head Loading	4-35
3-1 Cabinet Intracabling Diagram	3-3	4-13 Head/Arm Assembly Motion	4-38
3-2 System Intercabling	3-6	4-14 Index/Sector Detection	4-39
4-1 Input/Output Signal Gating	4-2	4-15 Velocity Detection	4-40
4-2 Select Sequence	4-2	4-16 Position Transducer/Simplified Detection	4-41
4-3 Block Diagram	4-3	4-17 Transducer Winding Induction	4-42
4-4 Servo Circuit Block Diagram	4-11	4-18 Track and EOT Pulses	4-43
4-5 Typical Servo Signal Relationships	4-12	4-19 Blower System	4-45
4-6 Fine Position Servo Signals	4-19	6-1 Cabinet Filters	6-6
4-7 Power Supply - AC/DC Distribution	4-23	6-2 Pack Cleaning Brushes	6-10
4-8 Power Supply - Sequencing	4-25	6-3 Head Adjustment Trace	6-14
4-9 Deck Assembly	4-29	6-4 Head/Arm Assembly Adjustment	6-14
4-10 Spindle Assembly	4-32	6-5 Head/Arm Replacement	6-16
4-11 Actuator Assembly Elements	4-33		

6-6	Head/Arm Installation or Removal	6-17	6-16	Index-Sector Transducer Trace	6-40
6-7	Symmetry Adjustment	6-20	6-17	Disk Cleaner Adjustment	6-41
6-8	Read Oscillator Output Waveform	6-21	6-18	Read/Write Head Cable Connections	6-43
6-9	Figure Deleted		6-19	Velocity Transducer Replacement	6-47
6-10	Main Deck Underside	6-23	6-20	Carriage Alignment	6-49
6-11	Motor and Brake Assembly	6-25	6-21	Position Transducer	6-53
6-12	Fixed Transducer and Thermo Compensation Tube Installation	6-33	6-22	Velocity Gain Adjustment	6-58
6-13	Index-Sector Sensor	6-35	6-23	Fine Position Gain Adjustment	6-60
6-14	Detector Trace	6-37	6-24	Integrator Gain Adjustment	6-63
6-15	Index to Burst Period	6-38			

TABLES

3-1	Input/Output Connector Pin Assignments	3-4	4-1	Input/Output Lines	4-4
3-2	Switch Setting for Logic Card at A16	3-10	6-1	Read/Write Head Replacement	6-1

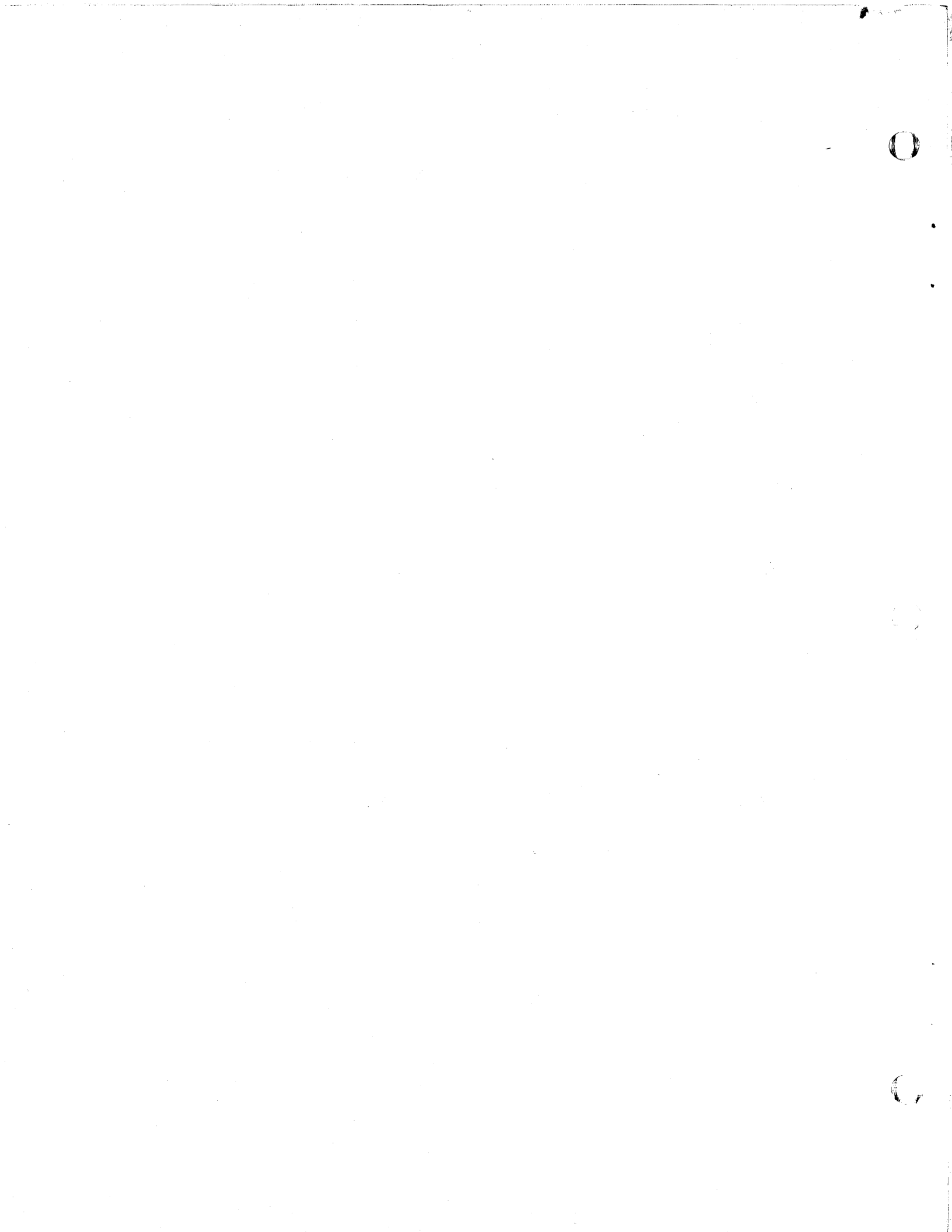

SECTION 1

GENERAL DESCRIPTION



GENERAL DESCRIPTION

The CONTROL DATA Disk Storage Unit is a high speed, random access, data storage device that interfaces with a central processor via a control unit.

The electro-mechanical Disk Storage Unit (DSU) positions its read/write heads to discrete positions or tracks over spinning disk surfaces. Data, in the form of magnetized bits or spots, is written on or read from the disk surfaces by the read/write heads.

The disk pack assemblies used by the DSU are mechanically interchangeable and magnetically compatible with any other BR5A5 DSU. Disk packs that have been written on 100 TPI media compatible* units can be read on this DSU by configuring the controller to skip odd-numbered cylinders.

The DSU consists of a deck assembly, a logic chassis, a power supply, and a frame.

The deck assembly contains the access mechanism, the speed and location sensing devices necessary to position the read/write heads, and four Silicon Peripheral Logic (SPL) cards involved in read/write operations. This assembly also includes the mounting and operational facilities required by the disk pack: spindle assembly, spindle drive motor, and shroud. The shroud surrounds the disk pack and thereby minimizes the possibility of damage to the read/write heads and disk surfaces caused by ingestion of dust.

A hinge-mounted logic chassis assembly is the mounting point for the main complement of the logic cards used by the deck; four cards are mounted on the deck assembly. Cards for the cabinet are mounted in a single row (A).

*Media compatible refers to the ability to interchange a disk pack between a spindle of this unit and a spindle of an IBM 2314-type device while continuing to perform within specification in each application.

A solid-state power supply assembly provides ± 5 , ± 20 , ± 36 , and $+40$ -vdc outputs.

A frame assembly provides the required mounting structure for the previously mentioned assemblies. In addition to the structural elements, this assembly contains the operator controls for the deck and a blower assembly. The output of the blower assembly is ducted to the deck assembly to provide positive pressurization of the disk pack and shroud area. It also provides cooling air to the power supply and logic chassis.

EQUIPMENT SPECIFICATIONS

The equipment specifications for the DSU are as follows:

ACCESSING TIME

Maximum Access Time (0-405 track seek)	70 ms
Maximum Access Time (0-202 or 203-405 track seek)	50 ms
Maximum One-Track Access Time	10 ms
Average Access Time (0-405 track range)	35 ms
Average Access Time (0-202 or 203-405 track range)	25 ms

RECORDING

Mode	Double frequency
Density (nominal)	1530 bpi (outer track) 2220 bpi (inner track)
Bit Rate (nominal)	2.50 MHz
Data Transfer Rate	312,500 characters/second
Bits/Character	8
Character/Track	7,812
Tracks/Cylinder	20
Cylinders/DSU	400 + 6 spares
DSU/System	8 maximum

DATA CAPACITY	62,500 nominal
Bits/Track	1,250,000 nominal
Bits/Cylinder	500,000,000 nominal
Bits/DSU	
DISK PACK	
Disks/Disk Pack	11
Useable Recording Surfaces/ Disk Pack	20
Disk Surface Diameter	14 inches
Recording Diameters	Track 405 (Inner) 8.980 in. nominal Track 0 (Outer) 13.200 in. nominal
Disk Surface Coating	Magnetic Oxide
Disk Pack Velocity	2400 ± 2% rpm
READ/WRITE HEADS	
Heads/Unit	20
Read/Write Track Width	0.004 in.
Track Spacing	0.005 in.
Read/Write to Erase Gap	0.010 in.
PHYSICAL - EACH CABINET	
Height	38 in. (96.52 cm)
Width	27.5 in. (69.85 cm)
Depth	37.5 in (95.25 cm)
Weight	660 lbs. (299.38 kg)
ELECTRICAL	
Power Source	
BR5A5-A/C/D	208v (+10, -8%), 60 ± 0.5-Hz, three-phase (two used)
BR5A5-B/E	220v (+10, -8%), 50 ± 0.5-Hz, three-phase (two used)

Surge Current

22 amps for less than 6 seconds

Operating Current

5 amps (60 Hz), 6.5 amps (50 Hz)

Standby Current

2 amps

INPUT/OUTPUT CONNECTIONS

Three connectors per cabinet
located below logic chassis.

Pin assignment according to
Table 3-1.

Connections according to
Figure 3-2.

SECTION 2

OPERATION



OPERATION

CONTROLS AND INDICATORS

The DSU contains a number of panels and indicators. Figure 2-1 locates the panels and the indicators on a typical cabinet of the DSU. A function description of the controls and indicators follows:

CONTROLS OR INDICATOR

FUNCTION

Operator Panel

START/STOP switch

Switch energizes (when placed in START position) spindle drive motor and begins the First Seek sequence provided the following conditions are met:

1. Disk pack is in place.
2. Front cover is closed.
3. Proper circuit breakers are on.
4. Power is applied through a switch in the control unit to energize the DSU sequence relay.
5. Index Sensor switch is closed.

Switch causes a power off sequence when placed in STOP position.

POWER ON indicator

Lights when switch is on even if one or more of the above conditions is not met. This allows operator to know which units will sequence on when control unit sequence power becomes available.

CLEAR/FAULT switch

Placing the CLEAR/FAULT switch in the CLEAR position clears the FAULT FF in the logic chassis and extinguishes the indicator.

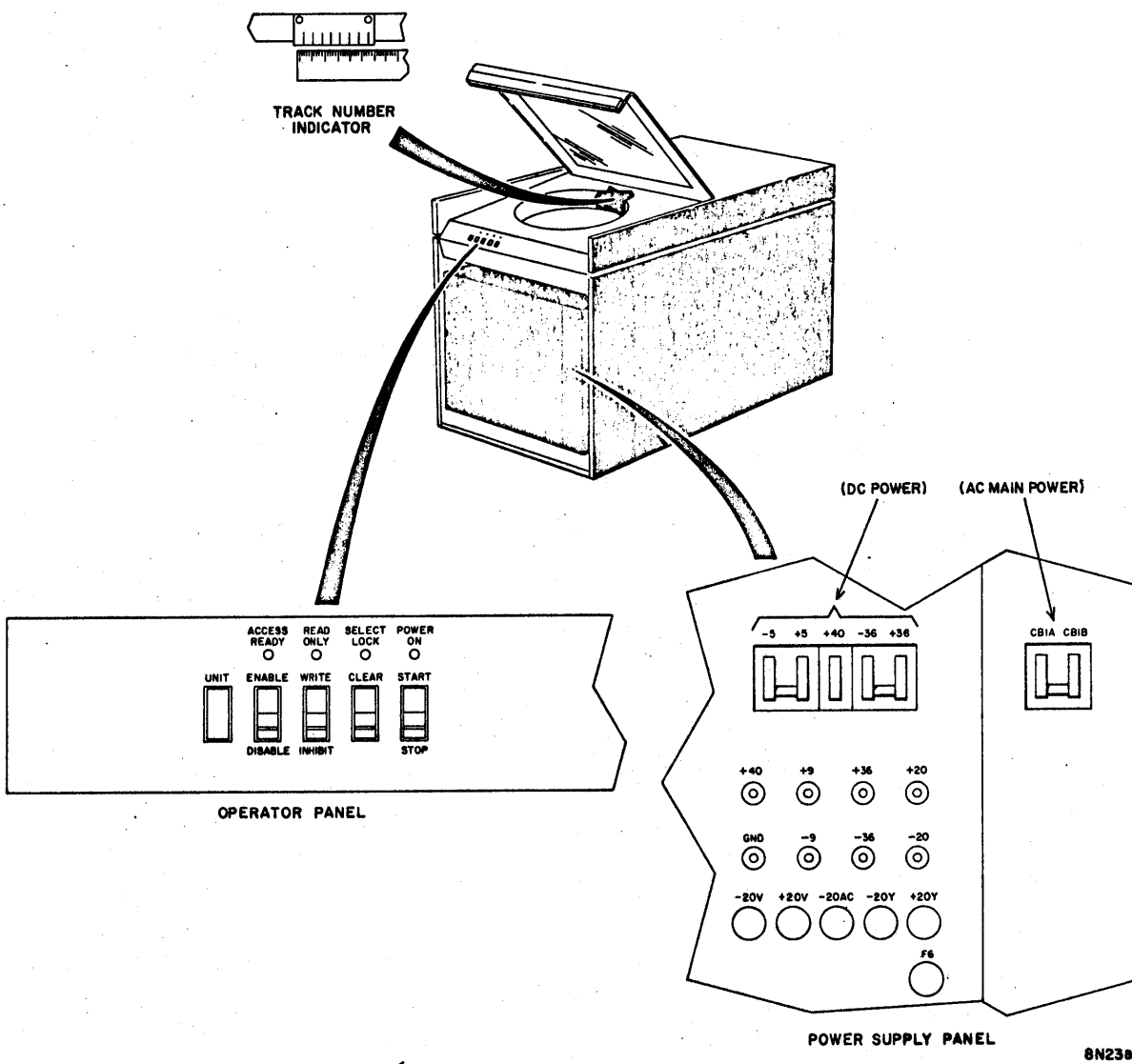

Figure 2-1. Controls and Indicators

OPERATION

CONTROLS AND INDICATORS

The DSU contains a number of panels and indicators. Figure 2-1 locates the panels and the indicators on a typical cabinet of the DSU. A function description of the controls and indicators follows:

CONTROLS OR INDICATOR

FUNCTION

Operator Panel

START/STOP switch

Switch energizes (when placed in START position) spindle drive motor and begins the First Seek sequence provided the following conditions are met:

1. Disk pack is in place.
2. Front cover is closed.
3. Proper circuit breakers are on.
4. Power is applied through a switch in the control unit to energize the DSU sequence relay.
5. Index Sensor switch is closed.

Switch causes a power off sequence when placed in STOP position.

POWER ON indicator

Lights when switch is on even if one or more of the above conditions is not met. This allows operator to know which units will sequence on when control unit sequence power becomes available.

CLEAR/FAULT switch

Placing the CLEAR/FAULT switch in the CLEAR position clears the FAULT FF in the logic chassis and extinguishes the indicator.

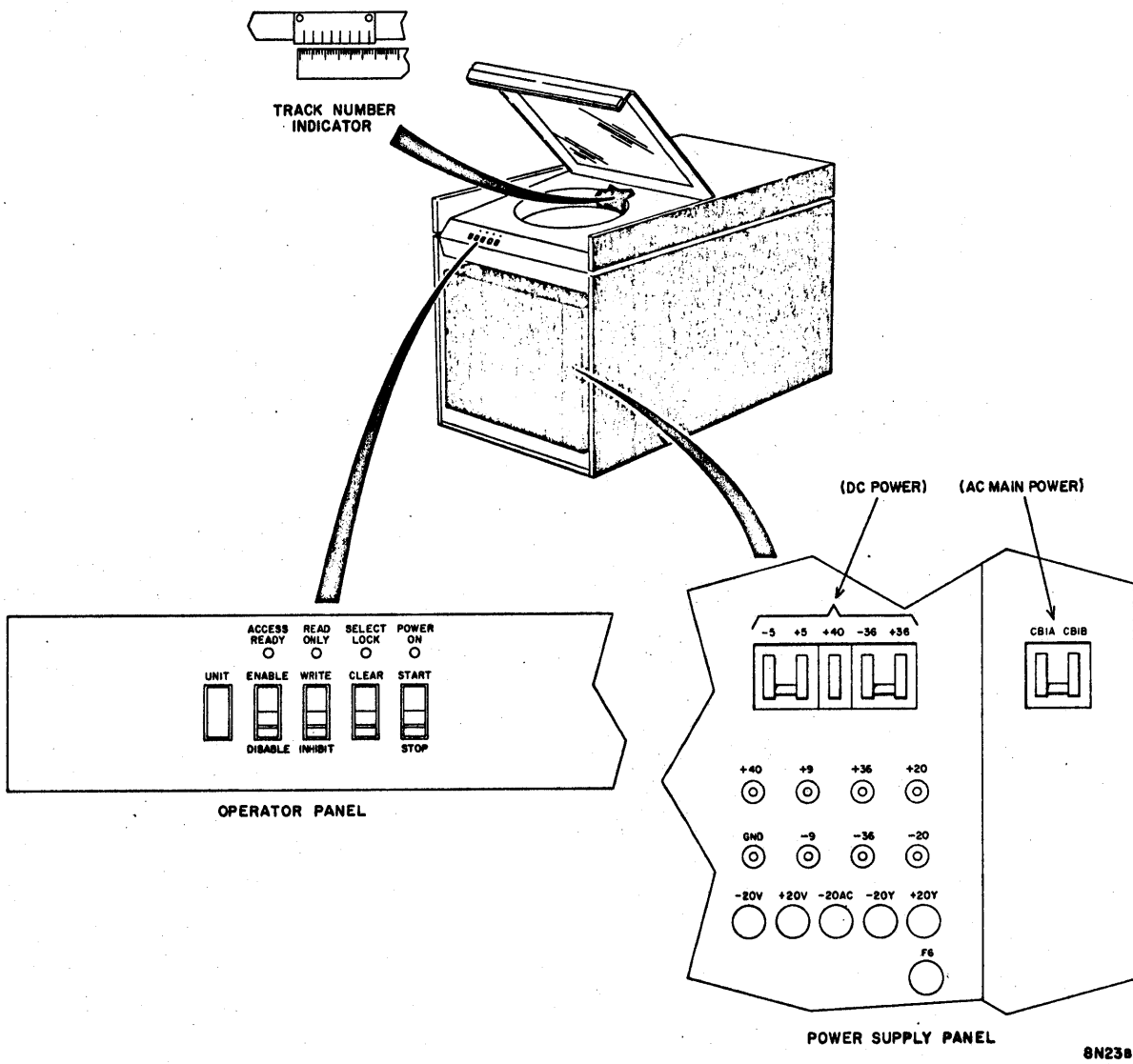

Figure 2-1. Controls and Indicators

CONTROL OR INDICATOR

FUNCTION

ACCESS READY
indicator

Lights when the read/write heads are loaded, and the
ENABLE/DISABLE switch is in the ENABLE position.
A Seek Incomplete signal extinguishes the light.

Physical Unit Number

The DSU is marked with the physical unit number
which may readily be changed to represent any
physical address from 0 to 7.

Power Supply Panel

±5V, ±20V, ±36V, +40V,
and GND test jacks

Afford a point at which dc voltages in the power supply
can be measured.

±5V, ±20V, +40V
circuit breakers

Control application of related dc voltage to the logic
chassis.

F1/1 AMP fuse

Protects the +20V.

F2/1 AMP fuse

Protects the -20 vdc interlock circuit.

F3/1 AMP/BRUSH
MOTOR fuse

Protects the 24 vac brush motor drive circuit.

F4/5 AMP fuse

Protects the +20 vdc logic circuits.

F5/5 AMP fuse

Protects the -20 vdc logic circuits.

F6/1 AMP fuse

Protects the power sequencing circuit.

Deck Assembly

Track number indicator

Vernier scale located near top of carriage beside
read/write heads. Readable only when top cover is
raised. Fixed 0 mark identifies tens group for track.
The coincidental fixed mark identifies the unit.

CONTROL OR INDICATOR

FUNCTION

SELECT LOCK indicator

Lights when one or more of the following unwanted conditions occurs:

1. More than one head is selected.
2. Read and write selects exist at the same time.
3. Read and erase selects exist at the same time.
4. Erase is selected with no write driver.
5. Erase is selected with both write drivers.
6. Either one or both write drivers are on with no erase.
7. Write Gate is on and Write Toggle FF is not toggling.
8. Write or erase is selected without an On Cylinder signal.
9. Low voltage ($\pm 5v$, $\pm 20v$, $\pm 36v$, $+40v$) condition sensed.

WRITE/INHIBIT switch

This is an alternate action switch. Actuating the switch places the DSU write electronics in a disabled state and inhibits any attempted Write operation.

READ ONLY indicator

Illuminates whenever the DSU is in the Write Protected state.

ENABLE/DISABLE switch

This is an alternate action switch. Actuating the switch alternately enables and disables the logical connection between the control unit and the DSU.

The control unit determines the logical state (Enabled or Disabled) by testing the On Line interface signal.

If the switch is actuated when the control unit is performing any operation with the DSU, the logical state of the DSU will not change until the operation is completed.

OPERATING INSTRUCTIONS

DSU POWER APPLICATION

The following procedure prepares the DSU to go on line.

1. Install a disk pack (refer to Disk Pack Installation paragraph).
2. Open the front panel of the DSU cabinet and position the power supply switches as follows:
 - a. +40V circuit breaker to ON
 - b. ±5V circuit breaker to ON
 - c. ±36V circuit breaker to ON
 - d. AC circuit breaker to ON
3. The blower motor will begin to operate.
4. Close cabinet front panel.
5. Set the operator panel START/STOP switch in the START position; the POWER ON indicator lights.
6. When the control unit sequence power becomes available, the First Seek operation begins. ACCESS READY indicator lights when heads have been loaded.
7. The First Seek operation is complete when the heads are returned to track 00. The unit is now ready to receive a Read, Write, or Seek command.

DISK PACK INSTALLATION

Make certain that the disk pack to be installed has been cleared and maintained according to the Preventive Maintenance instructions.

1. Raise the DSU front cover.

NOTE

A spindle lock mechanism is actuated when the front cover is opened. The mechanism holds the spindle stationary while loading the disk pack.

2. Lift the disk pack by the plastic canister handle.

3. Disengage the bottom dust cover from the disk pack using the knob in the center of the cover. Set the cover aside.

CAUTION

Avoid abusive contact between the disk pack and the spindle. During maintenance procedures the read/write heads are sometimes manually positioned. Make certain that the heads are fully retracted.

4. Place the disk pack onto the spindle.

CAUTION

Too rapid rotation of the pack, in the following step, will cause an impact force (at lock in) that may damage the lockshaft.

5. Twist the cannister handle clockwise. Stop twisting the handle only when resistance is met. The disk pack is now locked in place.
6. Lift the cannister clear of the disk pack and set it aside.
7. Close the front cover immediately to prevent the entry of dust and the contamination of the disk surfaces.

DISK PACK REMOVAL

1. Set the operator panel START/STOP switch to STOP.

CAUTION

A spindle lock mechanism is actuated when the front cover is opened. A loud ratcheting noise occurs when the front cover of a spinning disk pack is opened. While this action is not recommended, it will not damage the unit.

2. Check that disk pack rotation has stopped completely.
3. Raise the front cover on the DSU.

CAUTION

During maintenance procedures the read/write heads are sometimes manually positioned. Make certain that the heads are fully retracted.

4. Place the plastic cannister over the mounted disk pack so that the post protruding from the center of the disk pack is received into the cannister handle.
5. Twist the cannister handle counterclockwise until the disk pack is free of the spindle.

CAUTION

Avoid abusive contact between the disk pack and the spindle assembly.

6. Lift the cannister and the disk pack clear of the spindle
7. Close the front cover of the DSU.
8. Place the bottom dust cover in position on the disk pack and tighten it.



SECTION 3

INSTALLATION AND CHECKOUT



INSTALLATION AND CHECKOUT

UNCRATING

During uncrating, care must be taken to ensure that any tools being used do not inflict damage to an assembly. As a cabinet is uncrated, inspect it for possible shipping damage. All claims for this type of damage should be filed promptly with the transporter involved. If a claim is filed for damages, save the original crating materials. Most crating materials will be reuseable if reasonable care is used in uncrating. Uncrate Disk Storage Unit (DSU) as follows:

WARNING

Use care while cutting steel straps as they may whip when cut.

1. On air-shipped units, cut straps securing unit to skid.
2. Remove external packing material.
3. Remove polyethylene dust cover.
4. Open and latch the DSU top cover. Inspect the positioner, carriage assembly, and read/write heads for shipping damage. Remove spindle cover.
5. Remove the tape from the top cover interlock switch.
6. Remove the four rubber shipping blocks located at the corners between the maindeck and frame.

CAUTION

Do not position the carriage manually. Such action could cause the read/write heads to load and be damaged.

7. Remove nylon cord and CAUTION tag from carriage.
8. Open cabinet rear door.
9. Remove two non-metallic straps and wooden block securing logic chassis.
10. Remove tape securing power cable in bottom of cabinet.

11. Open and close the logic chassis assembly. If binding or drag occurs, adjust the upper and lower pivot brackets.
12. Remove access cover from rear of logic chassis. Check that all logic cards are firmly seated in their connectors. Check for loose or broken wires. Install access cover.
13. Open cabinet front door. Remove tape securing primary filter to top of power supply.
14. Slide primary filter into place in base of cabinet.
15. Open power supply access panel and check for any loose or damaged connections.
16. Inspect drive cabling per Figure 3-1 for loose connections.

SPACE ALLOCATION

One DSU cabinet requires a floor area of approximately 2.3 x 3.2 feet. In addition, a 3-foot service access area to the front and rear of the unit should be provided.

LEVELING AND ALIGNING

Position the DSU cabinet to its operational location and level as follows:

1. Lower jack screws in base of cabinet until casters no longer contact floor.
2. Place a spirit level on main deck so ends of level point toward front and rear of deck.
3. Spirit level should indicate that surface is horizontal to within 3 angular degrees. Adjust jack screws until requirement is met.
4. Place spirit level on main deck so ends of level point toward sides of deck. Repeat step 3.
5. Cabinet is level when spirit level (oriented in both directions) indicates main deck horizontal to within 3 angular degrees and each cabinet caster is clear of floor.

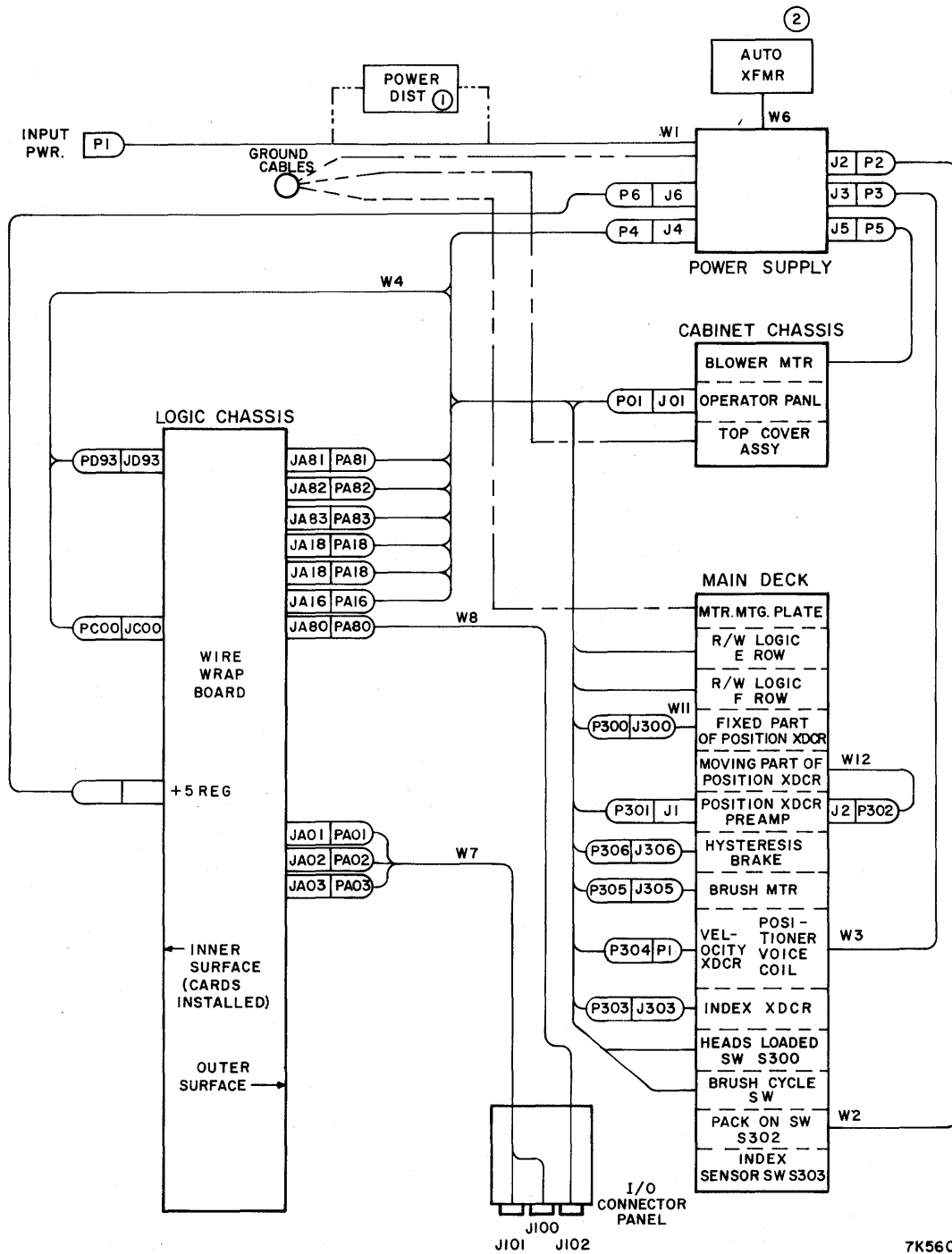

- ① POWER DISTRIBUTION - BR5A5C ONLY.
- ② AUTO TRANSFORMER - BR5A5D/E ONLY.

7K56C

Figure 3-1. Cabinet Cabling Diagram

CABLING AND CONNECTIONS

CABINET INTRACABLING

Inspect the cabling in the cabinet for agreement with Figure 3-1.

INPUT/OUTPUT CABLES

CAUTION

Jack screws on logic chassis connecting cables must be alternately tightened or damage may result.

Refer to Figure 3-2 and install system input/output cables. All input/output cables exit the cabinet near the rear door. Table 3-1 provides information relative to the connector pin/signal assignments for these cables. Terminators must be plugged into the signal-out connector (J101) of the last unit in a daisy chain. The ground bond should be connected to the DSU prior to interconnecting the I/O cables. This provides transient protection for the I/O cards during initial checkout.

TABLE 3-1. INPUT/OUTPUT CONNECTOR PIN ASSIGNMENTS

Cable A (J100 and J101)		Cable B (J102)	
Pins	Function	Pins	Function
70-71	Drive Bus Line 8	1	Spare
14-13	Drive Bus Line 7	2	Spare
12-13	Drive Bus Line 6	3	Spare
11-10	Drive Bus Line 5	4	Spare
8-10	Drive Bus Line 4	5	Write Data
7-5	Drive Bus Line 3	10	DC Ground
4-5	Drive Bus Line 2	11	DC Ground
3-2	Drive Bus Line 1	12	Read Data
1-2	Drive Bus Line 0		

TABLE 3-1. INPUT/OUTPUT CONNECTOR PIN ASSIGNMENTS (Cont'd)

Cable A (J100 and J101)		Cable B (J102)	
Pins	Function	Pins	Function
15-16	Set Difference Tag*	13	Spare
17-16	Set Cylinder Tag	14	Spare
18-20	Set Head	15	Spare
21-20	Control Tag	16	Ground Term for Pin 15**
22-23	Spare	20	Spare
24-23	Read Only	21	Attention
25-26	Spare	22	Selected Module
75-74	Cylinder Address Register 8	23	Module Select
40-41	Cylinder Address Register 7	25	Shield Ground
42-41	Cylinder Address Register 6	26	Ground Term for Pin 21**
43-44	Cylinder Address Register 5	27	Ground Term for Pin 22**
45-44	Cylinder Address Register 4	28	Ground Term for Pin 23**
46-47	Cylinder Address Register 3		
48-47	Cylinder Address Register 2		
49-50	Cylinder Address Register 1		
51-50	Cylinder Address Register 0		
52-53	Drive Ready		
54-53	On Line		
55-56	Index		
57-56	Drive Unsafe		
58-59	Seek Incomplete		
60-59	End of Cylinder		
62-63	Sector Mark		
64-63	Write Current Sensed		
65-66	Heads Extended		
76	Controlled Ground		
77	Sequence Pick		
78	+36 Volt Sequence Power		
73-74	Spare		

*Not used

**Twisted Pair

POWER CABLES

The power cable for the cabinet originates in the cabinet power distribution box located in the rear of the cabinet below the logic chassis. Each power cable should exit the DSU through the floor of the cabinet near the rear door of the cabinet.

GROUND BOND

To minimize the effect of system generated noise, a ground bond (either a tinned copper braid of 7500 circular mils minimum or a copper strap of 5900 square mils minimum) must be connected between each DSU and the controller.

The ground bond is connected to the GND terminal on the floor of the frame located in the rear of the cabinet below the logic chassis.

The ground bonding scheme may be daisy chained or individually connected between each DSU and controller.

CABINET ACCESSORIES

Carefully insert appropriate Logic Number plugs into holes to left of operator panel switches and push plugs into receptacles.

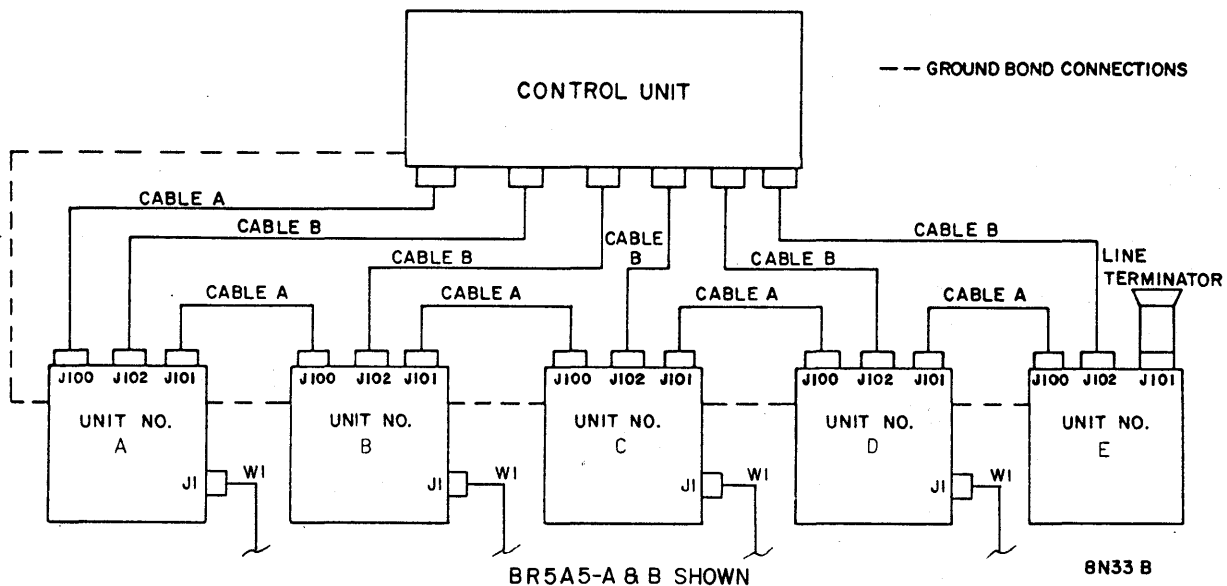

Figure 3-2. System Cabling

INPUT POWER REQUIREMENTS

NOTE

Although three-phase power is specified, power for this device is obtained between one phase and neutral. Units leave the factory wired for 208v, 60Hz or 220v, 50Hz input.

The BR5A5D/E is capable of operating with six input power options. Make certain that the black and orange leadwires of cable W6 are connected to the autotransformer in accordance with the input power source to be used as follows:

<u>Input power to be used</u>	<u>Orange wire to autotransformer tap</u>	<u>Black wire to autotransformer tap</u>
200-volt	2	1
208-volt	3	1
220-volt	5	1
230-volt	6	1
240-volt	7	1
250-volt	8	1

The maximum current consumption with this input voltage is as follows:

Operating current (disk pack turning, steady-state)	5 amps (60Hz), 6.5 amps (50Hz)
Standby current	2 amps
Surge current	22 amps drawn by spindle motor during start. (Decreases to operational level as motor approaches operating speed.)

ENVIRONMENT

Operation and storage environments of the DSU are as follows:

Operating status	60 to 90°F (12°F/hr maximum fluctuation) 10 to 80% relative humidity (providing there is no condensation)
Non-Operating status	-30 to 150°F 5 to 95% relative humidity (providing there is no condensation)

INITIAL CHECKOUT AND STARTUP PROCEDURE

This procedure should be used to make the first power application to the DSU. The procedure assumes that the preceding procedures and requirements of this section have been performed and satisfied.

1. Open cabinet rear door. Swing logic chassis out and remove inner access cover. Check that all logic chassis cards are firmly seated in their connectors and all W/W connections are secure. Install access cover.
2. Open top cover.
3. Check that the four logic cards adjacent to shroud are seated securely in their connectors and plugs are tight.
4. Grasp and turn the spindle. The spindle should rotate with little resistance.

CAUTION

Bearing damage may occur if alcohol runs into spindle

5. Wipe spindle surface clean with alcohol-dampened gauze.

CAUTION

Do not position the carriage manually; such action could cause the read/write heads to load and be damaged.

6. Inspect and clean read/write heads (see Preventive Maintenance Index, Section 6).
7. Make certain that index transducer and pack cleaning brushes are rotated back from shroud openings.
8. Close top cover.
9. Install a disk pack (see Section 2).
10. Inspect and clean disk pack (see Preventive Maintenance Index, Section 6).
11. Remove disk pack from spindle (see Section 2).
12. Use a vacuum cleaner to remove any dust or dirt from interior of shroud and cabinet.
13. Install disk pack.
14. Set AC circuit breaker to OFF.
15. Make certain that cabinet power cable is connected to correct external ac power source.
16. If external ac power to DSU is protected by circuit breaker, set circuit breaker to ON.

17. Set power supply panel switches as follows:
 - a. +40V circuit breaker to OFF
 - b. +5V circuit breaker to OFF
 - c. +36V circuit breaker to OFF
 - d. AC circuit breaker to OFF
18. Set power supply +40V, +5V, +20V, +36V, and AC circuit breakers to On.
19. Set START/STOP switch to START. POWER ON indicator will light.
20. Make sequence power available from control unit.

NOTE

When more than one DSU is being powered up, power is sequenced to the next deck in line when the spindle of the preceding unit reaches the correct speed. The following events do not occur simultaneously in each DSU to be powered up.

21. Spindle drive motor and disk cleaner (brush) motor start.
22. When disk pack reaches operational speed, sequence power is passed to the next DSU (if any) to be powered up.

NOTE

Further activity ceases until brush motor finishes driving the cleaning brushes over disk pack surfaces.

23. When brushes are returned to a position clear of disk pack, the positioner drives the carriage forward to load read/write heads.
24. Perform Head/Arm Adjustment procedure (see Corrective Maintenance).
25. Perform Index to Burst Check and Adjustment procedure (see Corrective Maintenance).

26. To stop spindle motor, set operator panel START/STOP switch to STOP (indicator will extinguish). To remove power to DSU, set AC circuit breaker to OFF.
27. Allow disk pack rotation to stop before opening front cover.

TABLE 3-2. SWITCH SETTINGS FOR LOGIC CARD AT A16

SWITCH AT A16-D3			
		(DEPRESSED) ON	<input type="checkbox"/> <input type="checkbox"/> <input type="checkbox"/> <input type="checkbox"/> <input type="checkbox"/> <input type="checkbox"/> <input type="checkbox"/> <input type="checkbox"/>
		(DEPRESSED) OFF	<input type="checkbox"/> <input type="checkbox"/> <input type="checkbox"/> <input type="checkbox"/> <input type="checkbox"/> <input type="checkbox"/> <input type="checkbox"/> <input type="checkbox"/>
Switch Position		On (Depressed)	SW #
1		*55 USEC INDEX	44
2	Note 2	*55 USEC SECTORS	42
3	Note 2	*SECTORS ENABLE	36
4	Note 2	SECTORS ÷ 2 ENABLE	37
5	Note 2	SECTORS ÷ 4 ENABLE	38
6	Note 3	*COINCIDENT INDEX ENABLE	39
7	Note 3	SINGLE INDEX ENABLE	41
8	Note 3	STAGGERED INDEX ENABLE	40
<p>Off (Depressed)</p> <p>2.5</p> <p>2.5 USEC SECTORS</p> <p>SECTORS DISABLE</p> <p>*SECTORS ÷ 2 DISABLE</p> <p>*SECTORS ÷ 4 DISABLE</p> <p>COINCIDENT INDEX DISABLE</p> <p>*SINGLE INDEX DISABLE</p> <p>*STAGGERED INDEX DISABLE</p>			
<p>NOTES:</p> <p>1. Ensure that all switches are completely open or closed and properly seated in their respective positions.</p> <p>2. Select one on position only from 3, 4, or 5.</p> <p>3. Select one on position only from 6, 7, or 8.</p> <p>4. The asterisked switch settings indicate those that make the EKXV functionally equivalent to the 3KXV.</p>			

SECTION 4

THEORY OF OPERATION

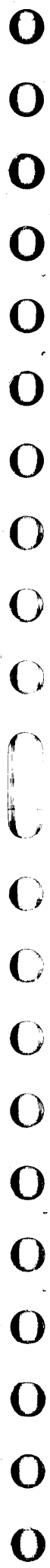

THEORY OF OPERATION

Theory of operation for the DSU is divided into three parts. The first part considers the DSU in terms of the functions it performs and the signals exchanged with the controller. The second part relates the major assemblies of the DSU to the previously discussed functions. The last part deals with the disk pack which is physically not a part of the DSU, but figures functionally in all DSU operations.

FUNCTIONS

Overall capabilities of the DSU are best described by examining the functional blocks of activity performed by a DSU. The functions are as follows:

First Seek

Direct (Forward or Reverse) Seek (details servo operation)

Return to Zero Seek (RTZS)

Read/Write/Erase

Each of these functions is further described by flow charts and timing diagrams in Section 5 of this manual set, Publication No. 83302400.

The above functions are performed by each DSU. Normal operation is such that a controller will generally be directing the functional activities of more than one unit. Figure 4-1 shows the method of selecting and gating input/output data to a particular unit. Figure 4-2 details the sequence of events that establishes the link and gating. The signals that are then exchanged are described in Table 4-1 and are shown relative to a point of origin on Figure 4-3.

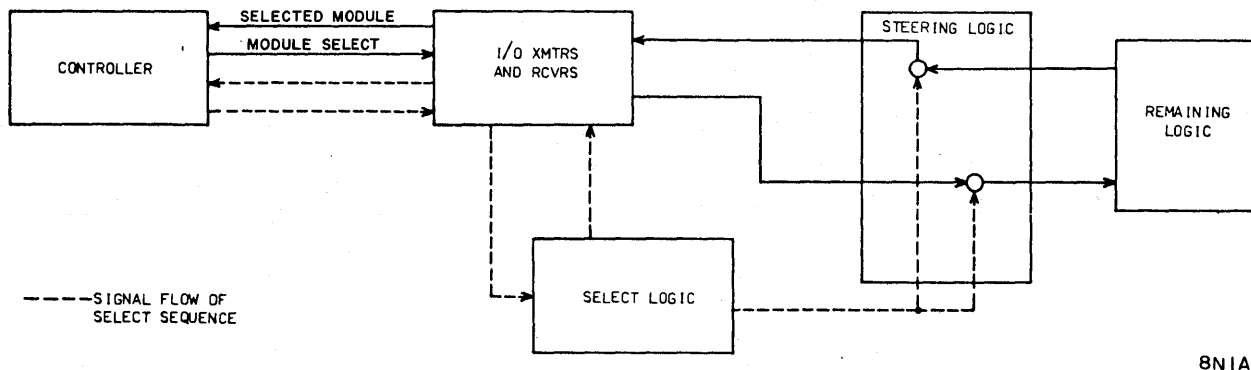

8N1A

Figure 4-1. Input/Output Signal Gating

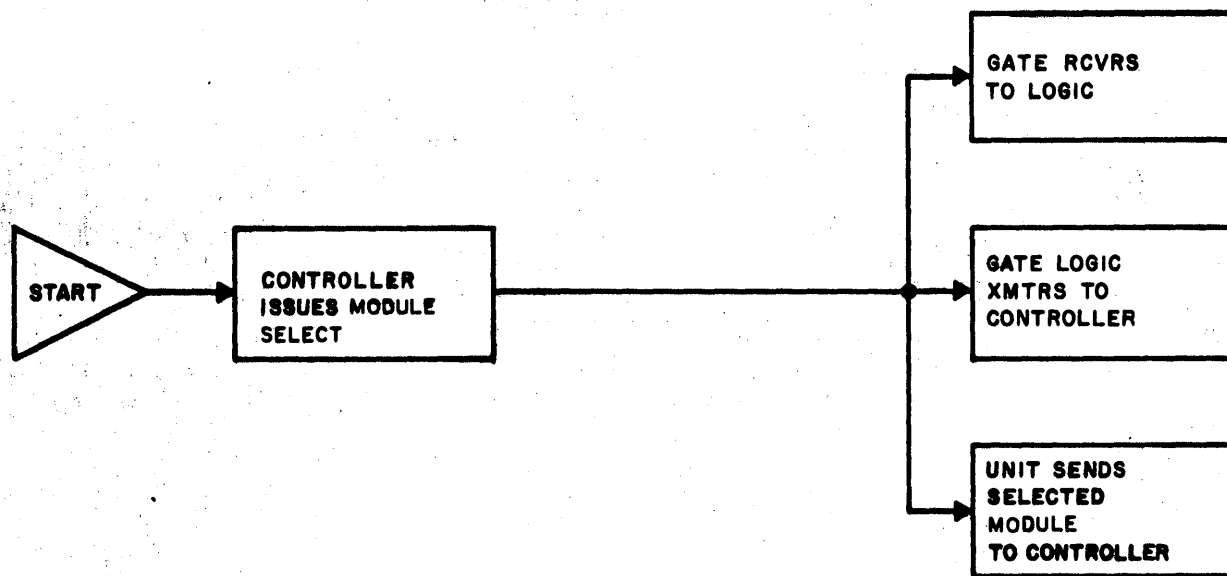

8N2B

Figure 4-2. Select Sequence

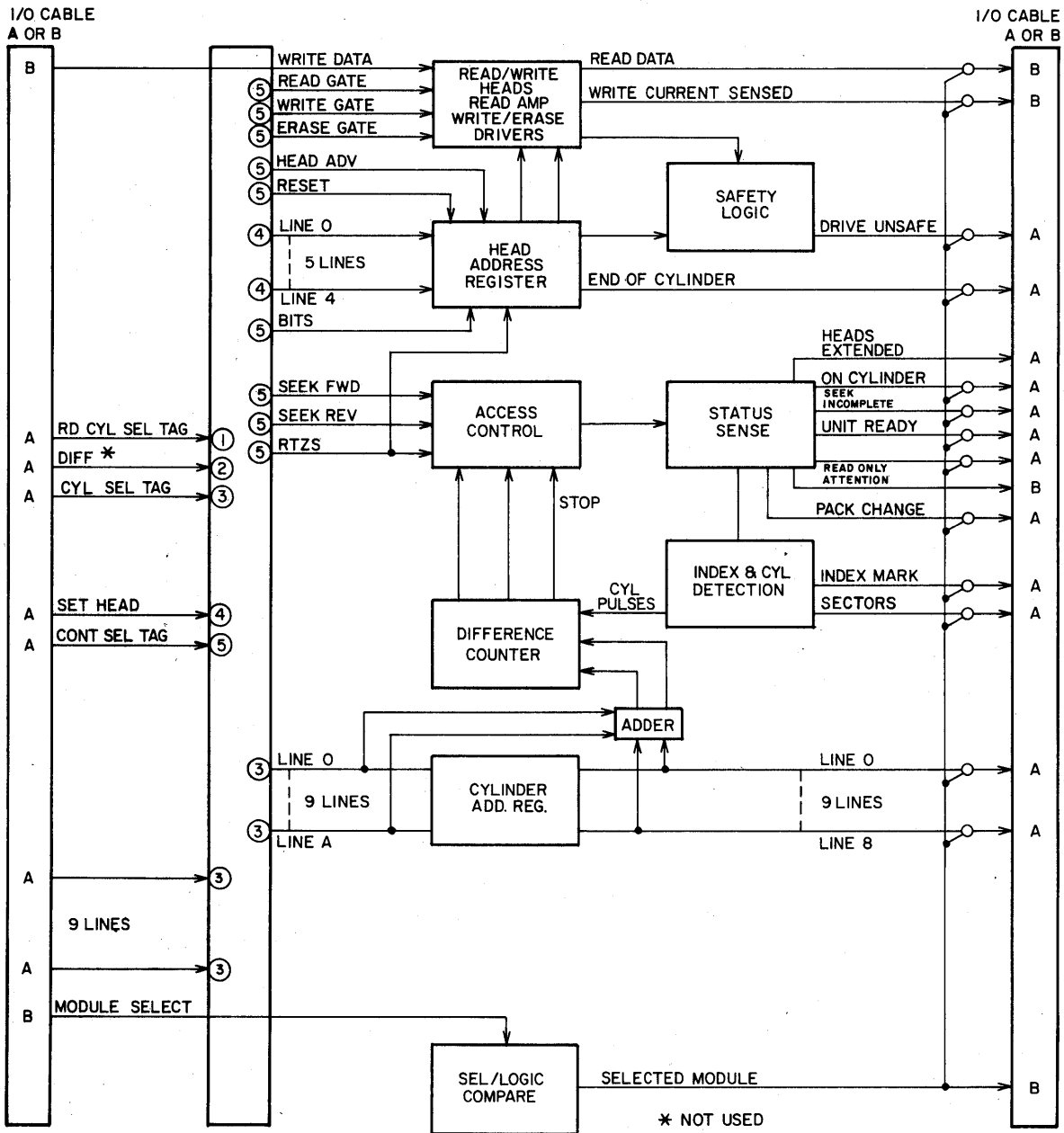

8N 35 A

Figure 4-3. Block Diagram

TABLE 4-1. INPUT/OUTPUT LINES

Signal		Function	
Bit Lines Address and Control		Information carried by the bit lines is coupled by three select (tag) signals. The influencing tag signal must be known before information on the bit lines can be interpreted. The three tag signals are defined below under Input Lines. The information coupled by each tag signal is as follows:	
Address/ Control bus	Cylinder Select	Set Head	Control Tag
Bit 0	128	Not Used	Write Gate - A "1" input on this line enables the write drivers.
Bit 1	64	Not Used	Read Gate - A "1" input on this line clears the seek complete latch for the selected logical unit.
Bit 2	32	Not Used	Seek - A "1" input on this line initiates carriage movement.
Bit 3	16	16	Reset - A "1" input on this line sets the Head Address register to zero.
Bit 4	8	8	Erase Gate - A "1" input on this line enables the erase driver to pass current through the head erase coil.
Bit 5	4	HD 4	Select Head

TABLE 4-1. INPUT/OUTPUT LINES (Cont'd)

Signal		Function	
Address/ Control bus	Cylinder Select	Head Select	Control Tag
Bit 6	2	HD 2	Return to Zero - A "1" input on this line initiates carriage movement to cylinder 00, inhibits Head Select, clears the Seek Incomplete FF, Cylinder Address registers and clears head register.
Bit 7	1	HD 1	Head Advance - A "1" input on this line increments the Head Address register so that the next head in order can be selected.
Bit 8	256	Not Used	Not Used
<u>Signal</u>		<u>Function</u>	
<u>Input Lines</u>			
Set Difference		Not used by drive.	
Set Cylinder		A "1" input on this line indicates that the address and control lines contain the control unit's current cylinder request.	
Set Head		A "1" input on this line indicates that the address and control lines contain the head select information.	

TABLE 4-1. INPUT/OUTPUTS LINES (Cont'd)

Signal	Function
Control Tag	A "1" input on this line indicates that the address and control lines contain information.
Module Select	If the unit is ready, it returns a Selected Drive Ready. If not ready, the unit returns a "0" on the Selected On Line. Module Select must remain for the duration of continuous communication with the selected DSU.
Write Data	Carries information to be written from the control unit to the selected unit.
<u>Output Lines</u>	
Selected Module	A "1" output on this line indicates this unit is selected. The Enable/Disable switch is in the Enable position, and there is no Drive Unsafe condition.
Read Data	Carries digital information read from a disk to the control unit.
Selected Drive Ready	Indicates that the positioning mechanism of the selected unit has stopped and the read/write heads have reached the address cylinder.
Selected Seek Incomplete	A "1" output indicates that the selected unit was unable to complete a seek operation within 400 ms or has travelled outside the limits. The Selected Seek Incomplete signal line is inhibited until On Cylinder status is reached. A Return to Zero Seek command, sent to the unit indicating the seek error, clears the Selected Seek Incomplete condition and returns the heads to cylinder 00.
Selected Index	Provides a track reference mark from the selected unit to the control unit. This mark occurs once for each revolution of the disk pack.

TABLE 4-1. INPUT/OUTPUT LINES (Cont'd)

Signal	Function
Selected Drive Unsafe	<p>A "1" output indicates that the selected deck has one or more fault conditions. Write and erase currents are inhibited by the presence of any of the following conditions:</p> <ol style="list-style-type: none"> 1. More than one head selected. 2. Read and write gates up at the same time. 3. Read and erase gates up at the same time. 4. Erase and no write driver on. 5. Erase and both write drivers on. 6. One or both write drivers on and no erase driver on. 7. Write or erase gate on and not On Cylinder. 8. Low voltage situation that could cause a loss in control of write and erase currents. 9. Write gate on and write toggle not toggling. <p>An 85-μsec delay starts when either write gate or erase gate drop. If fault condition 1, 4, 5, or 6 occurs during the delay but does not exit after the delay times out, the Fault FF is not set and the occurrence is not detected. At any other time, conditions 1, 4, 5, or 6 are detected, and the Fault FF sets within 7.5 μsec.</p>
Selected On Line	<p>This signal is a response to the receipt of a Unit Select. A "1" output is present if the disk pack is installed, spindle motor is up to speed, heads are loaded, ENABLE/DISABLE switch in Enable position, and no Drive Unsafe condition exists.</p>
Attention	<p>A "1" output on this line is an interrupt to the controller indicating the drive is on cylinder and is not reading.</p>

TABLE 4-1. INPUT/OUTPUT LINES (Cont'd)

Signal	Function
Selected end of Cylinder	Indicates that the head register has been incremented to a count that exceeds 19, signifying an illegal head count. Signal may be cleared by a Return to Zero Seek, a Reset Head Register command, or by performing a Head Select command with a legal head count.
Selected Read Only	A "1" output indicates that the READ ONLY switch is in the Read Only position and Write and Erase commands will be ignored.
Selected Write Current Sensed	A "1" output indicates that normal write current is present.
Heads Extended	The drive presents this line with either a "ground" indicating the heads are extended or with an "open" indicating the heads are retracted. The line will be at ground until all drives connected to the controller have retracted their heads. The controller does not drop AC and DC power until this line indicates an open circuit.
Selected Sector	Provides a sector reference mark from the DSU to the controller, This mark occurs each time a sector mark on the disk pack is crossed.

FIRST SEEK

This function involves the activities that a unit must perform before it can effectively respond to a Read, a Write, or a Seek command from the controller. This function consists mainly of power supply relay sequencing and status checking by the units logic. As a result, no actual selection of the unit is required and very little DSU/controller signal

exchange occurs. Successful progression of the function assumes that power supply circuit breakers for the unit are on, power supply fuses are operational, related filter box panel circuit breaker is on, START indicators for unit are lighted, disk pack is installed on spindle of unit, cabinet covers (top and front) are closed, and index sensor is in position.

Initiation of the function occurs when the controller makes sequence power available to the DSU power supply. Sequence power causes the power supply relay K1 to energize and the power supply performs a Power-On sequence (refer to Power Supply under Assemblies in this section for a detailed description).

Power is applied to the brush and spindle drive motors during the Power-On sequence. Application of power to the brush motor starts a 20-second (approximately) disk cleaning cycle. When the disk pack speed reaches 2000 rpm, the power supply relay K5 energizes to provide sequence power to the next unit in line.

Transfer of the brush switch contacts at the end of the brush cycle sets the Load FF, Seek FF, and Forward Latch (FF), and clears the First Seek FF. It also causes the difference counter to be set to 495, and since the counter works with complements, this value amounts to a request for a 16-cylinder seek. (Changing of the counter content will be inhibited until after the forward end of travel limit is sensed.) The net result is that the positioner performs a forward 16-ips access that mechanically loads the read/write heads. The carriage then continues forward until the first even cylinder pulse (cylinder 406) occurs after the forward end of travel limit (located between cylinders 404 and 405) is sensed. This combination of occurrences causes the carriage to begin reversing, and causes the content of the difference counter to change to 105 (complement of 406). As the carriage is reversing, only odd cylinder pulses are gated to increment (to 106) the difference counter, and as long as the forward end of travel limit is up, each even track pulse triggers a strobe that resets the counter to 105. The result is that as the reverse moving carriage moves back inside of the forward travel limit, the difference counter

0

0

0

content becomes 107 (complement of 404) as cylinder 404 is crossed. With the difference counter calling for a 404-cylinder seek, the positioner responds by performing a reverse seek to cylinder 00 in the following sequence:

1. Accelerates to 50 ips and proceeds until 64 cylinders remain.
2. Decelerates under control of the desired velocity generator from 50 ips to 25 ips which is maintained until 32 cylinders remain.
3. Decelerates under control of the digital to analog converter during the next 31 cylinders.
4. Moves the last cylinder and stops under control of the fine position analog signal.

Refer to the Direct Seek paragraph for a detailed description of servo circuit operation.

The unit sends a Selected Drive Ready (and Seek Complete) signal to the controller 1.75 ms after reaching cylinder 00. (A Selected Seek Incomplete signal is also sent if a 400 ms delay, starting when the seek motion first began, has timed out.)

The deck is now ready to perform a Read, Write, or Seek (Direct or RTZS) operation. Such an operation must be preceded by the selecting sequence (Figures 4-1 and 4-2).

DIRECT (FORWARD/REVERSE) SEEK

The Direct Seek function involves those operations that must be performed to move the read/write heads from their current track or cylinder location to the one specified by the controller. This function must be preceded by the selecting sequence (Figures 4-1 and 4-2) unless the unit is already selected. Assume that the desired unit just completed a First Seek and is awaiting further instruction at cylinder 00. Assume further that the controller wishes to do a Read or a Write operation at cylinder 176. When the controller determines that the deck is selected and ready, it issues a Set Cylinder signal. This signal gates the content of the DSU's Address register (00) to the DSU's

0

adder (content of the register always reset to 00 during a First Seek or RTZS). The adder then calculates the difference between the unit's current and desired location and sends a Difference Select that gates the complement of the seek length (complement of 176 = 335) into the difference counter of the unit. The same Set Cylinder signal is delayed 25 μ s and then loads the Cylinder Address Register with the desired cylinder (176) which is present at the I/O for controller use. Next the controller sends a Head Select signal that gates the number corresponding to the desired read/write head into the Head register. The last address and control exchange involved the Control Select signal that gates a "1" to the unit on bit 2 (Seek) of the bit lines.

0

0

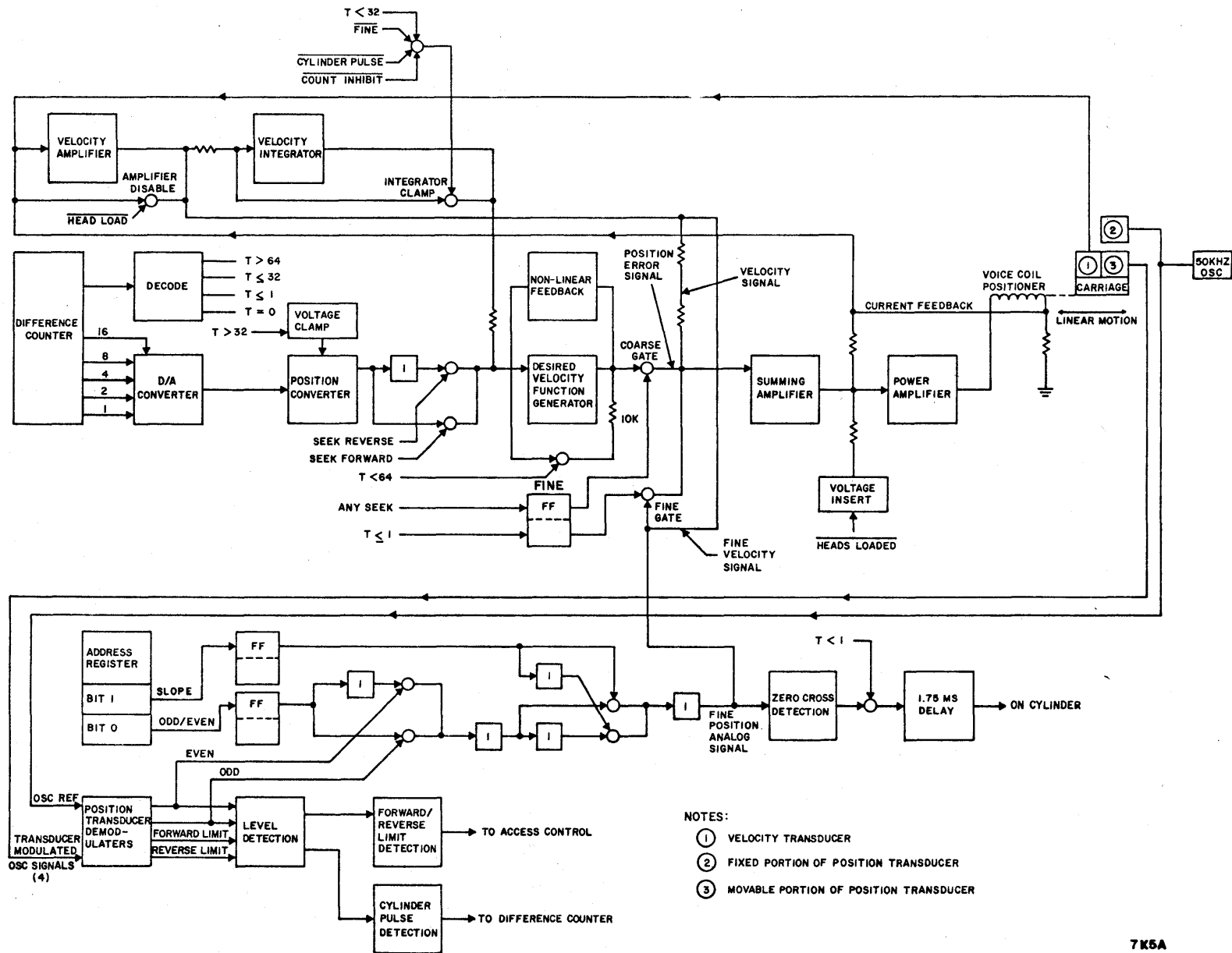

NOTES:

- ① VELOCITY TRANSDUCER
- ② FIXED PORTION OF POSITION TRANSDUCER
- ③ MOVABLE PORTION OF POSITION TRANSDUCER

Figure 4-4. Servo Circuit Block Diagram

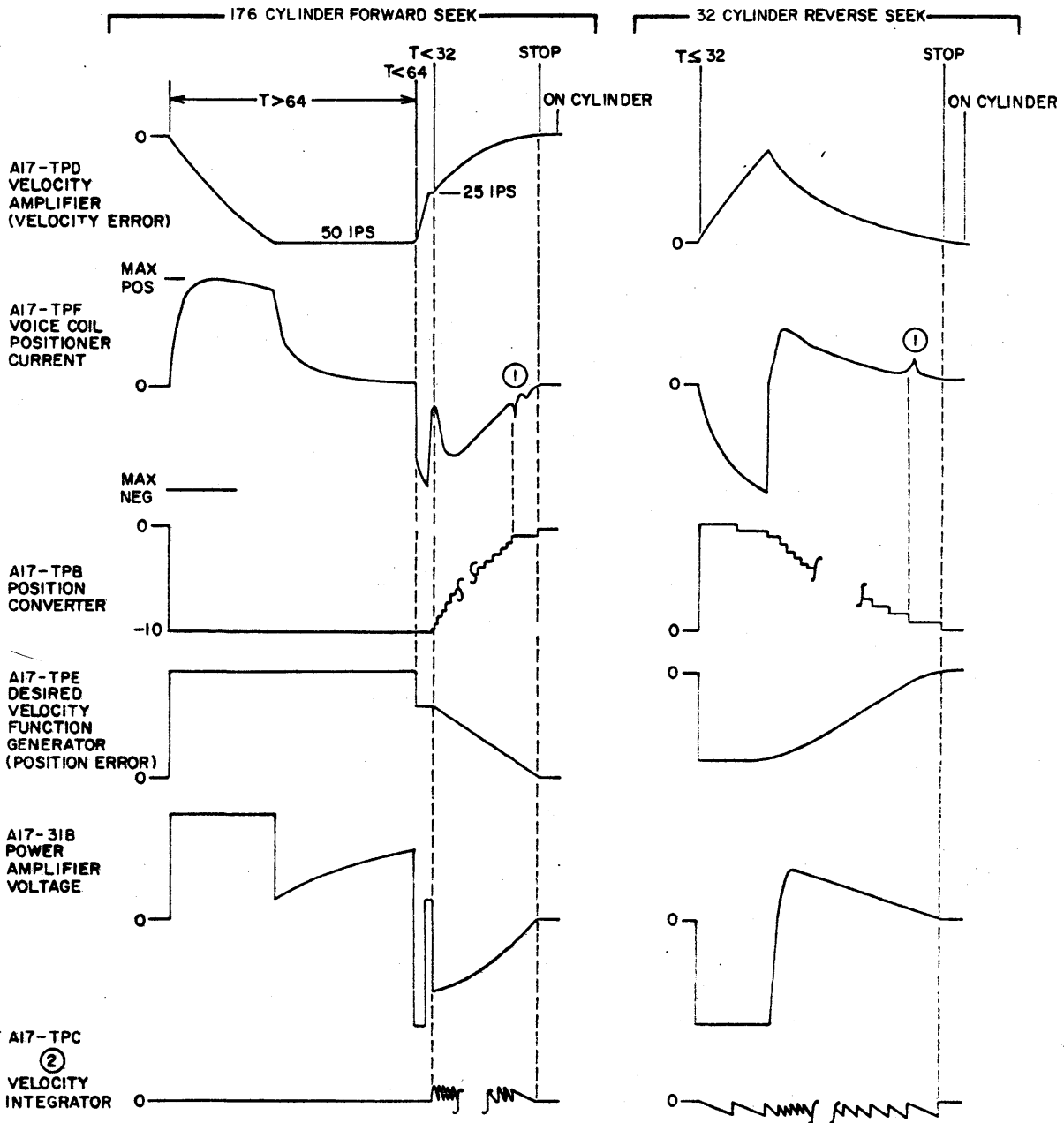

NOTE:

- ① CHANGE IN GAIN OCCURRING WHEN SEEK CONTROL SWITCHES FROM COARSE POSITION TO FINE POSITION ANALOG SIGNAL.
- ② ADDS PULSES AT INPUT TO DESIRED VELOCITY FUNCTION GENERATOR IN ORDER TO FILL IN (SMOOTH OUT) STEPPED SIGNAL FROM POSITION CONVERTER.

8N34A

Figure 4-5. Typical Servo Signal Relationships

NOTE

Refer to Figures 4-4 and 4-5 and Servo Circuit Functions during the following description. Servo circuit operation hinges generally on the relationship of the position error signal to the velocity signal at the summing amplifier input. When position error exceeds velocity, acceleration occurs; when velocity exceeds position error, deceleration occurs. When position error amplitude is static and velocity equals it, a velocity plateau occurs.

The Seek Forward gates the output of the position converter (position error signal) into the desired velocity function generator. (A Seek Reverse would have gated an inverted position error signal.) Since the seek length is greater than 32 cylinders, the position converter output is clamped at a fixed voltage. Receipt of the Seek Forward signal also caused an Any Seek signal to occur. Any Seek gates the output of the desired velocity function generator (coarse position error) to the summing amplifier. Since the carriage is stationary, no velocity signal exists to balance the position error, and forward motion of the carriage begins.

With the position error signal clamped at maximum, the power amplifier output (and voice coil positioner current) will be maximum, and the carriage will continue to accelerate.

As the carriage moves forward, outputs from the position transducer on the carriage are processed to derive a cylinder pulse as each cylinder is crossed. Each pulse increases the content of the difference counter by one. When acceleration has increased to the point where the velocity amplifier signal and the position error signal cancel each other, the summing amplifier control signal drops off. During this phase, the carriage coasts along the 50 ips plateau with the power amplifier providing only enough output voltage to compensate for the back emf of the moving voice coil position.

SERVO CIRCUIT FUNCTIONS

<u>Circuit Element</u>	<u>Function</u>
Difference Counter	Holds the complemented count of cylinders yet to be crossed before reaching the desired cylinder.

<u>Circuit Element</u>	<u>Function</u>
	An associated decoding network provides outputs representative of the current general content of the counter.
Digital to Analog Converter	Monitors the five lowest order bits of difference counter to provide an analog indication of position error during the last 32 cylinders (except last cylinder) of all seek operations.
Position Converter	Provides coarse position error signal, the amplitude of which relates to the proximity of the desired cylinder. Amplitude is clamped to highest point while cylinders remaining are greater than 32. Amplitude decreases in discrete steps (controlled by D/A Converter) as last 32 cylinders of a seek are crossed.
Desired Velocity Function Generator	Processes position error signal at gain levels that vary as position error decreases. When cylinders remaining become less than 64, a low resistance (10K) negative feedback path is enabled that decreases generator gain. The parallel nonlinear feedback circuit allows a gain of unit to exist until the position error falls within ± 2 volt band to either side of zero at which time the generator gain begins increasing as position error decreases. This increase prevents loss of control during the critical deceleration portion of the seek and is essential to minimize overshoot and settleout problems.

<u>Circuit Element</u>	<u>Function</u>
Summing Amplifier	Generates a control signal to drive the power amplifier. Control signal based on algebraic summation of position error and velocity signals. When position error exceeds velocity amplifier signal, control signal causes power amplifier to accelerate carriage. When velocity signal exceeds position error, carriage decelerates.
Power Amplifier	Responds to summing amplifier derived control signal to drive carriage mounted voice coil positioner. Current feedback is used to stabilize the gain of the power amplifier. Associated voltage insert forces a retract signal to be applied when heads are unloaded. This retract holds carriage retracted prior to being overridden by a forward drive at the beginning of a First Seek (load heads) sequence.
Velocity Amplifier	Amplifies signal of carriage mounted linear velocity transducer to provide an indication of velocity to the servo circuit. Also receives a negative feedback from positioner which acts to cancel current coupling that occurs from the velocity transducer location within the magnetic field; field created when current is applied to the voice coil positioner. The associated amplifier disable forces amplifier gain to zero during a Power Off sequence (unload heads). This is required so that coupling between the positioner field and the velocity transducer does not cause oscillation during movement to the retracted position.

<u>Circuit Element</u>	<u>Function</u>
Velocity Integrator	Provides an integrated representation of velocity between each of the last 16 cylinder pulses of a seek. Integrator is clamped off at all other times. Integrator output is applied to input of desired velocity function generator between each cylinder pulse to fill in or smooth out the stepped signal of the D/A converter (received via the position converter). Related integrator clamp forces integrator gain to zero at all times except as explained previously.
50 KHz Oscillator	Applies its signal to fixed portion of position transducer and position transducer demodulators (refer to Transducers paragraph under Assemblies in this section).
Position transducer demodulators	Compare modulated signals from movable portion of position transducer with 50 KHz oscillator reference signal. Output is a demodulated positive signal when input is in phase with oscillator reference. Output is a demodulated negative signal while input is out of phase with oscillator reference (refer to Transducers paragraph under Assemblies in this section).
Level Detection	Detects and switches in response to amplitude variations to either side of zero volts by the demodulated position transducer signals.
Cylinder Pulse and Forward/Reverse Limit Detection	Observe switch level detection circuit to derive pulses representing cylinders being crossed or carriage motion limits being passed. Cylinder pulses increment difference counter and gate velocity integrator.

<u>Circuit Element</u>	<u>Function</u>
Bit 7 Address Register	Used to select proper demodulated position transducer signal for use as fine position analog signal (signal controlling servo loop as last cylinder is approached and carriage is stopped). If bit 7 is set, the seek destination is an odd numbered cylinder and the odd cylinder signal will be gated for use in stopping the carriage. If bit 7 is not set, an even cylinder is identified and will be used. Register bit content is placed in a Storage FF which performs actual gating.
Bit 6 Address Register	The demodulated position transducer signal is used as the fine position analog signal (signal used to move carriage last cylinder and stop). Bit 6 of the Address register gates this signal so that its slope is always negative (approaching zero volts from positive) during the last track of forward seeks. Gating occurs so that the signal slope is always positive during a reverse seek. In this way, the fine position signal will always be of a polarity that is opposite that of the velocity signal (a mandatory relationship at the summing amplifier input if the servo is to function correctly). Register bit content is placed in a Storage FF which performs actual gating.
Zero Crossing Detector	Detects fine position analog signal transition to zero volts (carriage stopped). Detected zero crossing is delayed (allows any carriage vibration to settle out) prior to being issued as On Cylinder.

When the cylinders remaining in the seek become less than 64 (difference counter decoding), the gain of the desired velocity function generator is reduced. This causes a situation wherein the velocity signal exceeds the position error signal. The servo immediately decelerates the carriage until the two signals again cancel each other. This results in a plateau (relatively short) at approximately 25 ips. The carriage proceeds on the plateau until the difference counter decoding indicates less than 32 cylinders to go to the desired cylinder. At this point the position converter voltage clamp is disabled, and for the remainder of the seek (except the last cylinder) the servo position error is derived from the D/A converter. As each cylinder is crossed, the D/A converter output drops by a precise and linear amount. So that the position error provided at the desired velocity function generator input is not stepped, the integrator clamp gates the velocity integrator on between each cylinder pulse. The resulting integrator sawtooth output is added to the D/A converter output and fills in the area between the leading edges of each step. As the position error decreases, the summing amplifier control signal decelerates the carriage to keep the velocity signal/position error signal difference to zero.

When the difference counter indicates one cylinder to go to the desired destination, the coarse gate is disabled and the fine gate is enabled. The summing amplifier will now receive the position error from a new source and a second velocity signal of higher gain is gated in.

Since the desired destination is cylinder 176, both bit 7 and bit 6 of the Address register are "0". Bit 7 gates out the current even demodulated position transducer signal, the slope of which is positive. However, gating by bit 6 causes inversions that result in a fine position analog signal with a negative slope. As the carriage approaches cylinder 176, the signal from the position transducer (fine position analog signal) approaches zero volts (Figure 4-6). The summing amplifier responds to this decrease in amplitude by decelerating the carriage so that the sum of the velocity signals always just cancels the fine position analog signal. At cylinder 176 both velocity and position error equal zero, and all motion stops with the servo circuit at null. Only a position error will cause additional motion. When the fine position analog signal reached approximately zero volts, a delay of 1.75 ms started. The On Cylinder (and Seek Complete) signal occurs when the delay times out. (A 400 ms delay was started by the Any Seek signal. If this delay had timed out before the occurrence of On Cylinder, a Seek Error signal would have been sent to the

controller.) The unit is now ready to perform a Read, a Write or a Seek operation.

RETURN TO ZERO SEEK (RTZS)

The RTZS function allows a controller to return the read/write heads to cylinder 00 when a Seek Error signal occurs. This function must be preceded by the selecting sequence (Figures 4-1 and 4-2) unless the unit is already selected. The controller responds to a Seek Error signal from a unit by sending a Control Select tag that gates a "1" on bit 6 (RTZS pulse) of the bit lines to the afflicted unit.

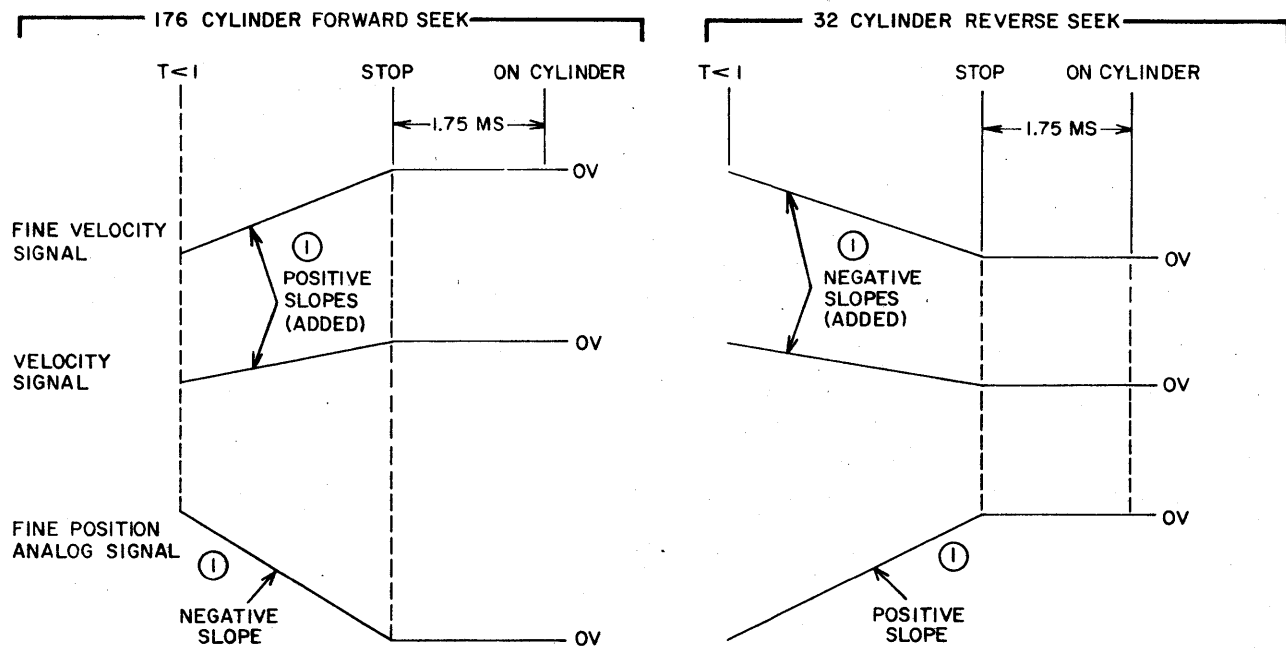

NOTE:

- ① SUMMING AMPLIFIER RESPONDS TO DECREASING AMPLITUDE OF FINE POSITION ANALOG SIGNAL BY DECELERATING CARRIAGE TO KEEP ALGEBRAIC DIFFERENCE BETWEEN VELOCITY SIGNALS AND POSITION SIGNAL EQUAL TO ZERO.

7F5A

Figure 4-6. Fine Position Servo Signals

The RTZS pulse sets the Load FF, Forward Latch (FF), First Seek FF, and Seek FF. It also causes the difference counter to be set to 495 and since the counter works with complements, this value amounts to a request for an 16-cylinder seek. (Changing of the counter content will be inhibited until after the forward end of travel limit is sensed.) The net result is that the positioner performs a forward 16-ips access.

The carriage continues forward until the first even cylinder pulse (cylinder 406) occurs after the forward end of travel limit (located between cylinders 404 and 405) is sensed. This combination of occurrences causes the carriage to begin reversing. It also causes the content of the difference counter to change to 105 (complement of 406). As the carriage is reversing, only odd cylinder pulses are gated to increment (to 106) the difference counter, and as long as the forward end of travel limit is up, each even cylinder pulse triggers a strobe that resets the counter to 105. The result is that as the reverse moving carriage moves back inside of the forward travel limit, the difference counter content becomes 107 (complement of 404) as cylinder 404 is crossed. With the difference counter calling for a 404-cylinder seek, the positioner responds by performing a reverse seek to cylinder 00 in the following sequence:

1. Accelerates to 50 ips and proceeds until 64 cylinders remain.
2. Decelerates under control of the desired velocity generator from 50 ips to 25 ips which is maintained until 32 cylinders remain.
3. Decelerates under control of the digital to analog converter during the next 31 cylinders.
4. Moves the last cylinder and stops under control of the fine position analog signal.

Refer to Direct Seek paragraph for a detailed description of Servo Circuit operation.

The unit sends a ON Cylinder (and Attention) signal to the controller 1.75 ms after reaching cylinder 00. (If the period starting when the seek motion first begins exceeds 400 ms, a Seek Incomplete signal is generated when the carriage achieves on-cylinder and accompanies the On Cylinder signal.) The deck is now ready to perform a Read, a Write, or a Seek (Direct or RTZS) operation. Such an operation must be preceded by the selecting sequence (Figures 4-1 and 4-2).

READ/WRITE/ERASE

An On Cylinder signal indicates to the controller that the selected DSU has completed a seek operation and is awaiting further instructions. If, however, the controller initiated a seek operation in one unit and then in the interim selected another unit, the first unit would make its status known via the Attention interrupt signal. In the latter case, the controller would be required to precede a Read or Write operation with the selecting sequence (covered previously, Figures 4-1 and 4-2).

The following paragraphs cover the sequence of events involved in a Read or Write operation.

A Write operation actually begins before the voice coil positioner moves the heads to the desired cylinder: the Head Select tag gates the identifying number of the head to be used into the Head Address register. When the seek is completed, the unit sends a Attention interrupt signal. Meanwhile, if the controller has selected another unit, this unit will stand by until it is reselected by the controller. In any case, the controller will examine the Seek Error and On Cylinder lines. If a Seek Error exists, an RTZS pulse (sent by the controller) will clear it. If an On Cylinder exists, the controller responds with a Control tag that gates the Read Gate signal (bit 6 of the Bit lines) to the unit. Read Gate is preceded 20 μ s by Control Tag and Bit 5 which turns on the desired head for reading. Read Gate clears the Attention line. As each record of data on the disk pack is reached, the address is read from the Read Data line and compared by the controller with the address of the desired record. (Refer to Section 5 of this manual set, Publication No. 83302400, for detailed information relative to the read/write format.) When the controller is satisfied that the desired record is being read, it drops the Read Gate and gates in the Write Gate and Erase Gate (bits 0 and 4 of the Bit lines) with the Control tag. This disables the read circuit and enables the write circuit, and data from the controller is written via the Write Data line onto the disk pack record. The Erase Gate signal enables erase current to the erase coil during the Write operation.

A Read operation is performed in much the same manner as the Write operation. The difference is that the Write Gate signals are never enabled (Read Gate stays on throughout the record).

ASSEMBLIES

POWER SUPPLY

Each DSU cabinet has a self-contained power supply accessible via the front door. The power supply provides a fixed output voltage of ± 36 volts for use by the voice coil positioner on the deck assembly. It also provides output voltages of +40 vdc (to read/write logic), ± 20 vdc (to logic), and ± 5 vdc (to logic). Basic on/off power control and monitoring is provided at the front panel of the assembly. The power supply is cooled by air delivered through a duct from the blower assembly.

AC/DC Distribution (Figure 4-7)

Input power is made available to the power supply via the closed contacts of the circuit breaker. This input power is applied directly to the blower motor located in the lower part of the cabinet. Voltage is applied to the primaries of T1 and T6 at this time. The same voltage is applied to the solid-state switches SSW1, SSW2, SSW3, (and Start Timer, 50 Hz units only) for the spindle motor, though the voltage is not actually applied to the motor until during the power-on sequence (described in a later paragraph). An ac voltage (approximately 24 volts) is picked off the secondary of T1 and applied to SSW4 for the brush motor, but again application of the voltage to the motor does not occur until the power-on sequence.

The dc power distribution begins with the application of input power to the primaries of T1 and T6. In the case of T1, four distributable voltages developed across the secondary windings are applied to rectifier/filter circuits. The ± 20 Y voltages used in the power sequencing circuit are available as soon as the primary of T1 receives power. The same is true for the +40 and ± 20 voltages used by the unit's logic chassis. Sequencing of power is required to determine the status of various unit components during a power-on sequence. The remainder of the T1-derived dc voltages are distributed by circuit breakers and relay contacts.

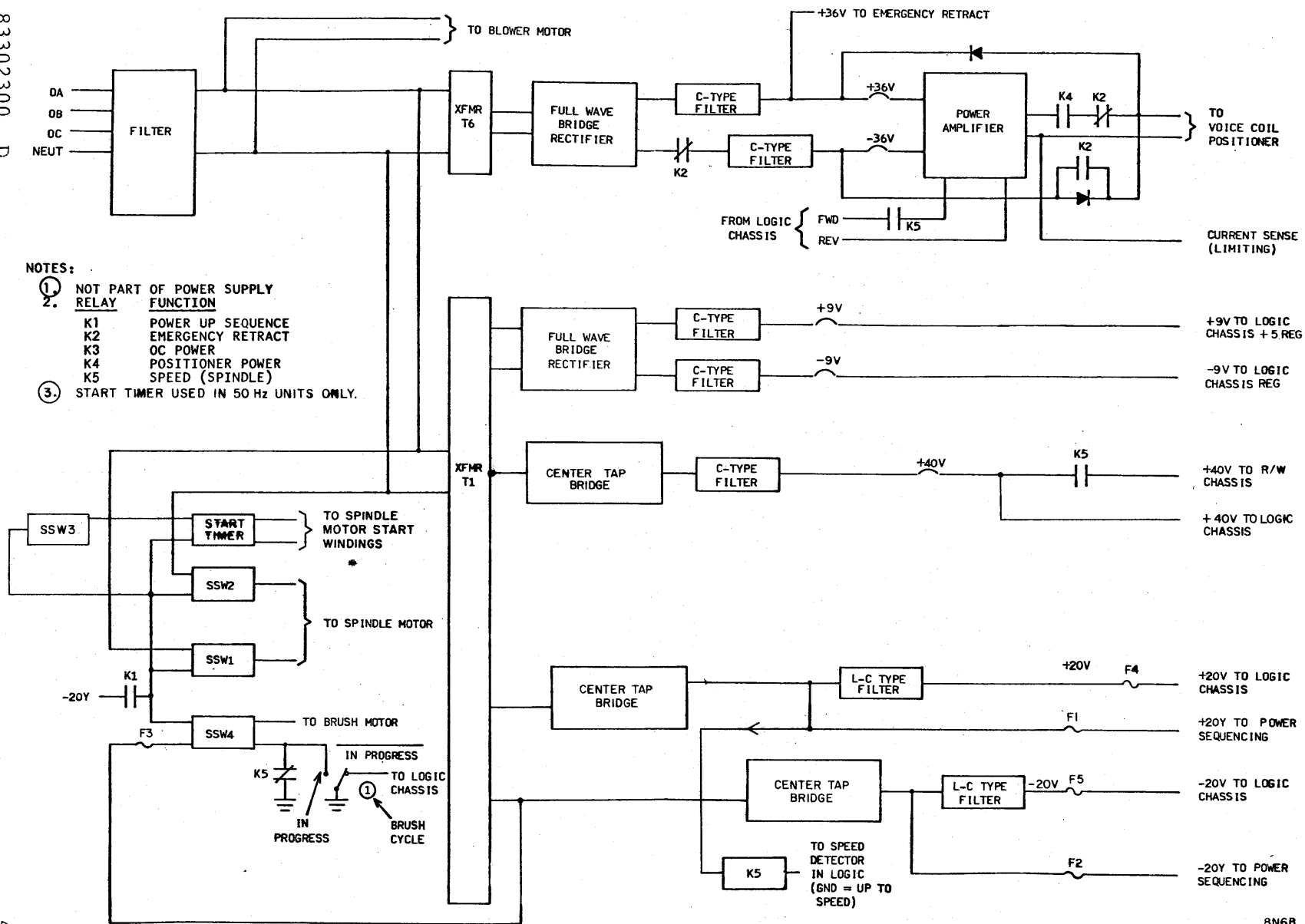

8N6B

Figure 4-7. Power Supply-AC/DC Distribution

The voltages developed across transformer T6 are similarly rectified and filtered. Circuit breakers control application of the voltages to the voice coil positioner power amplifier.

Power-On Sequence

Power application to a unit is sequenced up by relays in the power supply (Figures 4-7 and 4-8). Sequencing is required to prevent damage to read/write heads and/or disk packs.

A normal on-line, power-on sequence begins when the START/STOP switch on the operator panel is set to START so as to light the POWER ON indicator. The progression of the sequence assumes that all power supply circuit breakers are on, that all power supply fuses are operational, that a disk pack is installed, that the cabinet pack access cover is closed, that the index sensor is in position, and that sequence voltage to relay K1 is available.

NOTE

Although step 1 occurs prior to setting the START/STOP switch to START, it is considered a part of the power-on sequence.

1. When the AC circuit breaker was set to ON, the blower motor started, +40 and ±20 volts was applied to the logic chassis, and +20Y voltage became available (Figure 4-7).

NOTE

If controller sequence voltage and ground is available at this point, K1 will energize and steps 3a and 4 will occur even though step 2 has yet to be performed.

2. Place operator panel START/STOP switch to START (Figure 4-8).
3. Controller-issued sequence voltage energizes K1 via the pick line (Figure 4-8). Closing contacts of K1 cause the following:
 - a. Apply holding current to the armature of relay K1.
 - b. Apply -20Y volts to solid-state switches SSW1, SSW2, SSW3, SSW4, (and Start Timer, 50 Hz units only) Figures 4-7 and 4-8. This enables the solid-state switches to conduct the previously applied ac power. The

83302300 D

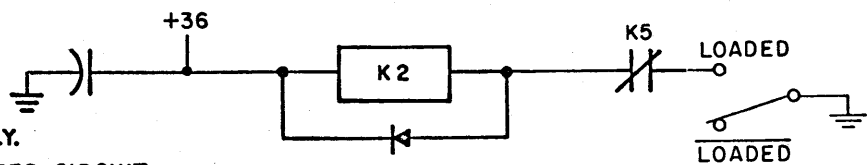
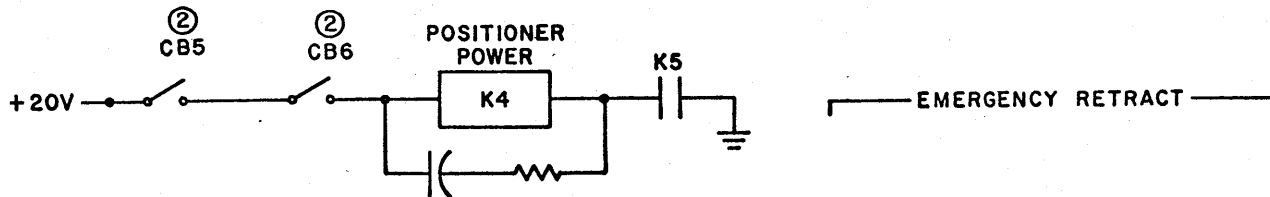
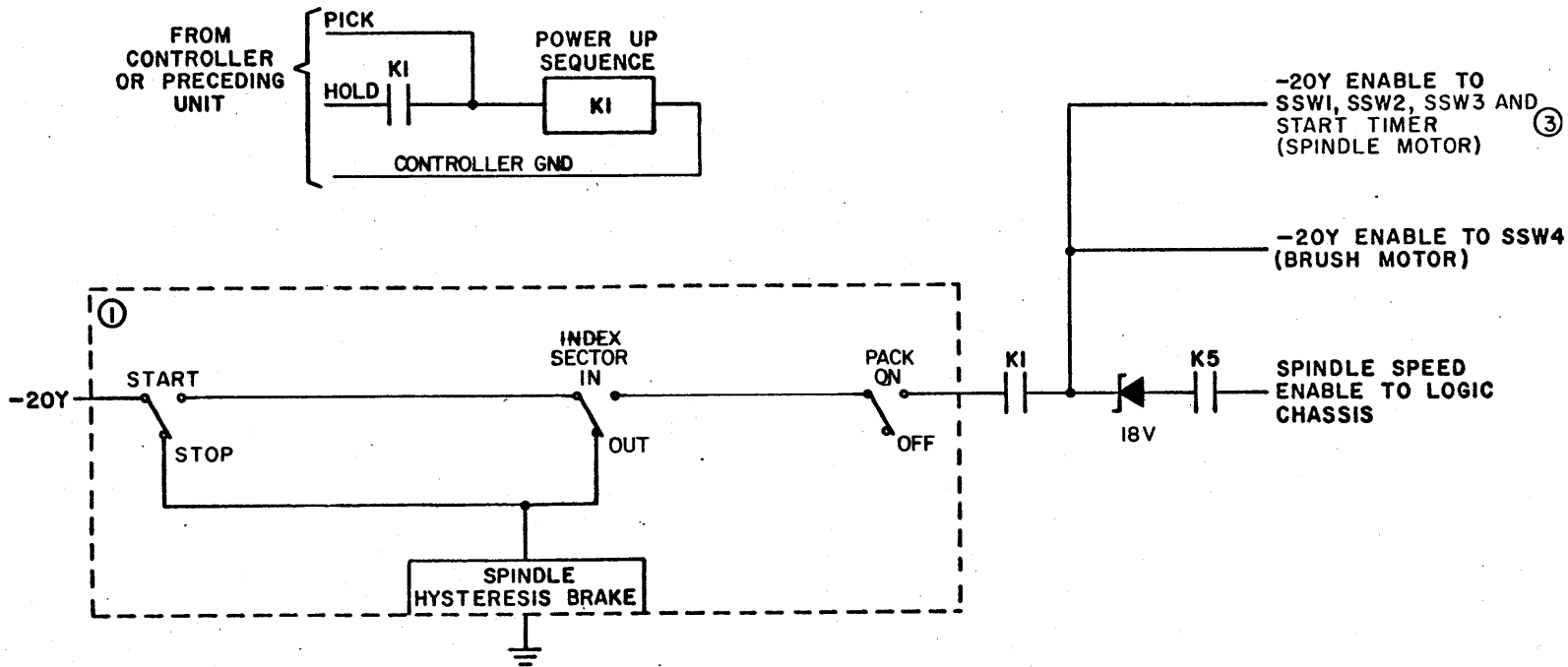

NOTES

- ① NOT PART OF POWER SUPPLY ASSEMBLY.
- ② AUXILIARY SWITCH CONTACTS ON RELATED CIRCUIT BREAKER (SHOWN IN OFF POSITION).
- ③ START TIMER USED IN 50 Hz UNITS ONLY.

8N36

Figure 4-8. Power Supply-Sequencing

spindle motor and brush motor start and the brush cycle switch transfers to the in-progress position. SSW3 switches the spindle motor start windings and drops out at approximately 100 rpm.

4. When the logic chassis speed detection determines that the spindle speed is adequate, relay K5 energizes. The contacts of K5 cause the following:
 - a. Distribute +40 volts to the read/write logic.
 - b. Send a speed enable signal to the logic chassis (Figure 4-7).
 - c. Pass the sequence voltage on to the next unit in line.
 - d. Remove one of two grounds to SSW4 which is controlling the operating brush motor (Figure 4-7).
 - e. Energize relay K4 (Figure 4-8).
5. The transferring contacts of K4 connect the power amplifier to the positioner so that the logic may begin providing motion commands to the positioner (Figure 4-7).
6. As the disk pack cleaning brushes return from sweeping the disk surfaces, the brush cycle switch mechanically transfers to the not in-progress position. This removes the remaining ground to SSW4 and disables the brush motor. It also signals completion of the brush cycle to the logic chassis (Figure 4-7).
7. Completion of the brush cycle allows the start of the First Seek (load heads) function. Upon completion of the First Seek operation the unit is ready to respond to commands from the controller.

Power-Off Sequence

The normal power-off sequence begins when the operator panel START/STOP switch is set to STOP so as to extinguish the POWER ON indicator. The progression of the sequence is as follows:

1. Set operator panel START/STOP switch to STOP (Figure 4-8). The -20Y voltage is switched to cause the following:

- a. Absence of -20Y voltage to SSW1 and SSW2 removes ac voltage to spindle motor.
 - b. Presence of -20Y voltage at spindle hysteresis brake causes rapid deceleration of disk pack.
 - c. Spindle speed enable to logic chassis drops. This disables read/write logic and causes the carriage to begin moving in reverse toward a point where the read/write heads unload.
2. When the logic chassis speed detection determines that the spindle speed is below 2000 rpm, relay K5 de-energizes causing the following:
 - a. Removes +40 volts to the read/write circuits (Figure 4-7).
 - b. Opens the ground side of relay K4 (Figure 4-8). (The capacitor in parallel with the K4 armature will take approximately 300 ms to discharge during which time K4 remains energized.)
 3. If the heads loaded switch has transferred (indicating heads are not loaded) prior to K5 de-energizing, or if it transfers before relay K2 energizes, the carriage continues in reverse at 16 ips to the retracted stop. When K4 de-energizes, its contacts disconnect the power amplifier from the positioner (Figure 4-7) and the power-off sequence is completed.
 4. If, however, the heads are still loaded when relay K2 energizes, the contacts of K2 will cause an emergency retract as follows:
 - a. One set of contacts disconnects the rectifier from the -36 volt side of the power amplifier (Figure 4-7); another set gates the -36 volt line directly to the positioner.
 - b. The charge stored on the -36 volt capacitive filter discharges through the positioner causing the carriage to be retracted at approximately 60 ips.
 - c. When the heads unload, relay K2 de-energizes, the carriage is at the retracted stop, and the power-off sequence is complete.

LOGIC CHASSIS

The logic chassis assembly consists of a logic card section and a maintenance panel. The assembly is accessible through the cabinet rear door. One end of the assembly is hinged to allow access to the front and rear surfaces of the chassis as well as to elements mounted on the underside of the deck. A flexible hose delivers air from the blower housing to the logic chassis. The blower fan is energized whenever the AC circuit breaker is on, and provides cooling air to the logic card section. The front and back covers of the assembly can be removed (four half-turn fasteners each cover) to gain access to cards, wire wrap pins, and related wiring.

The logic card section contains the bulk of the logic cards used in the cabinet (four cards are located on the deck assembly). The vertically mounted cards are installed in a row. Refer to Section 5 (Publication No. 83302400) for a description of the logical functions performed by the cards. Section 7 (Publication No. 83302400) provides a physical description of the cards. Section 9 (Publication No. 83302400) contains a tabulation of the wire wrap connections made in the chassis.

DECK ASSEMBLY

The deck assembly (Figure 4-9) is responsible for the dynamic operations of a DSU: driving disk packs, and loading and positioning the read/write heads. The deck assembly consists of a deck plate on which are mounted a drive motor assembly, a spindle assembly, a hysteresis brake assembly, an actuator assembly, an index sensor, and a disk cleaner assembly.

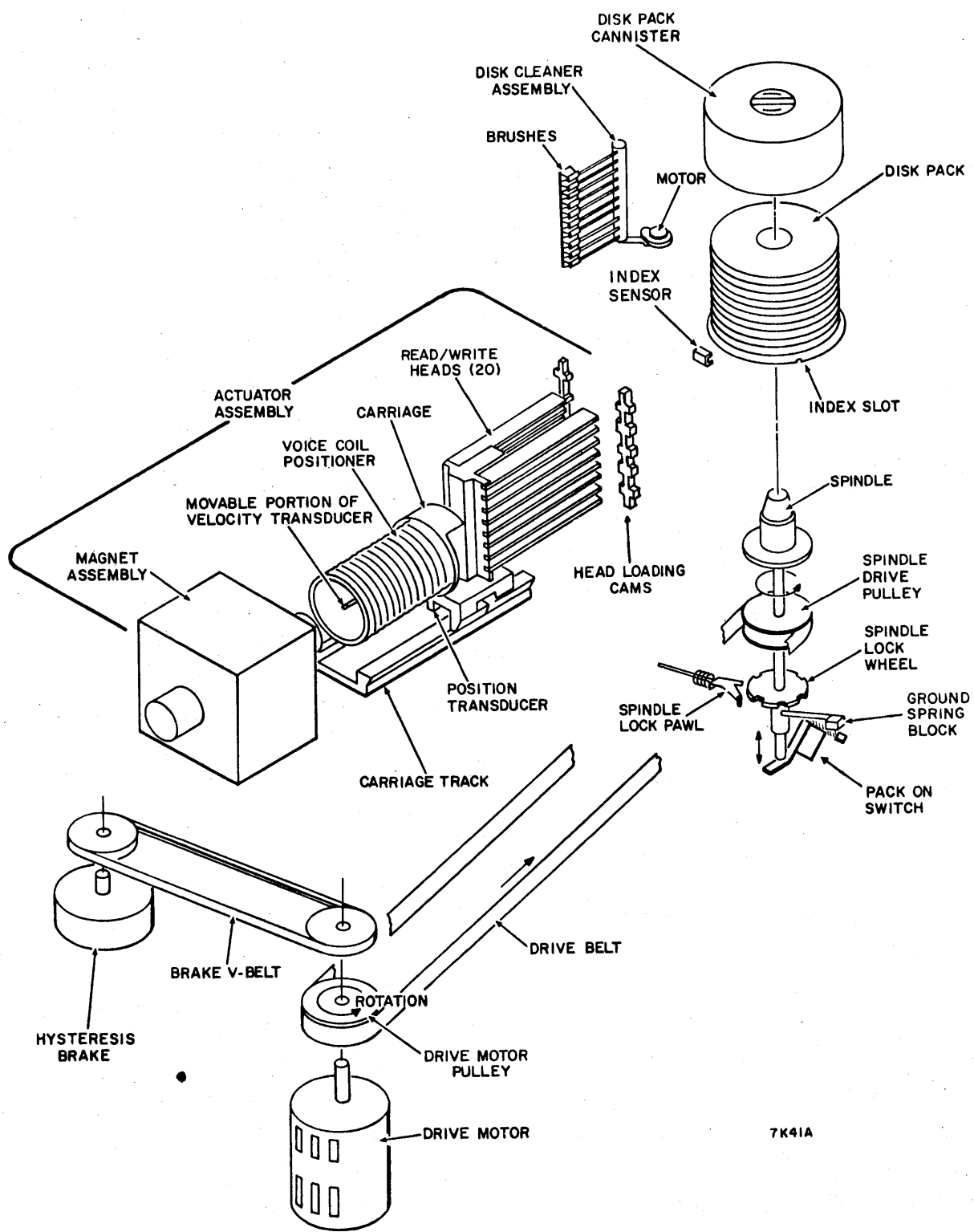

Figure 4-9. Deck Assembly

Drive Motor Assembly

The drive motor drives the spindle assembly. The motor is an induction type, 1/2-hp unit, and is attached to a mounting plate. The mounting plate is secured to the underside of the deck plate in such a manner as to control belt tension. Power is transferred to the spindle via a flat, smooth-surfaced belt that threads over the pulleys of the spindle and drive motor. An idler spring maintains a constant tension on the motor mounting plate, and hence, the belt.

A second pulley on the drive motor shaft links the motor (via a V-belt) to the hysteresis brake.

The temperature of the motor is monitored by a thermal protection switch. To restore operation after an over-temperature condition, the red, 1/4-inch button on the lower end of the motor must be manually reset (pressed).

Hysteresis Brake Assembly

The hysteresis brake decelerates the drive motor assembly during a power-off sequence (refer to Power Supply, Power-Off Sequence paragraph). The brake mounts on a plate which is, in turn, mounted on the motor mounting plate. The brake and motor shafts are linked via a V-belt and a pulley on each shaft.

The brake consists of two cylindrical permeable bodies. These cylinders are assembled, one inside the other, with a uniform gap separating the outer diameter of one from the inner diameter of the other. These adjacent surfaces are machined to contain a series of pole faces. A non-magnetic material, in the shape of a cup, fits in the gap to separate the cylinders. This cup is connected to the brake shaft. As long as spindle motor power is applied, brake power is not available and the cup is driven at the speed of the motor. When spindle motor power is removed, braking power is applied. As braking voltage (-20 volts) is applied to the inner cylinder, a flux field is created between the inner and outer cylinder pole faces. The flux field sets up what is in effect magnetic friction between the inner cylinder and the cup, causing the cup (and brake shaft) to decelerate. Brake deceleration, in turn, causes spindle motor deceleration.

Spindle Assembly

The spindle assembly is the physical interface between a DSU and a disk pack. The conical surface of the spindle cone (Figure 4-10) mates directly with the cone shaped opening in the center of the disk pack.

Starting in the spindle cone and running through the center of the spindle assembly is the vertically free-floating lockshaft. The upper end of the lockshaft contains internal threads that engage the external threads of a stud projecting from the disk pack. When the disk pack cannister cover handle is rotated clockwise, the spring-loaded lockshaft is pulled upward and the disk pack is pulled down. As a result, the conical surfaces of the disk pack and the spindle cone are engaged by a force of approximately 200 pounds. When the disk pack is fully engaged, a release mechanism in the cannister handle frees the cannister from the disk pack.

A notched wheel is secured to the bottom surface of the drive pulley. The notches of the wheel are engaged by the tip of the spindle lock pawl (Figure 4-9) when the front cover is fully open. This locks the spindle, making it easier to install or remove a disk pack. Opening fully the front cover of an operating deck will cause a loud ratcheting noise. Such action, while not recommended, will not cause damage. The spindle drive pulley is driven by a flat belt linking it to the drive motor pulley.

The pack-on switch and ground spring are mounted at the lower end of the spindle assembly. The ground spring block is mounted so that it is always in contact with the lock shaft to bleed off accumulations of static electricity. The pack-on switch contacts transfer in response to the vertical movement of the lockshaft. When the shaft is up (disk pack mounted) the contacts are closed. When a pack is not installed, the shaft moves downward to deflect the switch actuator and transfer the contacts. The switch is part of the interlock that stops application of power to an improperly configured unit.

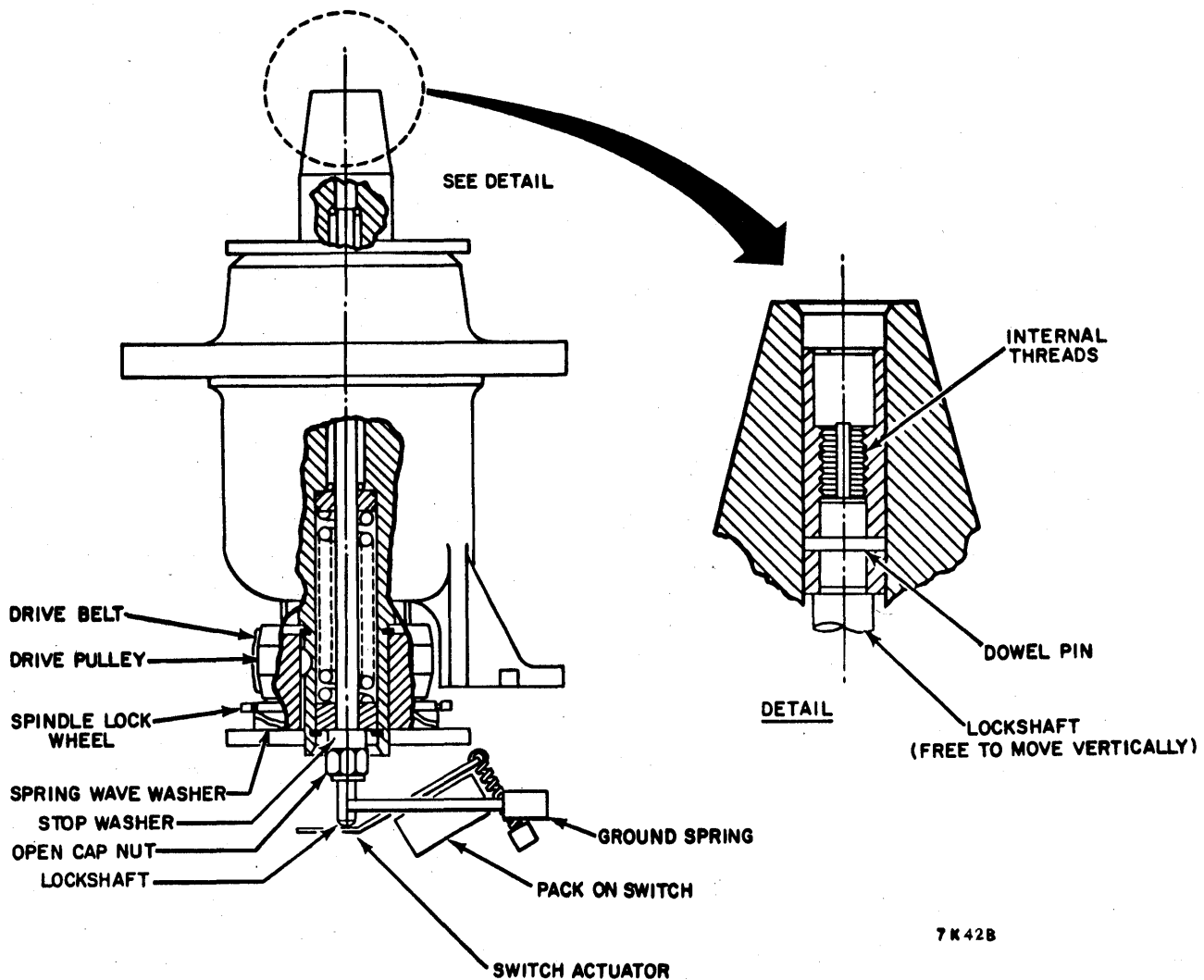

Figure 4-10. Spindle Assembly

Actuator

The actuator consists of the carriage, actuator housing, rails, cams, and magnet assembly. The actuator (Figure 4-11) is the device that supports and moves the read/write heads. The lateral forward and reverse moves of the carriage on the carriage track are controlled by a servo signal. The basic signal is developed in the logic section and processed by a power amplifying stage in the power supply. The power amplifier output is applied to the voice coil positioner (part of carriage). The signal

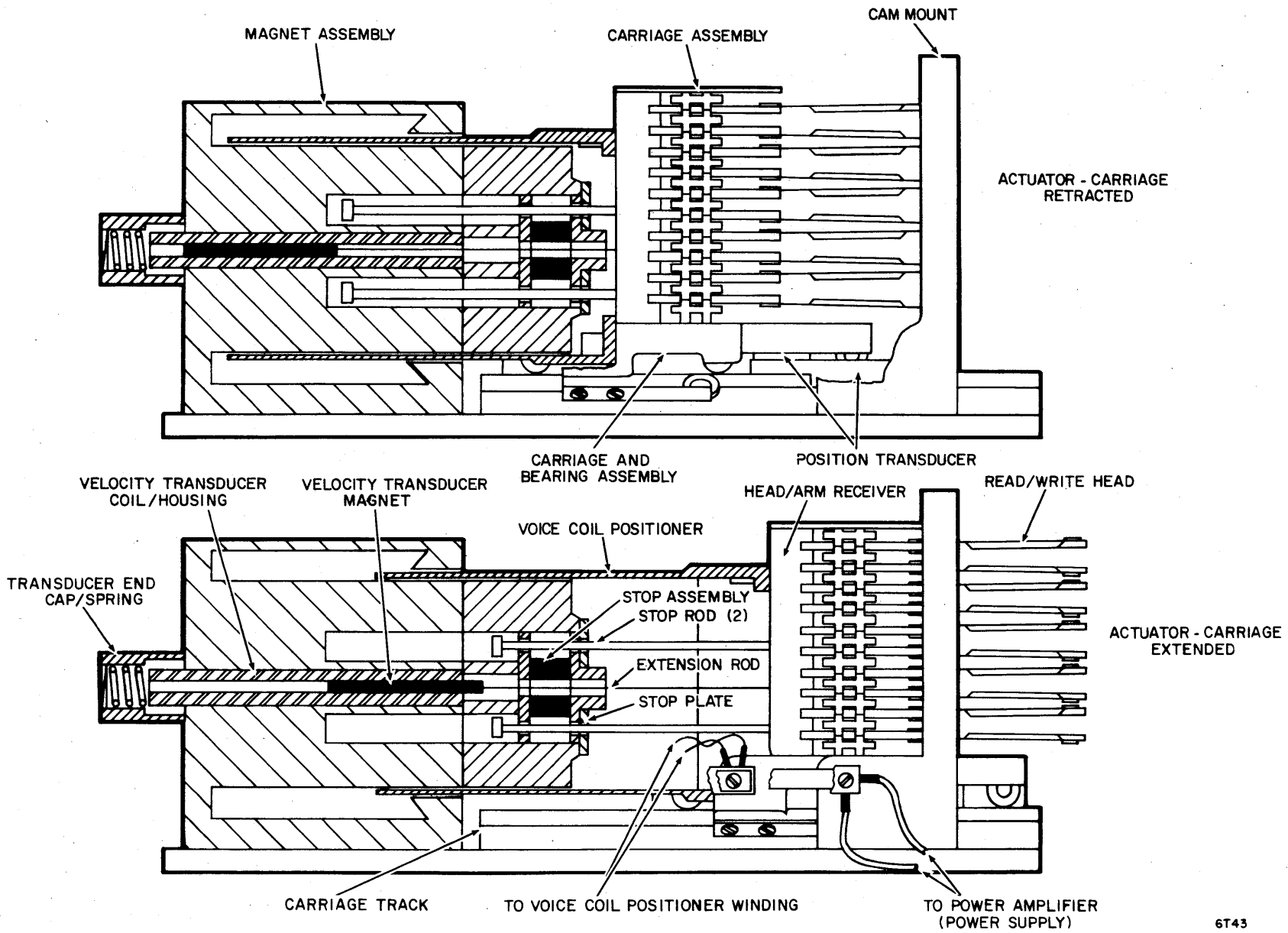

Figure 4-11. Actuator Assembly Elements

causes a magnetic field about the voice coil positioner. This magnetic field reacts with the permanent magnetic field existing around the magnet assembly. The reaction either draws the voice coil into the permanent magnet field or forces it away. Signal polarity determines the direction of motion, while signal amplitude specifies the velocity of the motion.

The voice coil positioner is a mandrel-wound coil that is free to slide in and out of the forward face of the magnet assembly. Fastened to the positioner is a head/arm receiver which holds the 20 read/write heads. The head/arm receiver mounts on the carriage and bearing assembly that moves along the carriage track on four pairs of opposed rollers. Movement of the positioner in or out of the magnet causes the same motion to be imparted to the entire carriage assembly. This linear motion is the basis for positioning the read/write heads to a particular track of data on the disk pack. (Refer to Head Loading paragraph in this section for detailed information on read/write head loading and unloading.)

The positioning signal is derived in the logic chassis and power supply. The signal is applied to the voice coil positioner via two flexible, insulated metal straps, the ends of which are secured to the cam mount and the carriage and bearing assembly.

During any seek operation the logic must be informed of the current location and travel velocity of the carriage. This information is provided by the velocity transducer in the magnet assembly and the position transducer located under the carriage and bearing assembly. Both transducers are two-piece devices: one piece stationary and the other movable. Refer to the Transducer paragraph for a detailed description of operation.

The actuator contains a stop mechanism to limit extremes in forward and reverse movement. The stop assembly is a rubber cylinder sandwiched between two metal plates. If the carriage moves too far toward the disk pack, the stop rod heads contact the plate on the magnet-side of the rubber cylinder. If the carriage is retracted far enough away from the disk pack, the rear of the head/arm receiver contacts the stop assembly stub protruding through the stop plate.

Head Loading

The read/write heads must be loaded to the disk surfaces before exchanging data with the controller. The heads must be removed from this position (unloaded) and driven clear of the disk pack when power is removed to the unit or the disk pack velocity falls below a predetermined rpm. The actuator components involved in these operations are identified in Figure 4-12.

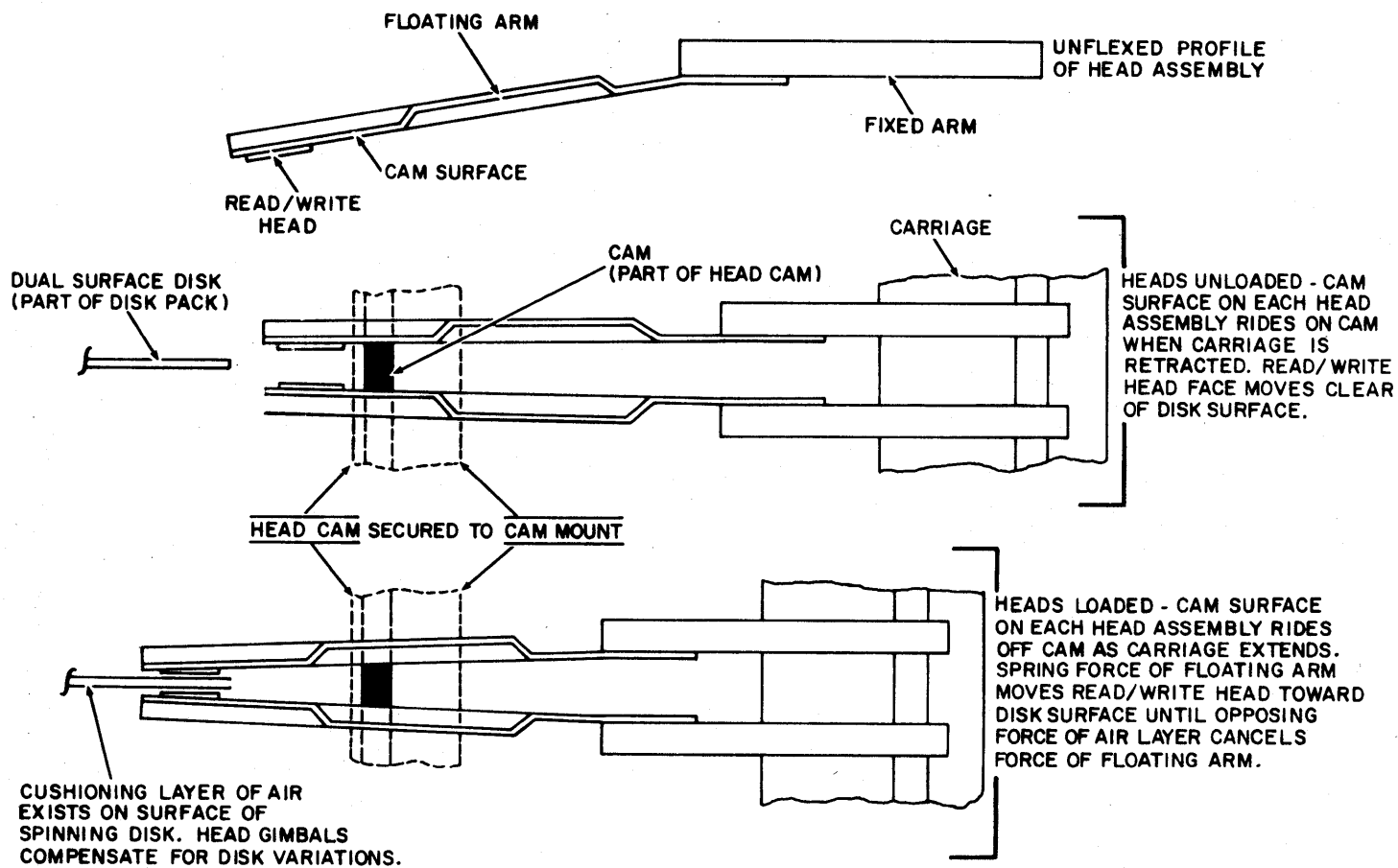

6T42

Figure 4-12. Head Loading

Head loading amounts to allowing spring pressure of the floating arm (part of head/arm assembly) to move the aerodynamically shaped head face toward the related disk surface. When the cushion of air that exists on the surface of the spinning disk is encountered, it resists any further approach by the head. Spring pressure is designed to just equal the opposing cushion pressure (function of disk pack rpm) at the required height. As a result, the head flies. However, if the spring pressure exceeds the cushion pressure (as would happen if the disk pack lost enough speed), the head will stop flying and contact the disk surface. This could cause damage to the head as well as the disk surface.

To prevent damage to the head and/or the disk pack during automatic operation, loading occurs only after the disk pack is up to speed and the heads are over the disk surfaces. For the same reason, the heads unload automatically and are retracted if the disk pack rpm drops out of tolerance. During manual operations, heads should never be loaded on a disk pack that is not rotating. Head loading is a part of the First Seek function. As power to the deck is sequenced up, the drive motor starts. This initiates disk pack rotation and a brush cycle (approximately 20 seconds). When the disk pack rpm reaches 2000, the power supply speed relay energizes to establish the ability to continue the operation. Upon completion of the brush cycle (brushes clear of disk pack), the logic specifies a forward seek and the carriage moves forward toward the spindle and the forward end of travel marker (part of position transducer). Head loading occurs during this forward motion.

The floating arm (Figure 4-12) is designed to maintain a constant loading force. While the heads are retracted, head cams on the actuator housing bear against the floating arm cam surfaces. The cams counter the loading force and force the heads to the unloaded position. As the carriage moves forward the cam surface rides off the cam just after the read/write head moves out over the disk surface. The loading force now moves the head face toward the air layer on the surface of the spinning disk until the opposing forces achieve a state of equilibrium.

The carriage continues toward the spindle until the forward end of travel signal occurs. Upon sensing the next even cylinder pulse, the carriage reverses and returns the now loaded heads to cylinder 00.

The heads loaded switch status reflects the state of the read/write heads (loaded or unloaded). This status is used in the logic chassis. The switch mounts on the carriage track and is transferred by carriage motion. Whenever the carriage is fully retracted, the switch state reflects the unloaded status of the heads. As the carriage moves forward during a First Seek, the switch transfers at a point within 1/4-inch forward of the retracted stop. This switch status remains unchanged until the carriage is retracted to the same position, and, as such, does not precisely indicate the loaded/unloaded status of the heads.

Head unloading occurs whenever power to the unit is removed or disk pack rpm drops below tolerance. Either occurrence drops a speed enable signal to the unit's logic. This causes the carriage to drive in reverse from its current location toward the retracted stop. (One of two methods, one normal the other emergency, can be used. Refer to Power Supply Assembly, Power Off Sequence for additional information.) As the carriage retracts, the cam surfaces encounter the head arms and each head rides vertically away from the related disk surface. The carriage continues back to the retracted position and stops.

Head/Arm Assemblies

Twenty head/arm assemblies are mounted on the carriage. A head/arm assembly consists of a read/write and erase coil package (head assembly) mounted at the end of a supporting arm structure.

The head assembly (Figure 4-13), which includes a cable and plug, is mounted on a gimbal ring which in turn is mounted on a floating arm. This method of mounting allows the head assembly to pivot (independent of the arm) tangentially and radially relative to a data track on the disk surface. Such motion is required to compensate for possible irregularities in the disk surface.

The arm structure consists of a floating arm secured to a heavier fixed arm. The end of the fixed arm opposite the head is installed in the carriage receiver. The floating arm is the mounting point for the head and is necessarily flexible so that it can respond during loading and unloading.

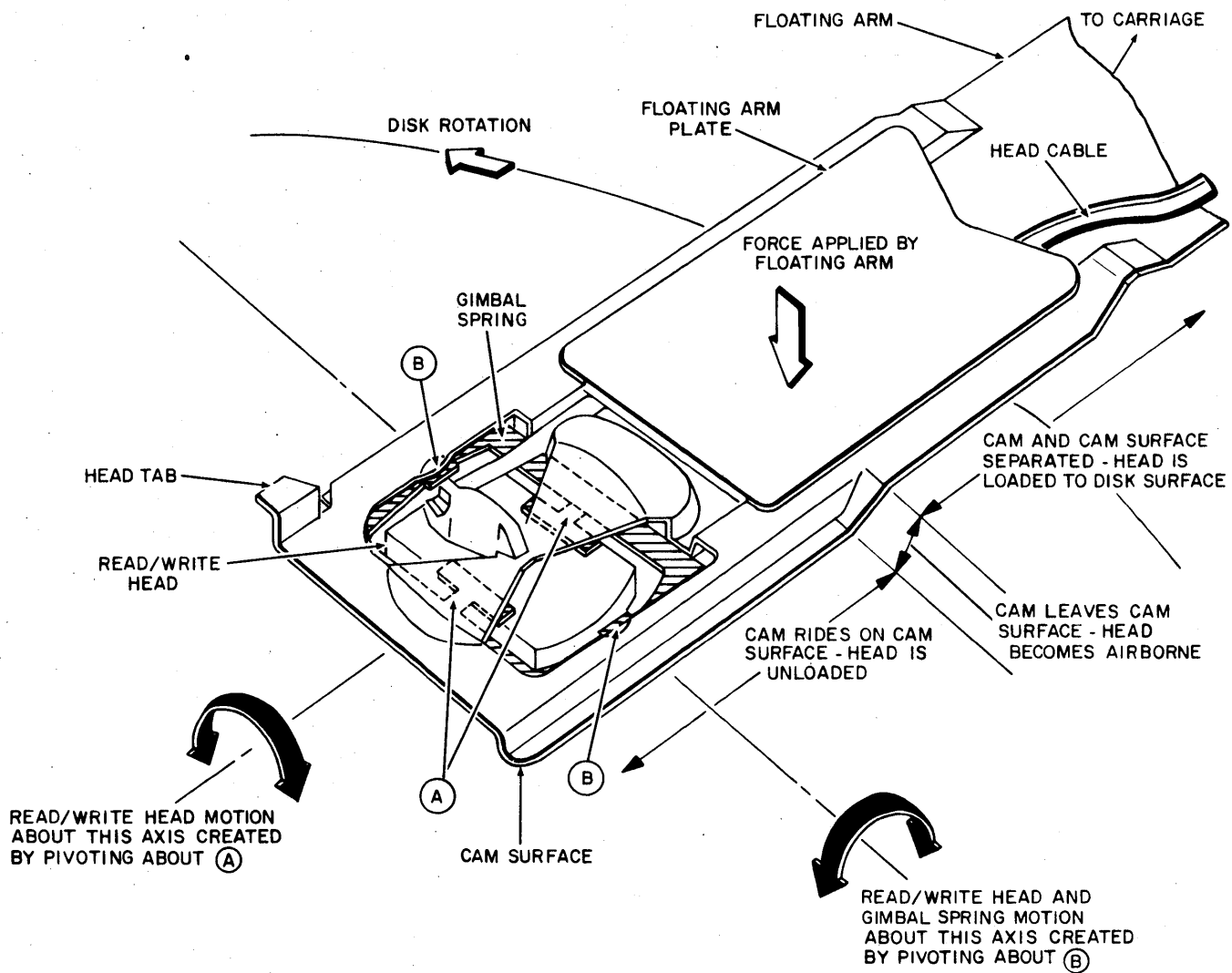

6T41

Figure 4-13. Head/Arm Assembly Motion

The freedom and mobility of the head are necessary elements to being able to function with interchangeable disk packs. During head loading, each floating arm is driven off the related cam and unflexes to force a head toward the air cushion on the spinning disk surface. The force applied by the floating arm causes the heads to fly or float on the air cushion. Vertical motion by a disk surface (due to warpage or imperfection) is countered by a move in the opposite direction by the gimballed head and/or floating arm. As a result, flight height remains nearly constant.

Transducers

The deck assembly contains three transducers: index transducer, velocity transducer, and position transducer. These transducers provide signals that are used by the logic chassis and the controller to generally control the progression of most machine operations.

Index Transducer (Sensor)

This transducer senses a notch in the edge of the index disk (large disk at the bottom of each disk pack). The transducer (Figure 4-14) consists of a light emitting diode (LED) and a photosensitive transistor. Light in the infrared range is emitted from the LED and when allowed to strike the transistor, via a notch, drives the transistor into saturation. This output is processed in the logic chassis.

The notch on the index disk causes the detector (Figure 4-14) to generate a 55- μ sec "1" pulse. These pulses are further processed by the DSU logic to determine if the disk pack speed is sufficient for continued operation.

Velocity Transducer

The velocity transducer (Figure 4-15) is a two-piece device consisting of a stationary, tubular coil/housing and a movable magnetic core.

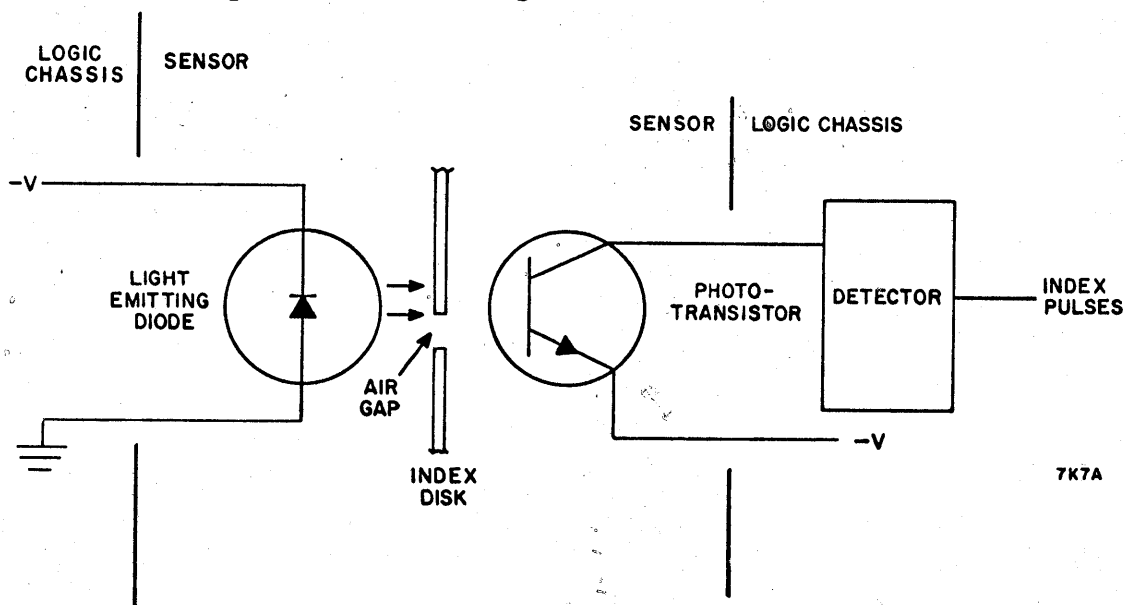

Figure 4-14. Index/Sector Detection

The magnetic core is connected via the extension rod to the rear surface of the head/arm receiver. All motion on the part of the carriage is therefore duplicated by the magnetic core. As the core moves, an emf is induced in the coil. The amplitude of this emf is directly related to the velocity of the core (and carriage). The polarity of the emf is an indication of the direction of movement by the core (and carriage). The transducer output drives an operational amplifier located in the logic chassis.

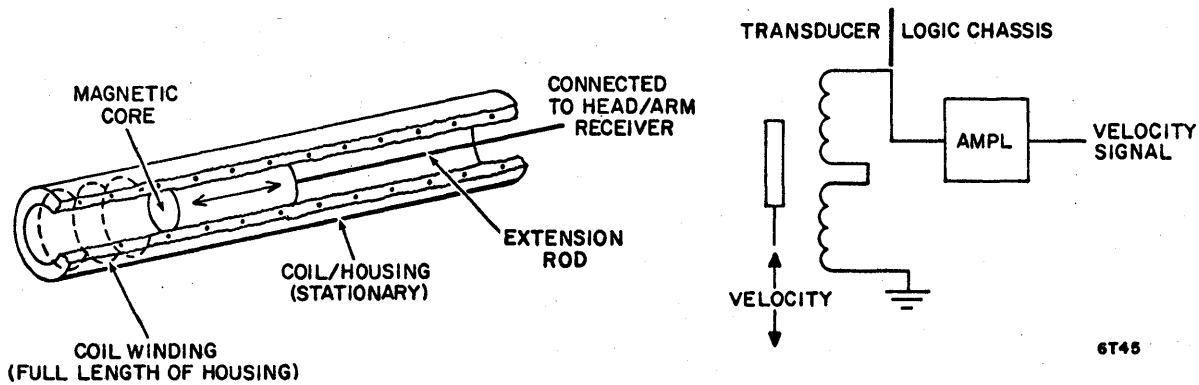

Figure 4-15. Velocity Detection

Position Transducer

The position transducer (Figure 4-16) is a two-piece device that senses the crossing of even cylinders, odd cylinders, the forward end of travel limit, and the reverse end of travel limit. Each of the two pieces is etched with a pattern of windings. One piece mounts on the inner cutout of the carriage track. The other segment (the movable piece) is secured to the underside of the carriage and bearing assembly.

The fixed part of the transducer is excited with a 50 kHz oscillator signal. The proximity of the transducer pieces to each other causes a coupling of this signal to the movable windings. As the carriage moves, in response to the servo signal, the amplitude and polarity of the voltage induced in the movable windings changes.

Figure 4-17 explains the details of this occurrence for both of the two types of windings (cylinder and end of travel). The amplitude variations (caused by carriage motion) modulate each of the four coupled oscillator signals. Each modulated signal is then applied to a separate detection circuit in the logic chassis (Figure 4-16). Figure 4-18 shows the signal activity in these circuits.

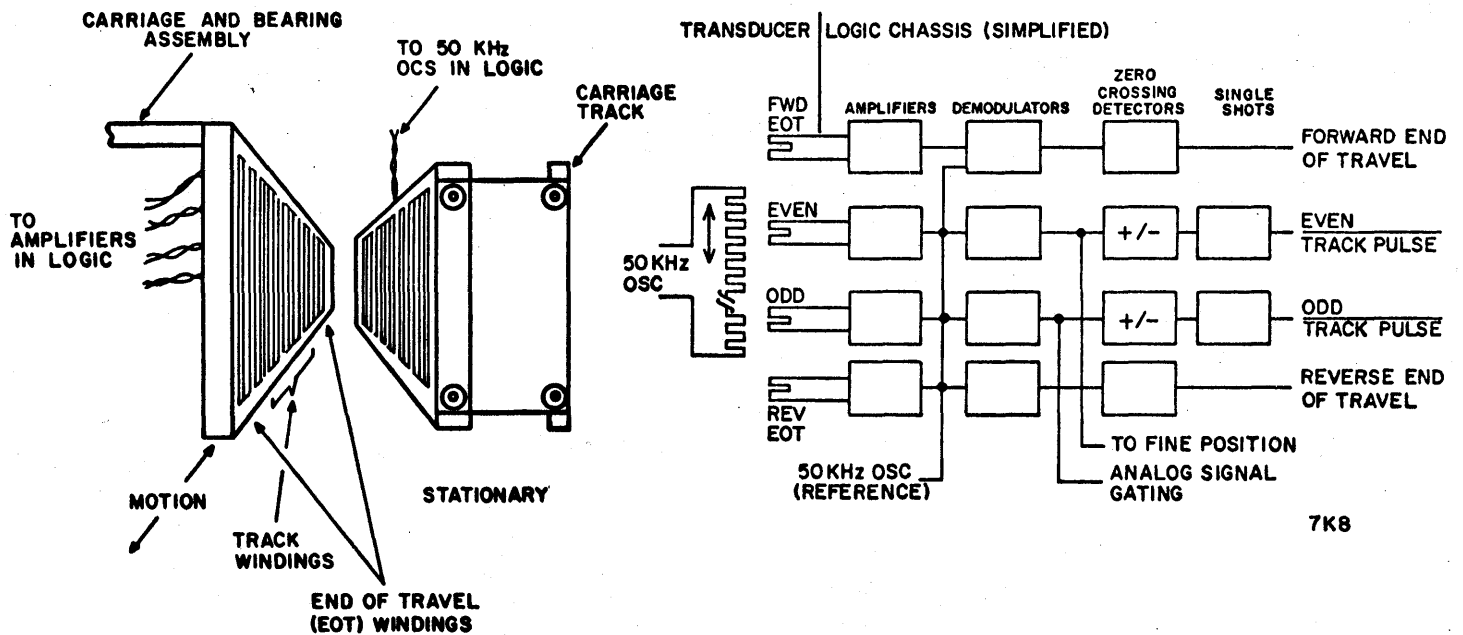

Figure 4-16. Position Transducer/Simplified Detection

The odd and even demodulator signals are tapped off and applied to a gating network. During movement over the last cylinder of any seek operation, the gating circuit selects the appropriate signal for use as the fine position analog signal (stopping signal). Refer to the Direct Seek paragraph for a detailed discussion of the signal.

Disk Cleaner Assembly

The disk cleaner assembly sweeps the disk pack recording surfaces free of any foreign materials. The sweep cycle occurs just before the read/write heads are loaded during the First Seek sequence.

The assembly consists of a motor, 10 comb-mounted brushes, a reset switch, motor to comb linkage, and a mounting base. The base mounts on the deck assembly and the brushes are pivot mounted on the base. Pivoting of the brushes is controlled by the motor, the linkage, and the switch. The motor is energized during the power on sequence and starts a 20-second (approximately) cycle. As the cycle proceeds, the brushes sweep toward the spindle until the linkage causes a reversal in direction.

END OF TRAVEL WINDINGS

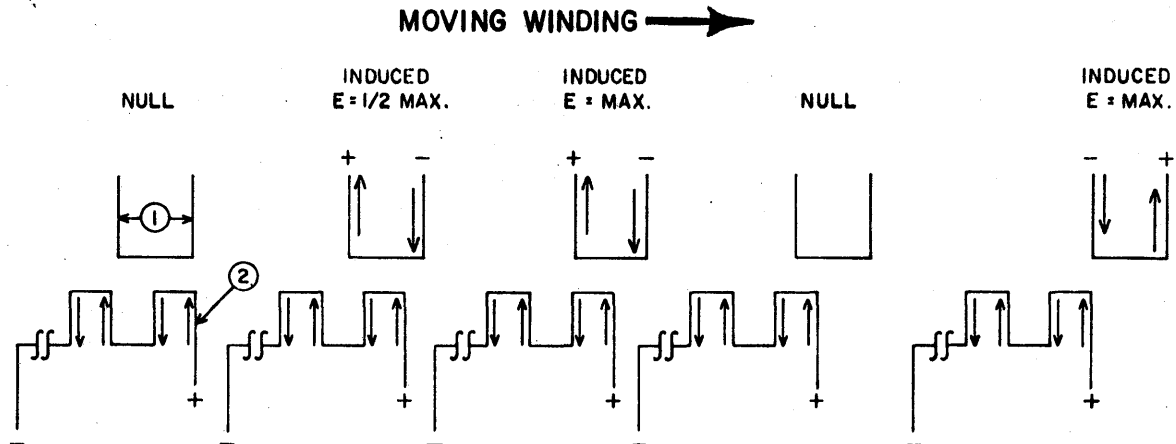

FIXED WINDING 50 KHz OSCILLATOR APPLIED

NOTE: WINDING WIDTH ① CAUSES NULLED OUTPUT AT ALL TIMES EXCEPT WHEN END OF MOVABLE WINDING ② IS ENCOUNTERED.

ODD/EVEN CYLINDER WINDINGS

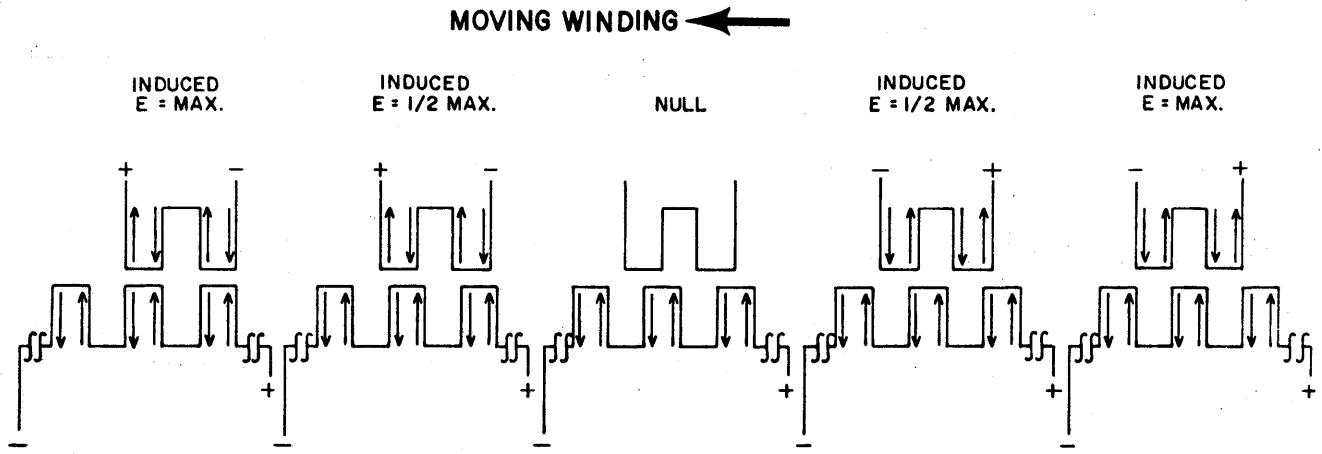

FIXED WINDING 50 KHz OSCILLATOR APPLIED

7K9 A

Figure 4-17. Transducer Winding Induction

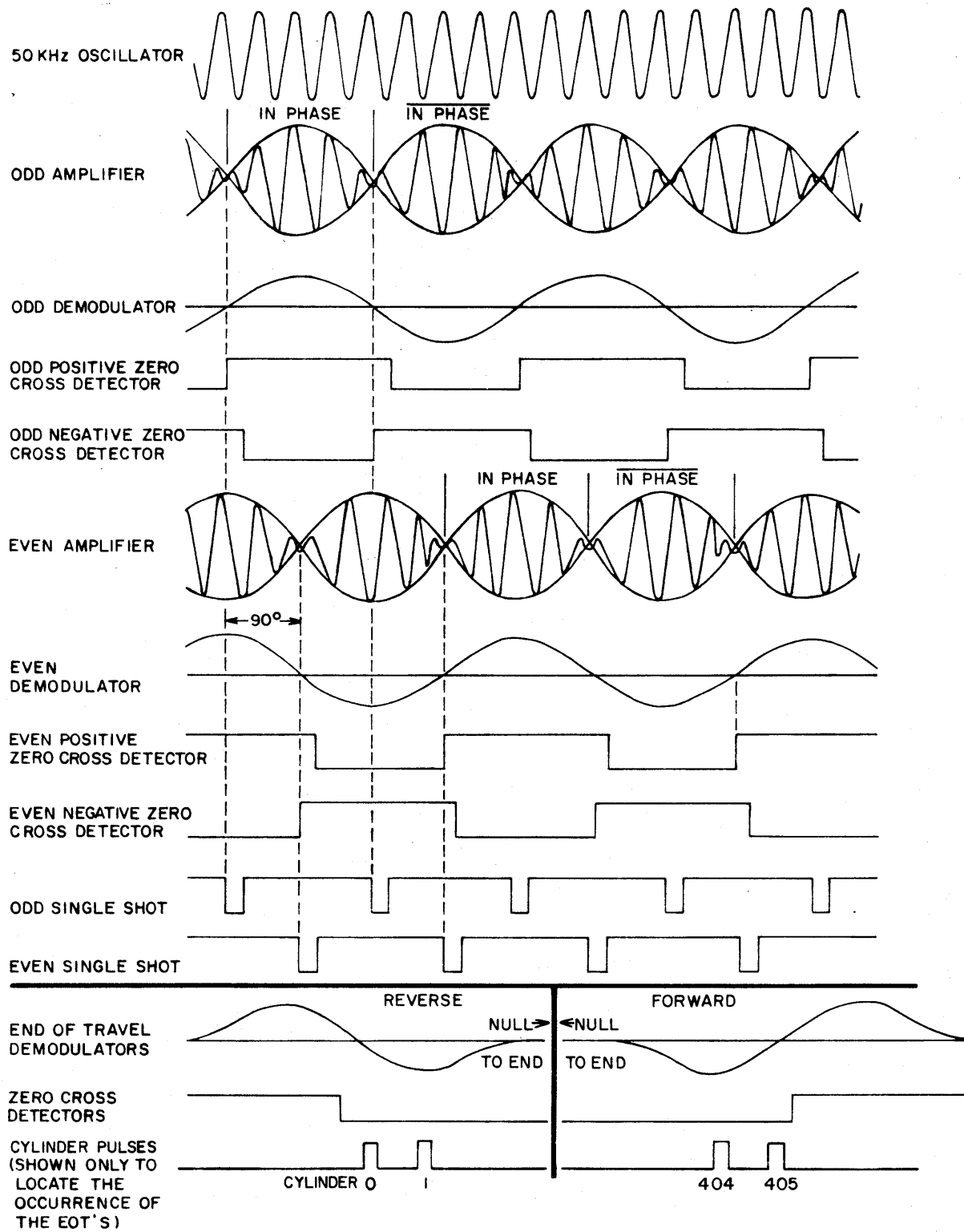

7K10A

Figure 4-18. Cylinder and EOT Pulses

As the brushes return to the original position (clear of disk pack), the reset switch is encountered and transfers so as to disable power to the motor.

The shaft on which the brushes are installed is driven via a ball-slot detent mechanism. If power is dropped or lost during the brush cycle, the operator can override the detent and rotate the brushes clear of the disk pack so that the disk pack can be removed from the spindle. The brush cycle, during the next Power-on sequence, will be an incomplete cycle as the brushes automatically reset themselves. Subsequent cycles will be normal.

BLOWER SYSTEM

The blower system (Figure 4-19) provides positive pressure to the enclosed shroud around the disk pack. The presence of this air flow equalizes the disk temperature and results in an outward dispersion of air over each disk surface. This air flow greatly reduces possible contamination and resulting damage to the disk surfaces and to the read/write heads. The system also provides cooling air to the logic chassis and power supply assembly.

The system consists of a motor driven impeller that draws air in through the primary filter in the bottom of the unit. A portion of this air is forced through an absolute filter (glass and asbestos) and related ducts upward to a chamber in the bottom of the deck and then to the spindle. The remainder of the air is distributed directly from the blower housing (no additional filtering) to ducts leading to the power supply and the logic chassis.

Power to the blower drive motor is controlled by the AC circuit breaker.

DISK PACK

The disk pack is the recording medium for the DSU. The disk pack consists of eleven 14-inch, magnetic oxide coated disks center-mounted on a hub. The recording surface of each disk is coated with 0.0002-inch of magnetic iron oxide and related binders and adhesives.

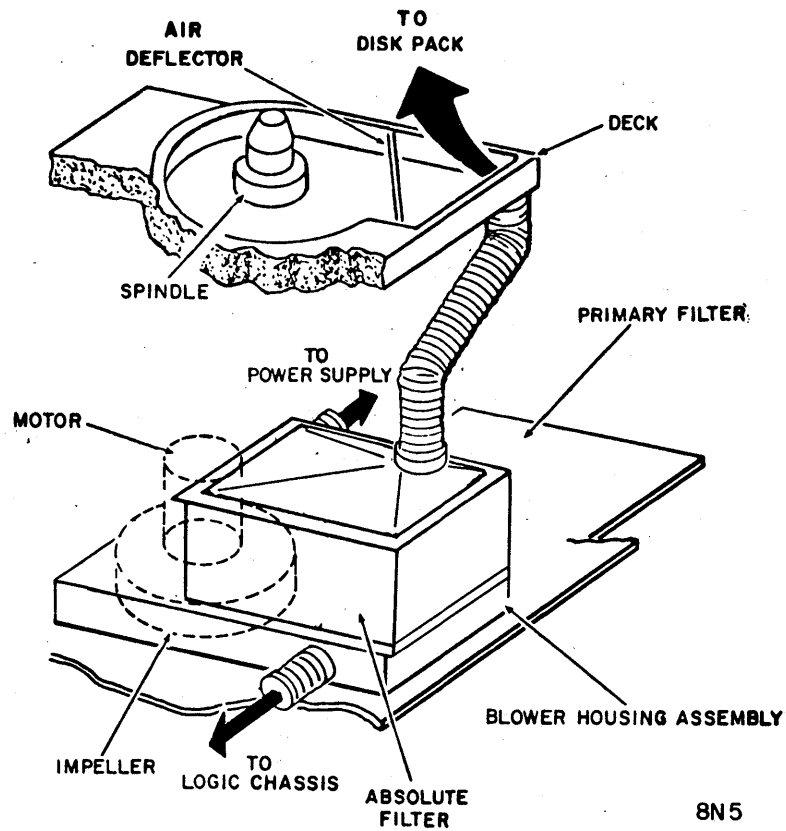

8N5

Figure 4-19. Blower System

The 406 recording cylinders are located in a 2-inch band near the outer edge of the disk. Track 405 has a diameter of approximately 9 inches, while the diameter of cylinder 00 is about 13 inches. The cylinders are spaced 0.005 inch apart.

The top and bottom disk surfaces are covered by protective non-recording disks. The bottom protective disk is called the index disk. This disk contains a notch that is sensed by the index transducer. The pulse outputs of the transducer are used to determine disk pack rpm and to detect organizational segments of the disk pack.

The lower hub of the disk pack contains a replaceable filter. This filter removes particles from the air supplied by the blower. Keeping positive air pressure at the center of the disks, as the blower does, reduces the possibility of damage caused by ingested dust.

The disk pack has a two-piece container assembly. The bottom cover can be removed simply by grasping and rotating the center hub. The top cover is designed so that it can be removed only by installing the disk pack on the deck spindle assembly. The disk pack can be removed from the spindle only by using the top cover (see Section 2). This design protects the disk pack from physical damage and greatly reduces the possibility of contamination of the disk pack recording surfaces.

The 873 disk pack (P/N 89265501) must be used on the unit. The 873 pack is certified at 200 tpi and can be identified by the burnt umber markings on the white trim shield.

SECTION 5

DIAGRAMS

Information for this section is contained in BR5A5
Disk Storage Unit, Publication Number 83302400.



SECTION 6

MAINTENANCE



MAINTENANCE

This section contains the instructions required to maintain a DSU. The information is provided in the form of preventive maintenance, corrective maintenance and troubleshooting.

MAINTENANCE TOOLS

The special tools required to maintain a DSU are listed below:

<u>Tool</u>	<u>Part Number</u>
Belt Tension Gage	CDC® 84267100
CE Disk Pack	CDC 84259000
Card Extender, Full-size	CDC 54109700
Card Extraction Tool	CDC 87399200
Carriage Alignment Ring	CDC 87351000
Carriage Alignment Arm	CDC 87350900
Chip Extender, Chip Cliplog	CDC 12212196
Feeler Gages	CDC 12210940
Hand Staker	CDC 87372900
Head Adjustment Tool	CDC 87350700
Head Cam	CDC 73120600
Head Installation and Removal Tool	CDC 87364400
Multimeter	CDC 18697502
Nutdriver, Hollow Stem	Exelite #6
Oscilloscope	CDC 18695252
Oscilloscope Hood	CDC 12210102
Pin Straightener	CDC 87369400
Post Removal Tool	CDC 12259101

*CDC® is a registered trademark of Control Data Corporation

<u>Tool</u>	<u>Part Number</u>
Push-Pull Gage	CDC 12210797
Removal Tool, 20-30 Gage	CDC 12209122
Torque Screwdriver	CDC 12218425
Torque Screwdriver Bit	CDC 87016703
Wire Wrap Bit, 30 Gage	CDC 12218402
Wire Wrap Gun, Manual	CDC 12210851
Wire Wrap Sleeve, 30 Gage	CDC 12218403

MAINTENANCE MATERIALS

The materials used in the procedures of this section are listed below:

<u>Material</u>	<u>Part Number</u>
Adhesive, Loctite	CDC 12206346
Filter Fluid	CDC 12210958
Gauze, Lint-Free	CDC 12209713
Media cleaning solution (see note)	CDC 95033502
Oil (1/2-pint container)	CDC 12208888
Pack Cleaner	CDC 84323000
Grease, Dielectric, Silicone	CDC 95109000

NOTE

When using the Media cleaning solution do not leave container open because the solution will pick up water from the air.

PREVENTIVE MAINTENANCE

GENERAL

Performance of the DSU is dependent upon the proper and timely execution of a preventive maintenance routine. Such a routine is provided by the Preventive Maintenance Index following.

The index consists of five levels based on a calendar period or hours of operation (whichever comes first). Perform preventive maintenance in accordance with the indication of this meter. The Preventive Maintenance Procedure column lists the title of the paragraph containing the required instructions.

PREVENTIVE MAINTENANCE INDEX

*Level					Preventive Maintenance Procedure	Estimated Procedure Time (Minutes)
1	2	3	4	5		
		X			Inspect and clean disk pack**	5
		X			Inspect actuator assembly	2
		X			Clean front cover glass	1
		X			Clean primary filter**	5
		X			Check power supply outputs	2
			X		Inspect and clean read/write heads	10
			X		Clean shroud and spindle	1
			X		Clean pack cleaning brushes	2
			X		Clean and lubricate lockshaft	2
				X	Replace absolute filter**	20

*Level 1 - Weekly or 150 hours (no preventive maintenance scheduled)

Level 2 - Monthly or 500 hours (no preventive maintenance scheduled)

Level 3 - Quarterly or 1,500 hours

Level 4 - Semiannually or 3,000 hours

Level 5 - Annually or 6,000 hours

**Intervals are maximum times. Preventive maintenance may be required more frequently depending on dust contamination level of operating area.

INSPECT AND CLEAN DISK PACK

1. Stop spindle motor.
2. Open cabinet front cover.
3. Open interior cover.
4. Remove disk pack from spindle.
5. Install disk pack to be cleaned on spindle.

NOTE

Use of a suitably bright and directional light during following steps is recommended. When manually rotating disk pack, override spindle lock ratchet by allowing open front cover to rest on shoulder.

6. Slowly revolve disk pack while observing each disk surface. If severe scratches (oxide coating removed from disk surface to point of baring substrate) are found, refer to Section 7, Maintenance Aids Manual (Pub. No. 83302400) for disk pack replacement criteria.
7. Wrap a piece of lint-free gauze around a plastic spatula (or a tongue depressor) and dampen (do not soak) with Media cleaning solution.
8. Insert the spatula into disk pack until tip contacts hub of disk pack.

NOTE

Apply moderate and constant pressure to disk surface with spatula during following step.

9. Slowly rotate disk pack while very slowly withdrawing tip of spatula. Continue withdrawing spatula until tip is clear of disk pack circumference.
10. Repeat steps 7, 8, and 9 for a disk surface until gauze comes away clean from disk surface.
11. Wrap a clean, dry piece of gauze on spatula and repeat steps 8 and 9 to remove residue released by Media cleaning solution.
12. Repeat steps 7 through 11 for each remaining recording surface of disk pack.
13. Dampen a piece of gauze with Media cleaning solution and wipe clean the exposed top surface of disk pack. Dry the surface.

14. Use alcohol dampened gauze to clean both pieces of disk pack container.
15. Wipe container dry.
16. Remove disk pack from spindle (do not install bottom half of container). Invert container and inspect nylon mesh filter surrounding lower hub of disk pack. If filter is discolored (normally white), replace as follows:
 - a. Release O-ring securing lower rim of filter.
 - b. Remove dirty filter.
 - c. Insert new filter (Control Data P/N 40050500) in cavity and secure with original O-ring.
17. Install bottom of disk pack container. Set pack and container aside.

CAUTION

Bearing damage may occur if Media cleaning solution runs into spindle.

18. Clean spindle cone of DSU thoroughly with Media cleaning solution dampened gauze.

INSPECT ACTUATOR ASSEMBLY

1. Raise cabinet top cover.
2. Inspect entire actuator for presence of dust and other foreign materials. Pay particular attention to following areas:
 - a. Circular cutout in face of magnet assembly (receives voice coil).
 - b. Rail surfaces (particularly the horizontal surfaces) of carriage track on which carriage and bearing assembly travels.
3. Use lint-free gauze dampened (not soaked) with Media cleaning solution to remove deposits or attracted particles.

CLEAN FRONT COVER GLASS

Use lint-free gauze dampened (not soaked) with isopropyl alcohol to remove smudges and deposits from the glass in the front cover.

CLEAN PRIMARY FILTER

1. Open cabinet front panel.
2. Set filter box circuit breaker to OFF.
3. Remove primary filter (Figure 6-1).
4. Agitate filter in mild detergent solution. Rinse in reverse direction with low pressure nozzle.
5. Shake excess water from filter and allow to dry.
6. Spray filter with filter fluid (P/N 12210958).
7. Install filter.
8. Set filter box circuit breaker to ON.
9. Close front panel.

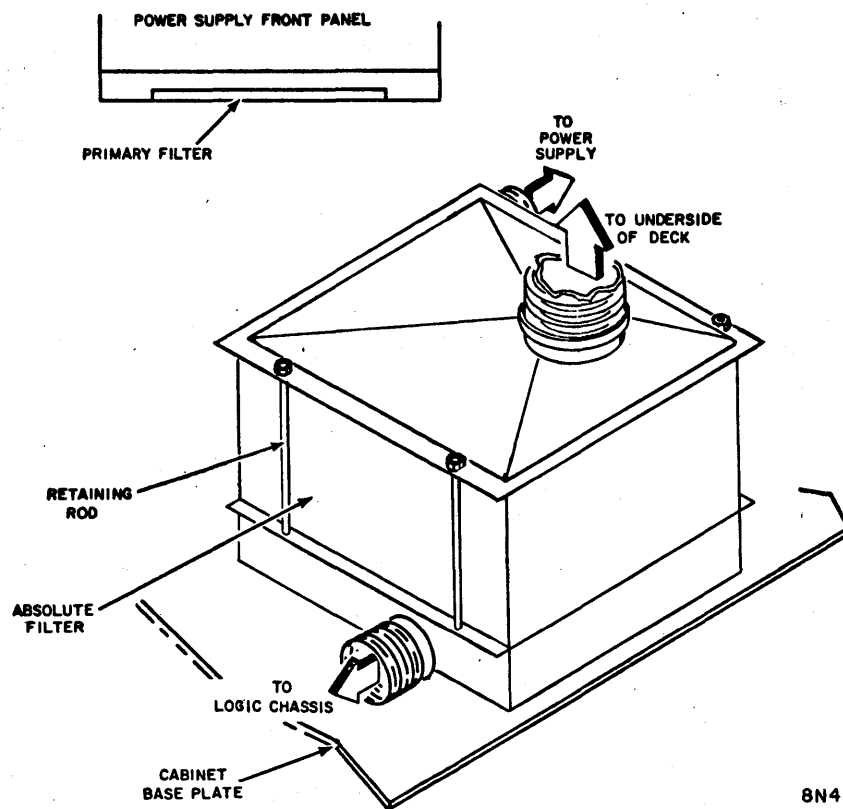

Figure 6-1. Cabinet Filters

CHECK POWER SUPPLY OUTPUTS

1. Open cabinet rear door.
2. Start spindle motor.
3. Load read/write heads.
4. Use an AC/DC voltohmmeter to measure output voltages at corresponding logic chassis locations.

- a. Measure +40 volts at JA84-4B.

Does meter read +40

±2.0 volts? → no

Check the +40v rectifier and filter network.

↓
yes

- b. Measure +20 volts at the +20v receptacle on logic back panel.

Does meter read +20

±2.0 volts? → no

Check the +20v rectifier and filter network.

↓
yes

- c. Measure -20 volts at the -20v receptacle on logic backpanel.

Does meter read -20

±2.0 volts? → no

Check the -20v rectifier and filter network.

↓
yes

- d. Measure +5.1 volts at JD94-4A.

Does meter read +5.1

±0.25 volts? → no

Adjust R17 on the regulator board for an indication of +5.1 volts.

↓
yes

- e. Measure -5.1 volts at JD94-1A.

Does meter read -5.1

±0.25 volts? → no

Adjust R3 on regulator board. for an indication of -5.1 volts.

↓
yes

Procedure completed.

INSPECT AND CLEAN READ/WRITE HEADS

1. Stop spindle motor and open pack access cover and remove disk pack.

NOTE

Use a suitably bright and directional light during the following steps.

2. Inspect heads as follows (carriage must remain fully retracted):

CAUTION

Do not smoke while inspecting. Use extreme care not to damage heads with dental mirror. Gimbal spring (holds head on end of floating arm) is most liable to be damaged. If gimbal spring is permanently bent, entire head/arm assembly must be replaced.

- a. Use dental mirror to inspect face of each head for reddish-brown oxide deposits. Clean head only if deposits exist (see step 3).
 - b. If scratches are found, refer to Maintenance Aids section (Pub. No. 83302400) for head replacement criteria.
3. Clean heads (only if required) as follows:

CAUTION

Do not smoke while cleaning. Do not touch a head face with fingers. When cleaning or buffing, always move tongue depressor perpendicular to length of head/arm assembly. Do not leave residue or lint on head faces. Trapped residual particles can result in the loss of a head and/or a scored disk.

- a. If oxide deposits were found, use lint-free gauze on a tongue depressor to lightly dry-buff the head face. If deposits are removed, cleaning is completed.
- b. If oxide deposits were not removed, dampen (do not soak) gauze with Media cleaning solution and wipe head face. If deposits are removed, use dry gauze to lightly buff head face.
- c. If oxide deposits were not removed in step b, refer to Maintenance Aids (in Publication 83302400) remove head/arm assembly from carriage, and repeat step b.
- d. If oxide deposits still remain, install a new head/arm assembly.

CLEAN SHROUD AND SPINDLE

1. Stop spindle motor.
2. Open top cover.

CAUTION

When top cover of unit is open, care must be used to keep any disk pack at least three inches away from any part of the magnet assembly. Erasure of data can occur.

3. Remove disk pack. Avoid contact with index transducer.
4. Clean shroud with a lint-free gauze that is slightly dampened with Media cleaning solution. Wipe shroud to remove all dirt and smudges. Thoroughly wipe spindle surface.
5. After cleaning shroud, use a wad of adhesive-type tape and pick up any particles that were not picked up with gauze. Make certain that all particles are removed from interior of shroud.

CHECK PACK CLEANING BRUSHES

1. Stop spindle motor.
2. Open top cover.

3. Check brushes for presence of dust or excessive wear.

Has dust accumulated on brushes? →

yes Clean brushes with vacuum cleaner.

no

Do any brushes show excessive wear (Figure 6-2)? →

yes Replace brushes (P/N 40024500).
All brushes should be replaced at same time.

no

Procedure completed.

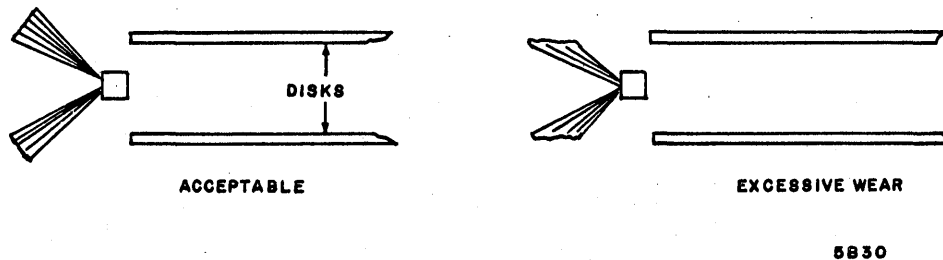

Figure 6-2. Pack Cleaning Brushes

CLEAN AND LUBRICATE LOCKSHAFT

1. Stop spindle motor.
2. Remove disk pack.
3. Open top cover.
4. Use lint-free gauze and a brush or sharp instrument to clean lockshaft threads on top end of spindle.
5. Apply a thin coat of oil (P/N 95020400) to threads.

REPLACE ABSOLUTE FILTER

1. Open cabinet rear panel, set filter box circuit breaker to OFF, and swing logic chassis out.
2. Refer to Figure 6-1 and loosen four retaining rods securing filter.
3. Raise metal chamber on top of filter and slide filter clear of cabinet.
4. Install replacement filter (P/N 94301100) by reversing above steps.
5. Make certain that all seams (gasket foam) are tight and will not allow air to bypass filter.

CORRECTIVE MAINTENANCE

The maintenance procedures for the DSU are provided on the basis of the subassemblies of the unit. Detailed procedures (Check, Adjustment, Removal and/or Replacement) are provided as subparagraphs to the subassembly heading.

CAUTION

Care must be used when handling a disk pack around a unit with its top cover open. Erasure of data on the pack will occur if the pack gets closer than three inches to the magnet assembly.

It is recommended that maintenance personnel read the entire procedure prior to performing the instructions of the procedure.

Procedures requiring oscilloscope connections to be made in the logic chassis assume that the front and/or rear covers of the chassis have been removed.

READ/WRITE HEADS

Head/Arm Adjustment

1. Stop spindle motor and set DC circuit breaker to OFF.
2. Open top cover.

3. Set WRITE INHIBIT switch to up position (the READ ONLY indicator shall light).

CAUTION

The CE disk pack contains specially recorded tracks of data. Extreme care must be taken so that this data is not modified.

NOTE

To eliminate unnecessary head alignment, use the same CE pack that was previously used to perform this procedure.

4. Install CE pack. Avoid contacting the index-sector transducer.
5. Units with EKXV card in location A16: If the DSU had been working with multiple sector packs, remove card in location A16 and set switches on card to single sector per instructions in Section 3 of this manual.
6. Ground A09-30A to deselect head 0, which is always selected.
7. Set DC circuit breaker to ON.

NOTE

The disk pack must be temperature stabilized before continuing the procedure. Pack must be stored in same environment as DSU for the 60-minute period immediately preceding performance of this procedure.

8. Start spindle motor; allow pack to reach operational speed.

NOTE

On units with PC card switches set for multiple sectored packs up to speed will not be reached when a CE pack is used. To overcome this, step 9 must be followed.

9. Ground A16-28B to A16-34A after brush cycle starts.

NOTE

It is necessary to position heads to a specific track location in the following step. This command may be derived by a field test unit or applicable in-line diagnostic procedure and controller (refer to controller CE manual).

10. Position carriage to cylinder 146. Release spring latch to lock carriage in area of cylinder 146. (Spring latch is located just behind read/write heads on disk cleaner side of carriage.)
11. Connect oscilloscope external trigger to test point D (Index) at location A16.
12. Connect oscilloscope channels A and B to test points G and F of card at location F01 (on deck). Ground oscilloscope at test point A of same card.
13. Connect jumper between test point of head tested and ground point Y or R of same head select card (card location E01 for even numbered heads). Heads are numbered from top downward, 00 through 19.

NOTE

Since one revolution of disk pack equals 24 ms, the oscilloscope horizontal time base must be placed in the uncalibrated position in order to achieve the waveforms of Figure 6-3.

14. Adjust oscilloscope sweep so that three cross-over points (nulls) span exactly 10 centimeters (Figure 6-3).
15. Note whether center cross-over is within 0.5 cm of the center graticle. If it is, proceed to step 19, if it is not, loosen the clamp screw on the head/arm clamp assemblies immediately above and below the head being checked.
16. Refer to Figure 6-4 and place slot in end of head adjustment tool over head/arm assembly so that tips of tool enter carriage groove and bottom of tool slot engages head/arm notch.

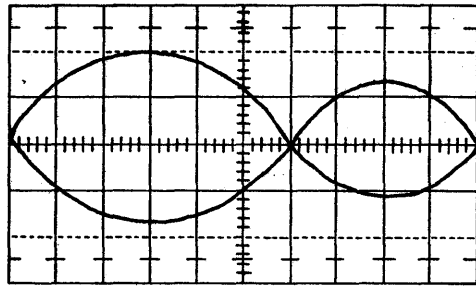

A HEAD POSITIONED TOO FAR FROM SPINDLE

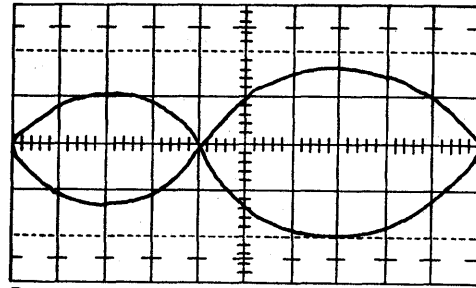

B HEAD POSITIONED TOO CLOSE TO SPINDLE

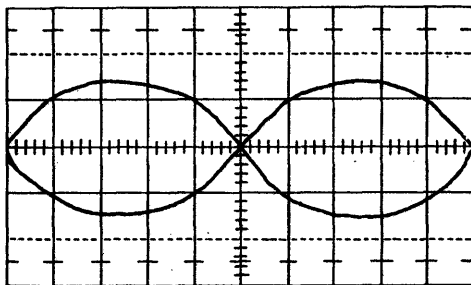

C HEADS ON TRACK

ALL TRACES
 HOR - 2 MS/CM, UNCAL.
 VERT - 0.5 V/CM

7F28C

Figure 6-3. Head Adjustment Trace

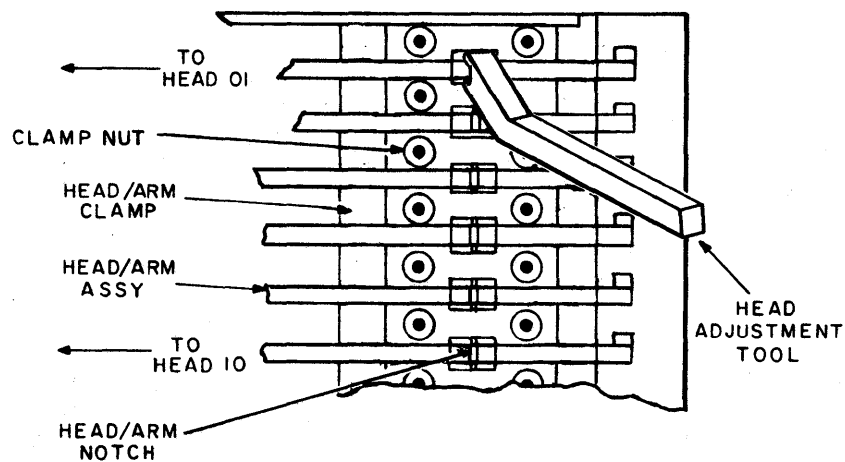

Figure 6-4. Head/Arm Assembly Adjustment

NOTE

Very little tool motion is required to make the following adjustment.

17. Moving tool laterally (parallel to head/arm length), reposition head/arm until center cross-over point displayed on oscilloscope is within ± 0.2 cm of center vertical graticule.
18. Remove adjustment tool and carefully torque clamp screws above and below head to 5 ± 1 inch-pounds. Position established in step 15 must remain in tolerance. Readjust if required.
19. Repeat steps 13 through 18 for read/write heads immediately above and below head just adjusted.
20. Repeat steps 13 through 19 for any other head requiring adjustment.
21. Disengage spring latch securing carriage and return latch to holding bracket.
22. Stop spindle motor.
23. Remove CE pack. Avoid contact with index transducer.
24. Disconnect oscilloscope.
25. Set DC circuit breaker to OFF.
26. Remove card at A16 and set switches to original configuration.
27. Remove ground jumpers installed in steps 6 and 9.



Head/Arm Removal and Replacement

1. Stop spindle motor.
2. Set AC power circuit breaker to OFF.
3. Open cabinet pack access cover.
4. Remove disk pack. Avoid contact with index transducer.
5. Release spring latch so as to restrict carriage forward motion during the following procedure.
6. Refer to Figure 6-5 to determine location of faulty head/arm assembly. Disconnect related head plug at card E01 or F02.
7. Remove clamp screw securing hold down clamp against faulty head/arm assembly (Figure 6-5 and Table 6-1) using tools 12218425 and 87016703. Set screw and hold down clamp aside.

TABLE 6-1. READ/WRITE HEAD REPLACEMENT DATA

Read/Write Head/Arm No. (See Figure 6-5)	Read/Write Head Replacement Part No.
(All even numbered heads) (All odd numbered heads)	Refer to decal on Magnet assembly for head part numbers.

ARROWHEAD POINTS IN
DIRECTION OF HEAD
MOTION DURING LOADING

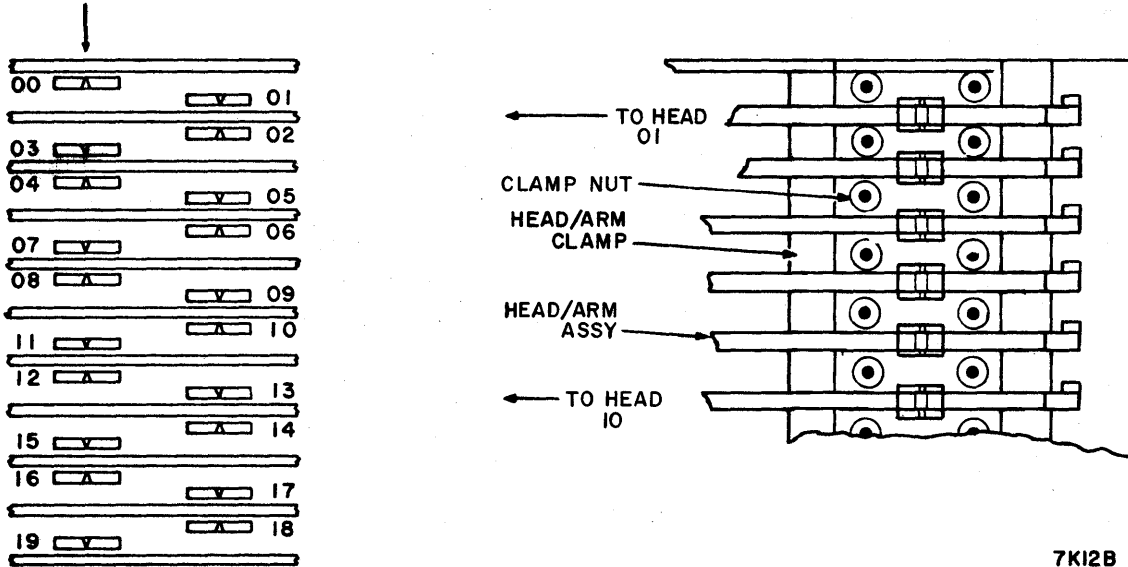

7KI2B

Figure 6-5. Head Arm Replacement

CAUTION

Observe the following cautionary instructions during the remainder of this procedure (Figure 6-6).

Do not touch the read/write head face. Damage to the related gimbals may result.

Use only the minimum force required when overriding the assembly's tendency to unflex. Unnecessary force can make the assembly unuseable.

Use care when installing or removing an assembly. If the assembly is allowed to unflex rapidly, it may cause damage to itself and/or an adjacent assembly.

Keep all contact with adjacent heads to a minimum. This will save realignment time later.

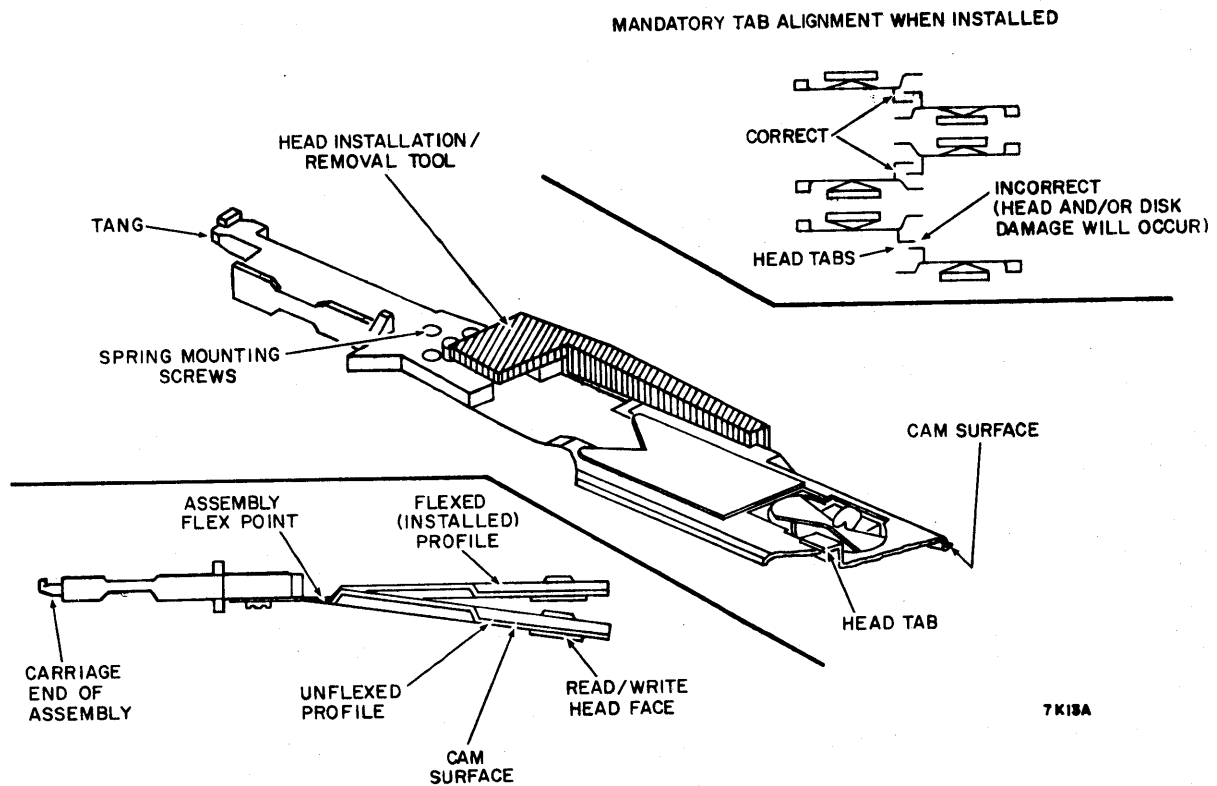

Figure 6-6. Head/Arm Installation or Removal

8. Grasp head end (avoid read/write head face) between thumb and forefinger of hand and move assembly away (up or down) from related cam surface.
9. Keep assembly off cam while working carriage end of assembly free. When it is free, hold both ends securely and keep the assembly straight while withdrawing it from the carriage and the cam mount. Set faulty head aside.
10. Start the carriage end of the replacement assembly toward the carriage. Keep contact with the assemblies above and below to a minimum. When the end starts to enter the carriage notch, simultaneously raise head cam surface onto cam while applying pressure at the flex point to straighten the head. With pressure still applied at the flex point engage the carriage end of the assembly with receiving slot.
11. Visually align free end of assembly with those assemblies above and below.

12. Connect head plug at card E01 or F02 as applicable.
13. Inspect replaced assembly. Make certain that head cable is oriented similarly to other adjacent cables.

NOTE

Make certain that clamp bar is contacting the outer edge of both head/arm assemblies before tightening the clamp screws.

14. Assemble hold down clamp over head (Figure 6-5). Secure hold down clamp and head with clamp screw. Use tools 12218425 and 87016703 to tighten clamp screw to 5 ± 1 in.-lbs.
15. Replace cable clamp assembly.
16. Disengage spring latch and return it to the holding bracket.
17. Perform Head/Arm Adjustment procedure on replaced head and heads immediately above and below it.
18. Perform Adjacent Track Erase Check procedure on replaced head.
19. Perform Index to Burst Check and Adjustment procedure.

Adjacent Track Erase Check

It is necessary to perform this check only on a read/write head that has been replaced.

NOTE

In the following procedure it is necessary to position the heads to specific track locations and write data on the disk pack. These commands may be derived by a field test unit or the applicable in-line diagnostic (refer to controller CE manual for procedure).

1. Position the carriage to cylinder 404.
2. Write a data pattern of all ones with the read/write head that was replaced.
3. Open cabinet top cover.
4. Connect channels of oscilloscope (to add and invert channel B) to test point F and G of SPL card at location F01 for all heads. Ground oscilloscope at test point R or Y of same card.
5. Connect oscilloscope external trigger to A16-tpk (Index) at logic chassis back panel (if unit is a multi-sectored pack, trigger oscilloscope).
6. Select head (of step 2) for a Read operation. Observe oscilloscope trace amplitude. Record amplitude.
7. Position carriage to cylinder 403. Write data pattern of all ones with head from step 2.
8. Position carriage to cylinder 405. Write data pattern of all ones with head from step 2.
9. Position carriage to cylinder 404.
10. Select the head for Read operation. Observe oscilloscope trace amplitude. Amplitude must be at least 85 percent of the amplitude recorded in step 6.
11. If the read/write head fails any of the above requirements, replace it.

Tuned Amplifier Check and Adjustment

1. Install disk pack and load heads (insure this is not a CE pack).

NOTE

In the following procedure it is necessary to position the heads to specific track locations and write an all ones pattern on the disk pack (perform a read while doing this procedure). These commands may be derived by a Field Test Unit or the applicable In-Line diagnostic (refer to Controller CE Manual for procedure).

2. Set POWER ON switch to START and allow unit to reach speed.
3. Record all "1's" on data pattern.
4. Sync position on internal channel 1.
5. Connect channel 1 to test point B on A08 (10X Probe). Adjust variable capacitor (at top of PCB) for maximum amplitude at test point B (See figure 6-8).
6. Select add mode. Connect channel 1 to test point D and channel 2 to test point F on A08.
7. Adjust Data Window Adjust (at bottom of PCB) on A08 to center pulse at test point F within the pulse on test point D. See Figure 6-7.

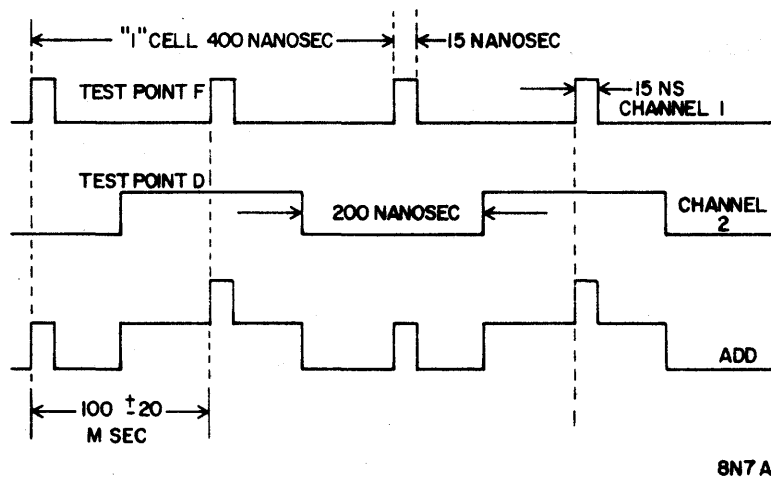

Figure 6-7. Symmetry Adjustment

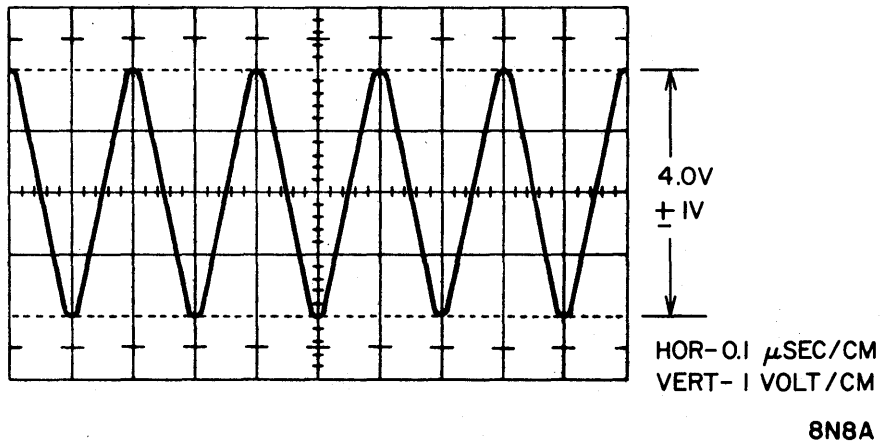

Figure 6-8. Read Oscillator Output Waveform

Figure Deleted

Figure 6-9.

DRIVE BELT REMOVAL AND REPLACEMENT (Figure 6-10)

1. Open cabinet front door and set AC circuit breaker to OFF.
2. Open cabinet rear door. Release logic chassis latch and swing logic chassis out. Disable spindle lock mechanism by closing front cover.
3. Place replacement drive belt close at hand.
4. Disconnect connector from pack-on switch. Disconnect spindle ground strap from deck.
5. Remove ratchet brake linkage assembly from sector sensor positioner shaft and from the machine.
6. Move motor and brake assembly forward to the limit of the slots in the motor mounting plate (override idler spring force).
7. Drop drive belt from spindle drive pulley. Raise other end of belt clear of drive motor pulley.
8. Install replacement belt (smooth side of belt against pulleys) first on the spindle pulley and then around the drive motor pulley. The motor and brake assembly must be moved forward when installing the belt on the motor pulley.
9. Allow idler spring to pull on motor and brake assembly. Manually turn the spindle about ten revolutions to center belt on pulleys.
10. Restore electrical connections of step 4.
11. Position ratchet brake linkage assembly on sector sensor shaft so brake pawl locks detent plate with front cover open 70° , and unlocks with cover open 45° . Tighten in position. With cover closed, check for clearance shown in Figure 6-10 detail C.
12. Swing logic chassis in and close front and rear doors.

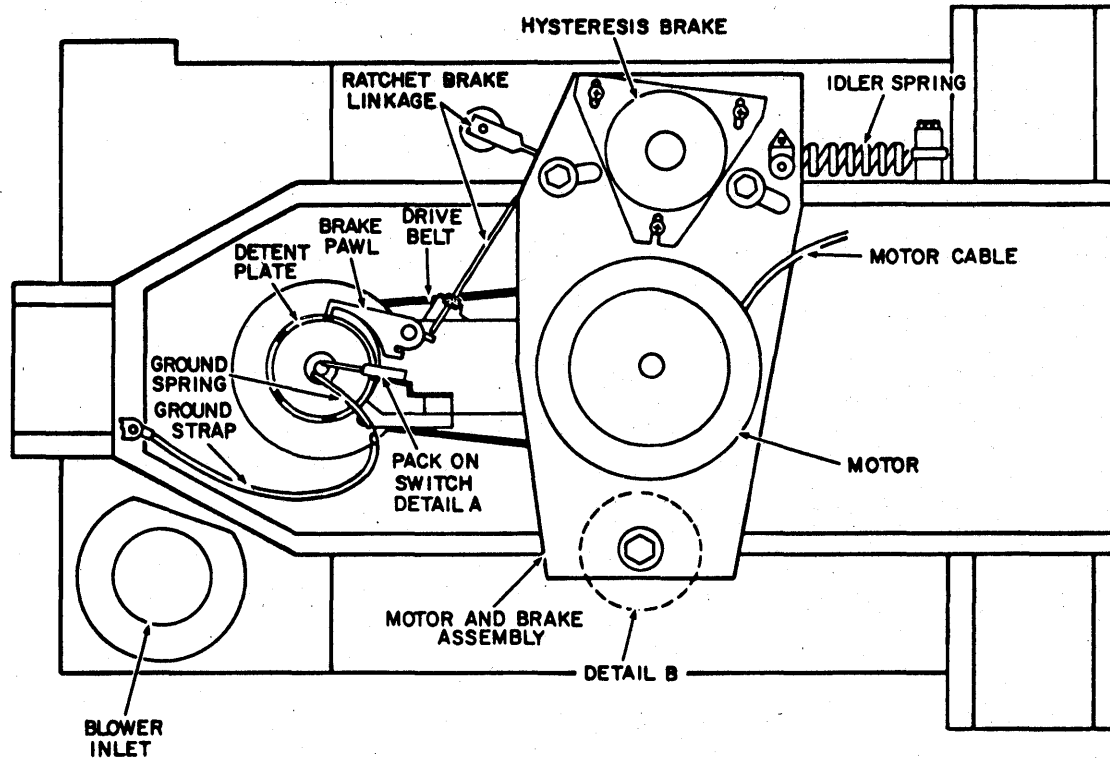

PACK ON SWITCH
DETAIL A

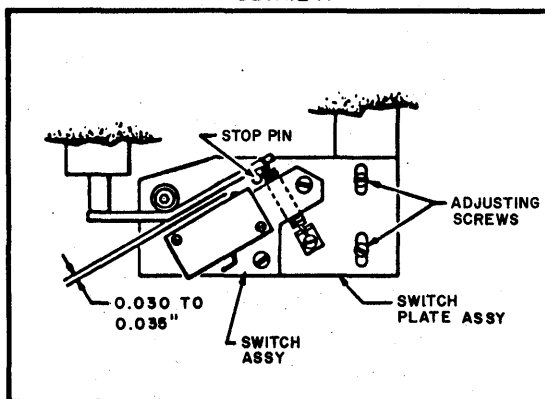

MOTOR BRAKE
ASSEMBLY MOUNTING
DETAIL B

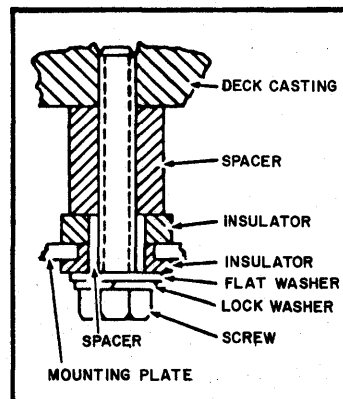

RATCHET BRAKE
DETAIL C

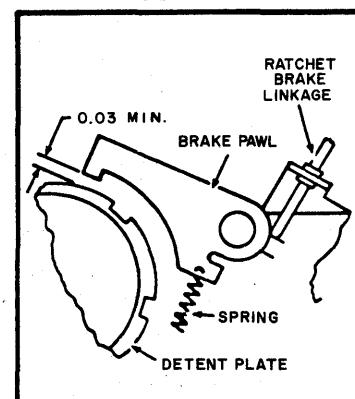

7T23A

Figure 6-10. Main Deck Underside

DRIVE MOTOR REMOVAL AND REPLACEMENT (Figure 6-10)

The drive motor is not field repairable. If trouble is experienced, replace it and return faulty unit to the factory.

1. Open cabinet front door.
2. Set AC power circuit breaker to OFF.
3. Open rear door and swing logic chassis out.
4. Disconnect drive motor cable plug and hysteresis brake cable plug.
5. Remove drive belt from motor pulley by moving motor and brake assembly forward and raising belt clear of pulley. Allow belt to remain around spindle. Disconnect idler spring and allow to hang from opposite end.
6. Support motor and brake assembly and remove three screws securing assembly to underside of deck.
7. Lower assembly clear of deck and remove from cabinet.
8. Loosen three screws securing brake plate to motor plate so as to relieve tension on V-belt.
9. Loosen setscrews and remove drive pulley (Figure 6-11) from faulty motor.
10. Loosen setscrews and remove V-belt pulley from faulty motor.
11. Remove four screws and washers and separate motor from motor mounting plate.
12. Align motor cable exit point to motor mounting plate according to Figure 6-10. Secure replacement motor to mounting plate.
13. Install V-belt pulley on motor shaft establishing required dimension (Figure 6-11) between bottom of pulley and top of motor mounting plate. Secure pulley to shaft with setscrews using one drop of Loctite, Grade C, on setscrew threads. Torque setscrews to 75 ± 5 in-lbs.
14. Set drive motor pulley (Figure 6-11) on motor shaft and allow it to slide down and contact V-belt pulley.
15. Apply one drop of Loctite, Grade C, to setscrew threads. Use setscrews to secure drive motor pulley to motor shaft. Torque setscrews to 75 ± 5 in-lbs. Torque setscrew on keyway first and then setscrew on motor shaft.

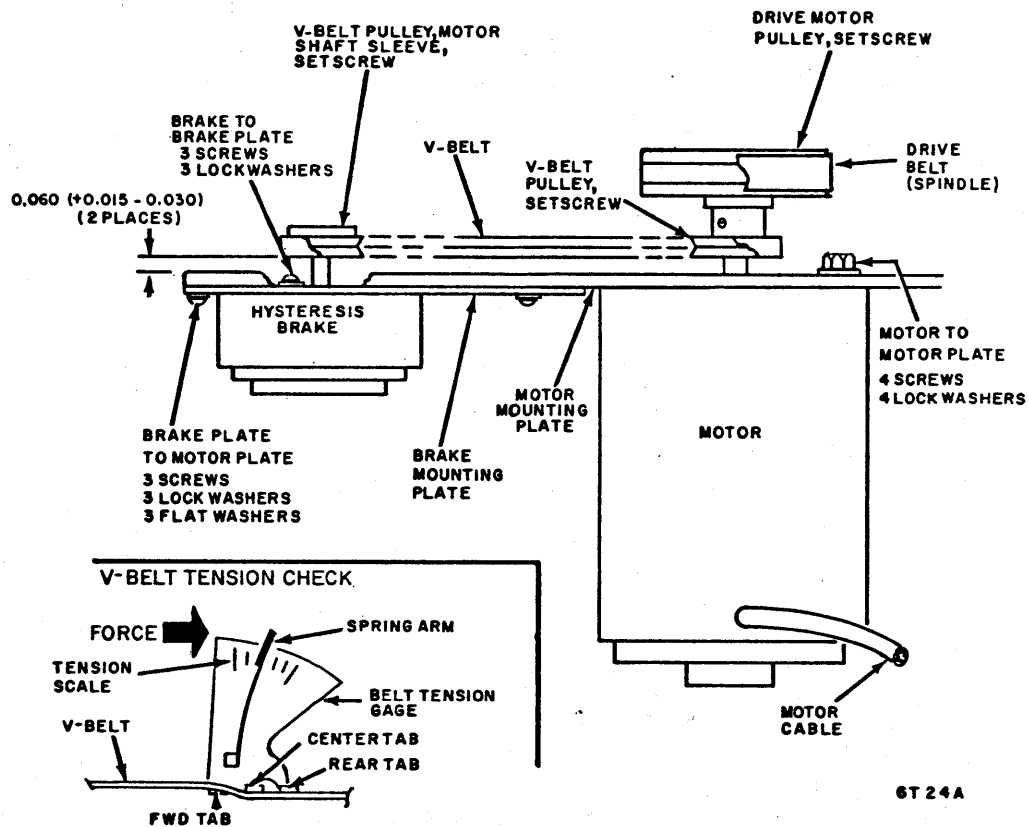

6T 24A

Figure 6-11. Motor and Brake Assembly

16. Place V-belt over brake and motor V-belt pulleys.
17. Slide brake plate away from motor to establish moderate belt tension. Tighten screws securing brake plate to motor plate.
18. Place V-belt between forward and center tabs of belt tension gage (P/N 84267100) according to Figure 6-11. Use finger to press gage spring arm until rear tab just contacts belt. Spring arm must be at 14 (+2, -0) pounds on tension scale as rear tab contacts belt. Reposition brake mounting plate until requirement is met.
19. Raise motor and brake assembly toward underside of deck. Secure assembly to deck with three screws (Figure 6-10, detail B).
20. Place drive belt around spindle pulley and motor pulley so that the smooth side of belt is against the pulleys.

21. Connect idler spring to post on motor mounting plate (Figure 6-10).
22. Connect drive motor cable plug and hysteresis brake cable plug.
23. Close logic cabinet and both doors.

DRIVE MOTOR PULLEY REMOVAL AND REPLACEMENT (Figure 6-11)

1. Open cabinet front door and set AC circuit breaker to OFF.
2. Open cabinet rear door. Release logic chassis latch and swing chassis out.
3. Disconnect drive motor cable plug and hysteresis brake cable plug.
4. Move motor and brake assembly forward (against idler spring force).
5. Raise belt clear of drive motor pulley (Figure 6-11).
6. Allow drive belt to remain around spindle pulley.
7. Loosen setscrews securing drive motor pulley to motor shaft and remove faulty pulley.
8. Apply one drop of Loctite, Grade C, to threads of setscrews.
9. Check that required dimension exists between bottom surface of V-belt pulley on motor shaft and top surface of motor mounting plate, Figure 6-11. If requirement is not met, loosen V-belt pulley setscrews, reposition pulley along shaft. Apply one drop of Loctite, Grade C, to setscrew threads. Torque setscrews to 75 ± 5 in-lbs.
10. Set replacement pulley on motor shaft (Figure 6-11) allowing it to slide down and contact V-belt pulley.
11. Use setscrews of step 9 to secure pulley to motor shaft. Torque setscrews to 75 ± 5 in-lbs. Torque setscrew on keyway first and then setscrew on motor shaft.
12. Place drive belt around spindle pulley and motor pulley so that the smooth side of belt is against the pulleys.
13. Connect drive motor cable plug and hysteresis brake cable plug.
14. Set AC circuit breaker to ON.
15. Close logic cabinet and both doors.

HYSTERESIS BRAKE OR BELT REMOVAL AND REPLACEMENT (Figure 6-11)

1. Open cabinet front door.
2. Set AC power circuit breaker to OFF.
3. Open rear door and swing logic chassis out.
4. Disconnect drive motor cable plug and hysteresis brake cable plug.
5. Move motor and brake assembly forward (against idler spring force).
6. Raise belt clear of drive motor pulley.
7. Allow drive belt to remain around spindle pulley.
8. Loosen three screws securing brake plate to motor plate so as to relieve tension on V-belt.
9. Replace V-belt according to step 10. Replace hysteresis brake according to step 11.
10. Replace V-belt as follows:
 - a. Raise old belt clear of pulleys.
 - b. Loop replacement belt around pulleys.
 - c. Proceed to step 12.
11. Replace hysteresis brake as follows (Figure 6-11):
 - a. Remove setscrew securing V-belt pulley and motor shaft sleeve to brake shaft.
 - b. Remove three screws and washers securing faulty brake to brake plate.
 - c. Install replacement brake on brake plate with three screws and washers.
 - d. Assemble V-belt pulley (with motor shaft sleeve in hub) to brake shaft. Using a setscrew with one drop of Loctite, Grade C on threads, establish the dimension specified in Figure 6-11 between the pulley and motor mounting plate and secure the pulley and sleeve to the shaft.
 - e. Loop V-belt around V-belt pulleys.
12. Slide brake away from motor to establish moderate belt tension. Tighten screws securing brake plate to motor plate.

13. Place V-belt between forward and center tabs of belt tension gage (P/N 84267100) according to Figure 6-11. Use finger to press gage spring arm until rear tab just contacts belt. Spring arm must be at 14 (+2, -0) pounds on tension scale as rear tab contacts belt. Reposition brake mounting plate until requirement is met.
14. Place drive belt around spindle pulley and motor pulley so that the smooth side of belt is against the pulleys.
15. Connect drive motor cable plug and hysteresis brake cable plug.
16. Close logic cabinet and both doors.

SPINDLE LOCK PAWL

Check (Figure 6-10)

1. Open cabinet front door.
2. Open rear door and swing logic chassis out.
3. Check brake pawl tip clearance (Figure 6-10, detail C) with front cover closed; then check that spindle is free with front cover 45° open, and locked with cover 70° open.
4. Perform the adjustment procedure if requirement of step 3 is not met.
5. Close logic cabinet and both doors.

Adjustment (Figure 6-10)

1. Loosen screw securing ratchet brake linkage to bottom end of sector sensor positioner shaft (shaft protruding through deck).
2. Position ratchet brake linkage assembly on sector sensor shaft so brake pawl locks detent plate with front cover open 70°, and unlocks with cover open 45°. Tighten in position. With cover closed, check for clearance shown in Figure 6-10, detail C.
3. Swing logic chassis in; close front and rear doors.

PACK-ON SWITCH

Check and Adjustment (Figure 6-11)

1. Open cabinet front door.
2. Remove right side panel.
3. With no pack on spindle, check for 0.030 to 0.035 clearance between actuator arm and stop pin. Adjust by loosening two adjusting screws and repositioning switch plate assembly.
4. Place pack on spindle, rotating pack handle clockwise until switch contacts transfer (audible).
5. Check for 0.005 to 0.010 clearance between actuator arm and stop pin. Adjust by loosening two screws in switch adjustment bracket and rotating switch as necessary.
6. Replace right side panel.
7. Close front door.

Removal and Replacement (Figure 6-10)

1. Open cabinet front door.
2. Remove right side panel.
3. Disconnect switch wires at connector P322.
4. Remove two screws, washers, and the switch.
5. Install replacement switch, screws, and washers.
6. Reconnect wires to switch at connector P322.
7. Adjust switch (see Check and Adjustment procedure).
8. Install right side panel.
9. Close front door.

GROUND SPRING CHECK AND ADJUSTMENT

1. Remove left side panel.
2. Insert 0.005 non-metallic feeler gage between ground spring and spindle shaft.
3. Attach push-pull gage (P/N 12210797) to extreme free end of ground spring and pull, noting force to release feeler gage.
4. If force was not 3.53 to 5.30 ounces, loosen spring mounting block attachment screws and reposition block; tighten mounting block screws.
5. Repeat steps 3 and 4 until requirement is met.
6. Install left side panel.

SPINDLE AND LOCKSHAFT ASSEMBLY

CAUTION

If lockshaft is recessed into spindle cone it is possible that the snap ring is broken. If this condition exists do not attempt any spindle or lockshaft disassembly. The broken snap ring would allow the lockshaft to be expelled under great force when the retaining nut is removed. Under these circumstances the entire spindle and lockshaft assembly should be replaced.

Field repair of this assembly is limited to replacing the lockshaft. If the trouble being experienced cannot be remedied by replacing the lockshaft, replace the entire spindle and lockshaft assembly. Return the faulty assembly to the factory.

Lockshaft Removal and Replacement

1. Remove left and right side panels.
2. Open cabinet front door.
3. Disconnect pack-on switch wires at connector P322.
4. Disconnect ground strap from deck.
5. Remove two screws and two washers securing pack-on switch assembly to switch mount.

6. Remove two screws and two washers securing ground spring mount assembly to switch mount.
7. Open cabinet front cover and turn spindle until brake pawl engages detent plate.
8. Remove the lock nut and stop washer from the lower end of the lockshaft.



9. Carefully raise lockshaft out of top of spindle assembly.
10. Lower replacement lockshaft into top of spindle assembly.

CAUTION

Installed lockshaft must move freely without binding on internal spring.

11. Install stop washer and lock nut on lower end of lockshaft.
12. Tighten lock nut to a torque of 20 inch-pounds minimum.
13. Reassemble remaining components to spindle by reversing steps 3 through 6.
14. Perform Pack-On Switch Check and Adjustment procedure.
15. Perform Ground Spring Check and Adjustment procedure.
16. Install left side and right side panels.
17. Close front door and cover.

Spindle and Lockshaft Assembly Removal and Replacement

1. Open cabinet front cover.
2. Remove nine screws from bottom of shroud.
3. Close cabinet front cover and open cabinet top cover.
4. Remove two screws from shroud outside left flange.
5. Disconnect rubber tube at disk cleaner cover.
6. Remove disk cleaner cover and retaining screw.
7. Lift shroud from deck and set aside.
8. Remove screw, flat washer, lock washer, and clamp half securing thermo compensation tube to spindle.
9. Loosen clamp securing thermo compensation tube to stationary segment of transducer, and rotate tube to a vertical position.
10. Open front door.
11. Open rear door and swing logic chassis out.

12. Remove left side and right side panels.
13. Remove ratchet brake linkage assembly (Figure 6-10) by loosening screw on linkage arm.
14. Disconnect pack-on switch at connector P322 (Figure 6-10).
15. Disconnect ground strap from deck.
16. Force motor and brake assembly forward (against idler spring force) and remove drive belt from drive motor pulley. Allow belt to fall below spindle.
17. Remove four nuts and eight washers from screws securing spindle assembly to deck. Remove the four screws.
18. Close cabinet top cover and open front cover.

CAUTION

Do not pry on spindle mounting surface of the deck.

19. Using a screwdriver, pry spindle up and off of the two roll pins that locate it on the deck. Two pry surfaces are provided directly below the spindle surface and forward of the roll pins.
20. Lift spindle assembly from deck being careful not to damage the lockshaft or ratchet brake as the spindle comes through the deck hole.
21. Remove ratchet brake assembly from faulty spindle assembly and install it on replacement spindle assembly. Allow brake pawl to engage detent plate notch and then tighten screws securing brake to spindle.
22. Place replacement spindle on deck being careful not to damage the lockshaft or the ratchet brake assembly when lowering the assembly through the deck.

CAUTION

Tighten the spindle down evenly over the roll pins keeping the spindle surface parallel to the mating deck surface.

23. Close cabinet front cover and open cabinet top cover.
24. Replace four bolts, eight washers, and four nuts. Tighten this hardware evenly so that the spindle flange and deck flange are kept parallel to each other.

25. Rotate thermo compensation tube down to spindle and install screw, flat washer, lock washer, and clamp half.
26. Position thermo compensation tube so transducer flex mounting springs are visually perpendicular to the fixed portion of the transducer, then tighten screw holding tube to spindle (Figure 6-12).

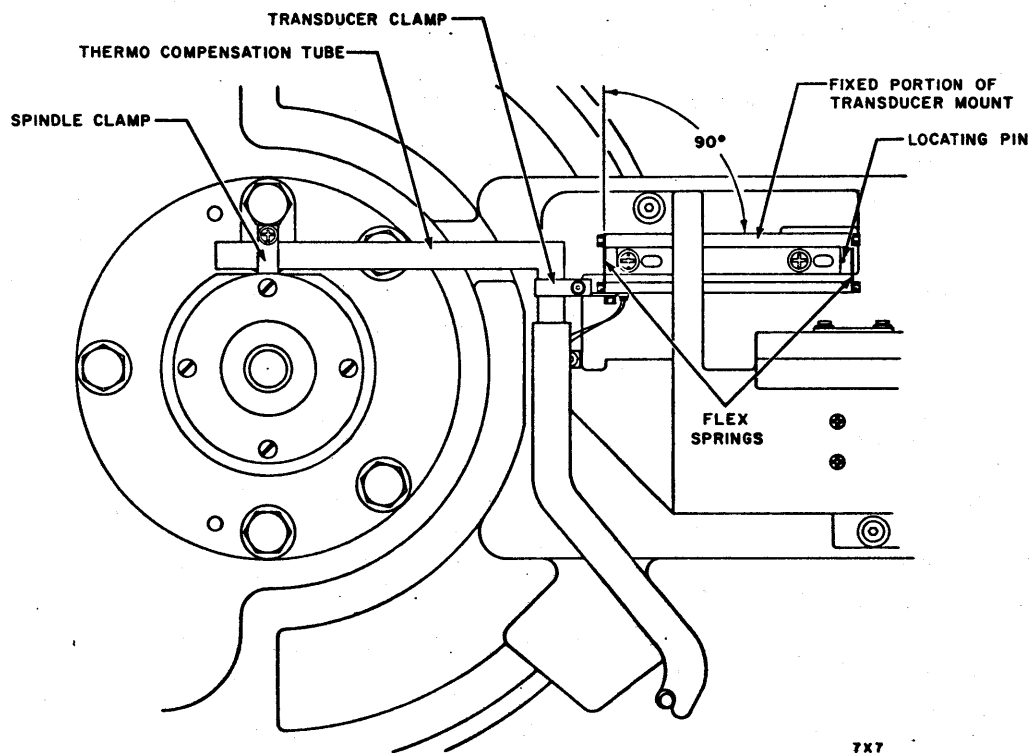

Figure 6-12. Fixed Transducer and Thermo Compensation Tube Installation

27. Carefully align transducer clamp and thermo compensation tube, then tighten clamp screw, making sure clamp and transducer are parallel.
28. Perform steps 6 through 16 of Position Transducer Check. ✓
29. Install shroud, reversing the operations in steps 2 through 6.
30. Perform Carriage Alignment procedure. ✓

31. Perform Ground Spring Check and Adjustment procedure.
32. Perform Pack-On Switch Check and Adjustment procedure.
33. Perform Head/Arm Adjustment procedure.
34. Perform Index to Burst Check and Adjustment procedure.
35. Perform Spindle Lock Pawl Check and Adjustment procedure.
36. Perform Shroud Adjustment procedure.
37. Install left side panel and right side panel.
38. Swing logic chassis in and close rear door.
39. Close front door.

INDEX-SECTOR SENSOR ASSEMBLY

Sensor Stop Check and Adjustment

1. Stop spindle motor.
2. Open cabinet front cover.
3. Remove disk pack from spindle. Avoid contact with index-sector transducer.
4. Remove nine screws securing shroud to deck.
5. Close cabinet front cover and open top cover.
6. Remove two screws from shroud outside left flange.
7. Disconnect rubber tube at disk cleaner cover and lay aside.
8. Remove disk cleaner cover and retaining screw.
9. Raise shroud clear and set aside.
10. Close cabinet top cover and open front cover. Install CE disk pack (P/N 89259000) on spindle. Avoid contact with index-sector transducer.
11. Open cabinet top cover. Manually rotate disk pack. Stop rotation when edge of sector disk is nearest the inner vertical surface of sector block (Figure 6-13).

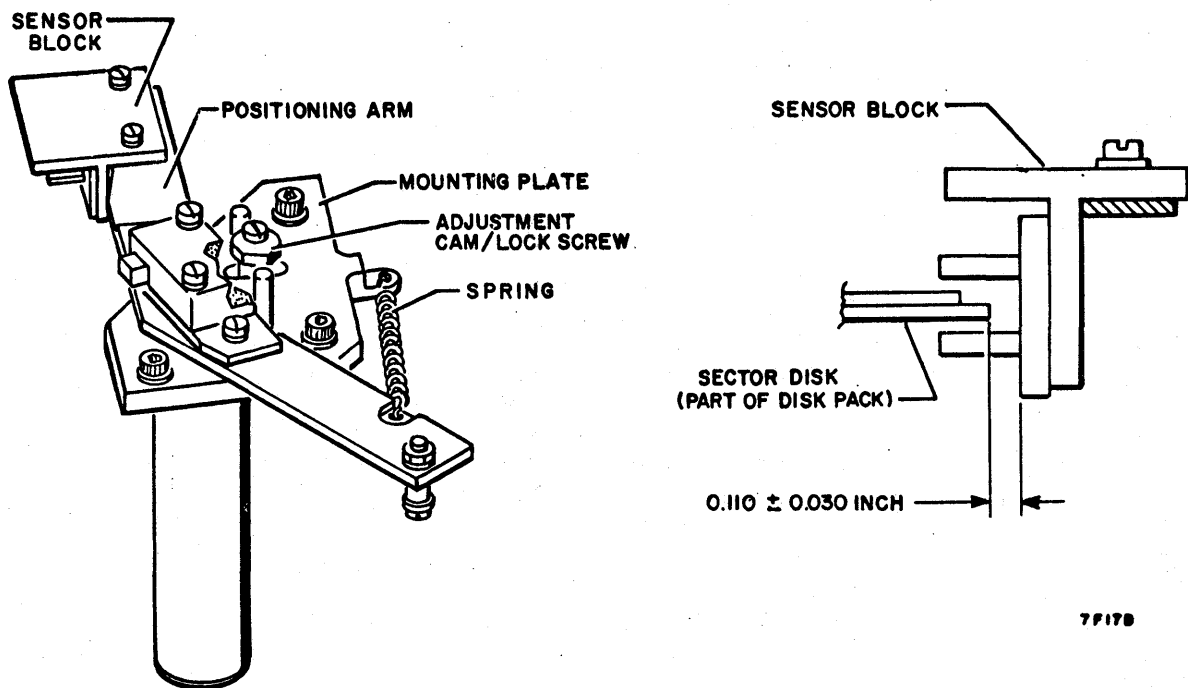

Figure 6-13. Index-Sector Sensor

12. Measure gap between adjacent edge of sector disk and sector block surface. The gap must be 0.110 ± 0.030 inch (Figure 6-13). Adjust as follows:
 - a. Loosen two screws securing sector block to positioning arm.
 - b. Reposition sector block on positioning arm until proper dimension is achieved.
 - c. Tighten screws securing sector block and recheck gap. Readjust if required.
13. Remove CE disk pack from spindle. Avoid contact with index transducer.
14. Install shroud, reversing steps 4 through 10.
15. Perform Shroud Adjustment procedure.
16. Remove disk pack.

Index to Burst

1. Stop spindle motor.
2. Set DC circuit breaker to OFF.
3. Open cabinet top cover.
4. Set WRITE INHIBIT switch to up position. Read only indicator shall light.

CAUTION

The CE disk pack contains specially recorded tracks of data. Extreme care must be taken so that this data is not modified.

5. Check hub of CE pack for presence of Label specifying Index to data period. If label is found, make a note of value specified.
6. Install CE disk pack. Avoid contact with index-sector transducer.
7. Ground A09-30A to A09-34A (deselect all heads).
8. Set DC circuit breaker to ON.
9. Start spindle motor.

NOTE

On units with PC card switches set for multiple sectored packs, up to speed will not be reached when a CE pack is used. To overcome this, step 10 must be followed.

10. Ground A16-28B to A16-34A (Plug, PA16 located at this position must go into plug) after brush cycle starts (pulls K5 relay).

NOTE

It is necessary to position heads to a specific track location in the following procedure. This command may be derived by a field test unit or the applicable in-line diagnostic (refer to controller CE manual for procedure).

11. Position carriage to cylinder 236.
12. Select head 9 by connecting a jumper wire between test point 9 (Figure 6-18) and convenient logic ground of card at location E01 (on deck).

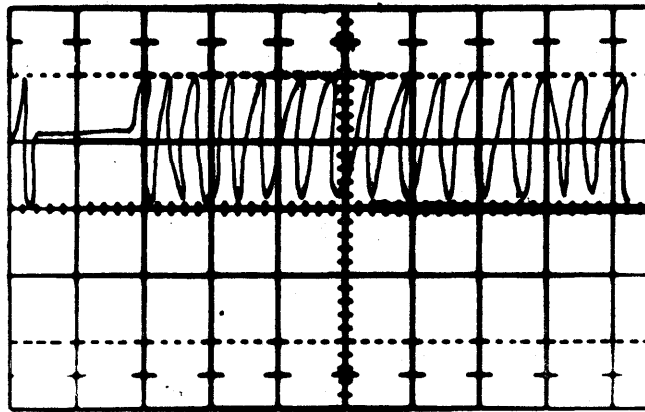

TPD AT A16
 HOR-10 μ SEC/CM
 VERT-2V/CM

6T61A

Figure 6-14. Detector Trace

13. Connect oscilloscope positive external trigger to test point D (Index) of card at location A16 or A16-21B.
14. Connect oscilloscope channels A and B to test points G and F card at location F01 (on deck). Ground oscilloscope at test point A of same card.
15. Refer to Figure 6-15 for oscilloscope settings. Compare traces. Period between Index pulse and peak of first Data pulse must be as follows: 3 μ sec (± 3) if no label was found on deck pack hub, or as specified on disk pack hub. If requirement is not met, adjust as follows:
 - a. Loosen three screws securing Index/Sector sensor mounting plate to deck (Figure 6-13).
 - b. Loosen lockscrew in adjustment cam. Rotate adjustment cam clockwise or counterclockwise until requirement for period (step 13) is met.
 - c. Tighten screws (Phillips first) securing mounting plate to deck. Be careful not to change period adjustment.
 - d. Tighten lockscrew in adjustment cam.
 - e. Check the period and readjust if required.

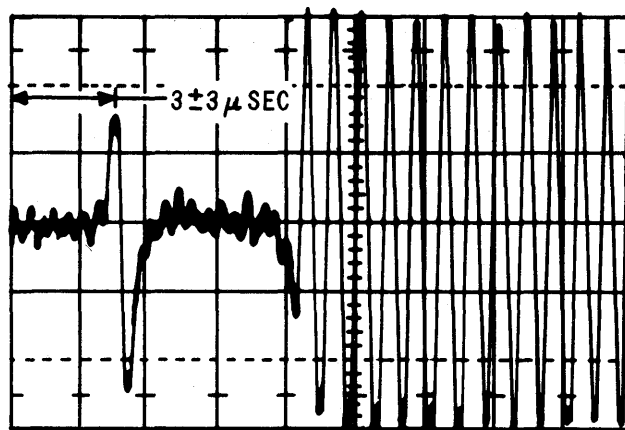

HOR-2 μSEC/CM
 VERT-1V/CM

6T60A

Figure 6-15. Index to Burst Period

16. Disconnect oscilloscope external trigger. Set triggering to internal.
17. Disconnect channel probes.
18. Connect channel A probe to test point D (Index) of card at location A16.

NOTE

Switches 44 and 42 apply only to units with EKV card.

19. Trace must indicate a logic "1" (+3 V) pulse with a width of 55.0 (±8.25) μsec (Figure 6-14) with Switches 44 and 42 open. If requirement is not met, a failure has occurred in term Y404. With Switches 44 and 42 closed pulse width is 2.5 μsec.
20. Disconnect oscilloscope.
21. Remove ground jumpers installed in steps 7 and 10.
22. Stop spindle motor and remove CE disk pack. Avoid contact with index transducer.

Index Transducer Removal and Replacement

1. Stop spindle motor.
2. Open cabinet front door and set AC circuit breaker to OFF.
3. Open cabinet front cover. Remove disk pack from spindle
4. Remove nine screws securing shroud to deck.

5. Close front cover and open cabinet top cover.
6. Disconnect rubber tube at brush cover, remove one screw holding disk cleaner cover and remove cover.
7. Remove two screws from shroud outside left flange.
8. Raise shroud clear of deck and set aside.
9. Disconnect sensor block cable plug and cut cable ties securing cable to positioning arm.
10. Remove two screws and washers securing sensor block assembly to positioning arm (Figure 6-13). Remove assembly from deck area.
11. Install replacement sensor block assembly by reversing steps 9 and 10. Position the sensor block as far away from spindle as slots will allow. Make certain that sensor block leadwires are secured to positioning arm with new cable ties.
12. Perform steps 10 through 13 of the Sensor Stop Check and Adjustment procedure.
13. Perform Index to Burst Check and Adjustment procedure.
14. Install shroud reversing the operations in steps 4 through 7.
15. Set AC circuit breaker to ON.
16. Close top cover and rear door.

Transducer Output Check

1. Open cabinet front cover and install disk pack.
2. Close cabinet front cover.
3. Open cabinet rear door. Connect oscilloscope channel probe to wire wrap pin 27B at location A16. Ground oscilloscope at test point A of card at location A16.
4. Set oscilloscope trigger to internal and negative.
5. Make oscilloscope settings according to Figure 6-16.
6. Start spindle motor and allow heads to load.
7. Examine trace for agreement with requirements of Figure 6-16.

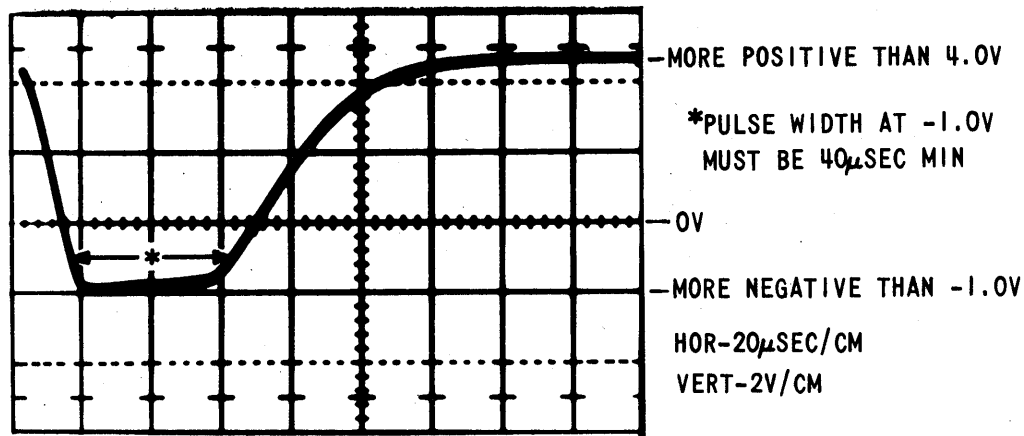

6T62

Figure 6-16. Index-Sector Transducer Trace

8. If any requirement is not met, replace the index transducer.

SHROUD ADJUSTMENT

1. Make certain that nine screws in bottom of shroud and two screws on input air duct flange are loose enough to allow shroud to be positioned laterally.
2. Install disk pack.
3. Visually inspect clearance between entire circumference of disk pack sector disk and adjacent interior surface of shroud.
4. If clearance is uniform, remove disk pack from spindle. Tighten eleven screws in shroud. Make certain shroud does not shift from established position.
5. If clearance is not uniform, adjust as follows:
 - a. Position shroud laterally to meet requirement of step 3.
 - b. Remove disk pack from spindle.
 - c. Tighten eleven screws in shroud, making certain that shroud does not shift from original position.

DISK CLEANER ASSEMBLY

Check (Figure 6-17)

1. Open cabinet top cover.
2. Remove disk cleaner cover and attaching screw.
3. Using feeler gauge, make certain that dimensions A and B (Figure 6-17) are a minimum of 0, 010 inch as brushes reach limits of their travel.
4. Using multimeter, check that continuity (0 ohms on meter) exists between brush switch (S301) posts 2 and 3 with brushes retracted. Meter must indicate infinity between posts 1 and 3 with brushes in this position.
5. With brushes extended, continuity must exist between switch posts 1 and 3. No continuity should exist between posts 2 and 3.
6. Perform adjustment procedure if required.
7. Install disk cleaner cover and attaching screw.

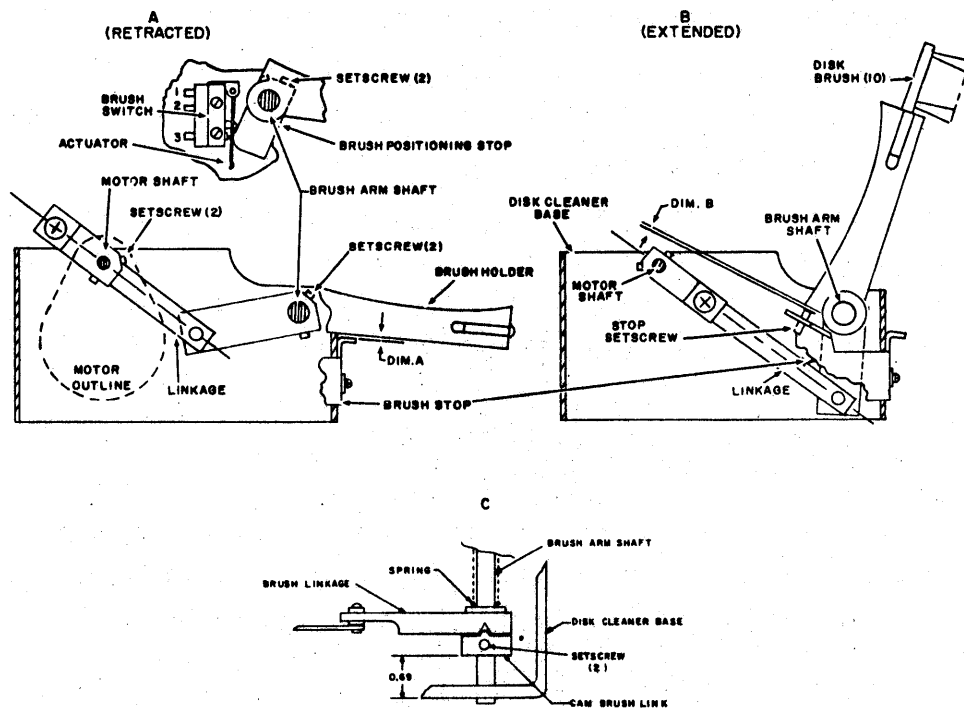

6T26

Figure 6-17. Disk Cleaner Adjustment

Adjustment (Figure 6-17)

Unless otherwise specified, brushes must follow linkage movement (brush detenting mechanism engaged).

1. Make certain brush assembly detent mechanism is engaged (brushes follow movement of linkage).
2. Loosen two setscrews securing linkage to motor shaft and two setscrews securing cam brush link to brush arm shaft.
3. Set brush holder against brush stop with detent mechanism engaged. Align linkage according to part A, Figure 6-17. Tighten two setscrews securing linkage to motor shaft. Adjust dimension between cam brush link and disk cleaner base according to part C, Figure 6-17. Tighten two setscrews in cam brush link.
4. Loosen two screws securing brush stop. Place 0.020-inch shim or feeler gauge between lower brush holder and brush stop (dimension A, Figure 6-17). Remove slack in linkage by pressing brush stop toward brush holder and tighten two screws securing brush stop.
5. Align linkage according to part B, Figure 6-17. Using a shim or feeler gauge, turn stop setscrew to establish a 0.020-inch gap (dimension B, Figure 6-17) between stop setscrew and brush holder.
6. Align linkage according to part A, Figure 6-17. Loosen two setscrews securing brush positioning stop. Rotate brush positioning stop against brush switch actuator until switch clicks. Rotate brush positioning stop an additional 2 or 3 degrees and tighten both setscrews.

Removal and Replacement (Figure 6-17)

No special instructions are required for removal and replacement except, when replacing motor or switch, use 2 drops of Loctite, Grade C, on threads of each securing screw. Perform check procedure following any replacement.

POSITION TRANSDUCER OSCILLATOR CHECK

1. Connect oscilloscope probe to wire wrap pin 9B of card at location A20.
2. Oscillator output voltage must be 2.0 ± 0.3 volts peak-to-peak.
3. Period of one complete sinewave must be 20 ± 1 usec (50 kHz nominal).
4. Connect oscilloscope probe to wire wrap pin 7B of card at location A20.
5. Oscillator output voltage must be 14.0 volts peak-to-peak (minimum).

HEAD SELECT PREAMPLIFIER CARD REMOVAL AND REPLACEMENT

1. Stop spindle motor.
2. Open cabinet front door and set AC circuit breaker to OFF.
3. Open cabinet top cover. Remove head cable clamp assembly.
4. Disconnect each head cable plug connected to edge of card at locations E01 and F02 (Figure 6-18)

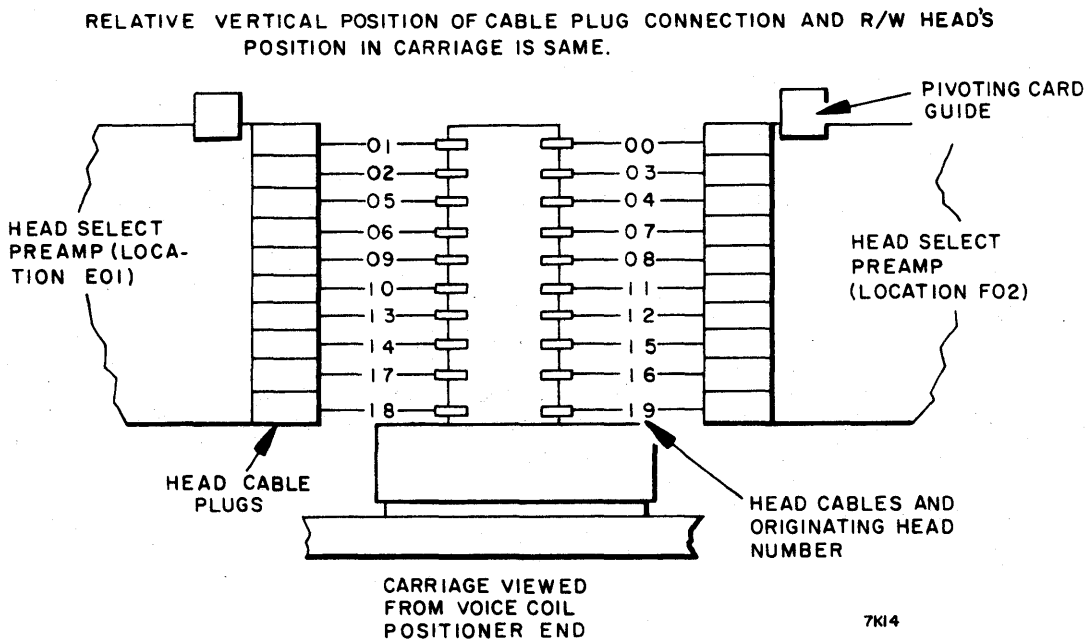

Figure 6-18. Read/Write Head Cable Connections

5. Remove two wing studs at front of preamplifier card chassis and rotate chassis clear of carriage.
6. Carefully extract card from chassis by pulling card straight away from connector.
7. Install replacement card carefully so that connector pins are not damaged.
8. Rotate preamplifier chassis into place and secure with two wing studs.

NOTE

Head cables should not cross. Plug of top read/write head connects to top position on edge of card at E01; plug of bottom read/write head connects to bottom position on edge of card at F02.

9. Connect head cable plugs to edge of head select preamplifier cards (Figure 6-18) and replace head cable clamp assembly.

HEADS LOADED SWITCH

Check

1. Stop spindle motor.
2. Open cabinet front door and set AC circuit breaker to OFF.
3. Open cabinet top cover.
4. Remove disk pack.

NOTE

Switch transfer may be monitored by listening for an audible click or by connecting a multimeter across the switch leadwire terminals.

5. Retract carriage to retracted stop.

6. Advance carriage until switch S300 clicks and check distance traveled. If necessary, loosen switch and adjust to achieve 0.180 - 0.260 inches travel.
7. Retract carriage from switch transfer point in step 6 above until second click is heard. Replace switch if distance traveled exceeds 0.150 inches.
8. Replace disk pack and close front cover.
9. Set AC circuit breaker to ON and close front door.

Removal and Replacement

No special instructions are required for removal and replacement except, when replacing switch, use one drop of Loctite, Grade C, on threads on each screw securing switch to mounting bracket. Perform Heads Loaded Switch Check procedure following any replacement.

VELOCITY TRANSDUCER

Check

NOTE

It is necessary to position heads to a specific track location in the following procedure. This command may be derived by a field test unit or the applicable in-line diagnostic (refer to controller CE manual for procedure).

1. Install a disk pack.
2. Open cabinet rear door. Connect oscilloscope channel probe to test point C (velocity integrator) of card at location A17.
3. Connect oscilloscope external trigger to test point 15A (T \leq 32) of card at location A12. Set triggering for positive.
4. Connect oscilloscope ground to GRD jack on logic chassis maintenance panel.
5. Set oscilloscope horizontal to 2 ms/cm and vertical to 2 v/cm.

6. Start unit and allow heads to load. Command a 405-cylinder continuous seek.

NOTE

The oscilloscope displays the velocity integrator saw-tooth (ramps) output for 31 of the last 32 cylinders of the seek. The positive ramps occur at the end of a forward seek; the negative ramps are related to the reverse seek.

7. The last positive ramp and the last negative ramp must have an amplitude of 2.7 ± 0.3 volts. The absolute values of the two amplitudes must agree to within ± 0.35 volts maximum.
8. If the above requirements are not met, perform the Integrator Gain Check/Adjustment procedure, then repeat this procedure. If requirements are still not met, replace velocity transducer.

Removal and Replacement (Figure 6-19)

1. Open cabinet front door and set AC circuit breaker to OFF.
2. Open cabinet top cover.
3. Refer to Figure 6-19 and disconnect plug P304.
4. Remove two screws and washers securing velocity transducer end cap to rear surface of magnet assembly. Retain cap, screws and spring (located inside cap).

CAUTION

Use care throughout following procedures so that extension rod does not get bent.

5. Use a pliers to unthread extension rod at the point it enters the rear of the head/arm receiver.
6. Carefully pull transducer magnet and extension rod out of the end cap end of transducer coil/housing.
7. Pull transducer coil/housing from magnet assembly.

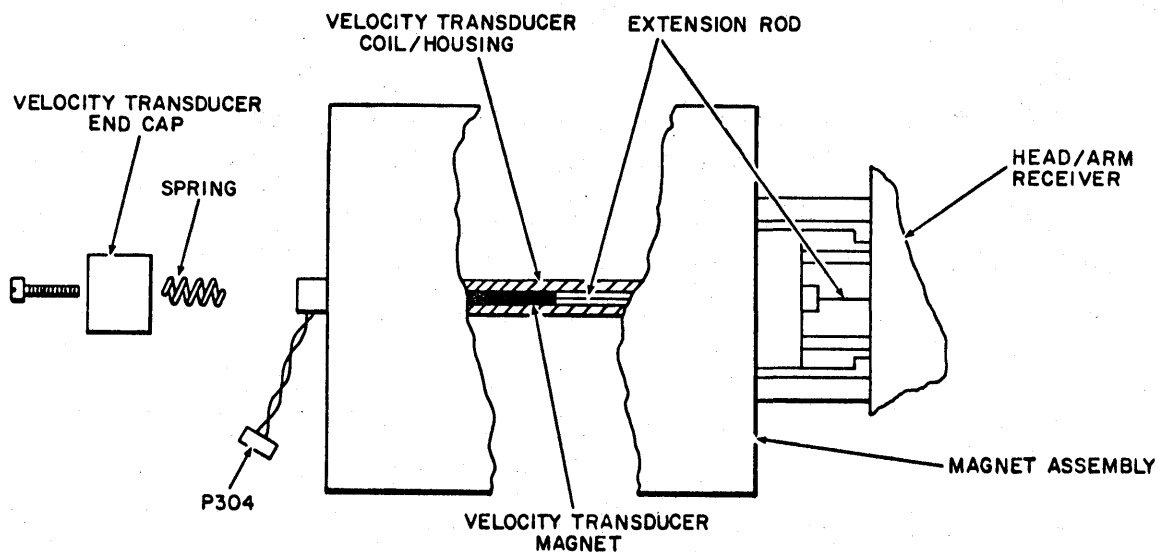

7K15

Figure 6-19. Velocity Transducer Replacement

8. Carefully unthread extension rod from transducer magnet. Moderate force may be required since Loctite was used on rod threads.

CAUTION

The magnet in the replacement velocity transducer may be rendered unuseable if it is allowed to touch a metal object. Keep it in shipping container until it is to be installed.

9. Slide replacement transducer coil/housing into magnet assembly.
10. Observing the earlier caution, carefully remove replacement transducer magnet from shipping container.
11. Grasp transducer magnet securely and carefully insert one end of it into coil/housing bore. Determine which end of transducer magnet is attracted into bore. This is the end in which the extension rod must be installed in the next step. Note the end and return magnet to shipping container.
12. Apply 1 drop of Loctite, Grade C, to the extension rod threads that mate with transducer magnet. Thread rod into proper end of replacement magnet. Tighten with fingers only.

13. Carefully insert free end of extension rod into bore of coil/housing. Slide assembly into bore until threads of extension rod are visible behind head/arm receiver.
14. Apply 1 drop of Loctite, Grade C, to extension rod threads. Use a pliers and only moderate force to install extension rod tip in head/arm receiver.
15. Manually move carriage forward until transducer magnet is fully received into coil/housing bore.
16. Assemble spring and transducer end cap to rear surface of magnet assembly using two screws and washers.
17. Connect plug P304.
18. Perform Velocity Gain Check/Adjustment procedure.
19. Perform Integrator Gain Check/Adjustment procedure.
20. Perform Velocity Transducer Check procedure.
21. Set AC circuit breaker to ON and close cabinet front door.

CARRIAGE ALIGNMENT

A carriage assembly is properly aligned when carriage motion is along a radial line to the spin axis of the spindle assembly. The following adjustment is required whenever the five screws securing the actuator mounting plate to the deck casting are loosened, or the spindle assembly is loosened from the deck casting.

1. Refer to Head/Arm Removal and Replacement procedure (steps 1 through 10) and remove head/arm assembly 09.
2. Close top cover and open front cover.
3. Remove nine screws from base of shroud.
4. Disconnect rubber tube at brush cover.
5. Remove screw holding disk cleaner cover and remove cover.
6. Remove two screws from outside left shroud flange.
7. Raise shroud clear of deck and set aside.

8. Install carriage alignment arm (P/N 87350900) on carriage at the head 09 position. Tighten head/arm clamps and alignment arm in place.
9. Install carriage alignment ring (P/N 87351000) on spindle cone.

CAUTION

Read/write heads must be clean to prevent damage during the following operations. There is no requirement to protect heads if reasonable care is used. Protective pads or the use of other foreign materials may only introduce contaminants to the heads. Never touch a head face with fingers.

10. Inspect read/write heads and clean them, if necessary, according to the procedures in the Preventive Maintenance section of this manual.
11. Slowly extend carriage until carriage alignment arm and ring are aligned approximately as shown in Figure 6-20.

NOTE

The actuator mounting plate pivots on a pin located beneath and to the rear of magnet assembly. Pivoting motion is tangential to the spindle and can occur only if the five screws securing the mounting plate to the deck are loose.

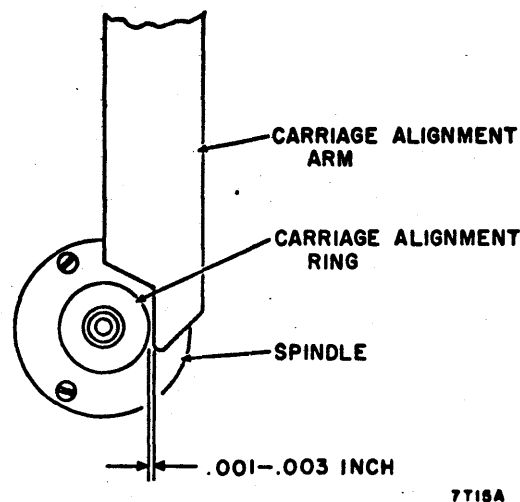

Figure 6-20. Carriage Alignment

12. Check that clearance between ring and arm tools is as specified in Figure 6-20.
13. If adjustment is required, loosen five screws in mounting plate and establish required clearance between tools. Carefully and evenly tighten screws. Recheck clearance and readjust if required.
14. Refer to Head/Arm Removal and Replacement procedure and install head 09.
15. Install shroud on deck, reversing the operations in steps 3 through 8.
16. Perform Shroud Adjustment procedure.
17. Perform Head/Arm Adjustment procedure.
18. Perform Index to Burst Check and Adjustment procedure.

POSITION TRANSDUCER

Output Check

1. Install disk pack.
2. Open top cover and front door.
3. Start unit and allow heads to load.
4. Set power supply $\pm 36V$ circuit breaker to OFF.
5. Ground oscilloscope at GND jack on logic chassis maintenance panel.
6. Connect oscilloscope channel probe to test point E (Even winding) on position transducer preamplifier card, located on main deck.
7. Open cabinet rear door.
8. Release logic chassis latch and swing chassis out.
9. Connect oscilloscope external trigger to wire wrap pin 7B (50 kHz oscillator) of card at location A20. Set horizontal time base to 10 $\mu\text{sec/cm}$.
10. Manually move carriage between cylinders 0 and 405.

NOTE

Note that the signal goes through a series of high points (peaks) and low points (nulls) as the carriage is moved between cylinders 0 and 405.

11. Locate the maximum amplitude high point and record the peak-to-peak amplitude (should be 9 (± 1.5) volts).
12. Locate the minimum amplitude high point and record the peak-to-peak amplitude (should be 9 (± 1.5) volts).
13. Apply the values recorded in steps 11 and 12 to the following formula:

$$\frac{\text{max high point amp.} - \text{min point amp.}}{\text{min high point amp.}} \leq 15\%$$

14. Manually move carriage and record the high point amplitude near cylinders 0 and 405. The high point amplitude near cylinder 405 must be within ± 6 percent of amplitude near cylinder 0.
15. Disconnect oscilloscope channel probe at test point E of position transducer preamplifier card and connect it to test point B (Odd winding) of preamplifier card.
16. Manually move carriage and examine trace amplitudes for a small number of cylinders (4 or 5) near cylinder 0.
17. The observed amplitudes must agree with the value recorded in step 14 (near cylinder 0) to within ± 5 percent.
18. If requirements of steps 11 through 14 and 17 are not met, go to adjustment.
19. Set power supply ± 36 V circuit breaker to ON.
20. Close top cover and open front cover.
21. Install disk pack.
22. Start unit and allow heads to load.

Adjustment

1. Depress Start/Stop switch to extinguish indicator Start switch.
2. Open pack access cover.
3. Remove disk pack.
4. Remove 9 screws from bottom of shroud.

5. Close front cover and open top cover.
6. Disconnect the rubber tube at the brush cover.
7. Remove retaining screw and disk cleaner cover
8. Remove two screws in outside left shroud flange.
9. Lift shroud from deck and set aside.
10. Set power supply ± 36 V circuit breakers to OFF.
11. Remove yellow voice coil lead on deck.
12. Use a 0.002-inch plastic feeler gage to check that movable segment of transducer is flush to locating pins (two on the top and one on the side). Feeler gage should not go between the transducer and guide pins. Refer to Figure 3-14.
13. If requirement of step 12 is not met, loosen the two screws securing the moveable segment of transducer to carriage. Apply pressure upward and toward the rear on the transducer and carefully tighten the two screws.
14. Repeat step 12.
15. Loosen screw that secures the thermo compensation tube to the spindle.
16. Loosen the clamp that secures the thermo compensation tube to the stationary segment of the transducer.
17. Loosen the two screws securing the stationary segment mounting block (leave screws snug).
18. Use screwdriver inserted in adjustment slots on mounting block to obtain a 0.004-inch gap between the adjacent faces of position transducer pieces (Figure 3-14). Tighten screws securing mounting block.
Recheck parallelism of two transducer pieces.
19. Position thermo compensation tube so that flex mounting springs are visually perpendicular to the fixed portion of the transducer, then tighten screw holding tube to spindle.

20. Carefully align the thermo compensation tube and transducer clamp, then tighten clamp screw, making sure that clamp and transducer are parallel and below deck surface.
21. Recheck parallelism of two transducer pieces.
22. Repeat steps 8 through 18, of Output Check.
23. Manually retract carriage.
24. Install yellow voice coil lead on deck.
25. Set power supply ± 36 V circuit breakers to ON.
26. Stop spindle motor.
27. Remove disk pack, avoiding contact with index transducer. Close pack access cover and open top cover.
28. Install shroud, reversing the operations of steps 4 through 9.
29. Perform Shroud Adjustment procedure.
30. Align mechanical vernier track indicator to read 0 after a RTZ command.
31. Remove oscilloscope heads.
32. Close front door and front cover.



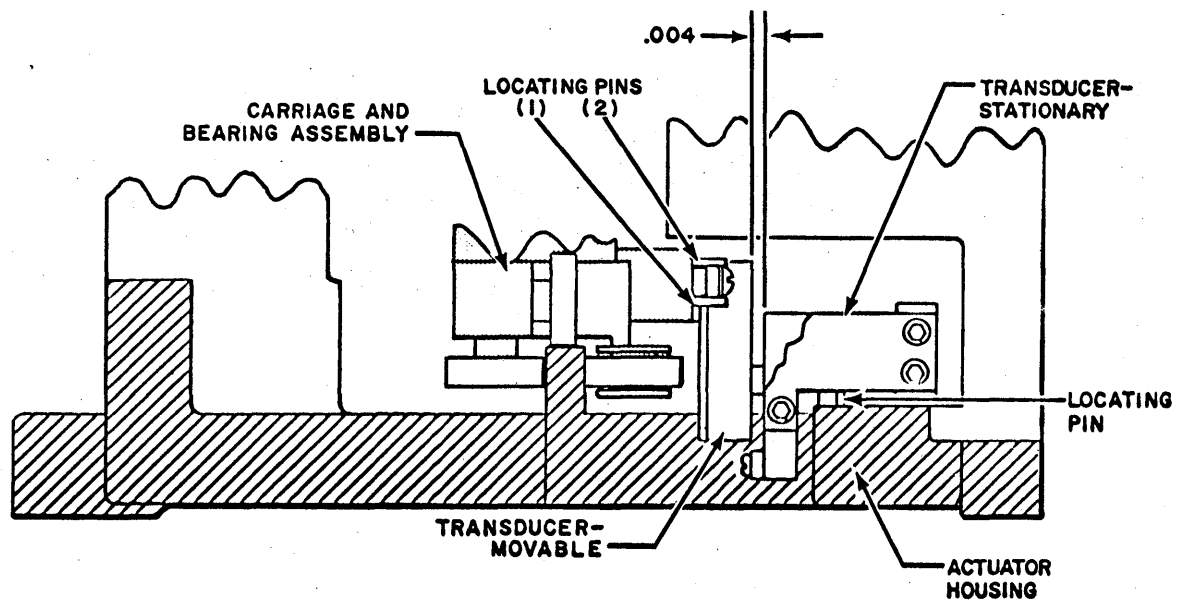

Figure 6-21. Position Transducer

TK16B

Removal and Replacement of Stationary Segment

1. Stop spindle motor.
2. Open cabinet pack access cover.
3. Remove disk pack. Avoid contact with index transducer.
4. Set AC circuit breaker to OFF.
5. Remove nine screws from shroud base.
6. Close front cover and open top cover.
7. Remove two screws from outside left shroud flange.
8. Remove attaching screw and disk cleaner cover.
9. Lift shroud from deck and set aside.
10. Remove screw securing thermo compensation tube to spindle.
11. Remove screws securing stationary segment.

12. Disconnect plug P-300 and remove stationary segment from actuator.
13. Remove cable and thermo compensation tube from faulty segment and connect to new segment. Connect leadwires as follows:

<u>Transducer terminal</u>	<u>Leadwire color</u>
1	yellow
2	black

14. Manually position carriage and movable transducer opposite location of fixed transducer.

NOTE

After installation, fixed transducer flex springs must visually be at right angles to transducer bars, and transducer segments must not contact each other.

15. Install replacement fixed transducer on actuator using both screws, positioning transducer against locating pin and a 0.004 shim held in front of movable transducer (Figure 6-12).
16. Carefully reposition carriage and movable transducer at several points along fixed transducer, checking clearance with shim.
17. Install screw, flat and lock washers, clamp and thermo compensation tube tightly on spindle, maintaining 90° angle of flex springs.
18. Close top cover.
19. Set AC circuit breaker to ON.
20. Perform Position Transducer Output Check procedure, steps 1 through 17. If the requirements of steps 11 through 14 and 17 in that procedure are not met, go to step 21.
21. Perform Head/Arm Adjustment procedure (for each head).
22. Open top cover.
23. Install shroud, reversing operations of steps 5 through 8.

24. Perform Shroud Adjustment procedure.
25. Close front cover.

Removal and Replacement of Movable Segment

1. Stop spindle motor.
2. Remove disk pack. Avoid contact with index transducer.
3. Set AC circuit breaker to OFF.
4. Open cabinet top cover.
5. Remove two screws securing movable segment to carriage.
6. Disconnect four twisted pair leadwire connections to faulty transducer.
7. Make four twisted pair leadwire connections to replacement transducer as follows:

<u>Transducer Terminal</u>	<u>Twisted Pair Color</u>	<u>Card Connector</u>	<u>Transducer Terminal</u>	<u>Twisted Pair Color</u>	<u>Card Connector</u>
1	black	6	5	black	1
2	red	5	6	red	2
3	white	9	7	white	3
4	green	8	8	green	4

8. Place one drop of Loctite, Grade C, on threads of screws to be used to secure transducer to carriage.
9. Position replacement transducer segment against carriage (Figure 6-20). Use two screws prepared in step 8 to secure transducer to carriage (do not tighten). Slide the segment toward magnet and upwards against locating pins. Tighten screws.
10. Carefully move carriage forward while observing adjacent faces of position transducer. Make certain that they do not contact or rub against each other.
11. Perform Position Transducer Check procedure.
12. Perform Head/Arm Adjustment procedure (for each head).

DC OFFSET CHECK

1. Open cabinet front cover.
2. Install a disk pack and close front cover.
3. Start unit and allow heads to load.
4. Using a voltohmmeter, measure the voltage at wire wrap pin 12A, 12B, 11B, 13A, 13B of card at location A17. The voltage test point must be 0.0 ± 0.2 volts dc.
5. If the requirement is met, go to step 6. If requirement is not met, proceed as follows:
 - a. Stop unit and allow heads to unload, then start unit and allow heads to load.
 - b. Repeat step 4.
 - c. If requirement of step 4 is still not met, troubleshoot logic related to test point not meeting requirement.
6. Use a oscilloscope to check the voltage at test point B of card A17. Ground oscilloscope at test point A or Z of same card. Oscilloscope must indicate 0 ± 20 mv. If requirement is met, check is complete. If requirement is not met, replace card at A17.

VELOCITY GAIN CHECK/ADJUSTMENT

NOTE

The waveforms shown in Figure 6-22 will vary with the unit temperature. Therefore, to provide an accurate check, this procedure must be performed with the unit at ambient temperature. Do not perform this procedure unless the card has been replaced or the unit is not meeting access timing requirements.

1. Open cabinet front cover. Install a disk pack and close front cover.
2. Start unit and allow heads to load.
3. Open cabinet rear door.
4. Connect oscilloscope external trigger to test point A11-13A (FWD SEEK) Trigger may be set for either positive or negative.
5. Connect channel A of oscilloscope to wire wrap pin 32B (On Cylinder) at location A12.
6. Connect channel B of oscilloscope to test point F (Current Sense) at location A17.
7. Set both channels to Chop mode.

NOTE

It is necessary to position heads to a specific track location in the following procedure. This command may be derived by a field test unit or the applicable in-line diagnostic (refer to controller CE manual for procedure).

8. Command unit to perform a 300 cylinder continuous seek between cylinders 0 and 300.
9. Make oscilloscope sensitivity settings according to Figure 6-22.

NOTE

Figure 6-22 is representative only of seeks commanded by the access tester. Seeks commanded by the controller show a center ON CYLINDER pulse approximately 24 ms long and a current sense near ground during the same period.

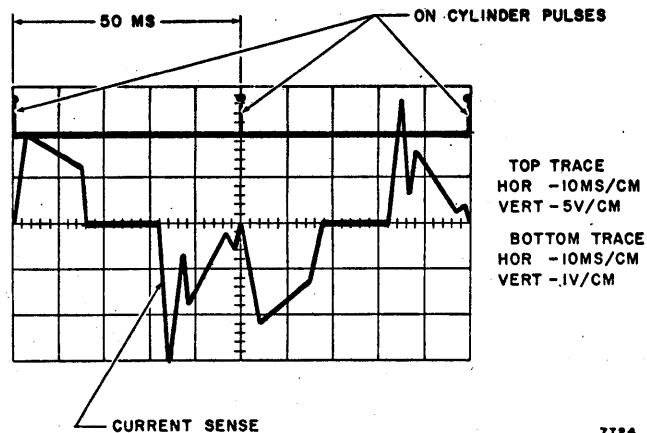

Figure 6-22. Velocity Gain Adjustment
(Access Tester Seeks Only)

10. Compare the resulting trace to Figure 6-22. If the trace meets the requirement of the figure, disconnect oscilloscope; check is complete.
11. If requirement is not met, adjust 5K potentiometer shaft on card at location A17 (bottom pot of card) until trace and figure agree. Disconnect oscilloscope.

FINE POSITION GAIN CHECK/ADJUSTMENT

1. Open cabinet front cover. Install a disk pack and close front cover.
2. Start unit and allow heads to load.
3. Open rear door and remove logic chassis covers.
4. Connect oscilloscope external trigger to pin 9A (Any Seek) at location A11. Set trigger to positive.
5. Connect oscilloscope ground lead to GND test point A or Z of a logic card, or a convenient logic ground on back panel.

6. Connect one channel of oscilloscope to test point C (Fine Position Signal) at location A20. Set horizontal sensitivity to 1 ms/cm and vertical sensitivity to 2 v/cm.
7. Connect other oscilloscope channel to test point E (On Cylinder Delay) at location A12.
8. Set both channels to Chop mode.

NOTE

In following procedure it is necessary to command seek operations. These commands may be derived by either suitable software and the central processor or by a field test unit. If command is derived from central processor, use a sequential read so as to keep unit on cylinder at each cylinder for about 25 ms.

9. Command a one cylinder sequential forward seek (405 cylinder forward, one trace at a time) from cylinder 0.

NOTE

Each of the 405 movements constitutes a seek operation. A trace will occur for each seek. If variations appear in trace characteristics, they will occur gradually as the unit moves from one track to the next. Failure to meet a requirement will generally be preceded by a trend in that direction.

10. Make trace comparison with Figure 6-23, part A for each of the 405 seek operations.
11. If requirements are met, disconnect oscilloscope; check is complete.
12. If requirements are not met, adjust as follows:
 - a. Command a one cylinder sequential forward seek from cylinder 0.

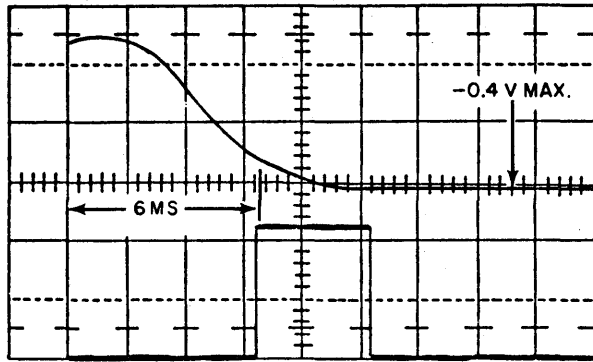

A CORRECT

HOR —1MS/CM
VERT —2V/CM

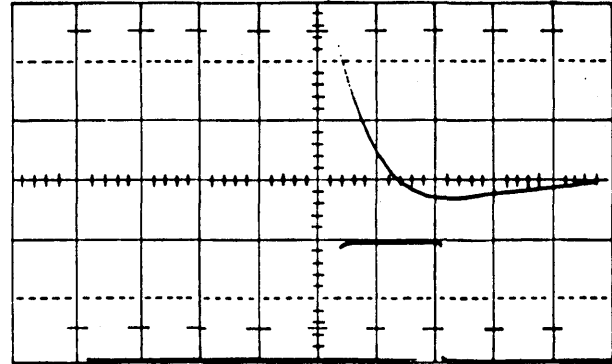

B CORRECT

HOR —1MS/CM
VERT —0.2V/CM

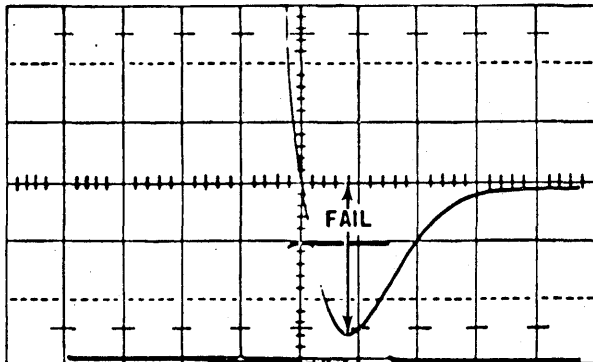

C GAIN TOO HIGH

HOR —1MS/CM
VERT —0.2V/CM

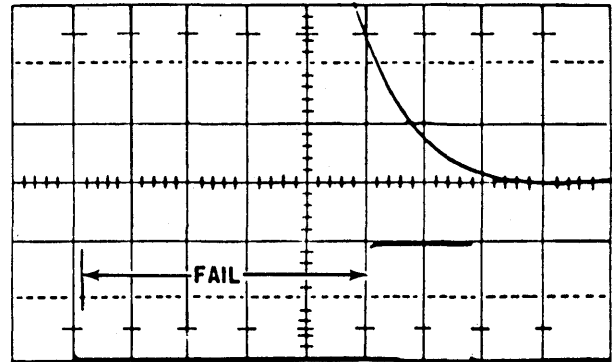

D GAIN TOO LOW

HOR —1MS/CM
VERT —0.2V/CM

7K58

NOTE; ALL UPPER TRACES TPG A21
ALL LOWER TRACES TPJ A28

Figure 6-23. Fine Position Gain Adjustment

NOTE

Adjustment of the potentiometer shaft will, to some extent, affect the trace for each seek operation. Each adjustment of the shaft must be followed by a repeat of the 405 cylinder scan to ensure that some other area is not now failing to meet requirements.

- b. Allow seeks to occur until requirements are not met, then adjust 20K potentiometer (Fine Position Gain Adjust) shaft on card at location A20 until requirement is met.
 - c. Repeat step 12a.
 - d. If requirements are met, disconnect oscilloscope; adjustment is complete.
 - e. If requirements are not met, repeat steps 12a through 12c.
13. Replace logic chassis covers, close rear door and front cover.

INTEGRATOR GAIN CHECK/ADJUSTMENT

1. Open cabinet front cover.
2. Install a disk pack and close front cover.
3. Start unit and allow heads to load.
4. Connect oscilloscope external trigger to wire wrap pin 15A (T₃₂) at location A12. Set trigger to positive.
5. Connect oscilloscope ground lead to GND test point A or Z of a logic card.
6. Connect oscilloscope probe to test point E (Desired Velocity Function Generator) at location A17.

NOTE

It is necessary to command seek operations in the following procedure. These commands may be derived by a field test unit or the applicable in-line diagnostic (refer to controller CE manual for procedure).

7. Command unit to perform a 64 cylinder continuous seek between cylinders 0 and 64.
8. Adjust oscilloscope horizontal sensitivity to obtain one negative and one positive sloped trace (approximately 2 ms/cm). Set vertical sensitivity to 2 v/cm.

NOTE

Velocity integrator functions to fill in (smooth out) the stepped output of the D/A converter. Integrator gain must be adjusted so that function generator output is smoothed out and does not contain points of discontinuity along its slope. Figure 6-24, part C, shows a faulty adjustment.

9. Compare the trace to Figure 6-24, part A. Trace slopes must be smooth and contain no discontinuities.
10. If requirement is met, disconnect oscilloscope; check is complete. If requirement is not met, adjust as follows:
 - a. Set oscilloscope horizontal sensitivity to 1 ms/cm.
 - b. Adjust 10K potentiometer shaft (Velocity Integrator Adjust) on outer edge of card at location A17 (top pot on card) until trace slope is smooth and contains no points of discontinuity.
 - c. Disconnect scope; adjustment is complete.

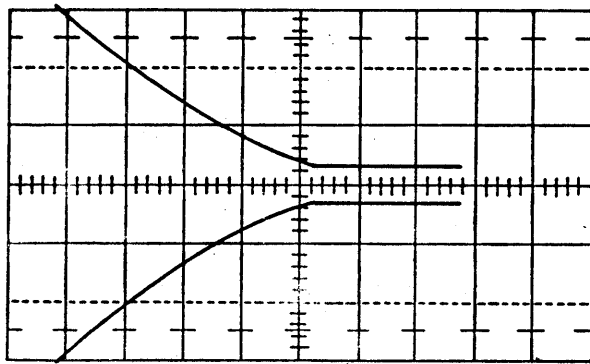

A CORRECT

HOR - 2MS/CM
VERT - 2V/CM

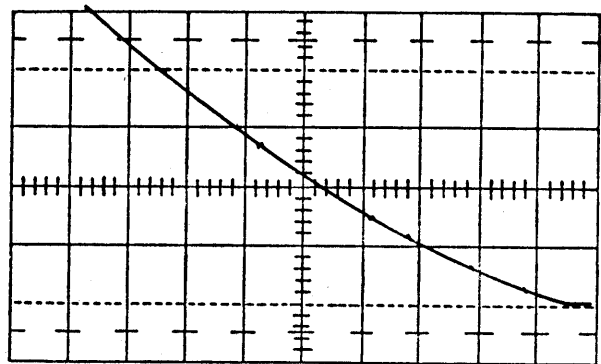

B CORRECT

HOR - 1MS/CM
VERT - 1V/CM

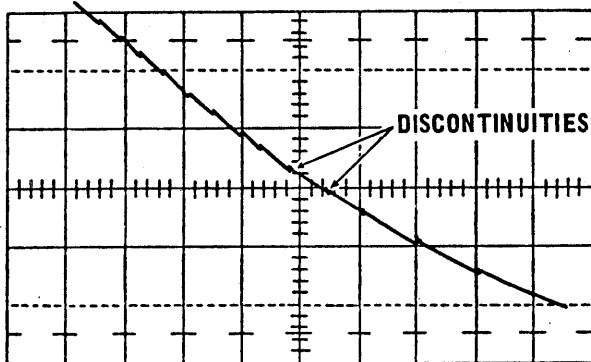

C FAULTY

HOR - 1MS/CM
VERT - 1V/CM

**NOTE: TRACE SHOWS FUNCTION
GENERATOR OUTPUT (TPB, A27)
FOR FORWARD AND REVERSE SEEK**

6T57

Figure 6-24. Integrator Gain Adjustment



SECTION 7

MAINTENANCE AIDS

Information for this section is included in BR5A5
Disk Storage Unit, Publication Number 83302400.

SECTION 8

PARTS DATA

Information for this section is included in BR5A5
Disk Storage Unit, Publication Number 83302500.

SECTION 9

WIRE LISTS

Information for this section is included in BR5A5
Disk Storage Unit, Publication Number 83302400.

SECTION 10

EQUATION SUMMARY

(Not Applicable)

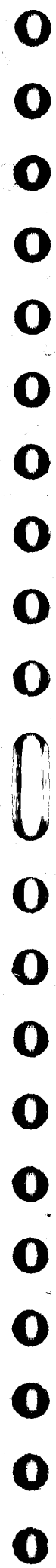

COMMENT SHEET

PLEASE COMPLETE ITEMS 1 THRU 11

From

(1) NAME
(2) DEPARTMENT OR ATTENTION OF
(3) STREET ADDRESS
(4) CITY AND STATE

Manual Information

(From Revision Record)

(5) MANUAL TITLE	
(6) PUBLICATION NO.	(7) REVISION
(8) FCO'S INCORPORATED INTO MANUAL	

Equipment Information

(From Equipment Nameplate & FCO Log)

(9) EQUIPMENT NO. AND DESCRIPTION
(10) SERIES CODE
(11) FCO'S INCORPORATED INTO EQUIPMENT

Comments

This form is not intended to be used as an order blank. Your evaluation of this manual will be welcomed by Control Data Corporation. Any errors, suggested additions or deletions, or general comments may be made above. Please include references to figure number, assembly number and design configuration level.

CUT ALONG LINE

148R 0502 PRINTED IN U.S.A.

NO POSTAGE STAMP NECESSARY IF MAILED IN U. S. A.

FOLD ON DOTTED LINES AND STAPLE

STAPLE

STAPLE

FOLD

FOLD

FIRST CLASS
PERMIT NO. 8241
MINNEAPOLIS, MINN.

BUSINESS REPLY MAIL
NO POSTAGE STAMP NECESSARY IF MAILED IN U.S.A.

POSTAGE WILL BE PAID BY
CONTROL DATA CORPORATION
Technical Publications Department
7801 Computer Avenue
Minneapolis MN 55435

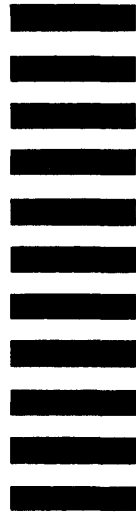

CUT ALONG LINE

FOLD

FOLD