

PART 2



**ALIOS COMPUTER SYSTEMS
8500 CENTRAL PROCESSING UNIT PCB
HARD DISK CONTROLLER PCB
TAPE CONTROLLER PCB
I/O PORT ASSIGNMENTS
SCHEMATICS**

Table of Contents

PART TWO

8500 CENTRAL PROCESSING UNIT PRINTED CIRCUIT BOARD AND THE EIGHT INCH HARD DISK CONTROLLER BOARD	1-1
THE 8500 CPU PRINTED CIRCUIT BOARD (PCB)	2-1
Memory	2-1
The Hard Disk Controller (HDC)	2-1
Floppy Disk Controller (FDC)	2-1
Magnetic Tape Unit Controller	2-3
I/O Port Assignments For The 8500 PCB	2-3
Z80 Interrupt Daisy Chain	2-10
Altos Interface Connector Wiring	2-11
ALTOS EIGHT INCH HARD DISK CONTROLLER, MTU CONTROLLER, AND THE SHUGART EIGHT INCH SOFT-SECTORED DRIVE	3-1
Eight Inch Hard Disk Controller	3-1
Commands/Command Ports	3-6
Status/Status Port	3-7
Ports 022H And 021H	3-10
Formatting	3-11
Reading Or Writing A Sector	3-13
Reading A Sector	3-13
Writing A Sector	3-14
Controller Responses	3-15
Shugart Eight Inch Soft-Sector Drive	3-15
Magnetic Tape Controller	3-17

SCHEMATICS

8500 CPU PCB SCHEMATICS
EIGHT INCH HARD DISK CONTROLLER SCHEMATICS
XENTEK 6055 POWER SUPPLY SCHEMATICS
REAR PANEL I/O PCB SCHEMATIC
SHUGART SCHEMATICS
DISK CONTROLLER EIGHT INCH SCHEMATICS

LIST OF FIGURES

2-1	8500 CPU PCB MATRIX MAP	2-2
3-1	EIGHT INCH HDC CONTROLLER BOARD MATRIX MAP	3-2
3-2a	50-PIN DAISY CHAIN CONNECTOR FOR THE EIGHT INCH HDC	3-3
3-2b	20-PIN RADIAL CONNECTOR TO DRIVE 1	3-4
3-2c	20-PIN RADIAL CONNECTOR TO DRIVE 2	3-4
3-2d	34-PIN CPU TO CONTROLLER INTERCONNECT CABLE	3-5
3-2e	POWER CONNECTOR P1	3-6
3-3	MTU CONTROLLER BOARD MATRIX MAP	3-18

LIST OF TABLES

2-1	I/O PORT ASSIGNMENTS FOR THE 8500 PCB	2-4
2-2	BIT ASSIGNMENTS, INPUT/OUTPUT SIGNALS FOR I/O PORTS	2-7
2-3	INTERRUPT DAISY CHAIN	2-10
2-4	SERIAL I/O CONNECTOR	2-11
2-5	PARALLEL I/O CONNECTOR	2-12
3-1	ADDRESSES	3-1
3-2	COMMANDS (PORT 023H)	3-7
3-3	STATUS BYTE (PORT 023H)	3-10
3-4	DRIVE/HEAD BYTE (PORT 020H)	3-11
3-5	HEAD SELECT	3-11
3-6	HEADER IMAGE	3-12
3-7	DISK DRIVE SPECIFICATIONS	3-16
3-8	FORMAT FOR SOFT-SECTORED EIGHT INCH HARD DISK	3-17
3-9	MTU CONTROLLER TO DEI DRIVE SIGNAL PIN ASSIGNMENTS	3-19

1. 8500 CENTRAL PROCESSING UNIT PRINTED CIRCUIT BOARD
AND THE EIGHT-INCH HARD DISK CONTROLLER BOARD.

The following two sections are dedicated to a detailed discussion of the 8500 CPU PCB and the eight-inch hard disk controller PCB. Most of the information contained in these sections are for user reference only.

2. THE 8500 CPU PRINTED CIRCUIT BOARD (PCB).

Most of the data contained in this Section is for information purposes only as the operating system handles the operations discussed herein. The 8500 CPU PCB has the capability of supporting up to four floppy disk drives and up to two eight-inch hard disks. Figure 2-1 is a matrix map of the 8500 PCB.

2.1 Memory.

The 8500 PCB Memory bank switching allows selection of the bank the DMA will access independently of the bank selected for access by the CPU. Thus, the CPU may be operating in one memory bank when the DMA interrupts to read from or write to another memory bank. This requires two more bits (UN3 and UN4) at port 25.

The ability to swap the fixed 16K address space from high-order memory to low-order memory has been facilitated by a pair of jumpers (S21 and S22), on the PCB at matrix positions 12A/B. This jumper allows the user to configure the system for OASIS, CP/M or MP/M operating systems. The write protect function operates on the common memory only, independently of whether common memory is pinned to be in high-order or low-order space.

2.2 The Hard Disk Controller (HDC).

The hard disk controller is a separate PCB that attaches, piggyback, onto the right side mother board. This allows different types of disk drives to be used. Currently, the hard disk controller that will mount on the 8500 board is the for the soft-sectored drives such as the SA1000.

2.3 Floppy Disk Controller (FDC).

When double-sided floppy disk drives are installed, they are pinned for accessibility as one logical drive with two heads via the side-select control line.

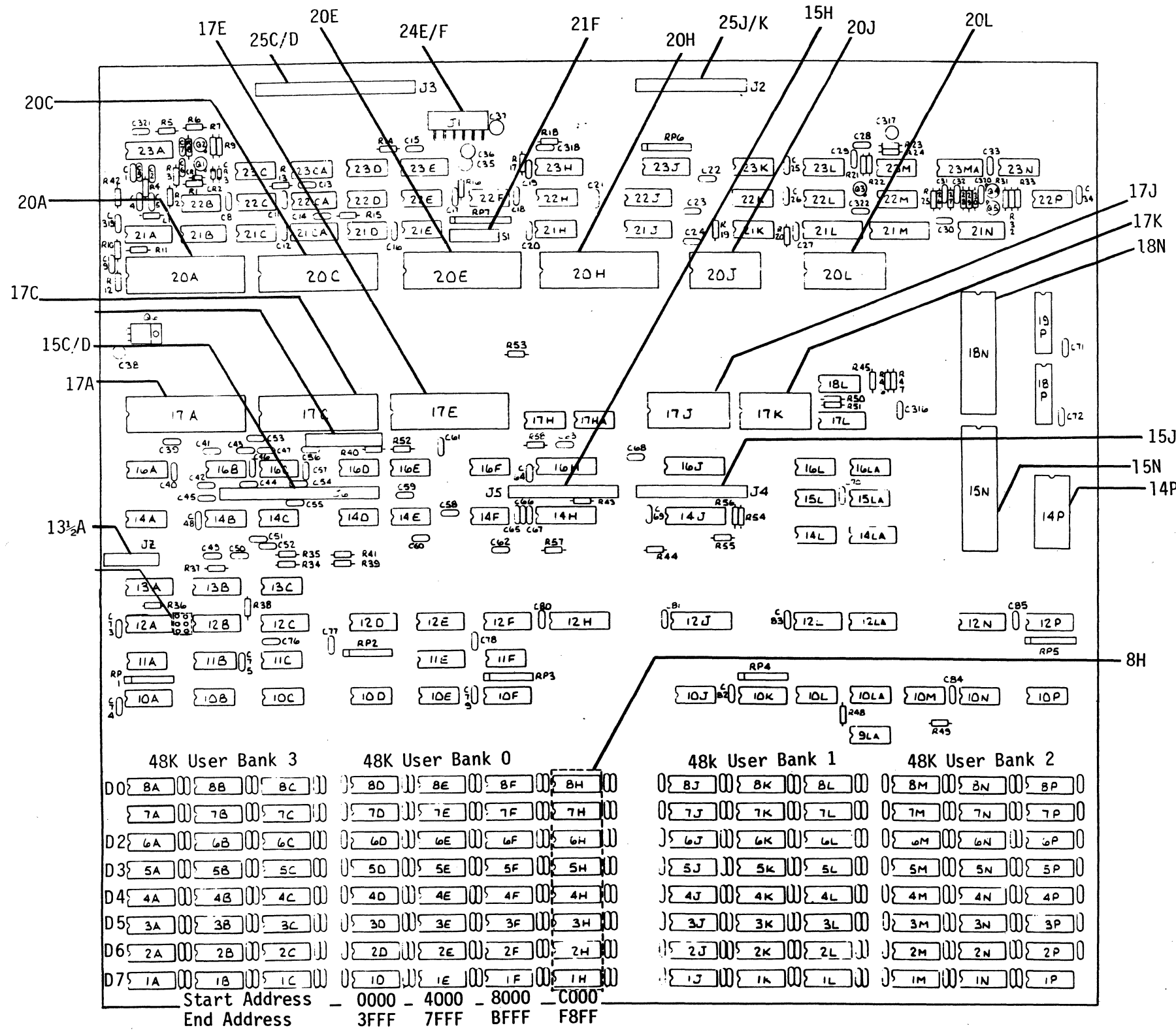

Matrix Position	Purpose
12A/B	Operating System Selection Jumper Block
13 1/2A	High Speed Serial Connector
17A	SIO IC Console #4, Printer #2
15C/D	RS232 Connector to Rear Panel
16 1/2C/D	High Speed Networking Jumper Block
17C	SIO IC Consoles #2 and #3
20A	FDC IC 1797
20C	FDC PIO IC
17E	SIO IC Console #1, Printer #1
25C/D	FDC Connector
20E	PIP IC Memory Bank Select
24E/F	Power Connector
21F	SI System Configuration Block
20H	PIO IC Parallel Printer
25J/K	Parallel Printer Port
15H	MTU Connector
20J	AMD 9511 FPP
20L	CTC IC
17J	Address Decoder IC
17K	CTC IC
18N	Z80
15J	HDC Connector
15N	DMA IC
14P	EPROM IC
8H	16K Ram Common Bank

Figure 2-1. 8500 CPU PCB Matrix Map.

2.3 --Continued.

When switching from one floppy drive to another, it is necessary to force unloading of the head-load signal. This insures that, when the newly selected drive is READ from or WRITTEN to, the head load delay one-shot in the controller circuit will be triggered and delay sufficiently for the head of the newly selected drive to settle. This is done by doing a SEEK with the head load flag bit set to unload the head at the beginning.

The FDC IC chip has been changed from the FD1791 to the FD1797. The 1797 IC chip is able to read to some single-density diskettes that the 1791 cannot.

Bit 1 on the 1797 establishes which side is being compared; bit 3 dynamically alters the code for the sector length field (This is done in conjunction with the sector length byte in the header). Thus, the side select bit changes from bit 3 to bit 1, and the option not to compare is not available. To maintain compatibility with the present sector length field code, bit 3 should be set to bit 1.

The 1797 has an output that can be used to control the side-select line to the disk drive. This happens automatically as determined by bit 1 in the READ and WRITE commands. However, the CPU board is wired to use bit 5 out of the PIO at B7 to do this selection. If necessary, the signal from the 1797 can be used to control side select by cutting a trace and installing a jumper at S25.

2.4 Magnetic Tape Unit Controller.

The magnetic tape controller is a separate PCB that attaches, piggyback, onto the left side of the 8500 board. It currently controls a Data Electronics Inc., (DEI) funnel drive.

2.5 I/O Port Assignments for the 8500 PCB.

Table 2-1 lists the I/O port assignments with their corresponding schematic reference and functions. Table 2-2 lists the bit assignments for the I/O port.

Table 2-1. I/O Port Assignments for the 8500 PCB

PORT NUMBER	SCHEMATIC REFERENCE	FUNCTION
00-03	Y0 (DMA)	Initialize DMA.
04 05 06 07	Y1 (FD1797) (Floppy disk)	Input drive/controller status. Output command. Input/output track number. Input/output sector number. Input data. Output data when WRITING to the disk and the desired track number prior to doing a SEEK.
08 09 0A 0B	Y2 (PIO-CH A) Y2 (PIO-CH B) Y2 (PIO-CH A) Y2 (PIO-CH B)	Input interrupts from FDC and from HDC. Output floppy disk drive select, and recording density. Input END from 9511A, DISK CHANGE, CPU board type and two-sided (TS) signal from floppy disk drive. Out put MR to FDC chip. Initialize channel A. Initialize channel B.
0C 0D 0E 0F	Y3 (CTC-CH 0) Y3 (CTC-CH 1) Y3 (CTC-CH 2) Y3 (CTC-CH 3)	Baud rate generator for console number 1 at JX. not used. Baud rate generator for printer number 1 at JT. Used to count index pulses of the floppy disk drive.
10 11 12 13	Y4 (PIO-CH A) Y4 (PIO-CH B) Y4 (PIO-CH A) Y4 (PIO-CH B)	Parallel port I/O at J2 (normally used in I/O mode). Parallel port I/O at J2 (normally used for data in an I/O mode). Initialize channel A. Initialize channel B.
14-17	Y5 (IPL)	An output to any of these ports turns off the PROM after initial program load (IPL).
18 19 1A 1B	Y6 (9511) " " "	Input/output data from the 9511's stack. Input status, output commands to/from the 9511. Same as 18. Same as 19.

Table 2-1. Continued

PORT NUMBER	SCHEMATIC REFERENCE	FUNCTION
1C	Y7 (DART-CH A)	Input/output data to I/O port at JX (normally Console #1). Input status of channel A. Output commands to CH A.
1E	Y7 (DART-CH B)	Input/output data to I/O port at JT (normally printer number 1).
1F	"	Input status of channel B. Output commands to CH B.
20	Y8 (Hard Disk)	Output drive and head number to HDC.
21	"	Output sector number and old cylinder number to the HDC; also input and output data to or from the hard disk via the DMA.
22	"	Output new cylinder number to the controller.
23	"	Output commands to the controller. Input status of the controller.
24	Y9 (PIO-CH A)	Input configuration of CPU and controllers.
25	Y9 (PIO-CH B)	Input nothing. Output memory write protect bit and memory bank select bits.
26	Y9 (PIO-CH A)	Initialize channel A.
27	Y9 (PIO-CH B)	Initialize channel B.
28	Y10 (SIO-CH A)	Input/output data to I/O port at JV (normally printer number 2 but on the 8500 is reconfigurable as a bisync modem port).
29	"	Input status of channel A. Output commands to CH A.
2A	Y10 (SIO-CH B)	Input/output data to I/O port at JZ (normally console number 4).
2B	"	Input status of channel B. Output commands to CH B.
2C	Y11 (SIO-CH A)	Input/output data to I/O port at JY (normally console number 2). Input/Output data to network port JW
2D	"	Input status of channel A. Output commands to CH A.

Table 2-1. Continued.

2E	Y11 (SIO-CH B)	Input/output data to I/O port at JU (normally console number 3).
2F	"	Input status of channel B. Output commands to CH B.
30	Y12 (CTC-CH 0)	Baud rate clock for console # 2 at JY.
31	Y12 (CTC-CH 1)	Baud rate clock for consoles # 3 and #4 at JU and JZ.
32	Y12 (CTC-CH 2)	Baud rate clock for printer number 2 at JV.
33	Y12 (CTC-CH 3)	Real time clock generator for time slicing the usage of the processor.

Kill Clock
on MP/MI
+ 10
output 21
to 334

Table 2-2. Bit Assignments, Input/Output Signals for I/O Ports

PORT # SCH. REF.	BIT #	DESCRIPTION
<p>00-03 (DMA)</p> <p>04-07 (FD1797)</p> <p>08 Y2 (PIO-CH A)</p>	<p>7</p> <p>6</p> <p>5</p> <p>4</p> <p>3</p> <p>2</p> <p>1</p> <p>0</p>	<p>(See Zilog DMA Manual)</p> <p>(See the applicable Western Digital data sheet).</p> <p>INTERRUPT input from the HDC.</p> <p>INTERRUPT input from the FDC chip.</p> <p>DRIVE SELECT 4 to select drive D. 0=unselected, 1=selected. Select only one drive at a time.</p> <p>DRIVE SELECT 3 to select drive C.</p> <p>DRIVE SELECT 2 to select drive B.</p> <p>DRIVE SELECT 1 to select drive A.</p> <p>HLD input from the floppy disk controller chip to indicate when the head is loaded. 0=not loaded; 1=loaded.</p> <p>DDEN output to set the recording mode. 0=single density, 1=double density.</p>
<p>09 Y2 (PIO-CH B)</p>	<p>7</p> <p>6</p> <p>5</p> <p>4</p> <p>3</p> <p>2</p> <p>1</p> <p>0</p>	<p>TWO-SIDED (TS) input from the floppy disk drive. 0=single-sided diskette, 1=two-sided diskette.</p> <p>Input (hardwired) to indicate the type of PCB. 0=8500..</p> <p>Side select output to the floppy disk drives (unless SSO on the controller chip is used). 0=side 0 selected, 1=side 1 selected.</p> <p>Not connected.</p> <p>Not connected.</p> <p>DISK CHANGE input from the floppy disk drive. (See the disk drive spec sheet for details).</p> <p>(master reset) (/MR) output to the floppy disk controller chip. Normally a 1, take 50 seconds to reset.</p> <p>END, input from the 9511A to indicate the completion of a calculation.</p>
<p>OA</p>		<p>(See Zilog PIO Manual)</p>
<p>OB</p>		<p>(See Zilog PIO Manual)</p>

Table 2-2. Continued.

0C Y3 (CTC-CH 0)	In Out	2 Mhz. Baud rate for channel A of the DART that outputs to JX (normally console number 1).
0D Y3 (CTC-CH 1)	In Out	2 Mhz. Not attached.
0E Y3 (CTC-CH 2)	In Out	2Mhz. Baud rate for channel B of the DART that outputs to JT (normally printer number 1).
0F Y3 (CTC-CH 3)	In Out	Index pulses from the selected floppy disk drives. (None).
10 Y4 (PIO-CH A)	7 6 5 4 3 2 1 0	(Unnamed) normally an input from printer to PIO SELECT " BUSY " PAPER EMPTY " FAULT " CNTL normally an output to the printer. INPUT PRIME " DATA STROBE "
11 Y4 (PIO-CH B)	7 6 5 4 3 2 1 0	DATA 7 normally an output to the printer. DATA 6 " DATA 5 " DATA 4 " DATA 3 " DATA 2 " DATA 1 " DATA 0 "
12-13 Y4 (PIO-CH A)		(See Zilog PIO Manua).
14-17 Y5 (IPL)		An output to any of these ports turns off the PROM after initial program load (IPL)
18,19 Y6 (9511A)		(See the AMD9511A specification sheet).
1A Y6 (9511A)		Same as 18
1B Y6 (9511A)		Same as 19

Table 2-2. Continued.

1C Y7 (DART-CH A)		(Refer to the Zilog Manual)
1D Y7 (DART CH A)		(Refer to the Zilog Manual)
1E Y7 (DART-CH B)		(Refer To Zilog Manual)
1F YA (DART-CH B)		(Refer to Zilog Manual)
20-23 Y8 (Hard disk)		(See the HARD DISK interface specifi-
24 Y9 (PIO-CH A)		All bits have yet to be assigned. They will be pinned to indicate the type(s) of controllers attached to the CPU board.
25 Y9 (PIO-CH B)	7	UN4, MSB of a two bit nibble that sets the bank of memory that DMA accesses.
	6	UN3, LSB of the above nibble.
	5	WRITE PROTECT, output to the hardware to prevent writing into the upper 16K of memory space. 0=not protected, 1=write protected.
	4	UN2, MSB of a two bit nibble that sets the bank of memory that the CPU accesses.
	3	UN1, LSB of the above nibble.
	2	Unassigned.
	1	Unassigned.
	0	Unassigned.
26, 27		(Refer to the Zilog Manual)
28 (SIO-CH A) 28 to 2B		Console # 4
2A Y10 (SIO-CH B)		Printer #2
2B		(Refer to the Zilog Manual)
2C (SIO-CH A) 2C to 2F		Console # 2
2D		(Refer to the Zilog Manual)
2E Y11 (SIO-CH B)		Network 1

Table 2-2. Continued.

30 Y12 (CTC-CH 0)	In Out	2Mhz. Baud rate for channel A of the SIO that outputs to JY (normally console number 2).
31 Y12 (CTC-CH 1)	In Out	2Mhz. Baud rate for channel B of the SIO that outputs to JU and channel B of the SIO that outputs to JZ (normally consoles 3 and 4).
32 Y12 (CTC-CH 2)	In Out	2Mhz. Baud rate for channel A of the SIO that outputs to JV (normally printer number 2).
33 Y12 (CTC-CH 3)	In Out	2Mhz. (none).

2.6 Z80 Interrupt Daisy Chain.

On the Z80 interrupt chain the SIOs are at the bottom of the chain so they can return from interrupt by a command rather than by RETI instruction which ripples down the daisy chain. See Table 2-3 for the interrupt daisy chain sequence.

Table 2-3. Interrupt Daisy Chain

Top of chain	Y0	DMA
	Y2	PIO (Hard disk, Floppy disk and 9511 interrupts)
	Y4	PIO (user's port)
	Y3	CTC (Baud rates and timer)
	Y12	CTC (baud rates and real time clock)
	Y7	SIO (console 1 and Printer 1)
	Y10	SIO (printer 2 and Console 4)
Bottom of Chain	Y11	SIO (Consoles 2 and 3)

2.7 ALTOS Interface Connector Wiring.

Table 2-4 lists the pin connections of the device connectors on the rear of the ACS8000 computer. All of the console connectors are Serial I/O devices as is the serial printer jack. The auxiliary printer connector is a Parallel I/O device available to the user.

Table 2-5 lists the Parallel I/O Pin connectors.

Table 2-4. Serial I/O Connector

Pin	Use
1	Chassis Ground
2	Transmitted Data
3	Received Data
4	Request to Send
5	Clear to Send
6	Data Set Ready
7	Signal Ground
20	Data Terminal Ready*

*All ALTOS CP/M, MP/M and ADX system diskettes require pin 20 (Data Terminal Ready) handshaking.

Other pins are not used. Request to Send (pin 4) and Clear to Send (pin 5) are not normally implemented. Jumpers on the Printed Circuit board allow their connection. Pin 8 is tied high through a resistor. Contact ALTOS for instructions for activating Request to Send or Clear to Send.

Table 2-5. Parallel I/O Connector

Pin	Use
1	Data Source
2	Data 0
3	Data 3
4	Data 1
5	Data 6
6	Data 7
7	Acknowledge
8	Busy
9	Data 2
10	Data 4
11	Data 5
12	Control
13	Select
14	+5 Volts
15	Paper Empty
16	-12 Volts
17	Input Prime
18	Floating
19	Floating
26	Unassigned
34	Fault
35	Unassigned
36	+12 Volts

All of the remaining pins are ground

3. ALTOS EIGHT INCH HARD DISK CONTROLLER, MTU CONTROLLER,
AND THE SHUGART EIGHT-INCH SOFT-SECTORED DRIVE.

Most of the data contained in this Section is for information purposes only, as the operating system handles the operations discussed herein. This section discusses the ALTOS eight-inch hard disk controller, the MTU controller, and the specifications for the Shugart eight-inch soft sectored drive. For further information on the Shugart eight-inch soft-sectored drive, refer to the SA1000 Fixed Disk Drive Service Manual.

3.1 Eight-inch Hard Disk Controller.

See Figure 3-1 for a diagram of the eight-inch hard disk controller matrix map. Jumper S1 on the controller must be set to coincide with the type of hard disk in the system. This must be set to S for the Shugart drive. This jumper determines the cylinder number, 128, at which write precompensation takes place. See Figures 3-2a, b, c, d and e for connector and pin assignments for the eight-inch hard disk controller.

Data is stored on the disks in blocks or sectors of 256 bytes (not programmable), identified by cylinder, head and sector numbers. The addresss for each sector is previously written (by a FORMAT command) ahead of the data field. When reading from or writing to the disk, this address is read and verified. A correct match must be found for the address and its check bytes before the sector can be written to or read from.

The general procedure to read or write data is to first position the heads over the desired cylinder via a SEEK command, load the head and sector numbers into the appropriate ports, and finally, issue a READ or WRITE command. When the correct sector is found, the data is transferred between disk and system memory under control of the DMA by way of a FIFO buffer. The controller is addressed by way of four I/O ports (020H-023H). Table 3-1 lists the four ports and their corresponding read and write addresses.

Table 3-1. Addresses

Port	Read	Write
020H	X	Drive and head numbers
021H	Data	Old cylinder number (in two bytes), sector number and data
022H	X	New cylinder number in two bytes
023H	Status	Commands

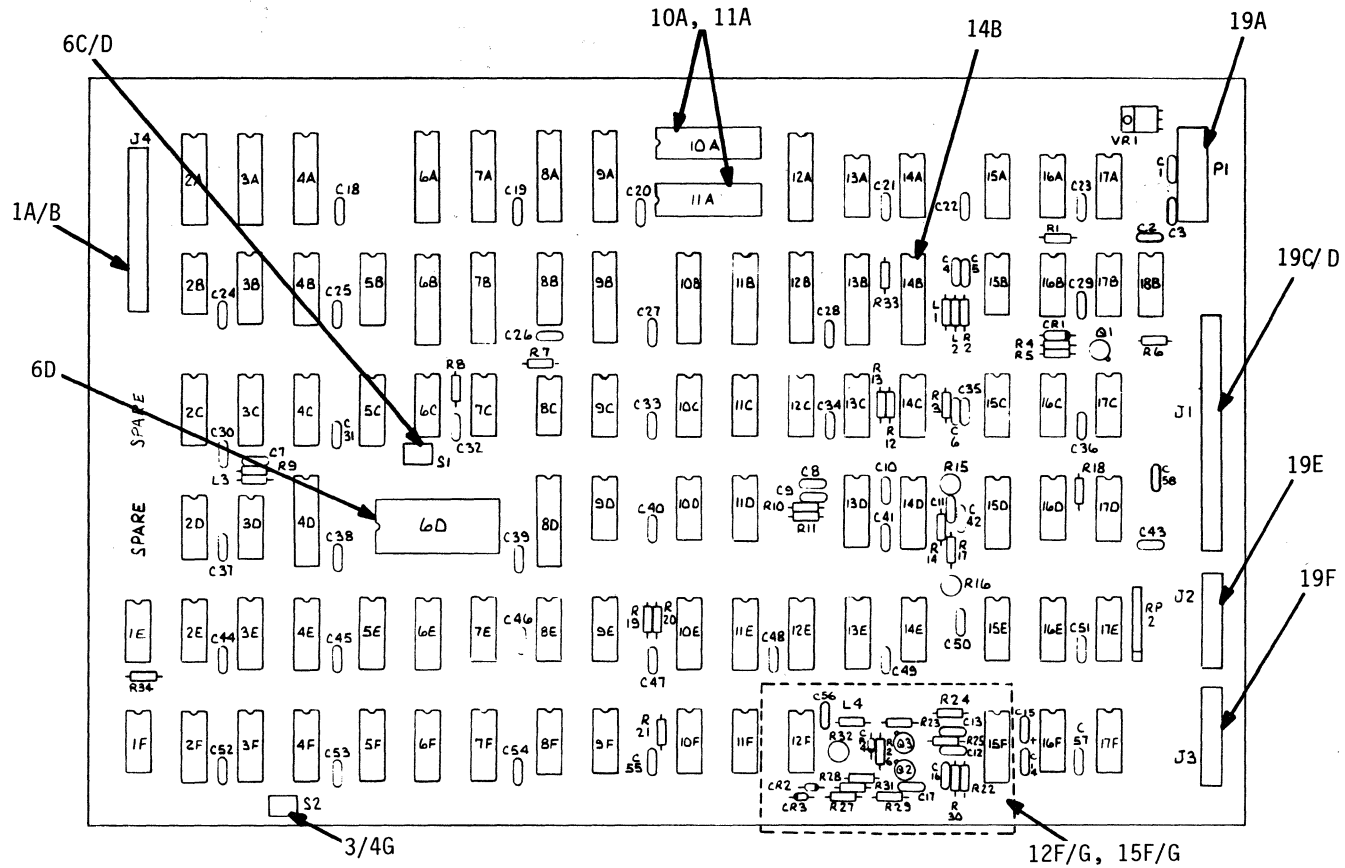

- | | | | |
|------|--------------------------------|-------|------------------------------------|
| 6C | FPLA | 19A | P1 Power |
| 1A/B | J4 CPU Interface | 19C/D | J1 50-Pin Daisy Chain Cable |
| 6C/D | S1 Precomp Block | 19E | J2 20-Pin Radial Cable Drive 1 |
| 10A | } FIFO Buffers | 19F | J3 20-Pin Radial Cable Drive 2 |
| 11A | | 12F/G | } PLO Circuitry |
| 14B | Programmable Array Logic (PAL) | 15F/G | |
| | | 3/4G | S2 Sector Size Configuration Block |

Figure 3-1. Eight-Inch HDC Controller Board Matrix Map.

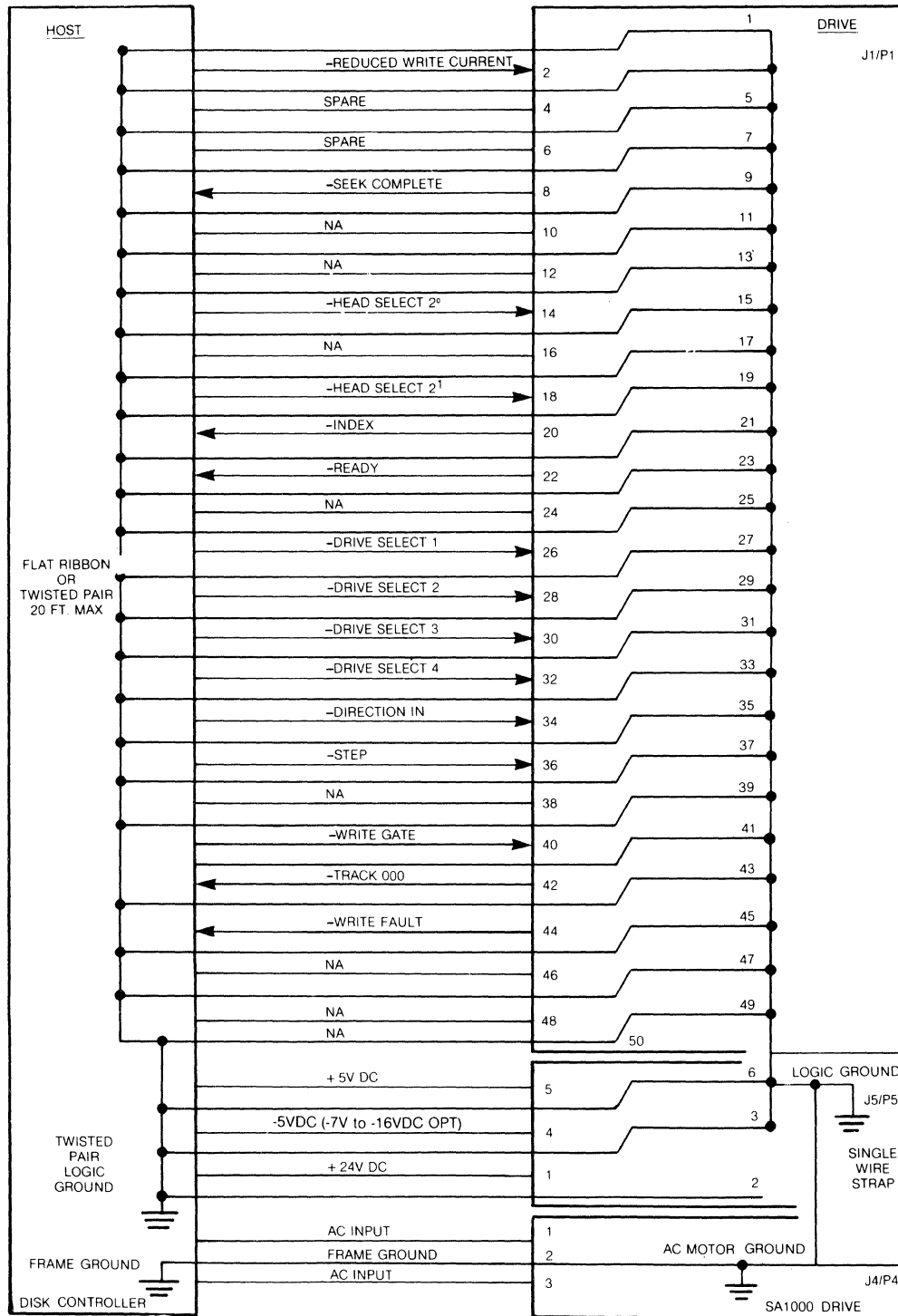

Figure 3-2a. 50-Pin Daisy Chain Connector for the 8-inch Hard Disk Controller

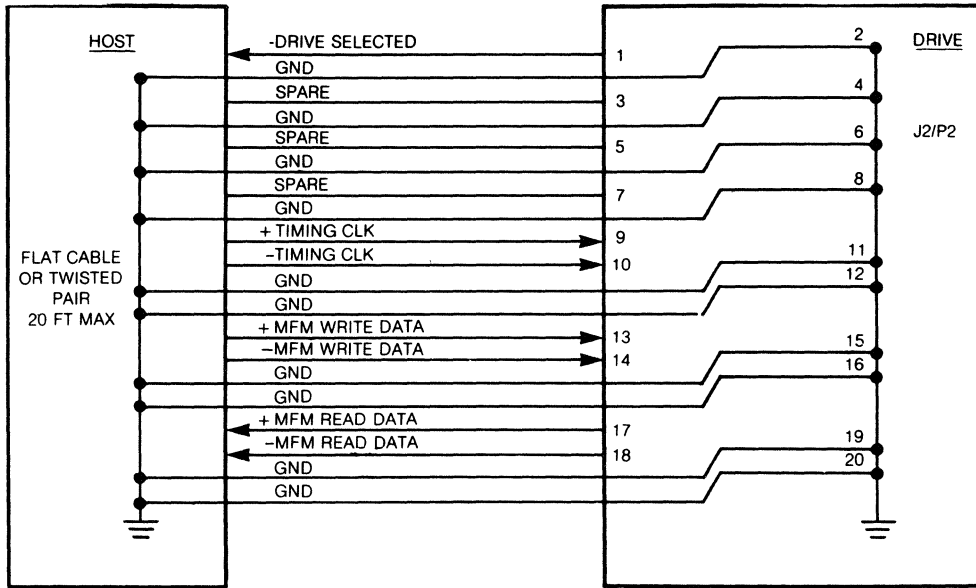

Figure 3-2b. 20-Pin Radial Connector to Drive 1

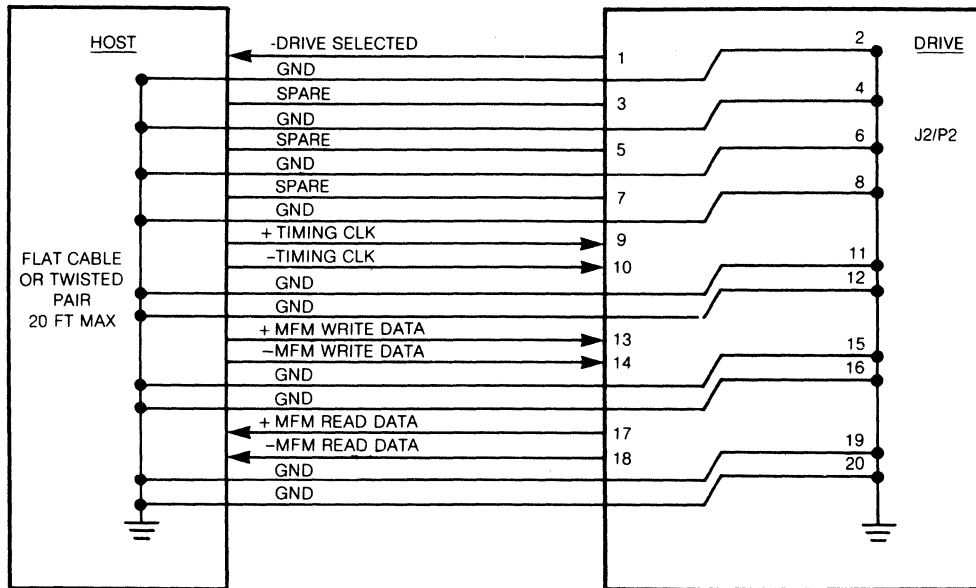

Figure 3-2c. 20-Pin radial connector to Drive 2

- 1 Ground
- 2 INT (interrupt), output to CPU, goes true at completion of a command
- 3 (not used)
- 4 /HDWR, output from controller, negative AND of controllers' address (Y8) and /IOWR, used to control transceivers on the CPU PCB
- 5 /Y15 (not used by this controller)
- 6 Ground
- 7 /HDRD, output from controller, negative AND of controllers' address (Y8) and /IORD, used to control transceivers on the CPU PCB
- 8 /MR RESET from CPU
- 9 Ground
- 10 /IORD, input to controller, negative AND of /RD and /IORQ
- 11 DIOB3
- 12 DIOB7 (MSB of bidirectional data bus)
- 13 DIOB2
- 14 Ground
- 15 DIOB1
- 16 DIOB6
- 17 Ground
- 18 /IOWR, input to controller, negative AND of /WR and /IORQ
- 19 /HDWAIT, output (not used by this controller)
- 20 DIOB5
- 21 DIOB4
- 22 Ground
- 23 DIOB0, (LSB of bidirectional data bus)
- 24 AB0, input, (LSB of CPU's address bus)
- 25 Ground
- 26 AB1, input
- 27 /RDMA, (ready DMA), output from controller to start and pace transfer of data
- 28 /BUSAKB, (bus acknowledge output bit), input from CPU, true-to-false transition is used by controller to recognize completion of a data transfer
- 29 System clock
- 30 Ground
- 31 /Y8, input to controller, used with AB0 and AB1 to address the controller
- 32 /RDB (CPU/DMA read signal), output from controller to properly position the RDMA signal (i.e., early in a transfer cycle)
- 33 Ground
- 34 1Mhz input from CPU

Figure 3-2d. 34-Pin CPU-to-Controller Interconnect Cable

1	Ø	Volts
2	Ø	Volts
3	-12	Volts
4	+5	Volts
5	+5	Volts
6	+12	Volts (not used by this controller)

Figure 3-2e. Power Connector P1

3.1.1 Commands/Command Ports.

Port 023H is the command port when writing and the status port when reading. There are seven commands that may properly be issued. These commands, when issued, cause associated circuitry functions. Table 3-2 contains the Commands and associated bit number.

COMMAND	FUNCTION
NULL	Quiescent state
RESET	Initializes the controller circuit. A reset is done automatically at power on and is not normally required thereafter.
RECAL	Positions the heads over track zero. This must be done for each drive following power on before any disk access is attempted and thereafter as part of the error recovery routine. A recal requires about 18 msec/cylinder for a maximum time of approximately 4 seconds.
SEEK	Moves the heads from the programmed "old cylinder" to the programmed "new cylinder".
READ	Reads the addressed sector from the disk.
WRITE	Writes to the addressed sector to the disk.

3.1.1 --Continued.

FORMAT Formats an entire track. (This consists of writing out the address or header for each sector on the specified track by cylinder and head.)

Table 3-2. Commands (Port 023H)

Command	bit number								Hex
	7	6	5	4	3	2	1	0	
NULL	0	0	0	0	0	0	0	0	00
READ	0	0	0	0	X	0	0	1	01
WRITE	0	0	0	0	X	0	1	0	02
FORMAT	0	0	0	0	X	1	0	0	04
SEEK	0	0	0	1	X	0	0	0	10
RECAL	0	0	1	0	X	0	0	0	20
RESET	1	0	0	0	X	0	0	0	80

3.1.1 --Continued.

No more than one command may be issued at one time. For all the commands except NULL and RESET, when the command has been completed, the controller will issue an interrupt (via the PIO at port 008H bit 7). Following the interrupt, the status port is read to clear the status register via the clearing all status latches and to permit subsequent interrupts. If more than one command is outstanding (i.e., a second command issued before the status register is cleared), both commands will be aborted.

3.1.2 Status/Status Port.

The status byte, also on port 023H, reports on the status of the drive or controller. The status byte should be read at the completion of every operation. Table 3-3 lists the bits of the Status Byte and their meaning.

STATUS BYTE

DESCRIPTION

READY

Indicates that the selected drive has power and is up to speed. No operation will take place until a drive is selected and ready is true. Normally being READY indicates that the drive is ready to be read from or written to but a special case exists with this Shugart drive: upon being powered on these drives require a two minute stabilization time before they should be read from or written to. Unfortunately, READY will go true before these two minutes are up (in about five seconds) and does not allow for this warm-up time.

WRITE FAULT

Indicates a disk error during writing. To clear a write fault, the selected drive must be de-selected then re-selected.

CRC ERROR

Indicates that either the header or data field read off the disk was in error. If the operation was a write, the error occurred while reading the header and the sector was not written to. If the operation was a read, then the error could have occurred in either the header or data field. If it occurred in the header, the operation was aborted and the data field was not read. If it occurred in the data field, the data was transferred before the error was detected.

RECORD NOT
FOUND (RNF)

During a READ or WRITE operation the specified header was not found in four revolutions of the disk. This may be caused by a seek error or incorrectly specified head or sector. RNF During a read may also indicate that the data sync field (00, A1 or F8) was not found even after the header was located. This is most likely caused by trying to read a sector that had been formatted, but before it was written to.

3.1.2 --Continued.

BAD SECTOR	The sector to be read or written was previously specified as a bad sector. A sector is flagged as bad during disk initialization with a 1 at bit 3 of the header byte. Good sectors have a 0 at bit 3.
TASK COMPLETE	The requested command was carried out or aborted. Analysis of the status byte will show whether or not the operation was aborted.
BUSY	The controller is in the process of carrying out an operation. BUSY is a 0 at the completion of an operation.

Table 3-3. Status byte (Port 023H)

Bit	Mnemonic	Meaning
7	RDY	Selected drive is ready
6	WR FLT	Write fault (from drive)
5	(none)	
4	CRC ERR	CRC error encountered
3	RNF	Record not found
2	BD SECT	Bad sector encountered
1	TC	Task complete
0	BUSY	Busy

3.1.3 PORTS 022H, 020H and 021H

Port 022H is used for writing the new cylinder number. This is entered in two consecutive bytes, the low order eight bits first, then the high order three bits.

Cylinder Bytes	Bits							
Least significant	7	6	5	4	3	2	1	0
Most significant	X	X	X	X	X	A	9	8

Port 021H has the following three functions:

- a. Before doing a SEEK the old cylinder is entered (in two bytes as for new cylinder).
- b. Before doing a READ or WRITE, the sector number is entered into this port,
- c. When data is being transferred between disk and memory, it is done through port 021H.

Port 020H is used for selecting the drive and head to be used. The heads are selectable in a binary sequence (limited by the number of heads on the drive). One or the other but not both drives can be selected. Table 3-4 contains the drive-head byte bit numbers, names and their functions.

Table 3-4. Drive/head byte (Port 020H)

Bit	Name	Function
7	HS3	Head select bit 3
6	HS2	Head select bit 2
5	HS1*	Head select bit 1
4	HS0*	Head select bit 0
3		(none)
2		(none)
1	DS2	Drive select 2
0	DS1	Drive select 1

*Table 3-5. Head Select

Head Select Bits		Head Number
HS1	HS2	Selected SA1004
0	0	0
0	1	1
1	0	2
1	1	3

3.2 Formatting.

Since the SA1000 drive is soft-sectored, an entire track must be formatted at one time to maintain the proper timing relationship among the sectors. The heads must be positioned to the desired cylinder using the SEEK command. Then a header image consisting of four bytes, an 0FEH, cylinder number, head number, and sector number must be placed in memory and written out to the disk by the DMA. This is done as each sector arrives under its head during one rotation of the disk. The cylinder number in the header must agree with the cylinder on which the heads are positioned. The head number must agree with the selected head. The sector number does not have to correspond to any system, allowing for staggering of the sectors if required. The DMA must be programmed for a four-byte continuous transfer. Table 3-6 lists and describes the byte header image.

Table 3-6. Header Image

Byte	Description
Sync	ØFEH
Cylinder	Low-order bits (7-Ø) of the cylinder number
Head	Head bits (3-Ø) in the top four bits, a bad sector flag at bit 3, and high order cylinder bits (A-8) at the bottom three bits
Sector	Sector number in hex

The FORMAT command must be issued to write a header. When that header has been written, an interrupt is generated. Then the header image must be updated to the next sector number (only the sector numbers change down the track), and a new FORMAT command issued before the next sector arrives at the head (464 μ seconds for a 256-byte sector). The program must also keep count of the number of sectors that have been formatted and stop issuing the FORMAT command when the last command for that track has been written. When the interrupt occurs following the writing of the last sector's header, the status must be read and when the next interrupt occurs, the track is completely formatted and another command may be issued. (Following the next to last interrupt, a dummy or null command may be issued if necessary).

To format the entire disk the above procedure must be repeated for each head of each cylinder.

256 and 512 byte sector sizes are provided for. One track will accommodate 31 sectors at 256 bytes or 17 sectors at 512 bytes. Sector size is determined by jumper S2 on the controller. Two jumpers are used. Both must be in either the 256 or the 512 byte position.

The controller fills in every byte of the data field with Ø4EH while formatting. Following the formatting of a track, any attempt to read a sector on that track that has not been specifically written to will result in a RECORD NOT FOUND (RNF) since the sync bytes will be missing for these sectors. Each sector must subsequently be written to with some other data, (e.g., ØE5H to initialize the sector for CP/M or MP/M. Any data stored on a track is destroyed when that track is formatted.

3.2 --Continued.

The sequence of sectors on a track is under control of the formatting program. Physically adjacent sectors should not be read or written sequentially, because the data is transferred between disk and main memory under DMA control. System memory, composed of dynamic RAM, requires periodic clocking to maintain its data. This refresh is normally done by the CPU, but when the DMA is active, the CPU's refresh cycles are held off. To allow the memory to be properly refreshed, the CPU must regain control and generate the refresh cycles.

Soft sectoring the drive prevents performance of a specific READ ID command since the location of the sector on a track is unknown. When READING or WRITING, a sector is located by reading all the headers encountered along the track until the correct header is found. In a READ command, when the correct header is found, the header bytes are read off the disk and transferred into memory. As a diagnostic this verifies that the data read was from the specified sector.

3.3 Reading or Writing a Sector.

Assuming the drive has been properly initialized following power on by selecting and RECALing the drive, SEEK the desired cylinder loading the old cylinder number at port 021H (following a RECAL this would be 000H), loading the new cylinder number at port 022H, then issuing a SEEK command. An interrupt will occur when the head has arrived at the new cylinder and settled down (no additional head settle time is required).

To write or read a sector the sector must first be found. The controller does this by comparing the header images (written on the disk during formatting) as they pass under the head, to the bytes programmed into ports 020H-022H (020H has the head number, 021H has the sector number and 022H has the new cylinder number). The sector register gets written-over by data during a write. Before the next read or write command the sector number must be reissued to port 021H. Also, in switching between drives, even if a seek is not necessary, port 022H must be reloaded with the new cylinder number.

3.3.1 Reading a Sector.

To read a sector follow the procedure below:

- a. Prepare a buffer area in main memory, to which the data from disk can be placed.

3.3.1 --Continued.

- b. Program the DMA to transfer the desired number of bytes, either 256 or 512 for WRITE, or 259 or 515 for READ, from the controller's I/O port, 021H, to the buffer in memory using the CONTINUOUS mode and standard memory, and I/O timing (to properly pace the FIFO). When doing a READ, three additional bytes of header information that precede the data, cylinder, head/drive and sector are read off the disk. Just as they are written out during formatting. Along with 256 or 512 bytes of data these three bytes must be transferred by the DMA. There are also two bytes of CRC that follow the data. These may be transferred but it is not a requirement. Also, the DMA transfers one more byte than programmed for. Thus, the number of bytes the DMA is programmed to transfer will end up being two or four bytes longer than the sector length.
- c. Load the address, cylinder, head/drive and sector, of the sector to be read. The cylinder number should already be correct from having done a SEEK.
- d. Load the head number to port 020H without changing the drive number (they share the same byte).
- e. Load the sector number at port 021H. A 20- μ second delay is required between selecting a drive or a head and issuing a read or write command, but the inherent programming delays normally take care of this.
- f. Issue the READ command. When the drive/controller locates the desired sector, the controller signals the DMA and the data transfer is carried out by the DMA directly into memory. When the transfer is complete, the controller generates another interrupt and clears out the READ command. The status register must then be read. If a RNF is indicated, the data was not transferred to memory. If a CRC ERR for BAD SECTOR is indicated, the data was transferred but its accuracy is questionable.

3.3.2 Writing a Sector.

To write to a sector follow the procedure given below:

- a. Fill the buffer area with data to be written to the disk. The header and CRC bytes are provided by the hardware, so only the data bytes must be transferred by the DMA.

3.3.2 --Continued.

- b. Read the status register. If a RNF, CRC ERR, or BAD SECTOR is indicated, the data was not written to the disk. When writing, all the sync bytes are provided by the controller (in contrast with the technique used for the SA4000 which required a sync byte ahead of the data). However, when FORMATTING the drive, a sync byte of 0FEH must precede the header bytes.

3.4 Controller Responses.

It a command is issued before a drive is ready or selected, the controller will wait until the selected drive is ready before carrying out the operation. An interrupt is generated when the operation is completed.

Pressing RESET does not generate an interrupt; neither does selecting or deselecting a drive.

Reading from, and writing to the disk cannot be done by the CPU because of the high data rate. Except for some diagnostic tests, the data must be transferred by the DMA.

To prevent extraneous writes to the disk when the power goes off, the controller has a sensing circuit that de-selects the drives when the +5v supply falls below +4.5V. This circuit does not, however, guarantee that data being written to a sector will be retained if power goes off. To insure data retention, power down the system only when no writing is being done to the disk.

3.5 Shugart Eight-inch Soft-sectored drive.

- a. Logical Drives E and F are associated with the first hard disk. Drive E has a formatted capacity of approximately 8 Mbytes. Drive F has a formatted capacity of approximately 500 Kbytes.
- b. Logical Drives G and H are associated with the second hard disk. Drive G has a formatted capacity of Approximately 8 Mbytes. Drive H has a formatted capacity of approximately 500 Kbytes.

Table 3-7. DISK DRIVE SPECIFICATIONS

Nominal track capacity	10416 bytes
Min track capacity (-3% speed)	10102 bytes
Formatted capacity (at 512 bytes)	8,912,896 bytes
Transfer Rate	230 nsec/bit 1.84 μ sec/byte
Access Time	
Track to track	19 ms
Average	70 ms
Maximum	150 ms
Average latency	9.6 ms

Table 3-8. Format for Soft-sectored eight-inch Hard Disk

Start at:	Index Pulse	Character(s) Written	
	16	4E	
	14	00	Repeated 17 times for 512 byte sectors when the cylinder is formatted
	1	A1*	
	1	FE	
	1	[cylinder no.]	
	1	[head no.]	
	1	[sector no.]	
	2	[CRC character]	
	10	00	
	12	00	
	1	A1*	Written out when a sector is written to
	1	F8	
	512	[Data character]	
	2	[CRC character]	
	3	00	
	15	4E	
	(as required)	<or>	
Stop at:	until sub-	4E	
	sequent Index		
	pulse		

* Character written with one missing clock pulse.

3.6 Magnetic Tape Controller.

Figure 3-3 is the MTU Controller Matrix Map. Table 3-9 lists the signal-pin connections for the cable from the MTU Controller to the DEI tape drive.

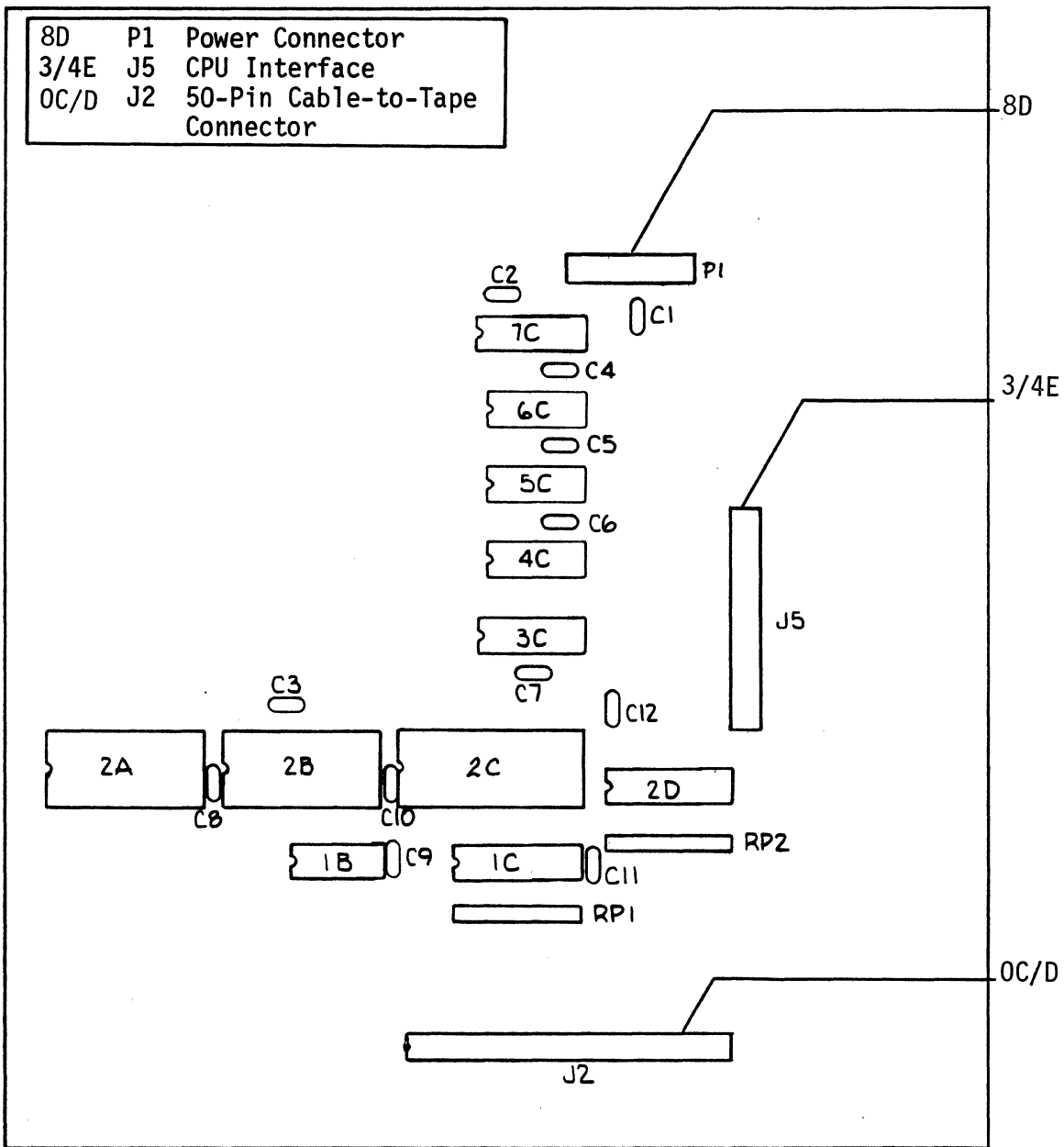

Figure 3-3. MTU Controller Board Matarix Map

Table 3-9. MTU Controller to DEI Drive
Signal Pin Assignments

PIN #	SIGNAL	FROM	COMMENTS
2	SLD-	Drive	Selected
4	RDY-	Drive	Ready
6	WND-	Drive	Write Enabled
8	FLG-	Drive	Flag
10	LPS-	Drive	Load Point Sensed
12	FUP-	Drive	File Unprotected
14	BSY-	Drive	Busy
16	EWS-	Drive	Early Warning Sensed
18	RWD-	Controller	Rewind
20	REV-	Controller	Reverse
22	FWD-	Controller	Forward
24	HSP-	Controller	High Speed
26	WEN-	Controller	Write Enable
28	SL1-	Controller	Unit Select 2 ⁰
30	SL2-	Controller	Unit Select 2 ¹
32	SL4-	Controller	Unit Select 2 ²
34	SLG-	Controller	Select Gate
36	RNZ-	Drive	Read NRZ Data
38	RDS-	Drive	Read Data Strobe
40	DAD-	Drive	Data Detected
42	WDE-	Controller	Write Data Enabled
44	WNZ-	Controller	Write NRZ Data
46	TR2-	Controller	Track Select 2 ¹
48	WDS-	Drive	Write Data Strobe
50	TR1-	Controller	Track Select 2 ⁰

NOTE: 1) All odd numbered pins are returns.

2) Mating connector: 3M Part Number 3425-3000 or equivalent.

8500 CPU PCB SCHEMATICS

REVISIONS			
LTR	DESCRIPTION	DATE	APPROVED
A	PROTOTYPE		
B	REVISED BD.		
C	REVISED BD. 1ST RUN	1/13/81	E.G.
D	REVISED P.D. 2ND RUN	2/10/81	C.N.
E	REVISED P.D. #0007	4/9/81	C.N.
F	REVISED P.D. #0030	5/14/81	E.G.
G	REVISED P.D. #0031	5/11/81	E.G.

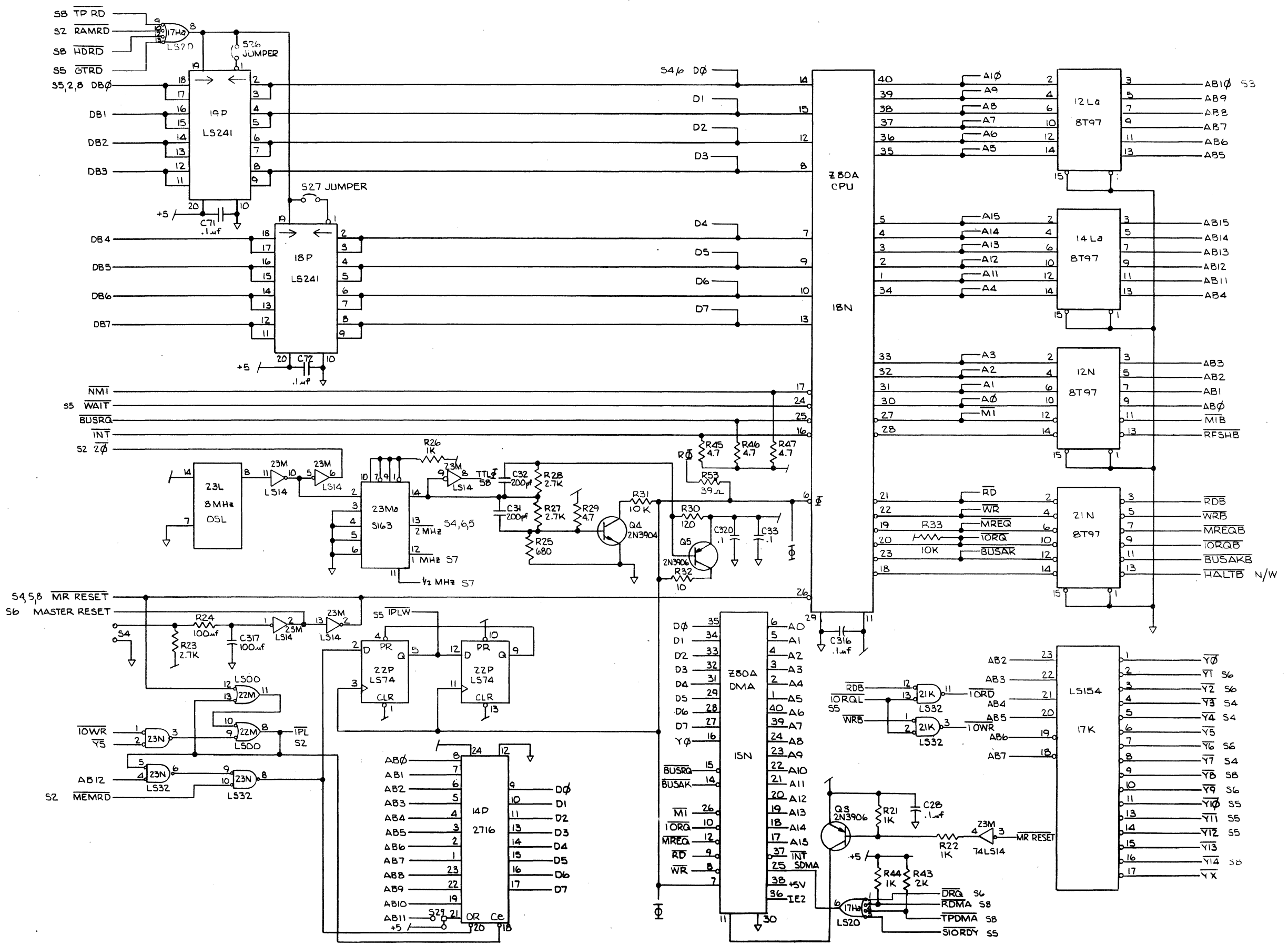

- SPARE GATES
- 23N LS32 2SP
 - 21K LS32 2SP
 - 10N 574 1SP
 - 12B LS75 2SP
 - 12A SI39 1SP
 - 10M LS00 1SP
 - 22L LS32 1SP
 - 22K LS02 1SP
 - 23K LS00 2SP
 - 16L LS04 3SP
 - 15L LS32 1SP
 - 16L LS02 1SP
 - 14L LS08 1SP
 - 13C LS74 1SP
 - 21H LS02 3SP
 - 22C LS32 3SP

NOTE: "S" INDICATES SHEET NUMBER

TOLERANCES UNLESS OTHERWISE SPECIFIED		ALTOS COMPUTER SYSTEMS	
FRACTIONS DEC ANGLES	± ± ±	SCHEMATIC CPU P.C. BD.	
APPROVALS	DATE	SCALE	SIZE DRAWING NO.
C.N.	1/13/81		D 205-11243-001 4
CHECKED			DO NOT SCALE DRAWING SHEET 1 of 6

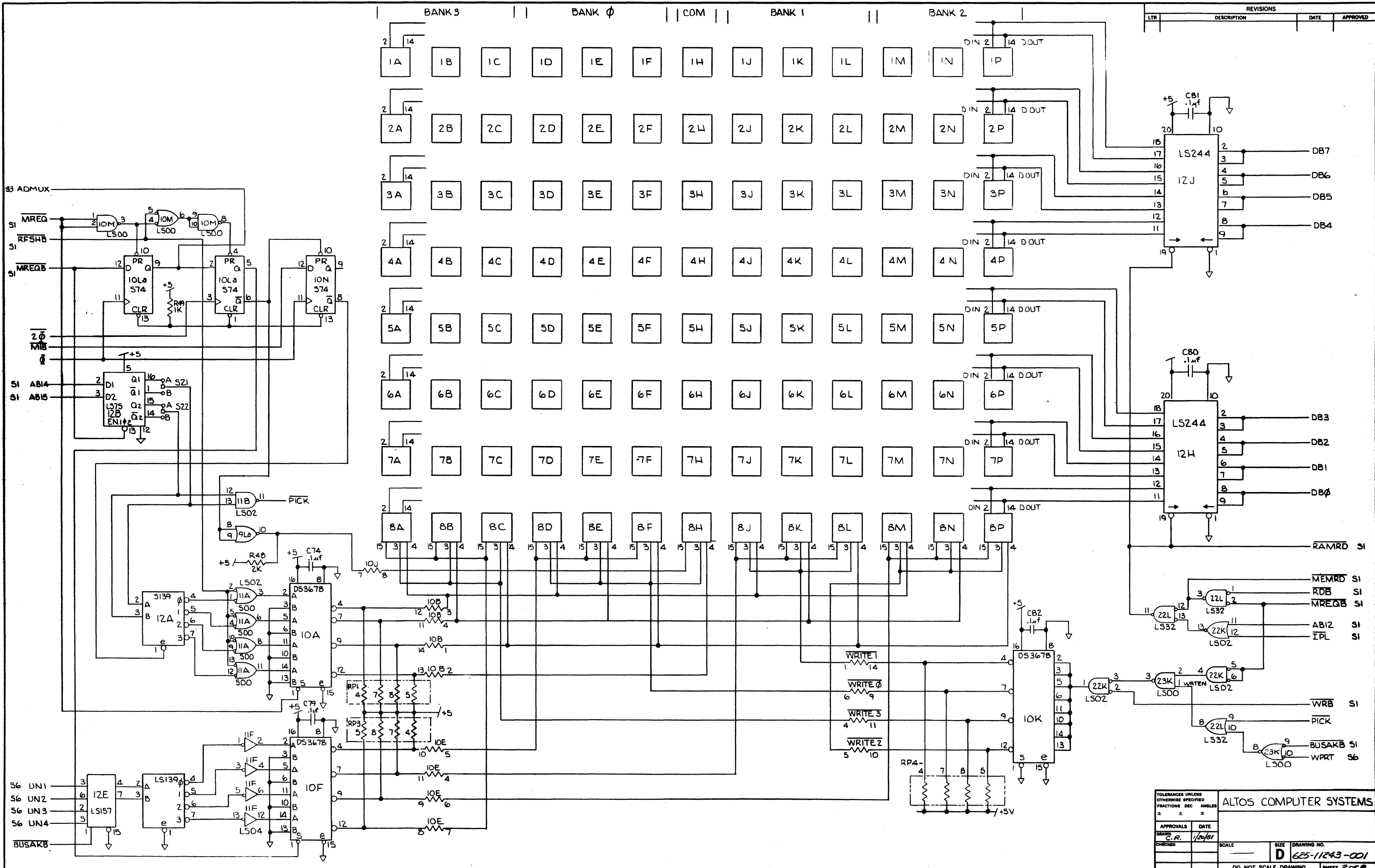

REVISIONS			
LTR	DESCRIPTION	DATE	APPROVED

TOLERANCES UNLESS OTHERWISE SPECIFIED		ALTO COMPUTER SYSTEMS	
APPROVALS	DATE	SCALE	SIZE DRAWING NO.
			D 625-11243-001
DRAWN C.R.	1/20/61		
CHECKED			
DO NOT SCALE DRAWING		SHEET 2 of 3	

REVISIONS			
LTR	DESCRIPTION	DATE	APPROVED

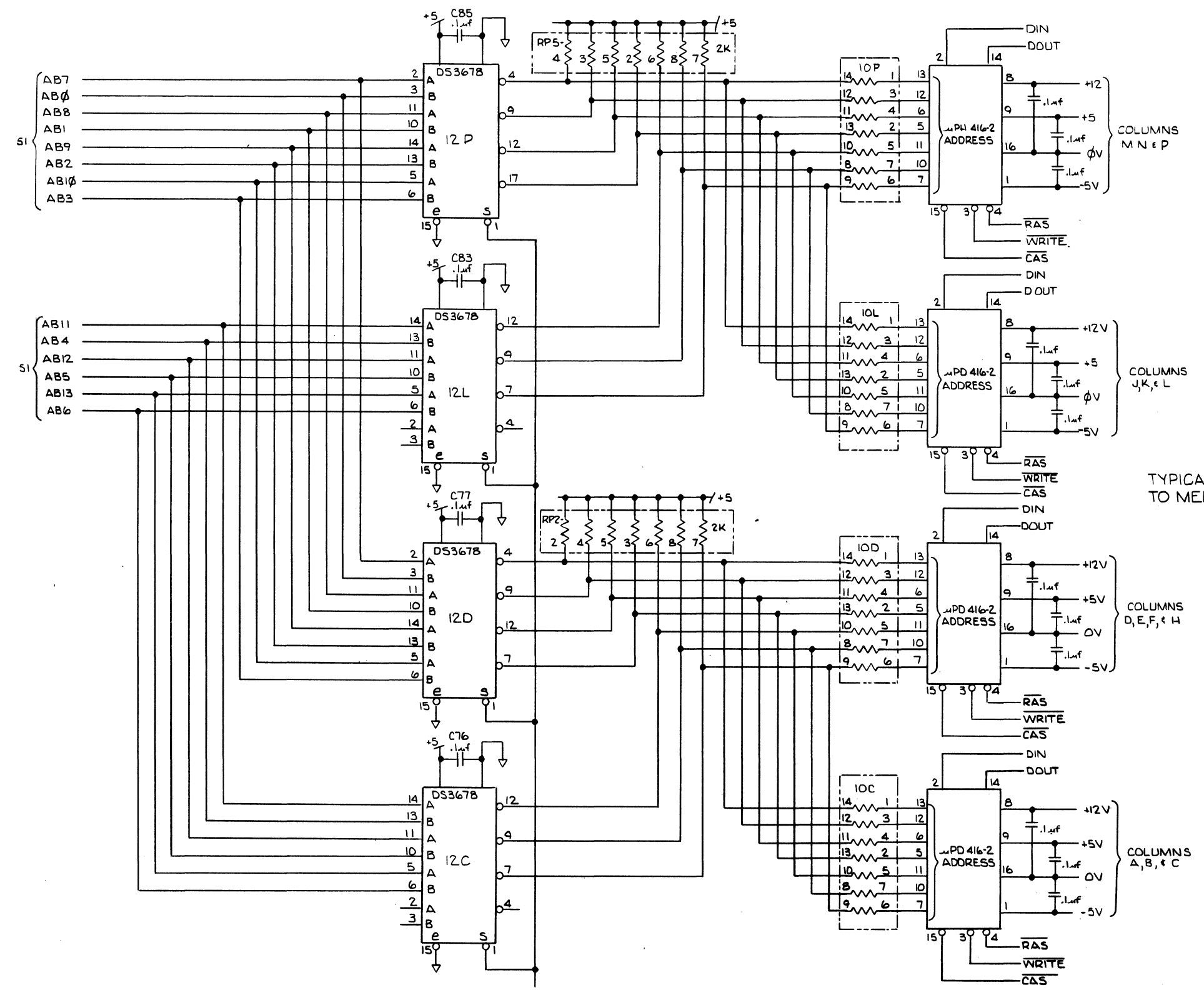

TYPICAL CONNECTIONS TO MEMORY CHIP

TOLERANCES UNLESS OTHERWISE SPECIFIED		ALLOS COMPUTER SYSTEMS	
FRACTIONS	DEC	ANGLES	
±	±	±	
APPROVALS	DATE		
DRAWN C.R.	1/24/61		
CHECKED		SCALE	SIZE DRAWING NO. D 625-11243-001
		DO NOT SCALE DRAWING	SHEET 3 of 3

REVISIONS			
LTR	DESCRIPTION	DATE	APPROVED

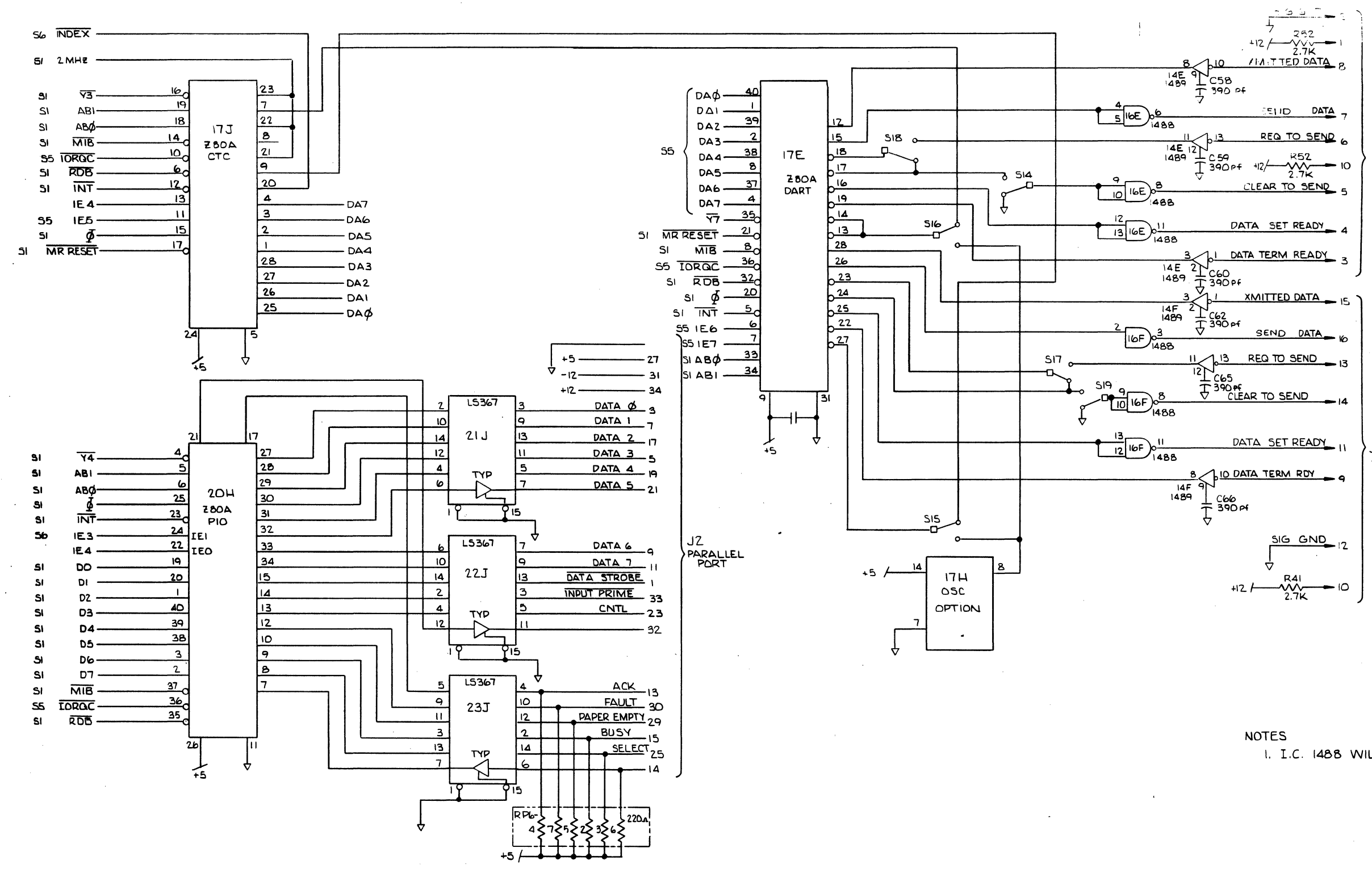

J6 CONSOLE #1 TO JX

J6 PRINTER #1 TO JT

J2 PARALLEL PORT

NOTES
 1. I.C. 1488 WILL HAVE PIN 1 TO -12
 AND PIN 14 TO +12

TOLERANCES UNLESS OTHERWISE SPECIFIED		FRACTIONS DEC ANGLES		± ± ±	
ALTOS COMPUTER SYSTEMS					
APPROVALS	DATE				
DRAWN C.R.	1/2/81	SCALE	SIZE D	DRAWING NO. 625-11243-001	4
CHECKED		DO NOT SCALE DRAWING		SHEET 4 of 8	

REVISIONS			
LTR	DESCRIPTION	DATE	APPROVED

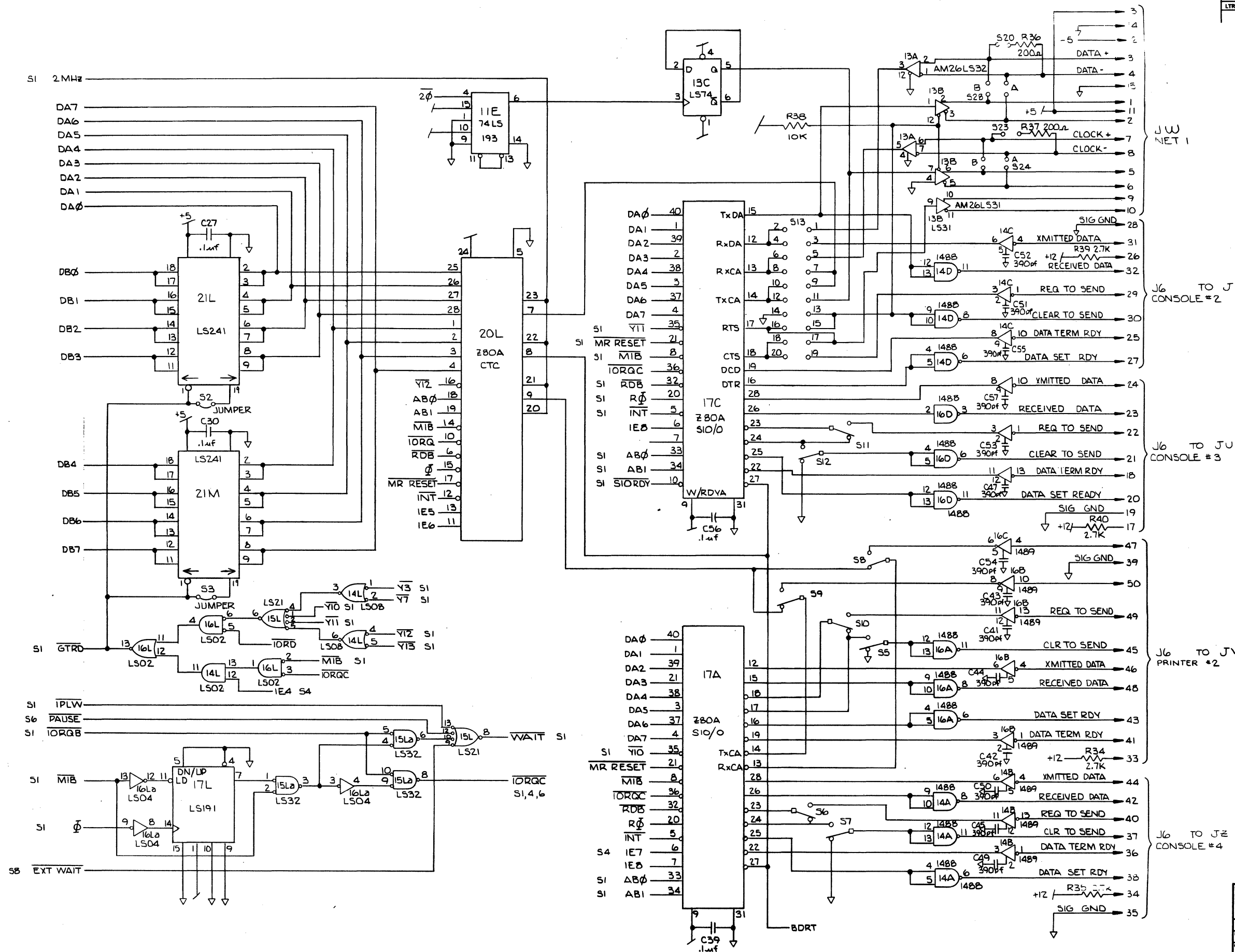

TOLERANCES UNLESS OTHERWISE SPECIFIED
 FRACTIONS DEC ANGLES
 ± ± ±

ALTO COMPUTER SYSTEMS

APPROVALS	DATE
DRAWN C.R.	1/24/81
CHECKED	

SCALE: _____ SIZE: **D** DRAWING NO.: **625-11243-001**

DO NOT SCALE DRAWING SHEET 5 of 8

REVISIONS			
LTR	DESCRIPTION	DATE	APPROVED

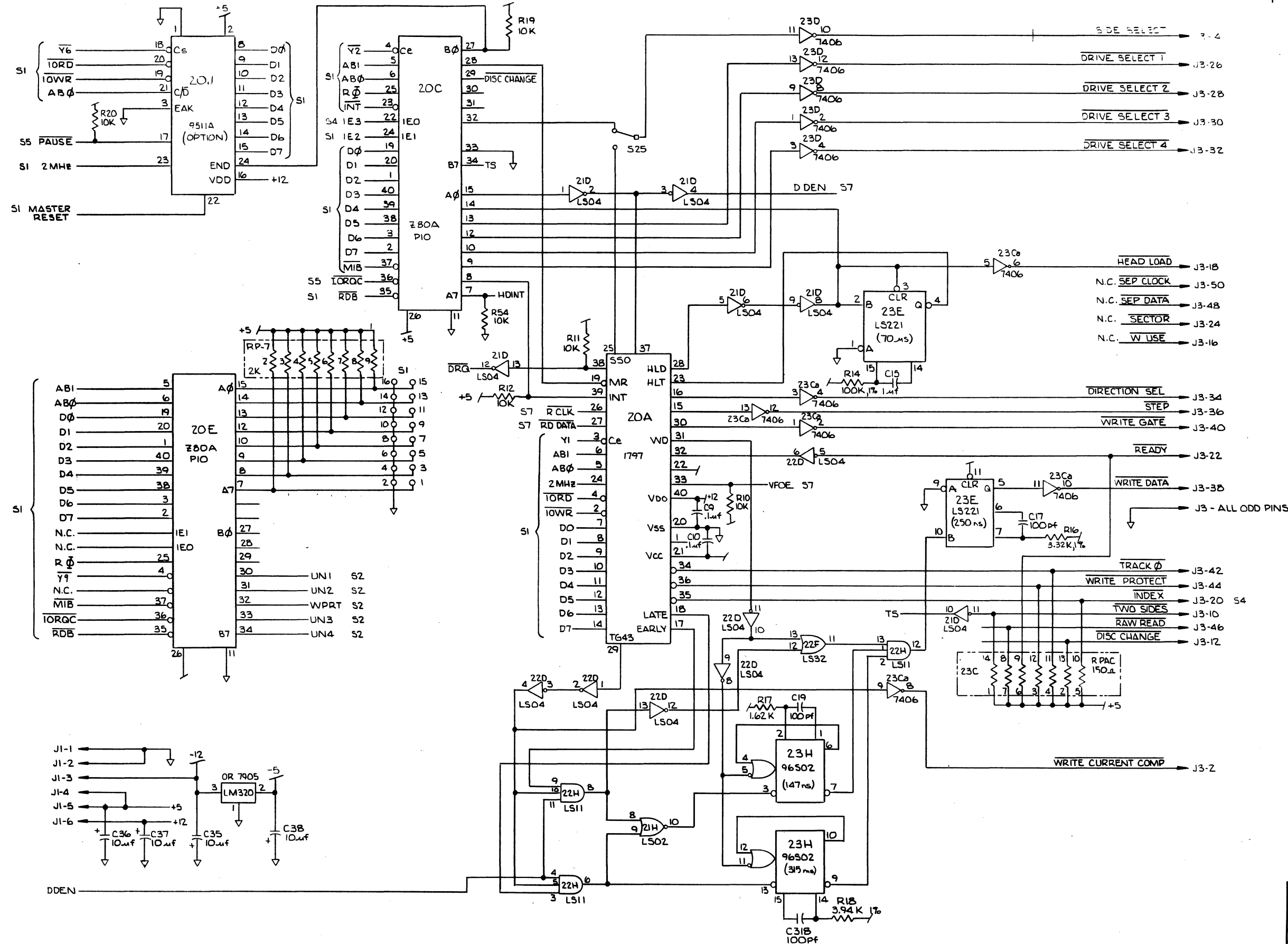

TOLERANCES UNLESS OTHERWISE SPECIFIED		ALTO'S COMPUTER SYSTEMS	
FRACTIONS	DEC	ANGLES	± ± ±
APPROVALS	DATE	SCALE	SIZE
DRAWN	1/20/81	SCALE	D
CHECKED		DRAWING NO.	625-11293-001
		DO NOT SCALE DRAWING	SHEET 6 OF 8

REVISIONS			
LTR	DESCRIPTION	DATE	APPROVED

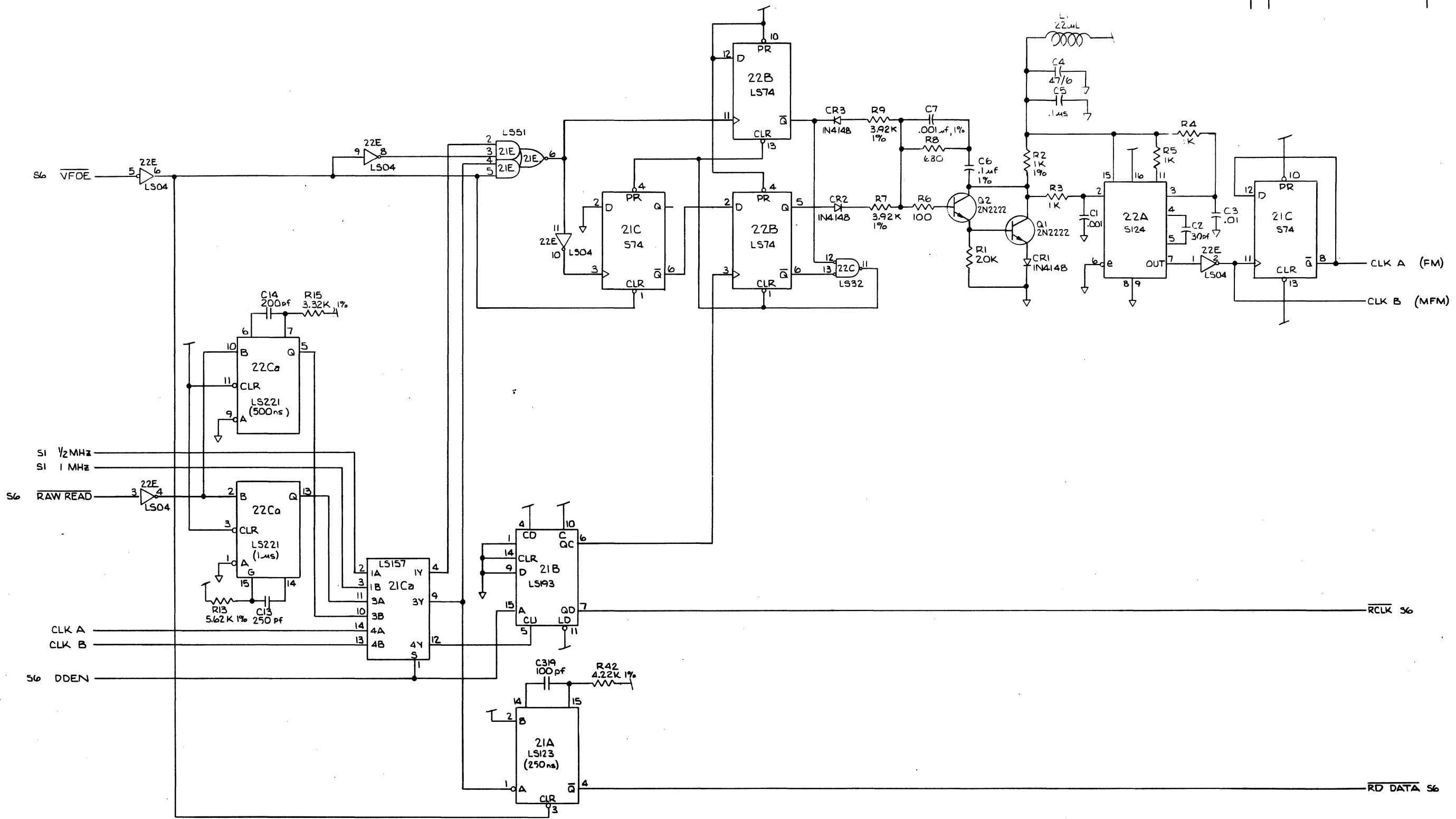

TOLERANCES UNLESS OTHERWISE SPECIFIED		ALLOS COMPUTER SYSTEMS	
FRACTIONS	DEC	ANGLES	
±	±	±	
APPROVALS	DATE	SCALE	SIZE
DRAWN	DATE		D
CHECKED			DRAWING NO.
			C.S.-11243-001 4
DO NOT SCALE DRAWING		SHEET 7 of 8	

REVISIONS			
LTR	DESCRIPTION	DATE	APPROVED

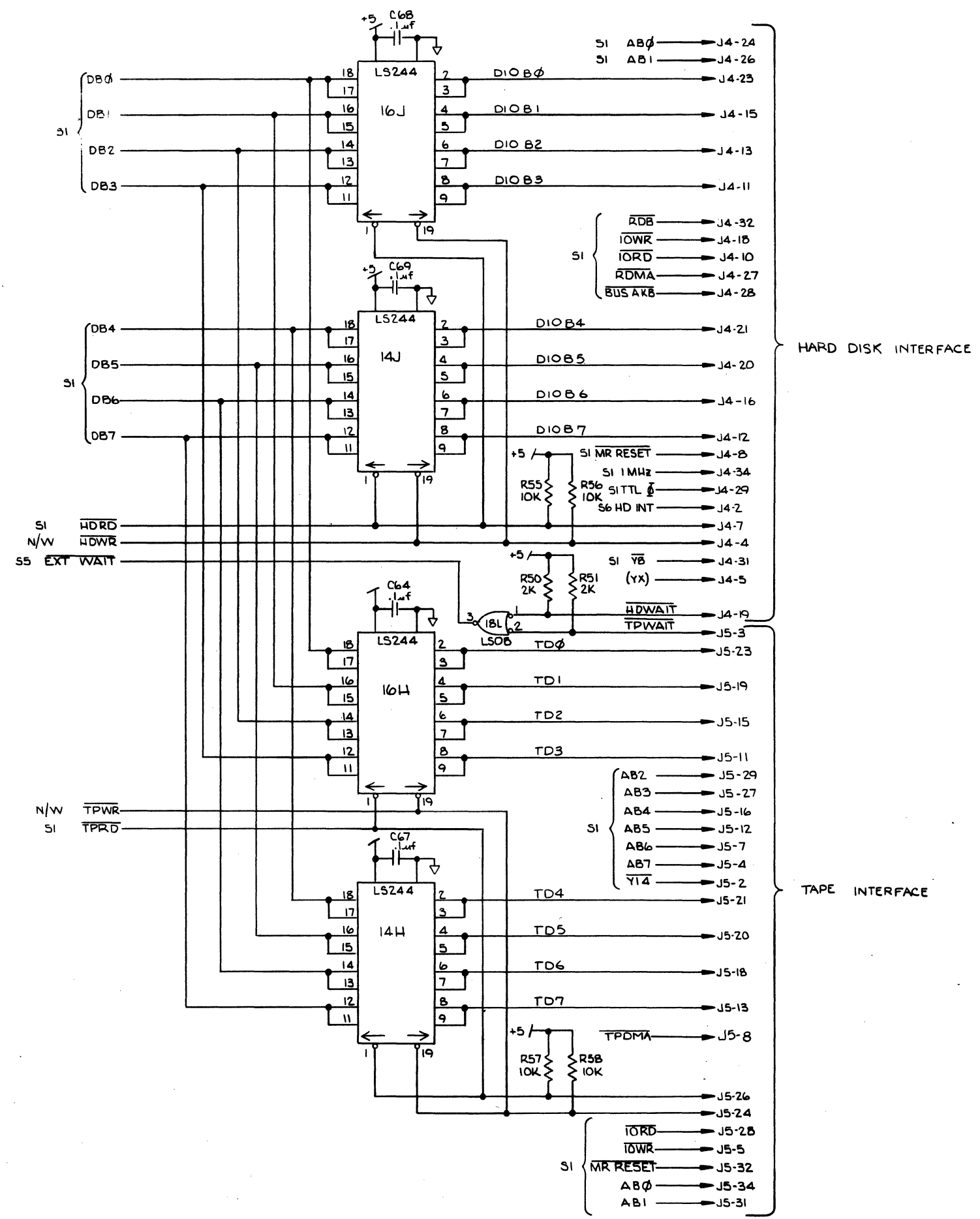

TOLERANCES UNLESS OTHERWISE SPECIFIED		FRACTIONS DEC ANGLES		± ± ±	
APPROVALS		DATE		SCALE	
DRAWN: C.R.		1/20/61		SIZE D	
CHECKED				DRAWING NO. 625-11243-001	
				DO NOT SCALE DRAWING SHEET 8 of 8	

EIGHT-INCH HARD DISK CONTROLLER SCHEMATICS

REVISIONS		DATE	APPROVED
ZONE	REV.		

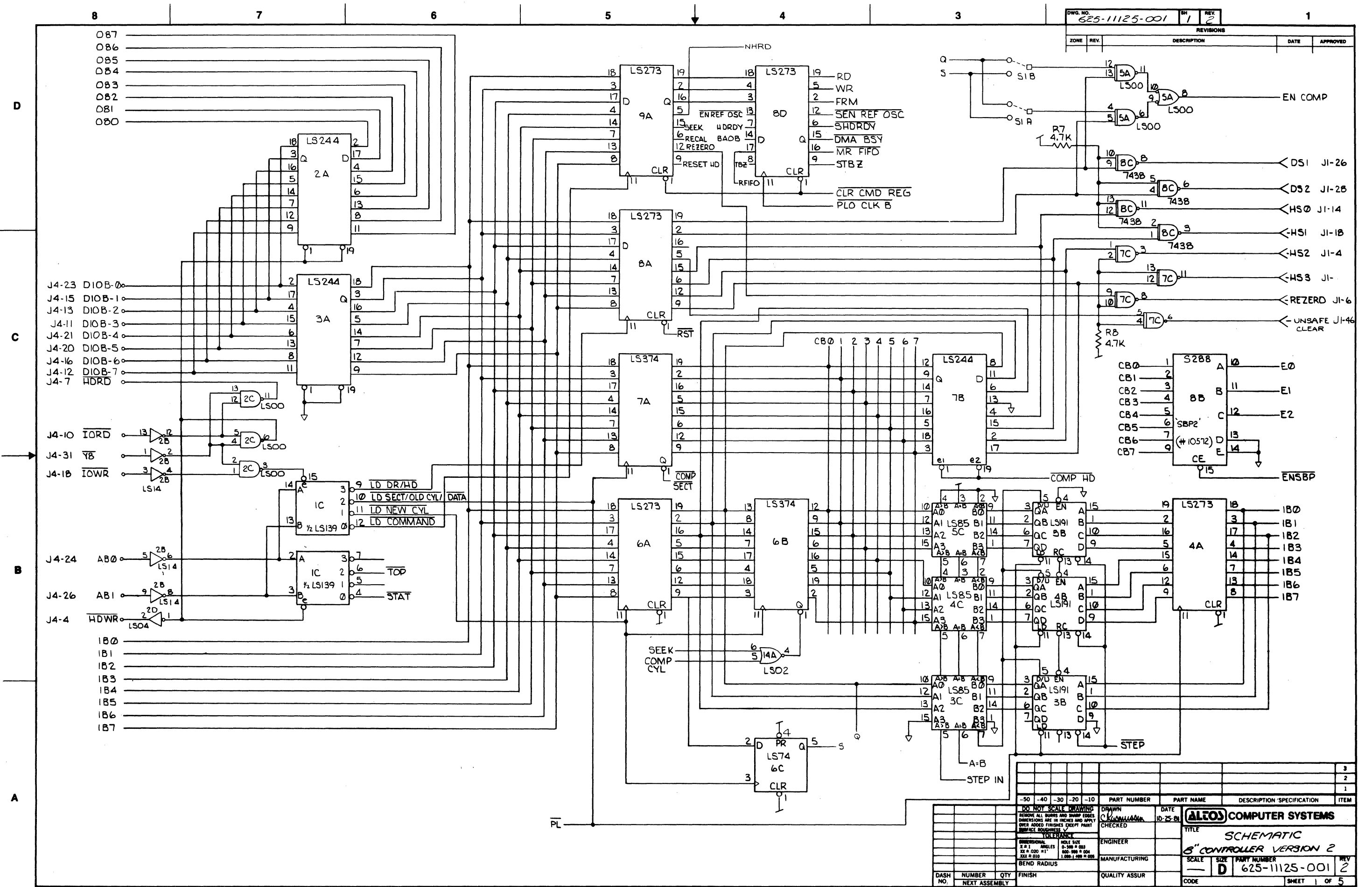

DO NOT SCALE DRAWING		DATE	ITEM			
-50	-40	-30	-20	-10		3
REMOVE ALL BURRS AND SHARP EDGES. DIMENSIONS ARE IN INCHES AND APPLY OVER HOLED FINISHES EXCEPT PART SURFACE ROUGHNESS.						2
TOLERANCE						1
DIMENSIONAL: HOLE SIZE						
X=1 ANGLES: 0-500 ± 0.03						
X=100 ± 0.04						
X=1000 ± 0.05						
BEND RADIUS						
DASH NO.	NUMBER	QTY	FINISH	QUALITY ASSUR		
		NEXT ASSEMBLY				

PART NUMBER	PART NAME	DESCRIPTION	SPECIFICATION
ALTO'S COMPUTER SYSTEMS			
TITLE: SCHEMATIC			
8" CONTROLLER VERSION 2			
SCALE	SIZE	PART NUMBER	REV
	D	625-11125-001	2
CODE			SHEET 1 OF 5

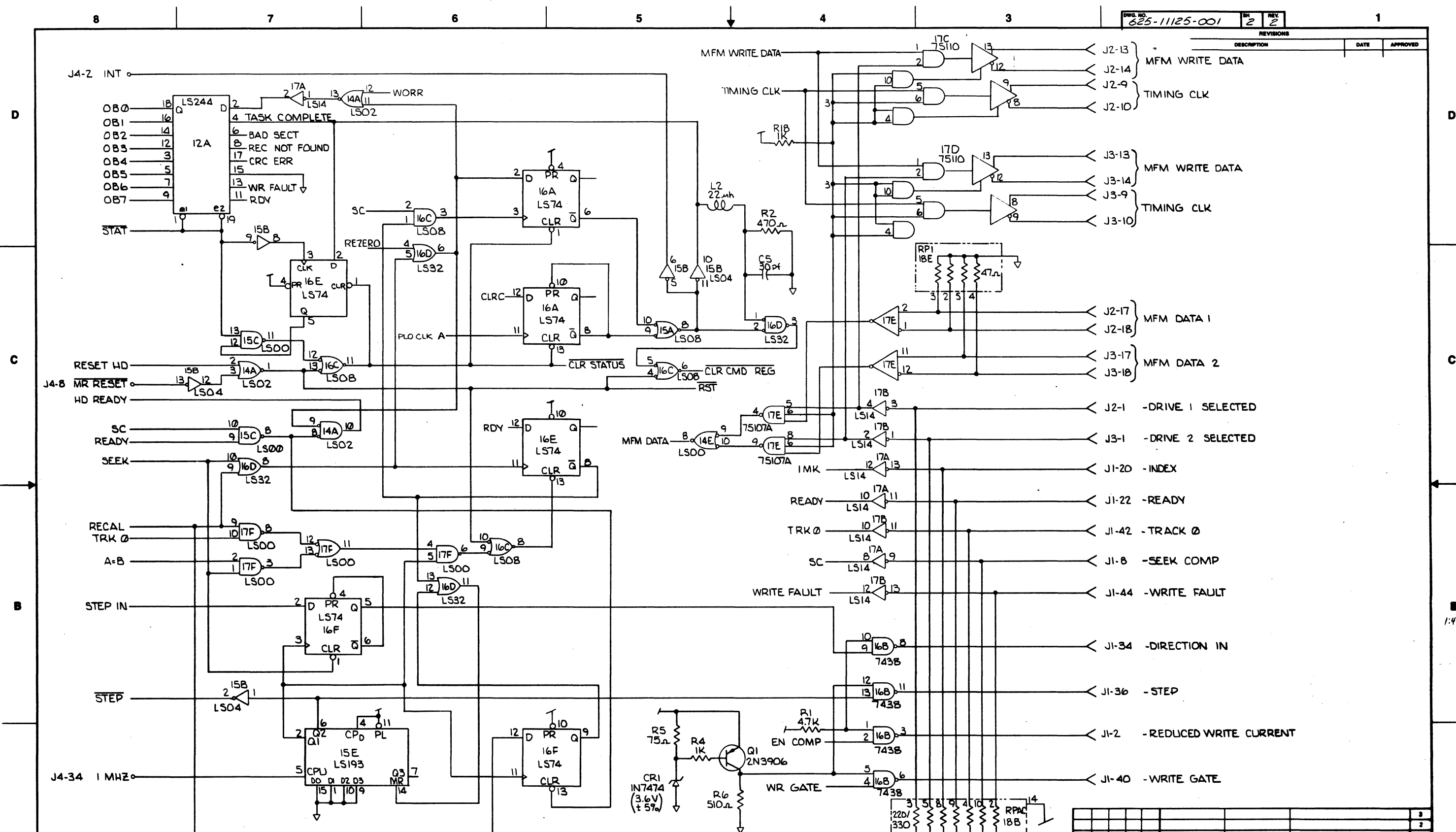

B
1:45
A

REV	DESCRIPTION	DATE	APPROVED
2		10-25-81	
1			

DASH NO.	NUMBER	QTY	FINISH	DESCRIPTION/SPECIFICATION	ITEM
				ALLOS COMPUTER SYSTEMS	3
				SCHEMATIC	2
				3" CONTROLLER VERSION 2	1
				SCALE	
				SIZE	
				PART NUMBER	
				REV	
				D 625-11125-001	2
				SHEET 2 OF 5	

BISHOP GRAPHICS/ACCUPRESS
REORDER NO. AT1218

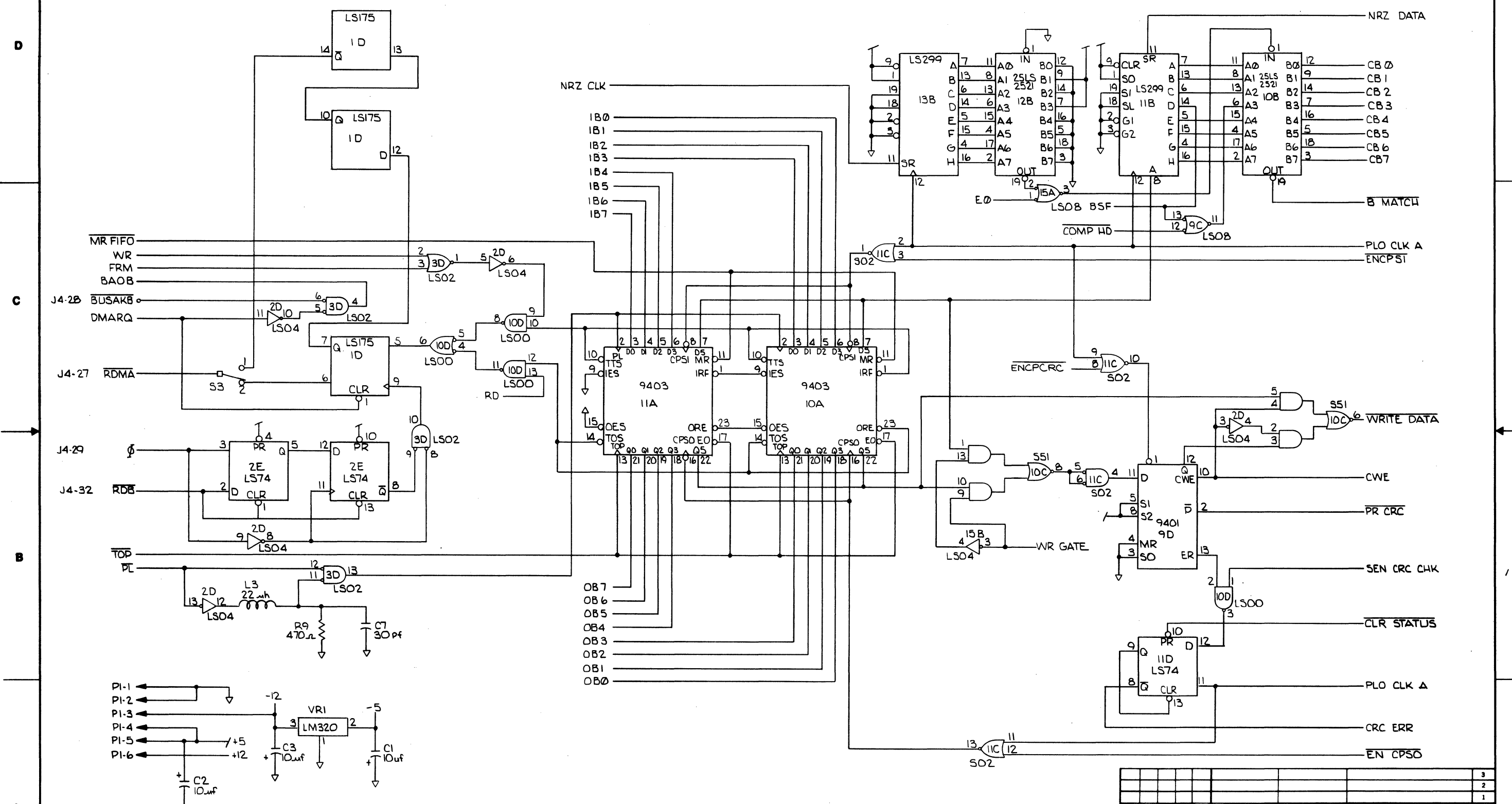

DASH NO.	NUMBER	QTY	FINISH	QUALITY ASSUR	SCALE	SIZE	PART NUMBER	REV
					D		625-1125-001	2

50	40	30	20	10	PART NUMBER	PART NAME	DESCRIPTION / SPECIFICATION	ITEM
								3
								2
								1

DO NOT SCALE DRAWING REMOVE ALL BURRS AND SHARP EDGES DIMENSIONS ARE IN INCHES AND APPLY OVER ADDED FINISHES EXCEPT PAINT SURFACE FINISHES.		DRAWN	DATE
TOLERANCE DIMENSIONAL X ± .1 XX ± .020 XXX ± .010		CHECKED	
HOLE SIZE 1" - 199 ± .003 2" - 199 ± .004 3" - 199 ± .005		ENGINEER	
BEND RADIUS		MANUFACTURING	
		QUALITY ASSUR	

ALCOS COMPUTER SYSTEMS TITLE SCHEMATIC 3" CONTROLLER VERSION 2	
SCALE	PART NUMBER
D	625-1125-001
REV	2
SHEET 3 OF 5	

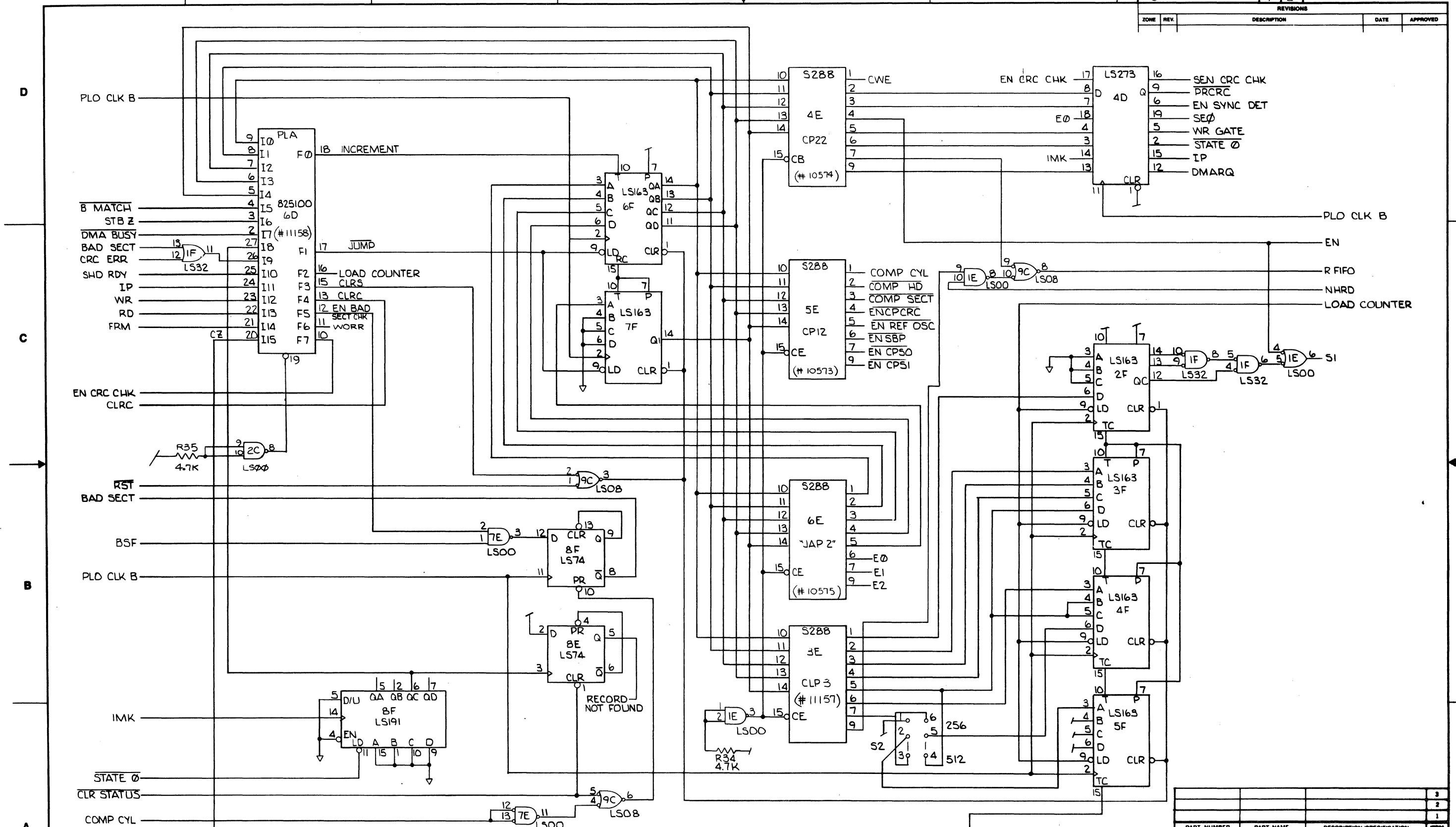

PART NUMBER	PART NAME	DESCRIPTION / SPECIFICATION	ITEM
			3
			2
			1

DO NOT SCALE DRAWING		DATE	10/25/81
REMOVE ALL BURRS AND SHARP EDGES		ENGINEER	
DIMENSIONS ARE IN INCHES AND APPLY		MANUFACTURING	
OVER HOLED FINISHES CHECKY PAINT		QUALITY ASSUR	
SURFACE ROUGHNESS			
TOLERANCE			
DIMENSIONAL			
HOLE SIZE			
ANGLES			
BEND RADIUS			
DASH NO.	NUMBER	QTY	FINISH
	NEXT ASSEMBLY		

ALLOS COMPUTER SYSTEMS			
TITLE			
8" CONTROLLER VERSION 2			
SCALE	SIZE	PART NUMBER	REV
	D	625-11125-001	2
CODE			SHEET 4 OF 5

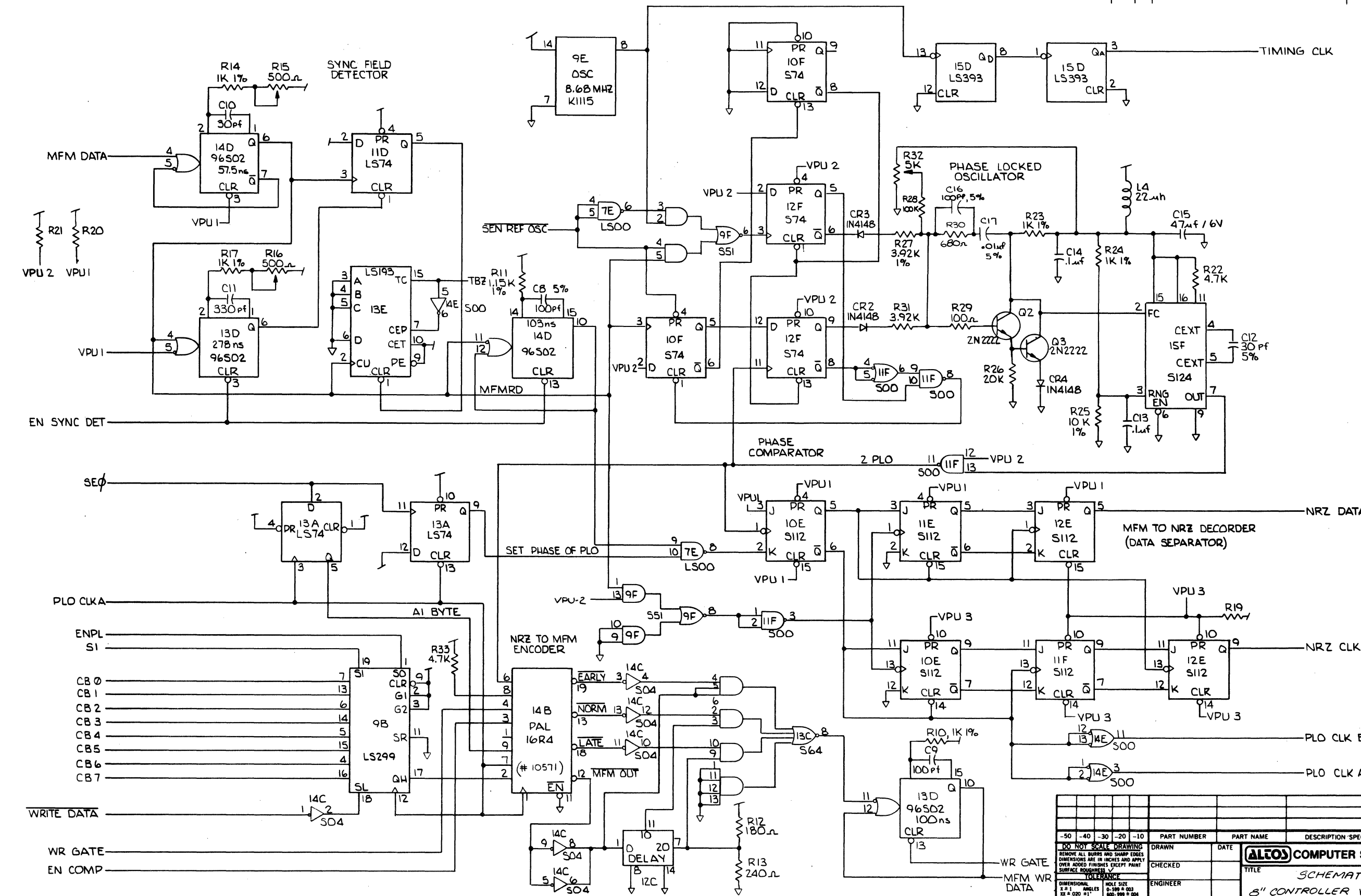

DO NOT SCALE DRAWING		DRAWN		DATE	
REMOVE ALL BURRS AND SHARP EDGES					
DIMENSIONS ARE IN INCHES AND APPLY OVER ADDED FINISHES EXCEPT PAINT					
SURFACE ROUGHNESS					
TOLERANCES					
DIMENSIONAL		HOLE SIZE			
X ± .1		0-.999 ± .003			
X ± .020 ± .01		1.000 ± .004			
X ± .010		1.000-1.999 ± .005			
BEND RADIUS					
DASH NO.	NUMBER	QTY	FINISH	QUALITY ASSUR	SCALE
	NEXT ASSEMBLY				SIZE
					PART NUMBER
					REV
					CODE

ALTO'S COMPUTER SYSTEMS
TITLE: SCHEMATIC
3" CONTROLLER VERSION 2
SCALE: ~ D 625-11125-001 ?
SHEET 5 OF 5

XENTEK POWER SUPPLY SCHEMATICS

REVISIONS			
REV	BY	DESCRIPTION	APPR DATE
A	Bz	INITIAL RELEASE	t

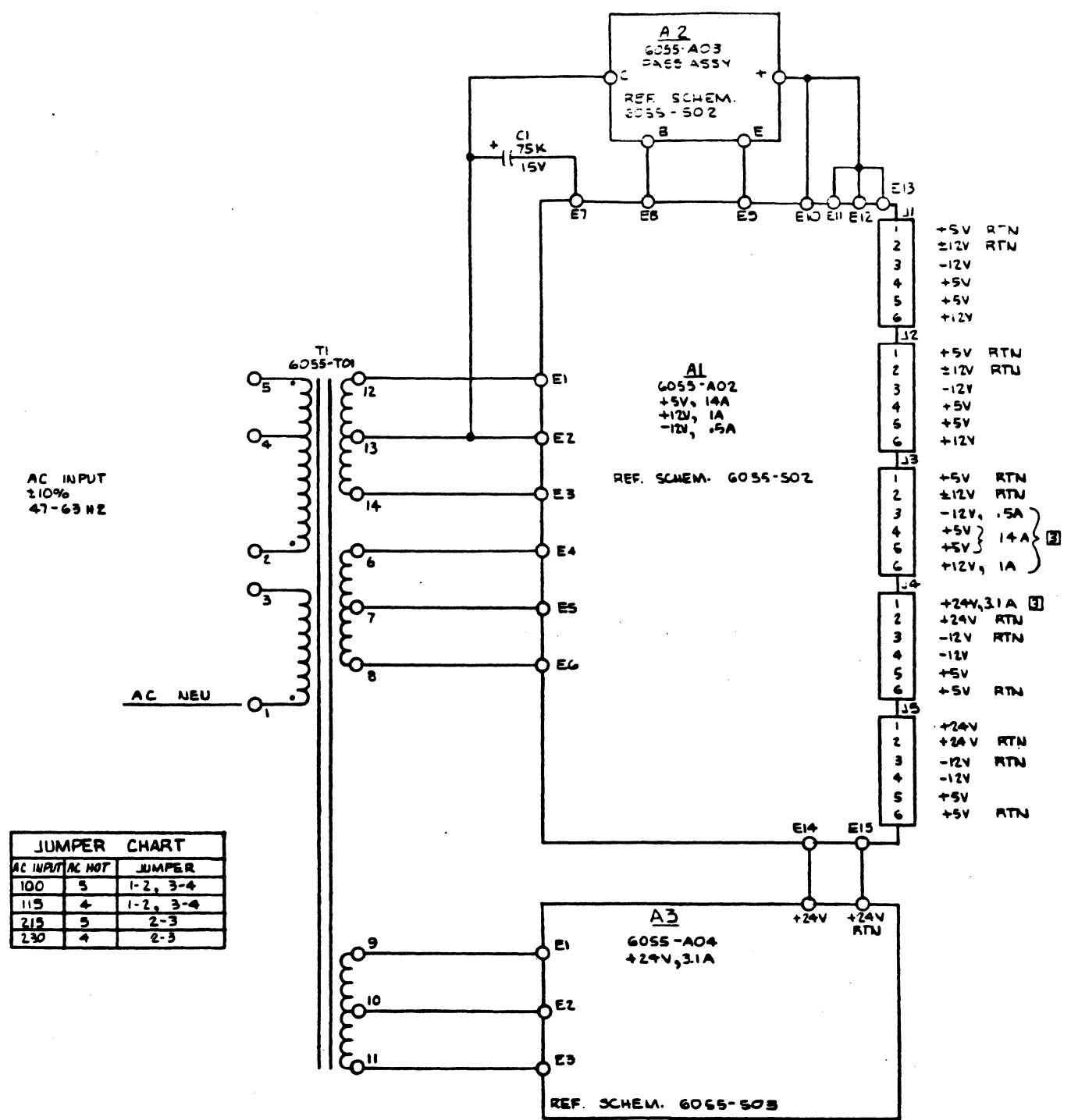

AC INPUT	AC HOT	JUMPER
100	5	1-2, 3-4
115	4	1-2, 3-4
215	5	2-3
230	4	2-3

3 TOTAL CURRENT SUPPLIED BY ALL CONNECTORS.
 2. ALL CAPACITANCE VALUES IN MICROFARADS
 1. REF. DOCUMENTS: 6055-501, 6055-502, 6055-503
 NOTES: UNLESS OTHERWISE SPECIFIED.

QTY REQ'D	DESCRIPTION	PART NO.	MATERIAL	MANUFACTURER	ITEM NO.
LIST OF MATERIAL					
UNLESS OTHERWISE SPECIFIED DIMENSIONS ARE IN INCHES		SIGNATURES		DATES	
TOLERANCES		CHK.		12-1980	
FRAC.	DEC.	ANGLES	TITLE		
±.015	.XX ±.02	±1/2°	XENTEK INCORPORATED		
±.030	.XXX ±.030	±1/4°	San Marcos, California		
MATERIAL:		PROPRIETARY NOTICE		11/17/80	
FINISH:		ALL PATENT OR OTHER PROPRIETARY RIGHTS PERTAINING TO THE ITEMS SOLD HEREUNDER SHALL REMAIN THE SOLE PROPERTY OF XENTEK INCORPORATED EXCEPT THAT THE PURCHASER SHALL HAVE THE RIGHT TO USE SUCH ITEMS FOR THE INTENDED PURPOSE		12/1980	
		DO NOT SCALE DWG		SCALE: NONE WEIGHT: ~ SHEET 1 OF 1	
		CODE IDENT	SIZE	DWG. NO.	REV.
		53279	D	6055-501	A

REV.		BY		DESCRIPTION		APPR.	DATE
1				INITIAL RELEASE			
A	02			REVISED - ADDED CONNECTORS J1-J5			5/80

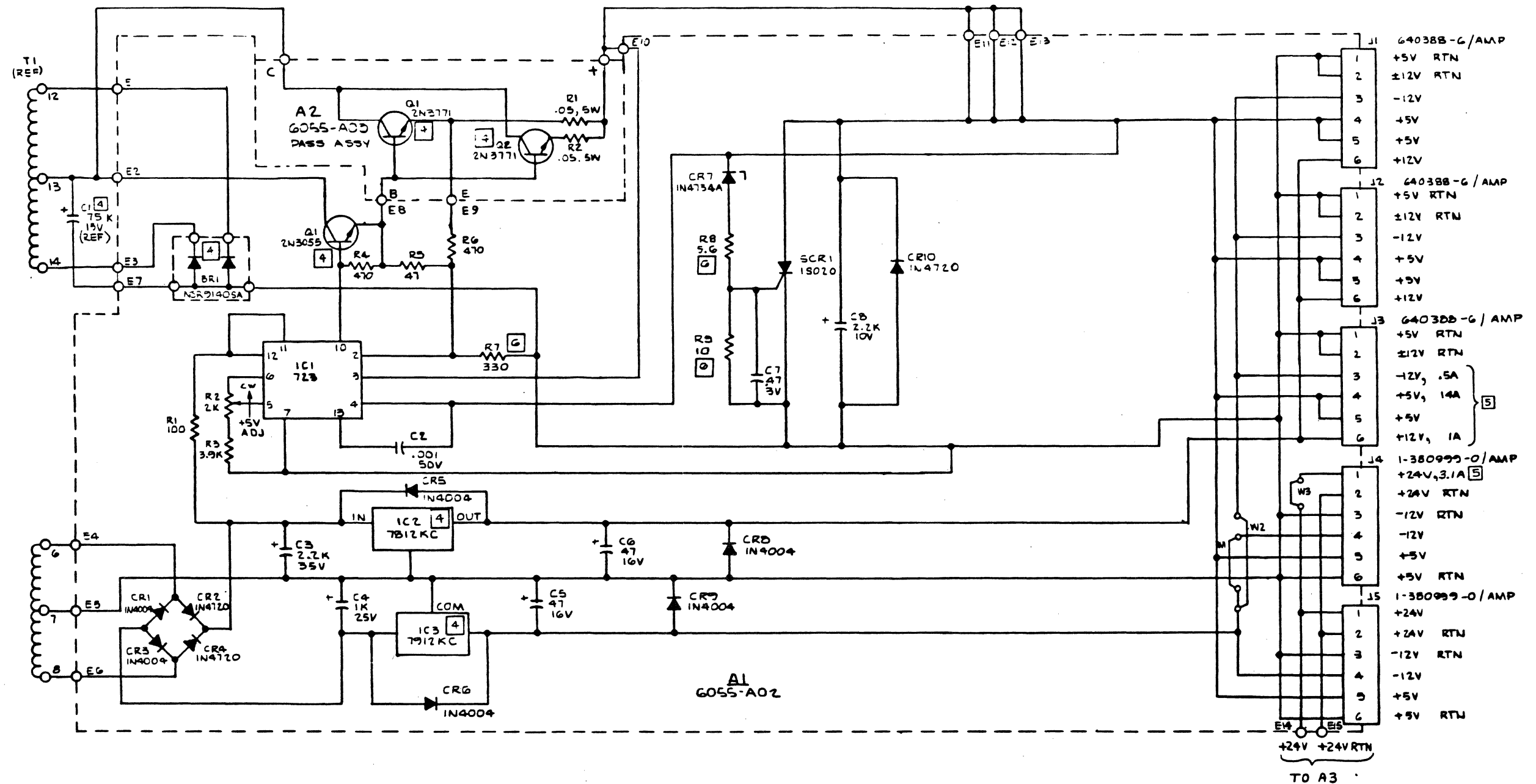

- ⑥ COMPONENT TEST SELECT
 - ⑤ TOTAL CURRENT SUPPLIED BY ALL CONNECTORS.
 - ④ COMPONENT MOUNTED ON HEATSINK OR CHASSIS.
 - 3. ALL RESISTANCE VALUES IN OHMS ±5% 1/2W.
 - 2. ALL CAPACITANCE VALUES IN MICROFARADS.
 - 1. REF. DOCUMENTS: 6055-802, 6055-803, 6055-801.
- NOTES: UNLESS OTHERWISE SPECIFIED.

QTY REQ'D	DESCRIPTION	PART NO.	MATERIAL	MANUFACTURER	ITEM NO.
LIST OF MATERIAL					
UNLESS OTHERWISE SPECIFIED DIMENSIONS ARE IN INCHES		SIGNATURES		DATES	
TOLERANCES		DWN. B. Glick		10/6/80	
FRAC. DEC. ANGLES		CHK.			
1/32 .001 1/16 .002 1/8 .005 3/16 .010 1/4 .015 3/8 .020 1/2 .030 3/4 .040 1 .050 2 .075 3 .100		DGN.		TITLE	
MATERIAL:		ENGR. A. P. [Signature]		10/6/80	
FINISH:		APPR. A. [Signature]		80	
		PROPRIETARY NOTICE		REGULATOR SCHEMATIC (ALTOS COMPUTER)	
		ALL PATENT OR OTHER PROPRIETARY RIGHTS PERTAINING TO THE ITEMS SOLD HEREUNDER SHALL REMAIN THE SOLE PROPERTY OF XENTEK INCORPORATED EXCEPT THAT THE PURCHASER SHALL HAVE THE RIGHT TO USE SUCH ITEMS FOR THEIR INTENDED PURPOSE		CODE IDENT	
		DO NOT SCALE DWG		SCALE: NONE WEIGHT: SHEET OF 1	
		XENTEK INCORPORATED San Marcos, California		Dwg. No. 6055-802	
		REV. A		REV. A	

6055-S02 | A

REVISIONS			
REV.	BY	DESCRIPTION	APPR. DATE
NC	32	INITIAL RELEASE	5/1/68

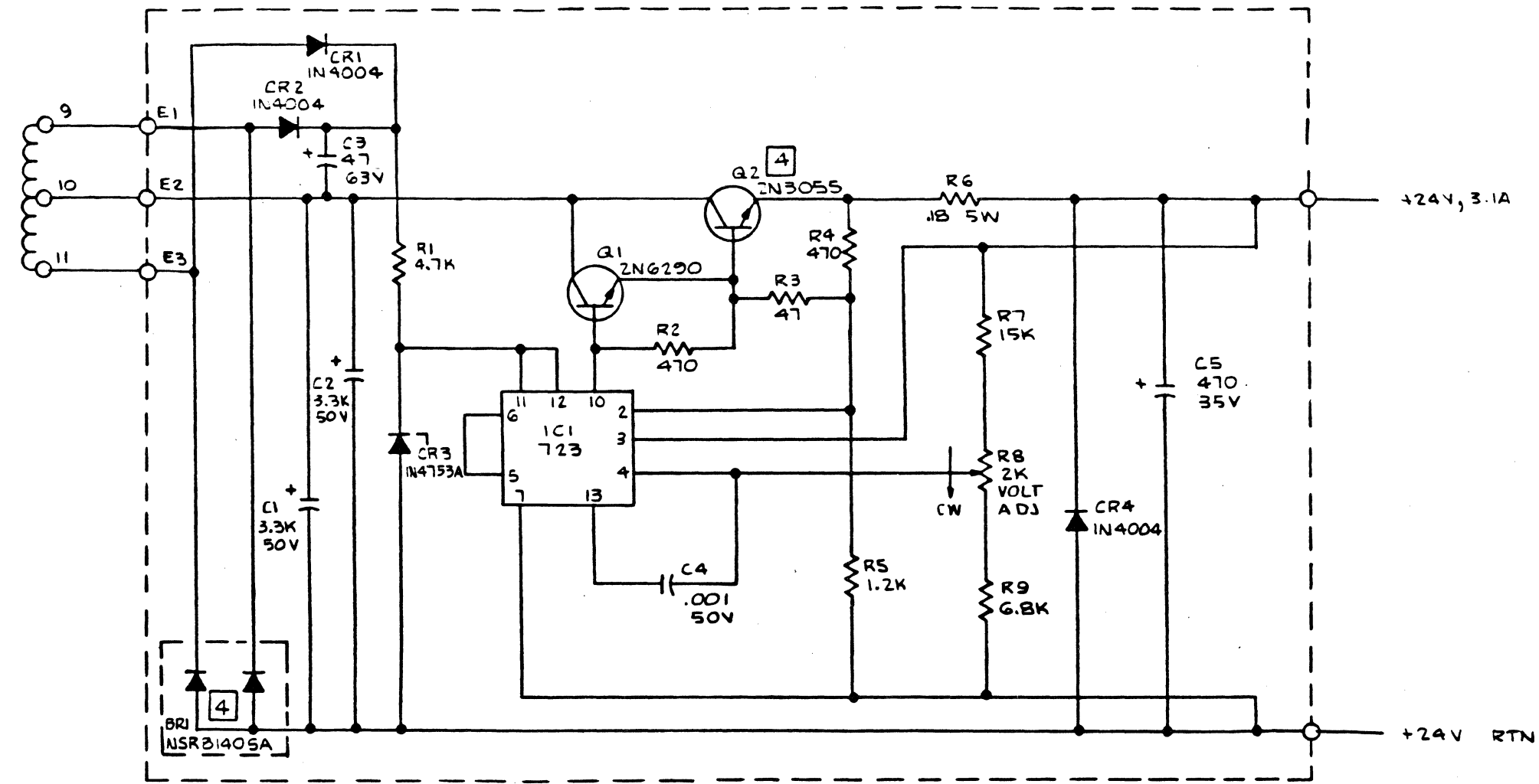

- 4. COMPONENT MOUNTED ON HEATSINK
 - 3. ALL RESISTANCE VALUES IN OHMS $\pm 5\%$, 1/2W.
 - 2. ALL CAPACITANCE VALUES IN MICROFARADS.
 - 1. REF. DOCUMENTS: G055-B04, G055-S01.
- NOTES: UNLESS OTHERWISE SPECIFIED.

QTY REQ'D	DESCRIPTION	PART NO.	MATERIAL	MANUFACTURER	ITEM NO.
LIST OF MATERIAL					
UNLESS OTHERWISE SPECIFIED DIMENSIONS ARE IN INCHES		SIGNATURES		DATES	
TOLERANCES		DWN. <i>P. J. J.</i>		25-80	
FRAC. DEC. ANGLES		CHK.		TITLE	
$\pm 1/32$.XX $\pm .02$ $\pm 1/2^\circ$		DSGN. <i>P. J. J.</i>		REGULATOR	
		ENGR. <i>P. J. J.</i>		SCHEMATIC	
		APPR. <i>P. J. J.</i>		(ALTOS)	
MATERIAL:		PROPRIETARY NOTICE			
FINISH:		ALL PATENT OR OTHER PROPRIETARY RIGHTS PERTAINING TO THE ITEMS SOLD HEREUNDER SHALL REMAIN THE SOLE PROPERTY OF XENTEK INCORPORATED EXCEPT THAT THE PURCHASER SHALL HAVE THE RIGHT TO USE SUCH ITEMS FOR THEIR INTENDED PURPOSE.			
		CODE IDENT	SIZE	DWG. NO.	REV.
		53279	C	6055-S03	NC
		DO NOT SCALE DWG.		SCALE: NONE	WEIGHT: ~ SHEET 1 OF 1

6055-S03 NC

REAR PANEL I/O PCB SCHEMATIC

REVISIONS			
LTR	DESCRIPTION	DATE	APPROVED

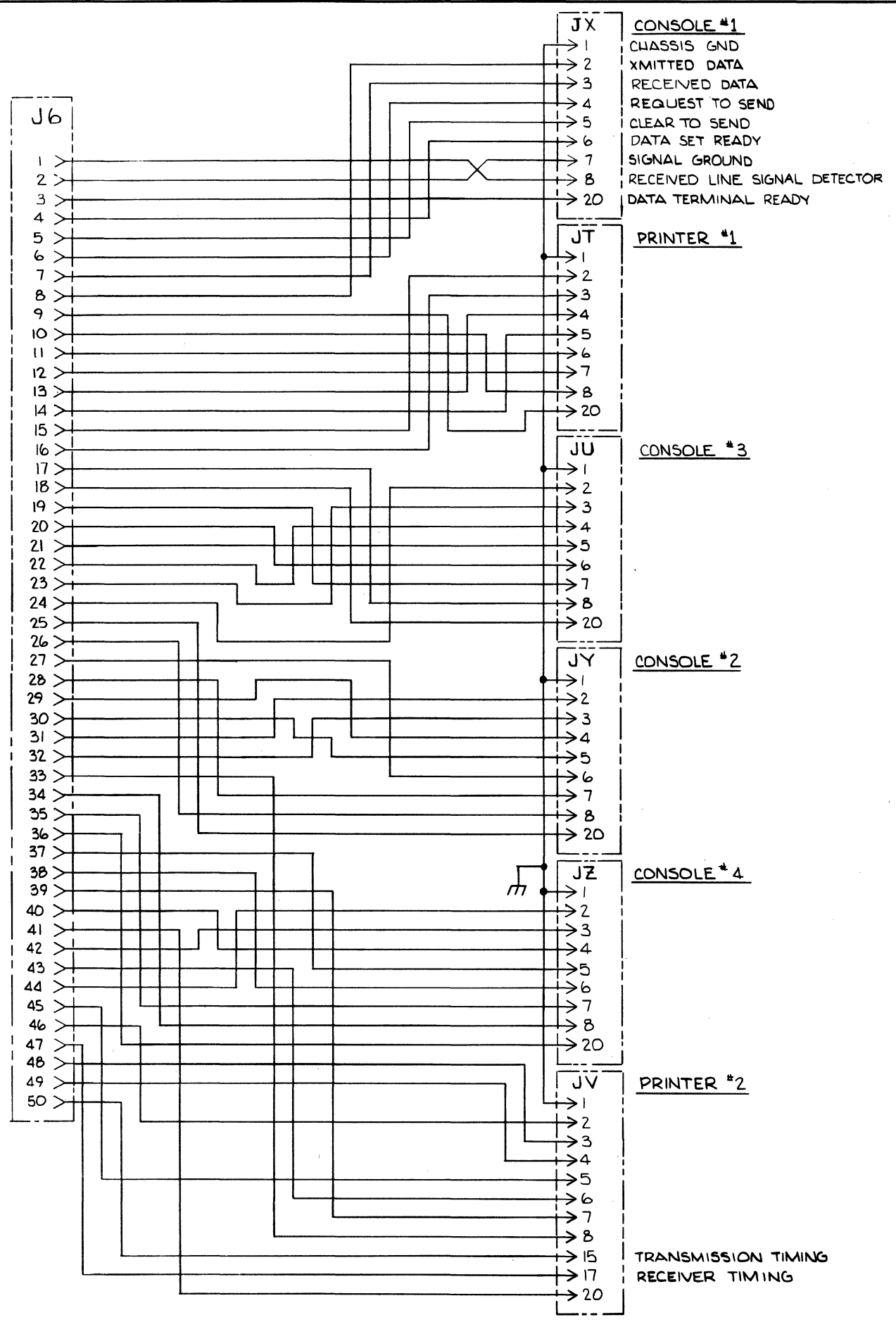

TOLERANCES UNLESS OTHERWISE SPECIFIED		FRACTIONS DEC ANGLES		± ± ±		ALTOS COMPUTERS	
APPROVALS	DATE	SCHEMATIC, I/O PCB		SCALE	SIZE	DRAWING NO.	A
DRAWN	CHECKED	~	D	8500-0016	SHEET 1 OF 1		

SHUGART SA1000 SCHEMATICS

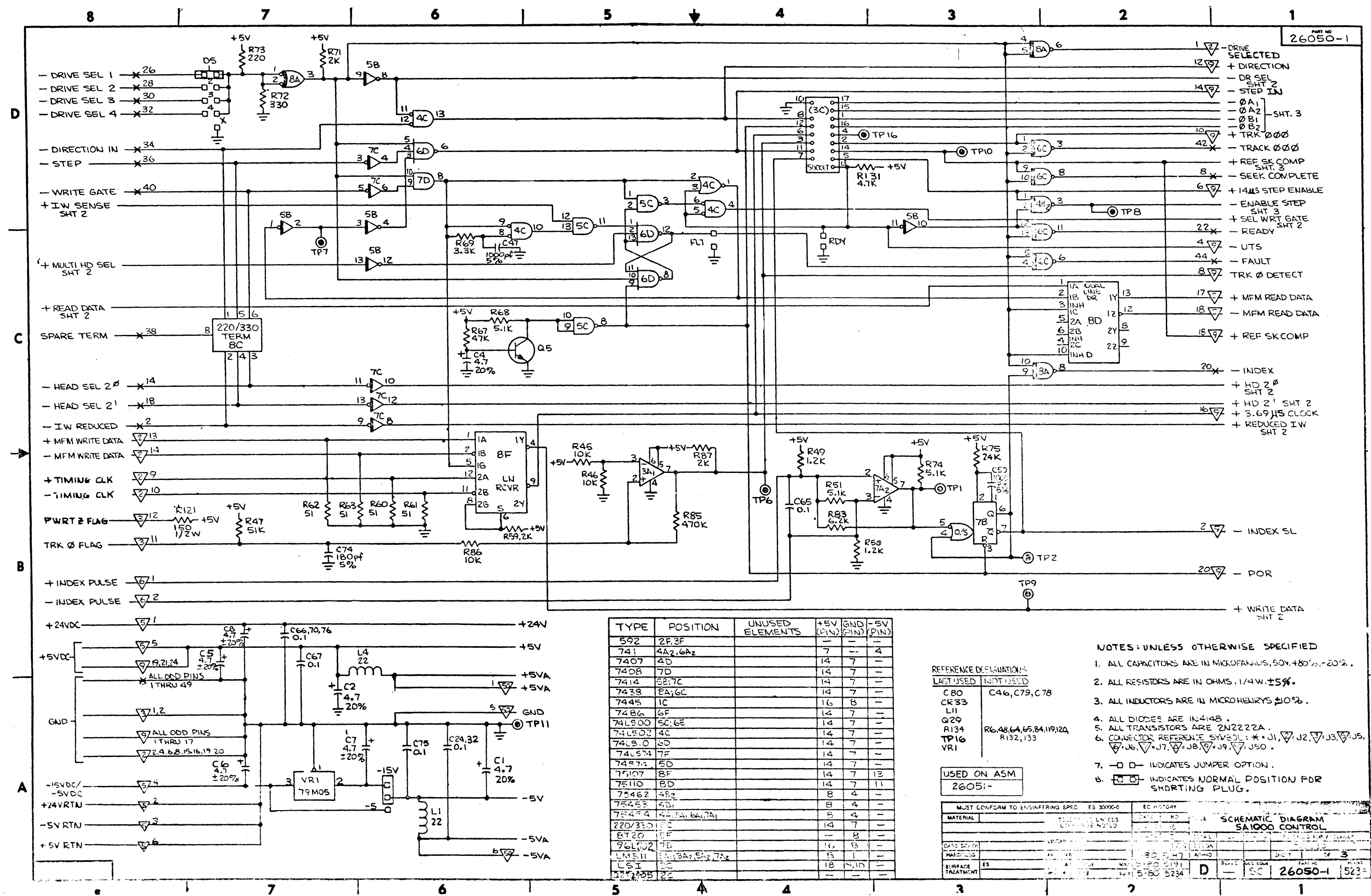

TYPE	POSITION	UNUSED ELEMENTS	+5V (PIN)	GND (PIN)	-5V (PIN)
592	2F,3F				
741	4A2,6A2		7		4
7407	4D		14	7	
7408	7D		14	7	
7414	5B,7C		14	7	
7438	8A,6C		14	7	
7445	1C		14	7	
7486	6F		14	7	
74LS00	5C,6E		14	7	
74LS02	4C		14	7	
74LS10	6D		14	7	
74LS14	7F		14	7	
74LS15	5D		14	7	
75107	8F		14	7	13
75110	8D		14	7	11
75462	4B2		8	4	
75463	4B1		8	4	
75464	4B1,6A1,7A1		8	4	
220/330	8C		14	7	
8T20	8F			8	
96LS02	7B		16	8	
LMS11	8A,8A2,8A3,7A2		5	1	
LSI	8C		18	1,10	
592,435	2C				

REFERENCE DESIGNATIONS:
 LAST USED NOT USED
 C80 C46,C79,C78
 CR33 L11
 Q29 R6,48,64,65,84,119,120,
 TP16 R132,133
 VRI

USED ON ASM
 26051-

- NOTES: UNLESS OTHERWISE SPECIFIED
1. ALL CAPACITORS ARE IN MICROFARADS, 50V, ±20%.
 2. ALL RESISTORS ARE IN OHMS, 1/4W, ±5%.
 3. ALL INDUCTORS ARE IN MICROHENRYS ±10%.
 4. ALL DIODES ARE IN-4148.
 5. ALL TRANSISTORS ARE 2N2222A.
 6. CONNECTOR REFERENCE SYMBOL: * - J1, ▽ - J2, ▽ - J3, ▽ - J5, ▽ - J6, ▽ - J7, ▽ - J8, ▽ - J9, ▽ - J50.
 7. - D D - INDICATES JUMPER OPTION.
 8. INDICATES NORMAL POSITION FOR SHORTING PLUG.

MUST CONFORM TO ENGINEERING SPEC. ES 30000-0		EC HISTORY	
MATERIAL	TESTING UNITS	DATE	NO.
SCHEMATIC DIAGRAM SA1000 CONTROL			
CASE DESIGN	LINEAR		
MANUFACTURE			
SURFACE TREATMENT			
		REV. 3	
		DATE	3/83
		BY	SC
		26050-1	523

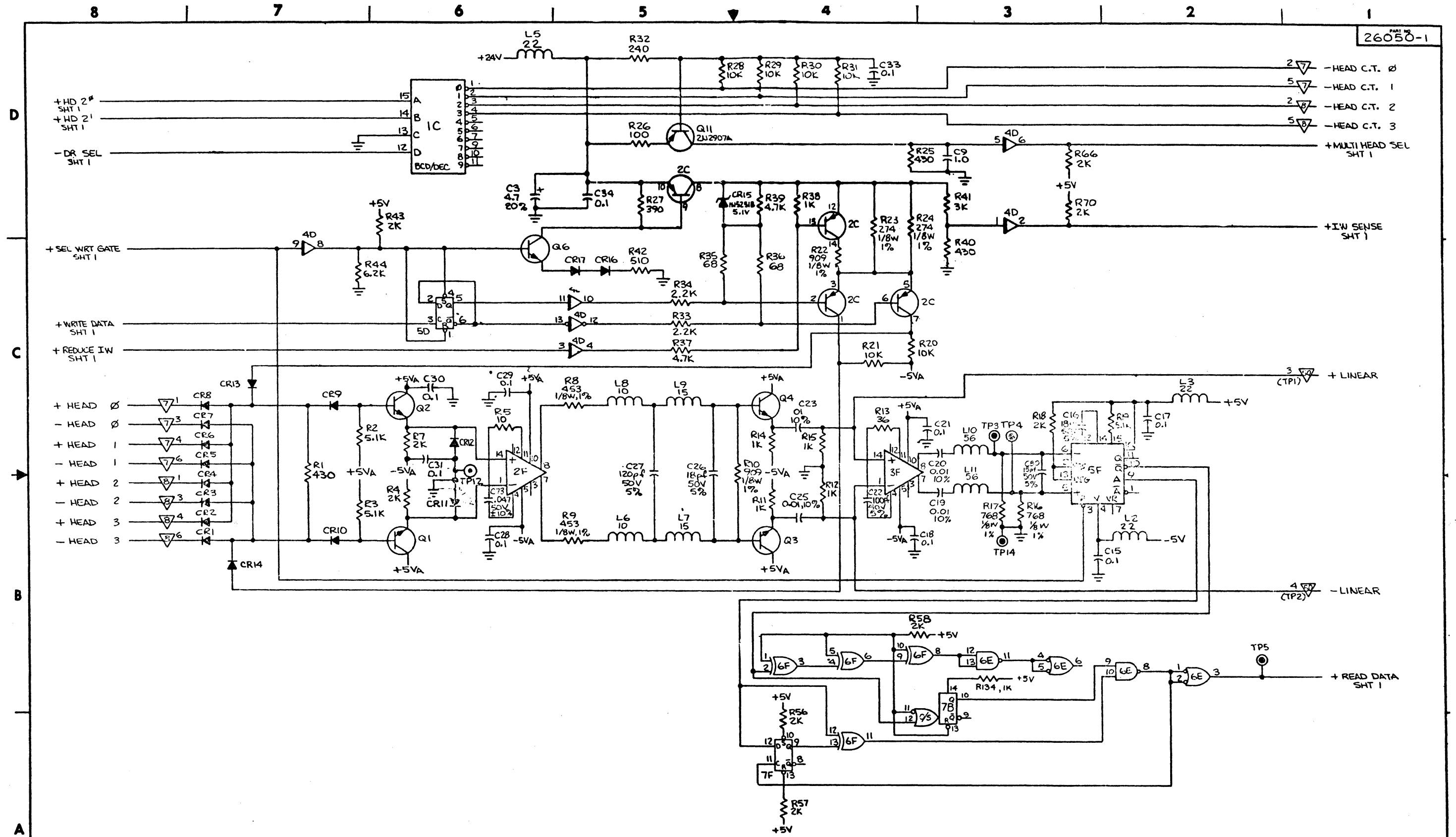

MUST CONFORM TO ENGINEERING SPEC. ES 30000-0		EC HISTORY		TITLE		
MATERIAL	TOLERANCE UNLESS OTHERWISE NOTED	DATE	BY	SCHEMATIC DIAGRAM		
CASE DEPTH	LINEAR 1/8X			SA1000 CONTROL		
HARDNESS	ANIL 150			DESIGN	DATE	REVISED FOR ASSEMBLY
SURFACE TREATMENT	ES			APPROV		SHEET 2 OF 3
				D	SC	26050-1 15234

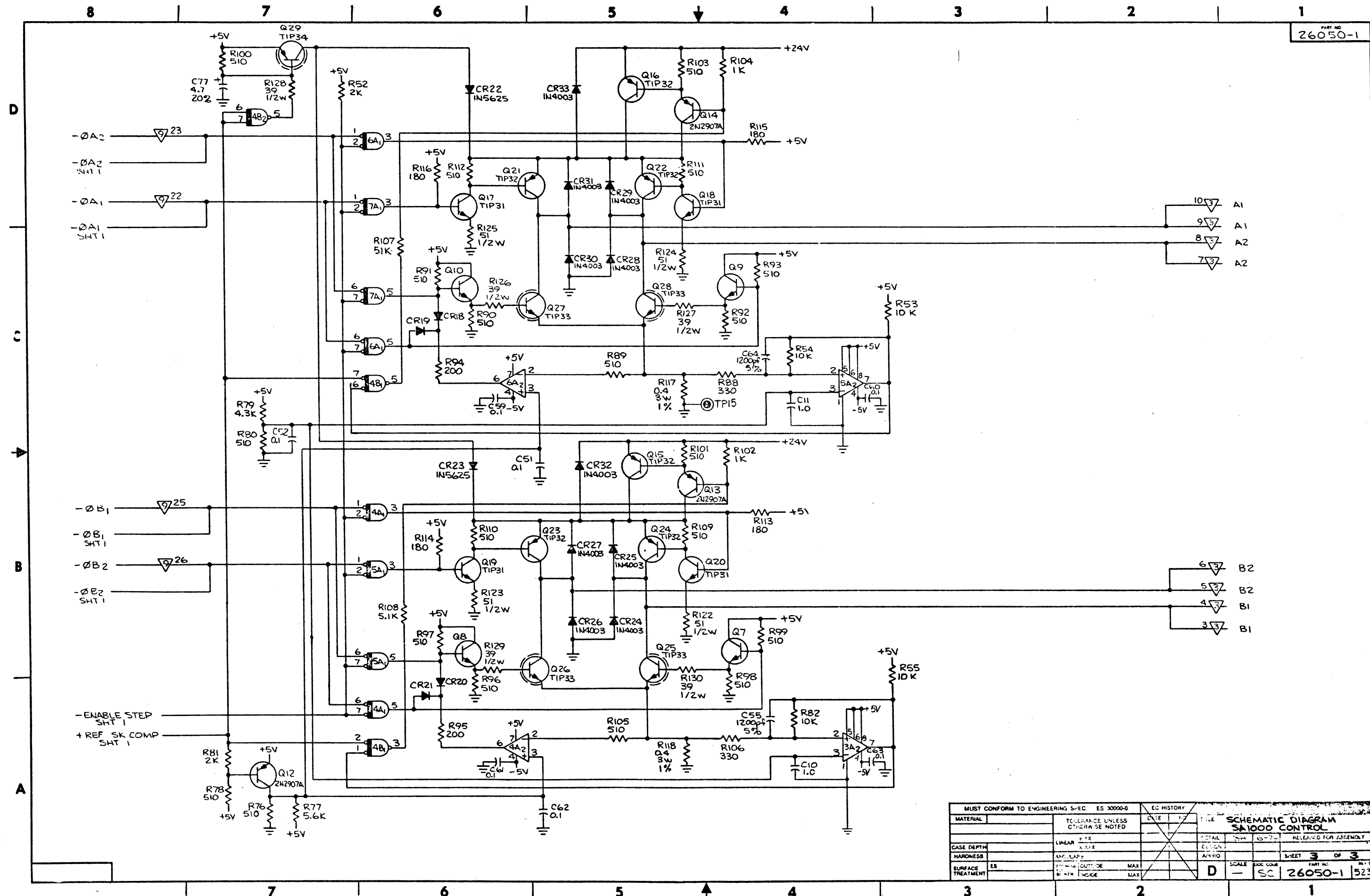

MUST CONFORM TO ENGINEERING SPEC. ES 30000-0		EC HISTORY	
MATERIAL	TOLERANCE UNLESS OTHERWISE NOTED	DATE	BY
CASE DEPTH	LINEAR .5 XX		
HARDNESS	5.5 XX		
SURFACE TREATMENT	ANG. LAP=		
	FINISH OUTSIDE MAX		
	FINISH INSIDE MAX		
TITLE SCHEMATIC DIAGRAM SA1000 CONTROL		SCALE	DOC CODE
RELEASING FOR ASSEMBLY		3	SC
SHEET 3 OF 3		PART NO	REV. TO
		26050-1	5234

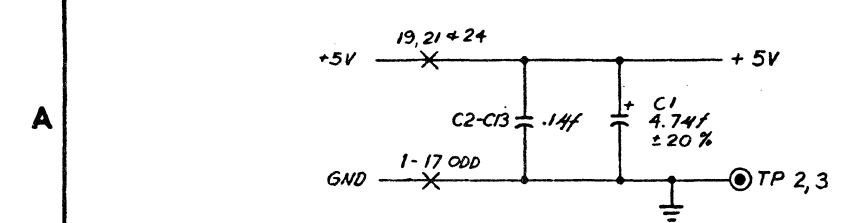
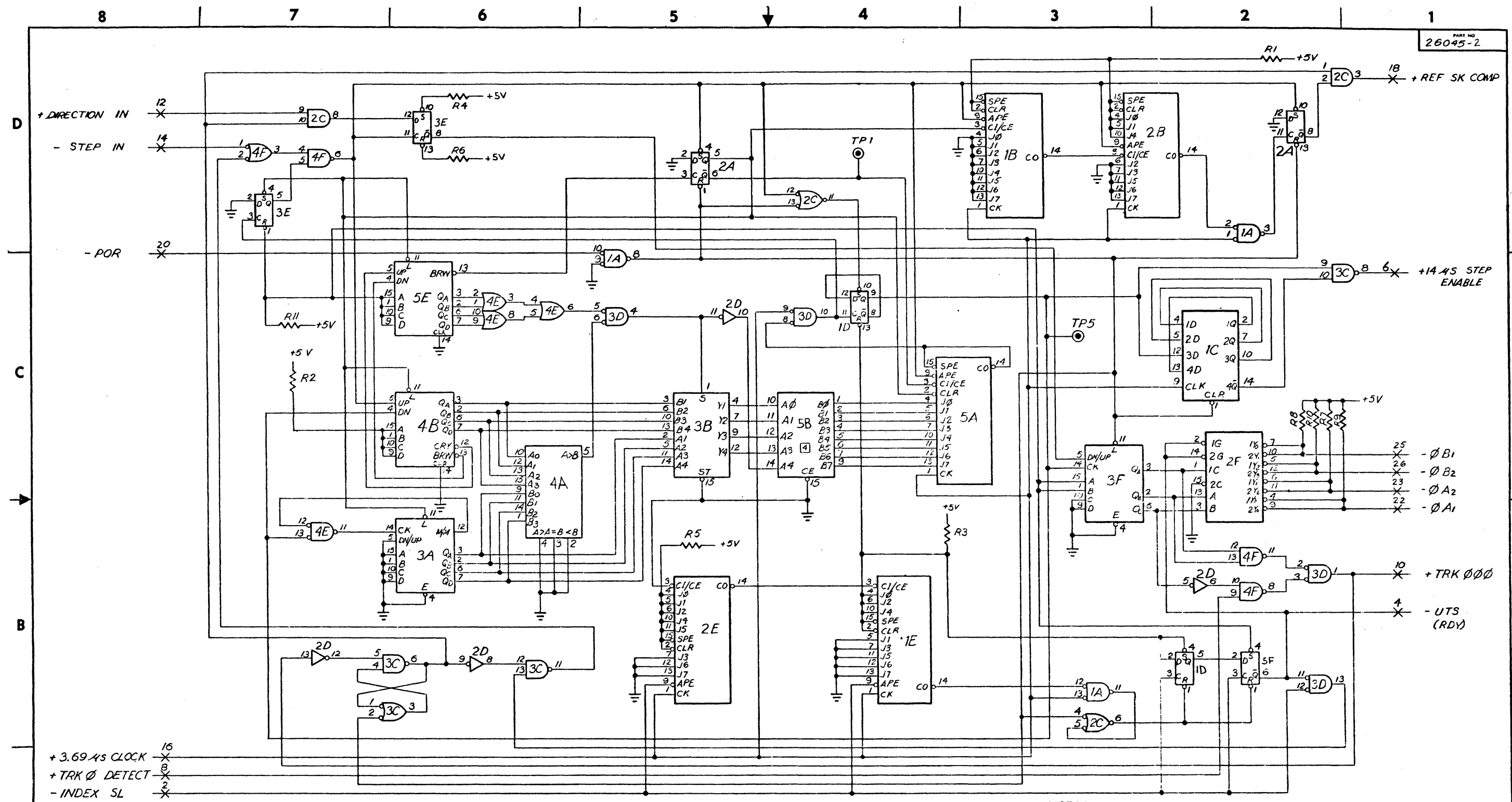

REFERENCE DESIGNATION	
LAST USED	NOT USED
C13	
R11	
TP5	TP4

TYPE	POSITION	UNUSED ELEMENTS	VCC (PIN)	GRD (PIN)
7400	3C 4F		14	7
7402	3D		14	7
7404	2D	2D, 2D ₂	14	7
7409	2C		14	7
7432	1A, 4E	1A ₂	14	7
7474	2A, 1E, 3E, 5E	5E ₂	15	8
7485	4A		15	8
7456	2F		15	8
74157	3B		15	8
74115	1C		15	8
74191	5A, 2F		15	8
74153	4A, 5E		15	8
74153	5A, 1B, 2E, 1E, 2E		15	8
823123	3B		15	8

NOTES:
 UNLESS OTHERWISE SPECIFIED:
 1. ALL RESISTOR VALUES ARE 2K OHMS, 1/4W, 5%.
 2. ALL CAPACITORS ARE AXIAL LEAD, 0.1µF, 50V, +80-20%.
 3. 74 LS SERIES IC'S MAY BE USED.
 [A] IC, PROM, RAMP CNTL.

MUST CONFORM TO ENGINEERING SPEC. ES 30000-0		EC HISTORY		SHUCCART ASSOCIATES	
MATERIAL	TOLERANCE UNLESS OTHERWISE NOTED	DATE	NO.	TITLE	SCHEMATIC DIAGRAM STEPPER LOGIC
CAFE DEPTH	L NEAR - XX E XXX	4-22-74	1A	DETAIL	RELEASED FOR ASSEMBLY
HARDNESS	ANGULAR =			APPRO	SHEET 1 OF 1
SURFACE TREATMENT	CONTOUR OUTSIDE MAX FINISH INSIDE MIN			SCALE	PART NO. 26045-2

DISK CONTROLLER EIGHT INCH SCHEMATICS

REVISIONS			
LTR	DESCRIPTION	DATE	APPROVED
7	PROTOTYPE		
8	REDRAWN & REVISED 1ST RUN	2/3/81	

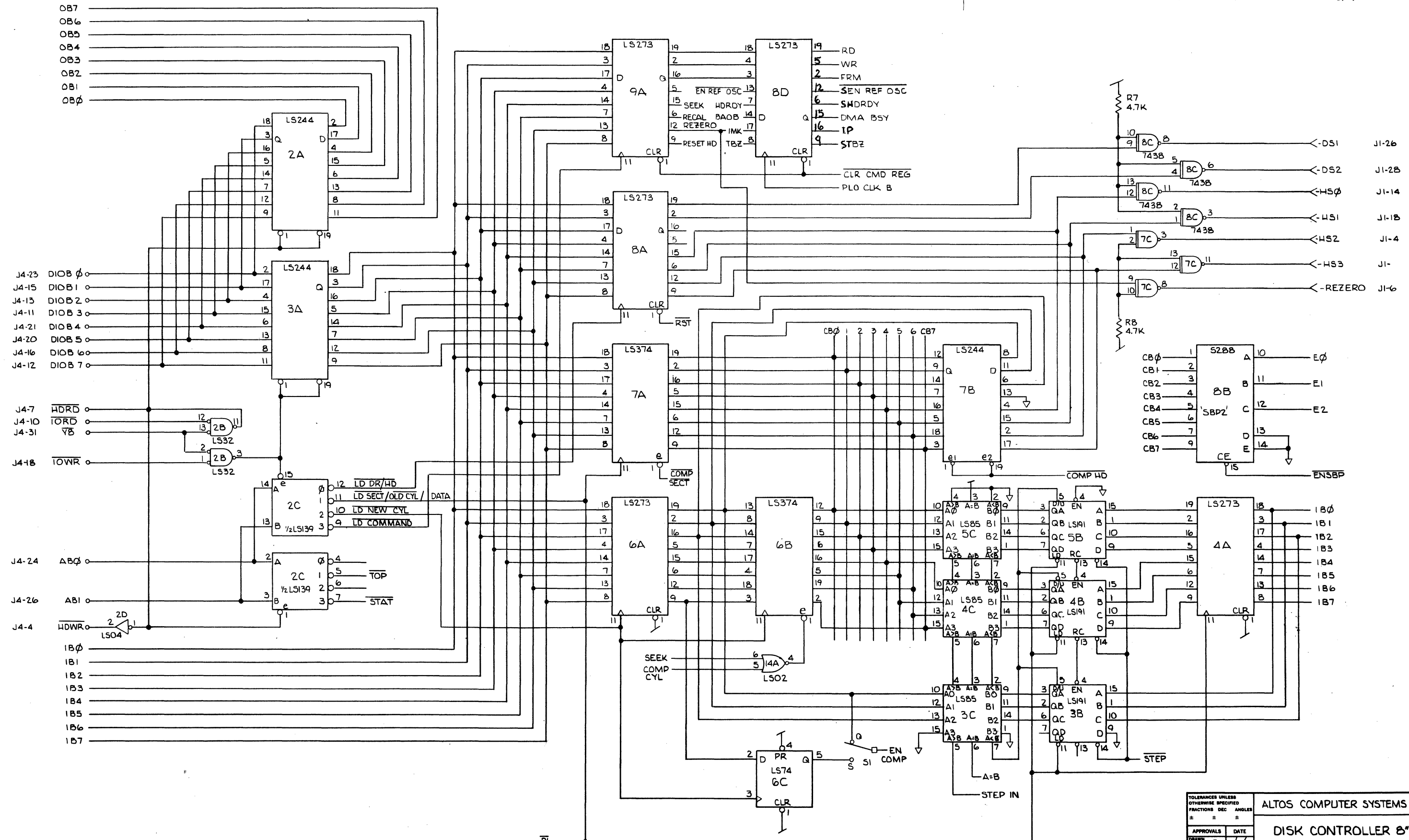

TOLERANCES UNLESS OTHERWISE SPECIFIED		ALLOS COMPUTER SYSTEMS	
FRACTIONS	DEC	DISK CONTROLLER 8"	
ANGLES	±		
APPROVALS	DATE		
DRAWN CR	2/3/81		
CHECKED		SCALE	SIZE D 3500-0021
		DO NOT SCALE DRAWING SHEET 1 OF 5	

REVISIONS			
LTR	DESCRIPTION	DATE	APPROVED

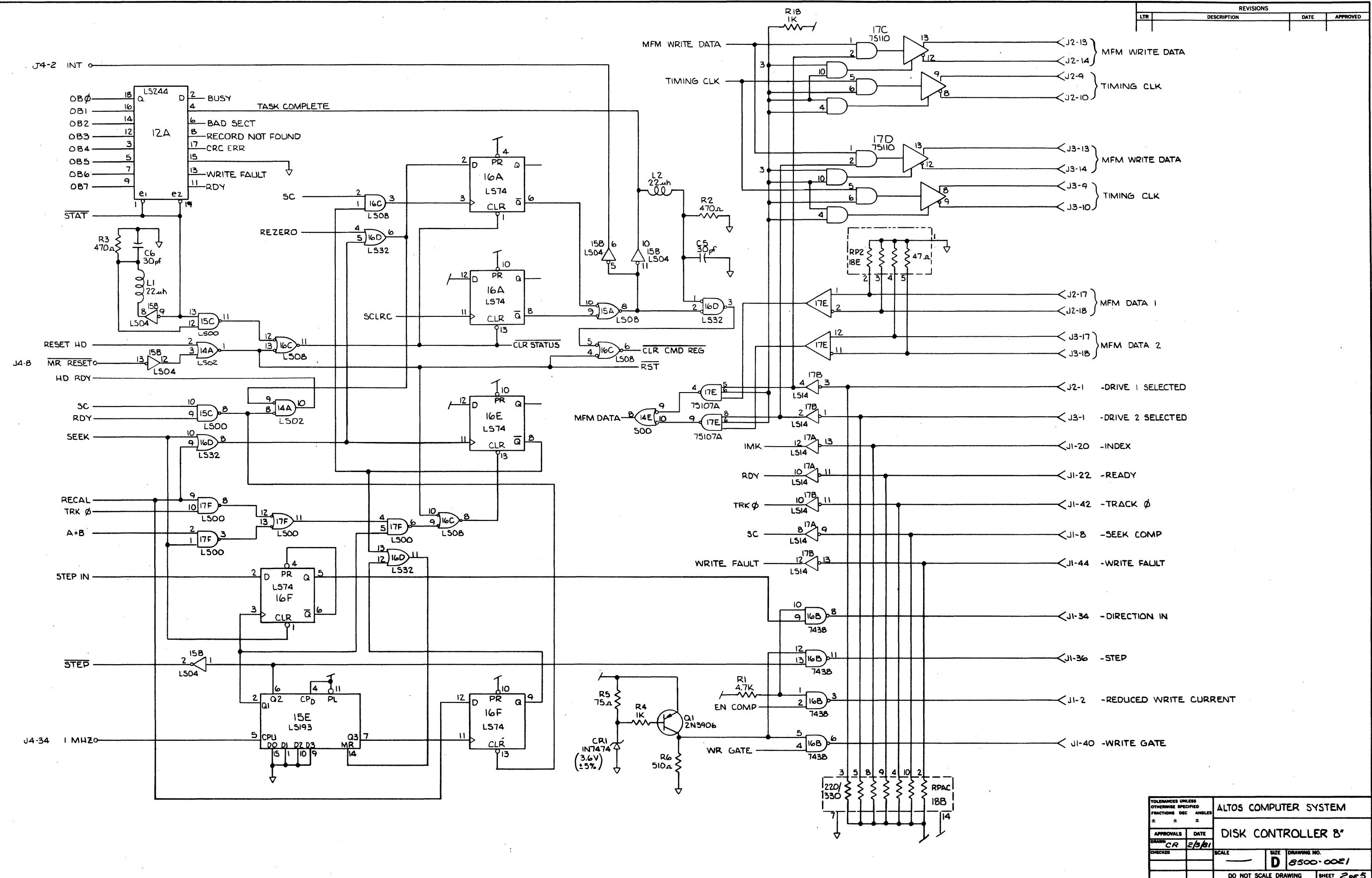

TOLERANCES UNLESS OTHERWISE SPECIFIED		ALTOS COMPUTER SYSTEM	
FRACTIONS DEC ANGLES	± * *	DISK CONTROLLER 8'	
APPROVALS	DATE	SCALE	SIZE DRAWING NO.
DRAWN CR	2/8/81	—	D 8500-0021
CHECKED			DO NOT SCALE DRAWING SHEET 2 of 5

REVISIONS			
LTR	DESCRIPTION	DATE	APPROVED

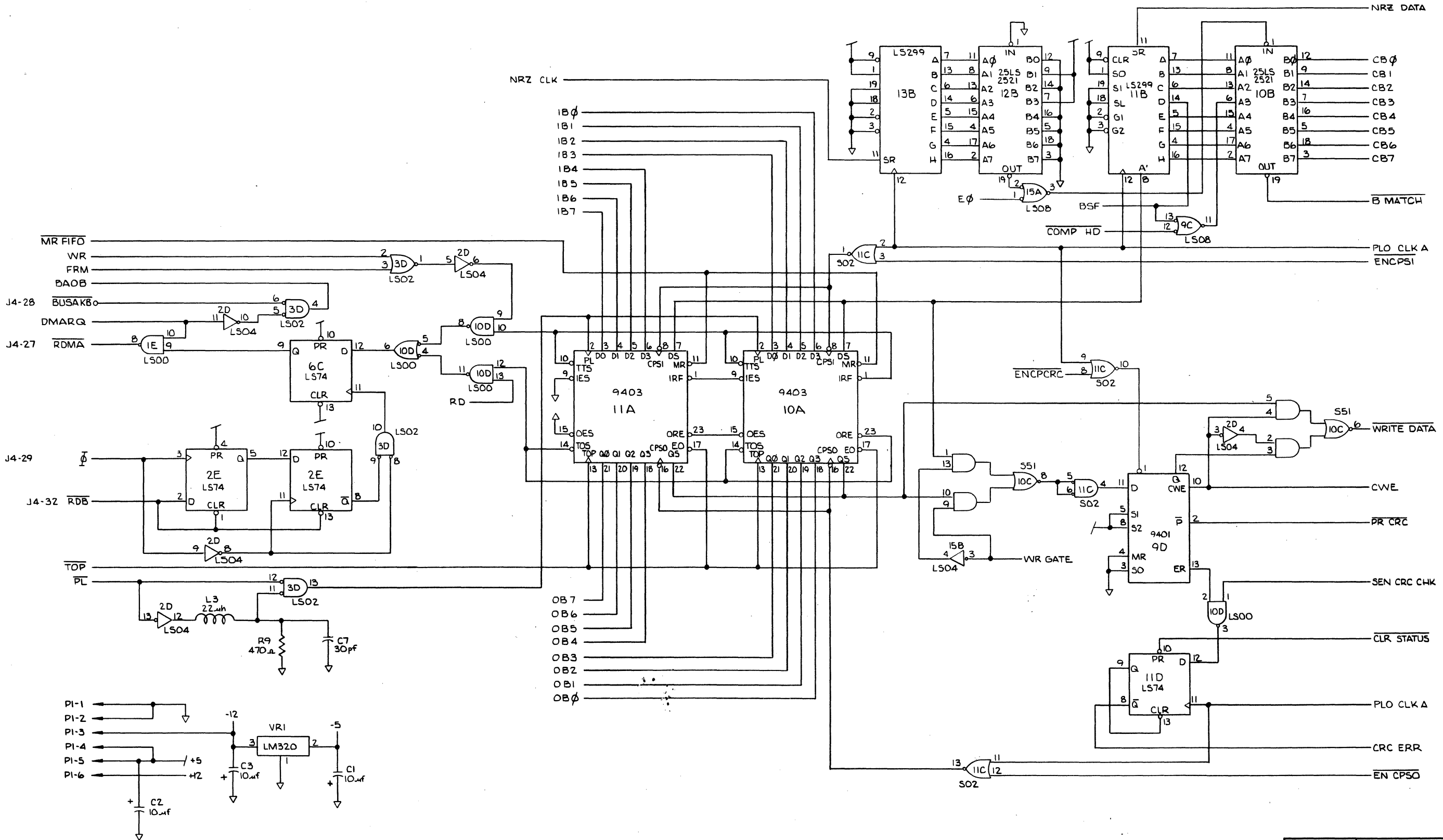

TOLERANCES UNLESS OTHERWISE SPECIFIED		ALLOS COMPUTER SYSTEMS	
FRACTIONS DEC ANGLES	± ± ±	DISK CONTROLLER 8"	
APPROVALS	DATE	SCALE	SIZE DRAWING NO.
DRAWN CR	2/9/81	—	D 8500-0021
CHECKED			DO NOT SCALE DRAWING SHEET 3 OF 5

REVISIONS			
LTR	DESCRIPTION	DATE	APPROVED

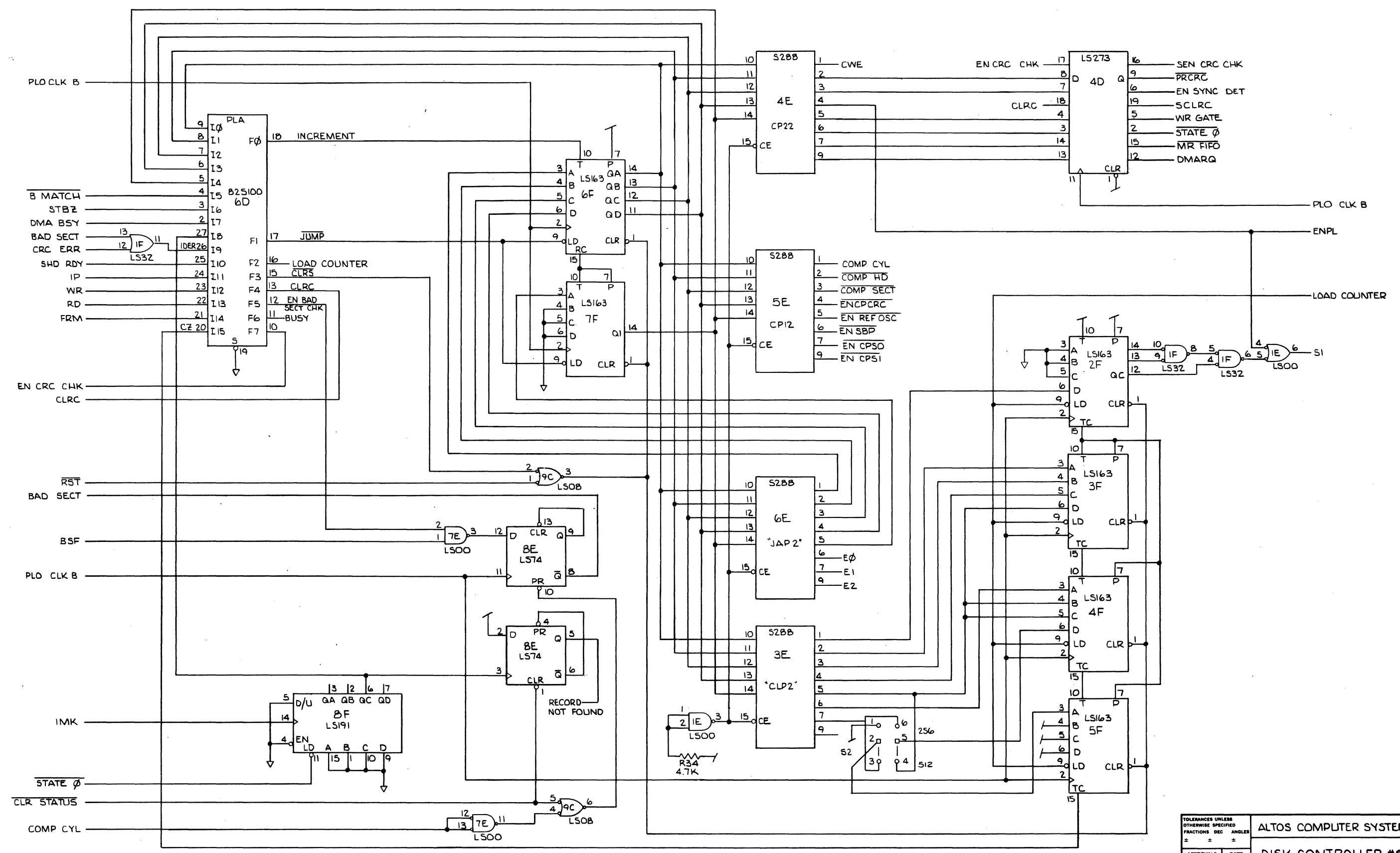

TOLERANCES UNLESS OTHERWISE SPECIFIED		FRACTIONS DEC ANGLES	
±	±	±	±
APPROVALS	DATE	ALLOS COMPUTER SYSTEMS	
DRAWN CR	2/19/81	DISK CONTROLLER #B	
CHECKED	SCALE	SIZE D	DRAWING NO. 8500-0021
			SHEET 4 OF 5

REVISIONS			
LTR	DESCRIPTION	DATE	APPROVED

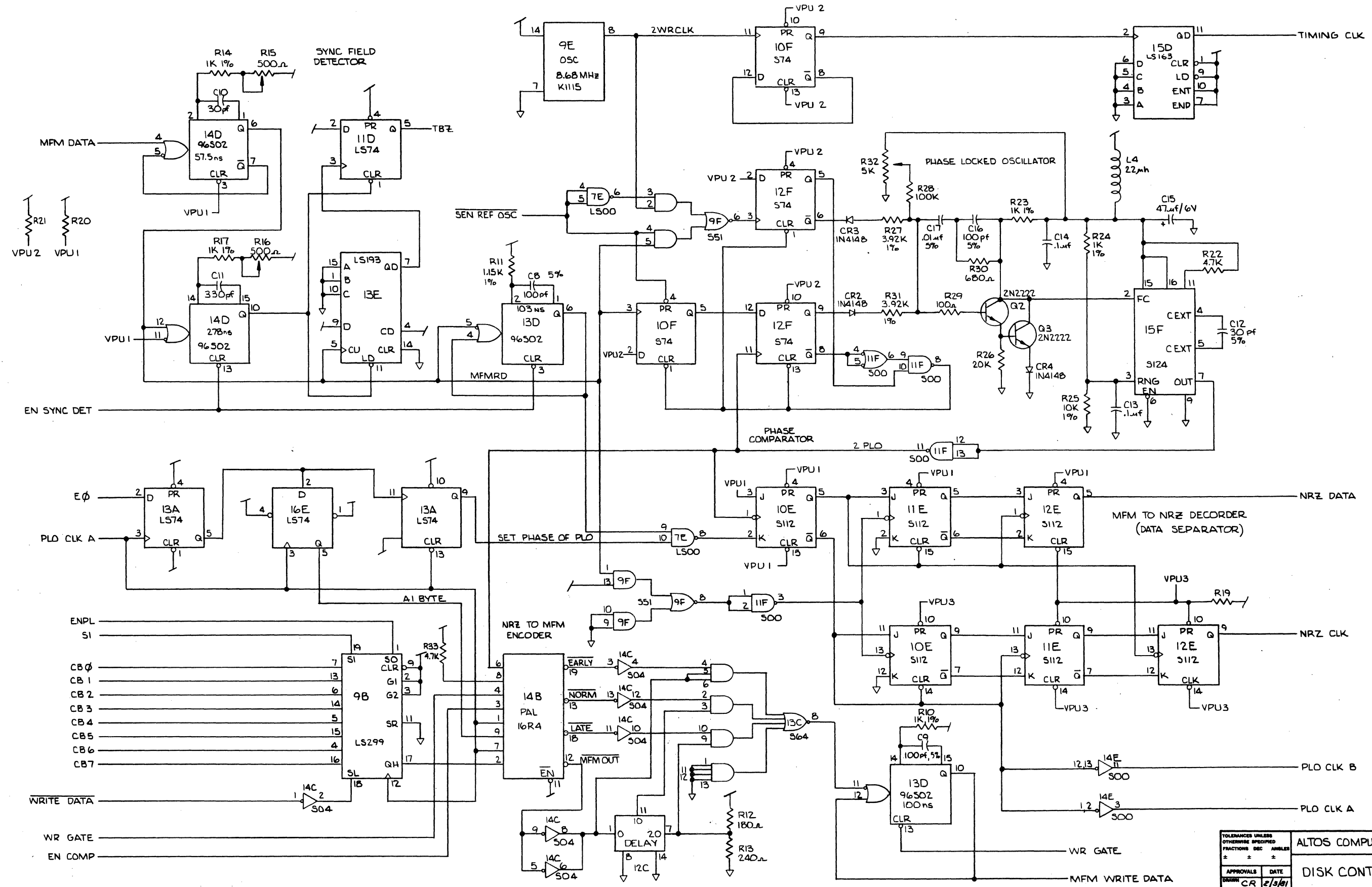

TOLERANCES UNLESS OTHERWISE SPECIFIED		ALLOS COMPUTER SYSTEMS	
±	*	DISK CONTROLLER B	
APPROVALS	DATE	SCALE	SIZE DRAWING NO.
			D 8500-0021
CHECKED			DO NOT SCALE DRAWING
			SHEET 5 OF 5

Altos Computer Systems
World Headquarters
2360 Bering Drive
San Jose, CA 95131
U.S.A.
(408) 946-6700
Telex: 171562 ALTOS SJN