

Electronics[®]

Describing devices to the computer: page 82

Why integrated circuits fail: page 92

Radar for Apollo and beyond: page 115

January 23, 1967

\$1.00

A McGraw-Hill Publication

Below: Transmit-receive switch for
microwave made the monolithic way, page 76

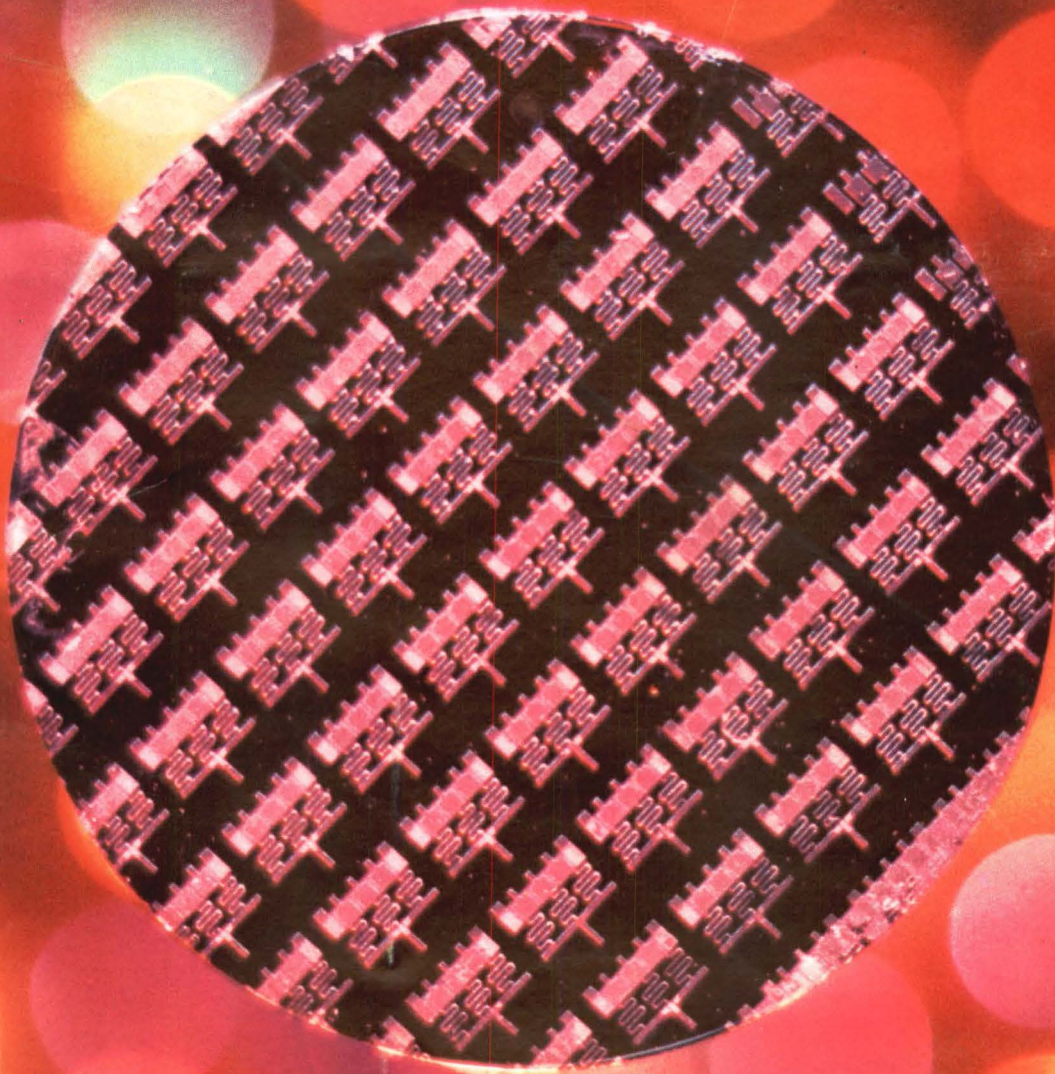

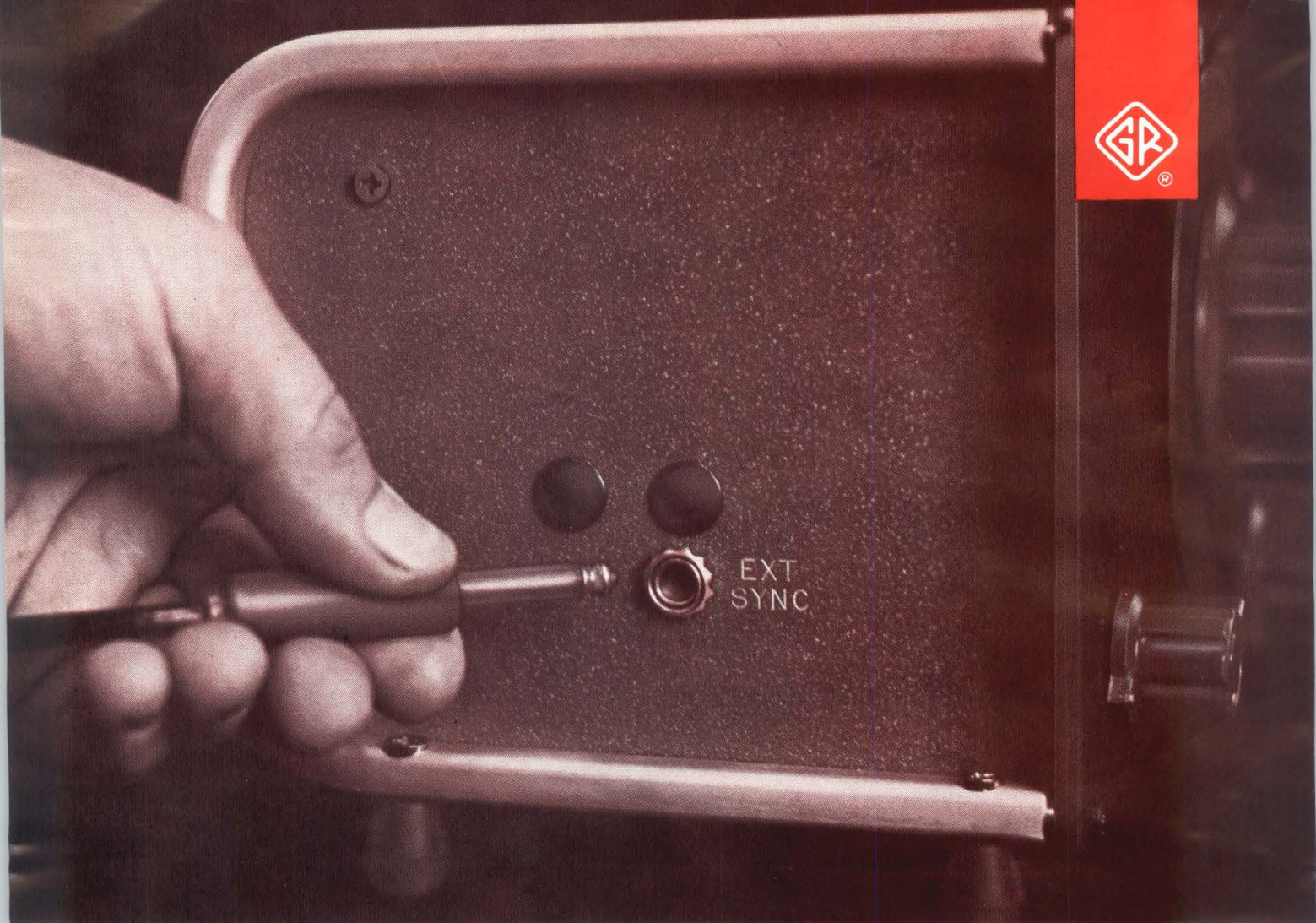

"Sync-able" Oscillators



Type 1309-A . . . \$325 in U.S.A.

- 10 Hz to 100 kHz
- Distortion <0.05%
- Calibrated attenuator



Type 1310-A . . . \$295 in U.S.A.

- 2 Hz to 2 MHz
- Distortion <0.25%
- Constant output



Type 1311-A . . . \$225 in U.S.A.

- 11 fixed frequencies, 50 Hz to 10 kHz
- 1-watt output
- Distortion typically <0.1%

Each of these compact, solid-state oscillators can be phase-locked to an external frequency source. Or, they can furnish synchronizing signals to other instruments. These capabilities permit many applications never before possible with a general-purpose laboratory oscillator. For instance:

Several of these oscillators can be locked to a frequency standard to provide a highly stable signal for each station in a production setup. Thousands of dollars can be saved over current practices.

They can be used as frequency multipliers, since they can lock to a harmonic as well as to the fundamental frequency. Multiplying in this manner is more precise and more convenient than manually setting two different oscillators.

They can serve as high-Q filters. If a small signal (1 volt or less)

with distortion, noise, and hum is applied at the SYNC jack, this signal will appear "cleaned up" and amplified at the oscillator output terminals.

The constant-amplitude signal available at the SYNC jack can be used as a separate output to trigger a counter, scope, or other oscillator.

Other features common to all three of these oscillators are: solid-state circuitry, flat output, low distortion, high accuracy, small size, internal power supply, and low cost. There is no better oscillator value on the market.

For complete information, write General Radio Company, 22 Baker Avenue, W. Concord, Massachusetts 01781; telephone: (617) 369-4400; TWX: 710 347-1051.

GENERAL RADIO

NEW



VERSATILITY

FOR FREQUENCY MEASUREMENTS TO 15 GHz WITH COUNTER ACCURACY

The improved Hewlett-Packard 2590B Microwave Frequency Converter, used with the hp 5245L Counter (with the 5253B or 5252A Plug-in) measures cw frequencies 0.5 Hz to 15 GHz with the accuracy of the counter time base... even on drifting signals. A 12.4-18 GHz range is optional. The 5252A Counter Plug-in with a modification to the counter itself permits direct readout of the frequency.

The 2590B phase-locks an internal transfer oscillator to the signal frequency. When used with the 5245L, accuracy is 5 parts in 10^9 short term, 3 parts in 10^6 /day. Using an external quartz frequency standard for the counter reference provides even higher accuracy.

The 2590B provides pushbutton mode and range selection, front-panel indication of lock, agc to accommodate variations in signal level. The transfer oscillator can be externally modulated for dynamic measurements of signal generator modula-

tion linearity. Direct access to the transfer oscillator and harmonic mixer allow the 2590B to be used as a variable microwave frequency reference, for applications such as wave-meter calibration and frequency marker generation. Yet another way the 2590B can be used is as a 30 MHz receiver with AM and FM demodulating capability.

Here's an instrument that lets you make measurements never before possible... and improves on measurement capabilities previously available. Model 2590B, \$1900. Complete specifications, indicating the versatility of this microwave converter, are available with a call to your Hewlett-Packard field engineer or by writing Hewlett-Packard's Dymec Division, 395 Page Mill Road, Palo Alto, Calif. 94306, Tel. (415) 326-1755, TWX 910-373-1296. Europe: 54 Route des Acacias, Geneva.

Here are some of the advantages offered by the 2590B

- Wide phase-lock range for easy monitoring of drifting signals
- Automatic search oscillator for easy synchronization to the signal
- Continuous observation of jitter, FM and AM on drifting signal, with low-frequency scope
- Accurate FM measurements at deviation rates to 1 MHz, using internal precision FM discriminator
- Measurement of the carrier frequency of pulses as short as 0.5 μ sec
- Sensitivity better than -30 dbm at 0.5 GHz, -10 dbm at 14 GHz

**HEWLETT
PACKARD**  **DYMEC
DIVISION**

DISTORTION ANALYZERS GO SOLID-STATE

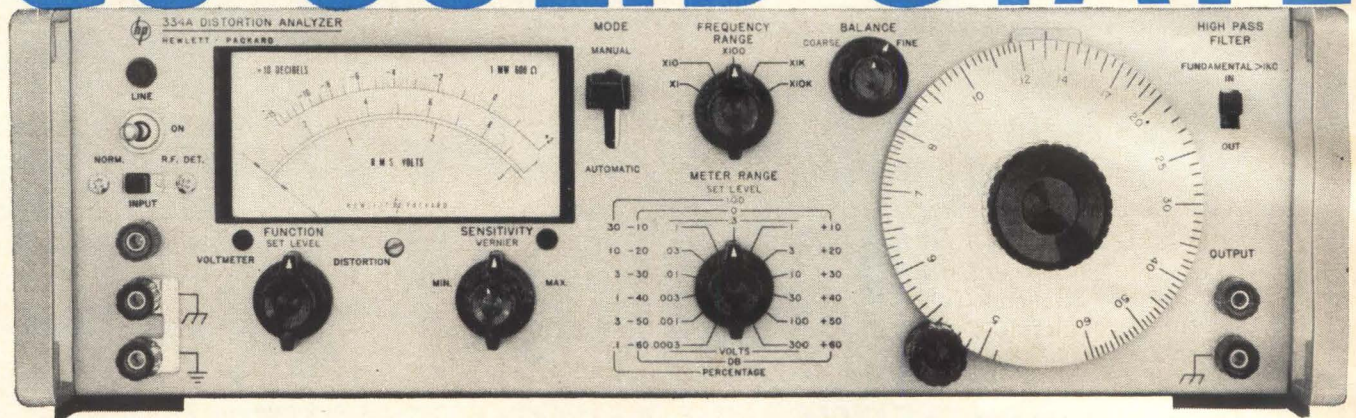

to offer you harmonic distortion measurements 5 cps to 600 kc with 0.1% full-scale distortion sensitivity... plus these features:

"AUTOMATIC NULLING" for simple, fast measurements

0.3 v rms input sensitivity for 100% Set Level reference

300 μ v rms voltmeter full-scale sensitivity (residual noise < 25 μ v)

Solid-state design in four Hewlett-Packard distortion analyzers offers you extended frequency range, greater Set Level sensitivity, improved selectivity, greater overall accuracy, unprecedented ease of use. All four measure total distortion down to 0.1% full scale, 5 cps to 600 kc, with harmonics indicated to 3 mc. They measure voltage 300 μ v to 300 v full scale, have flat frequency response 5 cps to 3 mc. Distortion analyzer and voltmeter input terminals are the same. One-megohm input impedance. Floating input and floating, low-distortion output for scope or true rms voltmeter monitoring.

Two models feature automatic fundamental nulling (>80 db rejection): Manually null to less than 10% of the Set Level reference, flip a switch, and nulling is completed automatically. No more tedious tuning on the more sensitive ranges! Two other models employ high reduction gear drive to aid manual tuning.

Two of the analyzers provide a switchable high-pass filter which attenuates frequencies below 400 cps on signals greater than 1 kc... removes hum and gives you pure distortion measurements.

Two models incorporate an amplitude modulation detector that covers 500 kc to greater than 65 mc, measures distortion at carrier levels as low as 1 v. Options include an indicating meter with VU ballistic characteristics (01) and rear terminals in parallel with front input terminals (02).

Ask your Hewlett-Packard field engineer for a demonstration of the model incorporating features most useful to your application. Or write for technical data on all four models to Hewlett-Packard, Palo Alto, Calif. 94304, Tel. (415) 326-7000; Europe: 54 Route des Acacias, Geneva; Canada: 8270 Mayrand St., Montreal.

Model	Automatic Fundamental Nulling	High-Pass Filter	AM Detector	Gear Reduction Tuning	Price
331A				✓	\$590
332A			✓	✓	\$620
333A	✓	✓			\$760
334A	✓	✓	✓		\$790

Data subject to change without notice. Prices f. o. b. factory.

HEWLETT  PACKARD
An extra measure of quality

News Features

Probing the News

- 137 Troubleshooting in trouble spots
- 142 Price slashes wound semiconductor makers
- 146 Aerospace skills brought down to earth
- 153 Jungle fighters on Chesapeake Bay

Electronics Review

- 37 **Lasers:** CO₂ in the spotlight; High power GaAs
- 38 **Solid state:** Through thick and thin
- 40 **Reliability symposium:** Unsafe at any bias; Pick a 2N number
- 41 **Consumer electronics:** IC's sound better; The electronic touch
- 44 **Avionics:** Put to the test
- 44 **Communications:** Table model
- 44 **Computers:** Teen time; Computer tutor; Second thought
- 48 **Space electronics:** Keeping in touch
- 52 **For the record**

Electronics Abroad

- 233 **Great Britain:** Bulk IC's; In the family; Edgewise entry
- 234 **Japan:** In the groove; Startling stripes
- 236 **West Germany:** The right sort
- 236 **France:** Atomic impetus
- 238 **International:** Satellite forecast
- 239 **Around the world**

Departments

- 4 Readers Comment
- 8 People
- 14 Meetings
- 16 Meetings Preview
- 23 Editorial
- 25 Electronics Newsletter
- 59 Washington Newsletter
- 163 New Products
- 164 New Products Index
- 218 New Books
- 220 Technical Abstracts
- 222 New Literature
- 227 Newsletter from Abroad

Title R registered U.S. Patent Office; © copyright 1967 by McGraw-Hill, Inc. All rights reserved, including the right to reproduce the contents of this publication, in whole or in part.

Technical Articles

I. Design

- Microwave** 76 **Monolithic IC techniques produce first all-silicon X-band switch (cover)**
Diodes integrated with microstrip line on silicon pave the way for microwave IC's
Alfred Ertel, Texas Instruments Incorporated
- Design theory** 82 **Computer-aided design, part 5: Doing a model job**
Setting up active device models for computers is a complex but vital task in the CAD process
Cyrus O. Harbourt, University of Texas
- Circuit design** 88 **Designer's casebook**
 - Polarized light triggers remote control system
 - Differential Schmitt trigger with 200-k input impedance
 - Low voltage supply produces good regulation at low cost

II. Applications

- Integrated electronics** 92 **Integrated circuits in action, part 4: Postmortems prevent future failures**
Failure analysis is an important tool for the IC designer in assuring reliability. It's essential to know the right methods for tracking down the causes of failure.
Seymour Schwartz, NASA Electronic Research Center
- 97 **Instruments for failure analysis**
A four-page gatefold lists equipment used to detect physical, chemical, mechanical and electrical abnormalities in integrated circuits.
- Instrumentation** 108 **Chronometer expands pulses to measure nanosecond intervals**
Literally stretching time resolves fast pulse measurements accurately.
George M. Ettinger, G. & E. Bradley, Ltd.
- Space electronics** 115 **1. Apollo radar views the moon**
Radar systems for the Lunar Module carry a heavy responsibility, serving the multiple complex tasks of rendezvous, landing and orbiting calculations.
- 119 **2. New radar systems will map the planets and rescue astronauts**
Looking beyond Apollo, radar is slated to play a big part in space exploration, space stationkeeping and rescue.
Richard F. Broderick, NASA Manned Spacecraft Center

Electronics

Editor-in-Chief: Lewis H. Young

Associate managing editors

Design: Samuel Weber
Application: George Sideris
News: Kemp Anderson
Copy: Sally Powell

Senior editor

Special projects: Donald Christiansen

Senior associate editors

John F. Mason, Robert Henkel, Joseph Mittleman

Department editors

Avionics: W.J. Evanzia
Communications: Leonard Weller
Computers: Wallace B. Riley
Design theory: Joseph Mittleman
Industrial electronics: Alfred Rosenblatt
Instrumentation: Carl Moskowitz
Military electronics: John Mason
New products: William P. O'Brien
Staff writers: William Olcott, Paul Dickson,
Jan Rahm

Section editors

Electronics abroad: Arthur Erikson
Electronics review: Stanley Zarowin
Probing the news: Eric Aiken

Regional bureaus

Domestic

Boston: Thomas Maguire, manager; Robin Carlson
Los Angeles: William B. Wallace, manager; June Ranill
San Francisco: Walter Barney, manager; Mary Jo Jadin
Washington: Robert W. Henkel, manager; William D. Hickman,
Patricia C. Hoehling, correspondents

Foreign

Bonn: John Gosch
London: Michael Payne
Tokyo: Charles Cohen

Copy editors

David Goller, Albert Tannenbaum, James Chang

Graphic design

Art director: Saul Sussman
Assistant art directors: Ann Mella, Valerie Betz
Production editor: Arthur C. Miller

Editorial secretaries: Marlene Angrist, Claire Benell, Lynn Emery, Lorraine Fabry,
Kay Fontana, Patricia Gardner, Lorraine Longo

McGraw-Hill News Service

Director: John Wilhelm; Atlanta: Fran Ridgway; Chicago: James Rubenstein;
Cleveland: Arthur Zimmerman; Dallas: Marvin Reid;
Detroit: N. Hunter; Houston: Robert E. Lee; Los Angeles: Michael Murphy, Gerald Parkinson
San Francisco: Margaret Drosse!
Seattle: Ray Bloomberg; Washington: Arthur L. Moore, Charles Gardner,
Herbert W. Cheshire, Seth Payne, Warren Burkett

McGraw-Hill World News Service

Bonn: John Johnsrud; London: John Shinn;
Mexico City: Bruce Cross; Milan: Ronald Taggiasco;
Moscow: Howard Rausch; Paris: Peter Kilborn;
Rio de Janeiro: Wes Perry; Tokyo: Marvin Petal

Reprints: Susan Nugent

Publisher: Gordon Jones

Electronics: January 23, 1967, Vol. 40, No. 2

Published every other Monday by McGraw-Hill, Inc. Founder: James H. McGraw 1860-1958.

Printed at 99 North Broadway, Albany, N.Y. 12207; second class postage paid at Albany, N.Y.

Executive, editorial, circulation and advertising addresses: McGraw-Hill Building, 330 W. 42nd Street,
New York, N.Y. 10036. Telephone (212) 971-3333. Teletype TWX N.Y. 212-640-4646. Cable address:
MCGRAWHILL N.Y.

Subscriptions are solicited only from those actively engaged in the field of the publication. Position and
company connection must be indicated on orders. Subscription prices: United States and possessions and
Canada, \$8.00 one year, \$12.00 two years, \$16.00 three years; all other countries, \$25.00 one year.
Single copies: United States and possessions and Canada, \$1.00; all other countries, \$1.75.

Officers of McGraw-Hill Publications: Joseph H. Allen, President; Bayard E. Sawyer, Executive Vice President;
Vice Presidents: J. Elton Tuofig, Operations; John R. Callahan, Editorial; Donald C. McGraw, Jr., Marketing;
John M. Holden, Marketing Services; Huber M. Gemmill, Circulation; Angelo R. Venezi, Production;
Robert M. Wilhelm, Controller.

Officers of the Corporation: Donald C. McGraw, Chairman of the Board; Shelton Fisher, President;
L. Keith Goodrich, Hugh J. Kelly and Robert E. Slaughter, Executive Vice Presidents; John J. Cooke,
Vice President and Secretary; John L. McGraw, Treasurer.

Title ® registered in U.S. Patent Office; © Copyright 1967 by McGraw-Hill, Inc. All rights reserved. The contents
of this publication may not be reproduced either in whole or in part without the consent of copyright owner.

Subscribers: The publisher, upon written request to our New York office from any subscriber,
agrees to refund that part of the subscription price applying to copies not yet mailed.
Please send change of address notices or complaints to Fulfillment Manager; subscription
orders to Circulation Manager, Electronics at address below. Change of address notices
should provide old as well as new address, including postal zip code number. If possible,
attach address label from recent issue. Allow one month for change to become effective.

Postmaster: Please send form 3579 to Fulfillment Manager, Electronics,
P.O. Box 430, Hightstown, New Jersey 08520

Readers Comment

Missing dot

To the Editor:

The circuit used to monitor undervoltage and overvoltage in the Designer's casebook [Dec. 12, p. 106] is wrong. The cathodes of SCR_1 and SCR_2 should be tied to the anode of D_3 . Furthermore, D_2 is not shown and it is assumed to be the IN968D.

Barry A. Bertani
Motorola Semiconductor
Phoenix, Ariz.

▪ Reader Bertani is right. The connection dot between the cathodes of SCR_1 and SCR_2 and diode D_3 is missing.

Lobing technique not new . . .

To the Editor:

In Electronics [Oct. 17, p. 38], you described some of the work that Winston E. Kock initiated at NASA's Electronic Research Center. One item described as new technology was the use of sequential lobing techniques in radio astronomy observations to eliminate the effects of "radiation from the earth."

In 1960, the technique was used with a maser radiometer at the University of Michigan's Radio Astronomy Observatory and the university continues to use the technique successfully. Since that time it has also been used at a number of other observatories as well, most notably by Baars and Metzger at the National Radio Astronomy, Green Bank, W. Va.

In addition to reducing the effects of atmospheric noise, the technique approximately doubles the signal-to-noise ratio of a single observation when a scan of a radio source is made.

Theodore V. Seling
Associate research engineer
Radio Astronomy Observatory
Ann Arbor, Mich.

. . . but there were improvements

To the Editor:

In my brief discussion of the use of sequential lobing techniques employed by Haroulis and Brown at the NASA Electronics Research

RESISTORS FOR PERSPICACIOUS DESIGN ENGINEERS

FILMISTOR® PRECISION METAL-FILM RESISTORS

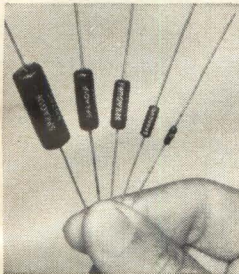

Extended-range Filmistor Resistors now give you dramatic space savings in all wattage ratings — 1/20, 1/10, 1/8, 1/4, 1/2, and 1 watt — with absolutely no sacrifice in stability!

Filmistors offer extended resistance values in size reductions previously unobtainable. For example, you can get a 4.5MΩ resistor in the standard 1/4 watt size, which had conventionally been limited to 1 MΩ. Filmistor Metal-Film Resistors are now the ideal selection for "tight-spot" applications in high-impedance circuits, field-effect transistor circuits, etc.

Other key features are ±1% resistance tolerance, low and controlled temperature coefficients, low inherent noise level, negligible coefficient of resistance, and rugged molded case.

Filmistors surpass the performance requirements of MIL-R-10509E.

Write for Engineering Bulletin 7025C

ACRASIL® PRECISION/POWER WIREWOUND RESISTORS

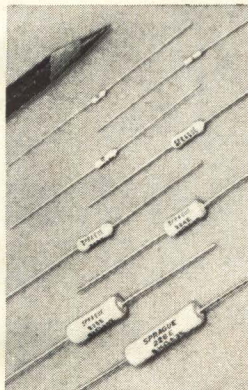

These silicone-encapsulated resistors combine the best features of both precision and power wirewound types, giving them unusual stability and reliability.

Acrasil Resistors are available with tolerances as close as .05%, in power ratings from 1 to 10 watts. Resistance values range from 0.5 ohm to 66,000 ohms.

Their tough silicone coating, with closely matched expansion coefficient, protects against shock, vibration, moisture, and fungus.

Acrasil Resistors meet or exceed the requirements of MIL-R-26C.

Write for Engineering Bulletin 7450

BLUE JACKET® VITREOUS ENAMEL PRECISION/POWER WIREWOUND RESISTORS

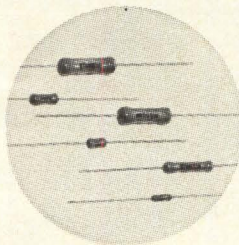

Axial-lead resistors available in ratings from 1 to 11 watts, with resistance tolerances to ±1%. Non-inductive windings available to ±2% tolerance.

All welded end-cap construction securely anchors leads to resistor body. Vitreous coating and ceramic base have closely matched expansion coefficients.

Write for Engineering Bulletins 7410D, 7411A



Tab-terminal Blue Jacket Resistors can be had in a wide selection of ratings from 5 to 218 watts, with several terminal styles to meet specific needs.

Tab-terminal as well as axial-lead Blue Jackets can be furnished to meet the requirements of MIL-R-26C.

Write for Engineering Bulletins 7400B, 7401

KOOLOHM® CERAMIC-SHELL POWER WIREWOUND RESISTORS

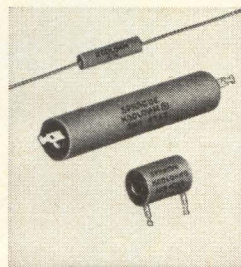

Koolohm Resistors are furnished in axial-lead, axial-tab, and radial-tab styles, in a broad range of ratings from 2 to 120 watts. Both standard and non-inductive windings are available.

Exclusive ceramic-insulated resistance wire permits "short-proof" multilayer windings on a special ceramic center core for higher resistance values. The tough non-porous ceramic shell provides complete moisture protection and electrical insulation. Koolohms can be mounted in direct contact with chassis or "live" components.

Axial-lead Koolohm Resistors to MIL-R-26C are available in MIL styles RW55 and RW56.

Write for Bulletins 7300, 7305, 7310

STACKOHM® POWER WIREWOUND RESISTORS



Sprague Stackohm Resistors are especially designed for equipment which requires power wirewound resistors of minimum height. Their flat silhouette permits stacking of resistor banks in close quarters.

Aluminum thru-bars with integral spacers act as mounting means and also conduct heat from within the resistance element. Resistance windings are welded to end terminations for maximum reliability. An outstanding vitreous coating protects the assembly against mechanical damage and moisture. Ceramic core, end terminations, and vitreous enamel are closely matched for coefficient of expansion.

Stackohm Resistors are available in both 10-watt and 20-watt ratings, and can be furnished with resistance tolerances as close as ±1%. Resistance values range from 1 ohm to 6000 ohms.

Both 10- and 20-watt types meet the stringent requirements of MIL-R-26C.

Write for Engineering Bulletin 7430

Send your request to Technical Literature Service, Sprague Electric Co., 35 Marshall St., North Adams, Mass. 01247, indicating the engineering bulletins in which you are interested.

ON READER-SERVICE
CIRCLE 495

ON READER-SERVICE
CIRCLE 496

ON READER-SERVICE
CIRCLE 497

ON READER-SERVICE
CIRCLE 498

ON READER-SERVICE
CIRCLE 499

SPRAGUE COMPONENTS

RESISTORS
CAPACITORS
TRANSISTORS
THIN-FILM MICROCIRCUITS
INTEGRATED MICROCIRCUITS

PULSE TRANSFORMERS
INTERFERENCE FILTERS
PULSE-FORMING NETWORKS
TOROIDAL INDUCTORS
ELECTRIC WAVE FILTERS

CERAMIC-BASE PRINTED NETWORKS
PACKAGED COMPONENT ASSEMBLIES
BOBBIN and TAPE WOUND MAGNETIC CORES
SILICON RECTIFIER GATE CONTROLS
FUNCTIONAL DIGITAL CIRCUITS

SPRAGUE®
THE MARK OF RELIABILITY

*Sprague and ® are registered trademarks of the Sprague Electric Co.

Introducing... RCA Solid-State GaAs Optical Devices



- Injection Lasers with 1- to 50-W outputs at *room temperature* and threshold currents *below 15A*
- Miniature IR Diode Emitter with focused light output

	TA2628 laser	TA2930 laser	TA7008 IR diode
Peak Power Output (min) @ 27°C	1 W @ 30 A	50 W @ 30 A	0.6 mW @ 0.1 A
Threshold Current	15 A	15 A	100 mA
Output Wavelength	9050 Å ±50	9050 Å ±50	9100 Å ±300
Line Width	5—10 Å	60—100 Å	600 Å ±50
Operating Temp.	-196 to 50°C	-196 to 50°C	-73 to 50°C
Pulse Width/Repetition Rate	0.2 μs/1000 pps	0.2 μs/1000 pps	CW

RCA's wealth of semiconductor experience introduces a new dimension of practicality to solid-state lasers and light diodes. Available now in sampling quantities, each of these optical devices represents an important new tool for the field of electro-optics.

Check these performance benefits of RCA's TA2628 and TA2930* laser diodes:

Practical Power Outputs—conservative peak power rating from 1 to 50 W at room temperature.

Practical Pulse Current—lasing action begins with threshold currents below 15 A.

Practical Circuit Usage—Inexpensive semiconductor pulse circuits can be used without cryogenic hardware.

Practical Size—hermetically sealed in modified TO-5 and TO-46 packages.

RCA's new laser diodes are ready now for your evaluation in applications such as secure communications, intrusion alarms, traffic control, instrumentation, ranging and field illumination.

And RCA's new TA7008 IR emitter is equally exciting. Featuring a miniature but highly efficient parabolic reflection system, this tiny device provides a new source of focused light for applications such as card-reading.

Call your RCA representative today for more information on RCA's new family of developmental optical devices. For data sheets and application note on laser power supplies, write RCA Commercial Engineering, Section IN1-4, Harrison, N. J.

*The availability of the TA2930 laser array is presently limited to qualified defense contractors.

RCA Electronic Components and Devices



The Most Trusted Name in Electronics

Circle 6 on reader service card

Center, it was not possible to dwell upon the particular areas of advancement resulting from this work. These include improvements, through the use of sequential lobing, in: the angle boresighting performance of a radiometric antenna; the position determination measurements, particularly for low-angle refractive measurements; the determination of the spatial distribution of atmospheric inhomogeneities and the measurement of radio star flux density ratios. These will be discussed in forthcoming publications.

Winston E. Kock
Vice President, chief scientist
Bendix Corp.
Detroit

Up front

To the Editor:

If the zip code is so important [Newsletter, Dec. 26, p. 25], why isn't it placed in an important position, instead of being tacked on the end? Why not this:

94002
F.E. Emerson
000 Main Street
Belmont, Calif.

Attn. Mr. Jojo, etc.

F.E. Emerson

Belmont, Calif.

State variable simplified

To the Editor:

Louis dePian's article "Analyzing networks with state variables" [Dec. 26, 1966, p. 63] is slightly misleading because of the inference that the order of a network, in general, is the total number of inductors and capacitors, and that the state variables include all of the inductor currents and capacitor voltages.

The order of a passive network and hence the number of first-order, dynamically independent differential equations required to describe it is equal to the total number of inductors plus capacitors minus the number of capacitance loops and inductance cut-sets. (An inductance cut-set can be identified by locating a node to which only inductors are connected.)

Thus the order of a realistic circuit with numerous reactive parasitic elements might be considerably less than the total number of capacitors and inductors. This point is important because one usually wants to obtain the minimum number of equations to describe a model, especially when setting up a problem for digital computation.

Robert B. Mangold
Pittsburgh

The author replies:

Robert Mangold is indeed correct in his comments. The order of a passive network and hence the number of first-order, dynamically independent differential equations required to describe them are equal to the total number of inductors plus capacitors, minus the number of capacitance loops and inductance cut-sets.

However, in the examples given in the article the number of capacitance loops and inductance cut-sets was equal to zero. This was intentionally done so that the examples would be simple and the theory would not be too complex for the reader to grasp.

Louis dePian
George Washington University
Washington

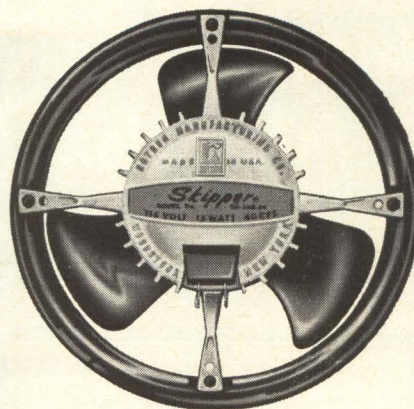

You can buy
the amazing new

Skipper

for less than
\$400 in quantities



■ Time and money saving installation—just cut-out hole for fan and slide neoprene rubber mounting ring over venturi—and the Skipper is instantly secured in position. No mounting holes to drill... no nuts and bolts to handle.

- Complete selection of matching accessories available—line cord and plug, finger guards, etc.
 - Styling and reliability—unmistakably ROTRON.
 - Designed to meet U.L. Approval.
 - Impedance Protected.
 - And it's quiet! Only 39 db SIL.
 - Constructed of unbreakable polymer and die cast aluminum.
 - Built-in heat sink for cool running motor and longer life.
 - For operation at ambient temperatures up to 140°F (60°C).
 - Measures just 5 1/4" in diameter by only 1 3/8" in depth.
 - Just 5/6 lb.—lightweight.
 - Alternate mounting arrangements.
 - Mounts easily anywhere—on any panel thickness (even glass).
 - Available in 115V—60 CPS—1 ø (other ratings available).
- Write, wire or call today for complete details to...

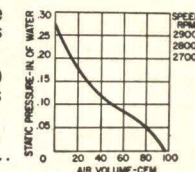

ROTRON MANUFACTURING COMPANY, INC.
WOODSTOCK, NEW YORK Oriole 9-2401
West Coast: Rotron/Pacific, Burbank, Calif.
Canada: Aerovox Canada Ltd., Hamilton, Ont.
© Rotron Europa N.V. Breda, The Netherlands

SUBSCRIPTION SERVICE

Please include an Electronics Magazine address label to insure prompt service whenever you write us about your subscription.

Mail to: Fulfillment Manager
Electronics
P.O. Box 430
Hightstown, N.J. 08520

To subscribe mail this form with your payment and check new subscription renew my present subscription

Subscription rates: in the U.S.: 1 year \$8; two years, \$12; three years, \$16. Subscription rates for foreign countries available on request

CHANGE OF ADDRESS

ATTACH LABEL HERE

If you are moving, please let us know five weeks before changing your address. Place magazine address label here, print your new address below.

name

address

city

state

zip code

Did You Know Sprague Makes 32 Types of Foil Tantalum Capacitors?

125 C TUBULAR TANTALEX® CAPACITORS



- Type 120D polarized plain-foil
- Type 121D non-polarized plain-foil
- Type 122D polarized etched-foil
- Type 123D non-polarized etched-foil

ASK FOR BULLETIN 3602C

Circle 332 on readers
service card

85 C TUBULAR TANTALEX® CAPACITORS



- Type 110D polarized plain-foil
- Type 111D non-polarized plain-foil
- Type 112D polarized etched-foil
- Type 113D non-polarized etched-foil

ASK FOR BULLETIN 3601C

Circle 333 on readers
service card

RECTANGULAR TANTALEX® CAPACITORS



- Type 300D polarized plain-foil
- Type 301D non-polarized plain-foil
- Type 302D polarized etched-foil
- Type 303D non-polarized etched-foil

ASK FOR BULLETIN 3650

Circle 334 on readers
service card

TUBULAR TANTALUM CAPACITORS TO MIL-C-3965C



- CL20, CL21 125 C polarized etched-foil
- CL22, CL23 125 C non-polarized etched-foil
- CL24, CL25 85 C polarized etched-foil
- CL26, CL27 85 C non-polarized etched-foil
- CL30, CL31 125 C polarized plain-foil
- CL32, CL33 125 C non-polarized plain-foil
- CL34, CL35 85 C polarized plain-foil
- CL36, CL37 85 C non-polarized plain-foil

Circle 335 on readers
service card

RECTANGULAR TANTALUM CAPACITORS TO MIL-C-3965C



- CL51 polarized plain-foil
- CL52 non-polarized plain-foil
- CL53 polarized etched-foil
- CL54 non-polarized etched-foil

Circle 336 on readers
service card

For comprehensive engineering bulletins on the capacitor types in which you are interested, write to:

Technical Literature Service
Sprague Electric Company
35 Marshall Street
North Adams, Mass. 01248

48C-5101 R1

SPRAGUE®
THE MARK OF RELIABILITY

Sprague and *®* are registered trademarks of the Sprague Electric Co.

People

It is no secret that the International Business Machines Corp. is pressing to achieve the same position in avionics that it now holds in commercial data processing. Brought in to help the company attain that goal is **L.M. Weeks**, who assumes the position of assistant general manager at IBM's Electronics Systems Center, Owego, N.Y. The center is the avionics arm of the firm's Federal Systems division.



L.M. Weeks

Weeks' new responsibilities include avionics systems, development of the 4 Pi family of airborne and military computers, operations and product assurance. He will also develop IBM's avionics beachhead in the west—designated Avionics Systems-West Coast Operations—just now being established in Los Angeles. The office is being set up principally to provide liaison between IBM and the West Coast's aerospace companies.

The Norden division of the United Aircraft Corp., which is producing custom linear integrated circuits for the Apollo, Minuteman and Poseidon programs, has now decided to produce IC's for the mass market. To lead the way, Norden has hired **Bernard J. Rothlein** as general manager of its newly created solid state department. The 47-year-old Rothlein has a doctorate in physics.

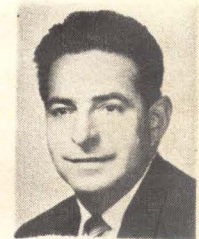

B.J. Rothlein

Signs of expansion appear everywhere at the company's sprawling facility in Norwalk, Conn. About 200 employees from another department have been moved to a different site to make room for the burgeoning solid state department, and more transfers are planned. **Reverse.** In entering the mass market, Norden has reversed the

Reverse. In entering the mass market, Norden has reversed the

Reverse. In entering the mass market, Norden has reversed the



Highest Power Level for RF operation at C-Band: MACHLETT miniature planar triodes

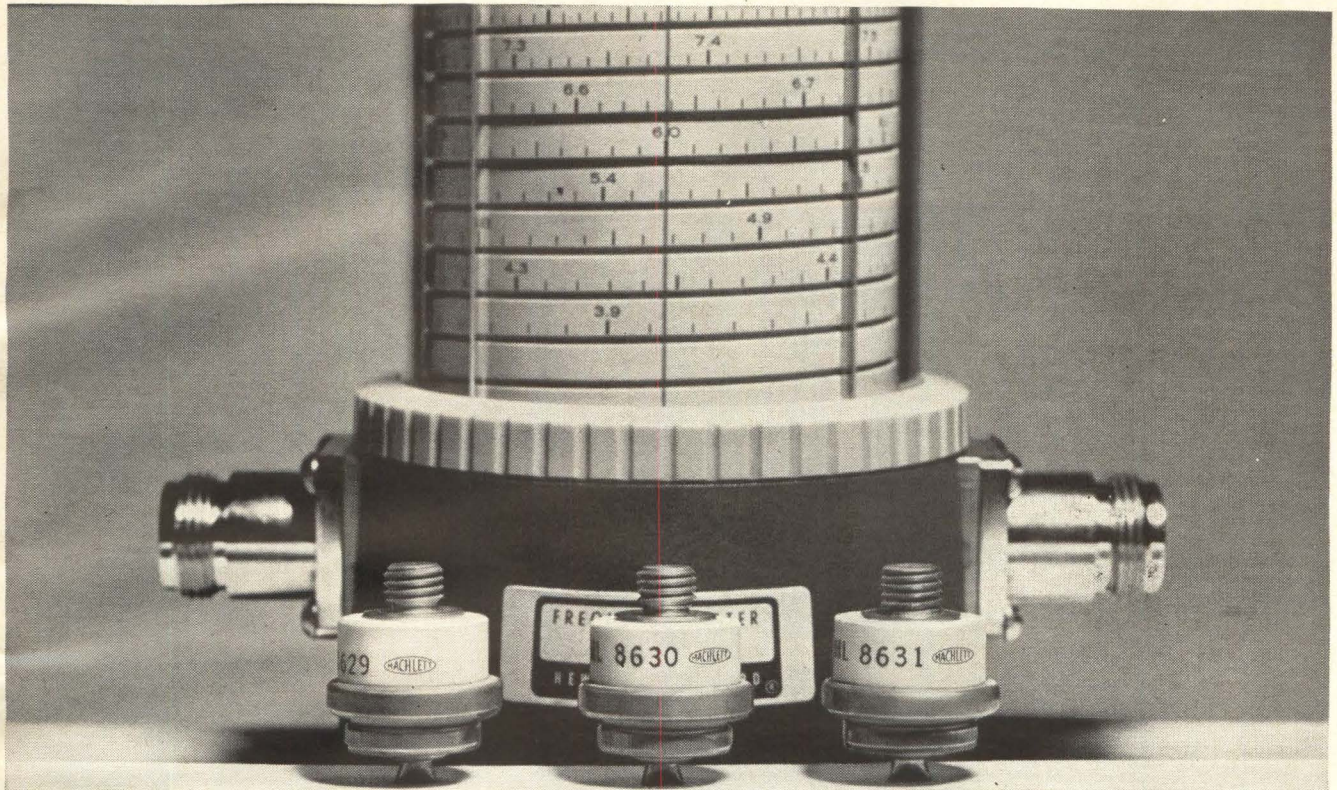

For comparable size and weight in the C-Band region, and higher, the Machlett miniature planar triode provides the highest plate dissipation capability with correspondingly high duty cycle and rf power output. 1 kW grid pulse operation is currently being achieved at 6 Gc with the ML-8630. From cathode rf heater contact to anode rf surface contact, these new tubes ML-8629, ML-8630 and ML-8631 measure only .565 inches high by .7 inch diameter. These "8600 series" tubes will dissipate 100 watts, or more, with suitable cooling devices. Frequency stable for quick on-frequency performance. Phormat cathode for high voltage stability.

For complete details, write
The Machlett Laboratories, Inc.,
Springdale (Stamford), Conn. 06879.

RAYTHEON

THE MACHLETT LABORATORIES, INC.

A SUBSIDIARY OF RAYTHEON COMPANY

How do you get a 1,200-ft. satellite antenna on an itty-bitty spool?



To provide improved radio communications with space satellites, a 1,200-ft. antenna is stored on a tiny reel in the capsule. The antenna itself is a strip of precision-rolled beryllium copper 2" wide by .002" thick. It is heat treated, then uniquely formed to become a self-supporting tube antenna when unreeled.

This precision-rolled, heat-treated strip is supplied by Hamilton Precision Metals—a prime source of rolled or drawn metals made to rigid tolerances in mass production quantities. With its expanded facilities, Hamilton is now producing 7 proprietary metals, 112 commercial alloys and 12 pure metals—in quantity.

Check with Hamilton Precision Metals on your electronic metals requirements for precision strip, foil or wire. Write today for a completely new brochure giving full information about our capabilities as well as detailed properties of over 100 metals.

HAMILTON PRECISION METALS

division of Hamilton Watch Company ■ Lancaster, Pa. 17604

People

usual procedure in which semiconductor companies start out by aiming at the big market before going into custom design. In the custom field Norden has made linear and digital ic's as well as some metal oxide semiconductors. Rothlein says Norden will now produce both standard and custom ic's. He plans extensive use of computer-aided design.

In the 1950's Rothlein organized the Semiconductor division of the Sperry Rand Corp. and handled research, development and manufacturing engineering. In 1959 he left Sperry and set up the National Semiconductor Corp. Shortly thereafter Sperry accused Rothlein and seven other former Sperry employees of pirating trade secrets and won its case in a Federal District Court.

Believers in a high degree of specialization in undergraduate engineering education, a viewpoint neither common nor popular in Britain these days, have a champion in **Emrys Williams**, the new president of Britain's Institution of Electronic and Radio Engineers. Williams, 56, a professor at the University of Wales, has devoted nearly all of his working life to teaching electronics engineering.

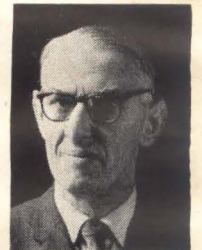

Emrys Williams

In his inaugural speech he attacked the prevalent view that a man will be a better engineer and engineering a better profession if undergraduate courses contain a fair dose of marginal studies like management techniques, languages and world affairs. Williams says that it is the beauty of pure engineering that attracts the young and induces them to go on to study technology.

Insisting that undergraduates study management may dissuade them completely. "Management, like whiskey, is an acquired taste, and neither has much drawing power for the schoolboy."

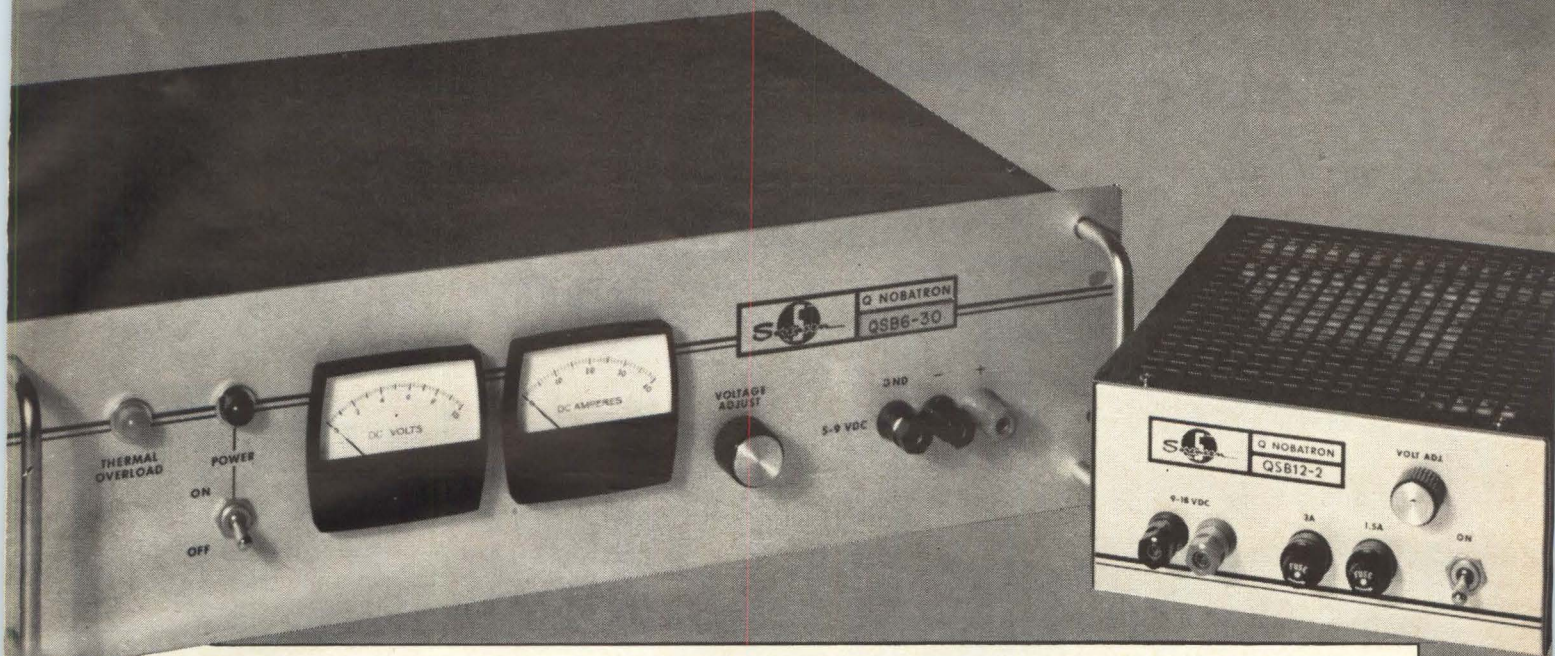

MODEL SELECTION CHART

Voltage	Amps.	Model	Price	Amps.	Model	Price	Amps.	Model	Price	Amps.	Model	Price
5-9	4	QSB 6- 4	\$115	8	QSB 6- 8	\$170	15	QSB 6-15	\$225*	6	QSB 6-30	\$295*
9-18	2	QSB 12- 2	115	4	QSB 12- 4	170	8	QSB 12- 8	225*	15	QSB 12-15	295*
13-26	1.5	QSB 18-1.5	115	3	QSB 18- 3	170	6	QSB 18- 6	225*	12	QSB 18-12	295*
18-36	1	QSB-28- 1	115	2	QSB 28- 2	170	4	QSB 28- 4	225*	8	QSB 28- 8	295*

* For optional voltmeter and ammeter add \$30.

Sorensen OEM/Lab. Power Supply

New Sorensen QSB's give you OEM prices with laboratory performance.

The Sorensen QSB Series, medium range power supplies available in 25, 50, 100 watt models (6, 12, 18 and 28 Vdc nominal) provide laboratory performance in compact bench or rack packages that are ideally suited for budget-type OEM computer, communications and test instrumentation applications. Features such as: precise regulation ($\pm .005\%$ line and load for most models), low ripple (250 μV rms, 1 mV peak to peak), response time (30 μs), all combined with prices starting at \$115. Other features include: inputs

105-125/200-240/210-250 Vac, 47-420Hz; current regulation $\pm .01\%$; temp. range 0-71°C; temp. coefficient .015%/°C; stability .025%/8 hrs.; remote programming and sensing; series/parallel operation. For additional QSB details, or for data on other standard/custom power supplies, AC line regulators or frequency changers, contact your local Sorensen representative, or Raytheon Company, Sorensen Operation, Richards Ave., Norwalk, Connecticut 06856. Telephone: 203-838-6571. TWX 710-468-2940.

RAYTHEON

These solve most of your frequency synthesis problems.

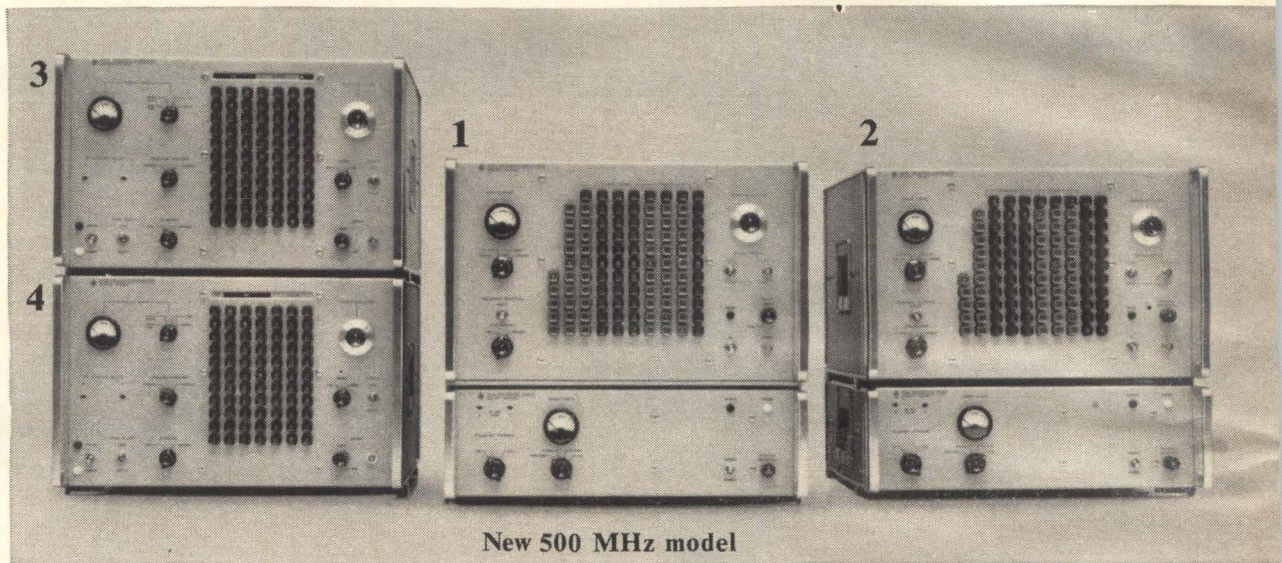

20 μ sec typical frequency switching time

■ increments as small as 0.01 Hz ■ digital push-button and remote frequency selection ■ search oscillator for continuous tuning, sweep capability ■ low spurious signals ■ high stability ■ spectral purity ■ solid-state modular design ■ direct synthesis for best stability, fast switching and fail-safe operation.

1. NEW! A 500 MHz model—the 5105A—100 kHz to 500 MHz in steps as small as 0.1 Hz. Spurious signals 70 dB down. Output: 0 dBm \pm 1 dB. Phase modulation capability: \pm 3 radians max. deviation, DC to 1 MHz rate. Price: 5105A, \$9150.

Requires 5110B Driver (will operate up to four 5105A's), \$4350.

2. 5100A/5110A Synthesizer — 0.01 Hz to 50 MHz in steps as small as 0.01 Hz. Spurious signals 90 dB down. Output 1V rms \pm 1 dB, 100 kHz to 50 MHz; 1 V rms +2 dB, -4 dB, 50 Hz to 100 kHz. A dc to 100 kHz output (15 mV) is also supplied. Price: 5100A, \$8150.

Requires 5110A Driver (will operate up to four 5100A's), \$4350.

3. 5102A Synthesizer — Dual-range 0.01 Hz to 100 kHz with increments as small as 0.01 Hz, and

0.1 Hz to 1 MHz with increments as small as 0.1 Hz. Spurious signals 90 dB down (70 dB down in 1 MHz range). Adjustable output 300 mV to 1 V rms (80 mV < 50 Hz); auxiliary outputs include a (dc to 1 MHz) + (30 MHz) signal. Price: \$6500.

4. 5103A Synthesizer—Dual-range, 0.01 Hz to 1 MHz, increments as small as 0.1 Hz; and 0.1 Hz to 10 MHz, increments small as 1 Hz. Spurious signals 70 dB down (50 dB down in 10 MHz range). Output adjustable from 300 mV to 1 V rms (20 mV < 50 Hz); auxiliary outputs include a (dc to 1 MHz) + (30 MHz) signal. Price: \$7100.

Also available: **The 10514A Double-Balanced Mixer**, extracts the sum or difference of two input frequencies with low noise, high efficiency, low intermodulation; input 200 kHz to 500 MHz, output dc to 500 MHz. Price \$180 (less in quantity).

The 10515A Frequency Doubler, extends the usable frequency range of synthesizers or other signal sources; input 500 kHz to 500 MHz, output 1 MHz to 1 GHz. Price \$120.

The 10511A Spectrum Generator, generates a train of 1 nsec pulses when driven by a sine wave; produces harmonics into the 1 GHz region. Price \$150.

They solve the rest.



If a Hewlett-Packard standard model frequency synthesizer won't handle your requirements, don't worry. Our team of highly experienced synthesizer engineers can consult with you and build a special synthesizer if it's feasible. Frequency synthesizer design is their full-time job, not a sideline.

In most applications, though, you'll find that you can meet your "special" requirements with high-performance HP standard synthesizers. They're especially useful for their fast switching, and give you a remarkably broad source of spectrally pure, stable frequencies. Signals are derived from a stable

internal frequency standard, (aging rate $< \pm 3 \times 10^{-9}$ /24 hours), or you can use an external 1 or 5 MHz standard. The instruments use a direct synthesizing technique (arithmetic operations instead of phase-locked oscillators) to preserve frequency standard stability and provide fast frequency selection and fail-safe operation. But if you do need a special, remember that we've got the specialists.

For more information, call your HP field engineer or write Hewlett-Packard, Palo Alto, California 94304, Tel. (415) 326-7000; Europe: 54 Route des Acacias, Geneva.

HEWLETT  PACKARD
An extra measure of quality

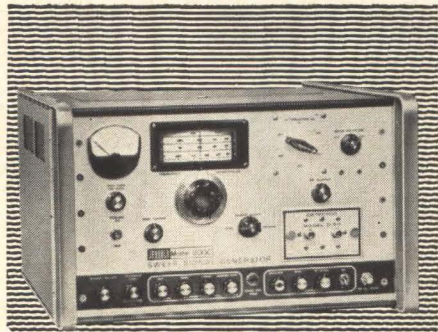

Jerrold's new Model 900-C is the most conceited sweep signal generator on the market!

We get a little embarrassed. The many thousands of Model 900's now in the field have built up such a tremendous reputation for dependability and service that they're beginning to act smug. They "show off" with gut features like built-in oscilloscope pre-amp, four mode operation and continuously variable sweep widths from 10 kHz to 400 MHz (center frequencies from 500 kHz to 1200 MHz)—just to name a few.

But that's not the worst of it.

The New 900-C really gets overbearing when it starts performing. Say you want to observe the entire frequency range of a unit under test: ... or examine a narrow 10 kHz beamwidth ... or make a quantitative analysis of the response of a wide range of electronic devices such as receivers, amplifiers, filters, transformers, or transmission lines.

It does these chores so easily, so accurately, and so efficiently, we despair of ever deflating its ego.

One small revenge. Our New Model 900-C literature is very, very modest. Send for a copy.

JERROLD MEASUREMENT AND
TEST INSTRUMENTATION

JERROLD ELECTRONICS CORPORATION
Government and Industrial Division
Philadelphia, Pa. 19105

Meetings

Ultrasonic Manufacturers Association Technical Symposium and Meeting, Ultrasonic Manufacturers Association; New York, Jan. 25.

Conference on Color Television Broadcasting, Society of Motion Picture and Television Engineers; Park Shelton Hotel, Detroit, Jan. 27-28.

Power Meeting, IEEE; Statler Hilton Hotel, New York, Jan. 29-Feb. 3.

Forum on Electromagnetics and Antennas, Electrical Engineering Department at the University of Illinois, Urbana, Ill., Jan. 30-Feb. 3.*

Symposium on Nondestructive Testing of Welds, Illinois Institute of Technology Research Institute; Illinois Institute of Technology, Chicago, Jan. 30-Feb. 2.

American Society for Testing and Materials Meeting, American Society for Testing and Materials; Statler Hilton Hotel, Detroit, Mich., Feb. 5-10.

Winter Convention on Aerospace & Electronic Systems, IEEE; International Hotel, Los Angeles, Feb. 7-9.

Electronic Packaging Conference, Society of Automotive Engineers; Roosevelt Hotel, New York, Feb. 14-16.

International Solid State Circuits Conference, IEEE; University of Pennsylvania, Sheraton Hotel, Philadelphia, Feb. 15-17.

Airborne Photo-Optical Instrumentation Seminar, Society of Photo-Optical Instrumentation Engineers; Ramada Inn, Cocoa Beach, Fla., Feb. 20-21.

National Air Meeting on Collision Avoidance, Institute of Navigation; Dayton, Ohio, Feb. 23-24.*

Numerical Control Society Conference, Statler Hilton Hotel, Detroit, March 1-3.

Particle Accelerator Conference—Accelerator Engineering and Technology, IEEE; Shoreham Hotel, Washington, March 1-3.

International Symposium on Residual Gases in Electron Tubes and Sorption-Desorption Phenomena in High Vacuum, Italian Society of Physics; Rome, March 14-17.

Temperature Measurements Society Conference and Exhibit, Temperature Measurements Society; Hawthorne Memorial Center, Los Angeles, March 14-15.

International Convention, IEEE; New York Hilton Hotel and Coliseum, March 20-24.

Symposium on Modern Optics, Polytechnic Institute of Brooklyn; Waldorf-Astoria Hotel, New York, March 22-24.

Photovoltaic Specialists Conference, IEEE; Sheraton Cape Colony Inn, Cocoa Beach, Fla., March 28-30.

Symposium on Microwave Power, International Microwave Power Institute; Stanford University, Stanford, Calif., March 29-31.

Business Aircraft Conference and Engineering Display, Society of Automotive Engineers; Broadview Hotel, Wichita, Kan., April 5-7.

International Electronic Components Show, FNIE; Porte de Versailles, Paris, April 5-10.

Technical Meeting and Equipment Exposition, Institute of Environmental Sciences; Washington, April 10-12.

Call for papers

Meeting of the Anti-Missile Research Advisory Council, Advanced Research Projects Agency; Arlington, Va., April 17-19. Feb. 15 is deadline for submission of papers to Joshua Menkes, chairman, Institute for Defense Analysis, 400 Army-Navy Drive, Arlington, Va. 22202

Association for Computing Machinery Conference, Association for Computing Machinery; Sheraton Park Hotel, Washington, Aug. 29-31. Feb. 20 is deadline for submission of abstracts to Jack Minker, program manager, Auerbach Corp., 1815 N. Fort Meyer Drive, Arlington, Va. 22209

Conference on Laser Engineering and Applications, IEEE; Washington Hilton Hotel, Washington, June 6-9. Feb. 20 is deadline for submission of abstracts to L.K. Anderson, Bell Telephone Laboratories, Murray Hill, N.J. 07971

* Meeting preview on page 16

This is the solid state 0.003% voltage calibrator with variable current limiting and overvoltage trip. □ Line and load regulation, 0.0005% of setting. □ Panel meter monitors either output voltage or current. □ No cooling fan is needed, so you can forget about damage from dirt and dust. □ All circuits are shielded and guarded. □ Resolution is 0.1 ppm. □ Only 7 inches high. □ Weighs 40 lbs. □ Price is \$2490. □ For more information on the Fluke 332A Voltage Calibrator, call your full service Fluke sales engineer (listed in EEM) or write directly to the factory.



In a crowd or all alone, the Fluke 332A DC Voltage Calibrator stands out. There isn't another calibrator on the market at any price that offers all the advanced technical and user features. By any measure, it's the leader!



Fluke • Box 7428, Seattle, Washington 98133 • Phone: (206) 774-2211 • TWX: (910) 449-2850

In Europe, address Fluke International Corporation • Suite D, Ambassador Hotel, Sophialaan 2, The Hague, The Netherlands

Circle 15 on reader service card

New from Sprague!

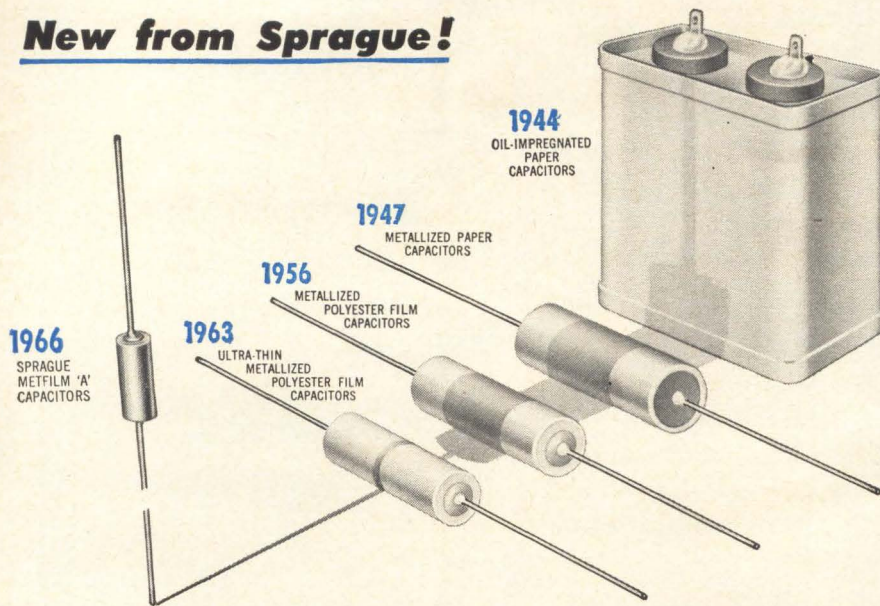

METFILM* 'A' CAPACITORS ... dramatically smaller in size, yet more reliable than military-grade capacitors of the past!

Just a few years ago, the only 10 μ F capacitor considered dependable enough for military applications was Type CP70 (to JAN-C-25), and was a block-busting 3 $\frac{3}{4}$ " wide x 1 $\frac{3}{4}$ " thick x 4" high. Today, you can get a military-quality 10 μ F tubular capacitor measuring only $\frac{1}{2}$ " in diameter x 1 $\frac{1}{4}$ " long. And it's more reliable than any capacitor of the past!

Sprague Type 680P Metfilm 'A' Metallized Capacitors meet all environmental requirements of MIL-C-18312, yet they occupy only one third the volume of conventional metallized film capacitors of equivalent capacitance and voltage rating. Employing a new thin organic film dielectric system, Type 680P capacitors use a dual film totalling only 0.00008" thick, as compared to conventional polyester-film capacitors with a single film measuring 0.00015".

Another distinct advantage of the Metfilm 'A' dielectric system is minimum degradation of electrical properties during life.

Hermetically sealed in corrosion-resistant metal cases, capacitor sections are effectively of non-inductive construction, resulting in capacitors with performance characteristics superior to those of comparably-sized capacitors.

Type 680P Metfilm 'A' Capacitors are available with capacitance values to 10 μ F in both 50 and 100 volt ratings.



For complete technical data, write for Engineering Bulletin 2650 to Technical Literature Service, Sprague Electric Company, 35 Marshall Street, North Adams, Massachusetts 01247.

*Trademark

SPRAGUE COMPONENTS

CAPACITORS	PACKAGED COMPONENT ASSEMBLIES
TRANSISTORS	FUNCTIONAL DIGITAL CIRCUITS
RESISTORS	MAGNETIC COMPONENTS
THIN-FILM MICROCIRCUITS	PULSE TRANSFORMERS
INTEGRATED CIRCUITS	CERAMIC-BASE PRINTED NETWORKS
INTERFERENCE FILTERS	PULSE-FORMING NETWORKS



*Sprague and  are registered trademarks of the Sprague Electric Co.

Meeting preview

Avionics and antennas

Until now the contest for the design of a single collision avoidance system for United States airlines has been conducted behind closed doors [Electronics, Jan. 9, p. 46]. In Dayton, on Feb. 23 and 24, details of the competition will be aired, when avionics firms describe their differing, and incompatible, systems at the Institute of Navigation's National Air Meeting on Collision Avoidance.

Engineers for each of the major competitors—TRG Inc., the National Co., Collins Radio Co. and the McDonnell Co.—will explain their systems, list the assets of each technique and presumably defend their systems during floor debate.

Collins, McDonnell and TRG use time-frequency designs, with Collins dependent on accurate atomic clocks, McDonnell on ground stations and TRG on less accurate clocks. National proposes a proximity warning system.

A Forum on Electromagnetics and Antennas at the University of Illinois in Urbana, Jan. 30 to Feb. 3, will combine a two-day review of fundamentals with a three-day course in advanced theories and their applications.

Paul E. Mayes, forum director, will describe the design of new log periodic antennas with gains and radiation characteristics previously considered unattainable. Raymond Duhamel, manager of the electromagnetic laboratory at the Hughes Aircraft Co., will discuss microwave components that can produce bandwidths as great as 20-to-1. And Louis J. Cutrona, vice president of the Conduction Corp., will speak on optical processing.

Other sessions will cover large antennas for communications and radio astronomy, numerical solutions to antenna problems, radio location systems, impedance of antennas in ionized media, propagation, polarization, noise, lasers, coherence and scattering.

The fees, ranging from \$150 to \$250, depend on the number of sessions attended.

First come first served.

You can have all the SDS T Series integrated circuit modules you want now. We're in full production.

All T Series active elements are integrated circuits and guarantee reliable operation at clock rates to 10 mc. Each circuit output drives 14 unit loads, even after generous allowances for wiring capacitance.

Outputs switch 60 ma (4 times more than standard IC's). Noise rejection is at least 1.5 volts at the 0 and 4-volt logic levels.

SDS Natural Logic gives you AND and OR as well as NAND and NOR —

Each card uniquely keyed for proper installation.

Test points.

Ground plane laminated through middle of entire glass-epoxy board.

Load resistors separate from IC's for heat isolation.

Discrete diode-resistor inputs for gating flexibility, high noise rejection.

Four pins reserved for ground lines.

Four integrated-circuit buffer amplifiers in each hermetically sealed TO-5 can.

52 ribbon connectors (26 each side) for easy access to all circuits.

All components clearly identified.

Individual power line filters.

Actual size 4¼ x 4¾.

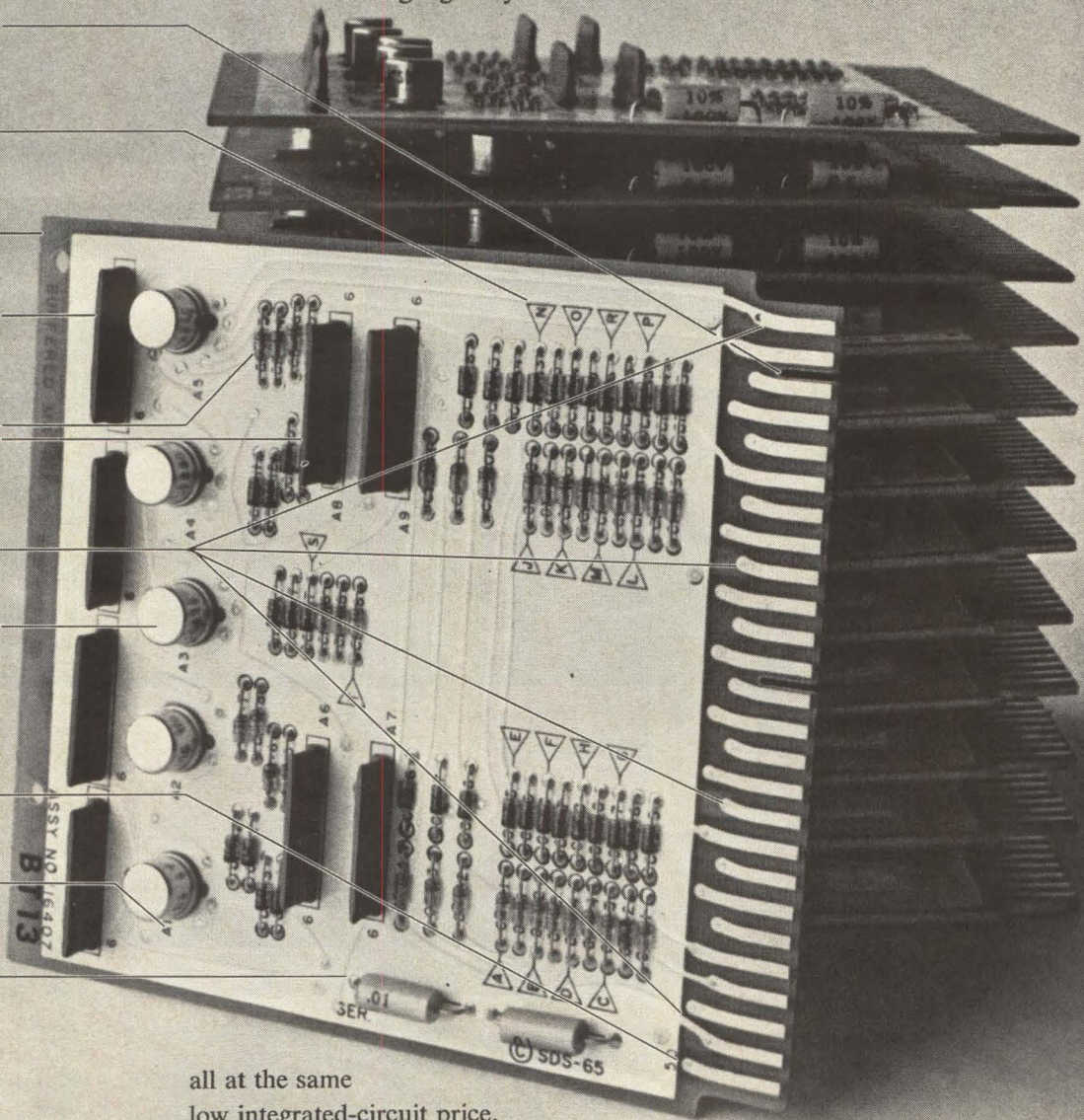

all at the same low integrated-circuit price.

We designed these modules for our new Sigma computers, but we also intend to become the largest manufacturer of logic modules for system designers.

We don't want to give away any of our Sigma secrets. But we'll sell them pretty cheap.

SDS

Scientific Data Systems,
Santa Monica, California

As simple as this:

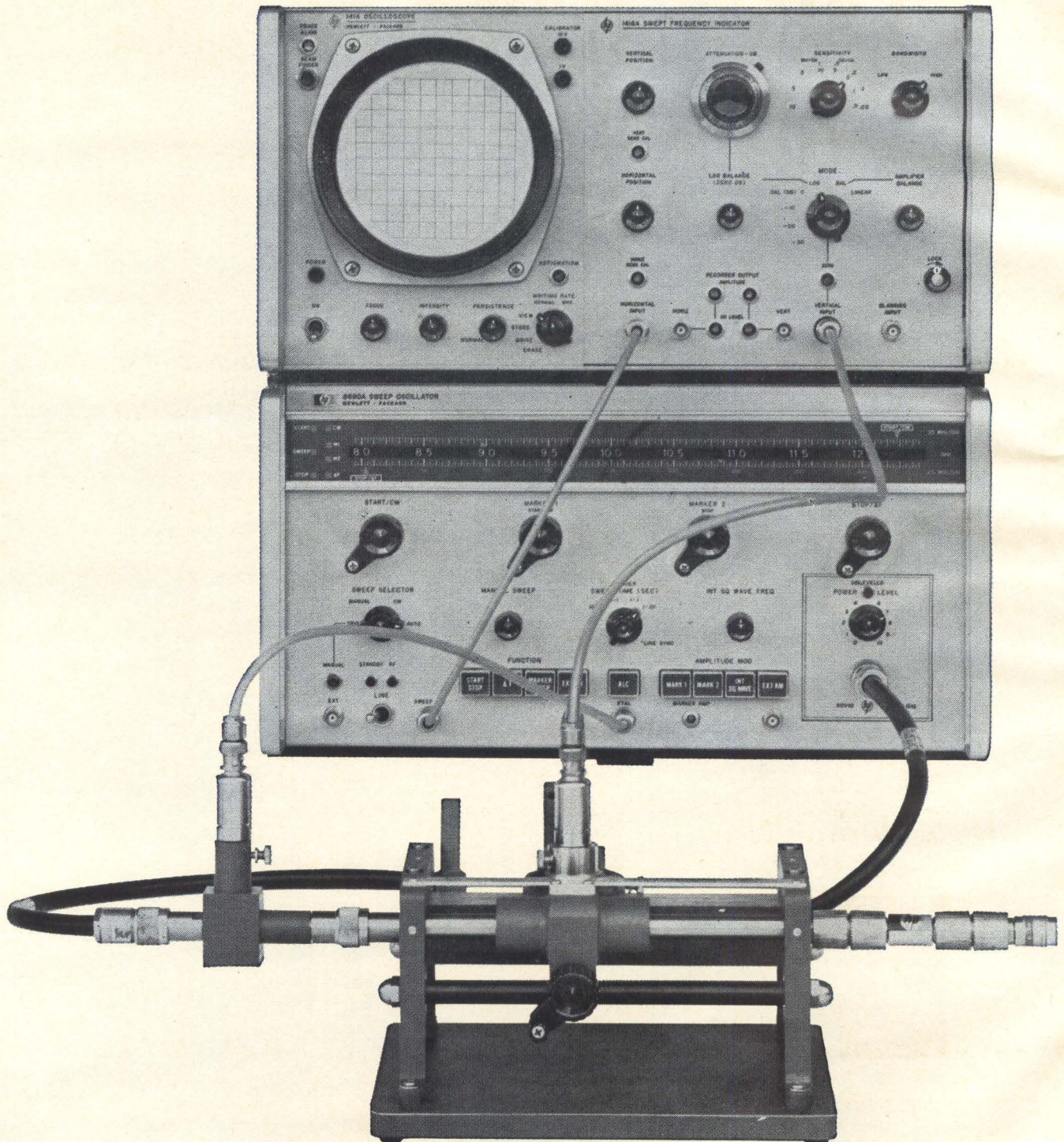

Swept swr measurements in coax from 2 to 18 GHz with slotted line accuracy and at low cost

From Hewlett-Packard: Fully compatible elements that answer your need for highest accuracy in wide-range swept swr measurements in coax.

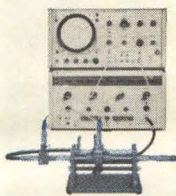

Swept Slotted Line System consisting of 816A Coax Slotted Section in 809C Universal Probe Carriage with 448A Slotted Line Sweep Adapter. Frequency coverage is 2 to 18 GHz for either 7 mm connectors (Amphenol APC-7) or Type N (male and female). Residual swr for APC-7: <1.02 to 8 GHz, <1.03 to 12.4 GHz, <1.04 to 18 GHz. Residual swr for Type N: <1.03 to 8 GHz, <1.04 to 12.4 GHz, <1.06 to 18 GHz. Prices: 816A, \$250; 448A, \$400; 809C, \$200.

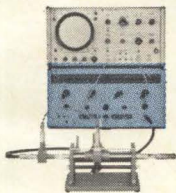

8690 Series Sweep Oscillator with plug-in RF units for octave or waveguide-band frequency "plug-in" economy. Start-stop sweep, marker sweep, calibrated Δf sweep, manual sweep; all with highest accuracy and linearity. PIN diode leveling and modulation. Prices: 8690A Main Unit, \$1550; RF Units for 1-40 GHz, from \$1575.

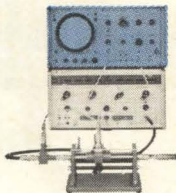

141A Variable Persistence Oscilloscope with 1416A Swept Frequency Indicator. Get and retain swr envelope quickly, easily, 1416A's logarithmic display gives swr in dB with high, 0.5 dB/cm resolution. Sixteen other plug-ins for 140A/141A Scopes result in greatest flexibility. Prices: 141A, \$1275; 1416A, \$675.

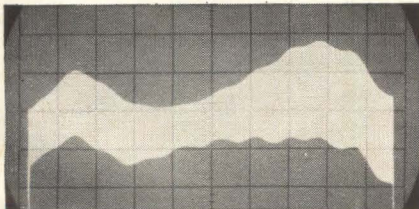

Swept swr envelope of coax device over full frequency range of 8690A/8694B Sweep Oscillator (8-12.4 GHz). Vertical calibration is 0.5 dB/cm. SWR at any frequency is simply the amplitude of the envelope.

The technique for making these precision broadband measurements is described in detail in Hewlett-Packard Application Note 84, yours for the asking. Data sheets are available from your local Hewlett-Packard field engineer. Or get all the data by writing Hewlett-Packard, Palo Alto, Calif. 94304, Tel. (415) 326-7000; Europe: 54 Route des Acacias, Geneva.

HEWLETT  **PACKARD**
An extra measure of quality

To get
high energy
circuitry
at the
lowest cost:
start here.

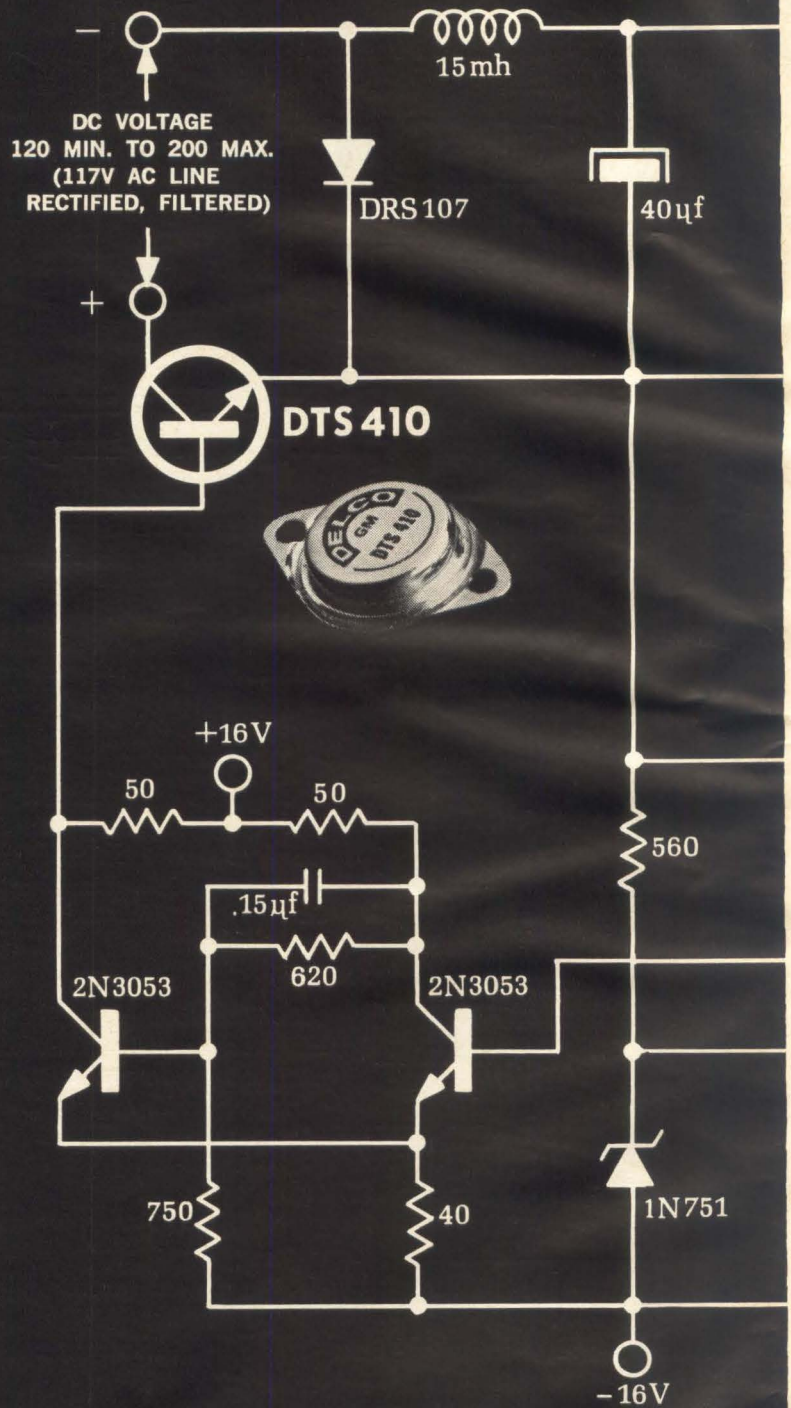

Application of Delco high voltage silicon power transistors:

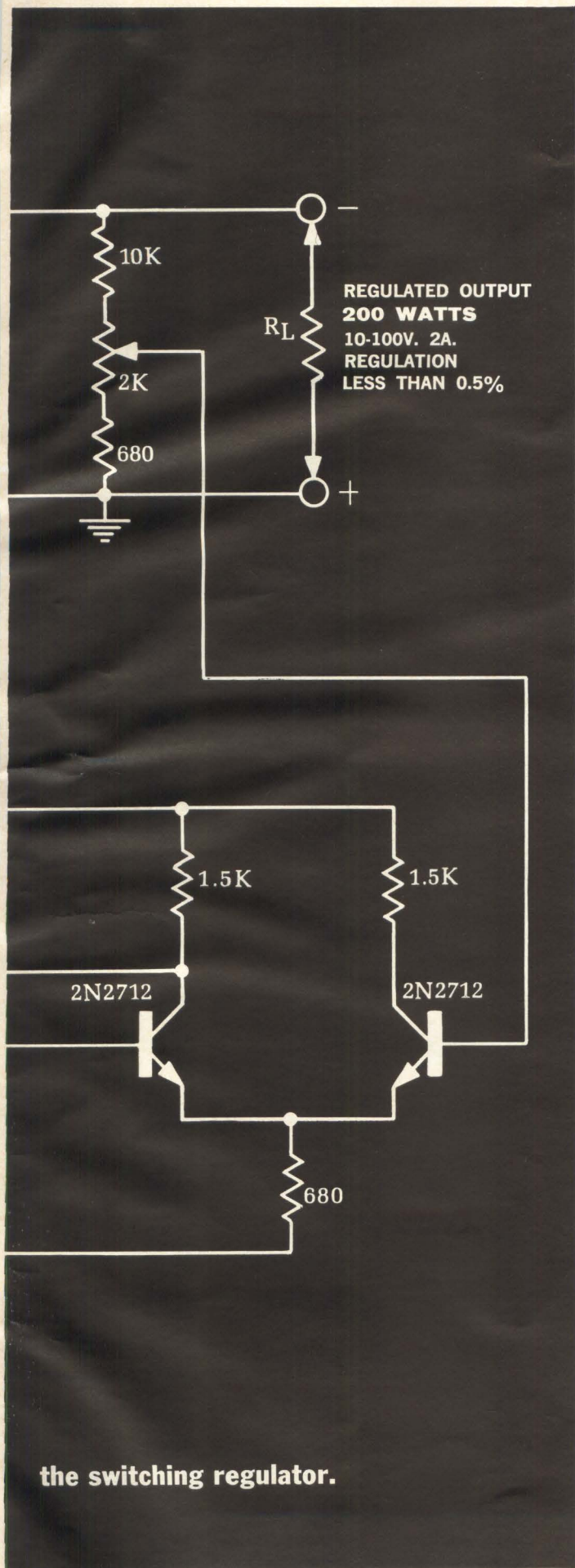

the switching regulator.

Start with circuit designs using Delco high voltage silicon power.

The simple switching regulator in the diagram at left turns out 200 watts (2 amps) output at efficiencies exceeding 85%. And it does it with just one series element working directly from rectified line voltage: the new Delco DTS-410 transistor at just \$1.95 each*.

Or if you need regulation of 250 volts DC and 400 watts output, the DTS-411 may be your answer. Cost? Just \$3.15 each*. And for extra-high voltage applications, there's the DTS-423, now priced at \$4.95 each*.

Now combine our new low prices with these other cost-cutting advantages of Delco high voltage silicon power transistors: you can reduce the number and complexity of input, output and filtering components. This means more compact circuitry, greater reliability and lower assembly costs.

These NPN silicon transistors are packaged in a rugged TO-3 case for low thermal resistance. Inside, they are mounted to withstand mechanical and thermal shock because of special bonding of the emitter to base contacts.

There's no need to be concerned about delivery. They are available right now in production quantities. Call us. Or order samples from your Delco distributor.

For details on the switching regulator circuit ask for application note number 39.

*Prices shown are for quantities of 1,000 or more.

TYPE	V _{CEO}	V _{CEO} (sus)	I _C Max	h _{FE} Min @ I _C V _{CE} =5V	Power Diss Max
DTS-410	200V	200V (min)	3.5A	10 @ 2.5A	80W
DTS-411	300V	300V (min)	3.5A	10 @ 2.5A	100W
DTS-423	400V	325V (min)	3.5A	10 @ 2.5A	100W

FIELD SALES OFFICES	UNION, NEW JERSEY** Box 1018 Chestnut Station (201) 687-3770	DETROIT, MICHIGAN 57 Harper Avenue (313) 873-6560	SANTA MONICA, CALIFORNIA** 726 Santa Monica Blvd. (213) 393-1465
	SYRACUSE, NEW YORK 1054 James Street (315) 472-2668	CHICAGO, ILLINOIS** 5151 N. Harlem Avenue (312) 775-5411	General Sales Office: 700 E. Firmin, Kokomo, Ind. (317) 459-2175

**Office includes field lab and resident engineer for applications assistance.

DELCO RADIO

Division of General Motors, Kokomo, Indiana



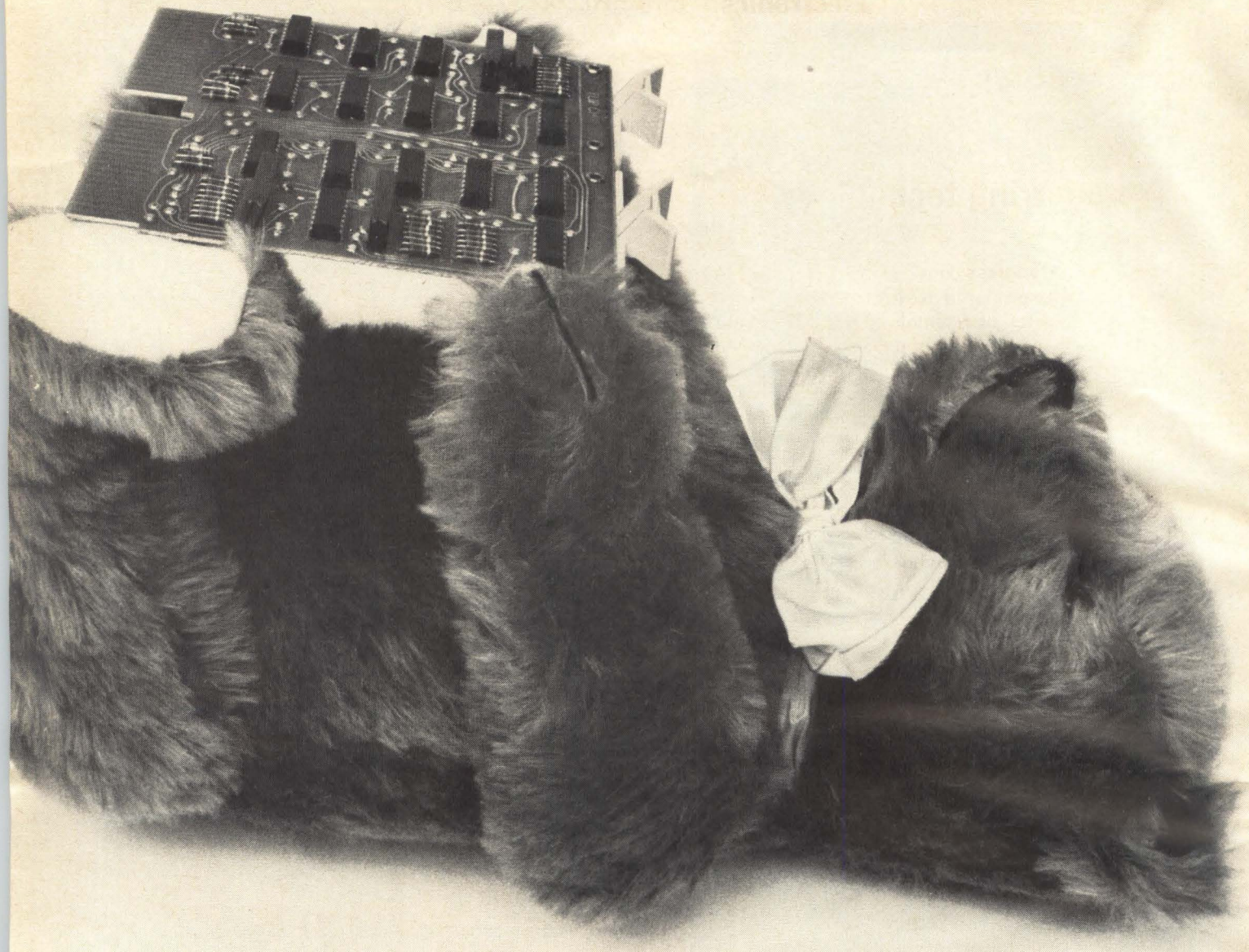

Security is having a module with a lot of compatible friends.

If you manufacture equipment, and price, delivery and reliability mean something to you, it's best to stay loose. Pick modules from a line that gives you options — so you can optimize the design for price, or speed, or ease of assembly, or something else that you're worried about.

DIGITAL'S module line is the broadest, most functional, most complete module line anywhere. Integrated circuits, discrete components, hybrids. More

than 120 of them. And each is electrically, physically, and logically compatible with each and every other.

It takes 330 pages of our Digital Logic Handbook to describe our series of Flip Chip* modules, details of the logic, and applications. It's yours for the asking.



And here's some added security: each of our modules is guaranteed for 10 years.

digital
MODULES • COMPUTERS

DIGITAL EQUIPMENT CORPORATION, Maynard, Massachusetts 01754. Telephone: (617) 897-8821 • Cambridge, Mass. • New Haven • Washington, D. C. • Parsippany, N. J. • Rochester, N. Y. • Philadelphia • Huntsville • Pittsburgh • Chicago • Denver • Ann Arbor • Houston • Los Angeles • Palo Alto • Seattle • Carleton Place and Toronto, Ont. • Reading, England • Paris, France • Munich and Cologne, Germany • Sydney and West Perth, Australia • Modules distributed also through Allied Radio

Editorial

Transferring technology

As the 90th Congress convened last week, a Senate subcommittee prepared to investigate an old subject: the transfer of technology from Government-sponsored research, mainly paid for by the Defense Department and NASA, to the civilian economy. Chances are that the subcommittee members, like other nontechnical people who have probed the subject before, will conclude that there has been practically no transfer.

But this conclusion would be wrong. Much of the technology used and polished in defense and space programs has spread and is spreading to civilian projects. Those who can't see it happening have been looking in all the wrong places.

What's wrong, of course, is that the investigators keep hunting for a transfer of hardware, rather than of techniques or knowledge. They conclude there hasn't been much transfer of technology because they can't report that the steering wheel developed for the Gemini space vehicle is being used on automobiles, or that the integrated circuits produced for the Minuteman missile are going into television sets, or that computers developed for a strategic bomber are flying commercial jets.

Yet there is plenty of evidence that Government-sponsored research and development has spurred technical progress in civilian areas. In fact, Government-sponsored R&D is the greatest single stimulus to technical progress today; nothing else is even a close second.

If the probers look for a transfer of techniques and knowledge in electronics, they'll find examples galore. The rapid evolution of the entire semiconductor industry from junction transistors to large-scale integrated arrays can be attributed mainly to military and space programs, which sometimes demanded new devices even when there was no reliability data for them or any assurance they could be made. Device-design rules, materials-processing skills and packaging know-how accumulated by semiconductor engineers working on military projects are being applied to the design and mass production of semiconductor devices for industrial and consumer applications. Without the pressure from these Federal programs, the transistor might still be a laboratory curiosity about which prospective Ph.D.'s write doctoral dissertations. Western Electric, at whose research arm—the Bell Telephone Laboratories—the transistor was invented in 1947, began putting the device into telephone systems only a couple of years ago.

Unquestionably, the Minuteman missile project launched integrated-circuit technology, and at such a speed that civilian concerns were able to use IC's

only two or three years after the first circuits went into military hardware. Although none of the same circuits developed for the missile's computers are being used in third-generation commercial computers, work on this program taught engineers and semiconductor firms how to design and build other circuits now in use in computers, instruments and consumer products. And what was learned about packaging IC's for this pioneering project is the basis for a lot of today's IC-packaging knowledge.

Military programs deserve the same kind of credit for the development of many of the more accurate instruments for higher frequencies. Once measuring techniques were perfected for high-performance military systems, commercial customers—mainly in the computer and communications fields—found they could use them too.

Government money played a starring role in the application and development of computers, too. As the biggest user of electronic data processing in the world, the U.S. Government has encouraged and paid for improvements in machines, new software and new ways to use data processing.

Probably the most valuable contribution Government programs have made has been an educational one: they have forced technical people to learn new developments, new techniques and new products. Since technology is transferred by people, the first step in a transfer has to be educational. Not until engineers know and understand the new technology can it be applied to civilian endeavors.

Thus, the fastest transfer in electronics takes place in companies that handle both Government and civilian projects. For example, work being done today to improve the resolution of tape recorders for military reconnaissance will soon affect the design of studio equipment for commercial telecasting. Development of high-frequency, high-power transistors for space communications systems will eventually lead to lower-cost high-reliability devices for civilian communications systems. And many of the techniques of command and control pioneered by the Defense Department are just now trickling into civilian applications.

If all this is true, why have there been so many investigations of the transfer of technology? The reason is that even believers in Government sponsorship of R&D have a nagging feeling that the transfer ought to be faster. They feel intuitively that overclassification of technical information, secrecy about nonessential programs and too many "need-to-know" restrictions hamper the normal and natural flow of technology. Proprietary interests in Government-backed research by contractors have also slowed the transfer.

But, on balance, the civilian economy of the U.S. has benefited hugely from the Government's giant expenditures for military and space programs. The clearest evidence of this is the fact that foreign concerns fear the technical repercussions of U.S. Government programs more than any other factor in their markets.

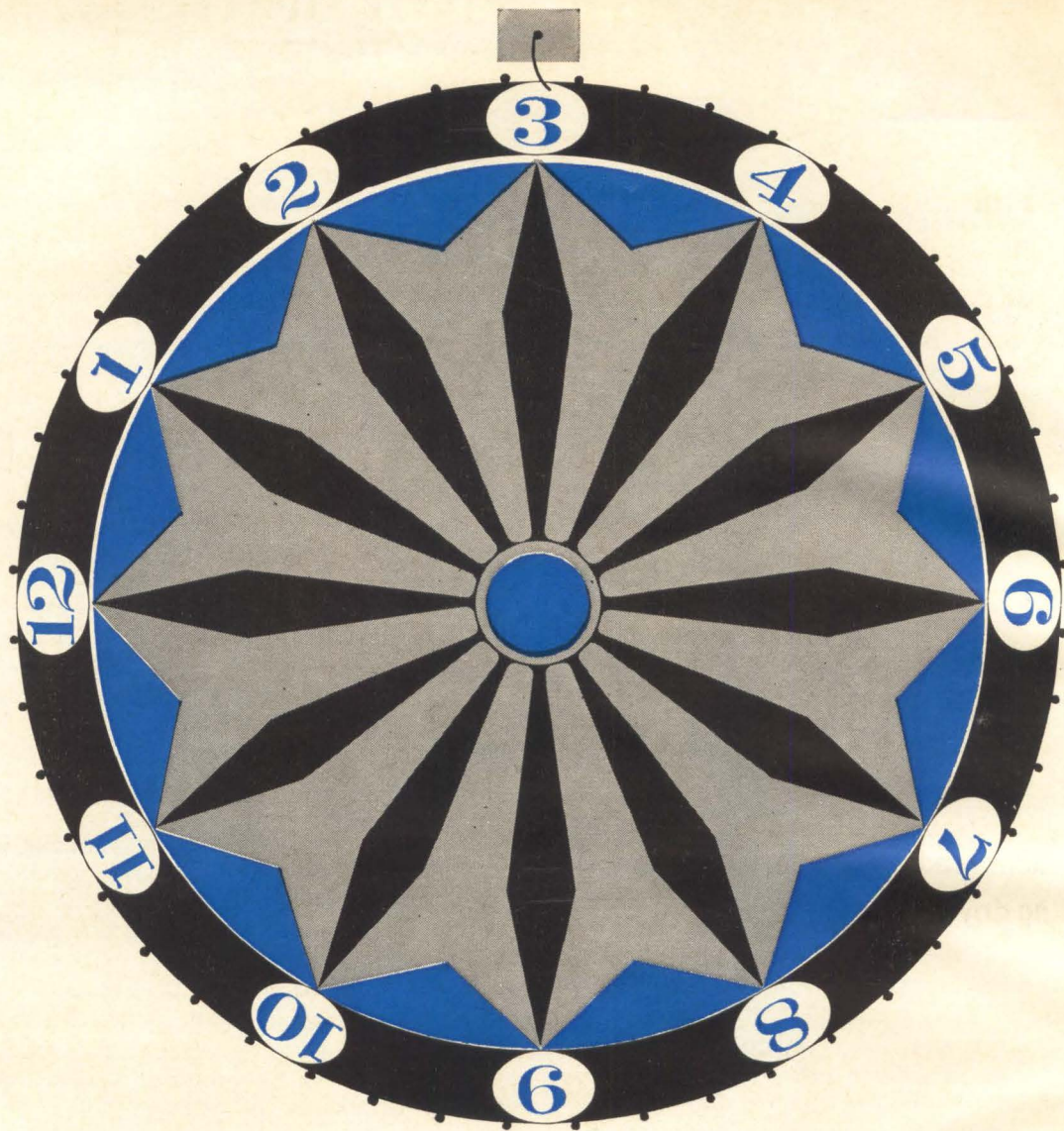

Take the Chance out of Electromechanical Design Problems



Clifton synchros and rotating components have the priceless ingredient of our long experience in the manufacture of an endless variety of standard and exotic units.

What do you need in the way of accuracy, size, type, temperature, radiation or corrosion resistance, terminals or leads, double ended shafts, tandems or BuWeps types?

We also specialize in the custom design and manufac-

ture of gyro pickoffs, single and multispeed, beryllium, stainless or aluminum housings. (Our units were chosen for the Apollo program.)

Clifton Precision Products, Division of Litton Industries, Clifton Heights, Pa., 215 622-1000.



Electronics Newsletter

January 23, 1967

**Work days cut
at TI, layoffs
slated by GE . . .**

Layoffs and curtailed work schedules are hitting some segments of the electronics industry.

Texas Instruments last week curtailed production of all semiconductors other than integrated circuits. The reason for the cutback: longer delivery schedules and a slowdown in orders.

At General Electric, a slowdown has cut through several electronic-appliance and semiconductor product lines. GE plans to furlough several thousand production workers in the next month; 600 have already been laid off. The reason: a slump in sales of television sets, dishwashers, ranges, semiconductors.

The work curtailment at TI is to continue for four weeks. The cutback, some sources say, was made to avoid laying off possibly as many as 3,000 workers. The firm's first two work shifts for semiconductor output have been cut back one-half hour, and the third shift has been reduced by 12 minutes.

Motorola last month laid off 75 to 100 semiconductor production workers. [For more on semiconductor producers' problems with slumps and prices, see page 142.]

**. . . as unions ready
organizing drives**

The layoffs and work-week cuts come at a critical time. At TI, the Teamsters Union is said to be pressing to sign up some 23,000 Dallas-based workers. Earlier efforts by the union were unsuccessful. And in northern Santa Clara County, Calif., where most of the San Francisco Bay area electronics companies are clustered, the International Association of Machinists is making an organizing attempt. Next month the union will again try to sign up 2,600 workers at Fairchild Semiconductor after two earlier failures.

**Government weighs
antitrust charges
against IBM**

The Justice Department has launched an investigation into the state of competition in the booming computer industry, and the probe centers on the International Business Machines Corp.

The Government's antitrust lawyers are looking into complaints by IBM's competitors that the industry's undisputed giant has engaged in predatory pricing practices and unfair sales and patent-licensing tactics—all of which may violate the Sherman Antitrust Act.

So far, the Government hasn't shown its hand—publicly. It has yet to file a civil investigative demand, which would amount to a subpoena and would require IBM to supply specified documents.

Although IBM declines to concede it, the company controls about two-thirds of the world's computer market.

One charge made against IBM is that in attempting to keep a tight hold on the market it has signed cross-licensing agreements with the number two firm in the industry (in terms of unit sales), the Sperry Rand Corp.'s Univac division. Other competitors maintain that IBM won't sign similar agreements with them because they haven't enough to offer IBM in return.

Other complaints being investigated concern IBM's pricing and sales policies. Competitors complain that IBM drops its prices on those computer lines meeting competition, but keeps prices up in other lines, and

Electronics Newsletter

deliberately cools competitors' sales prospects by announcing the introduction of new computers long before they become available.

TI developing monolithic IC for microwaves

A Gunn-effect oscillator, a factor-of-three multiplier and a balanced mixer, all monolithically combined on a single gallium arsenide chip, are the basis of a 94-gigahertz microwave receiver being developed by Texas Instruments for the Air Force.

The Gunn device, which will oscillate at about 30 Ghz, and the other active devices, will be formed from epitaxial layers grown through holes etched in the semi-insulating gallium arsenide substrate. The substrate crystal has a resistivity of about 10^8 ohm-centimeter, imparted by doping it with chromium. Interconnections on the chip will be made by micro-strip lines [See cover and page 76].

And in a program for the Army, TI is developing a technique for growing islands of germanium in a gallium arsenide substrate. If perfected, this could lead to integrated microwave circuits with extremely low noise, since active germanium devices have less noise than either silicon or gallium arsenide.

Megawatt radar from plasma

A new source of radar power, producing megawatts, has been developed by Ikor Inc., a small company in Burlington, Mass. Pentagon officials took a look at the system—reportedly based on plasma principles—earlier this month, and were briefed on the technique.

New York gives go signal to stalled traffic control

New York City's traffic control system, mired for months in a dispute over the radar sensors that keep tabs on the traffic, is moving along again. The Sperry Gyroscope Co. has a \$10 million contract to develop and install computer traffic controls in selected areas of the city but ran into trouble when the city's traffic commissioner maintained that the sensors failed to operate within the required 2% error margin. For this reason the city refused to accept the entire package—computers, sensors and related equipment. Suddenly, without explanation, the city announced that the sensors met the specs; Sperry also refused to elaborate. But an engineer close to the project summed it up this way: "We're still working with a 2% margin of error, only it's a more liberal interpretation of 2%."

For Sperry, a subsidiary of the Sperry Rand Corp., the contract is important both for the prestige and the money. After the initial \$10 million of traffic control gear is installed, the city plans to spend another \$100 million or so on more equipment.

Addenda

Engineers at NASA's Goddard Space Flight Center plan to improve the nation's weather satellite system by using microwave radiometers to measure ground temperature through clouds. The currently used infrared systems cannot penetrate cloud formations. The sensors, being built by the Space-General Corp., will be tested aboard an aircraft in April. They operate at a wavelength of 1.6 centimeter. . . . Comsat's second Intelsat 2, which was orbited this month, will start commercial service over the Pacific about Jan. 26. Requests for channel space have already exceeded the satellite's 240-circuit volume.



We've got a chip on our shoulder!

Not enough of you know that we are one of the industry's leading manufacturers of high-quality 930 DTL digital integrated circuits. Well, we are.

Who has a larger more modern facility devoted exclusively to the manufacture of these kinds of microcircuits? (We don't dilute our efforts with the manufacture of a thousand other semiconductor components.)

Who has better yields in this DTL line? (Our manufacturing capability is unsur-

passed, and we invite you to inspect it for yourself.)

Who can give you better delivery on these products? (It's pretty hard to beat our *immediate* delivery!)

Who can offer you better prices? (Try us on a quantity bid.)

Who has a more substantial name behind them than the "Stewart-Warner" name—a name associated with the manufacture of quality products for more than 85 years? (We'll be around to keep you supplied with

microcircuits for years to come.)

Why have we got a chip on our shoulder? Not enough of you have tried our 930 DTL monolithic circuits, and that's too bad. We know you'd like our product, available in all the standard packages. So why not help us take the "chip" off our shoulder and put it in your equipment. Send for our 20-page "Composite Data Book" for the industry's best coverage of the 930 DTL series.

STEWART  WARNER
MICROCIRCUITS, INC.
SUBSIDIARY OF STEWART-WARNER CORPORATION

The ultimate in Q JFD Uniceram capacitors

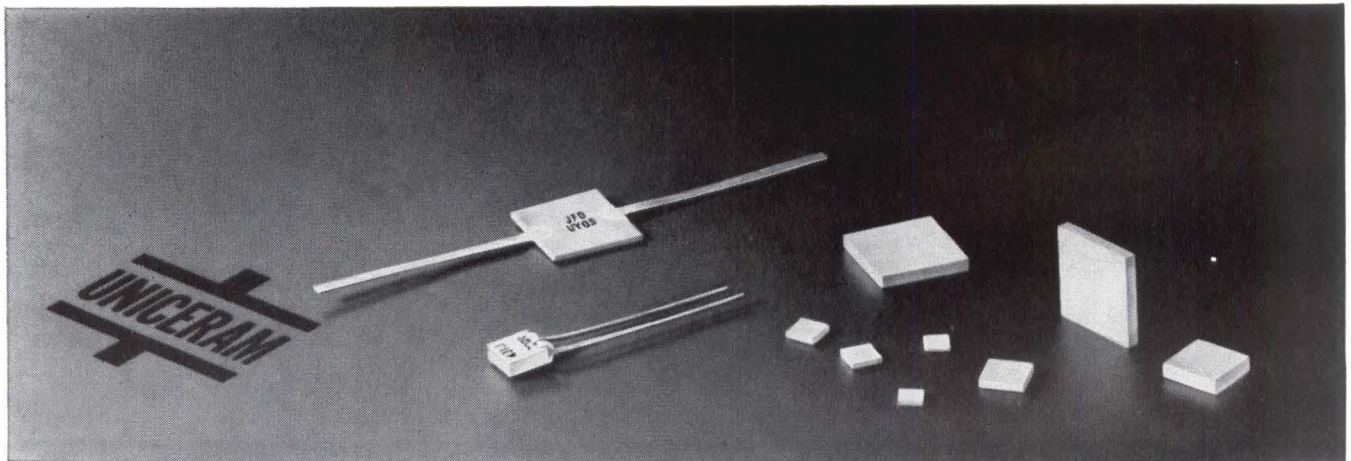

Capacitors shown enlarged 25%

Glass encapsulated or unencapsulated wafer uniceram monolithic High Q ceramic fixed capacitors—offer a high ratio of capacitance per unit volume. They combine exceptional stability and a guaranteed minimum Q in a smaller size package than competitive units.

Over 1,000 glass encapsulated models, with capacitance values from 0.5 to 3000 pf, provide the ul-

timate in High Q—proven reliability and stability. All models meet applicable requirements of MIL-C-11272B.

Uniceram High Q capacitors are also available as wafers with metalized edges. These lower-cost units in the same capacitance values offer the same outstanding electrical properties. These wafers, or chips, ideally suited for hybrid integrated circuits,

can be soldered directly to printed circuit boards or used as discrete components.

A High K series of Uniceram ceramic fixed capacitors with up to 1 mfd capacitance is also available. These glass encapsulated units meet applicable requirements of MIL-C-11015C. Volumetric efficiency . . . up to 48 mfd/in³.

Write for Catalog UNM 65-2.



"TODAY'S COMPONENTS BUILT FOR TOMORROW'S CHALLENGES"

JFD ELECTRONICS CO. / COMPONENTS DIVISION • 15th Avenue at 62nd Street • Brooklyn, New York 11219 / Phone 212-331-1000
Sales Offices — Arcadia, California / Chicago, Illinois / Baltimore, Maryland / Saxonville, Massachusetts / Brooklyn, New York
New Hartford, New York / Cincinnati, Ohio / Philadelphia, Pennsylvania / Pittsburgh, Pennsylvania / Paris, France / Azor, Israel

High Power Pulses

**for non-destructive testing
of semiconductors**

You name your own pulse parameters; the rest is up to the Model 350. Anything up to and including 20KW is yours with continuous variability of all pulse parameters, plus impedance-matching, polarity-inverting plug-ins for

pulse modulating microwave tubes

almost any load between $1/10 \Omega$ with 400 amperes and $20,000 \Omega$ with 19 KV. And you'll find it easier to operate than most ordinary low-power lab pulse generators.

**testing the magnetizing current
of pulse transformers**

We can have a data sheet in the mail to you within nano-seconds. Send your name today!

laboratory experimenting

560 Robert Ave., Santa Clara, Calif. 95050 • (408) 244-7370 • TWX 910-338-0114

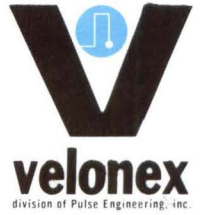

Output to 2,000 volts neg.
10 amps at 200 ohms

Ripple negligible

Droop less than
0.05% per μsec

Pulse width 0.1 to 200 μsec

Pulse repetition rate 3 to 100,000 pps

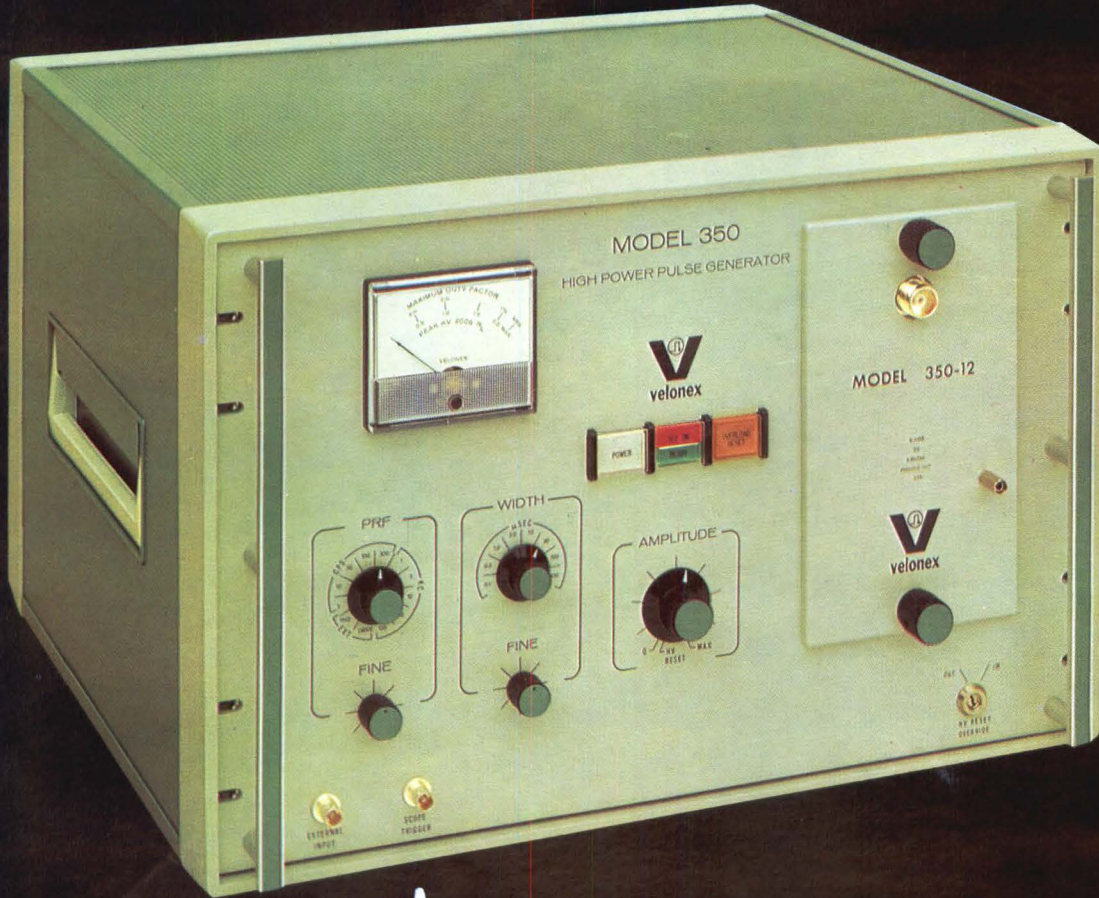

Duty Factor 1% at 20 KW

Rise time < 35 nanosec

PRICE \$3,990
plus plug-ins

Fall time < 50 nanosec

Monsanto and you: silent

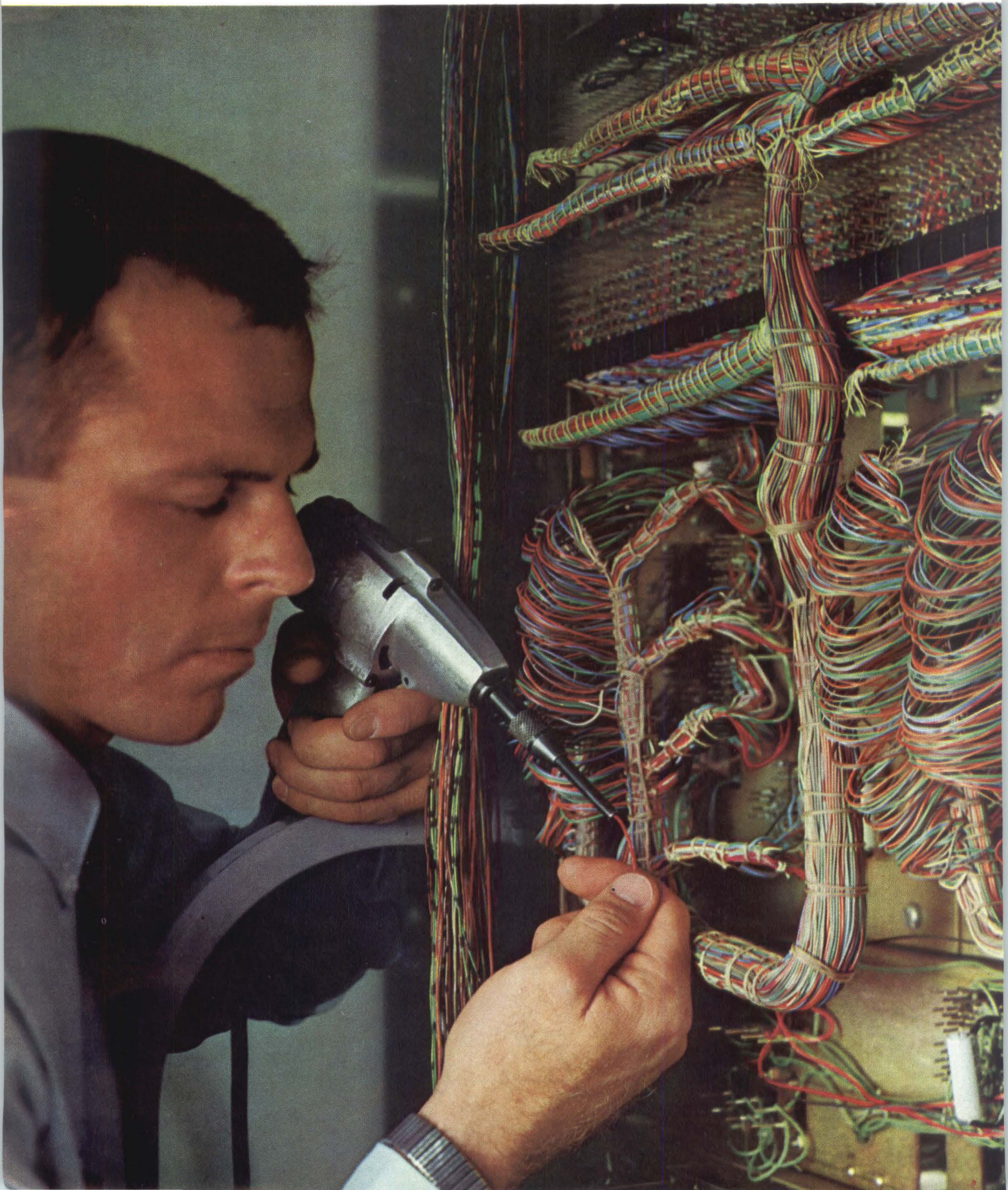

partners for 20 years

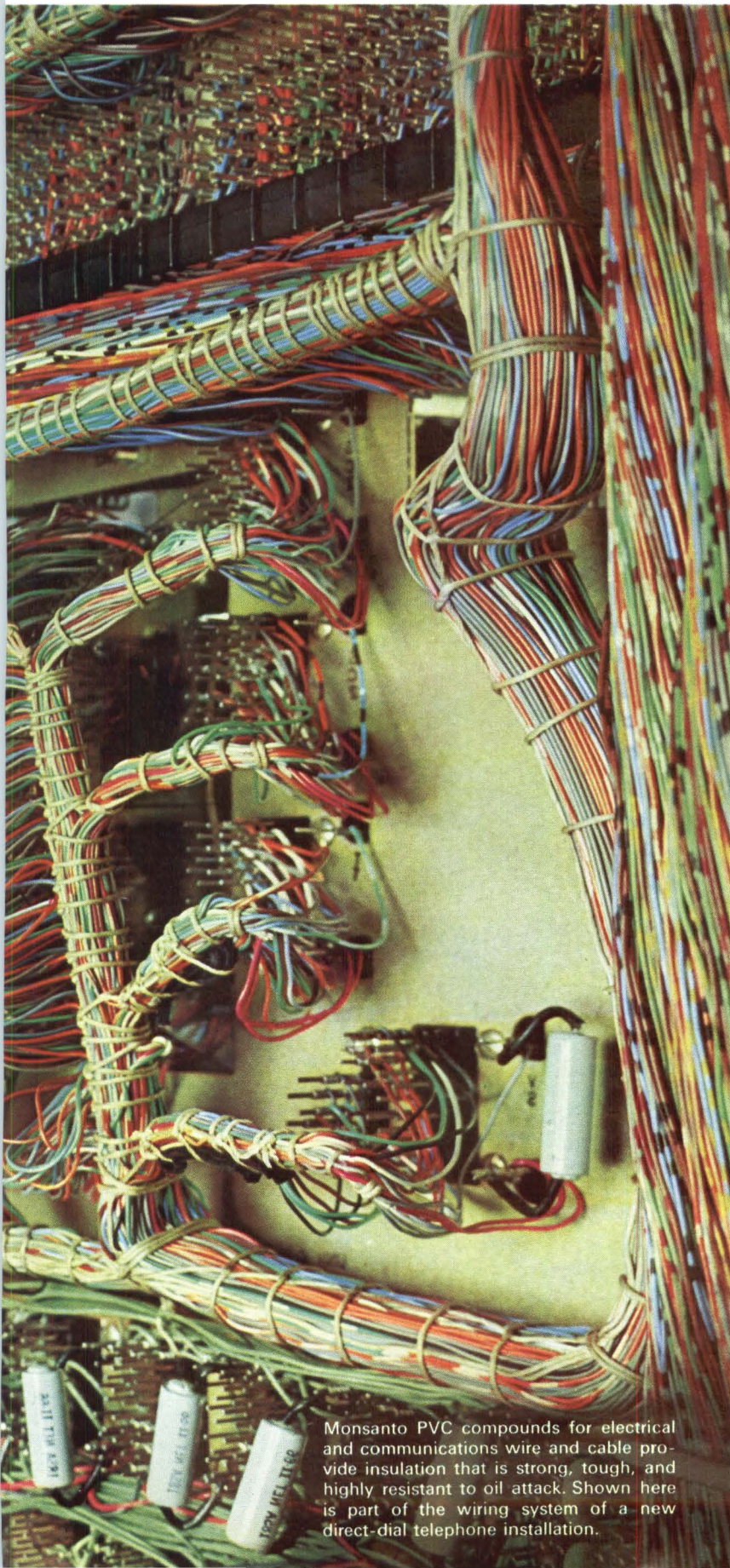

Monsanto PVC compounds for electrical and communications wire and cable provide insulation that is strong, tough, and highly resistant to oil attack. Shown here is part of the wiring system of a new direct-dial telephone installation.

Monsanto's vast knowledge of plastics technology, applied to polyvinyl chloride, transforms it into versatile, reliable insulation for wiring applications that are basic to the electronics industry.



MONSANTO COUNTER/TIMER 1010

You won't find our name on PVC wiring insulation, although Monsanto's contributions to high quality, utterly reliable insulation span two decades. Monsanto is expert in the science and technology of plastics; application of this knowledge makes PVC perform in your electrical applications.

Our name *does* appear on the growing Monsanto line of new state-of-the-art instruments. Monsanto counter-timers, pulse generators, and digital voltmeters are applications-oriented, precisely accurate, and highly reliable. They are designed by Monsanto engineers whose depth of knowledge shows in the high performance characteristics of every design. Each instrument symbolizes a continuing Monsanto tradition: use of fundamental research disciplines to develop sophisticated products of extraordinary value and technical merit.

We'd like to tell you more. We now have 33 fully staffed field offices; call your nearest Monsanto Field Engineering Representative for a demonstration. Or write to Monsanto, Electronics Technical Center, 620 Passaic Avenue, West Caldwell, New Jersey 07006. Or telephone: (201) 228-3800, Extension 34.



ELECTRONIC
INSTRUMENTS

Circle 31 on reader service card

More than 1000 hours from d-c to 1.5 MHz

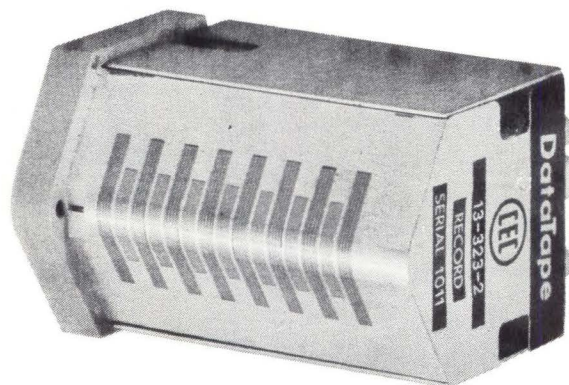

Now try to get that through your head

You can... with a CEC Magnetic Recording Head.

In fact, considering that these recording heads last up to five times longer than any others, the 1000 hour guarantee seems rather conservative. In virtually every case, a CEC head will surpass a thousand hours with little or no indication of wear.

The reason: CEC recording heads are of a unique material and solid metal pole-tip design which completely eliminates the weakness of conventional lamination and rotary head designs.

This has resulted in superior per-

formance at frequencies to 2 MHz and a minimum of wear and cleaning.

There is a CEC head for every analog and digital recorder.

Whatever make or model recorder you may now be using, CEC has the head to make the most of it, irrespective of the interface parameters. The "family" consists of more than 100 different recording heads, *all* with the same design advantages. Consequently, it is now possible to obtain state-of-the-art recording without replacing the basic instrument.

How were we able to achieve this

breakthrough in head design? Through experience. CEC has not only been making magnetic recording heads longer than anyone else, but was the first to produce them on a quantity basis. *And* — because CEC uses *precision* machine construction where others rely on hand assembly.

For complete specifications and all the facts about this complete line of recording heads, call or write your nearest CEC field office.

CEC/DATATAPE PRODUCTS

Pasadena, California 91109

 **BELL & HOWELL**

The Switch to IC's

A Package Deal

So you've decided that integrated circuits are here, and you're going to use them in your very next design. Now you have some basic problems to solve. First, of course, is the question of which family of integrated circuits you should use. This will depend largely on your requirements and will involve you in trade-offs between performance (speed, power, etc.), cost, and availability. (In future application notes in this series we'll attempt to lay down some guidelines you can follow in making your selection.) Next is the question of packaging. Most IC families are available in four basic package types: transistor packaging (metal), transistor packaging (epoxy), ceramic flatpak, and Fairchild's own Dual in-line package (DIP). See reverse side for illustrations.

TRANSISTOR PACKAGE (METAL): When integrated circuits first came out, manufacturers turned to the same packaging they had used all along. They simply added 5 more leads to conventional TO-5 or TO-18 cans and came up with a highly satisfactory and economical package for integrated circuits. The metal can has some obvious advantages: it is hermetic, withstands heat, and most important, perhaps, it requires no new production techniques on the part of the user. If you are using transistors, you can use integrated circuits in transistor packages without having to make any significant changes on the production line. The main limitation of the transistor package is the number of leads. It is limited to 10, and consequently you will find that some of the more complex integrated circuit functions are not available in this type of packaging.

TRANSISTOR PACKAGE (EPOXY): The epoxy package, like the metal can, is an extension of transistor technology. Its primary and considerable advantage is low cost, and it is the most economical of all IC packages. For this reason, it is used extensively in many industrial and consumer applications. Like the metal can, the epoxy package is limited to 10 leads. Additionally, it can not pass hermeticity tests under the extreme temperature conditions required by mil-specs, and its operation is normally limited to the middle temperature range: 0 to 70°C. This is still a broad enough range for most industrial applications, however, and this form of packaging is highly popular.

CERAMIC FLATPAK: The 1/4" x 1/4" Cerpak® was specifically created for integrated circuits and is associated with their most exotic uses. It is the smallest of the IC packages and has 14 leads, thus permitting the most dense usage of components. In other words, it offers the most functions per square inch. It is also hermetic, heat resistant, and impervious to other environmental hazards. On the other hand, the Cerpak is expensive to buy and to use. It does not lend itself to mass production techniques such as flow soldering: leads have to be position welded. For these reasons the Cerpak is used where both small size and environmental resistance are required, as, for example, aircraft and satellite equipment.

DIP: The Dual in-line package is a Fairchild innovation, specifically designed to overcome the limitations of both transistor packaging and the ceramic Cerpak. It currently offers up to 16 leads, rugged construction, a true hermetic seal, and ease of handling. It can be machine inserted and flow soldered, and it lends itself to all the standard industrial production methods. The trade-off is space: the DIP occupies more space than the Cerpak; because of its 16 leads, however, it can accommodate dual functions as compared to transistor packages.

TO SUMMARIZE: If your equipment must be small and also withstand extreme environments, use the Cerpak. If you're not crowded for space, use the Dual in-line. And if your equipment operates in mild environments, you will benefit from the economy offered by the epoxy package. And don't forget the IC version of the TO-5 can: it is often the easiest way to make your transition from discrete components to integrated circuits.

Time Code Generator

In essence a time code generator is a highly accurate clock. It produces time code signals which are used by data acquisition systems to correlate information received from multiple sources. For example, a system may receive inputs from cameras, recorders, test instruments, and computers, and record all these inputs for future analysis. The time code signal provides a reference scale against which the various inputs can be synchronized when they are retrieved.

Electronic Engineering Company of California (EECO) manufactures a time code generator known as the EECO 911. This precision instrument generates up to 5 codes simultaneously, and displays time in days, hours, minutes and seconds. The display can be preset to a selected standard, such as local time, Greenwich mean time, or any other desired reference.

A 1MHz oscillator provides the internal frequency standard, which is divided by the logic and stored in a digital register which accumulates the time of year. The register is scanned periodically to produce a serial code representation of the accumulated time. The counting logic is implemented with Fairchild's Series 960 C_μL (Counting Micrologic) circuits, and these are driven by Series 900 RT_μL (Resistor-Transistor Micrologic) circuits.

The modular design of the instrument permits changing codes by simply interchanging a circuit card. Thus it is possible to choose the five codes generated from a wide variety of standard time codes, as required by the individual application. The low power consumption permits complete backup, using a 12V battery which can operate the instrument for an extended period of time (from 8 to 75 hours, depending on battery size and operating conditions).

The use of integrated circuits in this application, according to EECO, has resulted in a smaller, more compact unit. It has been possible to reduce the instrument's height by 30%, its weight by 50%, and its power consumption by 40%.

These improvements in operating features, size and versatility were effected while manufacturing costs were reduced by 25% over previous EECO models.

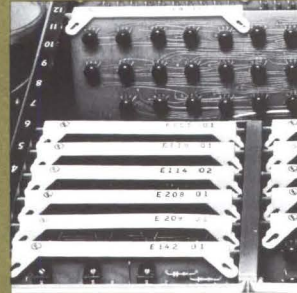

Codes may be changed by simply changing plug-in circuit boards.

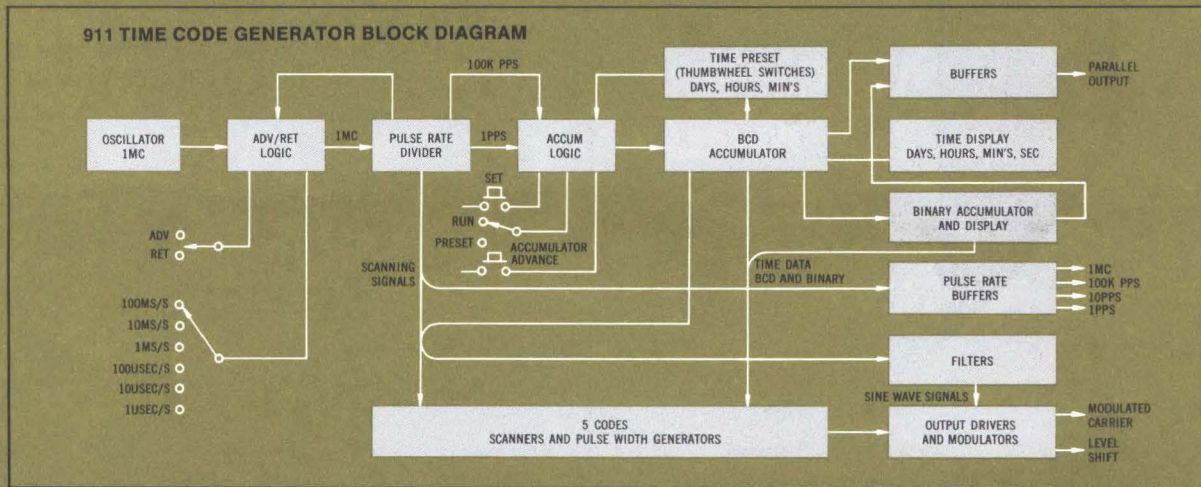

TYPICAL INTEGRATED CIRCUIT PACKAGES

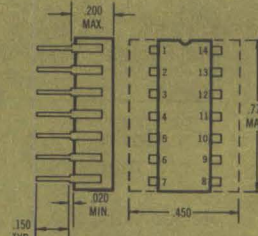
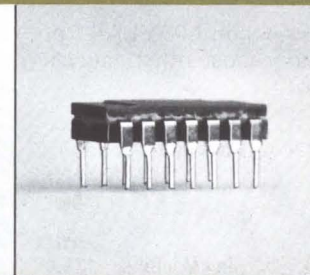
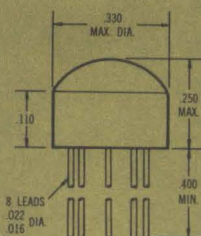
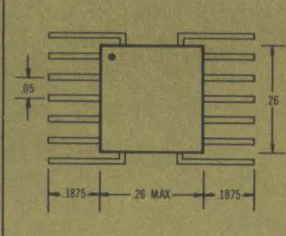
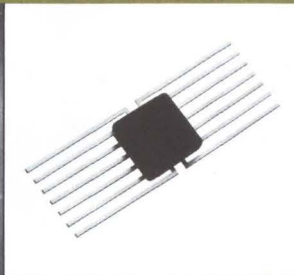
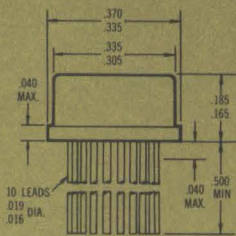

FAIRCHILD
SEMICONDUCTOR

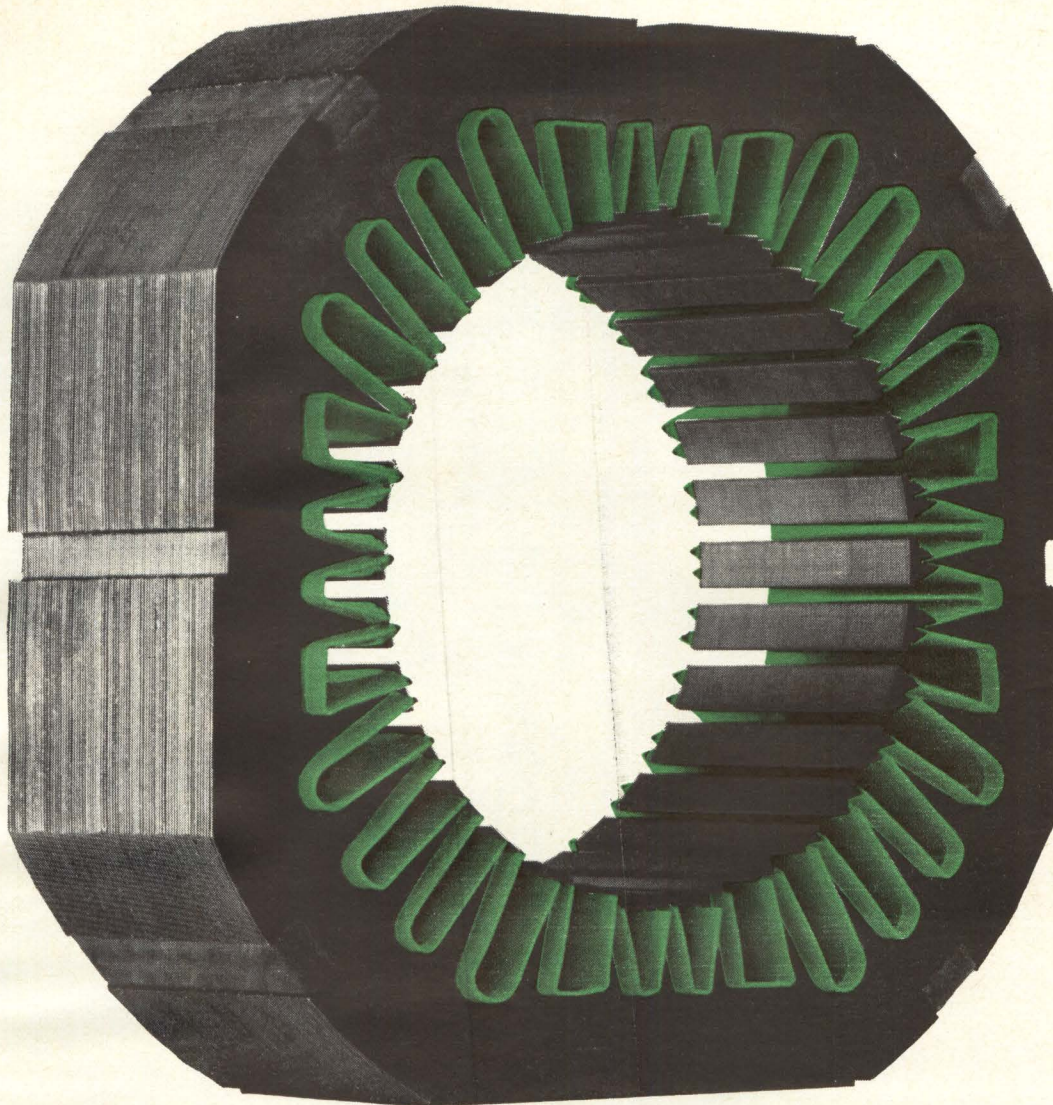

**This stator costs less
thanks to a more expensive insulation...
MYLAR®**

Pound for pound, MYLAR* polyester film costs just a little more than most other materials. But stator for stator, it costs less.

Motor Stators insulated with 7½-mil. MYLAR compared with powdered-resin coating

	Cost Per Pound		but	Cost Per Stator	
	MYLAR	Powdered Resin		MYLAR	Powdered Resin
Two-Speed Washing Machine 1/3 HP	(\$1.40)	(\$1.25)		\$0.07	\$0.21
General-Purpose, 1/4 HP	(\$1.40)	(\$1.20)		\$0.04	\$0.09
Two-Speed, General-Purpose 1/3 HP	(\$1.40)	(\$1.20)		\$0.08	\$0.13

The same is true for relays, bus-bars, ballast transformers, step-switches, and many other electrical/electronic applications.

It is possible for you, too, to lower your insulation costs because less MYLAR is required for a given insulation value. The high cut-through resistance and lasting durability of MYLAR enables you to use thinner gauges.

With thinner, flexible MYLAR you can replace heavier, bulkier insulation materials such as rubber, paper and resins. You can save on the weight, size and cost of your components.

MYLAR has excellent resistance to most chemicals and moisture, and can withstand temperatures from -60°C. to +150°C. In addition, many systems using MYLAR as electrical insulation have received full Underwriters' Laboratory approval for Class A and Class B applications.

Find out how you can save costs and improve reliability. Mail the coupon today for a complete Fact File on MYLAR.

*Du Pont's registered trademark for its polyester film.



Du Pont Company, Room 3886C
Wilmington, Delaware 19898

I'd like to know more about MYLAR. Please send me a Fact File.

NAME _____

COMPANY _____

ADDRESS _____

CITY _____ STATE _____ ZIP _____

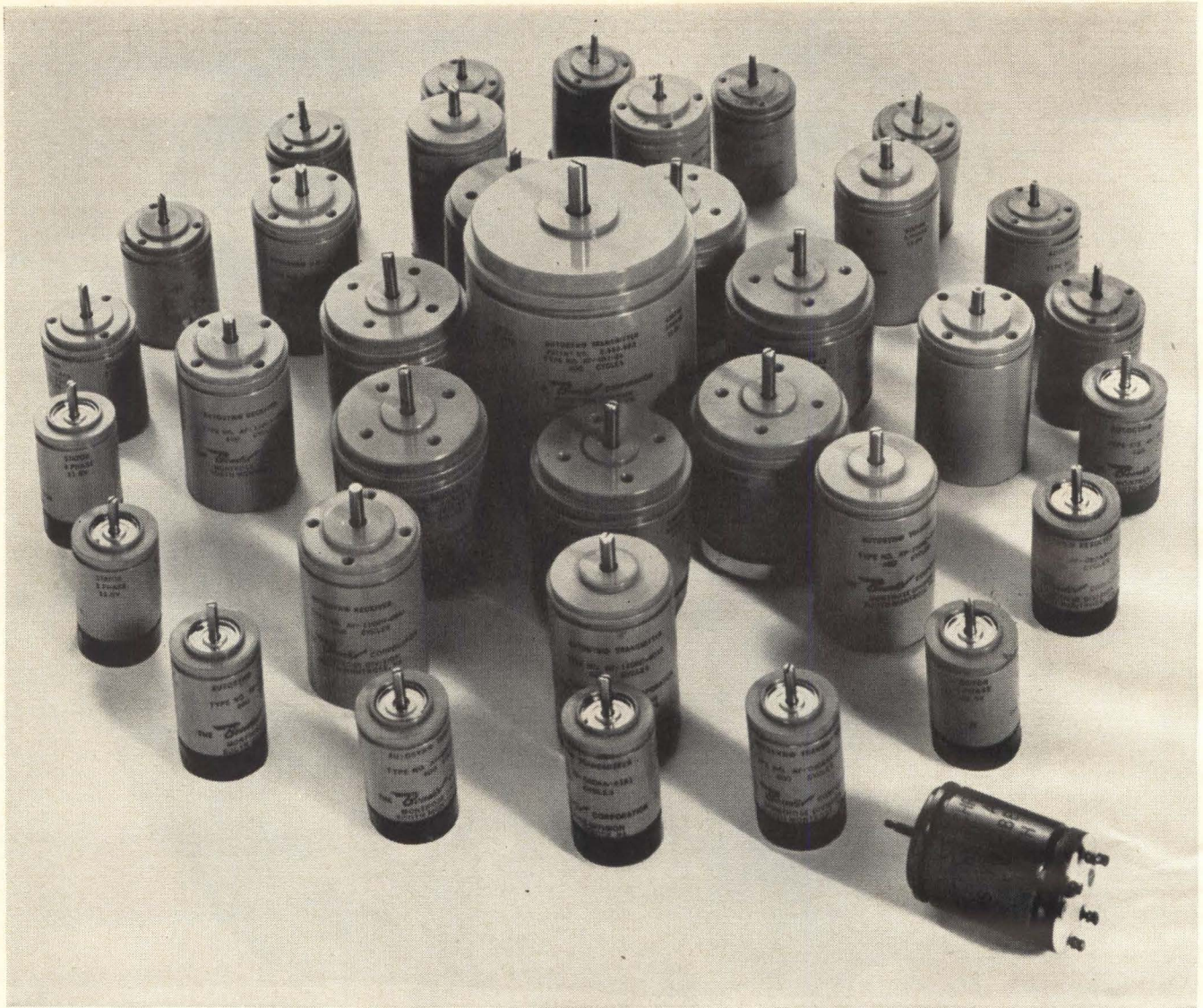

Just when we've solved your synchro problem, somebody comes up with a new one.

Designing and producing Autosyn® Synchronizers to fill the everyday needs of our customers isn't enough. We also specialize in meeting the unique need and solving your specific requirements.

Fact: engineers needed smaller, lighter-weight synchronizers for space-critical designs. Solution: the new series of 16 Size 08 Autosyn Synchronizers.

Fact: supersonic aircraft applications demanded synchronizers that could consistently operate at ultra-high

temperatures. Solution: eleven different Autosyn Synchronizers will perform accurately at temperatures up to 800°F.

Fact: we've built many of them to be corrosion- and radiation-resistant.

AUTOSYN® SYNCHROS

Size	Max. Diameter (In.)	Typical Weight (Oz.)	No. of Models
08	0.750	1.3	16
10	0.937	1.7	25
11	1.062	3.2	29
15	1.437	4.7	24
22	2.161	18	5

And we're able to provide synchronizers with tolerances as close as 50 millionths of an inch.

Meeting all needs has been our way of business since we began business in the 1920's. That's why the Bendix line of Autosyn Synchronizers (and Mil-Spec synchronizers) is the most extensive you can find. And it's why we're ready to solve your synchro problem. Try us. Phone (717) 278-1161, Montrose, Pennsylvania. Or write for our new 42-page catalog.

Montrose Division



Electronics Review

Volume 40
Number 2

Lasers

Carbon dioxide shows gains

With its enormous and growing power and ease of focusing, the carbon dioxide laser is emerging as the workhorse in industrial, military and research fields.

Next month, the Autonetics division of North American Aviation Inc. will complete a carbon dioxide laser with a continuous-wave output of 4,000 watts. And the Raytheon Co.'s research division has just announced that a CO₂ laser has produced 1,200 watts, c-w, at an efficiency of 17%. This laser has fractured granite and burned holes in bones, and Raytheon plans to produce even higher-output lasers in the next few months.

The radiant energy produced by these units, in watts per square centimeter, is much higher than that of the sun.

Far ahead. Gas lasers have generally outpaced solid state devices in c-w power, and the CO₂ laser is far more powerful than other gaseous types. With the exception of ionized argon lasers, which have achieved c-w outputs of 50 watts, the others produce beams in milliwatt ranges at efficiencies of less than 1%.

The CO₂ laser still presents problems in the areas of control, reliability, ease of operation and packaging, but it has so much promise that nearly every electronics systems company in the nation is working on it.

The Autonetics laser is being developed for radar applications, and the company says companion efforts are being directed toward receivers for 10.6-micron output.

Raytheon's 1,200-watt laser has a dual-tube or "folded" configuration. The 10-meter-long tubes are parallel and optically coupled, giving an effective lasing length of 20 meters.

Power packing. "The effort now is toward even higher power at higher efficiencies in a smaller package," says David A. Whitehouse, a scientist at the Research division. Whitehouse's principal project at the moment is for the Army Missile Command, but the division is also developing CO₂ laser radar transmitters for the Defense Department's Advanced Research Projects Agency.

Unfocused beams from the 1,200-watt laser are being used to crumble rock and granite by civil engineering students at the Massachusetts Institute of Technology. The possible use of the CO₂ laser as a supplement to drilling and dynamiting is being investigated for the Commerce Department as

part of the technical studies on a high-speed underground transportation system from Boston to Washington.

In recent weeks, the possibilities of the laser in excavation operations has attracted the attention of the Ingersoll-Rand Co., a maker of drilling equipment. And last week, Raytheon demonstrated the CO₂ laser's capabilities to the Joy Manufacturing Co., a producer of mining machinery.

Zap! It's clear from the contracts awarded by the military that the weapons potential of these devices is being explored. Says one research scientist: "Even if at this stage a field-type CO₂ laser couldn't kill a man at long range, it could set his clothes on fire—a serious

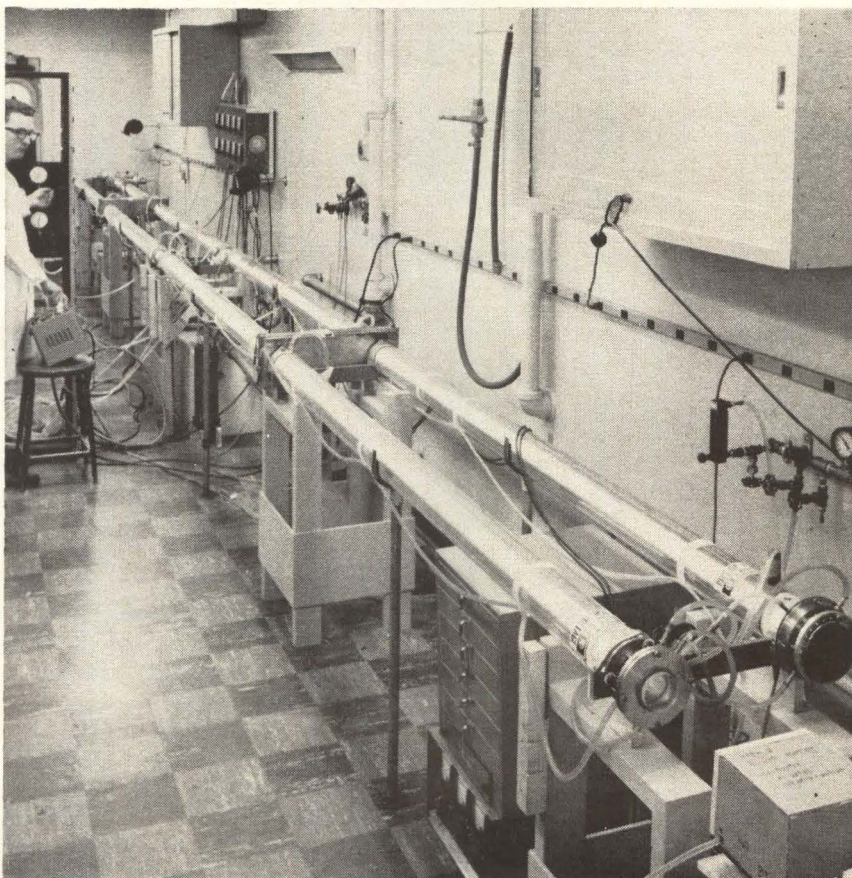

Dual-tube laser developed by Raytheon produces 1,200 watts, continuous-wave. By optically "folding" the tube, the laser's length is effectively doubled.

psychological hazard for enemy troops, particularly since the output is invisible."

To make the laser practical for land-mobile and airborne applications, several companies are working on techniques for "folding" or stacking the tubes. With such a technique a laser's effective length is maintained, although it can be contained in a small package.

One year ago this month, the Perkin-Elmer Corp. offered what was described as the first commercially available CO₂ laser, a unit putting out 10 watts c-w at 5% efficiency. That model now produces 50 to 60 watts at 8% to 10% efficiency. It weighs about 100 pounds and can fit on top of a desk.

Now Raytheon is offering a commercial CO₂ laser device with an output of 500-watts c-w. Possible applications include microwelding, glass cutting and crystal cutting. Also, Coherent Radiation Inc., Palo Alto, Calif., hopes to have by this summer a folded laser with three or four tubes putting out 500 watts c-w. The company currently makes 75-watt lasers. Eugene L. Watson, the president of the new firm, says he does not plan to build sealed-off, or recirculating, systems with the present mixture of CO₂ and nitrogen, because the nitrogen tends to form undesired compounds.

The power output of sealed-off systems—although simpler in design—is about one-third that of flowing-gas systems.

Sealed-off design. The Hughes Aircraft Co. is working on both sealed and flowing-gas CO₂ lasers. One being developed under contract is described only as "a 500-hour sealed-off 10-watt laser." Hughes is also studying the feasibility of a CO₂ laser power amplifier driven by an oscillator-amplifier chain.

Company-funded work includes a search for techniques to achieve precision frequency stabilization of CO₂ lasers. A Hughes spokesman says the researchers have achieved "true single-frequency and single-transition operation" of a 1-watt CO₂ laser, with all spurious frequencies and transitions eliminated.

High-power GaAs

Gallium arsenide (GaAs) lasers are gaining in power output and efficiency, too.

Scientists at the Air Force's Cambridge Research Laboratories at Bedford, Mass., report the development of a GaAs laser with a continuous output of nearly 3 watts at an efficiency of about 15% at liquid nitrogen temperature. This is far superior to the best previous level achieved, the 1 watt at 6% efficiency reported by the International Business Machines Corp. last year.

The laser, the product of a joint effort by the Air Force lab and Boston's Northeastern University, is fabricated by diffusing zinc into n-type GaAs to form a junction 5 to 8 microns deep. This step is followed by another diffusion stage lasting two hours, during which the source is removed and the material is kept at a temperature of 1000 C. A third diffusion may be performed—this time again with a source of zinc—if a deeper junction is desired.

Solid state

Through thick and thin

For almost a year, General Instrument Corp. has been quietly producing its metal oxide semiconductor (MOS) integrated circuits with a new process that the company claims greatly reduces one of the major causes of MOS device failure—pinholes in the oxide layer that result in short circuits between interconnection crossover points.

At the same time, the process—called MROS (metal thick oxide silicon)—produces additional benefits by increasing the yield during manufacture, boosting the frequency of operation of MOS IC's by a factor of about 4 or 5, and permitting bigger, more complex circuits to be made.

Channel insulator. Pinholes are a big problem in conventional MOS technology, particularly in the more complex arrays, where the need for metal interconnections between

many devices inevitably requires crossovers. In a conventional MOS array, a thin oxide layer—typically 1,200 angstroms thick—insulates the channel areas of the devices from the metallic gate. The same oxide serves to insulate metallic interconnecting lines from the active p-regions, where required. In complex arrays, where interconnection lines must cross one another, the usual procedure is to cut a hole in the oxide and continue under the surface metallization through a conductive p-region. Pinholes in the oxide may occur during processing as a result of imperfections in the masks used for etching, causing short circuits between gates and underlying p-regions or metal interconnections and underlying conductive p-regions.

Low threshold. Simply increasing the over-all thickness of the oxide layer to reduce the incidence of pinholes is not a practical solution to the problem. The oxide must be kept thin under the gate electrode if the threshold voltage of the MOS devices is to be reasonably low. The MROS process permits the retention of a thin oxide in the gate area while producing a thick oxide over the critical crossover points. The sequence of processing steps is chosen so that the final etching time before metallization isn't long enough for mask defects to allow pinholes to form in the thick portions.

Here's how the General Instrument technique works:

First, a thin oxide layer is grown over the silicon substrate, and holes are etched in this layer to define the p-regions in the array. P-type dopants are diffused into these regions, and then a thick oxide layer—about 10 times thicker than the first—is laid over everything. The next mask defines the channel regions and areas where contact to the underlying p-regions is to be made. In these areas, the thick oxide is stripped away, and a thin oxide layer is regrown in its place. The next step is to etch through the thin oxide regions to define contact areas for the final metallization. This is the key step in MROS. Because the oxide layers over the contact area are thin, the re-

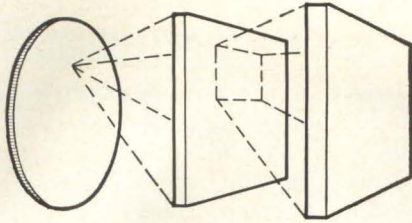

STEP 1. Wafer, MOS IC, and individual MOS FET

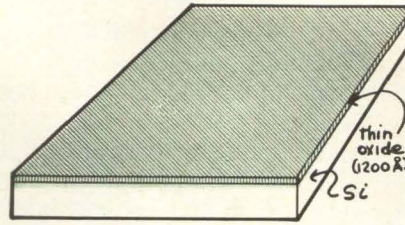

STEP 2. Oxidation of wafer (thin oxide)

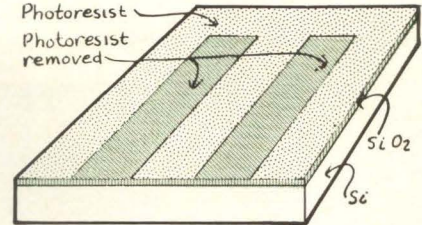

STEP 3. First mask (p-regions)

quired etching time is so short that etchant leaking through minute imperfections in the photoresist caused by a defective mask cannot penetrate completely through the thick oxide regions.

Yields increased. Even with MTOS, the channel region with its metallization over thin oxide is still subject to pinholes, according to J. Leland Seely, director of General Instrument's MOS operations, but because the over-all area consumed by contact regions in an MOS array is much greater than that occupied by the channels, the virtual elimination of pinholes in the contact areas results in a significant increase in yield. Furthermore, Seely notes, the increased thickness of the oxide layer over much of the chip area markedly reduces the parasitic capacitance between metallization and conductive p-regions, thus improving the frequency of operation of such arrays by as much as five times. Seely credits a combination of MTOS, and sophisticated circuitry with boosting the speed of General Instrument's MOS shift registers from 500 kilohertz a couple of years ago to about 2 Mhz today. Also, he says, improved yields and reliability make it possible to fabricate even bigger and more complex arrays at a reasonable cost trade-off.

The company is using the technique for all its current MOS products, including the digital differential analyzer it introduced at Wescon last summer [Electronics, Aug. 22, 1966, p. 38]. A patent for the process has been applied for, but Seely isn't sure one will be granted. He isn't too concerned, though, he says, because "we have a year's head start on the competition, and by the time they catch

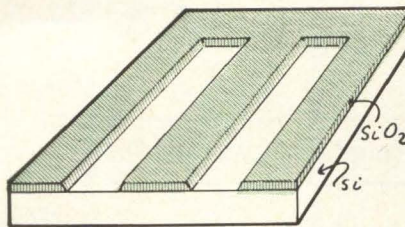

STEP 4. Oxide etched away where p-regions will be formed

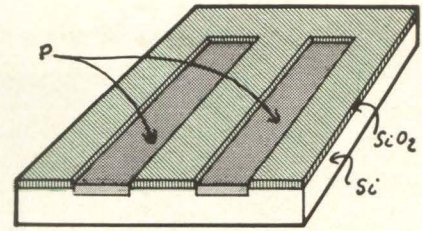

STEP 5. P-type dopant diffused through oxide cutouts

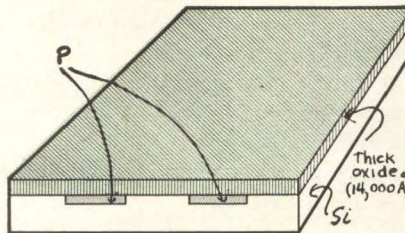

STEP 6. Thick oxide grown over entire surface

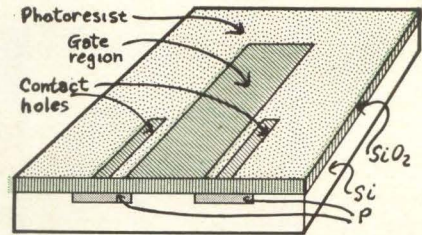

STEP 7. Second mask (gate region and contact holes)

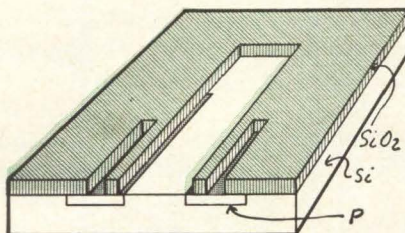

STEP 8. Oxide etched away in gate and contact hole regions

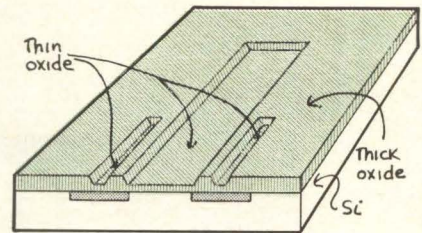

STEP 9. Thin oxide regrown in gate and contact hole areas

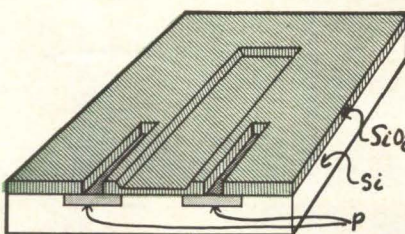

STEP 10. Third mask, contact holes cut through thin oxide

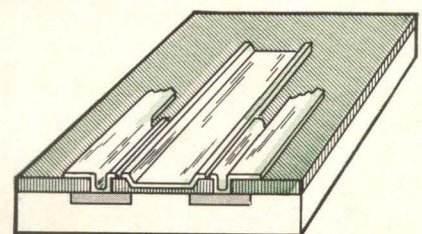

STEP 11. Fourth mask metallization pattern etched

up I expect its successor, which is well along, to be perfected.”

Components

Do-it-yourself filters

An engineer needing an active filter has two equally unattractive choices: he can design it himself or have it done by a company specializing in such work. The first choice, even with a computer to help, presents a long and difficult chore, while the second is expensive. This week, engineers will get a third choice.

Edgerton, Germeshausen & Grier Inc. of Boston is about to market a family of 10-lead miniature components that form the nucleus of an active resistive-capacitor filter and eliminate about 75% of the synthesis in a filter design. Ec&C will offer, at \$100 each, 10 units with nominal center frequencies between 100 hertz and 18 kilohertz.

The units, called Minactors, each measure 0.8 by 0.6 by 0.2 inch, with pin separations of 0.1 inch. They contain a thick-film resistor substrate, an integrated circuit amplifier and discrete capacitors for fixed-frequency operations.

Adjustable. Each of the 10 units comes with a set of curves that enables the engineer to design a complete filter operating between 70 hz and 25 khz. He need only select the component whose nominal value is closest to the desired operating frequency and read off the correct resistance and capacitance values from the design curve.

These external resistors and capacitors connect to the terminals of the component to form a tunable filter that is temperature stabilized over a wide range. Thus, the user has an immediate breadboard that can be tuned precisely.

With appropriate external circuitry, the component can be used to provide band-, low- and high-pass filters and notch filters, low-frequency f-m modulators, low-frequency sine-wave oscillators, low-frequency automatic gain con-

trols for specific frequencies, low-frequency f-m demodulators or discriminators and complex pole-zero generators for elliptic filter synthesis.

Typical operating parameters of the device are: bias supply of +12 volts d-c and -6 v d-c at 5 milliamperes each; maximum output signal of 2.5 v rms to a 10 kilohm load; short-circuit output noise of 1 millivolt rms; short circuit d-c offset of ± 100 mv; minimum available peak gain of 60 decibels.

Reliability symposium

Unsafe at any bias

Integrated-circuit manufacturers ran into a hornet's nest at the annual Symposium on Reliability that was held in Washington this month. Users and potential users made these claims:

- Integrated circuit buyers can expect to find defects in anywhere from 0.5% to more than 50% of the devices received from vendors.

- Published failure rates for ic's vary by a factor of 10,000 to 1, depending on the source of the data and how it is manipulated.

- Some reliability data provided by vendors is invented or at best speculative.

- Vendors have been known to supply performance data months before the devices themselves were available.

Dropout. Contributing to the questionable practices, said one user, is the explosive ic market. Another blamed unrealistic procurement specifications written by customers.

In a recent shipment of ic's to General Electric Co.'s light military electronics department, 60% had the wrong bar inside the case. The GE department classes itself as a medium-size customer, using about 1,000 ic's per week.

Joseph Brauer, reliability specialist at the Air Force's Rome Air Development Center, Rome, N.Y., told the conference:

“We consistently see a dual population in the microcircuit product.

One fraction behaves beautifully under the most rigorous stresses, while the other is either dead on arrival at the customer's door or fails shortly thereafter.” Between these factions are those that report a dropout rate from 0.5% to 5%.

Smoke screen. About 70% of the defects, Brauer said, are mechanical faults caused by poor workmanship. As examples he cited poor bonds, seals and metalization, and ic cases that should have been filled with dry nitrogen that were instead filled with “wet” air. Brauer concludes that the product is basically good, but that it is being handled and packaged poorly.

Manufacturers, he said, instead of assuming their proper role—that of sorting out the bad devices—sometimes hide behind a smoke screen of questionable or downright fraudulent data. They “juggle numbers to make a rather erratic or nonreproducible product appear better than it is, rather than make it as good as it can be made, or even as good as they know how, within the bounds of economic reality,” he said.

Numbers. Brauer labeled “prophetic” the numbers publicized by some vendors. The performance characteristics of products are being described “months or even years before they've been invented or put into production.”

The reliability numbers game, Brauer said, is “indicative of a mild form of insanity that has taken hold in the silicon microcircuit industry and is rapidly spreading to the rest of microelectronics.” Failure rates ranging from 0.0007% per 1,000 hours to 7.7% per 1,000 hours were cited by Brauer as representative of the numbers game.

One vendor's derating chart was questioned by Brauer. It shows, at 20% of rated power, a failure rate that increases 660 times between 25°C and 125°C, an average of more than six times per degree C. The same chart indicates a failure rate at 25°C and rated power of 1% per 1,000 hours, which differs sharply from the figure of 0.005% per 1,000 hours published elsewhere by the same vendor for the same devices “under normal use conditions.”

No nonsense. Brauer pleaded for the following industry standards to replace the meaningless numbers: device performance specifications, standards of quality, methods for reliability demonstration, rules for data reporting and manipulation and quality screening procedures that provide for more than one off-the-shelf quality level.

During the symposium, Harold Goldberg, reliability researcher for NASA's Goddard Space Flight Center, criticized vendors for "poor attitude," asserting that some would sooner tell a low-volume user like NASA to take its business elsewhere than spend time correcting a reliability fault.

Mad dog. In defense of the vendor, Dennis L. Mulcahy of General Electric's Apollo support department in Houston, said user-written procurement specifications are in many respects unreasonable and only confuse the vendor. He called for discussions between vendor and user, saying that imposing penalties on vendors for not meeting specs at this point could be like "poking a stick at a mad dog." Some testing techniques carried over from transistors are not completely legitimate, he said, citing burn-in and accelerated testing as examples.

While ic users at the conference were demanding an option of low price or higher reliability, a manager of quality assurance for one manufacturer found fault with the users.

He pinned the blame on the user's purchasing agent for buying on a price-only basis. Vendors, he said, are asked to bid on the same high-reliability order four or five times. One vendor is played against another. "Finally," he says, "I start to look for short cuts. You guys can't write the spec that I can't get around. It's either short cut or lose the business."

Pick a 2N number

James R. Greene, an expert in computer-aided design at the Collins Radio Co., told the Symposium on Reliability about a technique that overcomes one of CAD's major shortcomings—lack of adequate transistor and diode models. Greene was a key man in the team of Collins engineers that developed the technique which he says will allow CAD to be applied to more circuit problems.

Greene says there is no greater deterrent to CAD use than the need to stop and diddle with a transistor model, particularly one based on the physical phenomena in a device. Most circuit engineers are not interested in the guts of a device, he notes.

Points. The Collins model solves this problem. Curves are either obtained from the vendor or measured with a transistor curve tracer. Data points (760 per transistor) are taken from a photo of the ca-

thode-ray tube display and then punched on cards for entry onto magnetic tape.

To achieve the correct operating point for each device, a "curve read" subroutine is used. First an operating point is assumed and a solution obtained. Then device parameters are updated using the curves and the solution repeated. The process continues until the operating point changes less than a given amount, say 1%, between solutions.

The Collins program is currently limited to 30 modes and 75 elements, but can be enlarged with increased core storage. Data points for each transistor must be carefully programed, since minor inflections could result in instability of an attempted solution.

Consumer electronics

IC's sound better

Integrated circuits continue to move into high-fidelity equipment, and the reason is primarily to improve performance rather than to reduce costs.

The Heath Co., manufacturer of do-it-yourself kits, introduced this month an a-m/f-m stereo receiver with two ic's, [Electronics, Oct. 31, 1966, p. 40]. The ic's, the company says, add more to the set's performance than would be possible

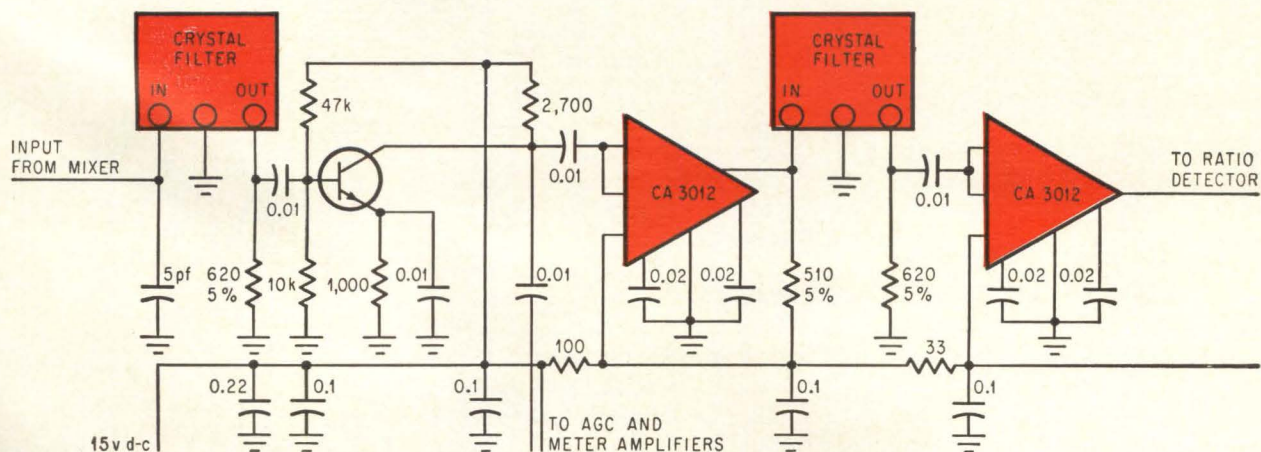

Quartz crystal filters are combined with high-gain IC amplifiers in the intermediate-frequency section of the f-m portion of Heath's a-m/f-m stereo receiver. Transistor stage following first filter is needed to drive automatic gain control and metering amplifiers. Gain of i-f stage is 120 db.

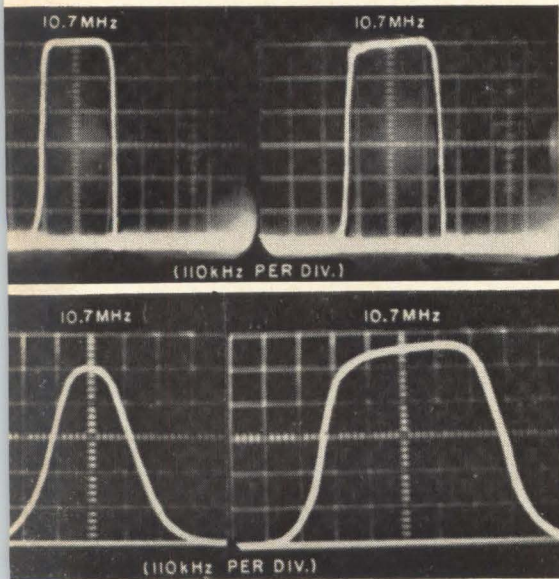

Intermediate-frequency bandpass characteristic has extremely flat top and sharp sides by comparison with that of conventional i-f strips.

with standard transistors.

Heath has combined the ic's with specially developed quartz crystal filters in the intermediate-frequency section of the f-m receiver. The result is an exceptionally square-topped bandpass characteristic with almost vertical sides.

Considering IC's, too. In using ic's, Heath joined H.H. Scott Inc. and the Fisher Radio Corp., which said last month they would put ic's into several of their models. In addition, both Harmon-Kardon Inc. and KLH Research and Development Corp. indicate they are evaluating ic's and may put them into products for the first time within a few months.

Scott is using ic's in the i-f strip of several of its f-m products—three new tuner-amplifiers [Electronics, Dec. 12, 1966, p. 26]. However, Heath, a subsidiary of Schlumberger Ltd., apparently has gone much further than Scott in redesigning the i-f strip of its top-of-the-line model, AR-15, which sells for \$330. Instead of using conventional transformer-tuned stages for selectivity, Heath has gone to two crystal filters and two ic's. The filters are supplied fixed-tuned by the manufacturer—CTS Knights Inc.—so that the amateur builder need not worry about aligning the i-f section.

Heath's ic's are RCA's CA-3012, which are wideband, high-gain amplifier limiters [Electronics, Aug. 8, 1966, pp. 133-138]. These silicon monolithic circuits, which sell for \$2.25 each in small quantities, contain 10 transistors, 7 diodes and 11 resistors. They're housed in a 10-lead, TO-5 can with a low silhouette design. Over-all gain of the i-f section is 120 decibels.

The results. The performance obtained with the ic's is spelled out by Heath as follows: capture ratio of the tuner is lowered to 1.8 db from the 3 to 4 db of many other sets. Alternate channel selectivity is 70 db and a-m rejection, because of the hard limiting in the ic's, is 50 db. Adjacent channel separation is 40 db or more at the mid-frequencies but up to 20 db at 15 khz.

The two crystal filters, which are of a four-pole lattice design, yield selectivity comparable to eight single-tuned transformer-coupled circuits, according to a CTS Knights spokesman. It's the first time such filters are being used in a commercial f-m set, he says.

The electronic touch

The marriage of keyboard instruments to electronics dates back more than 100 years, when an electric motor first replaced the choir boy who pumped air for the organ. In the subsequent years, electronics moved further into the field, replacing the organ's bulky wind pipes with tiny oscillators. Now an inventor in New Jersey, who is also a musician, has fashioned a keyboard that eliminates the moving keys.

What Paul Rosberger has developed is a keyboard whose under-surface is a dielectric material. The keyboard, or more accurately, the touchboard, operates much like the capacitor buttons on some new elevators.

Rosberger has divided the touchboard into 88 thin strips of dielectric material, with each strip representing a musical half step—say from C to C sharp—resulting in a 12-tone scale. The black keys are eliminated; hence, a player can move up the scale by half steps,

remaining on the white keys. But, if the player wants to play the conventional seven-step chromatic scale, he would have to skip certain notes.

Making the change. The keyboard has already been placed in an electric organ. The installation, explains Rosberger, is relatively simple: the old keyboard is removed, some minor interface equipment is added and the various strips are matched to the organ's sound-producing oscillators.

The inventor points out that the keyboard could also be adapted for pianos, but here the interface is much more difficult: a complex mechanism would have to be added to convert electronic signals into a mechanical motion for striking the hammers.

In designing the touchboard, one major problem arose: unless the player hit the key squarely, he was in danger of touching the key at either the left or right. To get around that, Rosberger made the active sensor beneath each key very thin, and positioned it in the center. Thus, even if the player's finger was off-center, only that note would be sounded. The key is $\frac{3}{8}$ -inch wide and the sensor $\frac{1}{16}$ -inch wide.

To orient the player, so he knows about where he is on the touchboard, Rosberger painted in black marks in a pattern that resembles the pattern for the black keys on a conventional keyboard. But in this case, of course, the arrangement is slightly different because there are 12 white keys between octaves—not seven.

Novel effects. To sound a note, a performer merely touches the metallic strip; there is no mechanical movement and therefore he can repeat a note as fast as he can oscillate his finger. Glissandos of both notes and chords can be produced without effort.

The touchboard also makes novel effects possible, such as those sounds associated with such electronic instruments as the theremin. To produce such a sound the player places two fingers on the touchboard and widens and narrows the distance between them. The fingers can also be drummed as they are moved up the board. Cluster chords

ONLY HONEYWELL OFFERS TOMORROW'S BREED OF I/C COMPUTER...



...AND THEY'RE BEING DELIVERED TODAY!

I/C construction . . . 16-bit word . . . 960 nano-second speeds . . . strong software support — unprecedented computer capability in a low cost compact. And these are only some of the features that put 3C's two new μ -COMP machines in tomorrow's computer class today.

THE DDP-516, at \$25,000, is the most advanced I/C 16-bit computer now available. Both hardware and software are already operational. Hardware includes high-speed multiply and divide (optional), a 4096-word memory (expandable to 32K), 960 nsec cycle time. The command repertoire includes 72 instructions with such capabilities as byte manipulation, skip-branch conditioning, and extensive memory reference and control.

250 field proven programs are available with every DDP-516 . . . including ASA FORTRAN IV compiler, selectable one- or two-pass assembler with a unique DESECTORIZING loader that lets you ignore memory restrictions. DDP-516 delivery: as few as 90-days.

THE DDP-416, at \$16,900, was engineered for a price/performance ratio that can't be beat by any

other on-line real-time computer. Hardware features include a 4096-word memory (expandable to 16K), 960 nsec cycle time, 1.92 μ secs add, with indirect addressing.

A 30-command repertoire, priority interrupt and power failure protection are standard. Both the DDP-516 and the DDP-416 may be mounted in standard 19" racks. Best of all, if you decide to get the more powerful DDP-516 in the future, you can continue to use your DDP-416 programs because of direct compatibility. DDP-416 delivery: second quarter of 1967.

Write today for information on both μ -COMP computers. You can't go wrong with either one. Honeywell, Computer Control Division, Old Connecticut Path, Framingham, Massachusetts.

Honeywell



**COMPUTER CONTROL
DIVISION**

can be sounded for short durations, providing a percussive sound that can be varied both in pitch and density.

Avionics

Put to the test

Navigating equipment for trans-oceanic air flights—only moderately accurate even in the best weather—faces a two-month test this summer to settle an argument over how wide the air lanes above the Atlantic should be.

The argument, between the pilots and the carriers, erupted last summer when the international airlines proposed to narrow the transatlantic lanes to 90 nautical miles from 120. The pilots immediately balked, asserting that their navigation gear wasn't accurate enough to guide them along the narrower lanes; the airlines held that the equipment was adequate but they backed down under pressure and arranged for a test.

To run the test, the airlines industry group, the International Civil Aviation Organization, is building radar stations at Gander, Newfoundland, and Kilkee, Ireland, and is arranging to have United States Coast Guard ships stationed at strategic locations in the Atlantic. Each plane in the test will be fitted with a special transponder. As the plane passes over a station, its transponder will be interrogated and will respond with a coded message that will identify it; at the same time, the station's radar will pinpoint the location of the craft to determine whether it's exactly on course.

A choice. Millions of dollars are riding on the test, scheduled to begin in July. If the trial proves the pilots right, the airlines will have two immediate choices: either maintain the wider lanes, accommodating less traffic, or scrap the present gear for a new generation of equipment, namely inertial navigation equipment.

The planes that will be watched most closely are those Pan Ameri-

can World Airways jets carrying the Sperry Rand Corp.'s inertial navigation gear, the SGN-10, the first inertial system on commercial planes.

In the future, though, inertial navigation may not have a clear field in this market. Some airline executives believe the direction should be to satellites that could provide both navigational guides and communications channels.

With an eye to this potential competition, the makers of inertial navigational gear are becoming price-conscious, hoping to sell their equipment before a satellite system becomes operational. Sperry is developing a second inertial navigator, the SGN-20, which, it says will be priced "well below" the \$100,000 charged Pan Am per unit. And General Precision Inc. is now offering a model priced at about \$80,000.

Communications

Table model

A 150-foot-diameter parabolic antenna employed mainly in highly classified antiballistic-missile work may provide the Navy with an unexpected bonus. Researchers at Randle Cliff, Md., are using the

antenna to compile a statistical table to aid in the possible use of the very high frequency transmission band (30,000 kilohertz to 300 megahertz) by communication satellites. Satellite communications are mostly conducted in the ultra-high frequency band (300 to 3,000 Mhz).

Scientists want to use the vhf band because relatively simple ground stations would be required. But first they must solve a problem: a vhf signal trying to penetrate the ionosphere hits patches of electrons that distort or weaken it.

These patches vary in intensity depending on the season and the time of day. The table would indicate the most favorable periods for vhf communications.

Computers

Teen time

The day when high school students can regularly use computers in their studies may be here soon.

The Office of Education has asked computer manufacturers and universities for bids on a study to determine the costs and feasibility of linking high schools by remote terminals to a large computer center. Time-sharing is the key to the

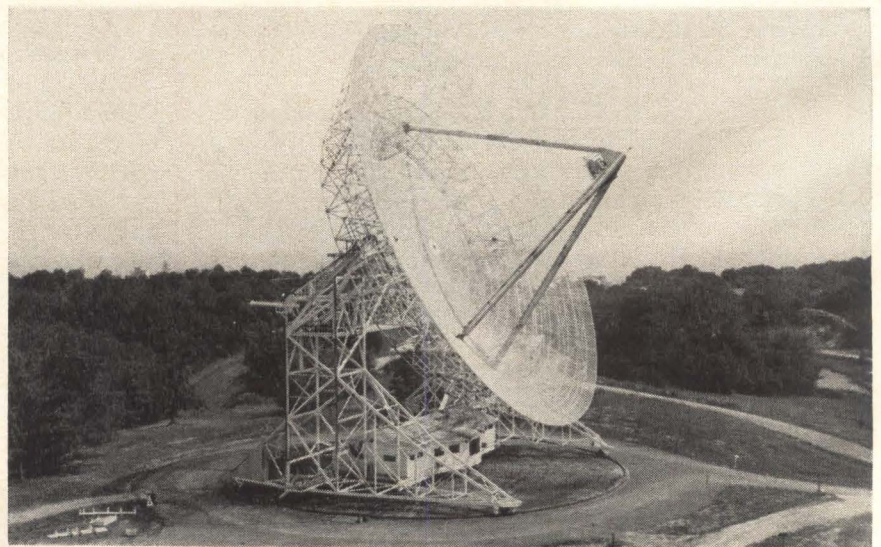

The Navy's giant antenna in Randle Cliff, Md., serves a dual purpose: it's used in antiballistic-missile work and to chart ionospheric conditions that would affect vhf signals in space-ground communications.

SPEER COMPONENT COMMENTS

How to get more satisfaction from your metal film resistors— without switching brands

It's easy. Just ask your supplier to incorporate his resistors into packaged networks or assemblies.

With pre-assembled networks, you can obtain packaging densities far greater than those obtainable with individual metal film resistors. In fact, volume savings of up to 80% can be achieved.

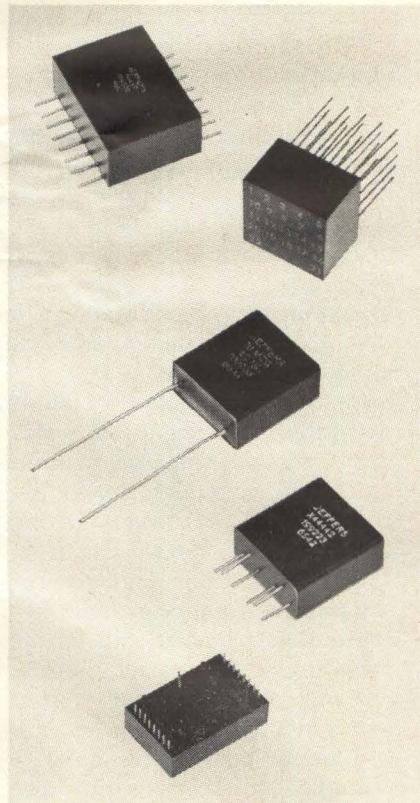

Pre-assembled and tested discrete resistor networks also offer reliability levels many magnitudes higher than those achievable with individual assemblies.

Another important advantage of networks is that manufacturing and performance cost factors can, in most cases, be surprisingly reduced.

As we noted above, these advantages (and others) will accrue no

matter what brand of metal film resistor you happen to be using. On the other hand, we would be remiss not to remind you that our Jeffers Electronics Division's JXP resistor has a definite edge over every other brand. Which means that networks incorporating this "white room" precision resistive element can really give you something extra in the way of increased satisfaction.

We therefore suggest that you don't just investigate metal film resistors networks, but that you investigate our JXP precision networks specifically. Mail us the coupon—and discover just how satisfying resistor satisfaction can be.

Please try to ignore the surplus performance that components sometimes deliver

You probably read the editorial on this subject that one of the industry magazines published not long ago. Nevertheless, the message is worth repeating:

A component designed to meet one set of specifications may also test out to more rigid specifications. And engineers have been known to cut costs by designing such a component into equipment for which it wasn't intended.

The only trouble is—they're putting themselves out on a limb (not to mention their supplier). Subsequent lots of the component may very well turn out to perform much closer to the claimed specifications—for a variety of reasons.

Speer components are among those that sometimes deliver this surplus performance. (The operative word here is "sometimes," incidentally. There are also areas in which our components always outperform their specifications. But that's another story—one we'll get into in a future issue.)

Your continued cooperation in this matter of under-specifying is much appreciated. We suspect that it's a little chilly out there on that limb.

Typical Error #8 in the testing of inductors

We're referring specifically to the testing procedures for measuring inductance and Q, as outlined in MIL-C-15305.

We heartily recommend these procedures for all commercial, industrial and military users of inductors (even users of our superb Jeffers inductors). But, as our headline suggests, there are more than a couple of commonly made test errors to watch out for.

There are eight.

Error #8, for example, consists of extreme variations in test area environment. Solution? Make sure that your measurements are made at room ambient temperature, relative humidity and pressure.

In future issues, we'll cover the other seven errors and indicate how to avoid them also.

So watch this space.

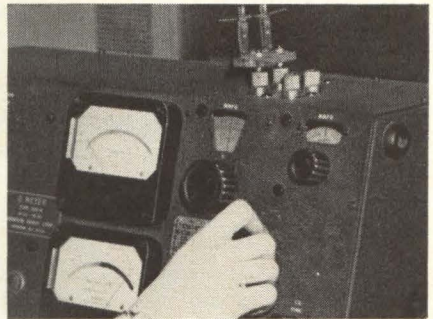

SPEER® *Speer Carbon Co.*

Speer Carbon Co. is a Division of
Air Reduction Company, Inc.
JEFFERS ELECTRONICS DIVISION
DuBois, Pennsylvania 15801

Rush complete information on your metal film resistor networks.

Name _____

Title _____

Company _____

Street _____

City _____ State _____ Zip _____

system. Bids are due on Feb. 19 and the study is expected to be completed in May or June.

Alternatives. Richard B. Otte, the project officer, says bidders have been asked to prepare two alternative designs: one involves keyboard-type consoles working on a time-sharing basis, which requires the computer to juggle many users' inputs at one time; the second uses moderately high-speed printers and readers on a multi-programming basis, permitting the computer to handle one user at a time. Both designs would provide responses in a few minutes.

Under the agency's plan, computer technology would be both a subject in itself and an aid in learning other subjects. Otte says the system will serve:

- Students studying programming and using languages such as Algol, Fortran and Cobol.
- Students using computers to work out problems in mathematics and engineering.
- School administrators preparing reports and schedules and keeping records.

Computer tutor

How can a child who can't type use a computer in a teaching program? Similarly, how can an illiterate adult learn to read with the help of a computer if he can't handle the complex input-output terminals?

Answers to these questions are being worked out by computer researchers at the Systems Development Corp. in Santa Monica, Calif., as part of a project to help people, both old and young, learn to read and write. The project involves, among other things, the development of a new kind of terminal. The input-output design is a modified Rand tablet on which an image from a computer's cathode-ray tube can be displayed in such a way that the user is able to write on it with a metal stylus, causing a new line to be "traced" on the table.

Tablet sandwich. The modified tablet consists of a half-mil Mylar sheet sandwiched between two

half-mil copper sheets. The sheets are etched into 3-mil lines on 10-mil centers, with the lines on one sheet running at 90° to the other so that they form a grid of 100 lines to the inch.

The sandwich is placed on a quarter-inch clear acrylic sheet for support, and the entire assembly is coated with clear epoxy 1 mil thick.

Even with the copper grid, the tablet is 40% transparent. Thus, by placing a crt under the tablet and projecting the tube's image through it, a person is able to see a tv picture on the tablet's surface. The crt is situated some 30 inches below the tablet and the image is projected up to the surface by an optical system.

With such an arrangement, the computer can ask a graphic question, such as: Which of the following drawings looks like a bird? The user checks the appropriate picture with the stylus. The tablet then senses the touch of the stylus on the X and Y coordinates of the copper grid and transmits the signal to the computer. The signal is subsequently fed to the crt and the check mark is projected on the tablet.

Why the effort to develop such a terminal when computer makers are already offering such equipment as Rand tablets or the less-expensive crt's with light pens?

One reason is that the light pen arrangement offers a resolution of about 10 lines per inch—too low for this application. And to have the light pen "trace" a line requires considerably more computer capability than that required for a Rand tablet. Further, the conventional Rand tablet is a difficult device for many people to operate because the imprint of the stylus produces a line not on the tablet, but on the remote crt, so the user must keep looking up from the writing surface to see what he has written.

Pencil-pusher. Systems Development is not alone in trying to produce Rand tablet modifications to sidetrack the look-up, look-down problem. The International Business Machines Corp. is working on a technique in which the user places a sheet of paper on the tab-

let and uses an ordinary pencil for a stylus [Electronics, Nov. 14, 1966, p. 43].

The Systems Development Corp. work is being directed by Morton Bernstein, a project manager for software products, and Louis Gallenson, a manager of hardware projects.

Although the system works fine in the lab, Gallenson notes that the design is not yet child-proof. "We feel that the tablet needs more protection than the 1-mil epoxy provides," he says. "I can just visualize some six-year-old using the table as a dart board."

Second thought

The software problems plaguing the manufacturers of some large-scale computers have been neatly sidestepped by a small Santa Ana, Calif., company that is using two old ideas in a new way.

The Standard Computer Corp. has combined emulation—hardware modification—with an interpretive program—software. Standard Computer's ic 6000 has two distinct read-write memories: one contains the main program, written to run on any other computer, and the other is a smaller and faster memory containing a special interpretive program. The interpretive program looks at each individual instruction in the main program and generates one or more corresponding instructions in a form that the ic 6000 can use.

Slow but good. An interpretive program is usually loaded into the computer's memory with the main program. It is a slow, inefficient way to get a computer to handle a program meant to be executed on a different kind of computer. For example, "multiply 42 by 25" might be interpreted for a computer with no multiply instruction as "add 42 to itself 24 times."

Emulation usually involves the temporary physical modification of a computer. It is somewhat faster than interpreting, but is still inefficient. For example, the standard read-only memories on International Business Machines Corp.'s System 360 computers can be re-

RCA announces 40429 and 40430 6A TRIACS

- With high gate sensitivity
- With symmetrical triggering characteristics ($I_{GT}=25$ mA max)
- With surge current protection up to 80A
- and the price on the 40429 is only..... **\$1.50***

RCA 40429
controls 720 watts
at 120 volts
($V_{BOM} = 200$ V).
* \$1.50 each
in quantities of
1,000 and up.

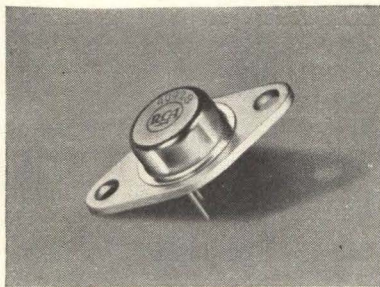

RCA 40430
controls 1440 watts
at 240 volts
($V_{BOM} = 400$ V).
\$1.98 each
in quantities of
1,000 and up.

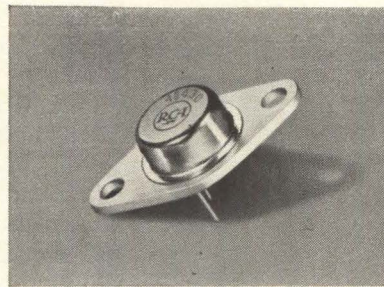

RCA brings you a new generation of control devices! Each of these 6-amp Triacs can provide the same full-wave function as *two* SCRs... with the option of using either positive or negative gate-trigger signals. Hermetically sealed in an all-welded TO-66 package, RCA 40429 and 40430 can simplify your control circuits... reduce costs... add reliability and efficiency.

Evaluate these new RCA Triacs for AC motor controls, heat controls, universal motors, dc power supplies, or solenoid or relay controls. They could very well be the key to next year's model improvements.

For complete information including price and delivery, contact your RCA Field Representative. For technical data,

write RCA Electronic Components and Devices, Commercial Engineering, Section IN1-4, Harrison, N. J. 07029.

CHECK YOUR RCA DISTRIBUTOR FOR HIS PRICE AND DELIVERY

GATE FIRING CHARACTERISTICS								
Quadrant	I +		I -		III +		III -	
	typ.	max.	typ.	max.	typ.	max.	typ.	max.
mA @ 25°C	10	25	20	25	20	25	10	25



RCA ELECTRONIC COMPONENTS AND DEVICES

The Most Trusted Name in Electronics

**"Just building
a lipstick size
relay that worked
would have
been easy."**

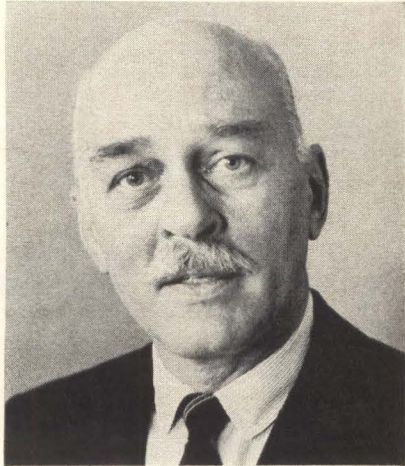

**Building one
around our
great high-rel
idea was
another story."**

Wedge-action*, our great high-rel idea, is 9 years old. Our 2PDT lipstick-case size relay has been around for less than 2 years. But it's already a standard replacement for the competition in lots of MIL-R-5757/8 applications.



Why? Because it outperforms every spec requirement for both high and low-level loads. Like all our wedge-action relays, it combines long contact wipe with high contact force to give you continually clean precious-metal mating surfaces throughout life. Competitively priced with fast delivery.

The lipstick is just one of our family of wedge-action relays, which cover almost every dry-circuit to 2 amp application. When you need a high-rel relay that really works, test one of ours and try your darndest to prove we're wrong. You won't be able to.

* U.S. Patent No. 2,866,046 and others pending.



Electro-Tec Corp.

SLIP RINGS • RELAYS • SWITCHES • OPTICS

P. O. Box 667 • Ormond Beach, Florida
(904) 677-1771 • TWX 810-657-0305

Manufacturing Facilities:
Ormond Beach, Fla. • Blacksburg, Va.

Electronics Review

placed with special ones that permit the 360 to run old IBM 1401 programs. The modified 360's run more slowly than the unmodified version, but they run at least as fast as the 1401.

The IC 6000 currently can interpret binary programs written for the IBM 7094 and for the IBM 7044, and an interpreter is being prepared to run IBM 7010 decimal programs. The 7094 programs run about one-third to one-fourth as fast as they would on the original machine.

Space electronics

Keeping in touch

Losing contact with a manned spacecraft while control is "handed" from one earth station to the next has long bothered space officials. Planners in NASA's office of tracking and data acquisition set out last year to define a system to plug these gaps. They now are confident that continuous communications with a manned spacecraft in low earth orbit can be achieved using three or four satellites in synchronous orbits to relay voice and data signals.

The Astro-Electronics division of the Radio Corp. of America, Princeton, N.J., and the Research and Development division of the Lockheed Missiles & Space Co., Sunnyvale, Calif., are scheduled to finish feasibility studies on such a data relay satellite system next month. The Pentagon is watching the work closely, hoping it can be applied to its satellite communications programs.

"These would not be simple satellites," says Paul Barritt, NASA program manager for data relay satellites. Each would weigh between 1,000 and 5,000 pounds.

Space link. The satellite system would provide a voice and data relay from a manned spacecraft orbiting at up to 1,000 nautical miles, and serve as a link with a manned or unmanned vehicle during the low-altitude phases of lunar and

planetary flights.

Barritt says the greatest benefit from the system would be voice communication with a vehicle in trouble. He's sufficiently satisfied with RCA's and Lockheed's progress to say that the technology for such a system is essentially in hand. Some hardware for the satellite will be tested on an Applications Technology Satellite due for flight in 1968 or mid-1969. He adds, however, that going to the next step after the current studies—project definition—looks bleak because of NASA's budget constraints.

Despite the lack of funds in fiscal 1968, Barritt believes that a system could be operational by 1972 with a "reasonable, relaxed development schedule"—provided the program is funded in fiscal 1969.

Barritt's guess is that the relay system would cost between \$100 million and \$150 million to develop and deploy. He estimates it would cost about \$35 million a year to operate, paring about half from the cost of operating the space agency's network of ground stations, ships and aircraft for manned space flights. The relay system, upon deployment, would immediately render obsolete the eight KC-135 Apollo range instrumentation aircraft, which now cost \$6 million a year to operate. These planes have no tracking function, serving strictly in the data relay role.

Save money. The eight Apollo range instrumentation ships would be eliminated if the proposed relay system demonstrates a reasonable tracking capability. These vessels represent \$20 million in annual operating costs.

Although the RCA and Lockheed study contracts do not encompass detailed tracking considerations, NASA wants the proposed satellites to have a pseudo-random range code and a doppler ranging system that is compatible with the capability of the unified S-band system.

The relay satellite must be able to handle voice and data communications from two manned spacecraft simultaneously. Each may have two transmitters and two receivers. Transmissions from the spacecraft will be either:

Discover the widest range of gold-plated specialty wire available.

From thick to thin. So thin, in fact, it has to be weighed to be measured.

We start with the highest-quality base stock, draw and then plate it with a bright, ductile, temperature-resistant 24K gold. The deposit is 99.5% pure. Its porosity is minimal. Its solderability is excellent. And it's resistant to discoloration. If that's not enough, our specially designed electroplating equipment and rigid quality control give a completely uniform plating

around the wire—and from spool to spool.

We have a total capability to produce practically anything you want. Deposits from 5 to 200 millionths of an inch in thickness can be plated on almost any temper or diameter specialty wire or ribbon to your specification.

If you'd like to see what we can do with wire or ribbon, send for a sample today. Write: Sylvania Electric Products Inc., Parts Division, Warren, Pennsylvania 16365.

SYLVANIA
SUBSIDIARY OF
GENERAL TELEPHONE & ELECTRONICS **GTE**



Exclusive!

Single Dial Source and Detector



Simultaneous Tuning of Source and Detector with New Wayne Kerr SR268 (100kHz - 100MHz)

With other systems, it is necessary to tune the source to a specific frequency and then the detector must be tuned to the exact same frequency.

The new Wayne Kerr SR268 Source & Detector performs both functions *simultaneously* in a *single* operation over the range 100kHz-100MHz at a short-term frequency stability of 0.01%. Frequency accuracy over this range is $\pm 2\%$.

The simplicity of operation provided by ganged tuning is furthered by the incorporation of common-mode rejection transformers in the input and output networks, reducing any interference or cross-talk from unwanted signals.

Operable simultaneously from an external nine-volt battery and a six-volt battery for pilot light indications, SR268 is ideal for field work, too. SR268 is an ideal companion instrument to Wayne Kerr R. F. Bridge B601, VHF Bridge B801B and precision R. F. Bridge B201.

SPECIFICATIONS

Frequency Range:	100kHz to 100MHz in 9 bands:
BAND 1	100kHz - 216kHz
BAND 2	216kHz - 465kHz
BAND 3	465kHz - 1000kHz
BAND 4	1.00MHz - 2.16MHz
BAND 5	2.16MHz - 4.65MHz
BAND 6	4.65MHz - 10.0MHz
BAND 7	10.0MHz - 21.6MHz
BAND 8	21.6MHz - 46.5MHz
BAND 9	46.5MHz - 100MHz

Oscillator Output Level:

Maximum output into 75 Ω : BANDS 1-7, 2V rms; BAND 8, 1V rms; BAND 9, 0.5V rms

Output Level Control: 39dB in 3dB Steps (75 Ω)

Detector Sensitivity:

Maximum Input Required for 10% Meter Reflection: BANDS 1-6, 1 μ V x (fMHz)^{1/2}; BANDS 7-8, 10 μ V; BAND 9, 30 μ V 46.5MHz - 70MHz, 20 μ V 70MHz - 90MHz, 10 μ V 90MHz - 100MHz
Input Level Control: 4 Steps of 20dB (nominal)

For literature and detailed specifications, write:



Wayne Kerr CORPORATION

18B Frink St., Montclair, N. J. 07042 • Phone (201) 745-2438

INNOVATIONS IN INSTRUMENTATION

Electronics Review

▪ Frequency-division multiplex/frequency-modulated, with a maximum multiplexed base video bandwidth of 1.5 megahertz and a maximum peak deviation for the multiplexed signal of 3.5 Mhz, or,

▪ Pulse-code modulated/phase-modulated, with a maximum data rate of a million bits per second and a bit error rate of one per second.

Each target may transmit in one of these modes or both. Although antenna design is not part of the studies, it was assumed that the target vehicle would have a small directional antenna with a maximum gain of 20 decibels for video and an omnidirectional antenna for voice and data transmissions at a power level of 20 watts. The omnidirectional antenna would have a gain of 26 db, necessitating an antenna gain on the relay satellite of 40 db or more for the voice and data links.

A relay satellite in effect would act as a frequency translating repeater. Communications from the orbiting spacecraft to the relay satellite would be in the S band and in the X band from relay satellite to the ground. The links from the relay satellite to the ground would have about one-tenth the capacity of the links between the spacecraft and relay satellite.

Antenna plans. NASA planners think the relay antenna might be one of two types: a space-erectable dish with a 30-foot aperture or a multiple-beam phased array. Barritt says the dish would be lighter and that the technology for it is further advanced than for the phased array. He hints that he likes the phased-array concept.

The array, if it is selected, would account for 60% of the relay satellite's weight. There might be from 500 to 2,000 elements, with associated electronics weighing roughly 3 pounds per element.

If a phased array is used, according to Barritt, stabilization would probably be by gravity gradient, possibly augmented by gas jets. The 30-foot dish would probably require "totally active" stabilization. If the dish could be steered electronically, a combination of gravity gradient and rotating wheels might be possible.

Investing in a Sweep Generator with a limited frequency range can be an expensive purchase unless you're positive your requirements won't change 6 months or a year later. To avoid that embarrassing possibility, Telonic's SM-2000 is built for non-obsolence; it is actually

20 SWEEP GENERATORS

in one. The chassis will accept 20 different plug-in oscillators spanning various segments of the spectrum from 20 Hz to 3000 MHz, in an area that just fits your application today, or tomorrow, or in 6 months, or next year. And since it doesn't cost any more than most single-range units, why not be a hero. Order one.



BASIC SPECIFICATIONS*

Frequency Range	20 Hz to 3000 MHz
Impedance	50 or 75 ohms
Operating Modes	Sweep, CW, 1 kHz Modulated Sweep or CW
Attenuation	0-60 dB in 1 dB steps
Output (Scope Horizontal)	15 volts P-P (approx.)
Frequency Markers	8 Plug-in and/or Variable
Sweep Width, Sweep Rate, Level Control, and Flatness will depend on the Plug-in Oscillator used.	

*Complete specifications on the SM-2000 and Plug-in Oscillators, plus an extensive treatment of Sweep Frequency Measurement Applications are covered in Catalog #70. Yours on request.

Telonic INSTRUMENTS
Division of Telonic Industries Inc.

50 N. FIRST AVE., BEECH GROVE, INDIANA 46107, TEL. (317) 787-3231 TWX-810-341-3202

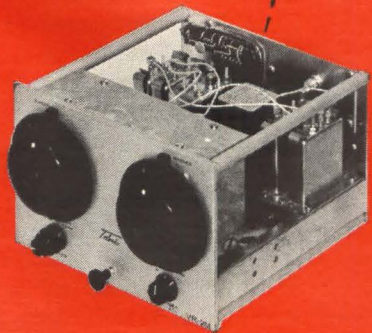

CONVERT COMPUTER DATA TO TV DISPLAY WITH THE ELECTROSTORE®

This TV Display shows a high resolution alphanumeric presentation derived from

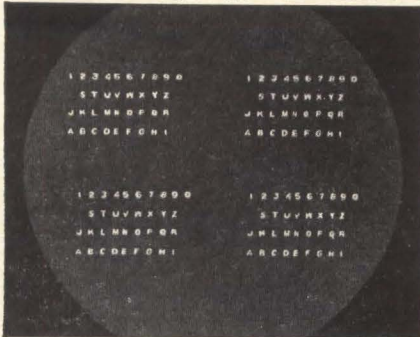

a computer. It is only one example of a computer display using the Electrostore, Model 221.

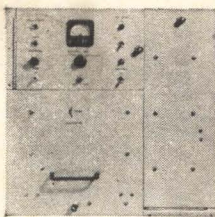

Model 221 Electrostore
single-gun storage tube
Input/Output Response
10 MHz or 20 MHz
Input Amplitude
Required 0.7 volts to
2.0 volts p-p
Deflection Amplitude
5 volts p-p
Deflection Response
DC to 800 KHz
Programmer Optional

The Model 221 scan-converter utilizes a cathode-ray recording storage tube. Input video signals and deflection information are applied to the tube through various amplifiers and control circuitry. Data is stored within the tube in the form of a raster, circular, or spiral scan. This information can be read off periodically through appropriate amplifiers without destroying the stored data. The input can be up-dated periodically and the stored information erased partially or in its entirety. By introducing the proper signals, the Electrostore can convert a variety of formats to TV display, i.e. computer-to-TV, radar-to-TV, IR-to-TV, or sonar-to-TV.

Write for technical memos and application notes covering the Electrostore.



223 Crescent Street
Waltham, Mass. 02154
Tel. (617) 894-8200

Electronics Review

For the record

Supply and demand. Texas Instruments Incorporated has announced a 40% price increase on three families of diode transistor logic integrated circuits. The devices affected are SN14246, SN14346 and SN14346N. The Sprague Electric Co. also increased its prices on hermetically sealed metal-cased solid tantalum capacitors.

Automation. The Sun Oil Co. will install a direct digital control computer in a plant producing petrochemicals and gasoline components in Marcus Hook, Pa. The computer system was produced by the Foxboro Co.

Milestone. Honeywell Inc. has chalked up worldwide 1966 sales of \$910 million—up 24% over 1965. James H. Binger, board chairman, said the company's fastest growing area is the computer business. He added that Honeywell passed a milestone in 1966 when its domestic computer operation became profitable.

Approval. The Federal Communications Commission has authorized the Communications Satellite Corp. to buy the satellite ground station at Andover, Maine, from the American Telephone & Telegraph Co.

Lights out. Mosaic Fabrications Inc., a subsidiary of the Bendix Corp., has developed a fiber optics system that tells motorists if outside lights are working. Glass fibers are stretched from each of the car's light bulbs to a dashboard panel. The fibers pick up light from the bulb and pipe it to the panel where it shows as a pinpoint of light. When a bulb burns out, the driver can spot it at a glance.

Capital issues. President Johnson proposed several programs in his State of the Union message that will have an impact on the electronics industry. One was a ban on wiretapping and electronic bugging and snooping. A second was a plan to help states and cities combat crime by speeding communications and installing special alarm systems and other electron-

ics equipment. A third would put in motion a major clean-air program calling for equipment to monitor and reduce air pollution. Yet another would use computers to prevent massive power failures.

Replacement. The American Stock Exchange will put a new computer complex in operation in March. The system will use two GE 415 computers to handle the tasks currently performed by three IBM 1401 units.

Healthy. The Western Electronic Manufacturers Association predicts a 12% sales increase for the electronic industry in the West this year. The 1967 forecast projects sales of over \$5.7 billion by companies in the 13 western states. This forecast compares with the gain of 18.5% that was achieved in 1966.

Mergers. Agreement in principle was reached for Teledyne Inc. to acquire the Brown Engineering Co. and for Mensor Inc. to merge with LTV ElectroSystems Inc. The Automatic Sprinkler Corp. of America has acquired Electronic Security Inc.

Prices. The prices of several key materials rose. The Phelps Dodge Corp. raised its price for copper from 36 to 38 cents a pound. Cobalt prices were increased by 20 cents a pound at mill level and Kennametal Inc. boosted by about 10% the base metal price for special tungsten carbide shapes.

Awards. The IEEE will present to Charles H. Townes of the Massachusetts Institute of Technology its principal award—the medal of honor—for his work on masers and lasers. The medal has been awarded 47 times since its creation in 1917. Major annual awards will go to George H. Brown of the Radio Corp. of America for his work in antennas, electromagnetic propagation, broadcasting, radio frequency heating and color tv; Harvey Fletcher, formerly of Bell Telephone Laboratories, for his work with acoustics; Warren P. Mason, formerly of Bell Labs, for his work in sonics, ultrasonics and electromechanical transducers, and John R. Whinnery of the University of California for his teaching, administration and textbooks.

Stackpole commercial resistors helped Wurlitzer engineers discover a new harmony in four parts.....

quality, price, delivery and service.



Only strict attention to detail produces a fine musical instrument. That's why Wurlitzer engineers so carefully select each component that goes into Wurlitzer Organs. Stackpole commercial resistors help make these magnificent instruments electronic, as well as musical, marvels. Performance in tune with your most demanding needs is the Stackpole guarantee. Write: Stackpole Carbon Company, Electronic Components Division, Kane, Pa. 16735.

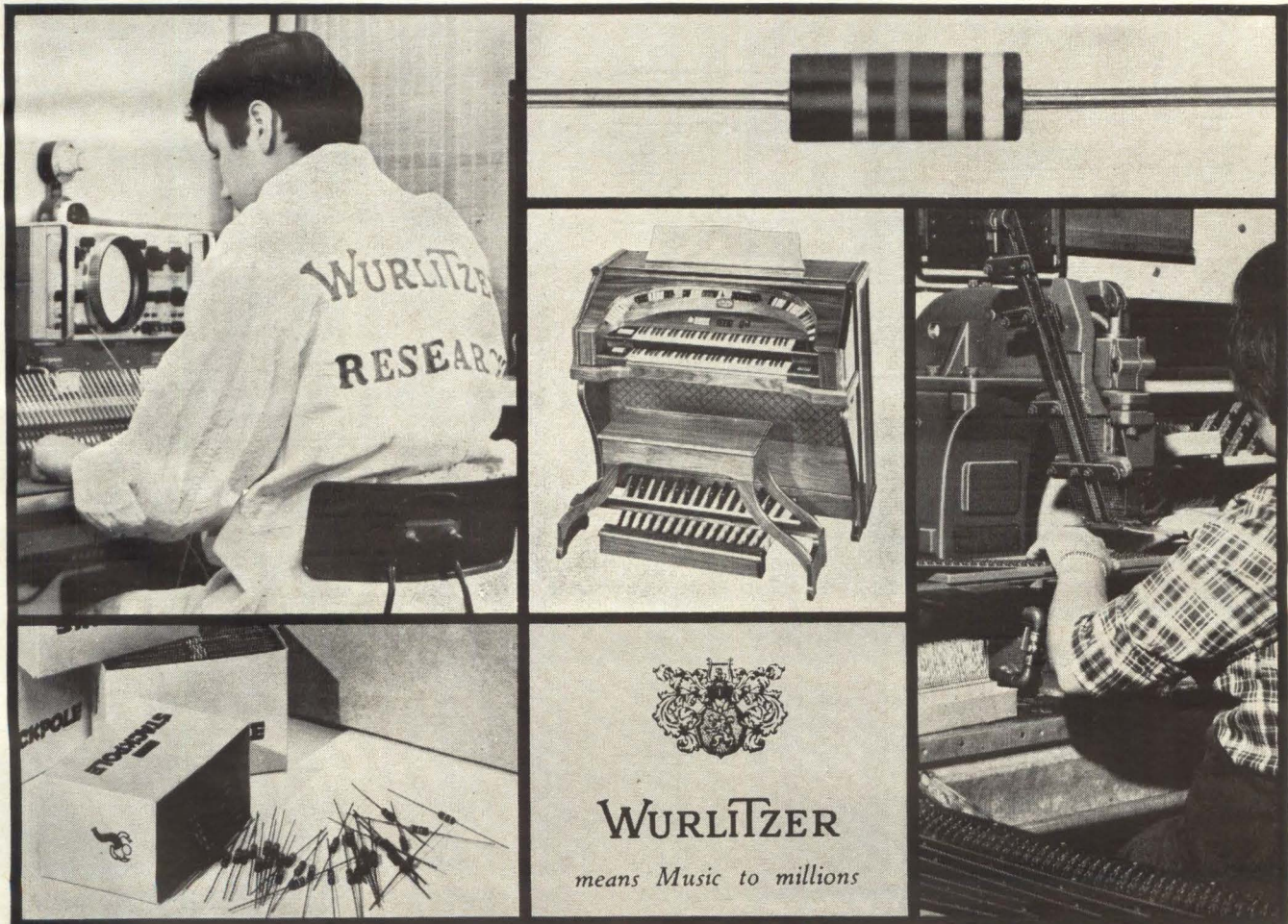

State of the monolithic art

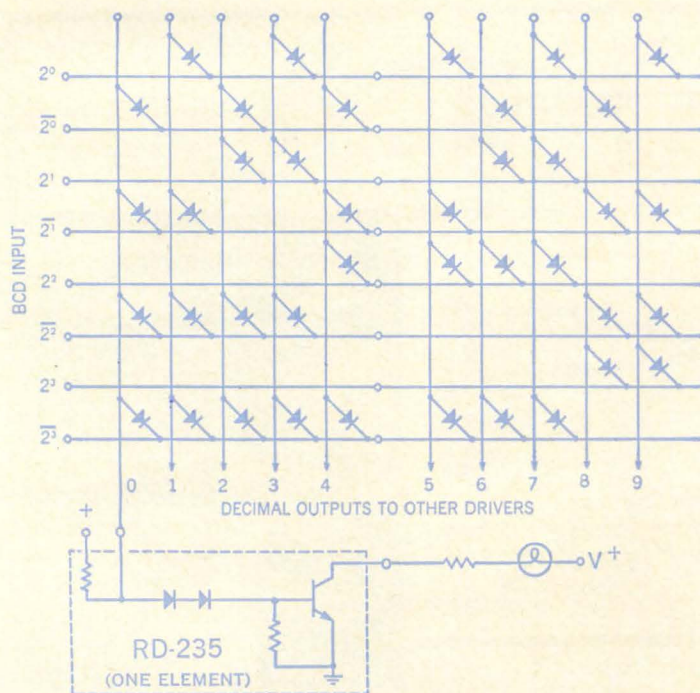

New flexibility
in design of BCD
decode networks with
Radiation's 8 x 5
Monolithic
Diode Matrices

Radiation's RM-17 Monolithic Diode Matrix, in conjunction with the RD-235 Hex High Voltage Interface Driver, offers a simplified approach to the design of BCD decode networks for driving decimal indicators. Other integrated BCD decoders are limited to only one weighted binary code. However, Radiation Matrices can be "customized" to any weighted binary code to decimal conversion. This design flexibility is achieved through Radiation's fusing technique for selecting desired coding patterns.

The 8·4·2·1 BCD decoder, shown at left, is only one example of the many possible matrix patterns which can be formed. Only two Radiation 8 x 5 Matrices are used in this application.

TRUTH TABLE

2^0	0	1	0	1	0	1	0	1	0	1
2^1	0	0	1	1	0	0	1	1	0	0
2^2	0	0	0	0	1	1	1	1	0	0
2^3	0	0	0	0	0	0	0	0	1	1
Decimal output	0	1	2	3	4	5	6	7	8	9

Note: True logic positive. Only one output will be true at any one time.

State of the design art

Radiation's popular dielectrically isolated matrices provide an unusual degree of flexibility. (1) RM-17 Matrices contain 40 active devices per chip. (2) A fusible link in series with each diode permits unlimited matrix patterns to be formed. And (3), circuits can be combined to produce an almost infinite variety of size configurations.

In addition to flexibility, Radiation 8 x 5 Matrices offer the increased reliability of monolithic construction. Size and weight requirements are slashed through reduced package count. Further, cost of matching, testing and assembly of discrete diodes is eliminated.

Production has been expanded to guarantee fast shipment of ma-

trices "customized" to your exact requirements. In fact, most orders are shipped on a 24-hour basis.

A new low-cost RM-114 design in a ceramic dual in-line package is available in volume at a unit price of \$4.00—and can be supplied to any code configuration requested.

Write for data sheets on the entire line of Radiation Monolithic Diode Matrices. *Worst-case limits* are included, as well as all information required by design engineers. We'll also be glad to supply our new manual, Monolithic Diode Matrix Technical Information and Applications. For your copy, request publication number RDM-T01/A01 from our Melbourne, Florida office.

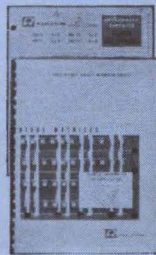
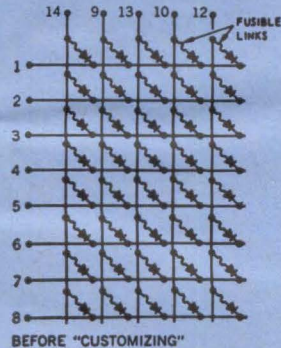

Radiation 8 x 5 Monolithic Diode Matrices* (typical limits)

Characteristic	Symbol	RM-17	RM-19	RM-14 RM-114†	Unit	Test conditions (T _A = +25°C)
Forward drop	V _F	1.0 0.7	1.3 0.75	1.0 0.7	V	I _F = 20 mA I _R = 1 mA
Reverse breakdown	BV _R	60	60	50	V	I _R = 100 μA
Reverse current	I _R	7	25	70	nA	V _R = 25 V
Reverse recovery	t _{rr}	7	11	30	ns	I _F = 10 mA to I _R = 10 mA
Crosspoint capacitance	C _{cp}	1.9	1.9	2.0	pF	V _R = 5 V; f = 1 MHz
Coupling coefficient	I _{CL}	20	20	20	μA	See data sheet

*Supplied in T0-84 packages. †Supplied in ceramic dual in-line package.

All Radiation integrated circuits are dielectrically isolated.



**RADIATION
INCORPORATED**
MICROELECTRONICS DIVISION

Sales offices: Suite 622, 650 North Sepulveda Blvd., El Segundo, Calif. (213) 772-6371—Suite 232, 600 Old Country Road, Garden City, N. Y. (516) 747-3730—Suite 201, 1725 Eye Street, N. W., Washington, D. C. (202) 337-4914—P.O. Box 37, Dept. E-01, Melbourne, Florida (305) 723-1511, ext. 554

Radiation also offers a new line of Operational Amplifiers which open the door for integration of systems requiring high performance analog circuitry. These amplifiers are designed to provide the ideal 6 dB per octave high frequency roll-off required for unconditional stability in operational feedback connections *without* use of external compensation . . . even in the critical unity gain configuration. Three types are immediately available in T0-84 flat packages: general-purpose, broadband, and high-gain circuits.

Use of Radiation's RA-240 IC Amplifier, for example, permits design of high Q active filters with high initial attenuation. The amplifier has an extremely high internal feedback impedance, and allows wide flexibility in the choice of external filter components without regard to the active element of the circuit.

Typical characteristics:

Q = 100 (symmetrical response)

f_o = 10 kHz

E_{out} = + 10.8 V to -4.8 V

Initial attenuation ≈ 40 dB per decade.

Final attenuation ≈ 20 dB per decade below unity gain.

For further information, refer to our ELECTRONIC DESIGN advertisement of January 4. Write for data sheets on our entire line of operational amplifiers. *Worst-case limits* are included, as well as all necessary design information. We'll also be glad to send a copy of our new manual, Operational Amplifier Technical Information and Applications, ROA-T01/A01. Contact our Melbourne, Florida office.

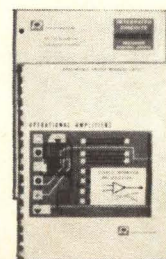

Circle 55 on reader service card

RESOLVER/SYNCHRO DIGITAL CONVERSION

A very short course for engineers who are concerned with converting resolver or synchro data to digits and vice versa.

Engineers working in digital computer input/output interface systems for tactical airborne equipment, aircraft and space vehicle simulation, antenna positioning or programming, and similar systems are increasingly involved in solving the digital/analog interface problem for resolver and synchro data. Accomplishing this task becomes quite simple by taking advantage of North Atlantic's family of high accuracy resolver/synchro converters. Through the use of solid-state switching and precision transformer techniques, these converters provide single-speed accuracy and resolution from 10 to 17 bits, along with solid-state reliability and calibration-free operation.

Resolver/Synchro-To-Digital Conversion

One typical North Atlantic resolver/synchro interface is the Automatic Angle Position Indicator (Figure 1), which converts angular data from both 400Hz resolvers and synchros to digits.

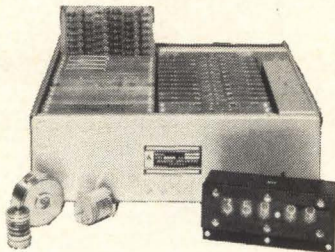

Figure 1. Model 5450 Automatic Angle Position Indicator converts resolver and synchro angles to digital form.

This device uses all solid-state plug-in cards and trigonometric transformer elements (no motors, gears or relays), and operates at all line-to-line voltages from 9 to 115 volts. It can be supplied in a wide range of configurations for specific system requirements, for example, signal frequencies 60Hz to 10KHz, binary or BCD outputs, .001° resolution with 10 arc second

accuracy, and multi-speed and/or multiplexed inputs. Its five-digit Nixie readout can be integral or remote.

The unit illustrated has an accuracy of .01°, and two basic modes of operation. They are read-on command (rapid acquisition) and tracking (least significant bit update). Prices start at \$5900.

Digital-To-Resolver/Synchro Conversion

North Atlantic's all solid-state digital-to-resolver/synchro converters (Figure 2) accept digital input data at computer speeds in either binary angle or binary sine/cosine form and convert to either resolver or synchro data. Their high accuracy and resolution (up to 17 bits) and freedom from switching transients meets an important requirement in space-mission simulation and antenna positioning systems for smooth servo performance at low rates of data change. All models are usually supplied with input storage registers.

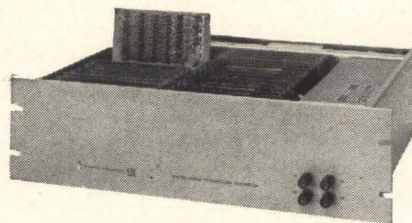

Figure 2. Series 536 Digital-To-Resolver Converters translate binary digital angle to four-wire resolver data.

Depending on the combination of features specified, prices are in the \$4500. to \$6000. range.

Modular D-R/S Converters For High-Density Systems

The plug-in converters pictured in Figure 3 were developed by North Atlantic specifically for airborne systems and for aircraft simulation systems requiring high-den-

sity multi-channel operation. The modules illustrated provide 11-bit digital-to-synchro conversion and are capable of driving up to four torque receivers. As with other North Atlantic resolver/synchro interfaces, conversion is achieved through solid-state switching and trigonometric transformers, so there are none of the stability or calibration problems associated with conventional resistor-chain/amplifier type converters. Prices, in production quantities, run about \$1100. per set. In prototype quantities about \$1500. a set.

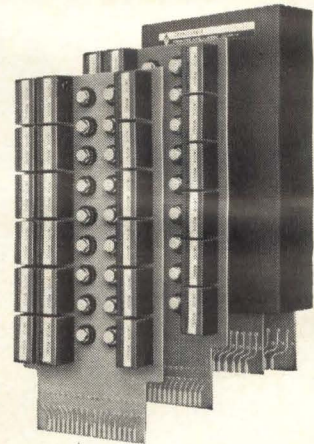

Figure 3. Series 537 D/S Converter Modules can drive multiple torque receivers from 11-bit digital data.

If you would like to take advantage of North Atlantic's state-of-art experience in resolver/synchro computer interface, we would be pleased to show you how these converters can meet your particular requirements. Or if you prefer, we will arrange a comprehensive technical seminar for your project group, without cost, in your own plant. Simply write: North Atlantic Industries, Inc., 200 Terminal Drive, Plainview, N.Y. 11803. TWX 510-221-1879. / Phone 516-681-8600.





**WHAT'S AN ELECTRONIC
SPECIALIST DOING IN THE
SCREEN PRINTING BUSINESS?**

...PRINTED CIRCUITRY, OF COURSE!

Now, in addition to knowing about capacitors, diodes and resistors, you're supposed to know all about film, resolution, exposure and wash-out! . . . Cheer up!

Ulano doesn't know beans about microelectronics . . . but we know all there is to know about screen printing! We should. We've been at it for over 30 years. We're the world's leading manufacturer of screen stencil film . . . *any kind.*

. . . There's a right Ulano film for every project.

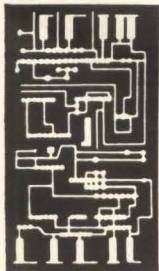

*In screen processing
of complex printed circuitry...
there's no margin for error!
That's why Ulano offers
a complete line of
Screen Process Stencil Films
especially designed for
the Electronics Industry.*

ulano ^{T.M.}

610 DEAN STREET, BROOKLYN, N.Y. 11238

NEW YORK • CALIFORNIA • CHICAGO • ZURICH

In Europe: ULANO A. G., Untere Heslibachstrasse 22, Kusnacht 8700, Switzerland

Write on your letterhead for special electronic test kit (no charge) No. 5948.

Circle 57 on reader service card



From David—to Goliath...
 (5 watts) (250 watts)

Dale RH Wirewounds have BONUS capacity to handle any power or stability problem.

Dale's RH Wirewound line offers 6 models, 5 to 250 watts. Each has bonus ability to dissipate heat beyond MIL-R-18546D requirements—see chart. In addition, you get an extra bonus of exceptional stability when RH models are derated to mil levels. To achieve this bonus performance, Dale combines precision wirewound elements with specially-conductive extruded aluminum housings and special molding compounds. The result is exceptional heat transfer ability matched by no other housed wirewound line.

NEW HIGH-REL MODELS

The ARH, a high-rel version of the RH, is now available in four models: 5, 10, 15 and 30 watts. ARH resistors meet the requirements of MIL-R-39009 and are being produced on the same line as Dale's ARS and AGS—the world's most reliable wirewounds.

For complete housed resistor information including non-inductive and thru-chassis models—write for Catalog A.

RH RESISTOR SPECIFICATIONS					
DALE TYPE	EQUIV. MIL. TYPE	DALE RATING*	MIL. RATING	RESISTANCE RANGE (OHMS)	STANDARD HEAT SINK
RH-5	RE-60	7.5 (5)	5	.1–24K	4x6x2x.040
RH-10	RE-65	12.5 (10)	10	.1–47K	Aluminum Chassis
RH-25	RE-70	25	20	.1–95K	5x7x2x.040 Aluminum Chassis
RH-50	RE-75	50	30	.1–273K	12x12x.059 Aluminum Panel
RH-100	RE-77	100	75	.1–50K	12x12x.125
RH-250	RE-80	250	120	.1–75K	Aluminum Panel

ELECTRICAL & ENVIRONMENTAL SPECIFICATIONS

Tolerance: .05%, .10%, .25%, .5%, 1%, 3%

Load Life: 1% max. ΔR (RH-5 – 50) 3% max. ΔR (RH-100 – 250) in 1000-hour load life.

Operating Temp: –55° C to +275° C

Overload: \pm .5% max. ΔR per MIL-R-18546D

*Power Rating based on 275° C max. internal hotspot temperature with resistor mounted on standard heat sink. Figures in parentheses indicate wattage printed on RH-5 and RH-10. New construction allows higher ratings as shown, but these resistors will be printed with the higher rating only on customer request.



DALE ELECTRONICS, INC.
 1300 28th Avenue, Columbus, Nebraska
 In Canada: Dale Electronics, Canada, Ltd.



Washington Newsletter

January 23, 1967

Hughes wins order for tactical comsat, may get another

After lengthy negotiations, the Air Force has awarded the Hughes Aircraft Co. the contract to design and build a tactical communications satellite [Electronics, Dec. 12, 1966, p. 74]. General Electric Co. was runner-up in the bidding. **Hughes has received \$9 million to begin work on the fixed-price, incentive-fee contract, which has a target price of \$23,505,076.** The goal is to demonstrate the feasibility of using space repeaters for the armed services' tactical communications. The satellite is expected to be launched next year from the Eastern Test Range into a stationary orbit 22,300 miles above the equator. Even if successful, it wouldn't be used to handle communications with forces in Vietnam, but would be available for emergency use.

Hughes may also win an order for a military communications satellite for Britain. The firm reportedly leads the Philco-Ford Corp. and TRW Inc. in the bidding for the award. The U.S. Air Force will put the satellite into synchronous orbit over the Indian Ocean and then turn it over to the British, who will pay the \$20 million total cost of the project. Operation of the satellite is scheduled to begin in March 1968. The British will use the craft for 24-hour communications with Australia and points in Southeast Asia.

Air Force slates TX road show

The Air Force will try the "hard sell" approach in an effort to gain supporters for its Testing Extra (TX) semiconductor reliability program. **Air Force reliability officials plan to conduct what they call a road show to explain TX benefits.** On the tour schedule: the heads of the procurement commands and logistics commands, and possibly user companies and international groups such as the North Atlantic Treaty Organization.

If TX is widely accepted, the Air Force insists, users will get more reliability for their money. Army and Navy reliability officials are cool to the idea, contending that the new specification is unnecessary [Electronics, Jan. 9, 1967, p. 43]. Among other things, TX calls for 100% burn-in testing.

Communications for commuters

Commuters on the rapid-transit systems of the 1970's may be able to read teletyped news and make calls over videophones during their ride. At least, the prospects for equipping future high-speed systems with a variety of communications gear are being studied by the Environmental Science Services Administration.

Three transmitting methods are being considered by the agency's telecommunications group in Boulder, Colo.: inductive coupling in the 20-to-200 kilohertz range now employed on railroads; capacitive coupling utilizing a plate on the ground and one on the car with a half-inch air gap; and wave-guide coupling using a "leaky" wave guide radiating only toward the train in the millimeter and centimeter wavelengths.

Defense budget put at \$70 billion plus

President Johnson is telling businessmen in private meetings that the fiscal 1968 military budget, to be released this week, **will run between \$70 billion and \$75 billion and will maintain the U.S. effort in Vietnam at least at current levels.**

Washington Newsletter

NASA studies 6-in-1 satellite

A multipurpose satellite to perform the tasks of as many as six different special-purpose satellites is being considered by the National Aeronautics and Space Administration. The craft's jobs would include those already being done by satellites in earth orbit, such as communications, meteorology and geodesy, as well as those still in the planning stage—navigation, traffic control and earth resources surveying. NASA engineers are currently writing a work statement for an upcoming study of the Unified Space Application Satellite, but haven't yet decided whether to study the complex craft in-house or farm it out to industry. NASA planners believe that a single satellite could be designed to do the multiple tasks, but the study must determine whether a single optimum altitude and orbit inclination can be decided upon.

Program to spread R&D funds starts

The Defense Department has started the ball rolling on a program to spread its research and development funds more evenly among the nation's colleges and universities. Geographic imbalance in Pentagon R&D spending is being increasingly attacked by Congressmen representing "have-not" areas.

The new program is a start, but the amount of money slated for it isn't enough, according to Democratic Sen. Fred Harris, who comes from the have-not state of Oklahoma; he will resume Congressional hearings this spring on the economic impact of Government research.

The Pentagon will spend \$20.5 million on the program in fiscal 1967 and is seeking \$27 million for fiscal 1968. It is asking schools to submit proposals for work in such areas as laser technology, terrain-avoidance systems, automatic navigation gear, and computer networks.

Voyager planners reaffirm schedule

Despite earlier worries that the Voyager unmanned planetary exploration program would be delayed because of money problems [Electronics, Oct. 17, 1966, p. 49], NASA believes it can still make the first launch to Mars in 1973 with the \$69 million it is seeking for the project in the fiscal 1968 budget. In fact, program managers believe they could settle for \$50 million and still make the 1973 date.

Slated for release soon is the agency's request for bids to design the Voyager capsule; two or three companies will be selected to compete. The builders of the mother spacecraft will be selected from among the Boeing Co., the General Electric Co. and TRW, Inc.

Nike X decision again deferred

President Johnson has again deferred a decision on deployment of the Nike X antiballistic-missile system, and the consensus in Washington is that none will be forthcoming while efforts to reach new disarmament agreements with the Russians go on. However, the debate will continue. Some Republicans are already talking about a missile-defense gap, and a number of Congressmen want work to at least proceed on tooling up for Nike X production.

Addenda

International Business Machines Corp.'s Federal Systems division has submitted an unsolicited proposal to the Agency for International Development to study the cost and benefits of using satellites to beam educational television to developing nations.

UGON RELAYS

SMALL SENSITIVE SPEEDY

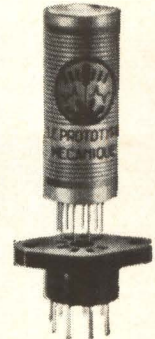
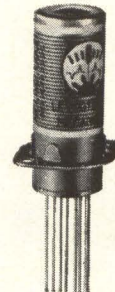

SIZE The larger relays shown here (actual size) occupy about 2 cubic centimeters; the smallest one shown occupies one cubic centimeter.

SENSITIVITY Standard subminiature relays operate on 5 milliwatts; smallest one operates on 30 milliwatts; relays set up for operation at higher drive power give greater resistance to shock and vibration and faster response.

SPEED Normally, response is 5 milliseconds or less; relays can be driven to as short a response as 0.1 millisecond.

CONTACTS SPDT with your choice of three contact materials to give you maximum life at your operating load —
below 1 ma; up to 1V for light loads
1 to 150 ma; up to 24V dc (medium)
100 to 500 ma; 50V ac or dc max.

ISOLATION 10,000 megohms minimum and 1 pf maximum between fixed contacts and all parts of relay; 10,000 megohms minimum and 7 pf maximum from moving contact to coil.

For electrometers, a special relay with the normally open contact brought out through header in top gives you 50,000,000 megohms minimum to any other part of relay.

COIL Your choice of 15 standard resistances in the subminiature size from 20 to 14,500 ohms (higher on special order); 7 standard resistances to 8,000 ohms in microminiature size.

ENVIRONMENT Temperature limits as wide as -40°C to $+125^{\circ}\text{C}$ for most types.

Shock and vibration high because of magnetic and mechanical balance of moving contact; in rugged relay with 90 milliwatt coil drive as much as 80 g for sinusoidal vibration from 0 to 2000 Hz, 150 g for sine pulse shocks of 8 milliseconds duration.

All relays hermetically sealed with glass-bead insulators for operation in any humidity; cadmium-plated steel cases for fungus protection.

CATALOG Yours for the asking.



CAMBRIDGE DIVISION
Phone 301-228-4600
TWX 710-865-9655
CAMBRIDGE
MARYLAND
21613
U.S.A.

Tomorrow's answers... through Sperry Research

Pseudo-random dot scan image of aircraft is displayed on narrow-band TV system.

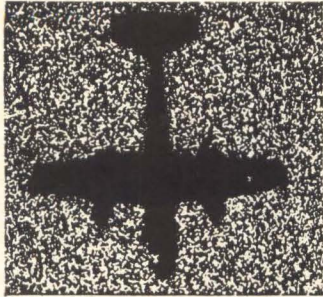

THE LIMITS OF UNDERSTANDING —

How much can displayed information be condensed and still be intelligible? How much detail is necessary to identify a TV image? To understand speech? Sperry is experimenting in all these areas. A pseudo-random scanning technique, for example, has demonstrated that simple shapes can be identified on a television screen at bandwidths as narrow as a kilocycle. In speech processing, methods are being developed for encoding and decoding speech to reduce bandwidth while retaining good understandability, speaker recognition, and certain esthetic qualities present in normal speech. These techniques will permit the transmission of many, high quality simultaneous conversations over a single voice channel. In visual psychology, research is attempting to correlate electrical waveforms generated in the human brain with present theories of depth perception.

□ These are just a few of the many scientific achievements of Sperry Rand Research Center. Sperry can help you meet similar short- or long-term technological objectives through basic and applied research in a variety of scientific disciplines. Our scientists are currently engaged in intensive investigation and experimentation in the following areas:

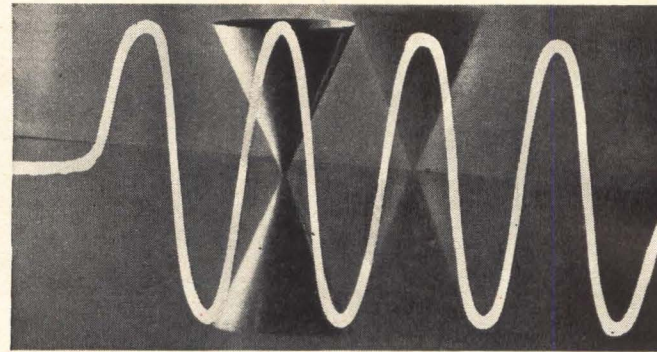

The broadband response of a biconical antenna above a ground plane is studied by driving the element with 4 rf cycles at the rate of 1.3 GHz. The radiating element is simulated by placing a cone above orthogonal reflecting surfaces.

RANGING IN —

Through a better understanding of the wideband properties of microwave networks and the use of new pulse compression techniques, Sperry scientists foresee order-of-magnitude improvements in radar range resolution. Their achievements point the way to true imaging in battlefield surveillance and satellite identification radars as well as more accurate determination of target trajectory and greater clutter suppression. Other projects in the works include the synthesis of new components such as microwave pulse compression filters, and the generation of microwave phase-coherent energy for use as a diagnostic tool in antenna transient studies.

SYSTEMS RESEARCH

Radar sciences
Human factors
Applied mathematics and control theory
Data processing techniques
Underwater communications and sonar

PLASMA PHYSICS

Microwave and optical devices
Re-entry plasmas
Energy conversion

SIGNAL SUCCESS —

Real headway in signal design and processing is being made at the Center. New techniques — coherent and incoherent — have been found for achieving sub-clutter and sub-jamming visibility. Sophisticated computer search is aiding the discovery of radar waveforms that are both practical and effective. Other aspects of modern radar theory currently under study include phased array radars, sequential detection techniques, and video schemes such as pulse width discrimination and side lobe blanking.

ATMOSPHERIC PHYSICS

Environmental modeling
Active and passive radiometry
Laser atmospheric probing

SOLID STATE SCIENCES

Microelectronics
Microwave and optical signal processing
Microwave oscillators
Thin film techniques
Laser materials and techniques
Crystal chemistry
Magnetic phenomena

State-space concepts afford the basic tool for practical design optimization of submarine control systems.

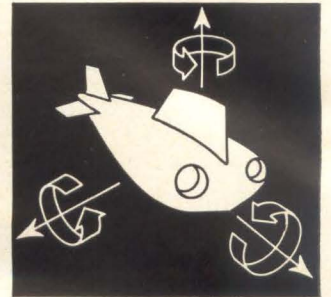

IN DEEP WATER —

Sperry is conducting work in a variety of disciplines which, taken together, form an integrated capability in undersea electronic and acoustic technology. For example, investigation of underwater acoustic channels is aimed at achieving major improvements in communication between submarines and between submarines and surface ships. New navigation and control techniques for deep submersible vehicles will minimize fuel consumption during the performance of specific maneuvers. Human factors research is devoted to the critical area of man-machine compatibility such as in the design and use of displays.

SPERRY

DIVISION OF
SPERRY RAND
CORPORATION

SPERRY RAND RESEARCH CENTER • Sudbury, Massachusetts 01776

BRIEF SPECIFICATIONS: Power rating—2 Watts ■ Working Voltage—500Vdc ■ Resistance Range—50 ohms to 10 megohms linear, 250 ohms to 5 megohms tapered ■ Available with shaft seals, mounting seals, switches, high torque, ganging, non-metallic shafts, L & T Pads, concentric shafts, high-voltage standoffs, backlash assemblies, encapsulated units and locking bushings ■ Meets specifications of MIL-R-94—Style RV-4.

when you're being critical
the design and the

SERIES 53

Hardness of contact
optimum compatibility

low noise and long life. Backlash is zero. Total enclosure protects against moisture and other environmental hazards. No matter how critical your application—computer, space, military systems, etc.—you can count on the Series 53 potentiometer because you know it's by

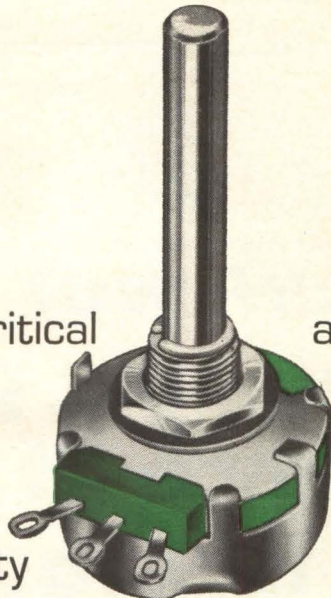

about quality, nothing matches
construction reliability of our

POTENTIOMETER

materials are selected for
to assure minimum wear,

low noise and long life. Backlash is zero. Total enclosure protects against moisture and other environmental hazards. No matter how critical your application—computer, space, military systems, etc.—you can count on the Series 53 potentiometer because you know it's by

CLAROSTAT

CLAROSTAT MFG. CO., INC. DOVER, NEW HAMPSHIRE

small



smaller



smallest



G.E.'s new wet slug tantalum capacitor gives you the performance of the CL64 in only 1/2 the case size

Get the highest volt-microfarad product per unit weight and volume of any capacitor you can buy with General Electric's new 69F900 wet slug tantalum capacitor. How? General Electric reduced the case size of the military type (CL64) wet slugs by 1/2 (it's even smaller when compared to solids). Electrical characteristics and performance remain essentially the same. G.E.'s new 69F900 answers the need for a commercial wet slug capacitor with the high volumetric efficiency demanded by modern high density applications.

G.E.'s new addition to its complete line of tantalum wet slug capacitors has excellent high capacitance retention at low temperatures and can be

RATING	CASE SIZE	VOLUME
50V, 30μf		
solid (CS12)	.341 x .750	100%
wet slug (CL64)	.281 x .681	58%
69F900	.145 x .600	15%
15V, 80μf		
solid (CS12)	.341 x .750	100%
wet slug (CL64)	.281 x .681	58%
69F900	.145 x .600	15%
6V, 180μf		
solid (CS12)	.279 x .650	100%
wet slug (CL64)	.281 x .641	100%
69F900	.145 x .600	25%

stored to -65°C. Its wide operating range is -55°C to +85°C. And it meets the parameters of larger military wet slugs: vibration to 2000 Hz, 15g acceleration!

The new sub-miniature 69F900 capacitor is fully insulated and has a low, stable leakage current. Voltage ratings are available from 6-60 volts; capacitance ranges from 3.3-450 microfarads.

Choose from a complete line of G-E wet slug tantalum capacitors to fill your slim, trim circuit needs. Write for GEA-8369 for details about the 69F900 and the other capacitors in General Electric's complete wet slug tantalum line, or ask your G-E sales engineer. **Capacitor Department, Irmo, South Carolina.**

ELECTRONIC COMPONENTS DIVISION

GENERAL ELECTRIC



430-28A

**WHO'S
IN
CHARGE
OF THE
PULSES
AROUND
HERE?**

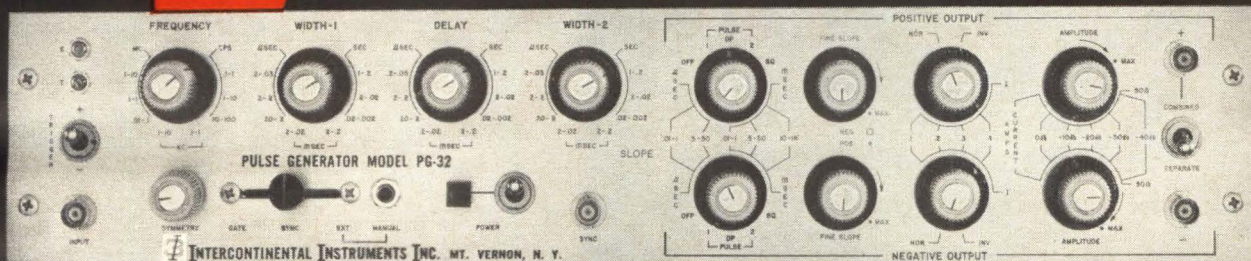
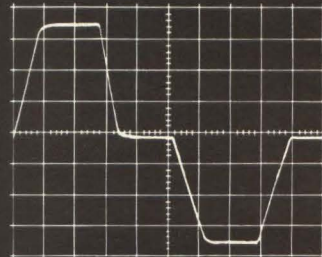
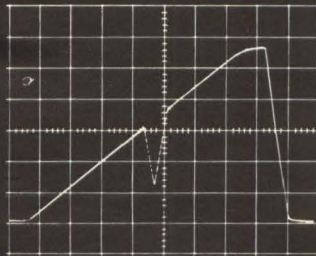
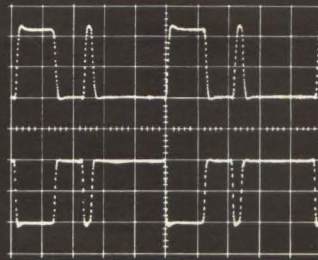

YOU ARE.

One of the nice things about the 3-1 Model PG-32 Dual Channel Pulse Generator is that it keeps things in perspective. If you don't care for what its output waveshape is, you can change it — it doesn't limit your usage.

You can control continuously the repetition rate, amplitude, rise time, fall time, pulse width, delay and so on of either or both of its dual output channels. If you want a current source, it's a current source at 500 ohms minimum impedance (current up to 400mA). When voltage is the thing, it's a voltage source ($\pm 20\text{mV}$ to $\pm 20\text{V}$ from 50 ohms). Want bipolar outputs? Combine the channels and, voila!, bipolar outputs. The complement of the normal output of either chan-

nel? Easy. Throw a switch. Since both output channels are completely DC-coupled, any combination of waveforms is possible . . . including 100% duty cycle.

From each channel you can get single or double pulses; either first or second pulse. Or square waves. Plus sync pulse. You can externally trigger or gate the PG-32 to 10MHz. One-shot? Pushbutton. DC offsets to 10V via front panel controls.

All (silicon) solid-state; 3½" high; modest price. If you would like technical literature or a demonstration, please write or 'phone.

Model PG-32. From Intercontinental Instruments, Inc. . . . an affiliate of CHRONETICS.



Intercontinental Instruments Incorporated

An Affiliate of Chronetics

U.S.A.: 500 Nuber Avenue, Mt. Vernon, New York (914) 699-4400 TWX 710 560 0014
Europe: 39 Rue Rothschild, Geneva, Switzerland (022) 31 81 80 TELEX 22266

We don't think the film pots we made to someone else's requirements are good enough for you.



That's why Litton never has any off-the-shelf potentiometers.

Yet we make some of the most versatile precision film pots in the industry. Linear. Trigonometric. Logarithmic. Pressure-altitude. Impact-mach. Nonlinear empirical. And every one of them custom engineered to fit your specific requirements.

Litton conductive film pots can be provided readily in any mechanical angle—sector configurations or continuous rotation. In addition, they feature

- Infinite resolution
- Terminal conformity as low as $\pm 0.01\%$ depending upon size, resistance, and type of function
- A minimum temperature coefficient of $-250 \text{ PPM}/^\circ\text{C}$
- An ambient temperature range to $+150^\circ\text{C}$
- Matching resistors and switches when specified
- Gold-plated slip rings and precious metal contacts to prevent oxidation, reduce noise and slip-ring wear
- Dimensionally stable housings to withstand shock and vibration, heat and cold, dust and humidity.

And *each* one is microscopically inspected, tested at every stage of production. What's more, our government-certified testing equipment allows simultaneous exposure to environmental extremes.

Send us your requirements or applications. We'll handle them—fast—at no cost or obligation. For more information, write or call: Litton Industries, Potentiometer Division, 226 East Third Street, Mt. Vernon, N.Y. 10550. Tel.: (914) 664-7733 TWX: (914) 699-4687 • Western Regional Office: Tel.: (213) 273-7015.

LITTON INDUSTRIES 
POTENTIOMETER DIVISION

Reliability and price levels for every ER application



C } Hermetic seal — 50 PPM
S } .001% Failure Rate

H } Molded — 50 PPM
R } .01% Failure Rate

K } Molded — 100 PPM
M } 1% Failure Rate

Mepco, using MIL-R-55182 rev. C as a base, now makes metal film resistors available in three reliability and cost levels to meet your specific application.

- C/S in Mepco's FH series hermetic seal metal film resistors . . . for applications requiring the highest level of reliability and absolute protection against the most stringent environmental conditions.
- H/R in Mepco's FE series molded metal film resistors . . . for use where true hermetic sealing is not critical.
- K/M in Mepco's FE series molded metal film resistors . . . where economy can be achieved for ER applications.

Let us show you how this product line can fit into your program. Write or call today for Bulletin FE.

Mepco, Inc., Columbia Road, Morristown, N.J. 07960
(201) 539-2000, TWX (201) 538-6709



A Heritage of Reliability



Are you
listening?

Mallory Capacitor Company chooses GAF x-ray film to make sure everyone gets the word

Computers, telemetry, AC/DC converters, navigational gear, radar and other sensitive electronic components used in our space and missile programs rely on tantalum capacitors for long life and dependable communications.

Mallory Capacitor Company, manufacturer of these tantalum capacitors, relies on GAF Industrial 'H-D' x-ray film to detect inclusions, excess bonding material, and check casing element clearances on all electrical connections.

To quote Mr. John E. Beckley, Quality Control Supervisor, "Only Industrial 'H-D' is used to radiograph our capacitors. It's the one x-ray film

producing the definition, sensitivity and contrast that reveals minute detail within tiny components."

Ultra-fine grain and very high contrast characteristics make Industrial 'H-D' film the ultimate for pinpoint radiographic examination. Your distributor of GAF x-ray products can supply you with information on our complete line of films and chemistry.

GAF maintains a nationwide staff of full-time Industrial X-ray Specialists—trained to render expert radiographic counsel, assistance and service. We have one in your area. Don't hesitate to call on him.

E-123



GENERAL ANILINE & FILM CORPORATION

140 WEST 51 STREET, NEW YORK, NEW YORK 10020

If we made only digital IC's, what would we try to sell you?

If we made only linear IC's, what would we try to sell you?

If we made only hybrid IC's, what would we try to sell you?

If we made only MOS devices, what would we try to sell you?

If we made only transistors, what would we try to sell you?

But since we make **all** these, what will we try to sell you?

Only what you need.

Philco has the broadest line of products in the microelectronics industry. We make everything from epoxy transistors to MOS IC's, and we can show you how to use all these products to your advantage. Because our capability is the most diversified in the industry, we make an excellent source for all your present—and future—systems requirements. We offer you economy, unbiased service, and the finest products available today. Here are a few examples of Philco's broad capability.

DTL: We make both SE and the 930-Series standard DTL families. Our E-line 930 Series in dual inline packages guarantees the same levels of fan-out and noise immunity over 0° to 75°C available in hermetically-sealed packages.

Super RTL: For high-speed, medium-power logic systems. Typical propagation delay of 8 ns per logic level and power dissipation of 3.5 mW per gate.

Milliwatt III: For high-speed, low-power, applications. Typical propagation delay of 13 ns per logic level and power dissipation of 3 mW per gate.

Linear: PA 7600 RF/IF video amplifier, with highest gain

bandwidth available today. PA 7601 RF/IF bandpass amplifier, with medium gain and bandpass of 40 to 150 MHz. PA 7602 utility amplifier, high gain, for use in analog guidance, computer, and instrumentation.

Hybrid: Compatible hybrid circuits; PNP, NPN, FET, and MOS FET—all on the same substrate. Packaged in: epoxy for industrial uses; low-cost conformal for consumer products; hermetically-sealed in TO-5 or flat packs for reliability optimization.

Transistors: PNP and NPN planar and planar epitaxial silicon transistors.

Picologic (Large-scale Integration): Integrated MOS subsystems include the pL4000 Series (gates, counters, etc.) at speeds from DC to 100 Kc and the pL5R shift register series with speeds from 10 Kc to 1 Mc.

Call or write: **Philco-Ford Corporation Microelectronics Division**
Sales Offices: 2920 San Ysidro Way, Santa Clara, California (408-245-2966) / 999 North Sepulveda, El Segundo, California (213-772-6226) / Northwest Industrial Park, Second Ave., Burlington, Mass. (617-272-1600) / Benson Manor, Suite 114B, Washington Lane, Jenkintown, Pa. (215-885-0430) / 1215 Drew Street, Clearwater, Florida (813-446-0124) / 815 Connecticut Avenue, N. W., Washington, D. C. (202-298-7810) / Suite 208, 700-108th St., N. E., Bellevue, Wash. (206-454-5061) / New York, N. Y. (212-244-1373).



PHILCO-FORD CORPORATION
Microelectronics Division
Santa Clara, California • 95051

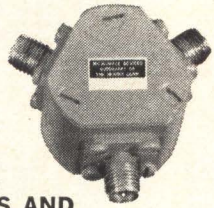

CIRCULATORS AND ISOLATORS

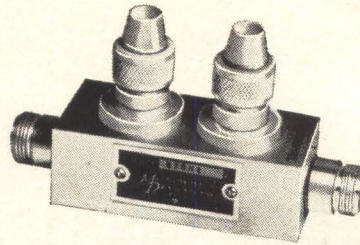

DIRECTIONAL COUPLERS AND HYBRIDS



RF FILTERS AND WAVEMETERS

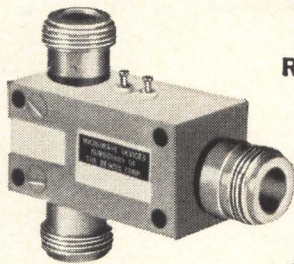

RF COAXIAL SWITCHES



RF WATTMETERS

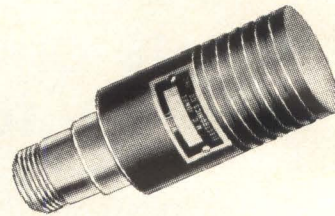

DUMMY LOADS AND TERMINATIONS

Only one supplier gives you in-depth selection in these basic types of microwave devices.

In fact, only one makes all 6 types.

Only Bendix offers you such a comprehensive line of microwave components and instruments. And many are stocked for off-the-shelf delivery. That includes the 6 basic product categories—as well as such other microwave devices as adapters and transitions, integrated devices, attenuators, miniature components, and phase shifters. In all, *over 5,000* different models.

Need a special device? We're equipped to modify or build a device to meet your specific needs.

You'll see what we mean by in-depth selection when you scan our new catalog. Write, call or TWX: Microwave Devices, Inc., Farmington Industrial Park, Farmington, Conn. 06032. Phone: (203) 677-9771; TWX: (710) 432-2206.

Microwave Devices, Inc.



Testing integrated circuits is a key step in their production. At the Molecular Electronics Division of Westinghouse Electric Corporation, Tally perforators are used to log data as each module is run through a series of parameter checks. Data logged on the tape is then analyzed by computer.

According to W. DeLauder, Foreman of the Instrumentation Section at Westinghouse, the five Tally Model 420 perforators worked extremely well

during a fifteen month period just ended. Fewer than eight calls per perforator were made to keep all five perforators on duty over the entire period. The average time per call was 2.23 hours with an average cost for parts of \$3.05.

During the fifteen month period, the five perforators punched with precision over 478 miles of tape. There are a lot of good solid engineering reasons why Tally perforators are extraordi-

narily reliable. For all of them, please address Ken Crawford, Tally Corporation, 1310 Mercer Street, Seattle, Washington 98109. In the U. K. and Europe, address Tally Europe, Ltd., Radnor House, 1272 London Road, London, S. W. 16, England.

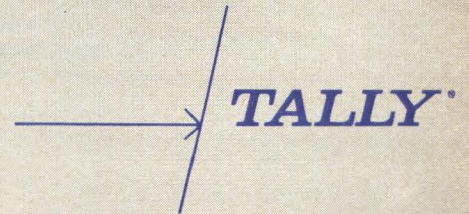

**There are five hard working
Tally perforators on the job
around the clock at Westinghouse.
During one 15 month period, these
perforators were ready for work
99.9% of the time...and work they
did, knocking perfect chad out of
2,520,000 feet of tape!**

How's that for reliability?

*Here is the latest Westinghouse integrated circuit test console
with a new Tally P-120 Perforator which turns out twice the work of the Tally 420.*

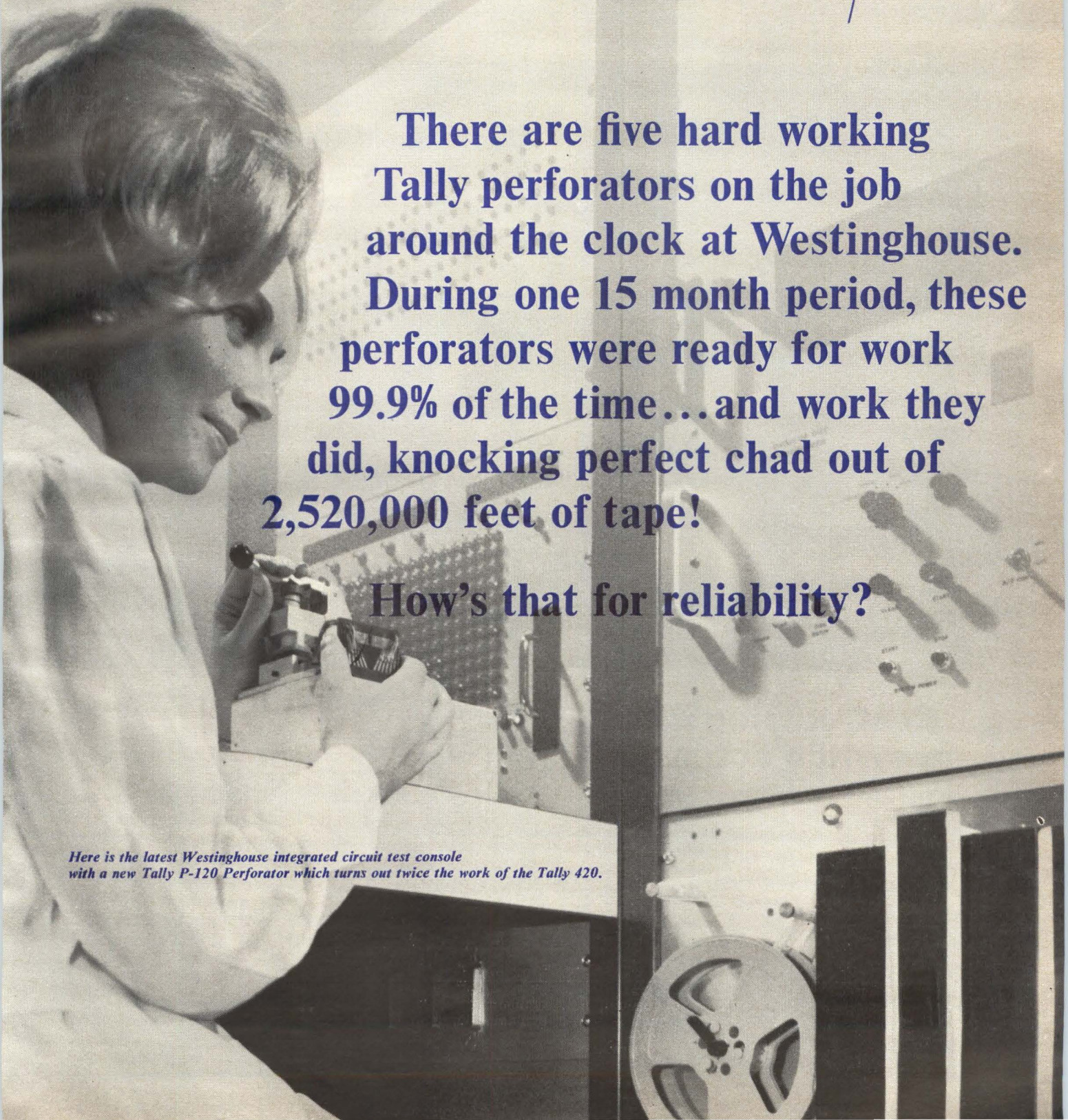

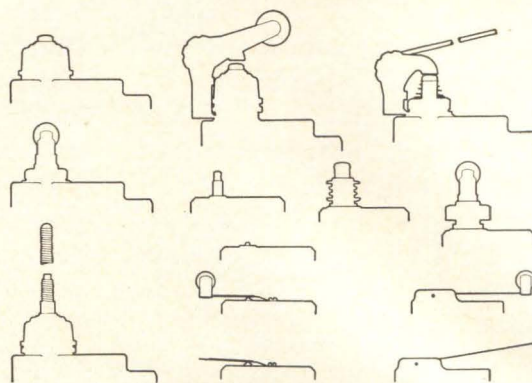

A wide selection of actuators to accommodate every operating requirement.

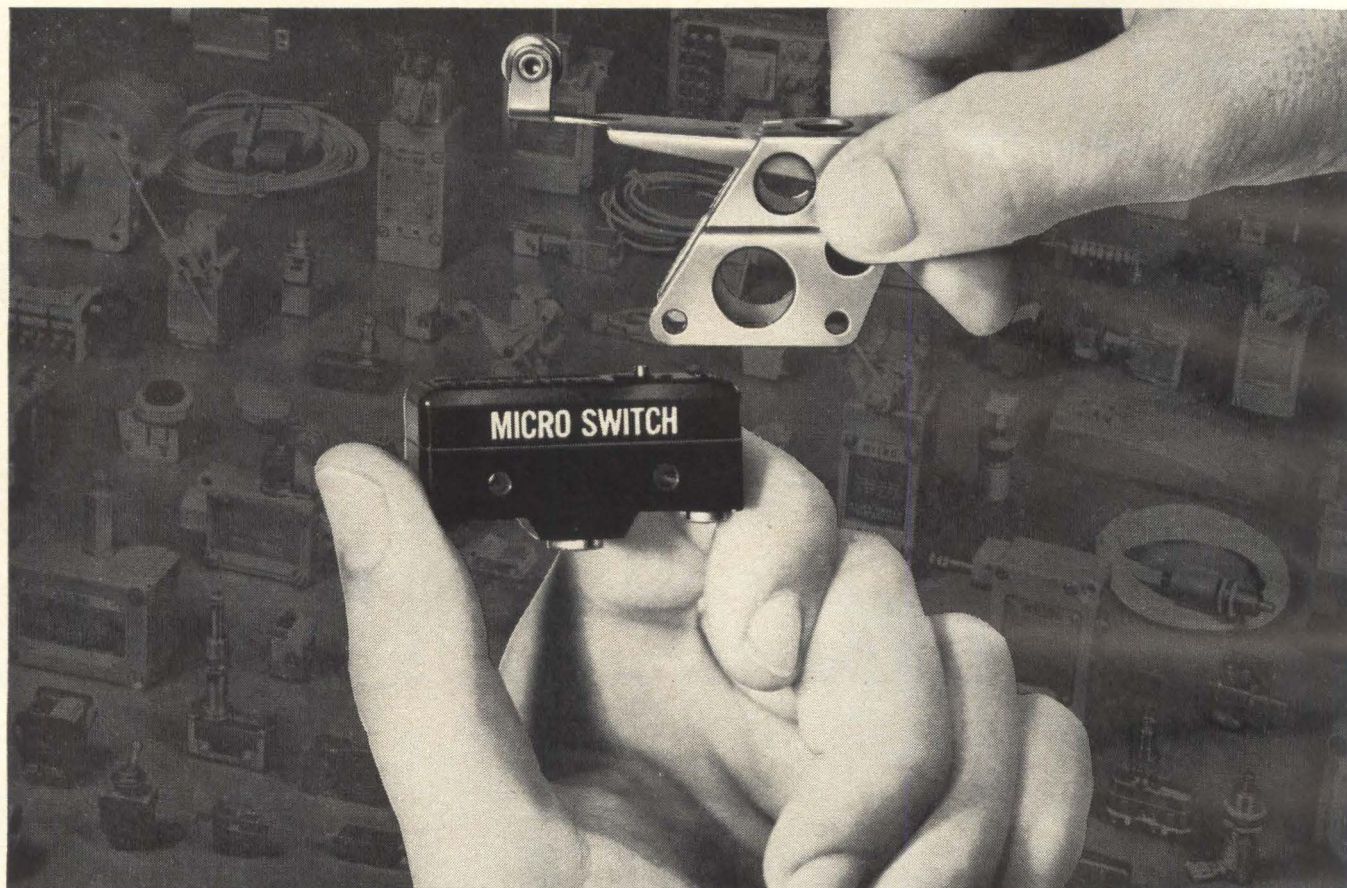

Cost-cutting ideas in switch actuation

You can often reduce your design and assembly costs by using a ready-made switch actuator.

For example, the proper actuator can eliminate complicated linkages or space-consuming brackets.

You can be sure of finding the right actuator in the MICRO SWITCH line—the world's largest. Here you will find actuators to accommodate every type of operating motion: rollers, levers, springs and rods, both integral and auxiliary types, for single and gang-mounted switches.

Before you spend time on a special method of actuation, call a MICRO SWITCH Branch Office or Authorized Distributor (see Yellow Pages, "Switches, Electric"). Or, write . . .

MICRO SWITCH

FREEPORT, ILLINOIS 61032

A DIVISION OF HONEYWELL

Amperex



are now available in production quantities for a wide range of hybrid I.C. applications including:

RF, IF, AUDIO and LOW NOISE AMPLIFIERS, OP AMPS
D to A CONVERTERS, HIGH VOLTAGE or HIGH CURRENT SWITCHES,
OSCILLATORS, MIXERS, MULTIPLIERS, DECODERS and many more.

You can get off-the-shelf delivery, right now, of seven basic groups of silicon planar NPN and PNP transistors and two families of dual diodes packaged in the new Amperex LDS. These nine groups of microelectronic semiconductors, functionally replace hundreds of different types for all your hybrid applications listed above.

HIGH SPEED SWITCHES (NPN)

LDS 200
LDS 201

functionally replace the following types:

2N706 2N744 2N914
2N708 2N834 2N2368
2N743 2N835 2N2369

GENERAL PURPOSE AMPLIFIERS (NPN)

LDA 402
LDA 403

functionally replace general-purpose amplifiers operating from 1 to 100 ma, such as:

2N696 2N2218
2N697 2N2219
2N1613 2N3390
2N3391

DUAL DIODE-COMMON CATHODE GENERAL PURPOSE and HIGH SPEED SWITCHING DIODE

LDD 10

The LID, introduced by Amperex last March, is the all-ceramic microelectronic package for semiconductors which brought mechanized production to hybrid integrated circuit manufacture. Smaller (0.075" x 0.045" x 0.032") and less costly than any existing metal package, it has already become the standard



of the industry. To learn more about the immediately available LDS listed above and about additional transistors and diodes which will soon be available in the Amperex LID package, write: Amperex Electronic Corporation, Semiconductor and Receiving Tube Div., Dept. 371, Slatersville, Rhode Island 02876.

MEDIUM CURRENT AMPLIFIER AND SWITCH (NPN)

LDA 404
LDA 405

(COMPLEMENT TO LDA 452 AND LDA 453)

functionally replace the following types:

2N2217 2N2220 2N1711
2N2218 2N2221 2N718A
2N2219 2N2222 2N871
2N1613

HIGH FREQUENCY RF AMPLIFIER (NPN)

LDA 406

functionally replaces type 2N918

GENERAL PURPOSE AMPLIFIER AND SWITCH (PNP)

LDA 450
LDA 451

functionally replace the following types:
2N2604, 2N2605

HIGH GAIN, LOW LEVEL AMPLIFIERS (NPN)

LDA 400
LDA 401

functionally replace the following types:

2N929 2N2483
2N930 2N2484

MEDIUM CURRENT AMPLIFIER AND SWITCH (PNP)

LDA 452
LDA 453

(COMPLEMENT TO LDA 404 AND LDA 405)

functionally replace the following types:

2N2904 2N2906
2N2905 2N2907

DUAL DIODE-COMMON ANODE GENERAL PURPOSE and HIGH SPEED SWITCHING DIODE

LDD 50

Amperex

**Everything's
a filter**

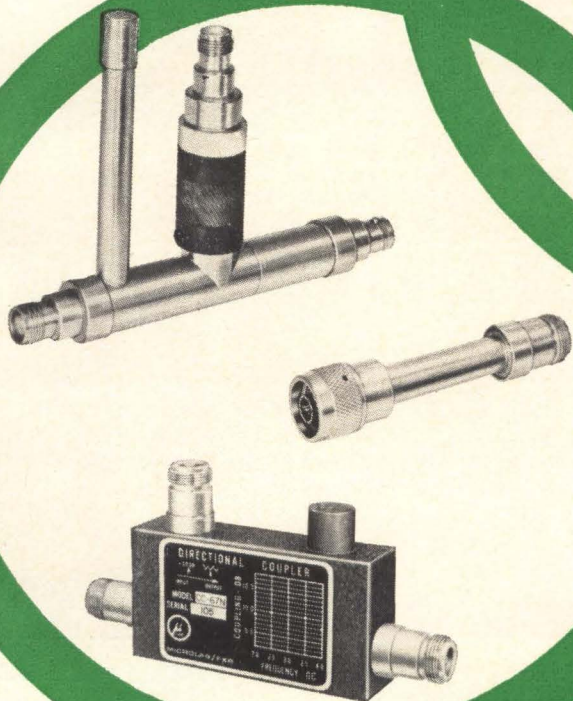
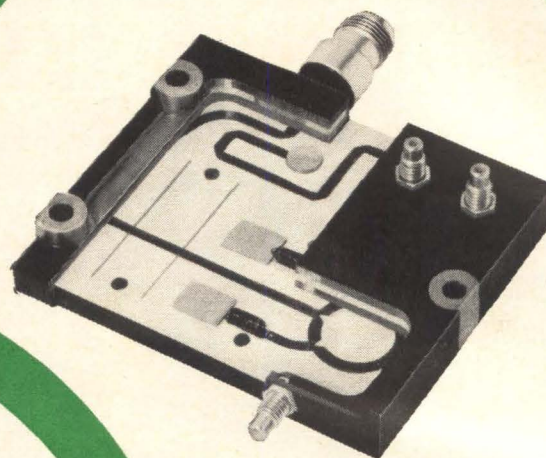

**in
microwave
sub-assemblies**

—that's why we make better sub-assemblies!

When designing a microwave sub-assembly, practically everything becomes a filtering problem. And we're not talking about just the filters themselves. Couplers, mixers, detectors—everything up to and including the launchers—interact and determine the frequency characteristics of the entire sub-assembly.

So, final sub-assembly performance starts with superior filtering knowledge. Over the years, Microlab/FXR has designed and produced more filters and other microwave components than anyone else. In the process, we've had to learn more about how these components interact—how they should be designed and packaged to minimize the effects of shock, vibration, temperature and altitude—and how to optimize the per-

formance of a sub-assembly built upon such components.

One result of this experience is the stripline sub-assembly above. It includes a mixer, two directional couplers, a filter, two terminations and a diode switch—all in a 5-ounce epoxy-encapsulated package just $3\frac{1}{2}'' \times 2\frac{1}{2}'' \times \frac{1}{2}''$. Similar sub-assemblies can be supplied for any microwave frequency and bandwidth, using these same techniques.

Let us bring our skills to your microwave sub-assembly problem. Our services can include everything from the technical proposal through value analysis, production and acceptance testing. Write today for more information, as well as a free copy of our catalog of standard microwave products. Address: Dept. E-60.



MICROLAB/FXR

Livingston, New Jersey 07039 Phones: (201) 992-7700; (212) 721-9000

Technical Articles

Monolithic IC techniques produce first all-silicon microwave switch
page 76



The most ambitious of several government-sponsored programs to develop integrated circuits for microwave equipment has started to bear fruit. Using monolithic techniques, the author has produced a transmit-receive switch that is all silicon. It can handle one watt of continuous power at about 9 gigahertz. Next will be the development of a balanced mixer and a 500-megahertz amplifier. On the cover is a disk on which are incorporated 100 switches.

Computer-aided design: part 5, Doing a model job
page 82

One critical problem in using a computer to help design electronic circuits is describing devices so the computer can recognize them. In fact, how well the engineer describes the semiconductor device can make the difference between a high-performance circuit and a mediocre one. Bad models yield inaccurate results. Here are some tips to help offset the computer's lack of engineering intuition.

Integrated circuits in action: part 4
Postmortems help prevent future failures
page 92

As integrated circuits go into a widening range of equipment, the cause of failure is interesting an increasing number of people. In determining why integrated circuits fail, bad ones are more valuable than good ones. But the cause of failure may be improper application rather than faulty fabrication or design.

Chronometer expands pulses to measure nanosecond intervals
page 108

An inexpensive but accurate instrument resolves time intervals down to 10 nanoseconds and makes it possible to display the time interval data on a low speed oscilloscope. The technique of pulse stretching is usable in a variety of instrumentation applications that range from optical range finding to counting nuclear pulses.

Coming
February 6

- Redundant integrated circuits that use little power
- A digital phase shifter
- Computer programs to aid design
- Designing a computer for command and control

Monolithic IC techniques produce first all-silicon X-band switch

Transmit-receive device developed for radar project shows that diodes and microstrip transmission line can be fabricated directly on a silicon substrate

By Alfred Ertel

Texas Instruments Incorporated, Dallas

Planar techniques used to manufacture monolithic integrated circuits can now be used to build arrays of uniform, high-quality IC's operating at microwave frequencies. The first IC microwave circuit—an all-silicon transmit-receive switch—handles 1 watt of continuous power at around 9 gigahertz; it sustains peak powers of 50 watts, and even higher powers are anticipated.

The circuit, 100 mils square and 10 mils thick, also demonstrates the feasibility of fabricating microstrip transmission line—used to connect the microwave-frequency portions of the switch—directly onto the silicon substrate.

The switch was developed by Texas Instruments under the Air Force project MERA, for molecular electronics for radar applications, the most ambitious of several Government-sponsored microwave-IC programs. An X-band balanced mixer and a 500-megahertz amplifier are also under development for this project, which aims to produce a phased-array radar made up of microwave IC's.

All of the factors that make monolithic integrated circuits practical at lower frequencies also apply to a microwave structure:

- Devices can be fabricated in place and pro-

duced by batch-processing techniques that tend to increase the over-all reproducibility and reliability of the circuit.

- Semiconductor substrates provide the best thermal-transfer medium because the devices are actually a part of the medium.

- Dimensions can be held to more exact values in the monolithic circuit because the same photographic masks control the position of both the active devices and the rest of the circuit (ideal for critical higher-frequency circuits).

- The monolithic approach may result in generally lower fabrication costs, though this will depend to a large extent on the number of processing steps and the yield at each step.

The monolithic structure used by TI represents one of the two major approaches being taken by the organizations developing microwave integrated circuits. The other involves a hybrid technique in which active semiconductor-device chips are bonded into a circuit fabricated on a different substrate material. Both approaches are, of course, aimed at developing extremely reliable microwave equipment that is at the same time compact and lightweight.

The hybrid structure generally offers greater versatility. Only good active devices are selected for bonding into the circuit, and those that become defective can often be readily replaced. The size of many passive microwave elements, such as filters and chokes, depends on the operating wavelength. The present size limitations on good-quality, high-resistivity silicon make the hybrid structure a necessity at the lower microwave frequencies. (Of course, the silicon crystal can be sliced parallel to the axis of growth to yield larger-area slices. But

The author



Alfred Ertel is a project manager in the Silicon Research and Development Laboratory's MERA program at Texas Instruments. Formerly manager of rectifier development, he is currently chairman of JS-2, the committee on small signal diodes of the Joint Electron Devices Engineering Council.

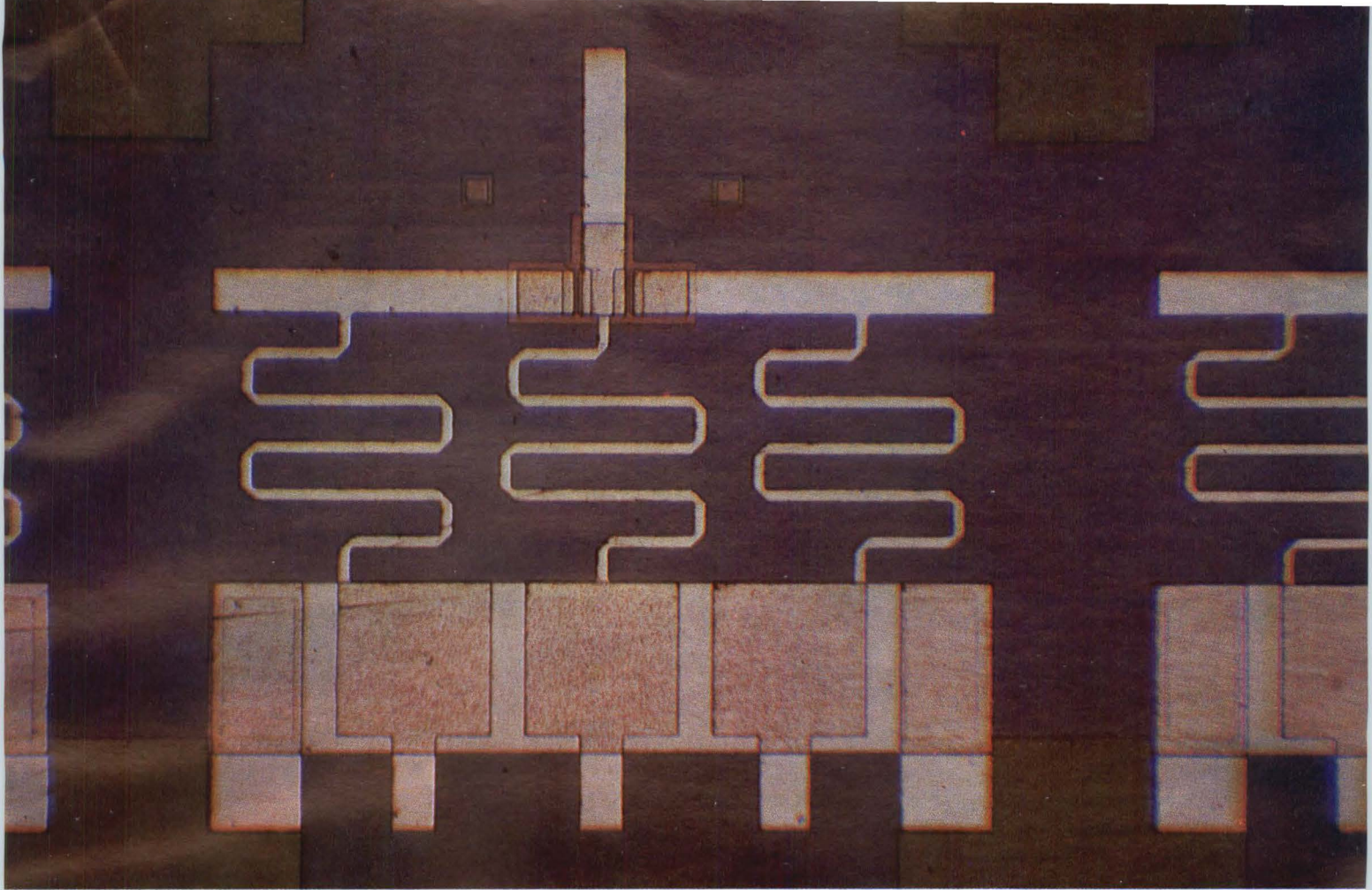

Monolithic 9-GHz transmit-receive switch is integrated on a 10-mil-thick silicon chip 100 mils square. R-f portion of the switch, including p-i-n diodes and quarter-wavelength meander-line chokes, is built on microstrip transmission line. Thin-film capacitors are deposited atop the silicon.

here too there are limitations in width and there would probably be greater processing difficulty.)

Structure of the switch

The switch is designed for use in a system with a characteristic impedance of 50 ohms.

The microstrip transmission line, or rather its 6-mil-wide upper metallic conductor, looks like an inverted "T," with the center leg being the antenna lead and the crossarms being the input and output r-f leads.

Two single-pole, single-throw p-i-n diodes are located at the base of the center leg of the T. Decoupling elements in the form of quarter-wavelength chokes, bypassed by thin-film capacitors, allow bias to be applied to the diodes without seriously affecting the r-f transmission properties of the microstrip line. Bias voltage for switching the diodes can be as low as 1 to 1½ volts. At an input power of 1 watt, peak-to-peak voltage of the radio frequency signal is 40 volts.

A metallic ground plane for the microstrip covers the entire underside of the silicon chip. However, there is another ground plane on the top of the silicon that forms the undersurface of the film capacitors, and this surface connects to the two outside pads, one at each side of the bottom of the chip. The two planes are joined in the external circuitry. Forty-one complete circuits fit on a single

1-inch-diameter silicon slice.

The properties of the microstrip line depend on its dimensions. Characteristic impedance varies with the ratio of the width, w , of the microstrip to the thickness, h , of the silicon dielectric, shown plotted at the bottom of the next page.^{1,2}

For microstrip of 50-ohm characteristic impedance, the w/h ratio is 0.6. Thus, the w dimension must be 6 mils wide for 10-mil-thick silicon.

The circuit is fabricated on p-type silicon with a resistivity greater than 1,500 ohm-cm to keep the line loss low. With this resistivity, power attenuation is 0.5 db/cm; the loss increases rapidly with decreasing resistivity. Unless precautions are taken,

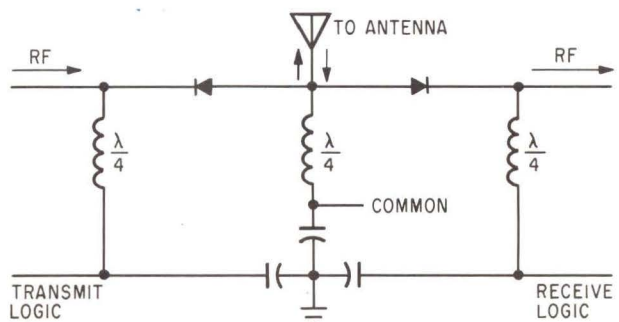

Equivalent circuit of transmit-receive switch reflects corresponding areas in the integrated design.

heat treatment of the material during processing will convert high-resistivity (greater than 1,000 ohm-cm) p-type silicon to a relatively lower resistivity n-type; the resulting excessive r-f losses then make it worthless as a transmission-line dielectric. Processed correctly, the silicon will maintain its high resistivity even if it does convert to n-type material.

Quarter-wavelength chokes

To conserve space, the quarter-wavelength decoupling chokes have been given a meander-line shape. At 9 Ghz, the ratio of wavelength in free space to wavelength in the microstrip is 2.78 for a 10-mil-thick high-resistivity silicon substrate; using this value gives a nominal quarter wavelength in the silicon of 118 mils. In practice, this length has to be adjusted for mutual coupling between the turns of the meander line.

A 15% increase in length to 136 mils appears satisfactory. The microstrip for the chokes is 2 mils wide, resulting in a characteristic impedance of 70 ohms.

Bypass capacitors

The three thin-film bypass capacitors are designed to provide an r-f path to ground having less than 1 ohm impedance at X band (5,200 to 10,000 megahertz). The dielectric is silicon dioxide stemming from the thermal decomposition of silane in an oxygen atmosphere. With a thickness of approximately 4,000 angstroms of oxide, the capacitance per unit area is 0.07 picofarads per square mil. The total area per capacitor is 400 square mils, giving a reactance of $\frac{1}{3}$ ohm. Both aluminum and molybdenum-gold metal systems have been used with equal success in fabricating the circuits.

Switching diodes

The switching diodes in the circuit are of the surface-oriented type.^{3,4} This is one in which the anode and cathode areas are adjacent at the sur-

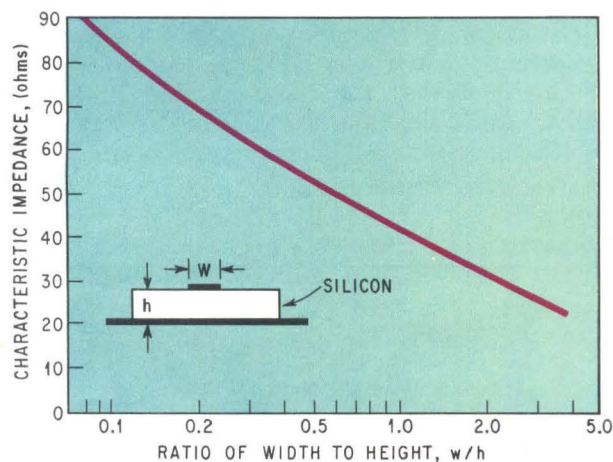

Characteristic impedance of a microstrip line on silicon dielectric varies with the ratio of stripline width, w , to the thickness of the dielectric, h . For TI's 50-ohm system, the strip is 6 mils wide.

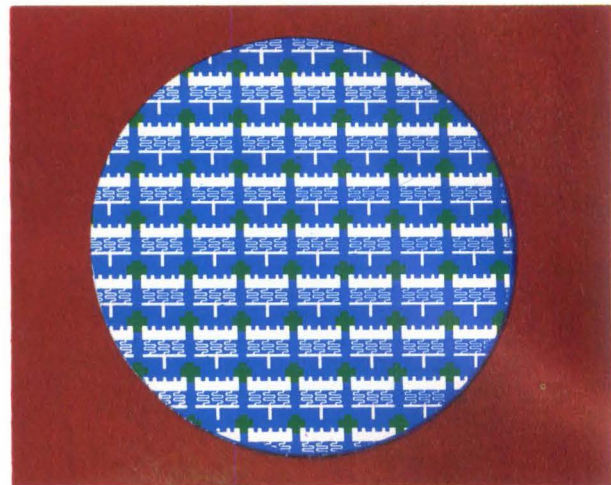

Forty-one complete microwave circuits fit on a single 1-inch-diameter slice of silicon.

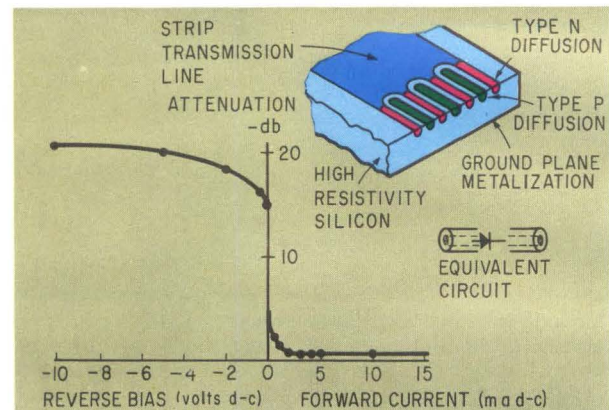

Surface-oriented p-i-n switching diode can be diffused directly into silicon. Attenuation curve is for design providing minimum of 25-db isolation at 500 Mhz.

face of a silicon chip. Carrier flow under bias is approximately parallel to the surface.

Such diodes have several advantages for microwave integrated circuits, whether hybrid or monolithic:

- They are compatible with microstrip construction.
- Capacitance under reverse-bias conditions may be made quite small and even adjusted during processing, within limits, by varying the depth of diffusion.
- Heat generated is dissipated readily because the p-n junctions are parallel to, and close to, the excellent heat sink formed by the ground plane.

A surface-oriented diode similar in principle to the τ -R switch diode consists of one set or more of anode and cathode diffusions into high resistivity silicon, shown above. These diffusions can be connected directly into a microstrip line.

A seven fingered surface-oriented diode has been designed for a minimum of 25-db isolation on reverse bias at 500 Mhz (photo next page). All cathode diffusions are interconnected to join the

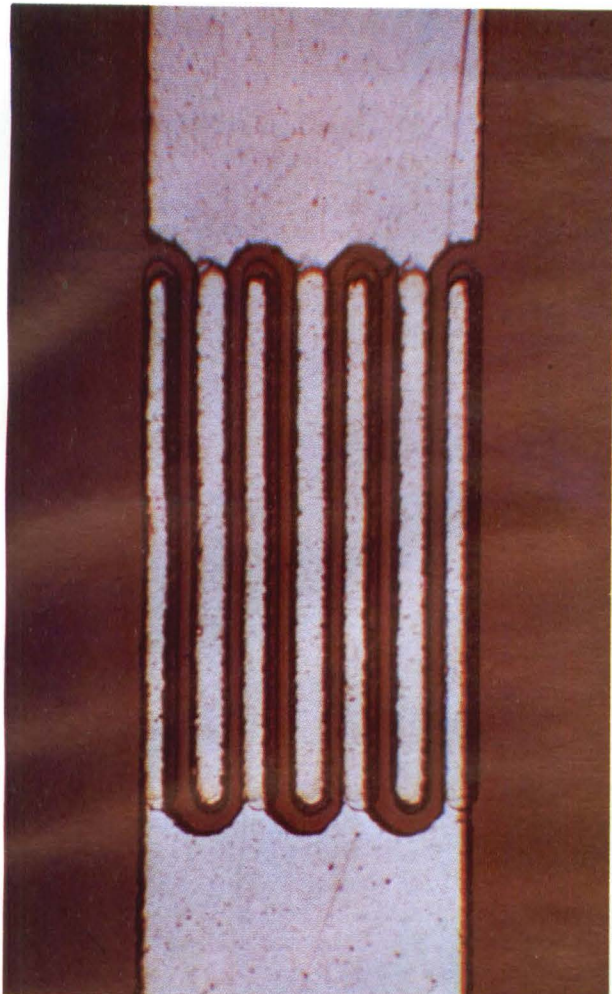

Seven-fingered surface-oriented diode has cathode diffusions joining the microstrip to the top, anode diffusions joining the microstrip to the bottom. Reverse bias capacitance is about 0.18 pf.

portion of the microstrip going off to the top. Capacitance of the reverse-biased diode is approximately 0.18 pf, far too large, incidentally, to give a useful level of isolation at X band. (What appear to be cracks at the silver-colored bases of some of the diode fingers result from the way light strikes the window areas opened in the silicon dioxide during the diode diffusions.)

To achieve the same 25-db isolation at 9 Ghz, the reverse-bias capacitance must be reduced to about 0.01 pf. Here is where the inherent advantage of the integrated surface-oriented diodes comes into play. In a conventional solid state microwave switch using packaged diodes, the diodes are mounted in series or in shunt with the transmission line. Generally the series configuration isn't used at frequencies above 4 Ghz because the diode's reverse-bias capacitance, which includes a package capacitance, is too large.

In this circuit, however, a series diode configuration is no problem at all at X band. Very low capacitance can be obtained by using a special type of surface-oriented device, called a "gap" di-

ode because it has only one anode area and one cathode area separated by a small gap of high-resistivity material. For the diode size and gap spacing used, reverse-bias capacitances as low as 0.005 to 0.008 pf are obtained, providing an isolation at 9 Ghz of 31 to 27 db, respectively.

Consider the forward bias condition of one of the diodes of the T-R switch with the other biased off. The insertion loss, δ , of a series diode switch in a 50-ohm transmission line is given by the relation $\delta = 10 \log [(1 + R_s/100)^2 + (X/100)^2]$ where X, the reactance resulting from charge storage capacitance, is very small and can be ignored.⁵ R_s , the series resistance, is the major contributor to the total loss. The effect of excess amounts of series resistance can be gauged by examining a semilogarithmic plot of the diode equation, shown at the bottom of the next page.

This plot should be a straight line of slope $e^{q/2KT}$ if no series resistance is present and the voltage drop is entirely due to current passing through the junction impedance. If excess series resistance is present, the additional drop resulting from it shows up on the semilogarithmic plot as a curve deviating from this ideal straight line, especially at higher values of current. A diode giving a straight-line plot will provide a minimum insertion loss in the circuit. There are other considerations, however, to be discussed further on, which may contribute to higher levels of insertion loss in a silicon monolithic microwave circuit.

Gap diodes

The gap diodes in the switch are designed to operate in a "punch-through" condition when reverse biased. Under this condition, the high resistivity region becomes intrinsic and the reverse-biased diode resembles a parallel plate capacitor. Capacitance is fairly independent of voltage beyond punch-through. Therefore, circuit and diode design are simplified and actual bias voltage depends only on r-f peak voltage considerations. Switching characteristics are independent of r-f power over a wide range.

Using the equation for insertion loss given above, Garver⁵ has shown that the reverse-biased isolation, η , of a series diode switch in a 50-ohm transmission line is very nearly equal to $20 \log (|X|/100)$ when $R_s/Z_0 \ll 1$ and $X/Z_0 \geq 6$. The equation for η may be used to determine the value of the reverse-bias capacitance by measuring the power incident on a power meter both with and without the monolithic chip (in its test jig) connected into the test equipment. The diode leg being tested for isolation is reverse biased and the other leg forward biased. The capacitance is then determined from the value of X calculated at the test frequency.

Package capacitance is insignificant. Metal-oxide-silicon capacitance formed by the metallic stripline, the oxide and the silicon substrate is very much in evidence at 1 Mhz when measured by a capacitance bridge, but it disappears at microwave

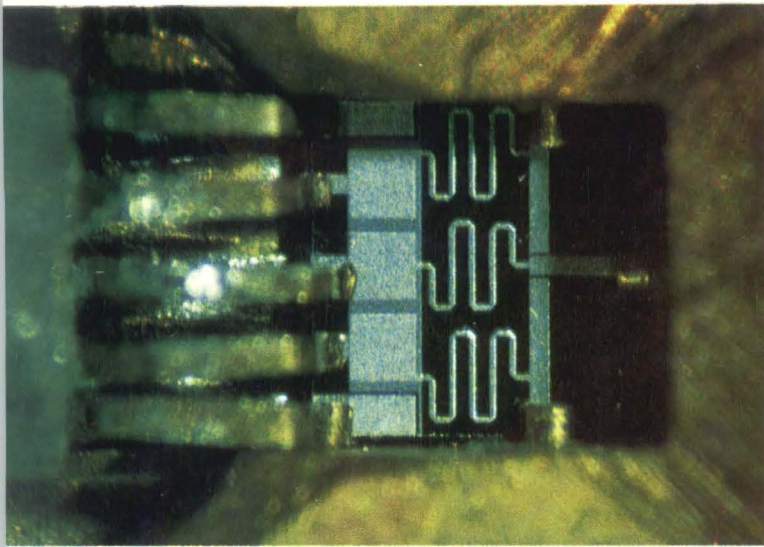

Test jig built for handling 100-mil-square circuit chip has three coaxial connectors for the r-f lines. D-c connections are through the contacts at right.

frequencies.⁴ The resistance of the high-resistivity substrate in series with this MOS capacitance completely negates the MOS capacitance.

On reverse bias, the diode equivalent circuit consists of the voltage-dependent barrier capacitance C_B shunted by a very large-value resistive component R_B and a lumped equivalent of the MOS capacitance in series with the resistance, R_N , of the substrate.

The parallel equivalent of this circuit, as shown, combines the MOS capacitance and the barrier capacitance into one value, C_P , and does the same for the conductance portion of the admittance. C_P and R_P can be calculated from known or assumed values of C_B , R_B , C_{MOS} and R_N . This shows

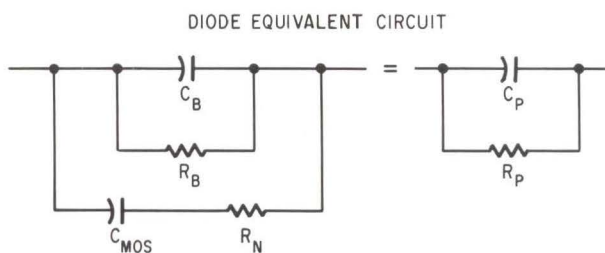

$$Y = \left(\frac{1}{R_B} + \frac{R_N}{R_N^2 + X_{MOS}^2} \right) + j \left(\frac{1}{X_B} + \frac{X_{MOS}}{R_N^2 + X_{MOS}^2} \right)$$

$$= \frac{1}{R_P} + j \frac{1}{X_P} = \frac{1}{R_P} + j\omega C_P$$

At microwave frequencies, the equivalent parallel capacitance, C_P , is essentially equal to the barrier capacitance, C_B . The MOS capacitance is negligible.

Series resistance, R_s , in the gap diodes causes diode characteristic to tail off from ideal straight line.

that at high frequencies C_P is identical with C_B over a wide range of assumed values of substrate resistance R_N , and that the MOS capacitance doesn't enter into the picture at microwave frequencies.

Semiconductor dielectrics

The minimum insertion loss possible in a microwave monolithic integrated circuit depends on the transmission-line properties of the semiconductor substrate. The components interconnected by the microstrip have various potentials on their electrodes and terminals, and current paths to ground may be set up unless precautions are taken.

The cross section of a microstrip transmission line containing a gap diode, next page, shows the possible r-f and d-c conduction paths to ground. Resistances represent the high values of the d-c leakage paths that may exist across the protective oxides and the silicon substrate. Capacitances are part of the r-f transmission-line representation. Paths from microstrip to ground are shown, but not resistances parallel to the transmission line.

If the contact between the metal stripline and the silicon is ohmic and no junction barrier exists, current can flow with equal ease in either direction, depending upon the polarity of the applied bias. The magnitude of current depends entirely on the resistance of both the metallic and semiconductor layers. If a potential barrier exists either in the silicon or at the interface of the metal and semiconductor, current flow is enhanced in one direction of applied bias and suppressed in the other.

Uncombined carriers, produced in a semiconductor by a potential applied across it, effectively lower the apparent resistance of the region, a phenomenon known as conductivity modulation. This current flow degrades the dielectric properties of the semiconductor.

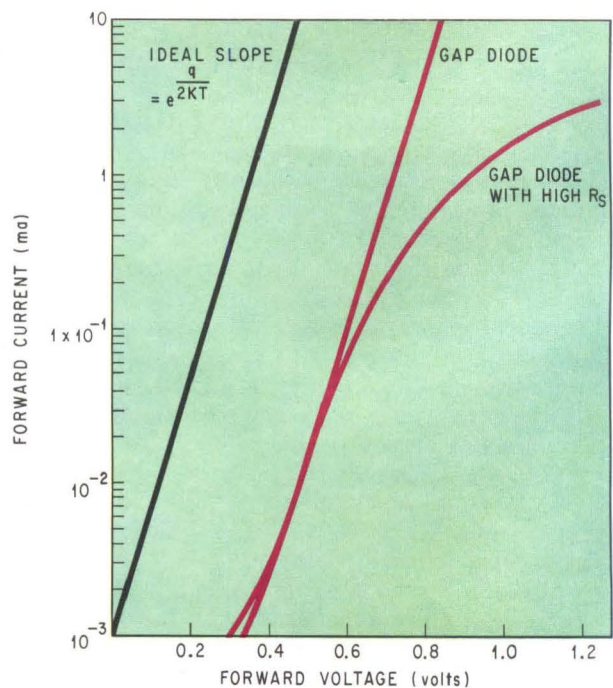

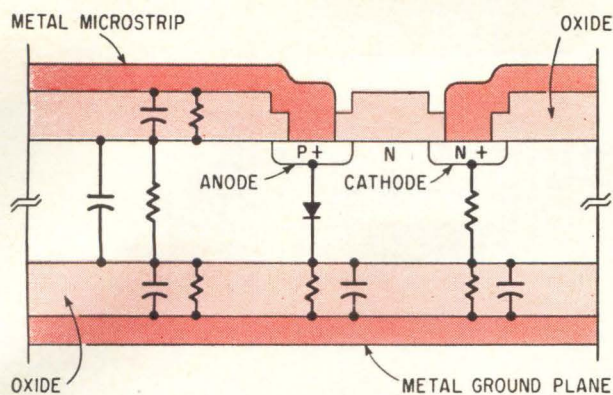

Section of microstrip transmission line containing a gap diode shows possible r-f and d-c conduction paths. Oxide layer at bottom—made of silicon dioxide, silicon nitride or vapor-deposited silicon carbide—open-circuits d-c path to ground.

When a potential barrier exists between a semiconductor electrode and the high-resistivity substrate, the unidirectional d-c flow may be inhibited by reverse biasing this semiconductor junction with respect to ground. D-c leakage through ohmic contacts may not be stopped this way, but direct current through the high-resistivity semiconductor substrate can be eliminated completely by providing an insulating layer—the lower oxide layer shown in the cross section—between the ground plane and the semiconductor body. This layer won't affect the uhf or microwave transmission properties of the microstrip, but will effectively open-circuit any d-c path to ground. It thus prevents a loss of dielectric properties of the high-resistivity semiconductor by preventing conductivity modulation.

The insulating layer can be of any suitable material, organic or inorganic. Silicon dioxide, silicon nitride and vapor-deposited silicon carbide⁶ have been used with equal success.

Testing the complete circuit

The switching performance of the complete circuit has been evaluated at frequencies of 8 to 11 Ghz. A special test jig was required to hold the 100-mil-square chip. The r-f connections are made to the three coaxial connectors; the d-c connections are made through the wires attached at the right of the jig, shown in photo, page 80.

Swept-frequency oscilloscope traces were taken in a wave-guide system to measure voltage standing wave ratio and insertion loss. With the diodes properly switched by d-c bias, the lowest loss was found at 9 Ghz. VSWR of the jig and chip at this frequency was 1.43.

The performance achieved to date:

Frequency range	8 to 9 Ghz
Insertion loss	1.5 to 2.0 db
Isolation	25 to 27 db
Power	1 w c-w
Peak pulsed power	50 w

In contrast, a comparable conventional solid state switch has an insertion loss of 1.0 to 1.5 db

at 8 to 12 Ghz and a maximum switch power dissipation of 1.25 watts. It's estimated that with improved testing techniques and reevaluation of power-handling capability, insertion loss of the monolithic circuit will be reduced to 1 db and power handling increased.

The insertion effects of the quarter-wavelength chokes were tested by short-circuiting one side of the "T" to simulate a diode turned on, and open-circuiting the other side to simulate one turned off. This formed an "L" with two chokes hanging from one r-f conducting leg.

Power-switching capability

The circuit is intended to operate continuously at 1 watt. Since the power into the diode can be shown to equal $P_i = E_m^2/8Z_0$, the peak voltage of the r-f signal will be 20 volts, giving a peak-to-peak value of 40 volts. Diode breakdown voltage (including a safety factor) may be as little as 30 to 35 volts as long as the peak of the r-f voltage plus the bias voltage is less than the breakdown voltage.

At 9 Ghz, bias voltage need only be greater than the punch-through voltage for the full isolation level to be reached; this can be as low as 1 or 1½ volts. Tests have shown that almost half the amplitude of the peak-to-peak value of the r-f voltage can be positive without affecting the isolation characteristics of the switch so long as the period of the r-f signal is much shorter than the lifetime of the carriers.

Maximum c-w power-switching capability hasn't yet been evaluated beyond the 1-watt design. But there is every reason to believe that with the ground plane in contact with a good heat sink, power handling will at least match that afforded by a conventional solid state microwave switch. The circuit has been operated successfully with up to 50 watts peak power incident on it. Fifty watts represents a peak voltage of 141 volts incident on the diode, or an approximate electric field of 100-kilovolts/cm across the diode metalization gap.

Acknowledgment

This work was supported in part by the Avionics Laboratory Research and Technology Division, Air Force Systems Command, under USAF Contract No. AF33 (615)-2525.

References

1. T.M. Hyltin, "Microstrip Transmission on Semiconductor Dielectrics," IEEE Transactions on Microwave Theory and Techniques, Vol. MTT-13, November 1965, p. 777.
2. J.D. Welch and H.J. Pratt, "Losses in Microstrip Transmission Systems for Integrated Microwave Circuits," NEREM Record, Northeast Electronic Research and Engineering Meeting, 1966, p. 100.
3. A. Ertel, "Surface Oriented Diodes for Microelectronic Applications," Electrochemical Society Meeting, May 1965.
4. A. Ertel, "Microwave Evaluation of Surface Oriented Switching Diodes," International Electron Devices Meeting, October 1965.
5. R.V. Garver "Theory of TEM Diode Switching," IRE Transactions on Microwave Theory and Techniques, Vol. MTT-9, May 1961, p. 224.
6. K.E. Bean and P.S. Gleim, "Some Properties of Vapor Deposited Silicon Carbide," submitted to the Electrochemical Society for publication.

Computer-aided design: part 5

Doing a model job

The circuit designer would like to tell a computer:

'Here's what we have, and here's what we want to know.'

But setting up active-device models is still a complex task

By Cyrus O. Harbourt

University of Texas, Austin

How accurately a designer describes a semiconductor device to a computer can make the difference between a high-performance circuit and a mediocre one. Bad models yield inaccurate results.

Computer systems don't have the intuition, experience and common sense of the engineer. And unless these qualities are reduced to an appropriate set of hole-punched cards the machine won't perform efficiently. To some extent the computer's speed and storage capacity offset its lack of engineering judgment. But the machine's advantages best complement good engineering, not substitute for it.

Some circuit elements such as resistors can quite readily be represented to the computer. But diodes, transistors and other active devices are not linear and their reactions to temperature and frequency are difficult to describe mathematically.

There is no optimum transistor model applicable to all design goals. Two ideal diodes and a dependent current source may satisfactorily represent the state of transistors in a saturating logic circuit, while an equivalent circuit with eight small-signal parameters might be just the thing to calculate a video preamplifier frequency response. But

neither of these models precisely determine the offset voltage in a high-quality analog gate circuit.

Transistor information in a form and quantity suitable to computer analysis is rarely found entirely on manufacturers' data sheets, and to obtain required data elsewhere is expensive. If a circuit analysis program is to be applied to a wide variety of problems, therefore, it must contain provisions for the most complex design models anticipated. On the other hand, while computers can usually handle more data than they need to analyze a problem, too much information reduces program efficiency. For less involved problems, a program should omit large portions of the complex model.

Basic concepts of model-making

A model is a mathematical representation of the behavior of a real device, in which external variables simulate real signals, inputs, excitations or environmental stimuli. Besides accurately predicting the performance of a complex electrical device, a model must be characterized by parameters derived from practical measurements of actual devices and must be subject to analysis.

Other desirable, but not essential, factors are that the model be formed from conventional lumped circuit elements and that its parameters directly correspond with the internal physical properties of the device being represented.

Rarely do the internal variables in a model have physical counterparts in the real device, but this, fortunately, is not a requirement. A model must only answer those questions pertaining to external variables; its adequacy is properly judged only on the accuracy of the predictions based on it. In any case, a model performs accurately only over a specified range of device behavior; there are always

The author



Cyrus O. Harbourt received his Ph. D. from Syracuse University, N.Y., in 1961. Now an associate professor at the University of Texas, he is currently doing research on experimental threshold gates in computer circuits, and modeling devices for computer-aided design.

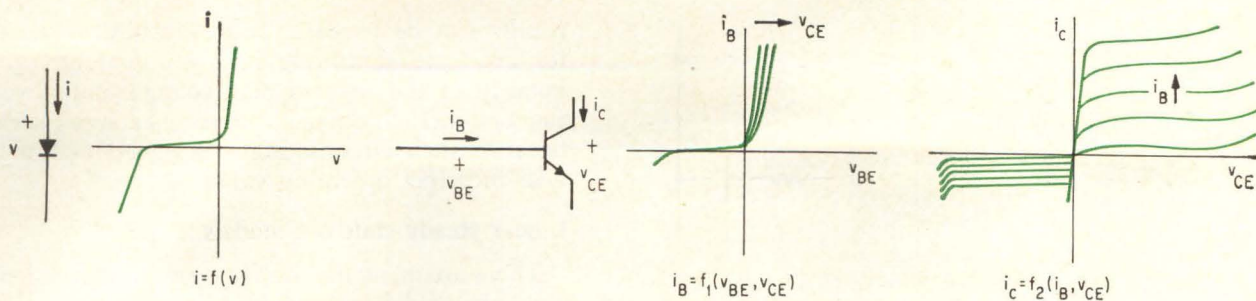

Typical characteristic curves for the diode, left, and the transistor, right, are basic input information for the computer when modeling devices. The designer sets up a mathematical relationship that describes the curves in terms of a circuit model.

conditions outside that range for which it fails.

A model need not be derived from first principles. It can be developed on a practical or whimsical basis and tested by comparison with experiments.

It is relevant to consider the various properties that transistor models can have. They can be connected in common-base, common-emitter or common-collector configurations. They can be assembled from ordinary network elements or based directly upon the fundamental physical processes inside the transistor. However, neither the mode of connection nor the transistor's physical behavior determines the success of the model.

Good models develop from a consideration of both properties and applications. They are limited in their applications to operation in d-c, small-signal a-c or transient conditions, and can include or omit energy storage effects, temperature dependence, noise properties or radiation damage effects. A more elaborate model can be used for a specific class of problems, though with considerable waste of computer time. For example, a designer could use a nonlinear transient model for linear steady-state a-c analysis, but not efficiently.

The models can be automatically programmed, requiring only connection and type-number designation by the programmer, or they may require detailed programming of internal parts.

Models for transistors and diodes can be divided into the following categories: linear d-c models; linear steady-state a-c models; nonlinear d-c models that are further subdivided into piecewise linear, exponential nonlinear and tabulated-data types; nonlinear transient models, including piecewise linear and general nonlinearities.

Linear d-c models

The d-c model of a semiconductor diode is represented, at the above left, by the current-voltage characteristic curve, a single nonlinear function of a single variable. The external variables of the model are terminal current, i , and terminal voltage, v . Secondary effects aren't considered. For a transistor, the d-c model is represented by a pair of nonlinear functions, each of two real variables.

For linear d-c models to be of value, either their external variables must be restricted to limited regions, or the computed results for excursions

outside those regions must be monitored. The linear d-c models for such typical diodes are composed of lumped circuit elements whose values are easily inserted in any network solving procedure. However, they give erroneous results if evaluated outside their intended range.

The transistor can be modeled in similar fashion. Any external configuration can be used with appropriate restrictions on variable values.

Although these transistor models appear crude, they are quite valuable for worst-case analysis of logic circuits with saturated transistors. In such analysis, the main task is to verify the proper off and on (saturated) transistor states for specified resistor and transistor tolerances. The desired states are known in advance, and the computed

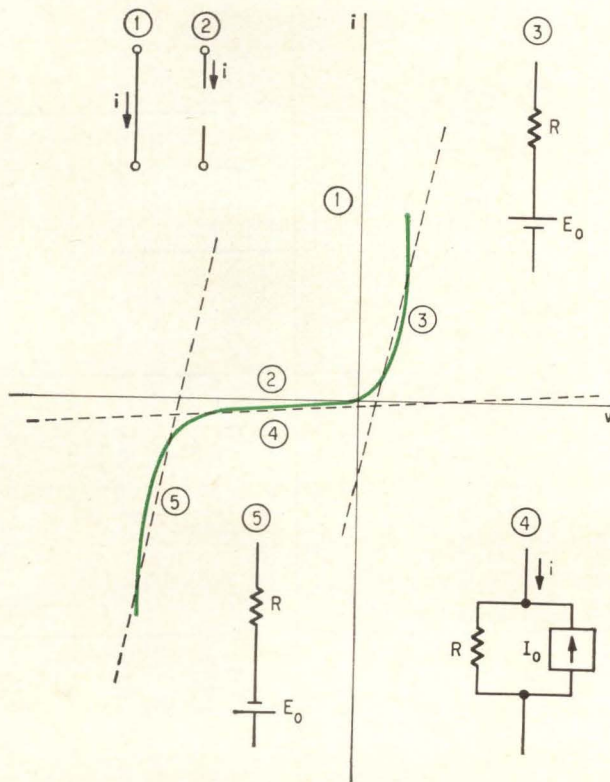

Linear d-c models for diodes are represented by five basic circuits, numbered 1 through 5. These circuits simulate the current-versus-voltage curve. Numbers shown on each portion of the curve correspond to the appropriate circuit.

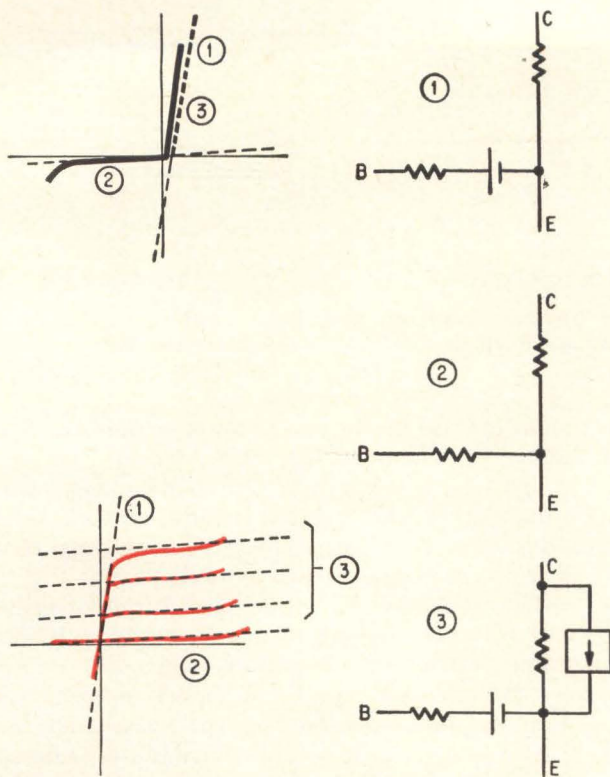

Linear d-c models for transistors are represented by three basic circuits, numbered 1 through 3. Numbered portions of the current-versus-voltage curves correspond to the circuit that simulates that portion of the curve. Circuits 1 and 2 are particularly valuable for performing worst-case analysis.

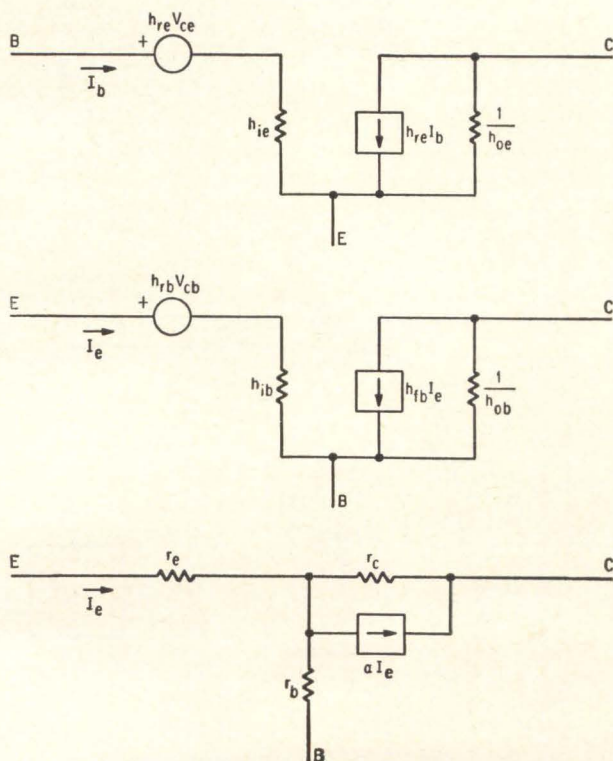

Hybrid or h-parameters of transistors in common-emitter and common-base connections (top two diagrams) and the T circuit (bottom diagram) are often applied for device modeling of small-signal a-c transistors.

results can be checked (automatically, if desired) for adequate saturating base current and proper polarity of the reverse bias voltage under worst-case conditions. Small discrepancies aren't serious because such circuits aren't designed to function near incorrect operating values.

Linear steady-state a-c models

There are many models for computing the steady-state sinusoidal currents and voltages in transistor circuits. However, if all energy storage effects inherent in the transistor are assumed negligible, any linear, incremental two-port model is sufficient. Most familiar to the transistor circuit designer is the common-emitter h-parameter model, but some manufacturers still provide parameter values for all or part of the common-base h-parameter model. An early favorite whose parameters are more easily identified with transistor operation than any other small-signal parameters is the common-base T circuit. This is of no consequence in low-frequency small-signal analysis, but is useful for more elaborate models.

In many circuits, some of the h or T parameters may have a negligible effect on computed results. For manual calculations, a circuit designer would apply simpler models if he could, but for computer assistance, it isn't worth the effort of deciding when certain parameters can be ignored in programming the problem. Little additional complexity is involved in returning all four parameters in the circuit for each transistor.

If inherent energy storage or frequency-dependent effects in the transistor can't be ignored, the task of formulating an adequate small-signal linear model is considerably more difficult. Perhaps the most elaborate lumped model of a junction transistor ever developed was Middlebrook's frequency-dependent y-parameter model.¹ Here, each parameter is realized as the driving-point admittance of a four-element network that contains only constant element values. Each element value is a complicated algebraic function of certain measurable fundamental device parameters. Middlebrook's model achieved excellent accuracy at up to four times the alpha cutoff frequency of transistors available as of 1954.

There is no longer any need for such exhaustive treatment of frequency-dependent models for modern transistors. With semiconductor technology boosting transistor cutoff frequencies, the most common solution to high-frequency circuit problems is to buy transistors that cut off beyond the highest frequencies of interest.

Nanavati's less elaborate model achieves the same results with a wideband common-emitter h-parameter equivalent circuit.² This circuit, at the left of page 85, suffers in that two of its parameters are frequency-dependent; these parameters may be represented by driving-point admittances of auxiliary, lumped-constant networks if necessary, but the model is still quite complex. In fact, a simpler circuit model, the hybrid-pi

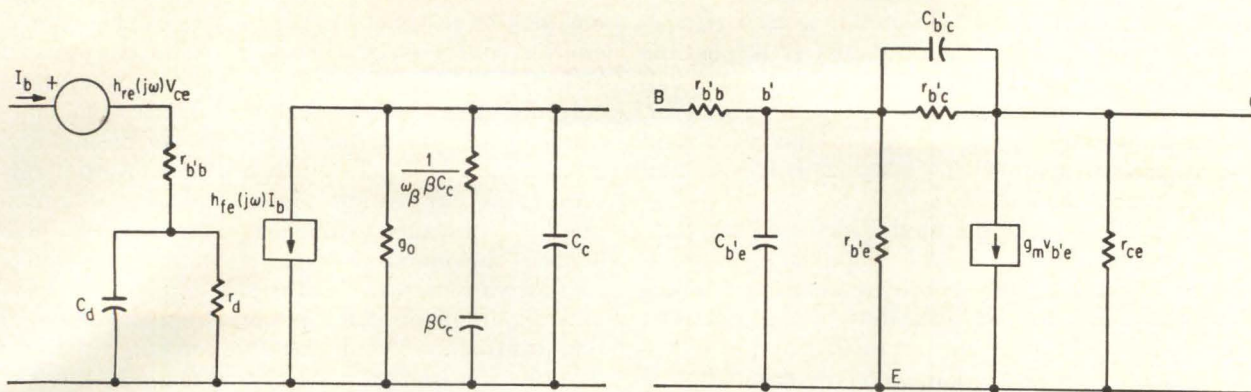

Although the circuit at the left is a good wideband h-parameter a-c model it suffers from one serious limitation—two of its parameters, h_{re} and h_{fe} , are frequency dependent. The limitation is overcome in the hybrid-pi circuit on the right.

shown at the above right of the diagram, yields frequency-dependent common-emitter h-parameters identical in form to Nanavati's. The hybrid-pi, the most useful wideband model for general analysis programs, is composed of ordinary lumped network elements, including one dependent source whose control parameter is a constant. This model is estimated as valid at up to frequencies near alpha cutoff. The parameters required are usually derived by simple calculations based on the manufacturer's published data. One possible exception is R'_{bb} , the base spreading resistance, which often is not furnished by the manufacturer and must be measured.

Although the full complexity of the hybrid-pi model isn't needed for some computations, the increased program efficiency gained from simpler special-case models isn't worth the effort of adding them to the program and deciding when they may be properly applied.

The accuracy and effectiveness of the hybrid-pi model is improved by multiplying the intrinsic transconductance, g_m , by a phase-shift factor of unit amplitude. The phase angle is dependent on the process used in making the transistor and is best determined experimentally from a frequency response curve for common-emitter current gain, β .

There are devices that aren't adequately represented by the hybrid-pi model. The special construction techniques used in very high frequency transistors require additional resistance and capacitance parameters, for example, and models for field effect transistors present problems as formidable as those for the junction transistor. It's conceivable that appropriate parameter values can be found for a valid hybrid-pi FET model, but this still remains to be done. It may also be possible to develop a single wideband model that represents all three-terminal active devices.

Nonlinear d-c models

For d-c analysis, the transistor is considered a nonlinear device when it functions beyond the useful limits of linear operation. There are three modeling techniques for analyzing nonlinear d-c models: graphical or tabulated data, piecewise-

linear networks and other nonlinear analytic forms. The direct application of graphical data as a transistor d-c model is limited for manual computation to simple circuits, and tabulated data isn't directly useful at all. But a computer program can combine graphical and tabulated data for effective analysis of nonlinear problems.

Piecewise-linear transistor models are realizable by networks of lumped resistors, dependent and independent sources, and ideal diodes. The values and arrangement of the elements are chosen to approximate as closely as desired any set of transistor characteristic curves. If the model is a three-terminal network, it may represent any transistor configuration in the circuit. Modifications are called for when a nonlinear model doesn't perform as anticipated. These modifications can be made easily if the internal parts of the model correspond to the physical internal behavior of the device, and for this reason, the piecewise linear model favored is a common-base model. This isn't an essential choice, but the common-base type represents all regions of transistor operation more simply than does a comparable common-emitter piecewise-linear model.

In the basic piecewise-linear transistor model, junction effects are approximated by ideal diodes and current transfer effects by dependent current sources. The source α_n represents normal transistor action; the source α represents inverted action in which the roles of the collector and emitter are interchanged. The model is valid in all four regions of transistor operation—cutoff, saturation, active-normal and active-inverted—but excludes breakdown effects and is too simple for good quantitative results in or near the saturation region.

A refined piecewise-linear model, center diagram on page 86, is much more accurate than the simpler one if appropriate values represent its parameters. The parameter values are readily obtainable from i_C as a function of i_E and V_{CB} ($i_C = f(i_E, V_{CB})$) and i_E as a function of i_C and V_{EB} ($i_E = f(i_C, V_{EB})$) graphical data. But characteristic curves for the instantaneous values, i_C and i_E , aren't usually used since these are not available from the

manufacturer. However, curves for $i_c = f(i_B, V_{CE})$ and $i_B = f(V_{BE}, V_{CE})$ are available. It is possible through interpolation to obtain the parameter values desired from the i_c and i_B curves. However, slight numerical errors will result, the price paid for a model that is closely linked with the internal behavior of a device.

The most accurate d-c model for nonlinear transistor representation is the popular Ebers-Moll circuit,³ shown below. It is a common-base model that represents the nonlinearities of the transistor more accurately than any relatively simple piecewise linear model can. Parameter determination is a major problem, but once a transistor is fully characterized for such a model, it is very accurate over a wide range of circuit applications.

Some attempts to derive a common-emitter version of the Ebers-Moll model have been made, resulting in an exponential nonlinearity model with very complicated results. The exponent in the emitter-collector i - v relationship cannot be reduced to a form depending on a single junction voltage. There seems to be no choice, therefore, but to stick to the common-base version and accept whatever measurement difficulties it presents.

Nonlinear transient models

A very elaborate version of the common-base model on page 87 is applied in NET-1.⁴ [See "Computer-aided design: part 1, The man-machine merger," Electronics, Sept. 19, 1966 p. 112.] It

includes 36 parameters: base spreading resistance; emitter and collector bulk resistances; junction leakage resistance; junction reverse (saturation) currents; junction temperature; current gain function (a cubic polynomial with four coefficients and a scale factor—separate forward and inverted current gains); transition region capacitances (non-linear); equivalent diffusion capacitances (non-linear); maximum voltage, current, and power ratings; various scale factors and empirically determined parameters for optimum representation of real transistors. Nonlinear i - v junction equations describe the transistor's resistive nonlinearity. The program provides for modification of individual parameters, but usually works from prestored taped data. A diode model consistent with the transistor model is also provided. A NET-1 programmer need only identify a device by 1N or 2N type number and give connection information if he is content with the stored parameter values. The program performs nonlinear d-c or transient analysis, but doesn't include junction breakdown and conductivity modulation effects. The device models are also valid for small-signal a-c analysis. Although only diode and transistor models are built in, other semiconductors could be applied. Ideal switches can be simulated in NET-1 transient analysis.

A second general analysis program is the International Business Machines Corp.'s ECAP (Electronic Circuit Analysis Program),⁵ which relies on a program-it-yourself approach to nonlinear tran-

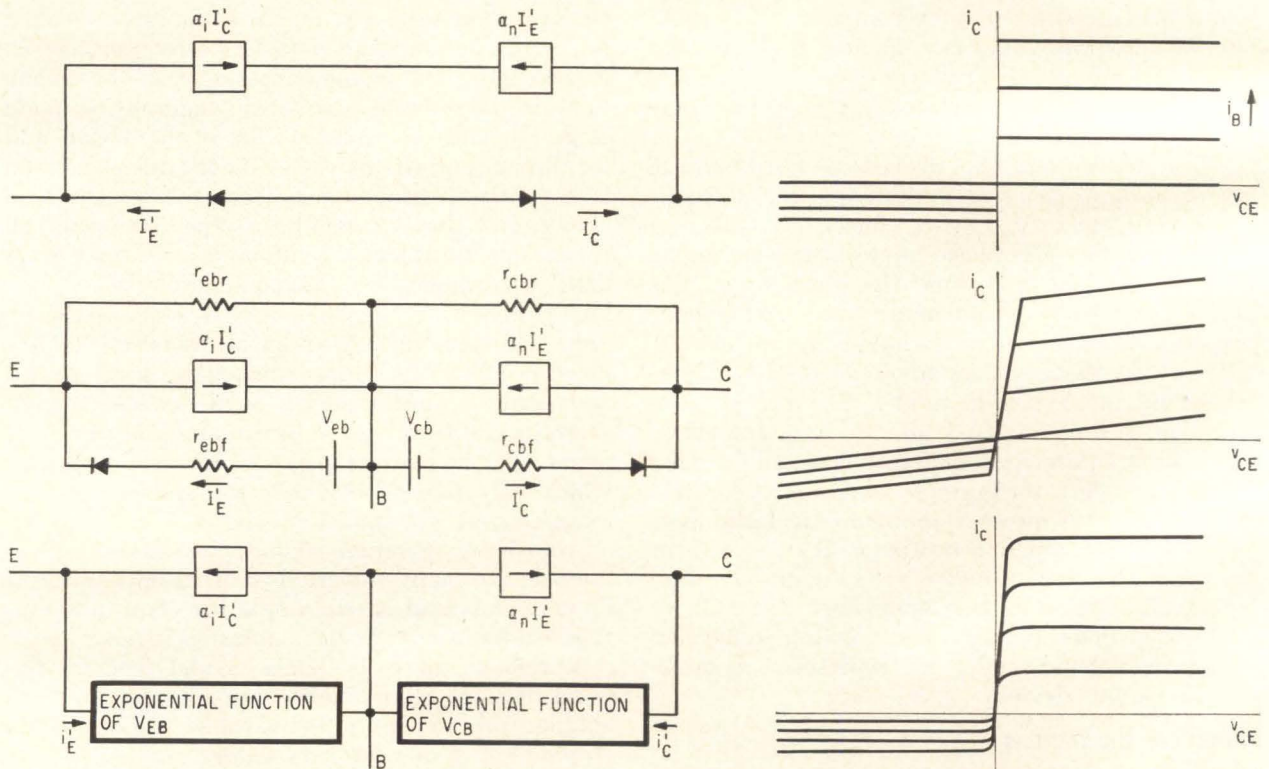

Piecewise-linear models are used to simulate nonlinear d-c problems. The top circuit is the basic model with a current-versus-voltage curve representing ideal conditions. An improved model is shown in the center; its curves are more realistic than the top model. The most accurate d-c model is the Ebers-Moll circuit at the bottom. Its prime limitation, however, is that it will not run on ECAP, because this program does not accept exponential functions.

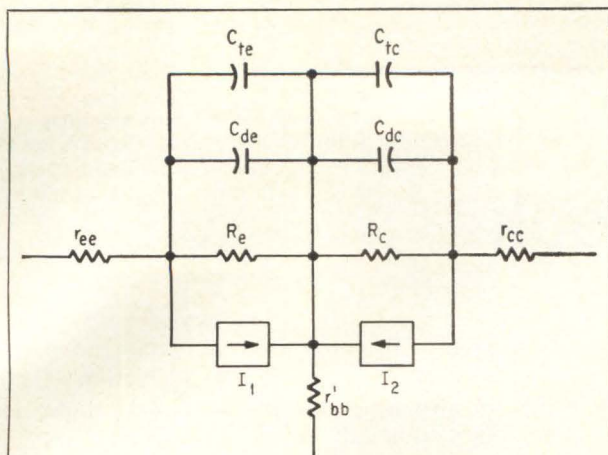

Nonlinear transient problems of transistors are best represented by this common-base circuit.

$$I_1 = i_{E'} - \alpha_i i_{C'}$$

$$I_2 = i_{C'} - \alpha_n i_{E'}$$

$$C_{de} = \frac{q(I_{ES} e^{qV_{EB}/kT})}{2\pi m_e kTB_n}$$

$$C_{dc} = \frac{q(I_{CS} e^{qV_{CB}/kT})}{2\pi m_c kTB_i}$$

$$C_{te} = \frac{U_1}{(V_{oc} - V_{EB})^{\gamma_e}}$$

$$C_{tc} = \frac{U_2}{(V_{oc} - V_{CB})^{\gamma_c}}$$

where

- q = charge of an electron
- k = Boltzmann constant
- T = absolute temperature of the junction
- V_{CB} = collector-base junction voltage
- V_{EB} = emitter-base junction voltage
- V_{oc} = emitter-base junction contact potential
- V_{oc} = collector-base junction contact potential
- I_{ES} = emitter-diode reverse saturation current
- I_{CS} = collector-diode reverse saturation current
- m_e = emission constant for emitter
- m_c = emission constant for collector
- γ_e = emitter-base grading constant
- γ_c = collector-base grading constant
- B_n = proportionality constant determined empirically
- B_i = proportionality constant determined empirically
- U_1 = proportionality constant determined empirically
- U_2 = proportionality constant determined empirically

sient modeling. It includes resistors, inductors, capacitors, dependent current sources and a very flexible ideal switch capability. The switch function can be made to alter the value of R's, L's, C's or dependent sources when chosen currents reach predetermined values. This permits the programmer to use piecewise-linear models that include changing resistances and energy storage elements. The program has separate d-c, a-c and transient analysis routines, all of which apply a highly user-oriented input language.

The accuracy of piecewise-linear transient models in ECAP depends on the ingenuity and labor that the programmer puts into his model development, but no amount of either will yield the accuracy of

NET-1 for junction-transistor and diode-circuit analysis. On the other hand, NET-1 lacks ECAP's flexibility of model choices and must use a complex model to analyze such simple problems as the saturating logic circuit.

Storage time resists modeling

Some solid state phenomena are not easily modeled by conventional lumped (linear or nonlinear) network elements. Among these is the minority carrier storage time of ordinary diodes and transistors. This effect is easily represented in the Linvill lumped-diffusion model,⁶ though it's likely that adding elements that express relations between variables other than current and voltage will further improve the fidelity of solid state models for computers.

Another function of the computer is to store semiconductor parameter values. Designers often build equipment with semiconductors that perform at values not readily available in manufacturers' data sheets. At the same time, a collector of adequate data sheets would be enormous and impractical. By storing parameter information from transistor models in the computer, the designer need only feed in specifications for a circuit and have the machine tell him which semiconductors are best suited to his purposes.

As noted earlier, choosing an optimum single device model for a general-purpose program is just about impossible at present. It might eventually be possible to add to a flexible program like ECAP a preprogrammed set of models ranging from the simple to the quite elaborate. It's conceivable that such a multiple model would make automatic provision for changing to a more accurate version when collector voltage dropped to near saturation or rose toward breakdown. Also, future advances in user-oriented circuit analysis and design programs are certain to render many of these conclusions concerning multiple applications irrelevant.

References

1. R.D. Middlebrook, "An Introduction to Junction Transistor Theory," John Wiley & Sons Inc., 1957, p. 242.
2. R.P. Nanavati, "An Introduction to Semiconductor Electronics," McGraw-Hill Book Co., 1963, p. 246.
3. J.J. Ebers and J.L. Moll, "Large-Signal Behavior of Junction Transistors," Proceedings of the Institute of Radio Engineers, Dec. 1954, Vol. 42, pp. 1761-1772.
4. A.F. Malmberg, F.L. Cornwell and F.N. Hofer, "NET-1 Network Analysis Program," Report No. LA-3119, Los Alamos Scientific Laboratory, 7090/94 version, August 1964.
5. "1620 Electronic Circuit Analysis Program 1620-EE-02X Users Manual," International Business Machines Corp., Technical Publications Dept., 1965.
6. John G. Linvill, "Models of Transistors and Diodes," McGraw-Hill Book Co., 1963.

Bibliography

- H.J. Zimmerman and S.J. Mason, "Electronic Circuit Theory," John Wiley & Sons Inc., 1959.
- A.T. Cote Jr. and J.B. Oakes, "Linear-Vacuum-Tube and Transistor Circuits," McGraw-Hill Book Co., 1961, p. 81.
- V. Joyce and K. Clarke, "Transistor Circuit Analysis," Addison-Wesley Publishing Co., 1961, p. 231.
- P.E. Gray, et al, "Physical Electronics and Circuit Models, SEEC 2," John Wiley & Sons Inc., 1964.

Designer's casebook

Designer's casebook is a regular feature in Electronics. Readers are invited to submit novel circuit ideas, packaging schemes, or other unusual solutions to design problems. Descriptions should be short. We'll pay \$50 for each item published.

Polarized light triggers remote control system

By E.K. Howell,

Semiconductor Products Department,
General Electric Co., Auburn, N.Y.

A polarized light source more than 50 feet away can actuate a remote control system with little fear of the system being triggered accidentally. Since the polarized light is easily produced and conveniently directed, the source need not be fixed. For example, a signal from a moving vehicle can reach into visible, yet inaccessible places to trigger safety devices, garage doors or overhead hoists. Polarization permits selection of a single target from a group of controls while immunizing the system from background light or "noise."

For short-range work, there is little problem in differentiating between the desired light signal and the background light. At longer distances and in uncontrolled-light environments, however, the ratio

of signal to noise becomes very small, requiring additional steps to achieve detection.

In this system, the controlling light source is polarized in a vertical plane by a filter. The receiver is a dual-element photocell with one section covered by a horizontal polarizing filter and the other by a vertical polarizing filter. The control circuit responds only if the output signal from the dual photocell indicates the presence of excess light polarized in the vertical plane.

The control circuit operates from a 24-volt a-c source. Rectifiers D_1 and D_2 respectively provide the negative and positive d-c supply voltages; both voltages are regulated by zener diodes. Terminals A and C of the dual-element photocell connect to the negative and positive supply voltages, while center terminal B is wired to the gate of the silicon controlled rectifier, SCR_1 . If the negative and positive sections of the photocell are identical, nonpolarized light will produce equal resistances in each section; hence the potential at terminal B remains at zero.

If there is an excess of horizontally polarized light, the resistance between terminals A and B decreases; thus the potential at terminal B will be negative and will have no effect on SCR_1 . An excess of vertically polarized light decreases the resistance

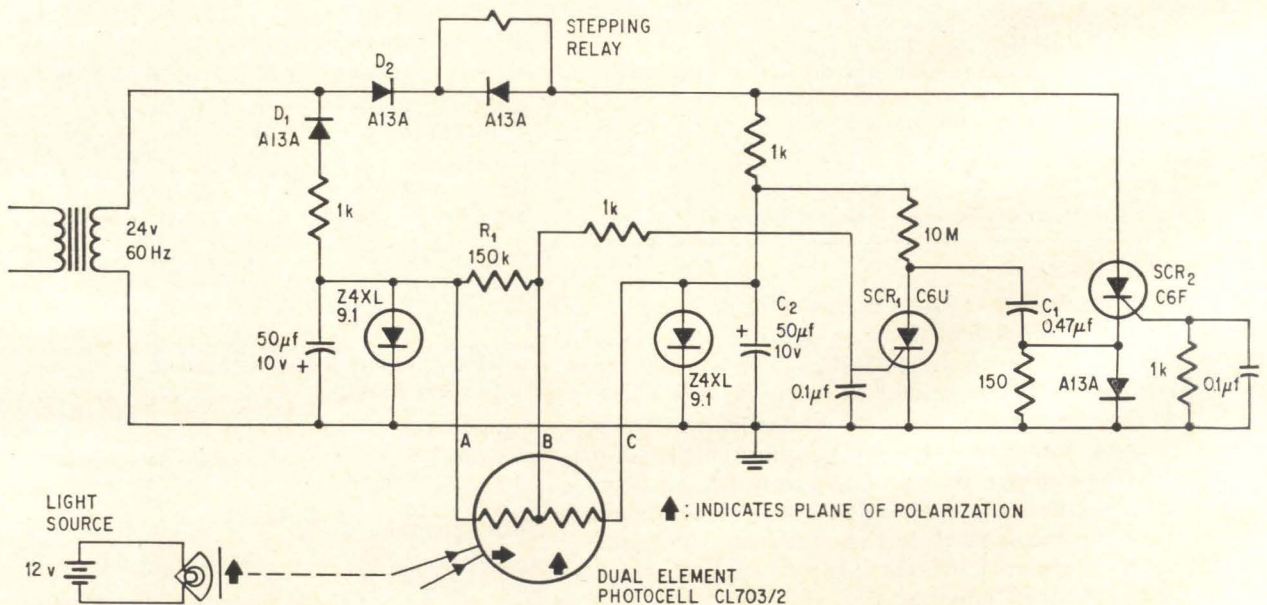

Vertically polarized light lowers the resistance between terminals B and C, making B positive and firing SCR_1 . Capacitor C_1 discharges and turns on SCR_2 ; the current through SCR_2 energizes the stepping relay.

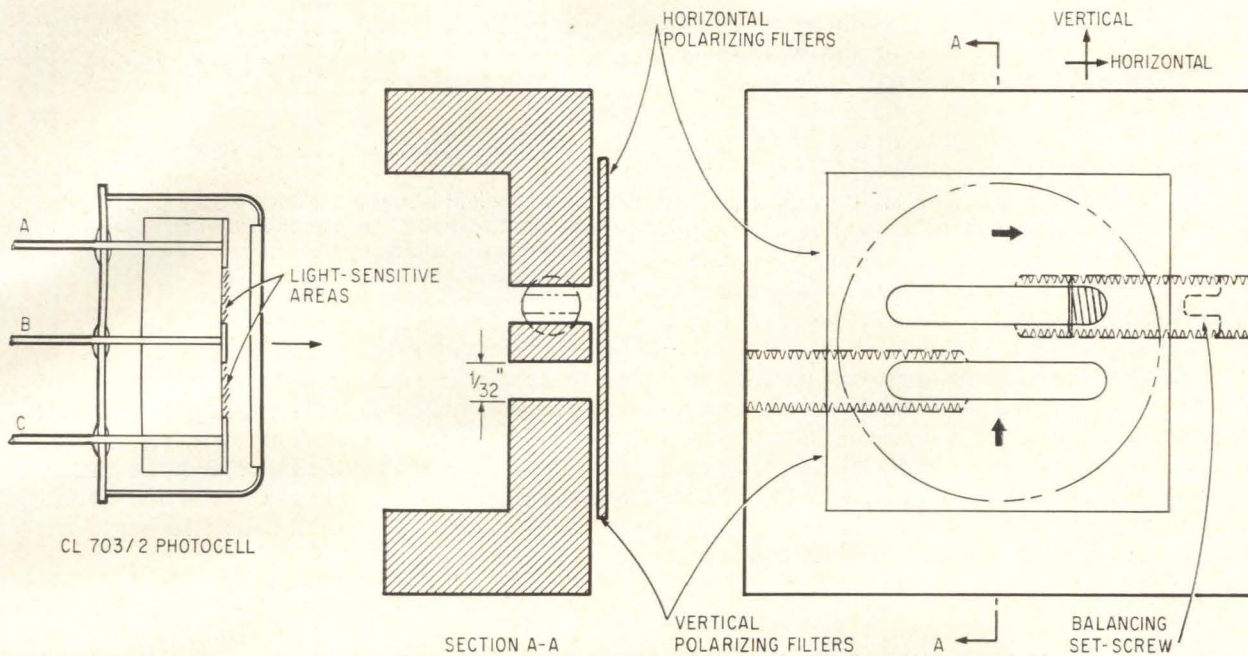

Slot dimensions in the aperture block narrow the angle of view to minimize the chance of noise accidentally triggering the device. Top and bottom slots are covered with horizontal and vertical polarizing filters respectively. The set screw compensates for imbalances in the photocell and the supply voltage circuitry by reducing the size of the light-sensitive area exposed.

between B and C, making B positive, and triggering SCR₁ when potential reaches 0.6 volt.

As SCR₁ fires, it discharges capacitor C₁, producing a negative pulse on the cathode of SCR₂, which turns it on. With SCR₂ on, current conducts through the stepping relay coil, and capacitor C₂ discharges. The discharge current holds SCR₂ in conduction for several cycles, giving time for the stepping relay to operate sequentially in controlling a motor. The first flash of light causes the relay to turn off the motor; the second flash causes the relay to turn on the motor in the reverse direction; the third flash causes the relay to turn off the motor; the fourth flash causes the relay to turn on the motor in the forward direction. The discharge of C₂ also produces a negative signal at the gate of SCR₁, turning it off. If light is still present on the vertically polarized section of the photocell at the end of SCR₂'s conduction, SCR₁ will fire again before capacitor C₁ has time to charge. When SCR₁ conducts, however, it shorts out capacitor C₁, preventing a second pulse from triggering SCR₂ until no light hits the photocell for approximately 2 seconds.

To further improve the signal-to-noise ratio, the aperture block limits the view to a narrow rectangular area. The two slots in the aperture match the two sensitive areas of the dual-element photocell. The slots are deep enough so that light coming through one slot cannot strike the sensitive area beneath the other slot regardless of the angle of

incidence. The angle, size and spacing of the two slots make it highly improbable that any light source or shadow will activate the system without proper polarization. The diagram shows the spatial response of the apertures in both planes.

In the laboratory, the lamp, components and aperture illustrated operated effectively at 51 feet under normal ambient lighting conditions. For best operation, the photocell should be positioned so that its viewing area does not include predominant sources of interfering light.

The immunity of the control system to non-

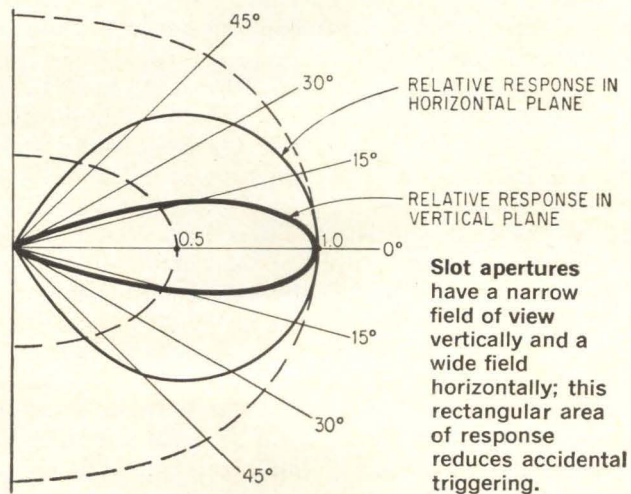

polarized light depends upon the quality of the positive and negative supply voltages and upon the balance of characteristics of the two sections of the photocell. Given normal component tolerances, some means of balancing the system is necessary. The best method is a mechanical shutter to control available light allowed to strike either section of the photocell. The shutter changes the length of the aperture slot; the width and depth spacing of the slot remains constant. A small set-screw at the end of the slot will suffice. The adjustment should be made in the presence of a high level of nonpolarized light.

At low-light levels, a resistor R_1 in parallel with the negative half of the photocell produces a negative signal on the gate of SCR_1 , preventing accidental triggering of the photocell in the dark. Additional photocells may be connected in parallel to facilitate operation from different locations.

The remote control system's portable light source

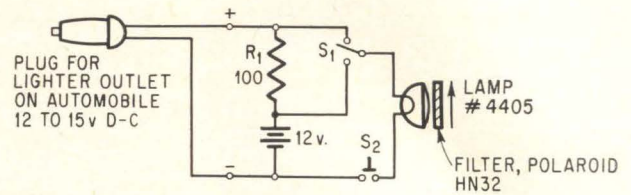

Portable spotlight is masked with a vertical polarizing filter. Power can be supplied from an automobile cigarette lighter outlet or from rechargeable nickel-cadmium batteries.

operates from 10 nickel-cadmium batteries that can be recharged from a cigarette lighter outlet in an automobile. Switch S_2 is a toggle or pushbutton switch that operates the lamp; switch S_1 provides the option of operating the lamp from the batteries or from the charger source and can be incorporated in the plug. Resistor R_1 limits the charging current to an appropriate value.

Differential Schmitt trigger with 200-k input impedance

By Gilbert Marosi

General Precision Equipment Corp.
Link Group, Sunnyvale, Calif.

Input impedance of the three-transistor differential Schmitt trigger circuit shown is 200 times greater than that of a conventional Schmitt trigger. High input impedance, essential for squaring up low-power information signals, normally requires an additional transistor. In addition, the circuit's trip points and hysteresis remain stable over a wide temperature range and can be predicted.

The differential pair of transistors, Q_1 and Q_2 , form a constant-current mode switch controlling output transistor Q_3 . Transistor Q_2 is normally on and maintains Q_3 on by supplying Q_3 with 1 milliampere of base current. With Q_2 on, the output is at -20 volts and diode D_2 is back biased so hysteresis resistor R_3 is out of the circuit.

Bias resistors R_1 and R_2 fix a reference voltage at the base of Q_2 . The reference voltage exactly determines the turn on point of the circuit. Since Q_1 and Q_2 are identical and their emitters are at the same potential, an input voltage at the base of Q_1 equal to or more negative than the reference voltage at the base of Q_2 turns on Q_1 . With Q_1 on, Q_3 turns off.

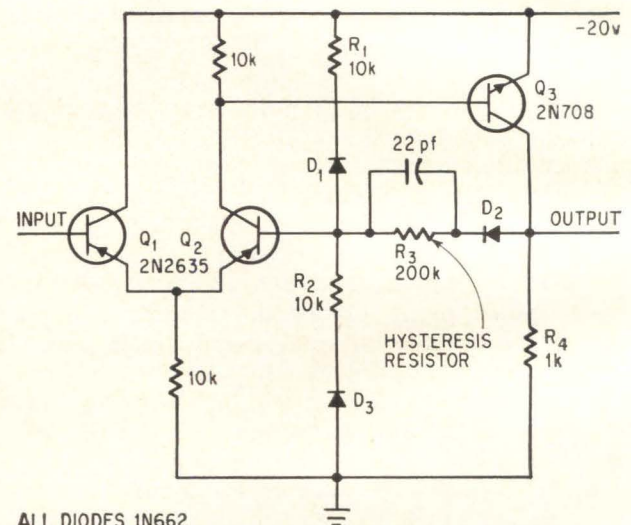

ALL DIODES 1N662

Transistors Q_1 and Q_2 form a current mode switch controlling output transistor Q_3 .

When Q_3 turns off, the output drops to ground, forward biasing diode D_2 . Now that D_2 is conducting, hysteresis resistor R_3 is again part of the circuit, and provides another path to ground from the base of Q_2 , bringing it closer to ground by approximately 0.5 volt—the hysteresis voltage. The hysteresis draws Q_2 even farther into the non-conducting region; this action assures a latching turn off for Q_3 and prepares Q_3 for fast turn on—typically 15 nanoseconds. The speed of Q_3 is the circuit speed, since the current mode switch Q_1 and Q_2 , introduces only negligible delay.

The input signal drops below the new voltage at the base of Q_2 , the original reference voltage as adjusted by the hysteresis. As soon as this happens, Q_1 turns off, allowing Q_2 to turn on. With Q_2 conducting, Q_3 turns on and the output voltage jumps to -20 volts. Diode D_2 is back biased, R_3 is disconnected from the circuit, the

triggering cycle is complete and the circuit is ready for the next input.

The circuit's input impedance is at least 200 kilohms, assuming a current gain of 20 for Q_1 . The hysteresis and the turn-on and turn-off points are not dependent on temperature changes because of the compensation from the diodes.

Low voltage supply produces good regulation at low cost

By Ernest Luttrell

Texscan Corp., Indianapolis, Ind.

A well regulated, low-voltage power supply can be built for \$7 by incorporating a zener diode in the regulator to boost the operating voltage of the amplifier that detects voltage differences.

For a high impedance voltmeter, a -2.7 -volt d-c supply is required as a replacement for a mercury cell. It has to have less than 100 microvolts root-mean-square noise and ripple and no detectable low-frequency jitter. Line regulation of 0.01% and load regulation of 1% are required. The circuit shown below fits the need.

Transistor Q_2 is controlled by emitter-follower Q_1 and common-emitter amplifier Q_3 . Transistor Q_3 is the difference amplifier. It produces a current proportional to the voltage difference between the output potentiometer arm and reference diode, D_3 .

Zener diode D_2 insures that Q_3 has sufficient voltage to operate properly. Diode D_2 holds the

base of Q_1 at about 7 volts and places 10 volts across the combination of D_3 and the collector of Q_3 . Since the voltage across Q_3 should be as high as possible, the barrier potential of an ordinary diode D_3 , instead of a zener, serves as the reference voltage. Diode D_3 has lower impedance and produces less noise than a low voltage zener.

If D_2 were omitted, the base of Q_1 would only be about 1.4 volts above ground. This would leave about 4.1 volts across the combination of Q_3 and D_3 —a voltage too low for proper operation of Q_3 .

Forward-biased diode D_4 , which serves as a variable potential divider in the base of Q_3 , compensates for temperature variations in D_3 and the rest of the power supply. Diodes D_4 and D_3 are similar types, and they vary with temperature at about the same rate. The value of R_3 is specially selected to control the magnitude of the impedance change of D_4 .

To improve line voltage regulation and reduce ripple, resistor R_1 and diode D_1 establish a constant voltage source at the junction with R_2 . This reduces a possible source of current variation in Q_1 's base current and makes Q_1 less susceptible to input line variations. It is sometimes desirable to add a large electrolytic capacitor across zener diode D_1 to reduce the low-frequency noise in this element.

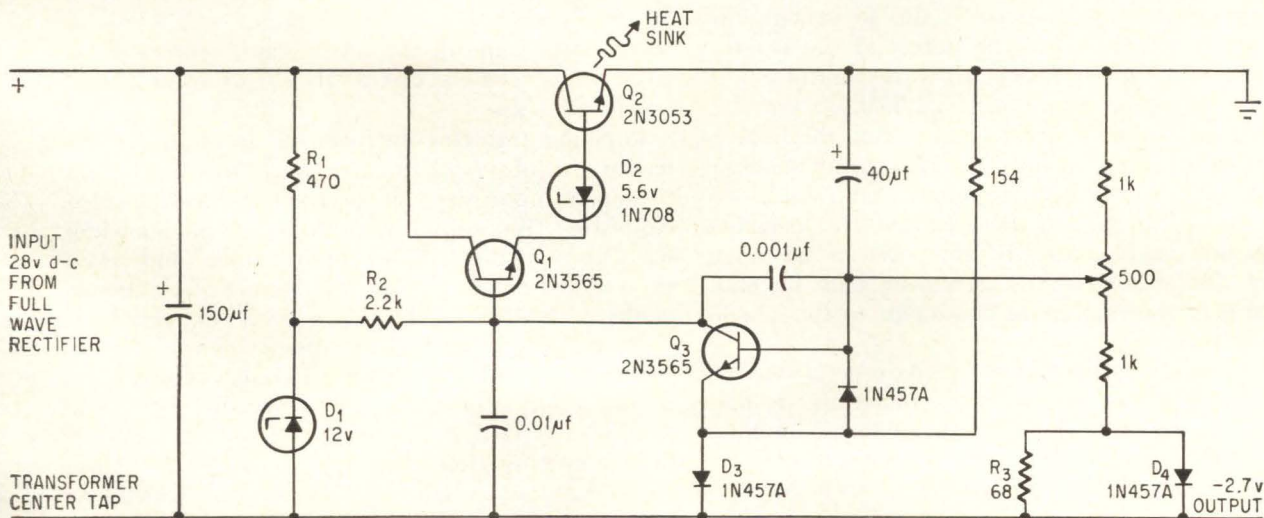

Zener diode D_2 provides amplifier Q_3 with the proper operating voltage. Reference voltage is established with a common diode, D_3 , instead of a zener diode since the zener would produce a larger voltage drop.

Integrated circuits in action: part 4

Postmortems prevent future failures

Weeding out defective IC's is just the first step
in assuring reliability; IC pathologists dissect failed circuits
to pin down failure causes and prevent future design and processing mistakes

By Seymour Schwartz

National Aeronautics and Space Administration,
Electronic Research Center, Cambridge, Mass.

Bad integrated circuits are more valuable than good ones to the failure analyst. It is his objective to perform a postmortem, then feed his findings to equipment or device designer. If improper use killed the IC, the equipment designer must rework the design or select a different IC. If poor design or fabrication of the IC itself caused its demise, the device manufacturer takes the blame and must find the cause.

Objectivity is the hallmark of the failure analyst. His aids are analytical tools ranging from simple voltage probes to electron microprobes costing about \$100,000. His knowledge must encompass both materials and manufacturing methods.

To understand what caused the IC to fail, the analyst must first isolate the defect of the IC—the failure mode. Once he recognizes the failure mode, such as an open circuit or high leakage current, the analyst can often guess what caused the failure. But he must keep an open mind. Further analysis confirms or rejects his suspicions and pins down the underlying process that caused the defect—the failure mechanism. In the case of an open circuit, for example, the mechanism may be poor bonding of the aluminum conductor to the silicon substrate.

At times the analyst must compare good devices with bad, or examine starting materials to find anomalies that could influence behavior of the final IC. And from time to time he may have to deliberately cause failures in otherwise good devices to check a hypothesis.

An intimate knowledge of how failure mechanisms match failure modes is indispensable in attempting an analysis, since testing for the wrong

fault can sometimes mask the real defect.

Let's follow the step-by-step analysis that disclosed the cause of a typical defect in IC's. The case is a classic, involving IC's for the Minuteman 2 program.

Detective story

Apparently, the thermocompression bonds between the gold interconnecting wire and the aluminum on the IC dice had a tendency to open. Once the IC package lid was removed, it was easy to recognize the completely open bonds. However, there was a catch. The bonds were permanently open in some devices and intermittently open in others. Furthermore, the intermittent ones were not found until some of the open bonds were seen to close when a static electrical charge accumulated on the IC's case.

Pursuing this clue further, the intermittent behavior was observed to occur fairly frequently and to depend upon the voltage applied during electrical testing. To complicate matters, the phenomenon was also influenced by temperature and even showed some time dependency. Some of the bonds could be made to behave intermittently almost at will, making them act as a mechanical on-off switch.

But it was still impossible to predict which good bonds would open from just electrically testing the IC's. The IC had to be subjected to a physics-of-failure investigation to determine the actual cause.

Both good and bad bonds in the same device as well as in other similar devices were subjected to metallographic examinations. Standard metallographic preparation procedures were used to cross-section and polish the bonds, enabling them to be

viewed more clearly. Special etching techniques revealed the microstructure of the bonds. Photomicrographs of these polished bonds were then made.

The metallographic work showed that the thermo-compression bond failures were probably associated with intermetallic compounds appearing in a band between the gold lead wire and the aluminum thin-film terminal on the IC chip. Even though the bond's constitution was considered to be a single-phased, aluminum-rich region, various aluminum etching reagents did not attack the intermetallic band. This lack of etching suggested that the band was probably composed of gold-rich phases.

Thorough microscopic examination of open and intermittently open bonds showed a crack, void or discontinuity of some kind at the outer edges. The location of the discontinuity was an additional indication that the band was a multiphase structure. A suitable etching reagent was developed to define the new structure. The information obtained from this extensive micrographic examination of polished and etched bond cross sections enabled a failure mechanism to be postulated—the interdiffusion of the gold and aluminum and a tendency to form gold rich intermetallic compounds at high temperatures.

Other techniques were then used to support and clarify the previous conclusions. Several gold-aluminum compositions were made to provide metallic and phase identification. X-ray diffraction and electron beam microprobe techniques determined the composition of the various microconstituents observed in the compositions as well as those in the intermetallic band. Thus the various phases making up the intermetallic were identified, within the limits of accuracy and resolution of the equipment available.

As in many failure investigations, the corrective action to prevent the failure from recurring was the most important product. In this case, the prescription was a third metal between the gold and aluminum. Deposited on the aluminum it acts as a diffusion barrier and prevents the gold-rich compounds from forming. As another solution, aluminum instead of gold wires can be used.

Tools of the trade

Failure analysis laboratories can range in size from little more than a home workshop, with only basic measuring instruments, to something like research facilities, with such sophisticated instruments as the scanning electron microscope. The equipment depends on the type of tests to be performed and these fall into three categories:

- Size and shape (physical damage)
- Material defects (deterioration or inferior materials)
- Contamination (including contamination resulting from leaks)

Tools for the first type of analysis include microscopy, radiography and film thickness measurements; the second includes electrical characteristics

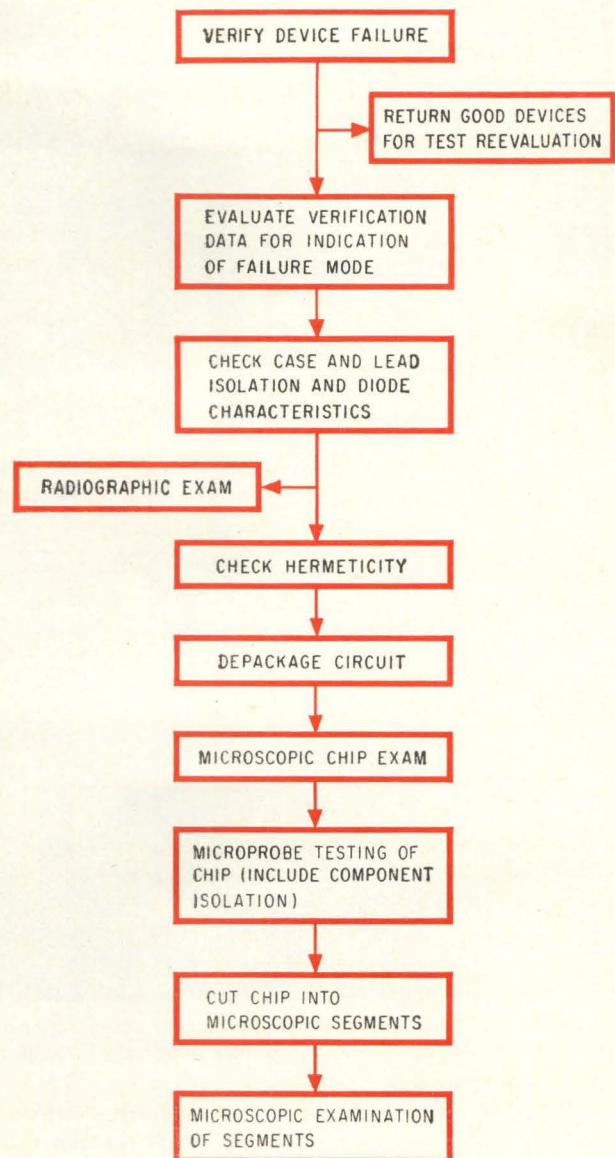

General procedure for failure analysis of monolithic IC's begins with a verification of failure modes. Analysis ends at which ever step the failure mechanism is found.

and thermal behavior measurements, metallographic and crystallographic examinations, chemical analysis and mechanical strength tests; the third category covers chemical and physical examinations.

The best-equipped failure analysis laboratories are usually those of IC manufacturers. But companies such as the Raytheon Co. and the Autonics division of North American Aviation Inc. use IC's in sufficient volume to warrant fully equipped failure analysis laboratories. Government facilities such as the Rome Air Development Center, N.Y. and the National Aeronautics and Space Administration's Electronic Research Center, Cambridge, Mass. are also equipped to handle failure analysis.

Among the basic gear necessary for failure analysis are microscopes capable of magnifying at least 500 times, photographic accessories, chip probes, power supplies, curve tracers and a variety of

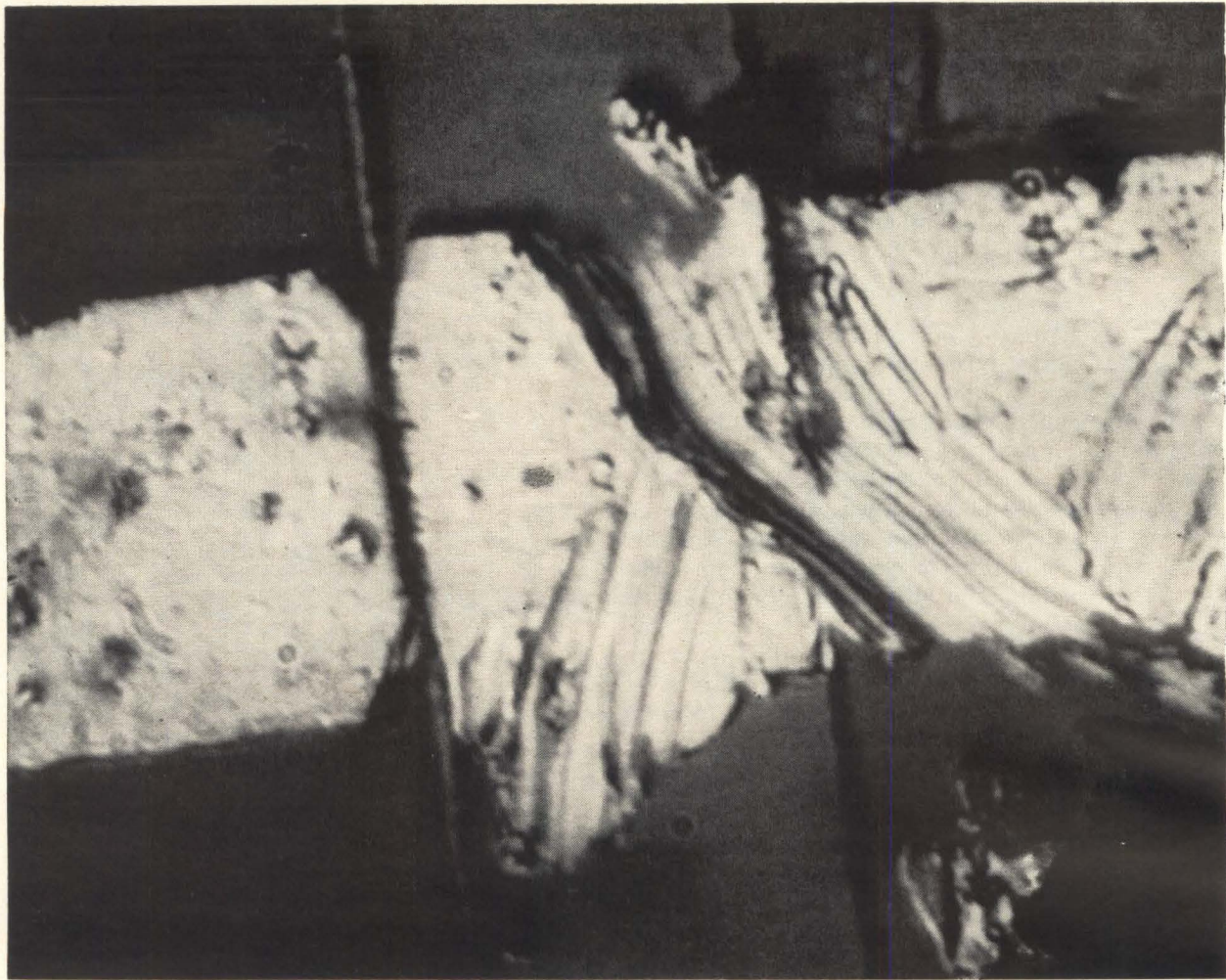

Scratched aluminum intraconnection can lead to an open circuit. The thinner conducting area has a reduced current capacity and therefore may burn through during operation.

meters. Most users will depend on an outside laboratory or the manufacturer for such specialized services as radiography. With only the basic tools, however, the user can verify the electrical tests the IC initially failed, evaluate the data for an indication of failure mode and narrow the probable cause of the failure. He can check case and lead isolation and diode characteristics, verify the hermetic seal and examine the chip with microscopes and microprobes. If desired, the user can even cut the IC into microscopic sections and examine each in detail, including its cross sections.

Sequence important

Searching for failure mechanisms often requires techniques that are destructive to the IC and the sequence of operations should be carefully set up so that one test does not destroy a failure mechanism that might be found in subsequent techniques. Basically, there are two types of tests: destructive and nondestructive. Opening a device's package to look inside or stressing it to failure destroys the device; testing it under extreme conditions and environments accelerates failure mechanisms and may result in a less reliable device. Nondestructive tests, however, are usually limited in scope, but obviously

the nondestructive tests should be made first.

It is usually wise to begin the search for failure mechanisms by retesting the IC that failed to confirm its failure mode. Next the lead and case isolation of the IC are checked as well as its diode characteristics, that is, its pin-to-pin input-output characteristics. At this point the tests are limited to electrical screening, visual or microscopic examination of the exterior of the device and chemical analysis of removable contaminants.

Radiography also may uncover a reason for a failure without disturbing the parts internally; for example, open or missing wires between the circuit and header can be seen with X-rays. If radiography reveals no faults, the package is checked for leaks through which moisture and other contaminants may have entered, causing corrosion and shorts.

Infrared is a promising nondestructive tool, but still needs further development. Infrared thermographs reveal the thermal condition of an IC and it follows, therefore, that its greatest potential is in discovering sources of thermally-induced failures.

After the nondestructive tests are completed, the can is opened and the circuit is exposed. Now detailed microscopic examination is possible and the

chip can even be cross-sectioned to detect minute structural defects.

Immediately evident are failure mechanisms like open bonds, large voids in the bond between the back of the silicon chip and the package base or missing parts. But too often direct evidence of the cause is destroyed by the failure itself. Then one must postulate failure mechanisms and test sample ic's with design variances that reproduce the hypothesized failures.

Forced failures

Intentional failures in integrated circuits sometimes are induced with the same equipment used to test them. Among gear that can stress circuits to failure are wet and dry ovens, cooling baths, centrifuges, impact testers, vibrators, pressure vessels and electrical power sources.

The ovens serve a dual purpose. Storing ic's at high temperatures accelerates material interactions that lead to failure, such as a breakdown in the insulating films. The high temperature also causes differential thermal expansion leading to mechanical faults such as open thermocompression bonds.

Plunging the hermetically sealed ic into a cooling bath condenses any vapor trapped in the package. If moisture is present, it can cause corrosion, short circuits and radically change the device's performance.

Alternately heating a circuit in an oven and cooling it in a bath produces still another stress—thermal shock. As the circuit experiences heat and then cold, temperature gradients are established between materials with different thermal expansion coefficients, producing more stress. Such repeated thermal cycling often causes cracks in the substrate. Even if it does not produce an immediate failure, the cycling can cause the circuit to suffer a catastrophe from repeated plastic flow of the material bonding the ic to its header or heat sink.

Electrical stressing

Parts of the ic can be heated by electrically loading it in a manner logically related to in-use failures. Test loading is done either at rated capacity in hotter and hotter environments, or in a constant temperature at successively higher overloads.

During life testing, the electrical stress is applied at a fixed level until failures occur or the specified end-of-life is reached. In another type of electrical test, voltage or current stress is increased step by step until failures occur. Accelerated testing—testing at higher than design stress levels—has detected weaknesses that might not be obvious in ic's tested at normal operating conditions.

Although the failures experienced under the accelerated conditions may be related to those that would occur at normal operating conditions, the relation may be complex. For this reason, extrapolating the results of the accelerated tests to actual operating conditions may lead to erroneous answers. For instance, some mechanisms cannot be accelerated and, are more apt to occur under normal

What price reliability?

The ic user can gear up for failure analysis at a relatively modest investment or he can spend a fortune. The simpler equipment, such as binocular microscopes, may cost as little as \$100, while more exotic instruments such as an electron microprobe may run as much as \$100,000. Here's a thumbnail guide to equipment costs, subdivided according to the type of test the gear performs:

Instrument	Typical price or range (dollars)
Physical	
Optical microscope	100-1,700
Electron microscope	30,000-50,000
Interferometer	500-1,700
Profilometer	8,000-10,000
Electron diffraction microscope	30,000
Spectroscope	10,000-40,000
Electron microprobe	100,000
Scanning electron microscope	35,000
X-ray diffraction equipment	12,000-15,000
Tensile tester	25,000
Strain guage	100
Electrical	
Oscilloscope	1,000-2,000
Curve tracer	1,000-2,000
Meters, capacitance and inductance bridges	20,000-25,000
Chemical	
Absorption spectroscope	5,000-8,000
Emission spectroscope	10,000-13,000
Mass spectroscope	27,000-40,000
Thermal	
Thermal plotter	4,000

conditions than indicated by the accelerated tests.

Failures such as corrosion often are caused by moisture and other contaminants that enter the ic package through cracks and pores. Leak testing of ic's requires separate methods for detecting gross leaks and small leaks.

The smallest readily detectable leak (about 10^{-10} atmosphere-cc per second of helium at a pressure differential of one atmosphere) can be found by two methods: the first depends on the detection of radioactive gas, such as krypton 85, which is forced through the leak into the package; in the other method, helium is the tracer gas and a mass spectrograph detects it as it flows through the leak. In either method, the tracer gas may leak out of the package undetected if the leak is larger than about 10^{-5} atmosphere-cc per second. If the operation is performed quickly, the radioactive tracer method can detect leaks as large as 10^{-3} atmosphere-cc per second.

For larger, or gross leaks the part is immersed in liquid and heated or subjected to a vacuum. Bubbles are noted as the inside gas expands through the leak. Usually, leak testing is performed first, to weed out badly packaged ic's before the more exacting tests are performed.

Sometimes, electrical tests made inside the can

Through the electron microscope



Transmission electron micrograph shows both a triangular and linear defect in the base region of a device. Such defects can lead to shorts or opens, or even cause parameters to drift. The device is magnified 5,000 times.

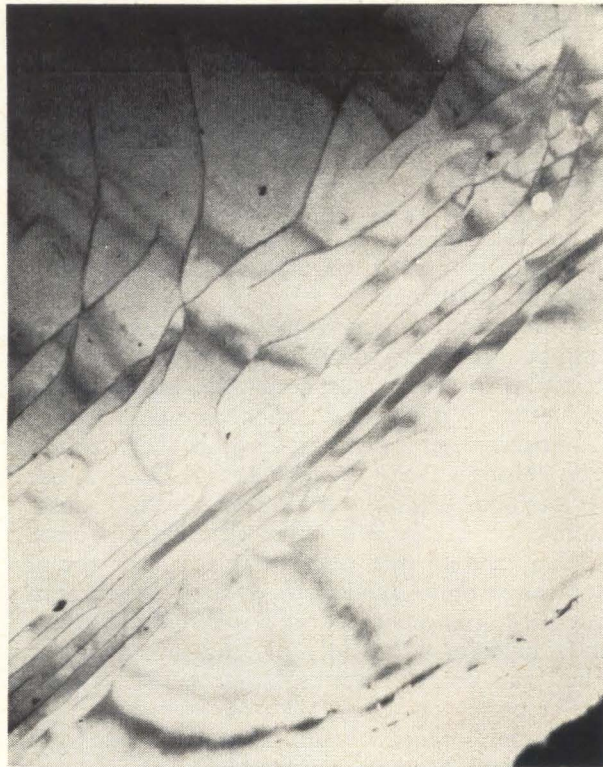

Dislocation structure, discontinuities on surface, are shown magnified with an electron microscope. The dislocation is at the surface of a power transistor near the junction region. Such a fault could lead to a soft junction and to abnormal electrical properties in the IC.

are more helpful than those made outside. Surface charge migration, contamination and surface leakage, for example, can be identified by studying on the die itself the minute changes in a device's secondary electrical properties that accompany failure. These properties include leakage current, capacitance and resistance.¹

Individual tests

Often the user will test IC's with instruments that run through a sequence of tests and provide readout on a digital voltmeter or punched tape. But failure analysis is concerned with individual testing and detailed probing of a device with pin-like contacts applied to the contacts or wiring on the IC chip. In these cases, IC voltage and current are often measured on an oscilloscope. Currents and voltages smaller than 1 nanoampere and 50 microvolts respectively, however, are read on static meters that have sensitivities as low as 0.003 picoampere or 2 nanovolts.

Resistance may be measured from 10^{-5} ohms to 10^{15} ohms or to resistivities as high as 10^{19} ohm-centimeters. Capacitance bridges are available to measure from 10^{-17} to 1 farad, and induction bridges can measure from 10^{-10} to 10,000 henries.

Voltage probes may consist simply of two wires if contact pads are provided within the IC and contact potentials and thermal effects are taken into account. For voltage mapping—measuring the distribution of electric fields across a sample—a more general technique is available: electron beam sensing with a scanning electron microscope. Mapping the electric field across an IC shows any large voltage gradients and warns of a potential trouble spot. For example, a sharp corner on a resistor could result in a large field gradient, which could eventually short through the insulating layer.

Once the device is opened, many failures are apparent to the eye, such as discoloration or breakage of miniature device parts. Magnification up to 100 times with a binocular microscope more clearly reveals gross mechanical damage, chemical corrosion or discolorations resulting from overheating, poor registry of deposits and missing parts or materials. A vacuum-deposited aluminum intraconnection, for example, may have reduced current capacity because of scratches.

Some defects, such as pinholes in insulating films which can lead to shorts, may not be visible even under a microscope. To detect these, the die or chip must be removed from the package and the aluminum etched off the IC's surface. Chemical techniques and a low-power microscope can then be used to locate the pinholes without damaging the sound portions of the film. For example, three variations of electrolysis can show pinholes in silicon oxide.

- If no bare silicon is exposed, the sample acts as the cathode in a bath of methanol. Voltage through the bath produces a solution of silicon through the pinholes, forming a stream of bubbles.²
- Another method uses an anode material that

Instruments for failure analysis

Instrument	Abnormality observed (physical)	Related failure modes	Probable failure mechanisms
Dye penetrant	Cracks, pores	Leaks	Inversion (change in semiconductor type)
Etching and microscopy	Dislocation distribution Pits, cracks and chips Pinholes and cracks in oxide insulating layer	Soft junction (gradual rather than sharp increase in current characteristic across junction). Opens Shorts	A processing control
Binocular microscope (3-120X magnification)	Inhomogeneity (Oxidation, contamination, intermetallics or rub marks.) Opened bonds Cracked dice Cracks in package lead seals Pits and pyramids on dice Poor registry or masking Scratches on dice or intraconnects Microplasma in operating device	Weak bonds or electrical leakage Electrical open circuit Open circuit or shift in resistance Leaks High leakage or hot spots at thinner base areas High leakage, shorts or opens Open or high resistance Soft junction	Poor surface wetting Migration of charged contaminant causes inversion. Intermetallics form by diffusion. May have resulted from overheating. Mishandling, overheating or contaminated land surface. Pressure during die or lead bonding. Rough handling, misalignment, thermal mismatch or bubbles in glass. Poor epitaxial growth control results in thin localized base areas (after diffusion). Narrow insulating path may short, or inversion may cause high leakage current. Meager connection may open. Excess heat. Current concentrates at stacking faults, dislocations or thin spots in base.
Phase contrast microscope	Stacking faults Transparent contaminants Improper oxide metallization topography	Soft junctions Surface inversion Electrical leakage, shorts or opens	Shifting electrical parameters Ionic contaminants migrate and result in reverse leakage. Misalignment creates narrow insulating paths which short or leak as result of inversion. Meager contacts melt and open.
Dark field microscope	Photoresist residues, dust Bubbles in sealant glass	Inversion Leaks	Diffusion of charged contaminants Inversion
Interferometer	Oxide and surface topography varies from design Oxide thickness varies from design Metal thickness varies from design	Electrical leakage, shorts or opens Stray capacitance, electrical leakage or inversion Opens	Misalignment creates narrow insulating paths which short or leak as result of inversion. Meager contacts melt and open. Metal diffuses through oxide and causes leakage Thin metal areas burn out

Instrument	Abnormality observed (chemical)	Related failure modes	Probable failure mechanisms
Hot stage metallograph	Contaminant melting point and reactivity (for identification) Interdiffusion of metals, for example, Al-Au, Mo-Au, Ti-Au, Kovar-Au Whisker growth Grain growth Surface diffusion of metal films	Weak bonds or electrical leakage Parameter drift Shorts or opens Parameter drift Shorts, opens or parameter drift	Intermetallics form from diffusion. Metal whiskers grow and make shorts. Removal of metal leaves opens. Drift in braze, bond or interconnect resistance. Metal films cause shorts or inversion. Lack of diffusion barriers.
Electron diffraction	Contaminant crystal structure and identity and identity of intermetallic compounds Deposit crystallinity	Weak bonds or electrical leakage Open, shorts or parameter drift	
Low-energy electron diffraction Electron microprobe (elemental chemical analysis)	Presence of absorbed substances in surface Contaminant or rub mark residue identity and map. Dopant and dopant concentration Intermetallic analysis Corrosion product identity Deposit topography map by chemical element Deposit thickness map by chemical element Crack, pit and pinhole maps Junction misalignment or movement Opens, short and current and/or voltage nonuniformity map	Inversion Weak bonds or electrical leakage Related to process control Weak bonds or electrical leakage Weak bonds or electrical leakage Opens, shorts or parameter drift Opens Opens or shorts Electrical leakage, shorts, opens or inversion Abnormal electrical parameters	Migration of charged absorbates causes inversion. Migration of charged contaminants causes inversion. Thin areas melt and open. Thin or narrow areas on interconnects open. Pinholes. Migration of metal is evidence of inversion. Cause of abnormal electrical parameter may pinpoint failure mechanism.
Gas chromatograph	Abnormal package ambients Leaks (by presence of air or test fluid)	Inversion or gain drift Inversion or gain drift	Absorption, then charge migration causes inversion. Absorption, then charge migration causes inversion.
Mass spectrograph	Leaks. Also: reaction of device to ambient changes in the spectrograph	Inversion or gain drift	Absorption, then charge migration causes inversion.
Gas chromatograph and mass spectrograph in combination	Leaks. Also: reaction of device to ambient changes in the spectrograph	Inversion or gain drift	Absorption, then charge migration causes inversion.
Infrared absorption spectrograph	Thin oxide Abnormal oxygen content in silicon	Shorts or electrical leakage Drift	Abnormal electrical parameters. Recombination centers.

	metal thickness varies from design	Opens	Thin metal areas burn out
Electron microscope (magnifies to 100,000 X)	Dislocation and stacking faults distribution Contaminant and corrosion location Etch pits, scratches, dust and deposit roughness Pattern alignment and topology errors Undercut etched edges Weld porosity Porous diffusion products Scribe cracks	Soft junctions Weak bonds or electrical leakage Opens, shorts or parameter drift Shorts or opens Opens or inversion Contaminants Contaminants or weak bonds Opens (if cracks propagate)	Surface roughnesses cause thin spots in conductor deposits which may heat and melt. Meager contacts burn open. Narrow isolation areas short across. Contaminants cause corrosion and opens or migrate and cause inversion. Contaminates cause corrosion and opens or migrate and cause inversion. Contaminants cause corrosion and opens or migrate and cause inversion. Kirkendall effect (mismatched diffusion rates of dissimilar metals) causes voids. Thin spots may heat and melt. Thermal or mechanical stress causes cracks to propagate.
Radiographic equipment	Voids in welds Metal migration Contaminant particles Cracks Long wires Misalignment of metal parts	Leaks in package; opens if voids are associated with bonding of wires and package to IC die Shorts or opens Shorts Opens or leaks Shorts Leaks, opens or shorts	Inversion corrosion, poor welding control. Kirkendall voids form weak bonds. Mobile metallic contaminants short. Cracks propagate and open connections. Wires sag, cause shorts. Misalignment causes weak bonds, shorts, opens or leaky packages.
Controlled etching	Depth of inversion charge	Inversion	Inversion
X-ray diffraction	Identity of contaminant compounds or corrosion product compounds Identity of materials	Weak bonds or electrical leakage Abnormal electrical parameters	
Metallograph	Observes same abnormalities as binocular microscope; also: Poorly adherent interconnects or bond structures Abnormal junction depth (by angle lapping) Voids in thermo-compression bonds Incomplete or poor welds Thin or nonadherent plating	Opens Improper electrical characteristics Bond has high electrical and/or thermal resistance and may be mechanically weak Leak in package Poor joints	Improper deposition and/or bonding conditions. Bad junction depth. Hot spots, poor electrical characteristics or opens. Faulty package seals. Opens bonds and/or package leaks.
Electron back-scatter thickness meter	Thickness of oxide, plating or photo-resist	Stray capacitance, electrical leakage, inversion or opens	

	Abnormal epitaxy thickness Impure photoresist Water	Slow switching, punch-through Inversion Surface current leakage	Drift of marginal electrical parameters. Migration of impurities. Water vapor enters through leak.
Emission ultraviolet and visible spectrograph	Analysis and identity of contaminants	Parameter drift, opens, inversion	Contaminants migrate and change electrical properties or cause corrosion.
Visible and ultraviolet absorption spectrographs	Analysis and identity of contaminants	Parameter drift, opens, inversion	Contaminants migrate and change electrical properties or cause corrosion.
Neutron activation analyzer	Same as emission spectrograph but at lower concentrations	Parameter drift, opens, inversion	Contaminants migrate and change electrical properties or cause corrosion.
Instrument	Abnormality observed (mechanical)	Related failure modes	Probable failure mechanisms
Strain gauges	Loose headers or dice Poorly brazed headers or dice	Thermal Thermal	Nonadhesion of braze evident from thermal expansion of can. Poor thermal path causes overheating. Nonadhesion of braze evident from thermal expansion of can. Poor thermal path causes overheating.
Bubble tester	Gross leaks in packages	Channeling or inversion Opens or shorts	Nonadhesion of braze evident from thermal expansion of can. Poor thermal path causes overheating. Corrosion causes opens or shorts.
Helium leak tester or Radioflo tester	Small leaks	Uncontrolled package ambient causes inversion and corrosion	Charged adsorbates from ambient migrate and cause inversion. Corrosion by ambient causes opens or shorts.
Thermal plotter	Hot spots due to voids Hot spots due to thin base areas Hot spots due to dislocation or stacking faults	Thermal Thermal Thermal	Uneven diffusion and thin base areas. Faster diffusion along fault causes thin base area.
Instrument	Abnormality observed (electrical)	Related failure modes	Probable failure mechanisms
Curve tracer	Shorts Opens or intermittent contacts Soft junctions Abnormal resistance Leakage currents and inversion	Shorts Opens or intermittent contact Soft junctions Abnormal resistance Inversion	Sagging wire, punch through or surface creep of metal. Mishandling, intermetallic formation. Surface leakage. Mechanical damage or corrosion. Surface charge migration or surface contamination.

can be eroded in methanol. The voltage applied deposits anode material in the defective area—not necessarily a hole—and discolors it.²

▪ In yet another method, cracks and pinholes are revealed by chlorine gas that etches away silicon through the discontinuities in the oxide³ or by an amine-catechol etch.⁴

A print-out technique can identify bare silicon areas of a device. A microporous filter saturated with benzidine hydrochloride is pressed against the surface of the device. Where the silicon is exposed, either by design or through a pinhole, the colorless benzidine hydrochloride is oxidized and forms a black area on the filter.

Cracks and pores on the IC's wafer may also be detected by enhancing their visibility with dyes or stains. When a dye is applied to a surface and then wiped or rinsed off, the dye that penetrates a crack leaks back out and decorates the area of the crack or pinhole. An electrochemical technique known as chromate staining causes areas of different polarity to turn different shades of brown. The IC surface is covered with the stain and a voltage is applied to the die. Any crack or discontinuity is seen easily since it causes a sharp difference in surface potential and appears as a different shade of brown on the package. This method was first reported at the 1964 Physics of Failure Symposium.

Small irregularities in the surface of a device, such as those that are caused by contaminants, can be seen easily with dark-field and phase-contrast microscopes that depend on variations of illumination. Dark-field illumination is illumination from angles beyond those accepted by the microscope objective. The technique emphasizes rough spots, pits and scratches as well as steep, shallow steps on the device surface because these irregularities scatter light into the instrument's objective.

Phase-contrast microscopy consists of optically combining in the microscope one part of the illuminating light that is not reflected from the sample with reflected light from the sample surface, causing phase interference. Small variations in the length of the light path, caused by small variations in the height of the sample surface, result in destructive light interference and yield visible differences in shade or color.

Metallography

An instrument for investigating flaws in the surface of an IC is the metallograph, another special form of microscope. This instrument has an effective magnification of 2,000 with a resolution as fine as 0.5 micron. Besides showing up the kind of failure mechanisms seen through the binocular microscope, the metallograph can magnify cross sections of the IC die. In this way, failure mechanisms such as voids in thermocompression bonds, incomplete welds and thin or nonadhering plating can be seen.

A more flexible metallograph, the hot-stage metallograph, permits observation of changes in materials and devices at controlled temperatures up to 1,600°C. It can investigate failure mechanisms



Electron microprobe scan of lead and pad area on IC surface discloses presence of contaminants. The frequency and intensity of X-rays returned from the IC surface identify the contaminant material, chlorine in the lower photo, carbon in the other.

associated with the high-temperature process in manufacturing IC's.

Shorter wavelengths show more

Very small defects, such as pinholes in an oxide layer, require instruments with better than 0.5-micron resolution. This is the maximum resolution of optical microscopes, because it is the wavelength of visible light. X-rays, with wavelengths of about 1 angstrom, and electrons with associated wavelengths of less than 0.1 angstrom [1 angstrom= 10^{-4} micron] give this improved resolution. However,

microscopes that can focus X-rays cannot at present magnify more than about 200 times.

The transmission electron microscope can help find the causes of unstable electrical properties in IC's by measuring the size and shape of selected sections of the IC's, or can locate stacking faults, a type of defect associated with epitaxial deposition. The transmission electron microscope offers the best resolution of any method of electron microscopy. But it requires an extremely thin sample and this normally destroys the function of the device being tested. Thinning of the sample for direct

examination requires removal of contacts and destroys most of the device. One way to circumvent this is to form a thin cast of the sample surface, but that contaminates the surface.

Electron-opaque specimens can be examined with the scanning electron microscope. As its name implies, a thin beam of electrons scans the specimen surface and detects either the electrons scattered from the surface or those absorbed by the specimen. The scanning electron microscope is useful for studying the topography of an IC and determining the cause of such failure modes as open circuits,

Weapons against IC failure

Instrument and procedure	What's measured	Sensitivity,* resolution or power
(Physical properties)		
Optical microscope Phase contrast	Size and shape Stacking faults	3X to 2,000X, 0.5 micron To 1,000X, 0.5 micron
Electron microscope	Size and shape Dislocation and stacking faults	Less than 10 angstroms or better 100 angstroms apart
Interferometer Single beam Multiple beam	Film thickness or surface roughness	300 angstroms 25 to 10 angstroms
Profilometer	Film thickness or surface roughness	25 to 100 angstroms
Contour analyzer	Surface contour along a line shadow	1 micron
Ellipsometer	Film thickness, dielectric Film thickness, silicon	2 angstroms 10 microns or less
Electron diffraction microscope Reflection Transmission	Crystal identification (contaminants)	Needs 1 mm sample Less than 1,000 angstroms sample size
Low energy electron diffraction (<400 v)	Surface structure (generally indicates presence of absorbed materials)	1 to 2 atomic layers deep
Scanning electron microscope	Device topography	0.05 to 0.5 micron
Radiography unit	Inner topography	0.1 micron
X-ray diffraction	Phase analysis Crystallite size Dislocation mapping	0.5% to 10% 0.05 to 0.3 and 10 to 1,000 micron ranges Over 5 microns apart 5,000 psi or 500 ppm strain over area 0.010 in. across
Strain gauges	Strain, thus stress	1 ppm over 0.015 in.
Tensile testers	Bond strength	0.1 gram
Thermal plotter	Surface temperature	2°C over 0.00035 in. diameter
Etching	Dislocations or stacking faults	10 microns apart
(Electrical properties)		
Oscilloscopes	Current and voltage	1 nanoampere
Ammeters and electrometers	Current	10 ⁻¹⁵ amperes
Voltmeters	Voltage	10 ⁻⁹ volts
Capacitance bridges	Capacitance	10 ⁻¹⁷ farads, static
Ohmmeters	Resistance	10 ⁻⁵ ohms

shorts or electrical leakage.

Since an electron beam may permanently alter the electrical characteristics of a device, the electron microscope is considered destructive. In the electron mirror microscope, however, electrons do not touch the specimen, but are reflected back for viewing by an equipotential barrier near the sample. The electrons do get close enough to acquire the information necessary to give a picture of the electromagnetic condition of the integrated circuit's surface—with a reported resolution of 0.2 micron.

After locating a flaw on the surface of an ic, it is often necessary to measure the fault to determine its severity. A large array of instruments is available to do this, each with its own particular liabilities and assets. Profilometers and interferometers can measure the topography of a surface. Interferometers, ellipsometers and betascopes can directly measure film thickness. And X-ray diffraction and spectroscopy can measure film thickness by analyzing the weight per unit area of the chemical elements of the film.

A profilometer utilizes a small, lightly loaded

Instrument and procedure	What's measured	Sensitivity,* resolution or power
(Chemical properties)		
Absorption spectroscopy Atomic	Detection of chemical elements	2 ppb of Mg or Zn in water <1 ppm of Al, Fe, Co, or Ni
Infrared, attenuated total reflection	Surface composition	Depth is about 1 wavelength, depending on the angle of reflection
X-ray	Chemical composition, oxidation state	10 to 1,000 ppm
Emission spectroscopy Visible X-ray Neutron activation	Chemical composition	1 ppm of most elements 10 ppm of most elements 1 ppb of most elements, 1 ppm of oxygen
Mass spectroscopy Gas Spark	Chemical composition	0.02 to 200 ppm 10^{-13} torr 1 ppb of many elements, 20 to 200 ppb of H, N, C, O
Sputter		1 to 10 ppm in surface which is removed at 10 to 100 monolayers per second. Area 0.1 mm across may be analyzed.
Gas chromatography	Chemical composition	1 ppb hydrocarbons 1 ppm H, 10 ppm Ar, 500 ppm water
Electron spin resonance	Chemical composition	10^{11} unpaired electron spins/cc. Equivalent to 10^{12} atoms/cc of P in Si, and 10^{14} atoms/cc of Sb in Si, and 10^{-6} mols/liter.
Nuclear magnetic resonance	Chemical composition	2,000 ppm, analysis suitable for structural,
Charged particle spectroscopy	Surface contaminant identification	Atomic number difference of 1
Electron microprobe X-ray mode	Detection of chemical elements	Less than 1 monolayer 10 ppm in bulk (1,000 ppm for lightest elements)
Specimen current mode	Device topography	0.5 to 1 micron
Wet chemistry Colorimetric Fluorimetric Ion exchange	Chemical composition	10 picograms 1 picogram of most elements Concentrates ions 100X
Carbon analyzer	Carbon determination	10 ppm
Vacuum fusion	Chemical composition	50 ppb H, 200 ppb of O or N

* Sensitivities quoted are the highest given in apparatus makers' literature.

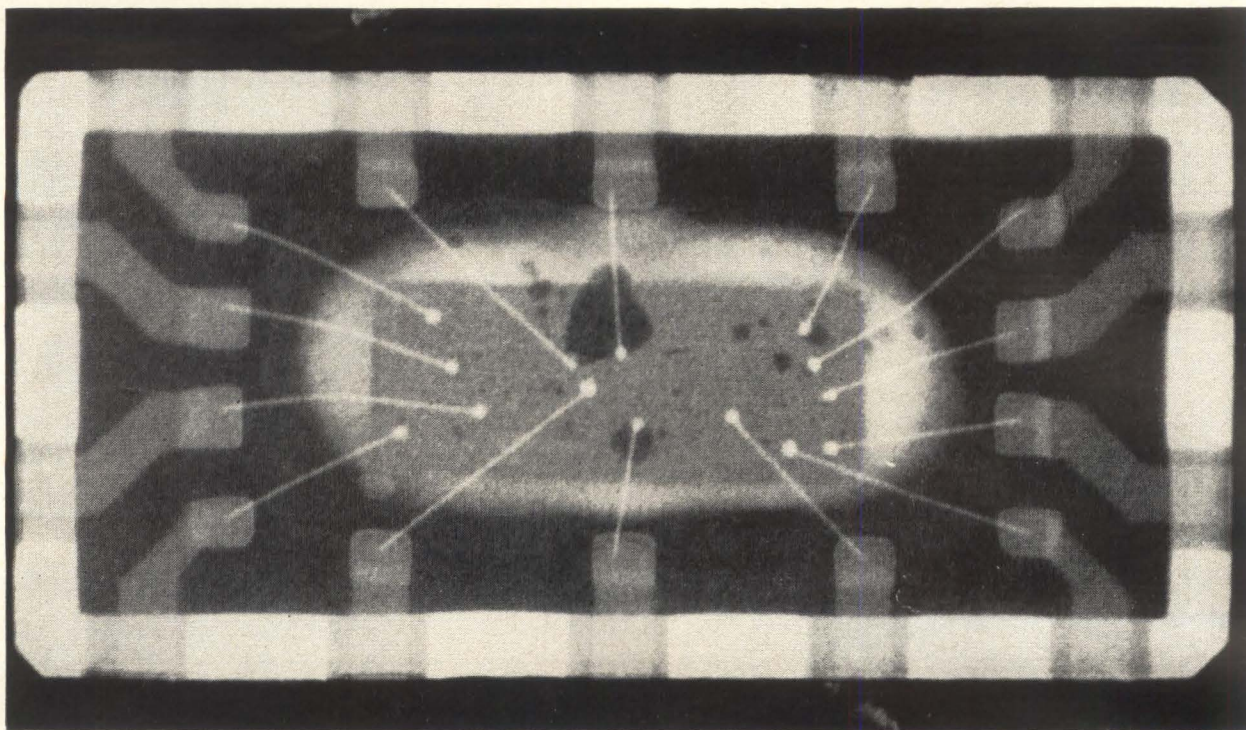

Radiographic techniques expose bad bonding of the IC die to the package that can cause the device to overheat and fail. The dark spots in the radiograph are voids in the braze under the silicon die. The radiograph shows details as small as the 1-mil interconnecting wires.

hemispherical probe that slides over the surface being measured. Its movement normal to the surface is sensed and recorded or displayed. The instrument can measure surface smoothness or step heights from 25 to 100 angstroms. However, the profilometer is often unable to distinguish a crack from a shallow scratch.

Measuring steps

An interferometer, however, can measure any small irregularity in a sample surface plus steps at the edges of masked deposited films and thus give information about flatness and smoothness, including scratch and hole depth. Steps on an IC surface, even though not a defect in themselves, can trap contaminants and result in a variety of failure modes—corrosion or open bonds, for example. The interferometer measures differences in the optical path length of the two parts of a light beam separated by a partially reflecting mirror.

If only one part of the beam traverses the sample film, the difference of the optical path between the two parts is a measurement of film thickness. If the upper surface of a transparent film is partially reflective, the parts of the incident light being reflected from the upper and lower surfaces may interfere with each other and, for incident white light, the resultant color is a measure of the film thickness. Singly reflecting arrangements give a precision of 1/10 to 1/20 of the wavelength of light—about 200 angstroms. Accuracy is partly dependent on applying the proper corrections for both the index of refraction and the phase shift

caused by the reflection. Films more than 1-wavelength thick may be measured and their refractive indexes determined by a method that measures phase difference as a function of angle of incidence.⁵

To measure step heights on a reflective surface, a partially reflective plate is placed over the sample; corrections for the index of refraction and varied phase shift caused by reflection from different materials are not needed. If the additional plate is 90% to 95% reflective, the diffraction fringes are sharpened and measurements are accurate to 10 angstroms. Fairly economical instruments are available which have a precision of 25 to 30 angstroms.⁶

Transparent films thinner than 1 wavelength may be measured by ellipsometry to a precision of 3% down to a thickness of 2 angstroms. The ellipsometer makes use of polarized light. Polarized light reflected at various angles from very thin films changes the polarization. This change is dependent on and a measure of both the thickness and refractive index of the film. However, because the measured numbers are not linear variables of film thickness, corrections must be assessed and applied to compensate for any contaminating film.

Atomic probes

When there is no surface evidence of the thickness of opaque films, the thickness may be measured nondestructively by penetrating radiation. Also the backscattering of beta radiation by film and substrate can be measured since the

scattering power of material increases strongly with atomic number.

If there is an appreciable difference in atomic number between the film and substrate and the compositions of both film and substrate are known or standards are available, the scattered intensity can be related to the film thickness. This results in a measure of thickness for films from 1 microinch to several mils with an accuracy to within a few percent.

Inside the chip

Inversion (change in semiconductor type) and many other failure mechanisms are the result of absorbed contaminants in the IC wafer or structural defects. Therefore other tests must be made to examine the wafer's physical and chemical properties.

To examine the interior of a specimen, more penetrating radiation is required and X-rays are normally used. A shadow-casting process is capable of detecting effective thickness variations of about 0.5%. And the resolution of the method, a function of the geometry of the setup, can be 0.1 micron although a resolution as coarse as several microns is still useful. Precise resolution requires either special equipment or techniques. Fine-resolution X-ray plates (capable of being enlarged 400 times with a conventional microscope) can clearly show the placement of 1-mil wires, cracks, voids and contaminants.

A stereoscopic view of the interior of a sample—made from two radiographs taken at different angles—can make crystalline defects more apparent. A variation of sectional radiography,⁷ lamina-graphy, passes X-rays through the sample and the film at about 20° to the plane of the film. At the same time, the sample and film are rotated synchronously about their respective normals, which are parallel. The only portion of the sample that forms sharp shadows on the film is the plane that intersects its own rotation axis exactly on a line between the X-ray source and the intersection of the film with its own rotation axis.

One technique, three uses

X-ray diffraction can aid failure investigations in three ways: first, examination of X-ray diffraction patterns identifies phases and confirms the identity of construction materials and contaminants. The pattern also contains information about the quality of the crystals in a material and the size, shape and distribution of the particles or crystallites. It can reveal whether a noncrystalline material is dense and glassy or is an open structure with spaces between the atoms. Second, X-ray diffraction (and electron microscopy) can show the nature and distribution of grain boundaries and crystallographic defects, such as dislocations and stacking faults. Third, it can demonstrate and measure stress in any crystalline material.

In the examination of integrated circuits, a common task is to identify contaminants that

cause short circuits or otherwise change the device performance. X-ray powder diffraction is a fingerprinting method—a pattern of the crystalline contaminant is compared with the patterns of known substances to identify the contaminant.

Crystallographic defects can also affect electrical and mechanical properties of materials. The defects may be misplaced atoms, grain boundaries or gross strain—resulting from a fracture or from constraint by adjacent incompatible material.

A dislocation is one form of a collection of misplaced atoms and contains a linear array with an environment different from that in a perfect crystal. Associated with the dislocation are variations of interatomic distances and strained interatomic bonds. In the immediate vicinity of the dislocation, the differences in interplanar spacings result in a difference of diffracted intensity recorded on the X-ray diffraction topograph or electron micrograph. Stacking faults, another form of misplaced atoms, do not cause appreciable strain or change in interatomic spacing but they still modify the crystal diffraction grating and show contrast on a diffraction topograph.

An optical alternative is phase-contrast microscopy. Because stacking faults formed in epitaxial silicon layers cause a slight departure from surface flatness they are often detectable by phase contrast microscopes. Also since the strain associated with dislocations and stacking faults affects chemical reactivity, the defects can be located by etching procedures.

Examining IC's chemically

Chemical analysis is also employed in investigating failures to analyze the material and to identify contaminants. However, it requires skilled technicians and this often precludes its use by the

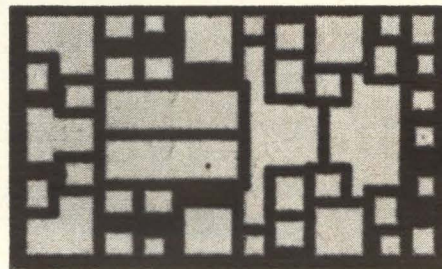
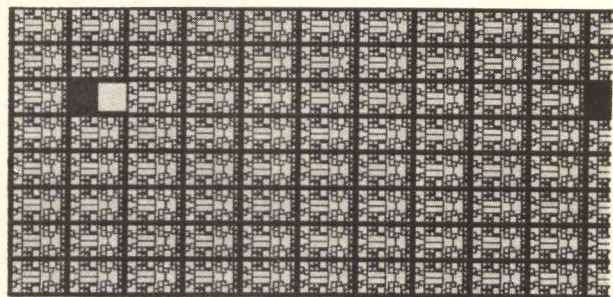

Pinholes in the insulating material of an IC are hard to spot and can create shorts. They can be located, however, through microscopic examination of a benzidine recording of the wafer. The benzidine emphasizes pinholes.

Failure analysis: a two-edged sword



Failure analysis may appear at first glance to be the responsibility of the manufacturer of integrated circuits. But says author Seymour Schwartz, ic's are so complicated and the manufacturer is so dependent on the user's specifications that the user has to share the responsibility.

Schwartz, of the National Aeronautics and Space Administration's Electronic Research Center, says the customer has a real stake in preventing ic failures. He notes that the customer may have even designed the circuit. As chief of the failure mech-

anisms branch of NASA's Qualification and Standards Lab at Cambridge, Mass., Schwartz devotes most of his work to integrated circuits.

He says that failure analysis can pinpoint whether design weakness or poor processing is responsible for trouble in the ic's. And, he says, the result can be increased manufacturing yield and greater quality control, assuring customers that failures will not be repeated.

Schwartz has more than 15 years experience in the semiconductor field. He is editor of "Integrated Circuit Technology: Instrumentation and Techniques for Measurement, Process and Failure Analysis," to be published this year by the McGraw-Hill Book Co.

small-volume ic user. Chemical ic tests include the examination of the finished devices and the materials in the manufacture plus analysis of ambient gas sealed into the device package.

Wet chemical methods can analyze the major chemical elements in the device and are the basic references to which other chemical methods are compared; typically their best accuracy is one part per thousand.

Identifying the major elements

Among the instruments available to assay major elements present are the optical emission spectrograph, the X-ray fluorescence emission spectrograph, the electron probe microanalyzer and the mass spectrograph.

Oxidation or polymerization states in a sample of material may be determined by soft X-ray emission spectroscopy, high resolution X-ray absorption spectroscopy, nuclear magnetic resonance, nuclear quadrupole resonance, electron spin resonance and Mossbauer effect spectroscopy.

To detect trace elements, neutron activation analysis, mass spectrography and atomic absorption spectrography are especially versatile and sensitive.

In addition, volatile materials absorbed on a surface may be desorbed by heating in a vacuum or removed by chemical displacement and analyzed by gas chromatography or mass spectroscopy. The presence of very thin layers of contaminants or residues may be detected by physical methods such as the stick-slip method,^{8,9} wettability tests, contact resistance measurement and low-energy electron diffraction, which examines a surface layer to a depth of only one or two atomic layers. In the stick-slip method, a clean probe is dragged across the surface of the material. The friction-mechanical drag is monitored and abnormal readings indicate the presence of residues. Electron diffraction at normal voltages can demonstrate the presence of thicker films and identify crystalline films in much the same way an X-ray diffraction identifies crystalline phase.¹⁰

Mechanical stress measurements are made on devices during thermal stressing, or during manufacture, to determine the allowable magnitude of operating and processing stresses. Leads, welds and bonds are tested for strength to insure that the manufacturer's joining processes are under control. Since annealed, 1-mil gold wire has a breaking strength of only about 5 grams, the testing machine must have a sensitivity of a fraction of a gram. The machine is designed to apply stress in shear or tension to a lead or to twist it. Leads are also bent back and forth under load to assess the component's ability to withstand the strains of assembly and careless handling.

References

1. Workman, "Failure Analysis Techniques" in "Physics of Failure in Electronics," RADC Series in Reliability, vol. 3, 1965, pp. 238-263.
2. J.E. Meinhard and P.J. Besser, "Investigation of Methods for the Detection of Structural Defects in Silicon Oxide Layers," Symposium on Manufacturing In-Process Control and Measuring Techniques for Semiconductors, Phoenix, Ariz., March 9-11, 1966.
3. S.W. Ing, et al, "Gas Permeation Study and Imperfection Detection of Thermally Grown and Deposited Thin Silicon Dioxide Films," Journal of the Electrochemical Society, Vol. 109, 1962, pp. 1,206-1,212.
4. R.M. Finne and D.L. Klein, "A Water-Amine-Complexing Agent System for Etching Silicon," Journal of the Electrochemical Society, Vol. 111, 1964, p. 63C.
5. W.A. Pliskin and E.E. Conrad, "Nondestructive Determination of Thickness and Refractive Index of Transparent Films," IBM Journal of Research and Development, Vol. 8, 1964, pp. 43-51.
6. E.J. Scherago, "Guide to Scientific Instruments," Science, Vol. 150A, No. 3699A, 1965, p. 69.
7. A. Taylor, "X-Ray Metallography," John Wiley and Sons Inc., 1961, p. 56.
8. S.M. and J.W. Dzimianski, "Nonlinear Mechanisms and Stress Concentrations" in "Physics of Failure in Electronics," RADC Series in Reliability, Vol. 1, 1963, pp. 35-55.
9. J.W. Dzimianski, "Silicon Surface Passivation: Materials and Micro Properties" in "Physics of Failure in Electronics," RADC Series in Reliability, Vol. 2, 1964.
10. C.S. Barrett, "Structure of Metals," McGraw-Hill Inc., 1952, pp. 581-600.

Acknowledgment

Part of this article is based on material supplied by George V. Browning, Joseph M. Axelrod and Philip H. Eisenberg of the Material and Processing Lab, Autonetics division of North American Aviation Inc.

"If you're buying our new integrated circuit op amp JUST for the 60,000 gain you may be missing several advantages!"

Certainly, our new MC1533 provides open-loop gain that's 15,000 higher than the next best. (Typically, 60,000 — with 40,000 guaranteed minimum). But, it also features extremely low temperature drift (for better stability) combined with low input offset voltage and gain adjustability, too. Best of all, it's competitively priced . . . and, available **RIGHT NOW!**

This extremely flexible operational amplifier sets new performance standards for a variety of applications. The high gain and temperature stability are extremely valuable for use in sensitive applications such as an integrator. Design simplicity and lower costs (because there's seldom a need to cascade) result from the added gain and low input offset voltage in other applications such as summing amplifiers, source followers, twin tee filters and oscillators.

For an even wider range of applications, you can now get two different series of these state-of-the-art devices, in 10-pin TO-5 or flat-

pack, priced as low as \$15.00 (100-up). Here are some of the documented specifications that make it all possible:

CHARACTERISTICS	MC1533G	MC1433G
Price (100-up)	\$34.00	\$15.00
Power Dissipation	120 mW	120 mW
Operating Temp. Range	-55 to +125°C	0 to 75°C
Open Loop Voltage Gain — A_{VOL} (min.)	40,000	30,000
Voltage Drift With Temp. (Typ.)	$8\mu\text{V}/^\circ\text{C}$ ($T_A = -55$ To $+25^\circ\text{C}$) $5\mu\text{V}/^\circ\text{C}$ ($T_A = +25$ To $+125^\circ\text{C}$)	$10\mu\text{V}/^\circ\text{C}$ ($T_A = 0$ To $+25^\circ\text{C}$) $8\mu\text{V}/^\circ\text{C}$ ($T_A = +25$ To $+75^\circ\text{C}$)
Input Impedance (typ)	1 Megohm	600 Kohms
Output Voltage Swing*	± 12 volts	± 12 volts

* $\pm 15\text{V}$ Supply with R_L 2 Kohms

For complete details on the World's Best Op Amp Integrated Circuit, send for our data sheets and the Application Notes described at right. For immediate delivery on devices you'll want to try, contact your nearby Motorola franchised semiconductor distributor.

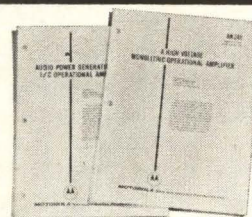

HOW TO USE HIGH GAIN OP AMP DESCRIBED IN TWO NOTES

Designing source followers, twin tee filters and oscillators, and high impedance voltmeters are presented as examples of the wide variety of applications for the MC1533 operational amplifier. In addition, three complementary audio frequency amplifiers are discussed, each using an MC 1533 to obtain the desired voltage gain and reduce the distortion figure. Motorola Application Notes 248 and 275 are sure to be valuable additions to your library of integrated circuit information. Send for them today!

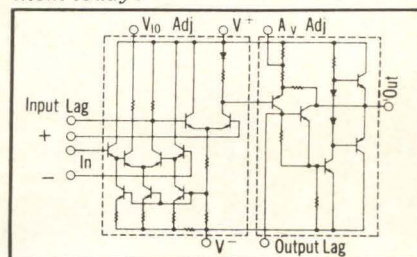

The MC1533 is considered a multi-stage amplifier, and is constructed to best use the advantage of monolithic integrated circuits. The dotted lines separate the stages.

where the priceless ingredient is care!



MOTOROLA Semiconductors

MOTOROLA SEMICONDUCTOR PRODUCTS INC./P. O. BOX 955/PHOENIX, ARIZONA 85001/(602) 273-6900/TWX 910-951-1334

Chronometer expands pulses to measure nanosecond intervals

'Stretching' time intervals solves pulse-measurement problems in systems such as optical radars and nuclear detectors

By George M. Ettinger*

G. & E. Bradley Ltd, London

An inexpensive, accurate instrument resolves time intervals down to 10 nanoseconds and makes it possible to display the time interval data on a low-speed oscilloscope. Alternatively, the pulse length or time interval data can be stored in an electronic integrator and read out on a meter or chart recorder. The device promises to solve a variety of problems in which very short accurate time intervals must be measured.

An example is timing the pulses of laser ranging systems. Optical radar systems should approach the ultimate in range resolution capability. Because they use high-power lasers emitting light pulses as short as a few nanoseconds, they should be able to resolve distance measurements to within a few feet. But optical radar designers have consistently run afoul of two major problems. First, circuits required to resolve accurately the nanosecond interval between the transmitted and received pulses are complex and costly. Even more important, high-power lasers are limited to low repetition rates because of their relatively long recovery time. As a result, conventional cathode-ray tube readout is ruled out because single-shot, high-speed operation of crt's produces a display of intolerably low brilliance.

*Now engineering manager, Rotax Ltd., London

The author



George M. Ettinger obtained his Ph.D. from London University in 1960. He is the author of a book and numerous papers on magnetics, power control systems, high-speed pulse devices and measurements. At G. & E. Bradley, he was responsible for the design and development of several measuring instruments and precision calibration equipment.

Attempts to solve these problems with photographic techniques have been unsatisfactory because of the time lag imposed by film processing. Another approach makes use of high-speed counters with resolutions of 10 to 50 nanoseconds. However, such counters are complex and expensive.

The new instrument, called a nanosecond chronometer, relies on the simple principle of 'time' expansion. Instead of displaying the short pulses directly, they are converted to proportionally longer pulses—'time' is expanded—and range information is derived from the longer pulses.

The expansion technique eliminates the need for costly counters. Short pulse intervals are lengthened in an interval expansion circuit built with tunnel diodes and transistors. Pulse intervals expanded by a factor of 1,000 can be resolved to within 10 microseconds, which corresponds to 10 nanoseconds in real time. Because the pulses have been placed in the millisecond region, they can be observed with adequate intensity on low-speed oscilloscopes in spite of their low repetition rate.

For readout on a meter or recorder, the expanded pulses gate a constant-current source to the input of a very stable electronic integrator. The integrator output is proportional to the period during which the d-c input is applied. Since the expanded period is proportional to the original short time interval from the optical radar before the expansion, the integrator output voltage is also proportional to the original time interval.

The information is stored in the capacitor of an integrator which has a drift of less than 0.1% of full scale per minute. The output resistance of the integrator is sufficiently low to allow connection of a panel meter and a chart recorder without introducing additional drift. The recorder can indicate long-term trends in cloud height radar.¹

The integrator is not required for digital data

storage. For this mode of operation, the expanded pulses directly gate a fixed-frequency signal—say, 100 kilohertz—to produce an output of one pulse train per radar echo; with a 100-khz signal, the number of 10- μ sec pulses in each train is proportional to the original time interval.

Pulses control operation

The basic elements of the nanosecond chronometer are: a start, stop and interval expansion circuit, a pulse former, an electronic switch, an integrator and a readout device as shown below. Start and stop pulses are amplified to a level of 1 volt and applied to a gate. The gate switches a tunnel diode on and off to control a high-speed transistor.

When the transistor is in the waiting state, it is turned full on, so that the anode of the tunnel diode is nearly at ground potential. The transistor is turned off when a positive pulse of length t_x is used for the transistor collector and the value of capacitor C_1 is chosen so the collector reaches only 7 volts at the maximum time interval t_x . The 15-milliampere current, normally flowing through the transistor's collector-emitter circuit, is then diverted from the transistor, through the diode D_2 and charges capacitor C_1 . At the end of the pulse, the transistor rapidly returns to its saturated or full-on state. Diode D_2 is now reverse-biased and prevents the capacitor from discharging through the transistor. Instead, it discharges through R_2 at a relatively slow rate, determined by the ratio of the charge and discharge currents. For example, if the charge current of 15 ma is 1,000 times the discharge current—then the discharge time will equal 1,000 t_x .

The pulse former connected to C_1 is a bistable circuit that acts as a low-leakage electronic switch, closing each time the positive voltage on the capacitor C_1 exceeds a preset value or threshold.

The electronic switch permits a constant charging current to flow into the integrator capacitor during the time interval 1,000 t_x . The capacitor charges linearly, eventually reaching a voltage proportional to t_x . To store this voltage without any appreciable drift between measurements, both capacitor C_2 and

the integrator input must exhibit very low leakage. Putting a forward-biased field effect transistor whose gate current is less than 100 picoamperes in the input stage accomplishes this.

Nonlinear characteristics

A fixed interval-expansion ratio can be obtained only if the system is linear. Linearity is controlled primarily by the degree of stability of the charge and discharge currents.

Linearity can be optimized if R_1 and R_2 , which determine the currents, are replaced by such true constant-current sources as bipolar or unipolar emitter followers or source followers. However, good linearity—within 1%—can be obtained with the passive resistors by operating the circuit over a restricted portion of the chronometer's exponential characteristic curve. To do this, a 35-volt d-c supply is used for the transistor collector and the value of capacitor C_1 is chosen so the collector reaches only 7 volts at the maximum time interval t_x .

A relatively high discharge supply voltage—120 volts—keeps the discharge current constant whether capacitor C_1 charges from zero to 1 or zero to 7 volts during the interval. The nonlinearity contributed by the discharge characteristics under these conditions is again about 2%. Absolute scaling errors, created by the tolerances of the charge and discharge resistors and capacitor C_1 are eliminated by preset controls in the discharge circuit.

For some applications, nonlinear characteristics are desirable. An exponential characteristic permits the display of a wide range of times, and therefore target distances, on a single meter range. Such a characteristic is achieved by allowing capacitor C_1 to charge up to nearly the full positive supply voltage while keeping the discharge current essentially constant.

Eliminating ambiguity

In optical radars for measuring distances, separate start and stop pulses are employed. An ambiguity may arise when echoes are received that

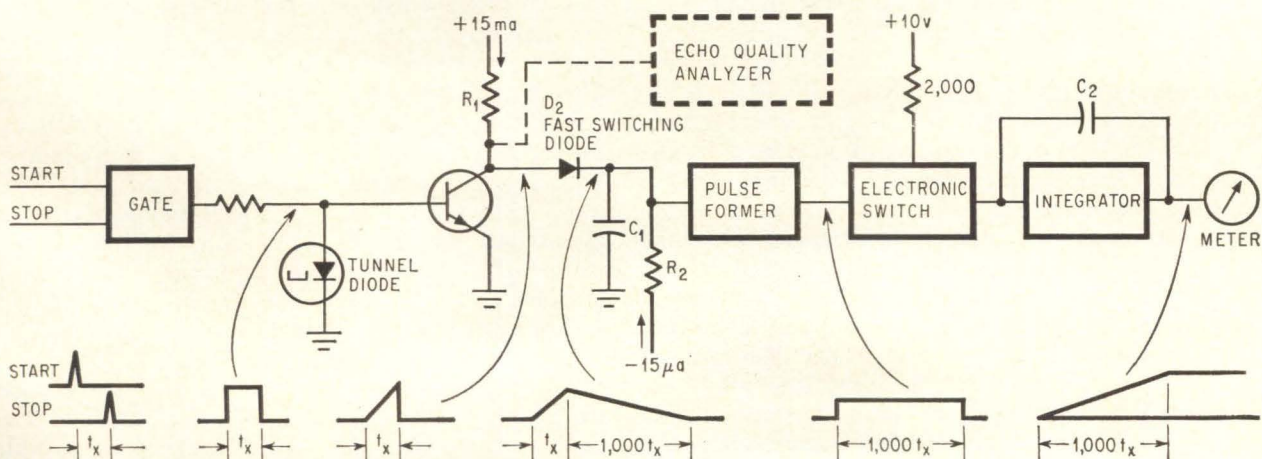

Nanosecond chronometer. Tunnel diode-transistor circuit lengthens time interval between start and stop pulses applied to gate. Switching diode prevents capacitor's charge from returning to ground through the transistor once it is turned full on by the tunnel diode after echo is received.

Chronometer output characteristics

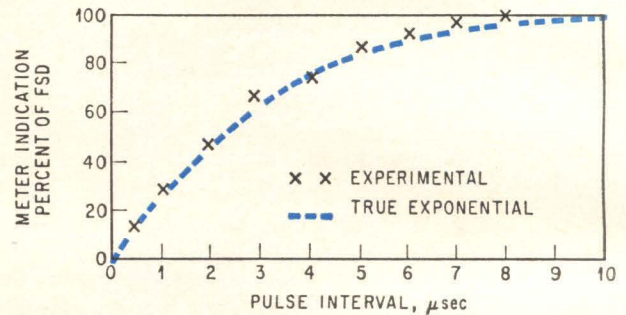
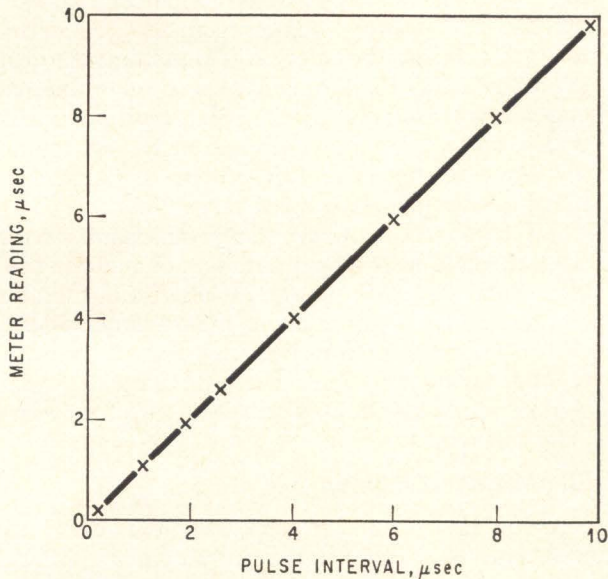
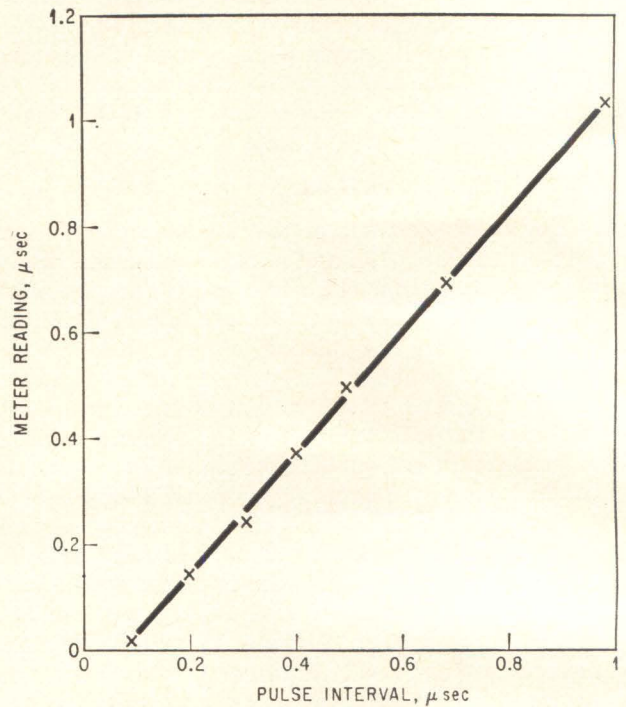
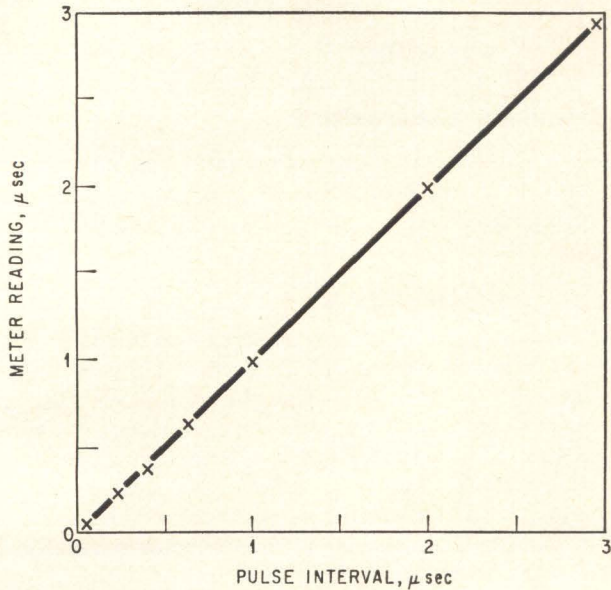

Time-voltage transfer curves for several ranges of the chronometer. Restricting the chronometer's operation to a portion of its complete range keeps the readout linear. The readout can also be made exponential if desired. The curve directly above shows an exponential characteristic compared with a true exponential curve.

might be returns from targets below the time and distance threshold (100 nsec in the special instrument to be described) or extremely weak or long-range echoes.

The ambiguity between a very short-range echo (below 50 feet in this case) and an extremely distant echo (greater than 4,000 or 5,000 feet, depending on the range selected) is a serious limitation. It is overcome by sensing the state of the tunnel diode and the fast transistor switch, shown on page 109, after each laser firing pulse. Then one of two neon indicating lamps is energized to indicate whether or not reset has taken place. The observer can thus resolve whether the echo has an amplitude greater than the threshold amplitude and its distance exceeds the range threshold of the system.

Making rectangular pulses

Rectangular pulses are produced in the input gate

shown at right from the start and stop signals and are fed into the tunnel diode-transistor switch used for time expansion. The tunnel diode acts as a bistable memory element, ensuring fast operation of switch Q_3 . Current is fed to the tunnel diode from transistor Q_1 which is normally not conducting. When a positive pulse is applied to Q_1 , the tunnel diode current is reduced below its valley point and the diode switches to its low voltage state. The switch is turned off and the current charges C_1 .

The stop pulse is applied to the base of Q_2 . This causes the collector of Q_2 to rise from saturation, increasing the tunnel diode current through R_3 and R_4 beyond its peak value of 5 milliamperes. The increase places the diode in its high voltage, stable state and causes Q_3 to conduct again.

The voltage drop exhibited by germanium tunnel diodes is not sufficient to control silicon transistors

directly.^{2,3} But if the d-c bias is applied to the diode through R_5 and R_6 and adjusted by varying R_7 and R_8 , the maximum voltage drop across the diode, together with the drop across R_6 , is sufficient to saturate Q_3 .

Pulses 1,000 times longer

The pulse-forming circuit senses whether the voltage across the charging capacitor exceeds an adjustable threshold value. Temperature-dependent variations of the emitter-base voltage in the transistor stage Q_4 approximately compensate for the corresponding temperature variations of the fast switching diode in the time expansion circuit.

Transistor Q_4 , normally conducting, is cut off by a positive input so that Q_5 is also off and Q_6 is turned on. Current through Q_6 closes the electronic switch Q_7 . The voltage drop across this switch is only 25 millivolts because it is operated in an inverted mode. In its normally open state Q_7 passes a leakage current of about 300 picoamperes while blocking 10 volts d-c. A drop of 25 millivolts affects the integrator sensitivity (10-volt full scale output) by only 0.25%. Since Q_7 always operates under the same conditions (switching from 10 volts to 5 milliamperes) the only change of saturation voltage to be considered is that caused by temperature. This variation is less than 1% of 25 mv per degree Centigrade—an integrator sensitivity change of only 0.0025% per degree C. This accuracy is the best that could be achieved even with special voltage reference diodes for the 10-volt supply feeding the integrator through the electronic switch. For analog presentation, a temperature coefficient of 0.02% per degree C is permissible.

The leakage in the transistor switch causes integrator drift. A leakage current of 300 picoamperes, which can be readily obtained even with pnp silicon

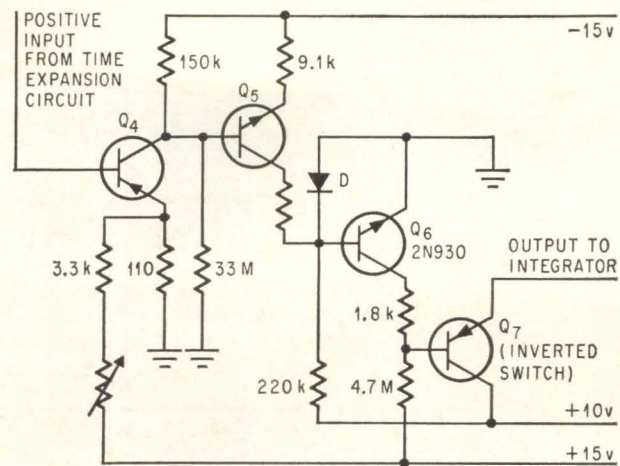

Q_4 — MULLARD LTD. TYPE BCY32 Q_7 — MULLARD LTD. TYPE OC202
 Q_5 — MULLARD LTD. TYPE BCY43 D — MULLARD LTD. TYPE OA200

Pulse-forming circuit produces a rectangular pulse from the ramp voltage while the voltage across the capacitor in the time expansion circuit returns to zero. Transistor Q_7 is inverted so that the drop across it is only 25mv.

alloy transistors, causes an output voltage drop, with a 2-microfarad integrator capacitor, of less than 10 mv per minute at room temperature, or 0.1% of the 10-volt full-scale output per minute. Variations in the leakage current have no effect on accuracy but merely reduce the storage time. For example, an allowable drift of 0.5% of full scale during the 30-second cycle time of a laser cloud height radar would permit the leakage to increase by a factor of 10 before it would have a detrimental effect on system performance.

The electronic integrator is a simple silicon transistor operational amplifier preceded by a p-channel field effect transistor operated in the zero-gate

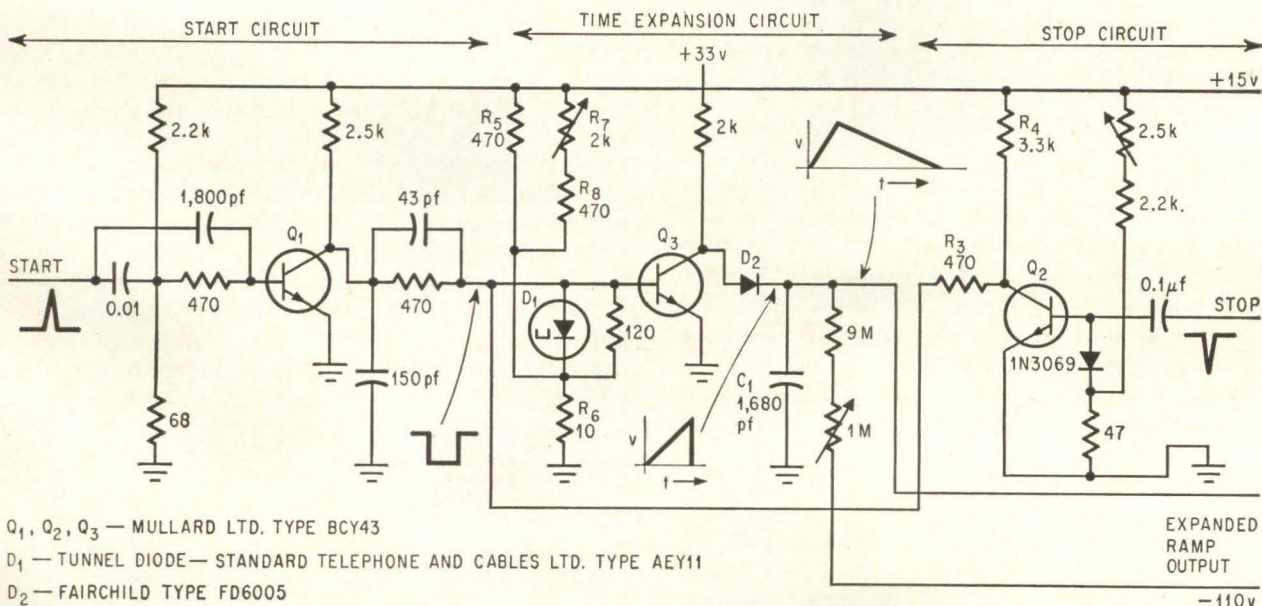

Q_1, Q_2, Q_3 — MULLARD LTD. TYPE BCY43
 D_1 — TUNNEL DIODE — STANDARD TELEPHONE AND CABLES LTD. TYPE AEY11
 D_2 — FAIRCHILD TYPE FD6005

Start, stop and time-interval expansion circuit for laser cloud height radar. Separate start and stop pulses are employed. The values of C_1 and the 9-megohm resistor are specified for the 8-microsecond range. Extra bias applied to tunnel diode cathode creates sufficient voltage drop across it to control Q_3 . The output of the circuit is a ramp waveform 1,000 times longer than the time interval between the start and stop pulses.

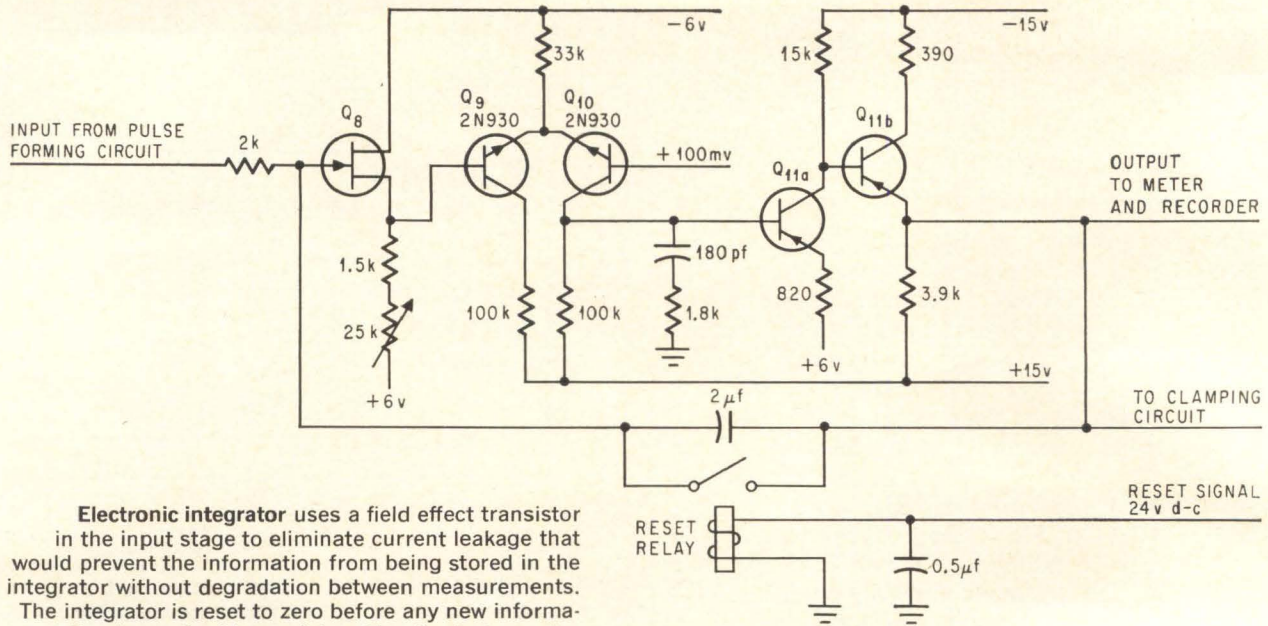

Electronic integrator uses a field effect transistor in the input stage to eliminate current leakage that would prevent the information from being stored in the integrator without degradation between measurements. The integrator is reset to zero before any new information is received by applying 24-volts d-c to a relay which creates a short across the integrator capacitor.

Q_{11a}, Q_{11b} - MULLARD LTD. TYPE OC202

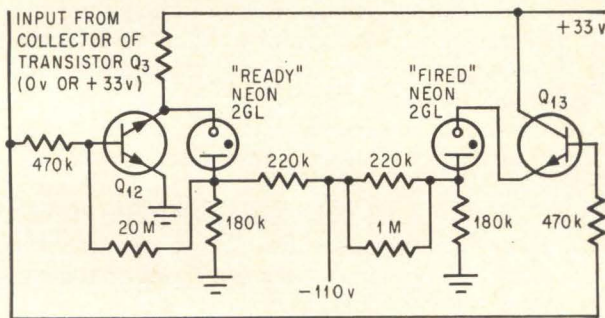

Q₁₂, Q₁₃ - MULLARD LTD. TYPE BCY43

Echo quality analyzer eliminates the ambiguity possible with certain returns. The state of the tunnel diode in the start, stop and time-expansion circuit is monitored by sensing the voltage at the collector of Q₃. The neon lamp indicating "ready" is lighted when the chronometer is in the reset state; the other lamp, indicating "fired," lights only if reset has not occurred.

current mode.⁴

The operational amplifier has a voltage gain of approximately 500 and consists of a balanced input stage, Q₉ and Q₁₀, followed by a voltage amplifier and an emitter follower. Approximately 100 mv bias on the base of Q₁₀ balances the positive bias required on the source of the FET, Q₈, to ensure zero or negligible gate leakage.

A relay shorts the integrating capacitor for about 100 msec to reset the integrator prior to the arrival of new information. A simple clamp circuit ensures that the output is reset to zero every time.

The echo quality verification circuit, shown above, determines whether tunnel-diode and transistor reset has taken place and signifies that an acceptable echo has been received. The circuit consists of two npn silicon transistors, Q₁₂ and Q₁₃, with neon indicators connected to their collector and emitter, respectively. In the reset state, the voltage

from the collector of Q₃ is nearly zero and Q₁₂ turns on the ready lamp. If reset has not taken place, the fired lamp is turned on by Q₁₃.

A one-range nanosecond chronometer has been used in a laser cloud-height radar. Only a single exponential range—100 nanoseconds to 8 microseconds—was needed, and resolution was better than 1% of full scale. A bench-type instrument was also constructed with three linear time ranges—1, 3 and 10 microseconds full scale. A time resolution of 10 nanoseconds was obtained on the 1-microsecond scale of the multirange instrument, a resolution comparing favorably with that obtained with digital counters. The time threshold is less than 100 nanoseconds. For very short range radar applications and for other high-speed interval measurements, such as the detection of nuclear particles, the effect of this threshold can be removed by delaying the echo or other stop pulse. For example, about 60 feet of coaxial cable was sufficient to reduce the time threshold to 10 nanoseconds.

The chronometer, on the 1-microsecond linear range and with echo delay, can measure from 10 to 1,000 nanoseconds with a better resolution than 10 nanoseconds and accurate within 10 to 20 nanoseconds. On higher ranges, the resolution on a meter or chart recorder is 0.5% of full scale and accuracy is within 2% of reading. The accuracy can be improved to 1% by increased stabilization of the charge and discharge currents and by compensating for the 2% nonlinearity.

References

1. "Cloud Analyzer," *Electronics*, Sept. 21, 1964, p. 34.
2. C.D. Todd, "Combining Transistors with Tunnel Diodes," *Electronics*, Aug. 19, 1960, p. 59.
3. "RCA Tunnel Diode Manual," Radio Corp. of America, Semiconductor and Materials division, Somerville, N.J., 1963.
4. G.M. Ettinger, "Some Low Leakage Properties of Silicon Junction Field Effect Transistors," *Electronics Letters*, Vol. 2, 1966, p. 149.

DOES KODAK HAVE AN ANSWER TO YOUR ENGINEERING PROBLEM?

The odds are almost 90,000 to 1 in your favor.

Let us put you in touch with the one individual among almost 90,000 Kodak people who is best qualified to deal photographically with your specific problems.

Many specialists in nonphotographic technical disciplines have a lot to gain from photography. We have specialists (photographic) who feel happiest and most useful when they can help these people solve engineering problems.

Once we know what your problems or ideas are, we can get you together with the appropriate Kodak specialist for a working session in which you may find a solution or another benefit.

We have an extraordinary diversity of products and experience. Among them there's surely some help for you. **Start with a call to (716) 325-2000, Ext. 5129. Or write Special Applications Sales, Eastman Kodak Company, Rochester, N.Y. 14650.**

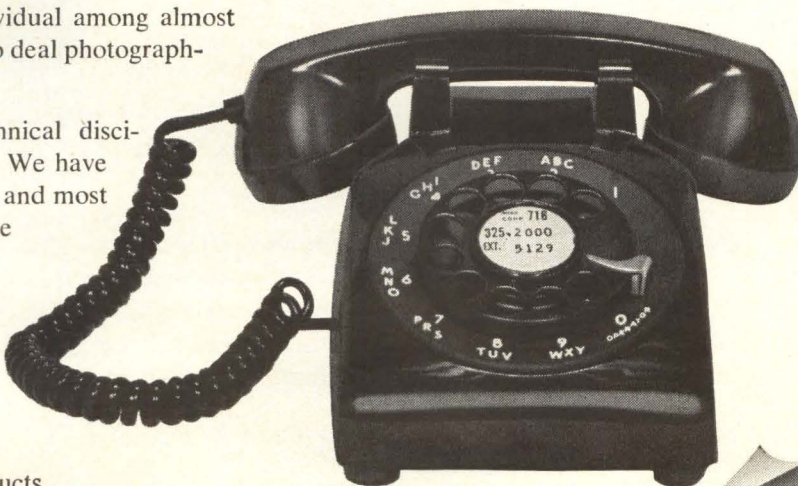

Kodak
TRADEMARK

“How can we scan temperatures at a rate of ~~10~~ 50 points/second?”

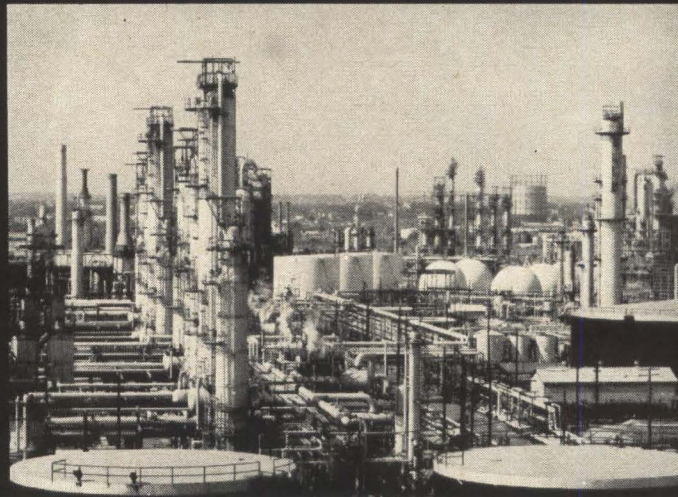

With an EMC Scanner System!

Proven EMC temperature scanner systems are now available for countless applications in a variety of industries.

Monitoring temperatures at a rate of up to 50 points a second from 0°C to 500°C with a demonstrated accuracy of 0.1% of full scale, these systems have already saved thousands of man-hours for users in the chemical industry.

These modularly-constructed systems are simple to install, operate and maintain. Pushbutton controls provide monitoring ease and flexibility. Modular units are interchangeable.



The highly reliable systems are constructed from modules with proven reliability of 4.5 million hours MTBF. This gives the typical system an MTBF in excess of 8,000 hours.

An EMC representative will be glad to provide you additional information on how EMC systems can meet your requirements for process monitoring and control.

ELECTRONIC Electronic Modules Corporation • SYSTEMS DIVISION
MODULES
CORPORATION P.O. BOX 141 TIMONIUM, MARYLAND 21093 TWX-301-0723 301-666-3300

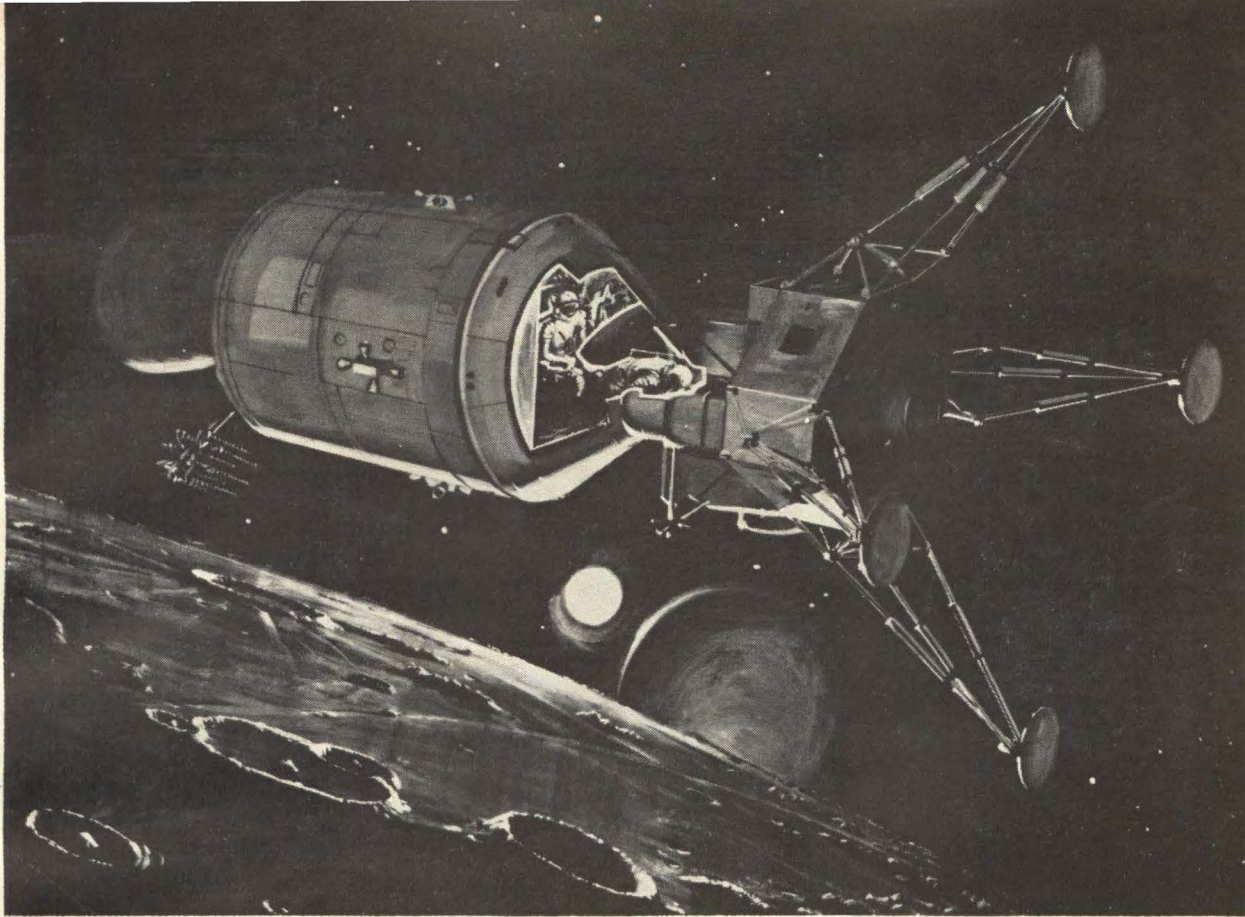

Space electronics

Apollo radar views the moon

Radar systems aboard the Lunar Module reflect the successes of the Gemini and Surveyor programs, but the moon-landing craft will be charting unexplored territory

By Richard F. Broderick

National Aeronautics and Space Administration,
Manned Spacecraft Center, Houston

The Apollo radar systems stand halfway between the relatively simple designs in the Gemini program and future systems that will allow man to explore, identify terrain and map distant planets—and to dodge asteroids or rendezvous with other spacecraft en route.

Gemini's rendezvous radar [Electronics, Jan. 24, 1966, p. 123], was a transponder-aided system, light and simple in design. It had fixed, circularly polar-

ized (Archimedian spirals) antennas and continuously measured the range and bearing of the target vehicle. The analog radar data from the receivers was digitized and fed to the Gemini computer which calculated the guidance information. Angles in two orthogonal axes were measured with three receiving antennas; the monopulse transmitter had a separate antenna.

The Apollo spacecraft's radar is more compli-

cated because the mission is more complex. The Lunar Module's radar must serve as a rendezvous aid, a landing aid and a means of calculating the orbit of the Command and Service Module while the LM is seated on the moon.

Apollo's lunar module rendezvous radar is a general-purpose tracking device that furnishes the LM with relative measurements of position and velocity. Like the Gemini radar, the LM's rendezvous system uses a transponder to measure angle, angle rate, range and range rate along the line of sight. But unlike Gemini, it uses single gimbaled, four-horned cassegrainian-configured antenna to transmit and receive circularly polarized signals.

After Apollo

Present studies indicate that the basic radar concepts developed in the Gemini and Apollo programs will be used in future space stations and Mars-flyby missions except that the smaller components in the systems will be updated.¹ Transponders will probably be located on the space stations and the Mars probe. Any earth-to-space-station

ferry vehicle will probably use components of the microelectronic phased-array radars now being developed. These devices will function as long-range altimeters and rendezvous radars. The final compositions of these systems will depend on what components are available when their designs are frozen.

As spacecraft continue to improve, they will be used to evaluate other aspects of space flight and other forms of radar applications—such as side-looking radar systems.

For guidance and navigation

Apollo, like spacecraft before it, is not an ideal radar target. The surface is rather specular at microwave frequencies so little transmitted radar energy is returned to the receiver. The radar cross section—the effective reflective area—of the Apollo Command and Service Module varies from 0.1 to 600 square meters. To track it with ground radar it is necessary to place a beacon or transponder on the spacecraft. Transponders can also be vital in aiding rendezvous, as in the Gemini program. In Gemini, the tracking radar was aboard the manned craft, while an L-band transponder was aboard the Agena that served as a target in rendezvous missions. This same technique is planned for the Apollo lunar mission.

Basically, the spacecraft's computing subsystem solves a vector relationship between R_1 , R_2 and C as in the drawing on page 118. A matrix in terms of position (R) and velocity (V) must be solved to determine the change in velocity (ΔV) that must be added to the initial velocity (V_0) of the chase vehicle to change it to the intercept velocity (V_1). The target vehicle is located in an outer circular or concentric trajectory. The chase vehicle leaves the inner concentric orbit and moves to the rendezvous point by changing its orbit from circular to elliptical.

The mechanics of this maneuver appear deceptively straightforward. Actually inertial guidance isn't accurate enough to complete the rendezvous maneuver. Radar is needed to zero in on the target. If the relative position of the two spacecraft is determined initially with an optical device such as a sextant, the inertial reference and the computer on the chase vehicle can begin the rendezvous maneuver. But the path between the chase vehicle to the target vehicle will be a broadening cone of error, within what is called a circle of ambiguity. To minimize the fuel consumed by velocity corrections (ΔV), it is necessary to narrow this cone of error with an additional sensor.

Accurate range or angle measurements, or both, can be used to calculate position while velocity can be measured with a doppler radar or computed from the position information. The Gemini radar has a pseudo-phase monopulse antenna system (interferometer) to obtain angular information and a pulse ranging system for position information. The Gemini spacecraft needed a computer to process the on-board radar data and derive



Rendezvous radar inside radome is evaluated at the Manned Space Flight Center's antenna range. Setup includes a model of Lunar Module to determine what effect the LM itself will have on the radar.

Gimbaled antenna guides the LM

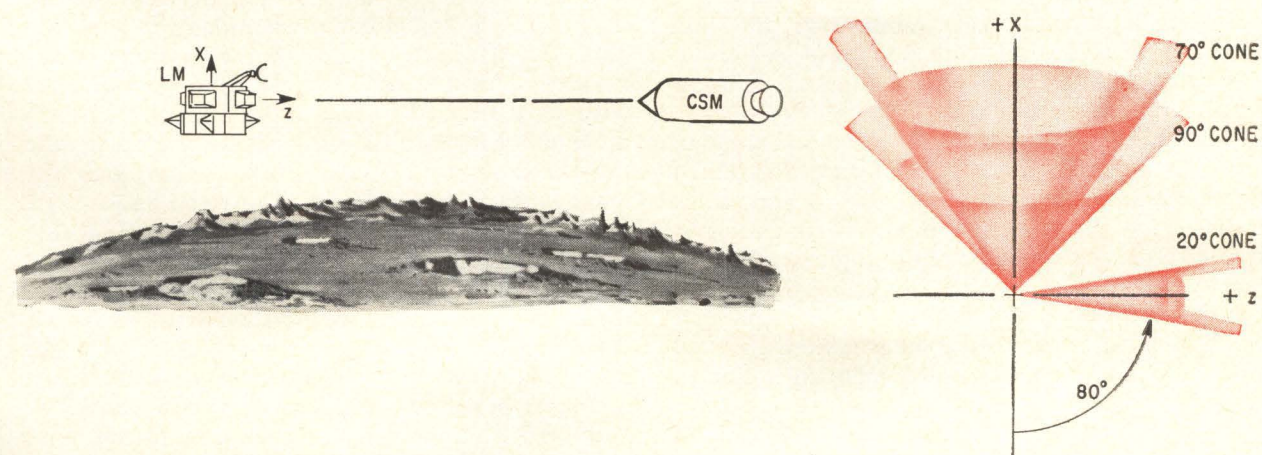
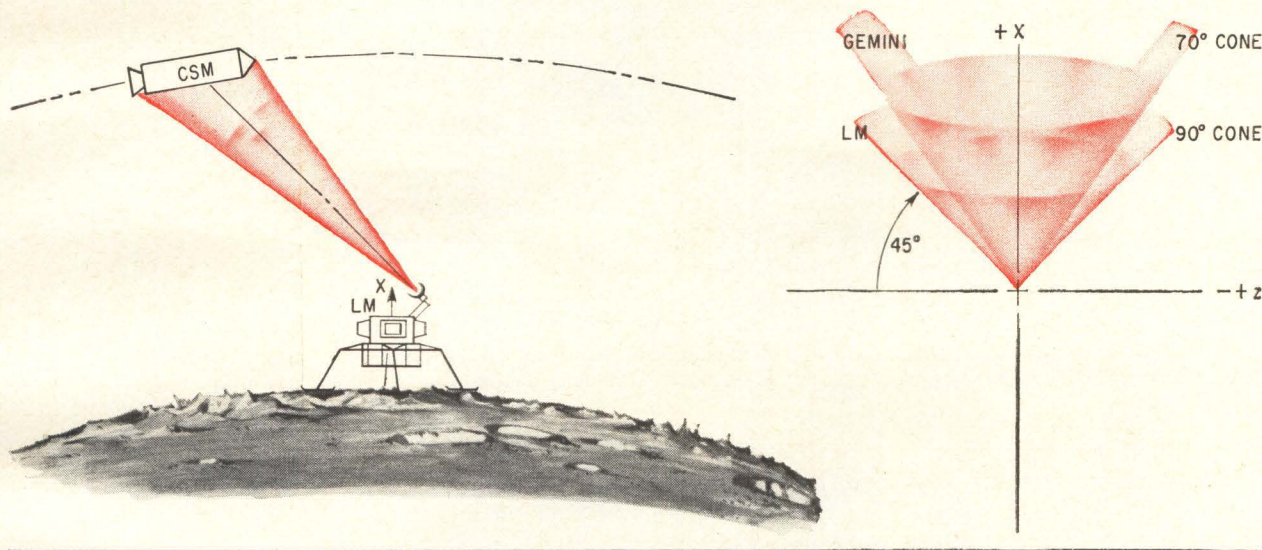
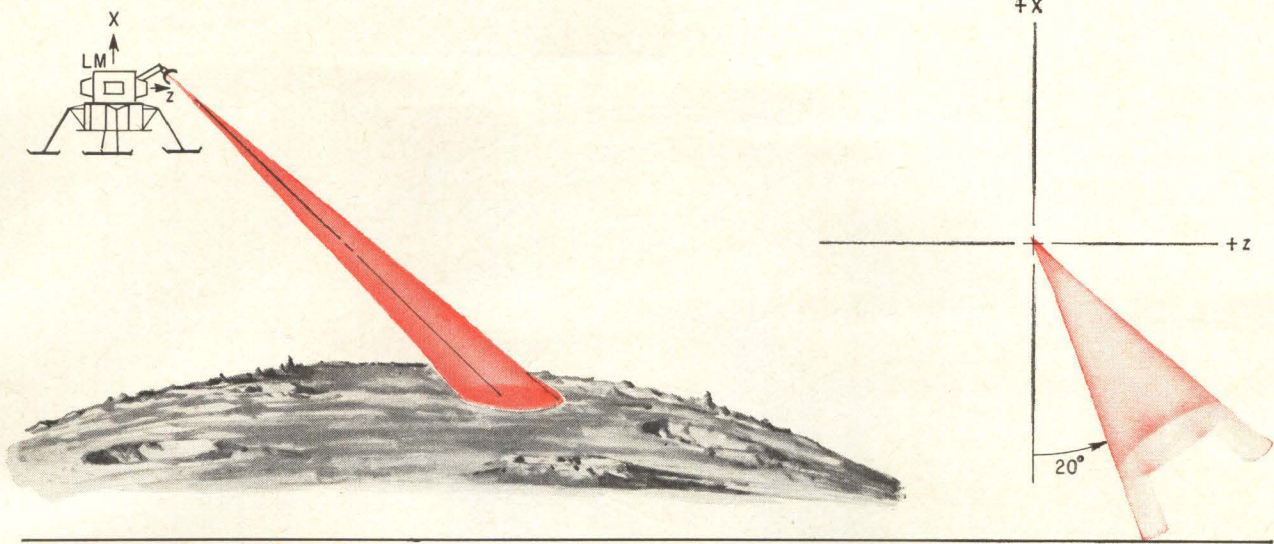

Lunar Module's antenna swings as it guides the capsule. During the landing phase shown in the upper drawing, the antenna ranges on the moon's surface. After the mission has been completed and the LM prepares to rejoin the Command and Service Module, the antenna swings upward and tracks the CSM across the sky. At rendezvous, the antenna will point along the spacecraft's "Z" axis.

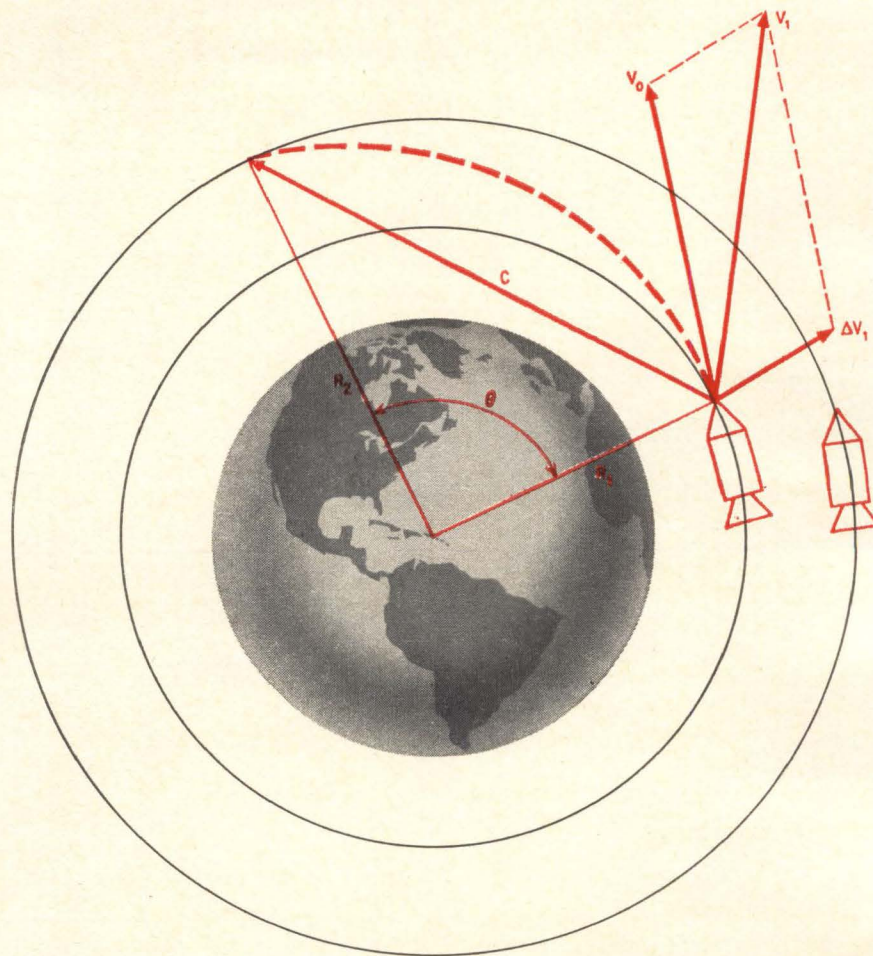

Spacecraft must transfer from a circular orbit to an elliptical path to catch its rendezvous target. The craft's computer depends on radar data to calculate the changes in velocity needed to achieve the new orbit.

in-flight velocity corrections.

The LM rendezvous radar system, however, will be able to show velocity corrections directly, without having the data fed into a computer. The LM will have an amplitude monopulse antenna system for angular information, a three-tone phase-modulated ranging system for position information and a doppler frequency tracker for velocity data.

On Apollo, line-of-sight stabilization and line-of-sight angle rate measurements are performed by four rate-integrating gyros mounted in the antenna's trunion axis.

Only two of the gyros are used at any one time and a voting logic system transfers control from one set of the gyros to the other. Upon failure of the active gyro, transfer to the redundant gyro is immediate since the voting logic continually compares their outputs.

Spacecraft electrical systems must be kept small and light and this affects the radar systems. For example, an antenna comparator technique that reduces transponder power requirements was developed for the Gemini program and will ride on Apollo. On Gemini, four receivers picked up radar signals coming from almost any direction. However, only one transmitter replied in the direction of the strongest signal. If more than one transmitter re-

sponded there would be nulls or errors in position caused by the phases of the signals in the overlapping antenna patterns. The comparator technique eliminates these nulls.

On and off the moon

When the two astronauts in the LM blast away from the orbiting Command and Service Module, they will use the rendezvous radar as a backup altimeter. After the lunar surface exploration has been completed they will update the LM computer with data from the rendezvous radar. The computer will calculate the orbit of the CSM and guide the LM during the initial liftoff period from the lunar surface. After takeoff, the radar must track along the spacecraft's thrust axis (x-axis) during rendezvous with the CSM. Because of these varied requirements, the LM must have a gimballed antenna. Gemini spacecraft used fixed antennas that were lighter and required less power; Gemini needed only one zone of coverage for rendezvous.

The selection of doppler navigation radar to guide the landing on the moon can be traced to an inherent deficiency of gyro inertial systems. Even if landmarks on the lunar surface were known and the spacecraft's inertial guidance system functioned perfectly, a position error would still exist because

the earth-based telescopes through which the lunar characteristics were determined have an inherent inaccuracy of about 1 kilometer.

In addition, doppler radar is needed to measure the spacecraft's velocity relative to the moon's surface. An inertial platform would measure the spacecraft's position relative to the center of the moon, not its surface. This would cause an altitude error of about a mile. Since an error of this magnitude is intolerable, a radar altimeter—doppler radar—with an error of less than 30 centimeters measures

the distance to the lunar surface as the LM is descending.

The altitude measurement is performed with a single frequency-modulated continuous-wave beam. The velocity components in the x-direction (V_x), y-direction (V_y) and z-direction (V_z) are measured with three continuous-wave beams.

To increase the reliability of the landing radar, the LM systems are based on conventional designs. The systems proved themselves in the successful Surveyor moon shot last year.

New radar systems will map the planets and rescue astronauts

Post-Apollo programs will concentrate on radar systems to rendezvous with space stations, explore and map planets and find lost spacecraft

After the Apollo mission, a variety of radar systems will be investigated in the Apollo Applications Program for proposed missions to Mars and Venus.

Among the types of radars to be tested is a "noncooperative" system so named because it must locate targets without the help of a system on board the target vehicle. The noncooperative system seems particularly well suited to space rescue missions and could also provide information on asteroids.

In a conventional rendezvous radar system, the radar is pointed within the inertial system's cone of ambiguity during target acquisition. After acquiring the target, the radar, with the aid of transponder provides accurate tracking data to the guidance system on the chase vehicle. To find its target, a noncooperative radar system must transmit a wide radar beam. And to receive a strong return signal it must have very high effective transmitted power because the radar cross sections of small targets vary with range and aspect angle.

The most promising form of noncooperative radar appears to be a phased array of integrated-circuit transmitter-receiver modules.

In this technique, low-power microwave modules are coupled with individual transmitting elements in an antenna array. The number of modules is determined by the antenna's aperture size and the required effective transmitted power. The arrays can be end-fire or broadside. In an end-fire, the direction of maximum radiation is along the axis of the linear array; the broadside, maximum radi-

ation is perpendicular to the plane of the array. In either case the phase of the transmitted wave would be digitally controlled with programmable shift registers. Such arrays could contain several hundred modules.

Several companies are investigating basic phased-array techniques. Texas Instruments Incorporated, in a program called MERA (molecular electronics for radar applications), is developing a

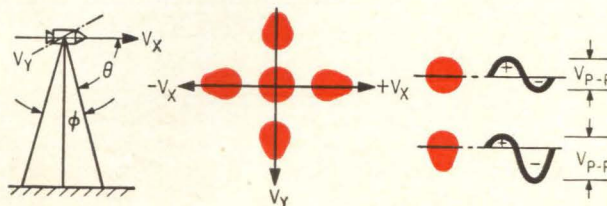

Ellipticity that results when a radar beam strikes the ground at an angle is sensed as amplitude variations. It helps spacecraft maintain a constant attitude.

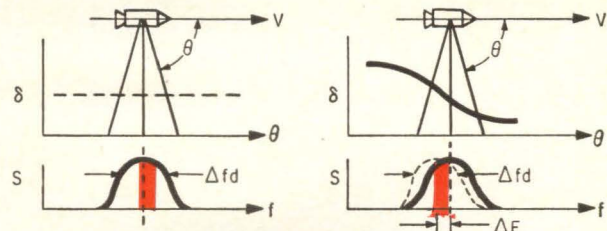

Nonuniform doppler reflections cause a radar's return signal to shift off the center frequency. Widebeam radars shift the centroid (right) and cause a terrain bias error.

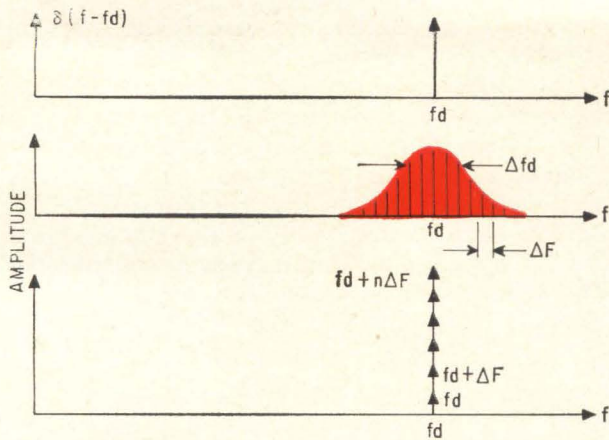

Doppler bandwidth of a pencil radar beam is very narrow (top), while a broad beam produces a Gaussian distribution of the returning doppler signals (center). Spectrum compression allows frequencies within the doppler spectrum to be superimposed to approximate the impulse function shown in the lower diagram.

terrain-following radar system for the Air Force that can also do ground mapping and determine air-to-ground range. For space, TI is developing a family of transistor amplifiers, ranging in frequency from L band (0.39 to 1.55 gigahertz) through Ka band (33 to 36 GHz.). The Radio Corp. of America is also developing microwave transmitter-receiver modules as part of an in-house program known as Blue Chip. The basic circuits operate at S band and varactor multipliers raise the output frequency to C and X bands.

Identifying the target

Besides acquiring and tracking targets, non-cooperative radar can identify a target's shape. For example, if linearly polarized vertical and horizontal waves are reflected from a sphere, the amplitude of the reflected waves will be equal. If the target is not a sphere, the returned signals

will vary in strength according to the shape of the target. Two linearly polarized waves can provide a two-dimensional picture of the target. A three-dimensional picture can be obtained by transmitting both right- and left-hand circularly polarized waves.

Such an identification system could detect asteroids, a capability especially desirable for future missions to Mars and Venus where asteroids may be a hazard. Also, identifying types of spacecraft will be necessary during the post-Apollo period when multiple rendezvous missions will be common. Quick accurate identifications will insure against false starts toward the wrong target vehicle. In addition, radar that could find and identify powerless spacecraft whose transponders are not functioning would be invaluable during rescue missions.

Inertial systems

Another radar application to be investigated in the Apollo Applications Program is a radar-inertial system capable of three-axis attitude and attitude-rate sensing. Such systems will be evaluated during earth orbits and may be used in lunar, Martian and other planetary expeditions. Since future spacecraft that use side-looking radar to map a planet's surface must maintain a constant heading in relation to their forward velocity vector, continuous attitude corrections will be mandatory. Conventional gyro inertial reference systems are set up and periodically aligned with auxiliary systems such as star trackers or horizon scanners.

A monopulse radar, however, could be used as a continuous alignment tool for the inertial system because of the radar's doppler properties. A radar beam pointing directly below a space vehicle will have a circular pattern with symmetrical areas about the center. A beam located off the nadir (the lowest point in the path) will have an elliptical pattern; this asymmetry may be caused

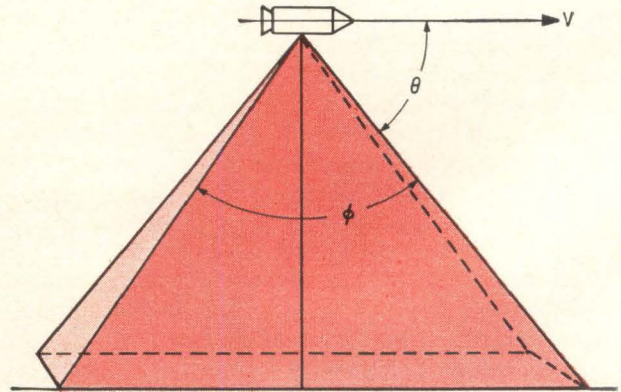
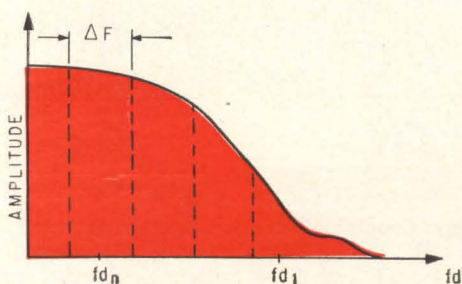
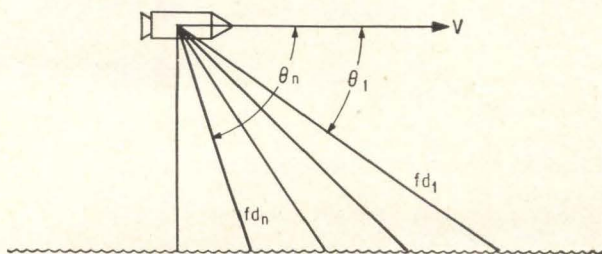

Terrain characteristics can be determined by the amplitude of backscattered radar signals measured within a fan-shaped beam of width ϕ , since different types of terrain reflect different amounts of beam energy. Curves indicating the reflectance profile of the terrain below the spacecraft are obtained by plotting the amplitude of discrete frequencies in wideband doppler returns.

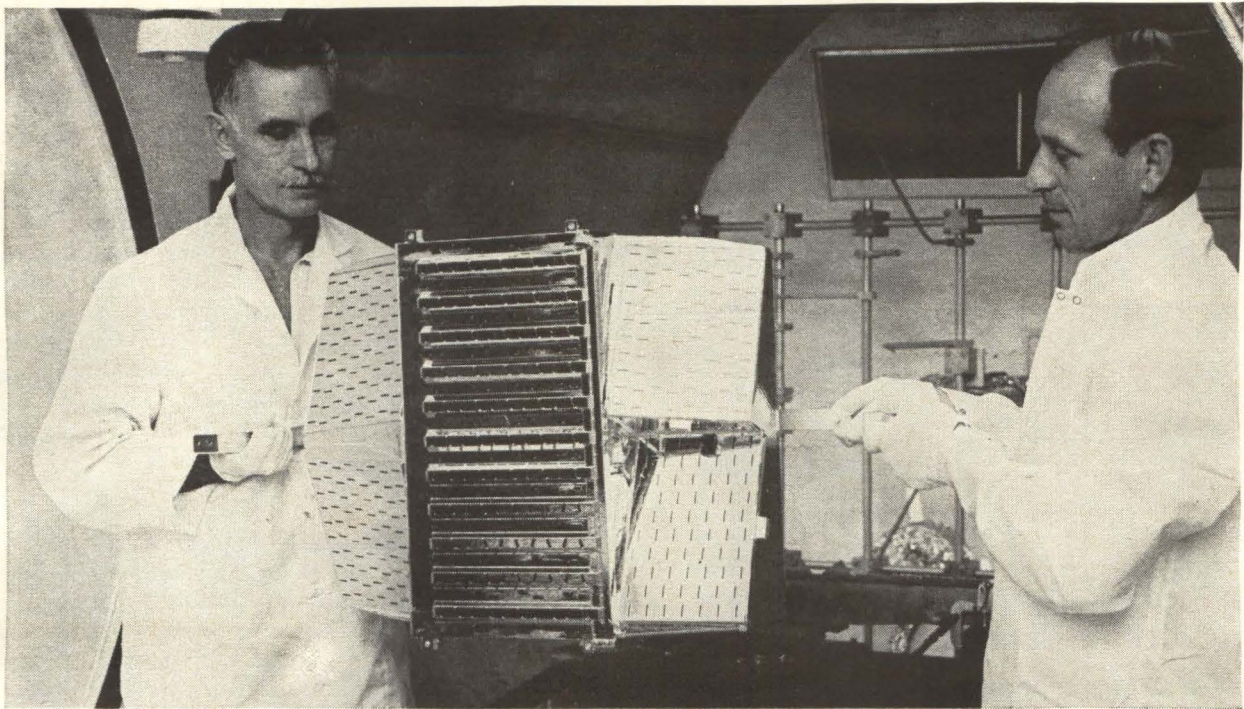

Lunar Module's landing radar antenna gets a coat of heat-resisting aluminum. Radiant electric heaters in a vacuum chamber vaporize aluminum strips and the metal condenses on the antenna.

by a doppler return signal. It is sensed as either an amplitude or phase variation.

The accuracy of a doppler measurement system depends on the position of the centroid (amplitude peak) in the doppler frequency spectrum (f_d), and the centroid's position depends on the reflectivity characteristics of the terrain over which the spacecraft is moving. The basic doppler expression is

$$f_d = \frac{(2V)}{\lambda} \cos \theta$$

where V is the velocity, λ is the wavelength of the transmitted frequency and θ is the beam depression angle—the angle between the spacecraft's direction vector and the radar's aiming point. A second doppler component that contains several doppler frequencies is called the doppler spectrum bandwidth term or

$$\Delta f_d = \frac{(2V)}{\lambda} \sin \theta \Delta \theta$$

The effects of reflectivity on the doppler spectrum is illustrated on page 119. In the left section of the drawing, the reflectivity is uniform and the centroid is located at the nadir. When a typical reflectivity pattern is superimposed on the doppler spectrum, the centroid is shifted off the nadir and this causes an error. Obviously a pencil beam-width would be less susceptible to this type of error. The resultant doppler frequency would be the familiar impulse function rather than the Gaussian distribution of frequencies shown in the upper diagram on page 120. The lower portion

illustrates what would happen if a number of frequency components ($n\Delta F$) in the doppler signal are selected.

Linear frequency modulation techniques select frequencies within the gaussian distribution and superimpose them on each other at frequency F_d to approximate an impulse function. The over-all modulation selection technique is called spectrum compression. The technique of frequency modulating the transmitted wave was developed by the Raytheon Co., and the Laboratory for Electronics Inc. has developed a frequency tracking method. Scientists at the National Aeronautics and Space Administration say that a monopulse radar, with a spectrum compression technique, could guide spacecraft during a mapping expedition in deep space. The sum and difference channels of a monopulse radar can also be used to obtain a narrow power spectrum. This technique provides a narrow doppler spectrum by adding and subtracting the radar returns of two sequentially lobed beams. For a three-axis system, the signals in four beams must be added and subtracted. The Bell Aerosystems division of Textron Inc., has demonstrated the application of the monopulse system to single-beam sensing while the Sperry Gyroscope division of the Sperry Rand Corp. has obtained a narrow doppler spectrum with conical scan techniques.

Remote sensors

It is anticipated that radar systems will play an important role in the geoscience research for earth, lunar, and Martian explorations. Two radar systems being considered are the scatterometer,

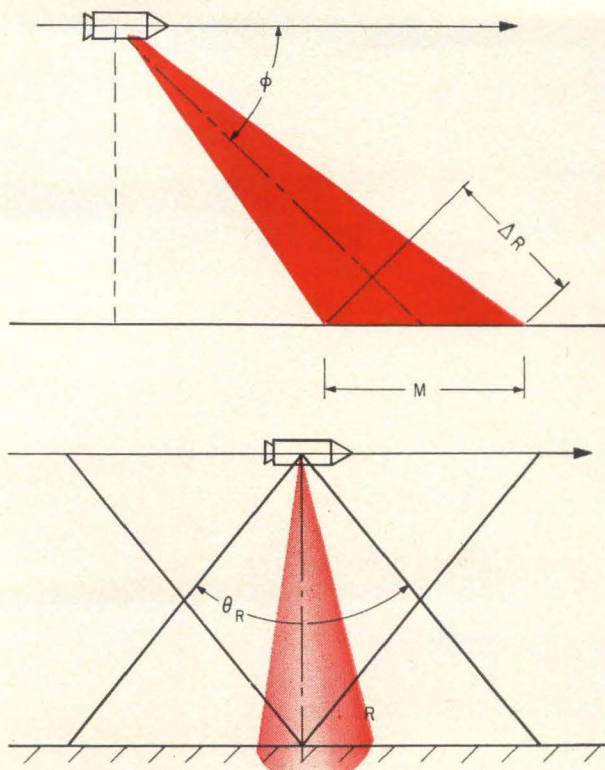

Side-looking radar could map planet as a spacecraft passes over the surface of the moon or a planet.

which will be used to identify surface characteristics, and side-looking radar for mapping.

A scatterometer employs a fan-shaped beam to measure the amount of electromagnetic scattering from various types of terrains. Desert, vegetation, water and other surfaces each have a characteristic radar backscattering coefficient. Explorers will identify terrains remotely by comparing the coefficients of known surface compositions with the backscattering coefficients of unexplored regions.

In a typical scatterometer operation a fan-shaped beam with a beamwidth ϕ illuminates an area and the backscattered signal is measured at several discrete angles, θ , within the beamwidth and plotted.

From the basic doppler expression,

$$f_d = \frac{(2V)}{\lambda} \cos \theta$$

the angle θ is related as

$$\theta_n = \cos^{-1} \frac{(F_d n \lambda)}{2V}$$

when the transmitter frequency and spacecraft velocity are constant.

The wideband doppler frequency return is recorded and divided into discrete frequency intervals by comb filters—filters that provide regularly spaced and equal passbands separated by attenuation bands. The doppler signal amplitude (at each pass frequency) is related to the beam de-

pression angle and is used to draw a graph that identifies terrain over which the spacecraft flies.

A doppler scatterometer has been developed for the NASA Manned Spaceflight Center by the Ryan Aeronautical Co. It will compare earth reflectivity data with lunar reflectivity data obtained from the Surveyor spacecraft to give the Apollo astronauts information about the moon's surface before they set foot on it. NASA is also investigating systems that measure the effects of signal cross-polarization over a wide frequency range (very high frequency to K_a band). A family of these measuring devices—with such features as multifrequency transmission and multipolarization reception and transmission—may be developed to obtain more definitive profiles.

Side-looking radar

To back up the scatterometer, NASA plans to use side-looking radar to locate and map terrain. Existing side-looking radar produces terrain pictures almost as clear as photographs. However, the radar's clarity is affected by frequency, and atmospheric conditions affect radar signals more at some frequencies than at others. Since the exact characteristics of the lunar atmosphere are not known, a multifrequency system will be used.

Since the high velocity of a spacecraft decreases the width of the radar's mapping swath, several orbits of a spacecraft are required to cover the same area normally mapped on earth in a single pass of an airplane. The mapping width (M) is given by

$$M = \frac{R \delta \theta}{2 \cos \phi} \frac{C}{V}$$

The terms $(R\delta\theta)$ defines the lateral resolution in azimuth. For high orbital velocities, V , the effective mapping area decreases with lateral resolution. This is because of the inverse relationship between M and V . For space use, the weight and power consumption of conventional side-looking radar systems must also be reduced and the normal operating periods increased.

The radar's real aperture beamwidth (θ_r) can be effectively decreased by a synthetic aperture antenna. It increases the beam's angular resolution

from $\frac{\lambda R}{D}$ to $\frac{\lambda R}{2L}$ where λ is the wavelength,

R is the range, D is the spacing between array elements and L is the path length of one coherent radar pulse integration. Range resolution is achieved with pulse compression.

Reference

1. R. Broderick, "Radar Applications to Manned Spacecraft," Southwestern IEEE Convention and Show, April 20-22, 1966, Dallas.

The author

Richard F. Broderick is head of the tracking techniques section in the Instrumentation and Electronics division at the NASA Manned Spacecraft Center. He is now studying applications of future radar systems to manned spacecraft.

HIGH CONDUCTANCE DIODES...

- High speed
- High current
- Radiation resistance
- Proven reliability

... from HPA

Reliability and radiation resistance are spelled out in published test results. For your copy and for a data sheet on these specialized Hewlett-Packard high-conductance diodes, call your HP field engineer or write HP Associates, 620 Page Mill Road, Palo Alto, California 94304.

Electrical characteristics at 25°C

Sym.	I_F	BV_R	I_R	C_D	t_{rr}	t_{on}
Characteristic	Forward Current	Breakdown Voltage	Reverse Current	Capacitance	Reverse Recovery Time	Turn-on Time
HP 1001	Min.	500	35	—	—	—
	Max.	—	—	200	1.5	2.5
HP 1002	Min.	800	35	—	—	—
	Max.	—	—	200	3.0	2.0
HP 1003	Min.	300	25	—	—	—
	Max.	—	—	200	2.0	1.5
HP 1004	Min.	600	25	—	—	—
	Max.	—	—	200	4.0	2.0
HP 1006	Min.	500	50	—	—	—
	Max.	—	—	200	1.1	1.5
Units	mA	V	nA	pF	ns	ns
Test Conditions	$V_F=1.4$ V (Note 1)	$I_R=10$ μ A	(Note 2)	$V_R=0$ V, $f=1.0$ MHz	—	—

Note 1: Measured at a repetition rate not to exceed the power dissipation.
 Note 2: $V_R=35$ V for 1006; $V_R=30$ V for 1001, 1002; $V_R=20$ V for 1003, 1004.

2459

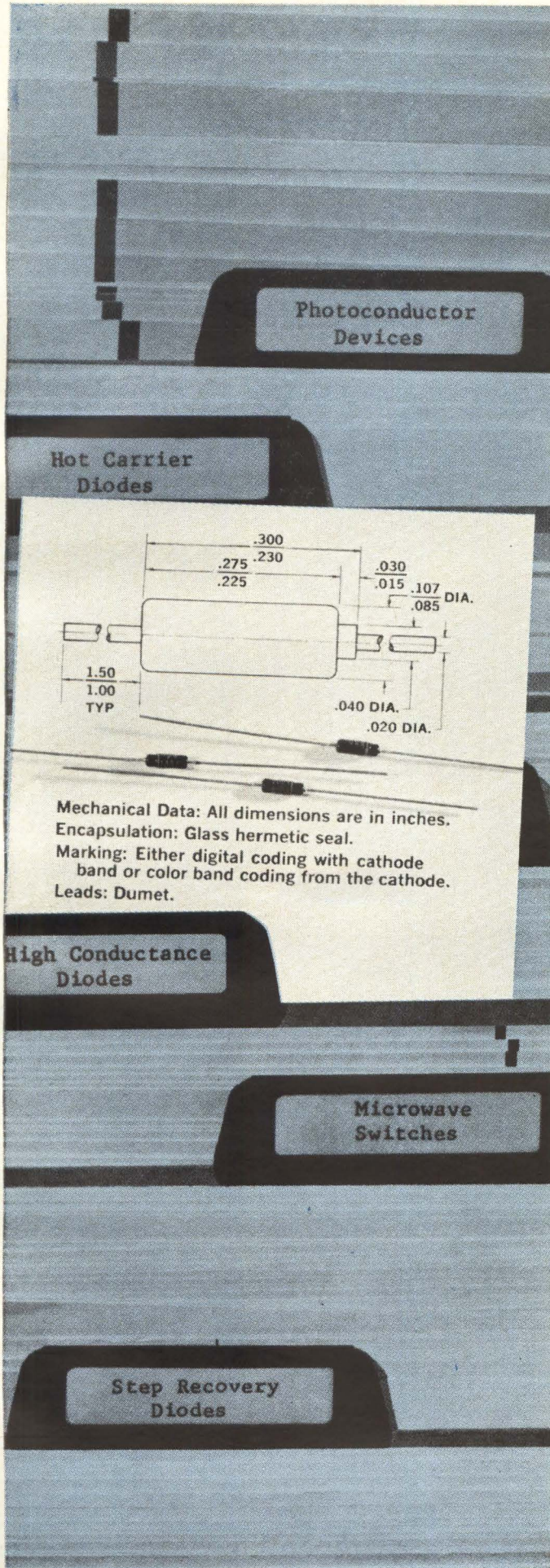

**HEWLETT
 PACKARD**  **HP
 ASSOCIATES**

“Why do more and more executives say MICHIGAN has more of everything?”



“Fast, convenient delivery to half the nation’s population is one big reason.”



Making a good product is one thing — getting it to customers on time is another. Michigan transportation is second to none. Its 1,300 miles of toll-free, multiple-lane, divided highways make possible very rapid delivery, by nearly 1,300 carriers, to 21 major billion-dollar markets. The state’s strategic location also provides easy access to national and international markets via a network of Great Lakes ports, 16 major air carriers, and 25 railroads. More details in confidence? Write:



**Consumers
Power
Company**

Director of Area Development • 216 West Michigan Ave., Jackson, Michigan 49201 • Area Code 517-788-0500

MILLIMETER SYSTEMS



SCALAR FEEDS



FERRITE DEVICES

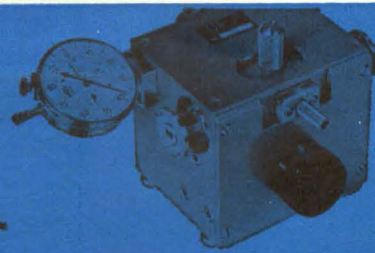

TEST BENCH COMPONENTS

DIRECT READING FREQUENCY METERS



LOW LOSS CIRCULAR WAVEGUIDE COMPONENTS



UNIVERSAL KLYSTRON POWER SUPPLY

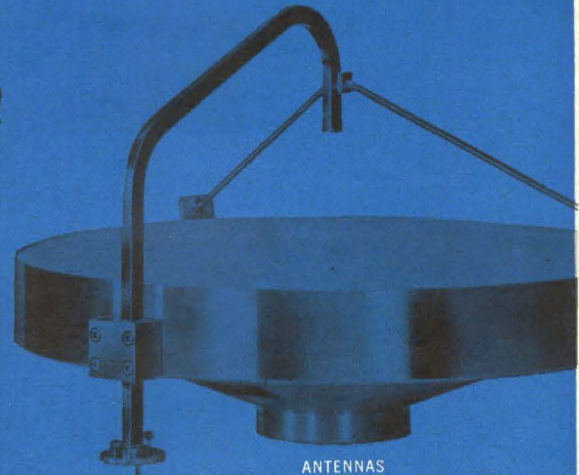
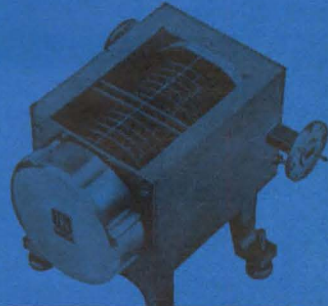

ANTENNAS

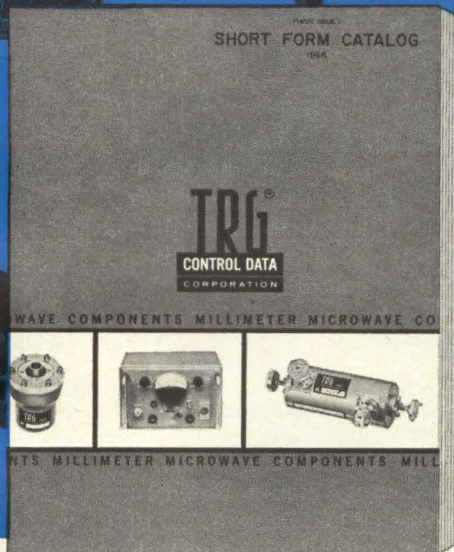

SHORT FORM CATALOG
1964

TRG
CONTROL DATA
CORPORATION

WAVE COMPONENTS MILLIMETER MICROWAVE CO

NTS MILLIMETER MICROWAVE COMPONENTS MILL

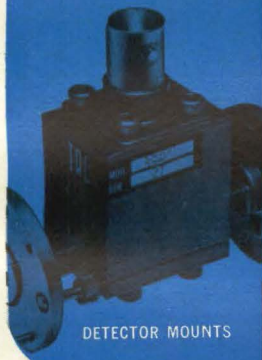

DETECTOR MOUNTS



HARMONIC MIXERS

TRG adds Ku and K bands to its comprehensive line of microwave components (now 12.4 to 220 Gc)...and all the facts are contained in our new short form catalog.



This 20-page, short-form catalog contains all the important specifications on products available for Ku and K bands, as well as A, B, V, E, W, F, D, and G bands. To get your copy, contact your TRG representative or write TRG, 400 Border Street, East Boston, Massachusetts 02128. Tel. (617) 569-2110.

TRG/A Division of Control Data Corporation

Announcing

a new range of digital products for greater design capabilities across-the-board

Now CAMBION® provides digital design engineers an unparalleled source of componentry and hardware to achieve new levels of design speed and capacity. Combining its extensive research background, developmental experience and productive capacity, CAMBION now makes available a diversified selection of over 150 integrated circuit logic assemblies and more than 60 in-line sockets, flat-pack holders and Cambi-Card circuit cards.

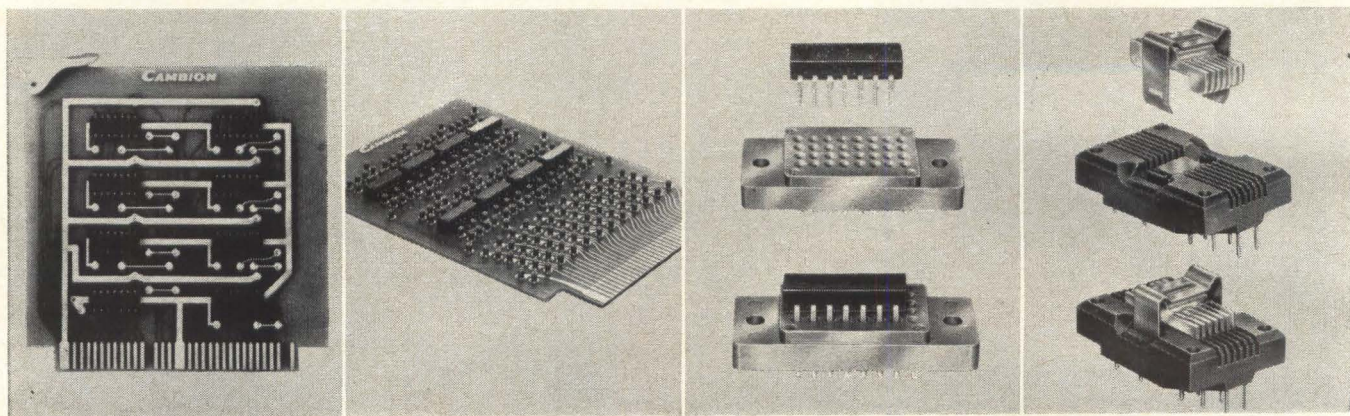

IC Logic Assemblies

With CAMBION's new range of IC logic assemblies, design engineers can begin projects at the systems level. These low-cost, highly flexible units are of *universal* design, comprising a broad selection of logic functions for direct incorporation into data processing, computers, communications and process control systems. CAMBION's DTL (diode transistor logic) integrated circuit logic assemblies are characterized by high speed operation, positive logic levels, low power input, large noise threshold and 70 pin output/-input configuration. Decoders, counters, shift registers, etc. . . . you'll find them all in CAMBION's new line of IC logic assemblies.

Cambi-Cards

CAMBION Cambi-Cards provide the engineer developing his own logic systems with the most versatile mounting hardware for all integrated circuits. CAMBION currently offers a series of 20 different Cambi-Card circuit boards that permit the flexible interconnection of 8 or 16 integrated circuit packages per board, including in-line sockets, flat-pack holders and TO-5 cans. These boards are offered with many jack and terminal combinations, permitting a variety of hardware or jumper interconnections of circuit functions.

IC Sockets & Holders

CAMBION Sockets are designed to accept all in-line IC packages, with up to 32 pin capability. Jacks, with cage or flat spring inserts, are engineered to survive thousands of insertion/extraction cycles. The reverse ends of both jack styles (flat or round pins) are available with solder terminal, solder pot, Wire-Wrap* or pin/plug.

CAMBION Holders, with either round pin/plug or Wire-Wrap contacts, can accept any standard flat microelectronic package with 14 pin configuration. These flat-pack holders are easy to handle, precision crafted and give reliable electrical contact.

© Reg. U. S. Pat. Off.

*T. M. Gardner-Denver Co., Reg. U. S. Pat. Off.

This wide selection of IC logic assemblies and accessories affords design engineers exceptional economy and flexibility in prototyping and production, parts and systems testing, inspection of incoming parts, and general breadboarding applications.

Send for FREE descriptive literature today. See how this new range of tools can expand the spectrum of your digital design capabilities. Write to Cambridge Thermionic Corporation, 510 Concord Avenue, Cambridge, Massachusetts 02138. Phone: (617) 876-2800. In Los Angeles, at 8703 La Tijera Boulevard 90045. Phone: (213) 776-0472.

CAMBRIDGE THERMIONIC CORPORATION
CAMBION®

Standardize on CAMBION . . . 21,541 guaranteed electronic components

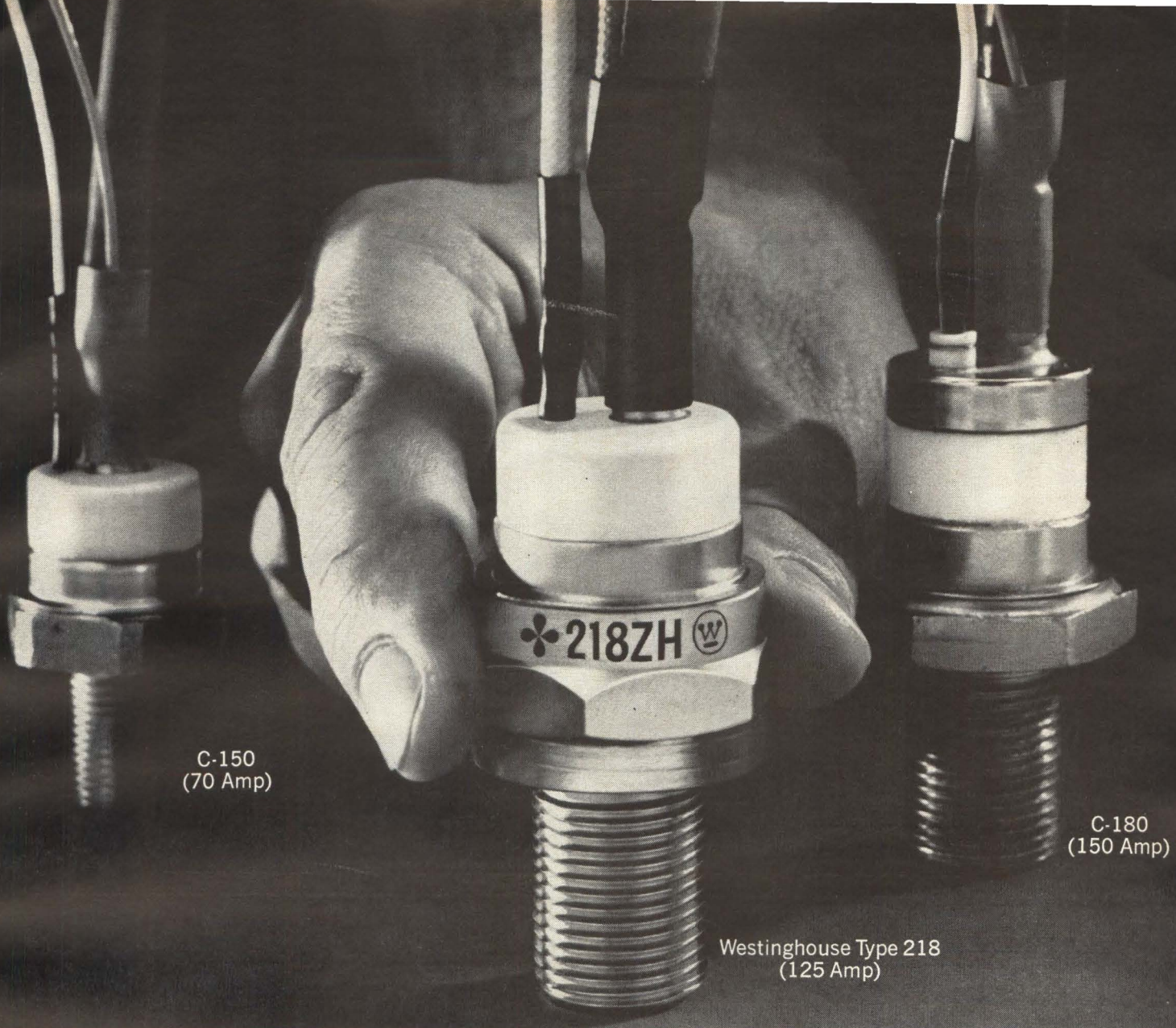

C-150
(70 Amp)

C-180
(150 Amp)

Westinghouse Type 218
(125 Amp)

Now Westinghouse fills the thyristor amp gap

With the new Westinghouse 125 amp thyristor — Type 218 — you can stop paying for 150 amps just to fill 70 to 125 amp applications.

What's more, the Type 218 gives you a 3,300 amp surge rating—45,000 ampere² seconds — even better than many 150 amp thyristors! Voltage ratings through 1400 volts, dv/dt rating of 100 volts per microsecond, and a typical turn off time of 40 microseconds offer greater design flexibility. 20 microseconds turn-off

time available by request.

Key to this unusual performance is the exclusive Westinghouse C. B. E. design (Compression-Bonded Encapsulation). By eliminating solder joints, this construction ends thermal fatigue, greatly reduces thermal impedance.

Such features make possible the unique Westinghouse lifetime guarantee. On the Type 218, and other semiconductors, this symbol  on the case means that the guarantee applies.

For immediate delivery on Type 218,

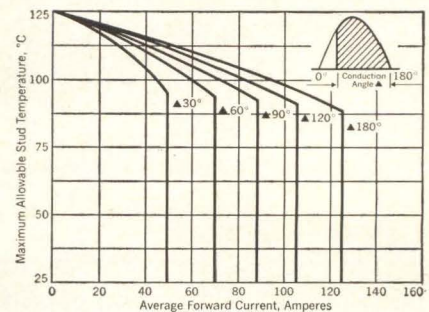

Current capability of Westinghouse
Type 218 Thyristor

just call your local Westinghouse distributor. For detailed technical data, write: Westinghouse Semiconductor Division, Youngwood, Pa. 15697.

You can be sure if it's Westinghouse



SC 2077



Westinghouse warrants to the original purchaser that it will correct any defect or defects in workmanship, by repair or replacement f.o.b. factory, for any silicon power semiconductor bearing this symbol  during the life of the equipment in which it is originally installed, provided said device is used within manufacturer's published ratings and applied in accordance with good engineering practice. This warranty shall constitute a fulfillment of all Westinghouse liabilities in respect to said products. This warranty is in lieu of all other warranties expressed or implied. Westinghouse shall not be liable for any consequential damages.

the
Nation's
GROWTH
INDUSTRIES
are
taking
a hard
look
at
MINNESOTA

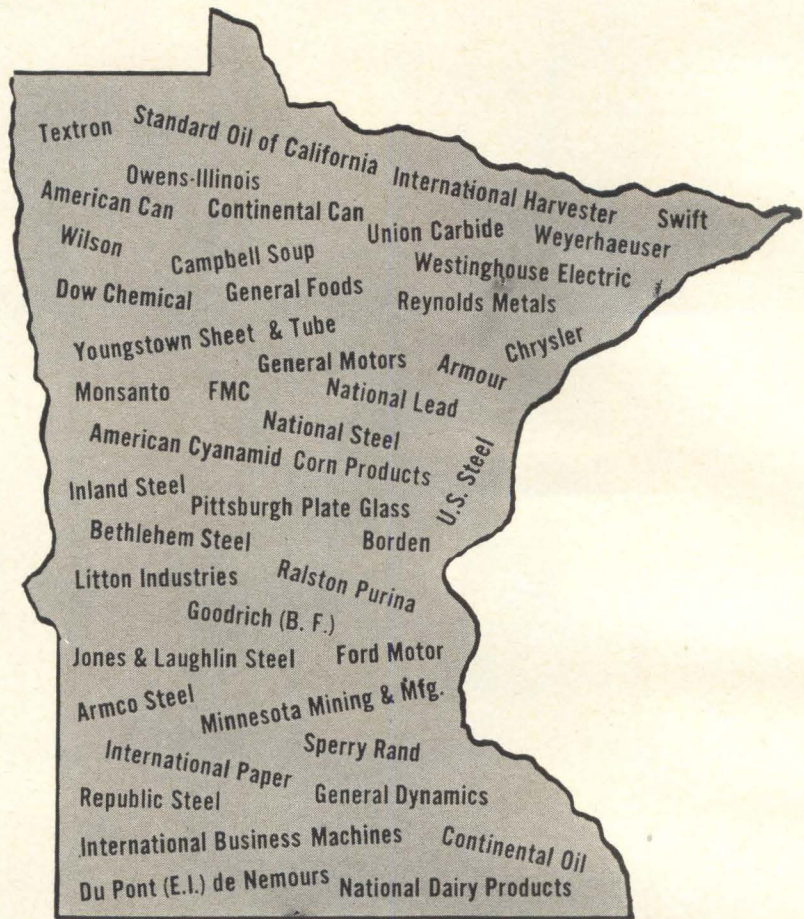

45 of FORTUNE Magazine's "top 100" corporations operate 120 plants in Minnesota. These industries find Minnesota is on the move!

A good hard look at Minnesota reveals a fine, creative work force with skills to meet any degree of sophistication.

Minnesotans believe in the wisdom of investing in people. That's why so many Minnesotans complete high school or one of Minnesota's many trade schools. Minnesota enjoys the distinction of being one of the leading states in the number of Ph.D.'s per million population.

Minnesota's investment in people can pay off handsomely for any company depending on intel-

ligent, skilled, self-reliant employees . . . employees who welcome responsibility, who take pride in their work!

Minnesota is the marketing, financial and transportation hub of the Upper Midwest and Northwest economic regions. Minnesota enjoys a unique location that is commanding a hard look from the Nation's fastest growing industries.

Lastly, a good hard look at Minnesota will reveal unlimited cultural and recreational opportunities for employees . . . from the cosmopolitan atmosphere of her cities to the soul-stirring beauty of her virgin wilderness.

If you want to take a good hard look at Minnesota, call or write:

DEPARTMENT OF BUSINESS DEVELOPMENT
Division 14P, State Capitol
St. Paul, Minnesota (55101)



30-gage wire can't have much insulation

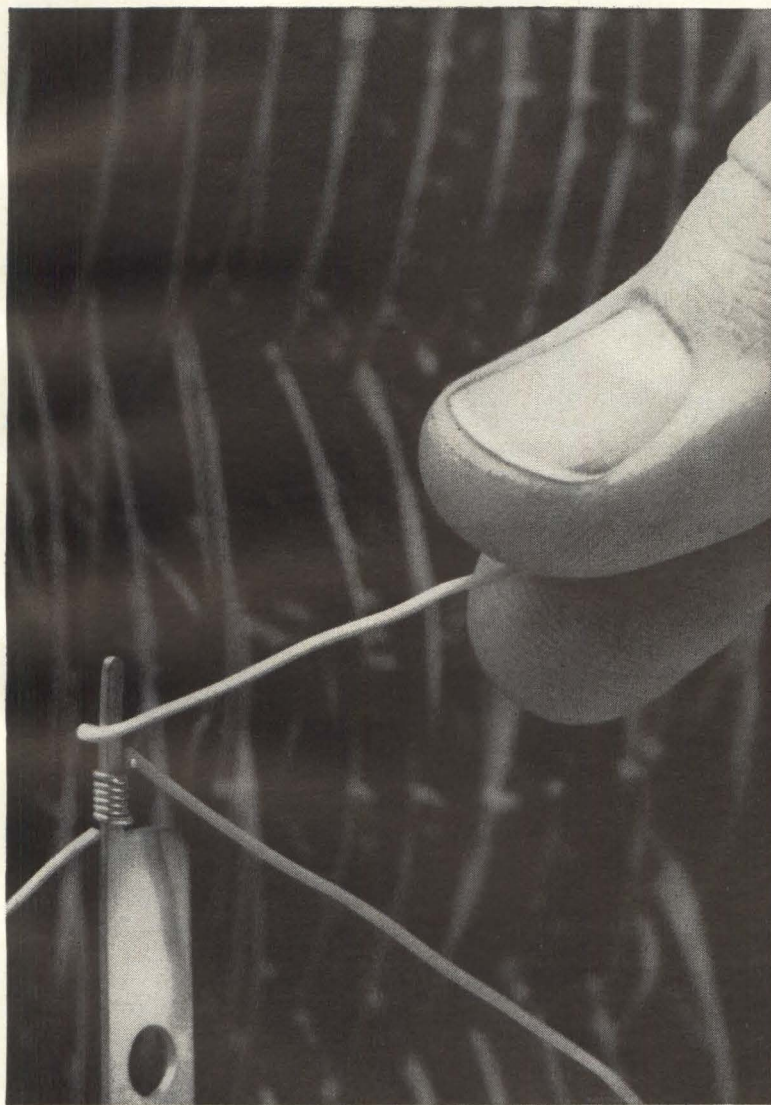

**It's got
to be tough**

**That's why
it's Kynar[®]**

Kynar has superior cut-through and abrasion resistance . . . double the mechanical strength of other fluoro-plastic insulations. It withstands bending . . . vibration . . . resists cleaning solvents . . . operates from -80° to 300°F . . . feeds, cuts and strips smoothly in hand and automatic wiring machines.

Wire insulated with Kynar is available from leading manufacturers. For data, write or call Plastics Department, Pennsalt Chemicals Corporation, 3 Penn Center, Philadelphia, Pa. 19102.

Kynar...the fluoroplastic that's tough!

PENNSALT

new Tektronix plug-in simplifies reflectometry measurements

Type 1S2 Sampling Unit for time domain reflectometry and general-purpose sampling

You can test transmission lines, cables, connectors, broad-band devices with ease and accuracy with the new Type 1S2 Sampling Plug-In Unit. It can be used in any Tektronix oscilloscope that accepts letter and 1-series plug-ins.

The ≤ 90 -ps risetime of the vertical channel, and deflection factors to 5 mV/div make the Type 1S2 useful in many general-purpose sampling measurements. For this general-purpose use, a pretrigger or delay line is required. System risetime as a reflectometer is ≤ 140 ps.

The illustration shows a Type 1S2 in a Tektronix Type 549 Storage Oscilloscope being used to test a 50- Ω delay line. Information obtained from the upper trace includes electrical length of the line, nominal impedance, location and type of discontinuities. Lower trace is magnification of the discontinuity shown near the center of the upper trace. Deflection factors:

Upper trace — Vertical 0.25 p/div
Horizontal 20 ns/div
Lower trace — Vertical 0.025 p/div
Horizontal 5 ns/div

The Type 1S2 Manual Scan display mode was used in storing both traces to obtain optimum resolution.

With the Type 1S2, positions of discontinuities in a line under test can be read directly from a dial in units of time or distance. Accuracy of round-trip time readings is within $\pm 1\%$ of full scale.

Dual, full-scale 10-division horizontal calibration is in distances of 10 m, 100 m, and 1 km, and in times of 0.1 μ s, 1 μ s, and 10 μ s. The display can be expanded by a 7-step, calibrated, X1 through X100 magnifier for detailed examination of any discontinuities.

Illuminated readout of the horizontal scale factor, including any magnification, adds to the operating ease. And testing of either short or long lines is facilitated by internal generators that provide a 50-ps, 250 mV pulse and a 1-ns, 1-V pulse.

A front-panel switch provides for matching the horizontal calibration to the types of lines most commonly tested—air, TFE, and polyethylene. A variable control permits matching the calibration to lines using other dielectrics.

Vertical calibration is in both ρ (rho) and in volts, from 0.005/div to 0.5/div, in 7 steps, with an accuracy within $\pm 3\%$. It is also variable between steps, uncalibrated. A ± 2 -V offset voltage, monitorable at the front panel, allows amplitude measurements, using slide-back techniques, with an accuracy within $\pm 1\%$.

Vertical and horizontal outputs of 1 V/div of displayed signal are available at front-panel connectors.

Type 1S2 \$1300
Includes: 2X and 5X attenuators, 50- Ω termination, 20-cm airline, 5-ns RG 8/AU cable, 2 GR elbows, 18" patch cord, and 2 manuals.

U. S. Sales Price f.o.b. Beaverton, Oregon

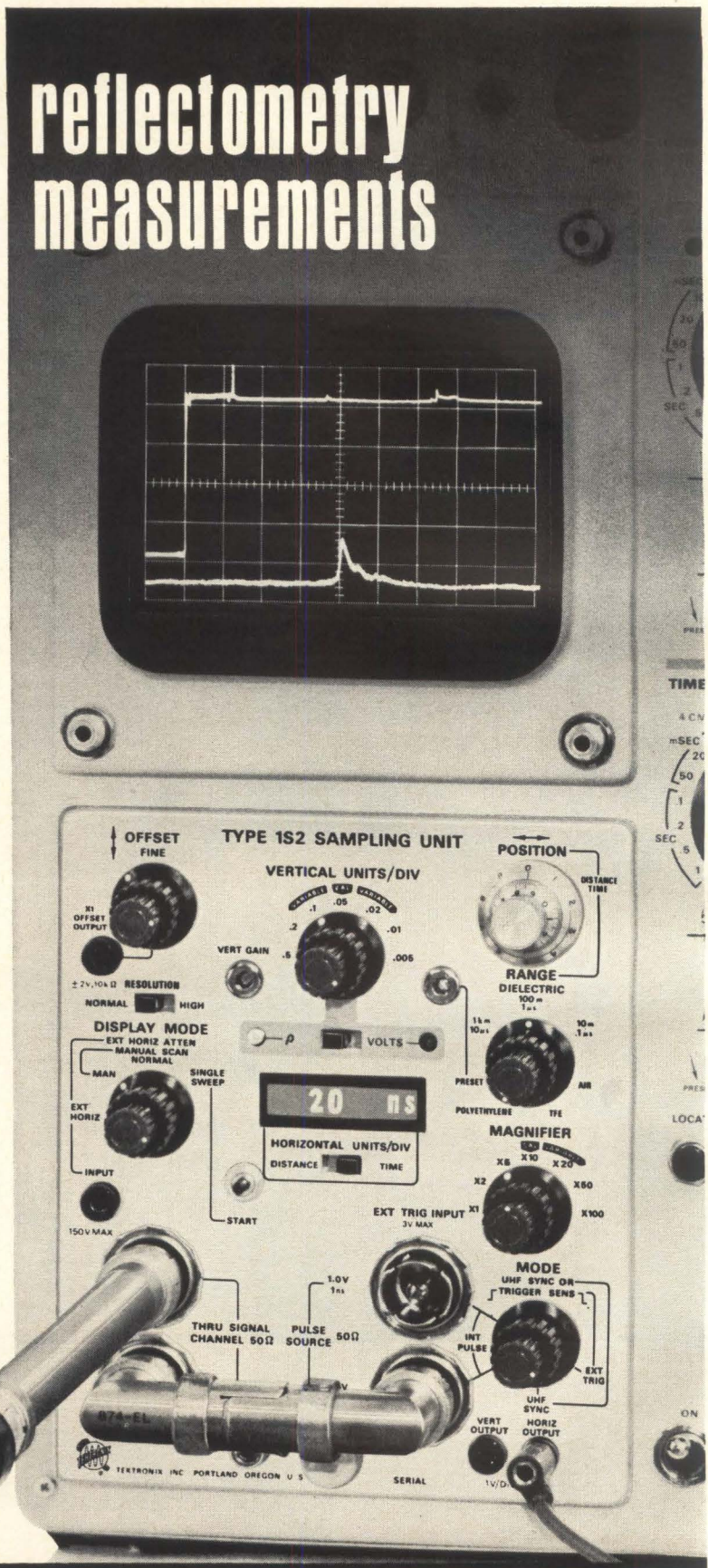

Tektronix, Inc.



For complete information, contact your nearby Tektronix field engineer or write:
Tektronix, Inc., P.O. Box 500, Beaverton, Oregon 97005

Helipot dials

help your panels put up a good front

Here's something you ought to think about. A lot of your effort, and a bundle of dough, goes into the circuitry behind the panel. Is \$4.50 asking too much to make it look better up front? We don't think so, and a lot of people seem to agree. Or else they wouldn't have made Helipot's Duodial® turns-counting dials the most widely used in the industry. There are two reasons: they look better and work better than the rest.

The design considerations you can see for yourself... gleaming satin chrome finish, black nylon knob, and precision machined cover. (Can you name any other manufacturer who *machines* the dial cover?) The mechanical advantages may not be quite so obvious, but they're there. If you turn the knob, you can *feel* the quality. Helipot dials are precision components that provide setting accuracy with a minimum of play and zero backlash. They're easier to read, too, because we've put big numerals in a wide window. That means you get maximum viewing angle and can see ad-

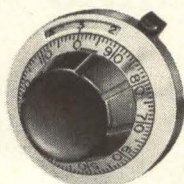

RB SERIES - 15 turn, 1-13/16" diameter - 5 standard models, priced as low as \$4.50 in quantity.



2600 SERIES - 15 turn, 7/8" diameter - 3 standard models, priced as low as \$6 in quantity.

jacent numbers and direction of travel. (Compare this with the dials that have tiny peek-a-boo windows.) Even the Helipot locking mechanism is to your advantage. Unlike other dials, the Helipot locking lever is independent of the knob so you won't disturb the dial setting when you lock it. We thought of just about everything - so you wouldn't have to.

Here's another reason economical Helipot dials make good sense: your local Helipot sales representative stocks them by the *thousands*, so you can have same-day delivery when you need it. Call Helipot now for information on the complete dial line, including new digital dials.

Beckman®

INSTRUMENTS, INC.

HELIPOT DIVISION

FULLERTON, CALIFORNIA • 92634

INTERNATIONAL SUBSIDIARIES:
GENEVA; MUNICH; GLENROTHES, SCOTLAND; TOKYO; PARIS; CAPE TOWN; LONDON; MEXICO CITY

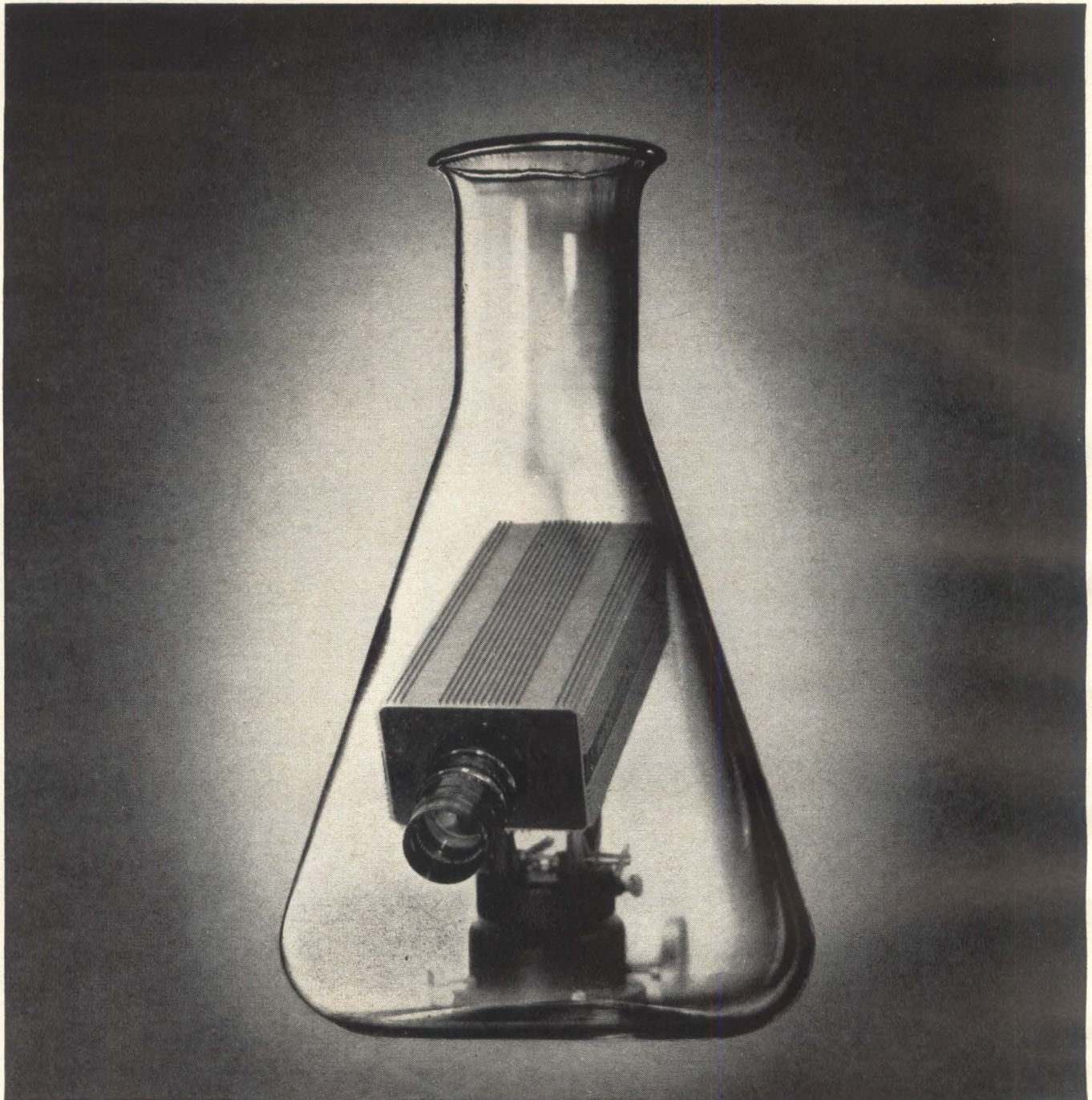

RESEARCH HAS A NEW TOOL

To date there are over 1000 known applications of closed circuit TV. The unknown are in the millions, but scientists are discovering new uses every day — as are we.

MTI camera equipment has become the accepted standard in the medical field. And the reasons are as simple as the equipment is to operate. A flip of the switch gives you 7 day - 24 hour continuous operation with no adjustment. Compact, lightweight, completely

reliable — you have perfect viewing instantaneously. MTI equipment needs no special "studio lighting" — no special staff.

It's a new tool — a valuable new tool in research. So may we suggest that if you have an application — known or unknown — call or write:

mti MARYLAND TELECOMMUNICATIONS, INC.
York & Video Roads, Cockeysville, Md. 301 - 666-2727
World's largest manufacturer of low light level television cameras.



WAVETEK uses Allen-Bradley Type F variable resistors exclusively because of their

- * Quality performance
- * Excellent stability
- * Infinite resolution

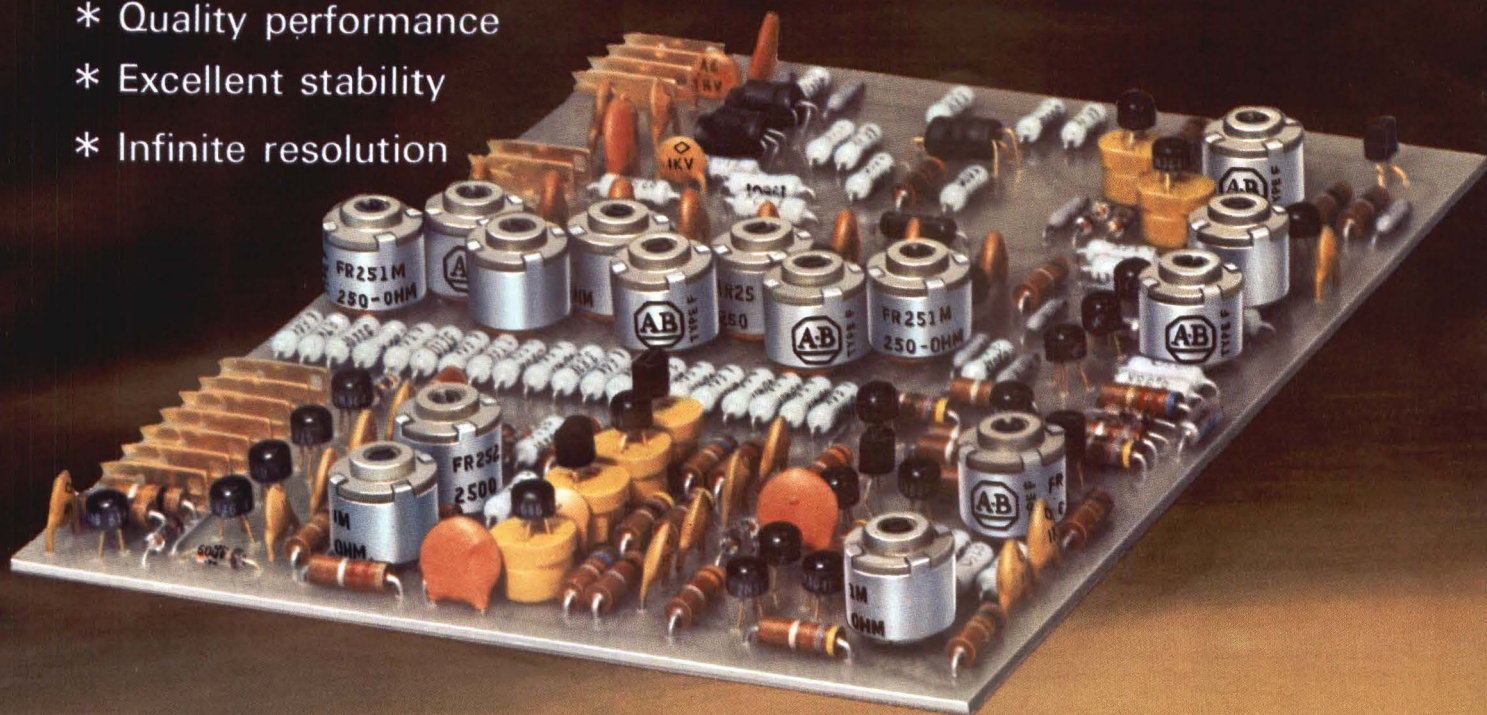

One of the 5-inch by 6½-inch Wavetek printed circuit cards, showing 15 of the 25 Allen-Bradley Type F hot molded variable resistors and numerous hot molded fixed resistors used in the Model 111 VCG function generator.

Type F variable resistor with pin type terminals for mounting directly on printed wiring boards. Rated ¼ watt at 70°C. Total resistance values from 100 ohms to 5 megohms.

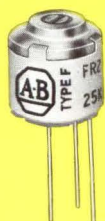

Actual Size



Wavetek Model 111 VCG generates sine, square, triangle, and ramp waves from 0.0015 Hz to 1 MHz, and offers precision control of the frequency of the waveforms by external voltage.

■ The precision waveforms generated by Wavetek's Model 111 VCG place exacting demands on the large number of variable resistors used to set amplitudes to very precise values and assure symmetry of all functions. They must provide velvet smooth control, and quiet operation. And since this is a Wavetek adjustment, it is essential that the variable resistors, once adjusted, will stay "put".

Allen-Bradley Type F variable resistors satisfy all of these requirements, because they have the same solid hot molded resistance track as the famous Type J and Type G variable resistors. There's velvet smooth control at all times—never the problem of discrete steps com-

mon to all wire-wound units. And since Type F variable resistors are essentially noninductive and have low distributed capacitance, they can be used at high frequencies where wire-wound controls are useless.

When a manufacturer like Wavetek has standardized on the quality of A-B electronic components, you can be sure of the superior performance of such equipment.

For more details on the complete line of Allen-Bradley quality electronic components, please write for Publication 6024. Allen-Bradley Co., 222 W. Greenfield Avenue, Milwaukee, Wis. 53204. In Canada: Allen-Bradley Canada Limited. Export Office: 630 Third Avenue, New York, N.Y., U.S.A. 10017.



ALLEN-BRADLEY

QUALITY ELECTRONIC COMPONENTS

An Allen-Bradley announcement of importance to motor designers

The new MO6-C ferrite magnet having 30% higher intrinsic coercive force

■ The new Allen-Bradley MO6-C ceramic permanent magnets provide at least 30% increase in the highest previously available intrinsic coercive force—obtainable with A-B's MO5-C material. This advance is achieved with the same high residual flux density.

Designers of permanent magnet motors have a choice of these advantages—30% higher resistance to demagnetization, or 30% increase in motor output, or 30% increase in cold temperature protection. In fact, where the higher coercive force is not required, the designer can give himself a 30% reduction in magnet size.

This new Allen-Bradley MO6-C material opens the door to such motor designs where permanent magnets heretofore were not practical, namely for motors used in many portable tools and appliances. Like with the MO5-C material, these new MO6-C magnets are radially oriented, and are available in virtually all sizes and shapes currently being produced in segments for motors from 3/4" diameter to 10 hp. While MO5-C magnets will continue to satisfy most needs, MO6-C enables designers to satisfy more exacting motor design requirements because of its unusually high intrinsic coercive force.

Allen-Bradley application engineers will be pleased to help you obtain maximum economy in your motor design through optimizing magnet performance. Please let us hear from you. Allen-Bradley Co., 222 West Greenfield Avenue, Milwaukee, Wisconsin 53204. In Canada: Allen-Bradley Canada Limited. Export Office: 630 Third Ave., New York, N.Y., U.S.A. 10017.

TYPE MO6-C CERAMIC PERMANENT MAGNETS

Typical Characteristics

—stated values have been determined at 25°C.

Property	Unit	Nominal Value
Residual Induction (B_r)	Gauss	3300
Coercive Force (H_c)	Oersteds	2800
Intrinsic Coercive Force (H_{ci})	Oersteds	3100
Peak Energy Product ($B_d H_d \max$)	Gauss-Oersteds	2.5×10^6
Reversible Permeability	—	1.09
Curie Temperature	+°C	450
Temperature Coefficient of Flux Density at B_r	%/°C	-0.20
Specific Gravity	—	4.9
Weight per Cu. In.	Lbs.	0.177

ENERGY PRODUCT $B_d H_d \times 10^6$ 2.5
3.0 | 2.0

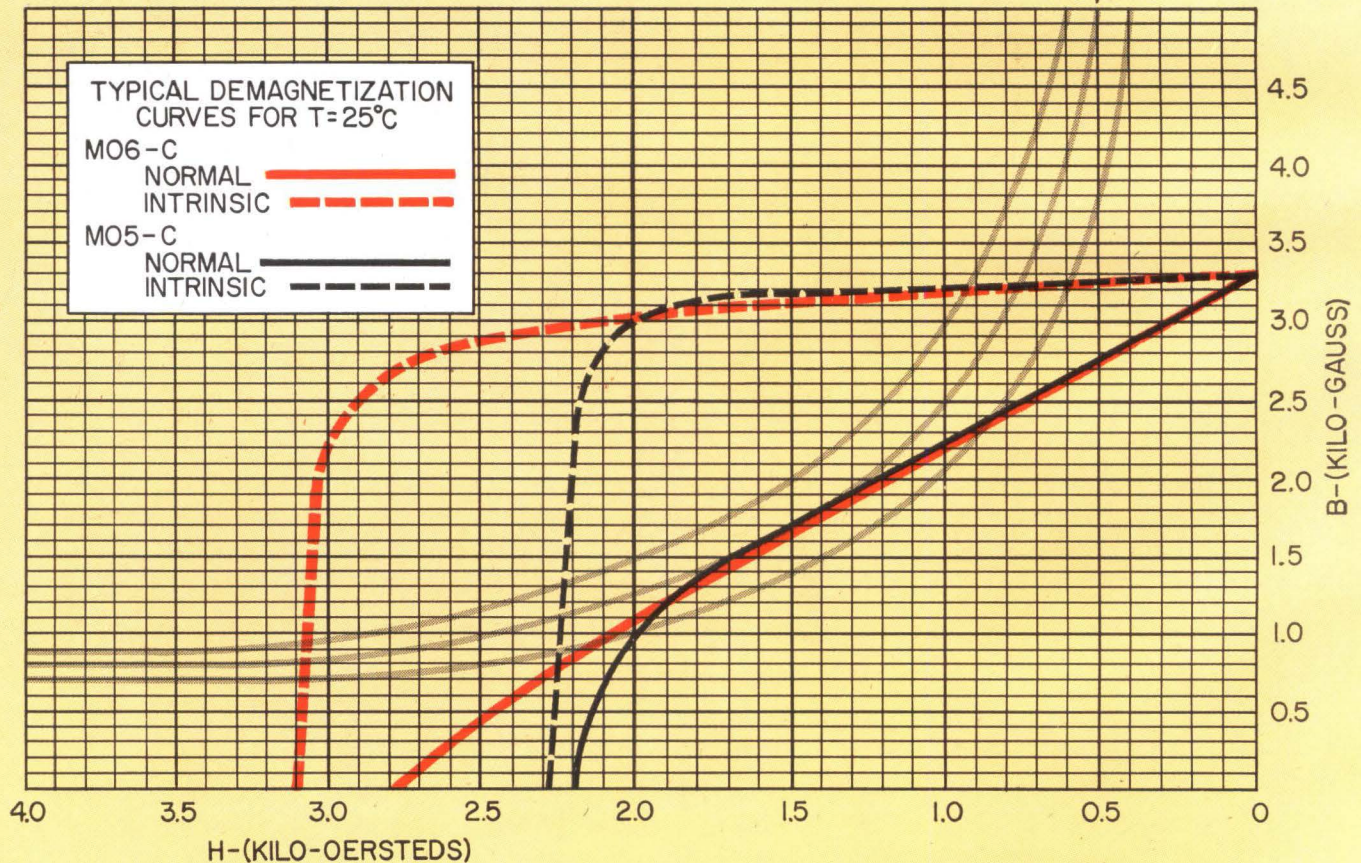

ALLEN-BRADLEY

QUALITY MOTOR CONTROL
QUALITY ELECTRONIC COMPONENTS

TRW Capacitors



...help report history as it happens.

Nearly everyone looks to TRW capacitors when he wants to build better communications systems. From space transmissions to cross-town phone calls, when man has

something to say, capacitors from TRW help him say it better.

Product information is available from TRW Capacitor Division, TRW INC., Box 1000, Ogallala,

Nebraska. Phone (308) 284-3611
TWX: 910-620-0321.

TRW

Just \$75 Buys You This Tiny, Adjustable TRIMPOT® Time-Delay Relay

Now—low price, small size and adjustability all in one! You can easily fit the Model 3908 industrial time-delay relay into both your system and your budget. With just a screwdriver, you can adjust it accurately over a range of 0.1 to 1.5 seconds; and by adding an external resistor or resistor-capacitor combination, you can boost the time delay to 200 seconds while retaining the adjustment feature. In addition, you can mount it in just one square inch and operate it continuously on less than 0.06 amps.

The Model 3908 is potted and has all-welded, solid-state circuitry. It is protected against operating-voltage transients. Even in the most difficult industrial applications, it performs with full Bourns reliability.

Bourns also offers you two MIL-SPEC subminiature time-delay relays, Model 3900 (DPDT) and Model 3907 (SPST NO-Solid State). All units are available from stock. Write TODAY for complete technical data!



MODEL 3908
Industrial Unit



MODEL 3900
MIL-SPEC Unit



MODEL 3907
MIL-SPEC Unit

Time-delay range:	0.1 to 200 secs.	0.1 to 200 secs.	0.1 to 200 secs.
Environment:	Industrial	MIL-R-5757D	MIL-R-5757D
Size:	1.0" x 1.0" x 0.7"	0.4" x 0.8" x 1.31"	0.4" x 0.8" x 1.0"
Output:	DPDT relay 1.0A resistive at 26.5 VDC, 85°C	DPDT relay 1.0A resistive at 26.5 VDC, 120°C	SPST NO—solid state 0.05A resistive at 26.5 VDC, 120°C
Nominal Voltage:	20 to 30 VDC	20 to 30 VDC	20 to 30 VDC
Operating Temp. range:	−40 to +85°C	−55 to +120°C	−55 to +120°C



BOURNS, INC., TRIMPOT DIVISION
1200 COLUMBIA AVE., RIVERSIDE, CALIF.
PHONE 684-1700 • TWX: 714-682 9582
CABLE: BOURNSINC.

Probing the News

Military electronics

Troubleshooting in trouble spots

Army school uses lessons learned in Vietnam action to train corps of repairmen for fire-control systems aboard helicopters

Fighting helicopters, bristling with armament they were never designed to carry, have more than proved their worth in Vietnam. But problems in the electronic fire-control systems aboard these weapons platforms are just now coming to light. Reports on failures and malfunctions are fed back from operational units all over the world to the Aircraft Repairmen's school run by the Aberdeen Proving Ground in Maryland.

Capt. A.J. Larkin, chief of the school's Aircraft Armament branch, studies these reports so repairmen can be drilled on what to expect and how to troubleshoot effectively. "It's a real challenge to keep up with this quickly changing field," Larkin says. "We're getting more systems that are more complex and more electronic," he reports.

From 30 to 35 helicopter armament repairmen are graduated each week. The men must work hard since the whole course, including basic electronics, lasts only 17 weeks. They are taught to install, test, maintain and repair the six armament systems the Army uses aboard its two armed helicopters—the UH-1D transport and the UH-1B escort.

What's new. Beginning next month, the minigun for the Light Observation Helicopter will be added to the curriculum. In June, there will be new courses on five systems for the HueyCobra, which will be sent to Vietnam later this year. This fast, sleek chopper is the first built to operate specifically as a striking weapon. It will carry over a ton of ordnance, including two rocket launchers, a 40-millimeter grenade launcher, a minigun and mine dispenser.

Four weapons systems now used on the older Hueys already in Vietnam are being tested on the big Chinook copter. When they prove satisfactory, the school will coach its men on how to handle any difficulties arising from installation of the systems on a different aircraft. Later, there will be courses on a whole generation of new gear for Aafss, the advanced aerial fire support system that the Lockheed Aircraft Corp. is developing.

Before matriculating at Aberdeen, the students receive only eight weeks of basic training. The men now finishing up are 19 to 20 years old and have been through high school. Due to the Vietnam buildup, the new men coming in have much less formal education. Making these men satisfactorily proficient is a challenge for industry as well as the Army since the tools and techniques of armament maintenance must be made simpler and more reliable as must the equipment itself.

I. Grenade launcher

An elaborate system with a minimum of headaches is the M5 40-millimeter grenade launcher. Mounted on the nose of a UH-1B helicopter, the M5 can fire at a rate of up to 230 rounds per minute as far as 2,700 meters—1½ nautical miles. The weapon is used against personnel, convoys, machine gun emplacements and soft buildings.

The launcher and grenade turret outside can be moved from inside the cockpit by the copilot gunner who uses a reflex sight. Impulses generated by moving the sight are converted by a servoamplifier to signals that activate the mechanism to swing the launcher laterally and vertically.

Repairmen complain about the servoamplifier junction-box assembly. This unit has two amplifier module assemblies, a control module, and relay switching and control circuits for the subsystem. The control servoamplifier module, the men

Launcher portion of minigun-rocket system used on UH-1B helicopters is inspected by instructors at Aircraft Repairman's school.

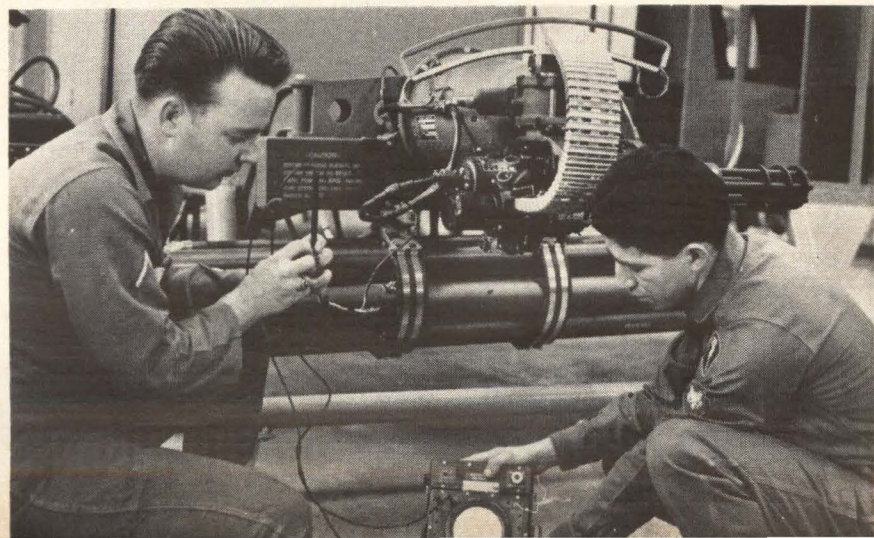

SIZE

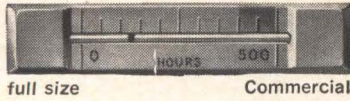

full size

Commercial

WEIGHT

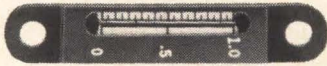

full size

MIL-I-81219(WP)

POWER



full size

Commercial

COST

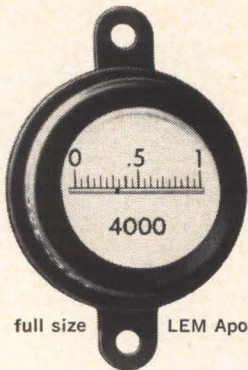

full size

LEM Apollo

Four Good Reasons to consider Curtis Elapsed Time Meters

Curtis Instruments, Inc.

351 Lexington Avenue, Mt. Kisco, N. Y.

Phone: 914-666-8051

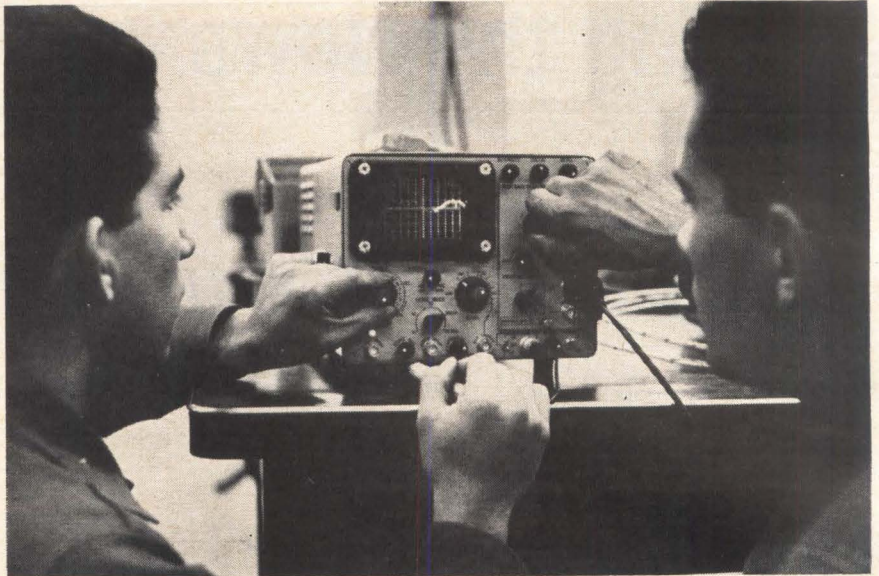

Trainees at the Aircraft Repairman's school check out subsystem with oscilloscope. The 17-week curriculum includes a course in basic electronics.

say, must be sent back to the depot for repair. Because spares are often unavailable, they feel these two modules should be designed for repair in the field.

Plus side. The assembly has its good points, however. It is mounted on the rear section of the helicopter where it can be easily reached from the baggage compartment. In addition, test jacks are externally mounted on both sides of the axial blower which permits electrical troubleshooting without removal of the cover assembly.

The loading switch on the ammunition-booster drive motor, mounted on a shelf inside the electronic equipment compartment of the copter, must be improved. Repairmen say the quality of the switch is poor and it frequently burns out. "If you don't have a spare, the gunner has to pull the heavy cartridge links from the ammunition box through the whole assembly by hand," says one.

There is also a major problem in the sight-mount bracket, which is secured to a plate on the helicopter structure above and slightly behind the copilot's head. The wire in the hand control and sight assembly is fragile and is weakened by slewing the sight to the left or right or by changing its elevation. When failure occurs, control of the whole weapons system is lost.

There are also complaints about the inflight test set for the grenade launcher. Repairmen at Aberdeen claim this unit isn't rugged enough

to survive the shaking it gets in a helicopter. The test synchro often goes out of calibration, which, of course, makes the unit useless for calibrating the system. Finally, the men would like to repair the test set in the field, but it, too, must be sent to a depot.

The launcher and the test set were built by the General Electric Co. with the Sperry Utah Co., a division of the Sperry Rand Corp., a secondary source for the launcher. Each launcher costs close to \$42,000; the test set, \$38,000.

II. Guided missile

The big complaint about the M22 wire-guided missile is that it's made in France and spare parts are hard to obtain; components from the United States can't be substituted. According to instructors at Aberdeen the construction characteristics of the French transistors are not even known in the U.S.

The M22 missile is an airborne assault weapon used to support frontline troops. Primarily an anti-tank weapon, it is also effective against such targets as fortified gun emplacements and bunkers. The system has six missiles carried on and fired from boom assemblies attached to the helicopter. Missiles are fired and remotely controlled by the copilot gunner, firings can be made while the chopper is flying, hovering or on the ground.

The gunner operates an airplane-type control stick that provides the

basic pitch and yaw command signals. Basic commands are converted to coded electronic guidance signals and transmitted to two trailing wires on the inflight missile. The signals are then routed to the appropriate control devices.

The missile weighs 64 pounds, is 4 feet long, has a course speed of 400 miles per hour and flies for 22 seconds with a maximum range of 3,500 meters—1.85 nautical miles.

Fragility is a problem with the missile sight. The mechanical stops often break when the sight is swing from left to right. In addition, the control amplifier for the sight is a throwaway item, though the men would like to be able to repair it.

Time sharing. The missile's command operations function (COF) tester has, according to the repairmen, an unfortunate characteristic: it is designed to operate on the same battery used in the missile. Since the life expectancy of this unit is no more than 40 seconds, it's impractical to use it for making tests. Instead, outside batteries are used, which, if the polarity is not correct, can burn out the whole test unit.

Another annoyance is that the guide pin for the test cable connector on the COF is made of soft material that can bend and break when the connecting unit is tightened.

Besides the airborne system and the test set there is a guided missile flight control simulator—the DX43—used for training, that the repairmen must learn to maintain. This system weighs 190 pounds, gives a three-dimensional illusion and can be used indoors. All three items are made by the Nord Aviation Co. of France. The missile system costs \$24,500, the tester, \$8,000, and the trainer, \$23,155.

III. Machine gun and rocket

The XM16 system used on the UH-1B helicopter is a combination of four 7.62-mm machine guns—two on each side of the aircraft—and two 7-tube, 2.75-inch rocket launchers—one on either side. All these weapons are handled by one fire-control system.

The machine guns are fired electrically from the sighting station in the cockpit through a solenoid

IF THERE IS MORE THAN ONE VOLTAGE LEVEL

**YOU
NEED**

VOLTROL® STABILIZERS WITH EI LAMINATIONS

Where multiple output voltage levels are required the importance of lamination design in stabilizing the voltage outputs in constant voltage transformers should be a critical factor in specifying a voltage stabilizing system.

With thin gauge EI laminations the magnetic core of a voltage stabilizer can be adjusted during construction to compensate for variation in electrical parameters. The addition or removal of one or more EI laminations to or from the core stack, while the unit is under construction, can correct minor voltage differences. This then permits that the output voltage can be set precisely to a specified nominal value.

When the proper functioning of electronic equipment is dependent upon the stabilization AND VALUE of the voltage supply, then Voltrol Stabilizers built with EI laminations and precisely adjusted to specified voltages are the solution to this problem.

Voltrol® is a trademark of Acme Electric

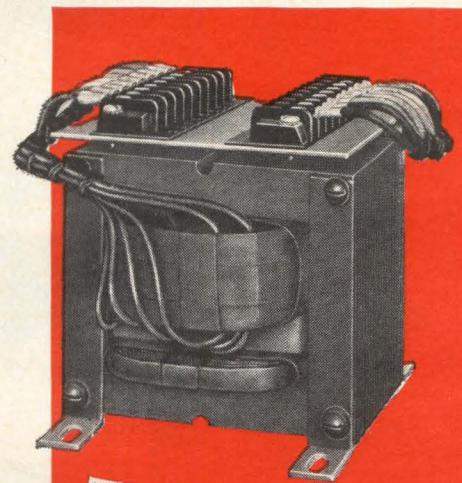

Write for a copy of Bulletin 09 and an "Electro-Technology" reprint covering "Transformer Lamination Design for Constant Voltage Stabilizers".

SAA-4012-3288

Acme Electric

Engineers and Builders of...

311 WATER STREET CUBA, NEW YORK

REGULATED POWER SUPPLIES
STATIC POWER RECTIFIERS
VOLTAGE STABILIZERS
VOLTAGE REGULATORS

"All right, Jeff, we'll buy your system, but you'll have to specify a more advanced X/Y recorder. We need greater versatility and more reliable operation on the job. Any ideas?"



"If you like, Craig, I'll give you the system with the latest X/Y recorder on the market: The PLOTAMATIC® built by Bolt Beranek and Newman's Data Equipment Division. Other users swear by them. The PLOTAMATIC has a paper hold-down system that always works, never gets dirty, and yet allows you to adjust the paper for proper alignment after it's mounted. Input resistance is greater than one megohm, independent of gain setting. Accuracy and input versatility are as good as anything on the market,

and you don't have to buy time base if you don't want it. No high voltages to produce RFI problems, either. Just between us, Craig, I think our people are in a rut with those X/Y recorders we've been using. They use them out of habit, and aren't up on the latest the market has to offer."

BBN's PLOTAMATIC line includes a variety of 8½" x 11" and 11" x 17" X/Y recorders for virtually every application. Keep up with the market—write us for a catalog.



BOLT BERANEK AND NEWMAN INC
DATA EQUIPMENT DIVISION
2126 SOUTH LYON ST., SANTA ANA, CALIF. 92705 (714) 546-5300

on the guns. The rockets are also fired electrically through the intervalometer control panel located on the cockpit console.

The command potentiometers in the machine gun sighting station produce electrical signals as the sight is moved in elevation and deflection. These signals are amplified in the control box and applied to the servomechanisms located in their pylon.

The potentiometers present problems, however. They are built into the pylon in such a way that repairmen can't see them during adjustment—an operation that is frequently required. Nor are the units built to hold up under repeated adjustments. What's needed, the repairmen say, is a better potentiometer in a more accessible place.

Adjustment is also difficult on the heart of the system—the amplifier card in the control box. These cards receive the signals from the sighting station, amplifying and applying them to the servomechanisms in the pylons.

Ticklish job. The potentiometers in the control box which supply electrical signals when the sighting station is not being used are also hard to adjust because they're overly sensitive. When a jeweler's screwdriver is applied to the adjustment screw the potentiometer appears normal, but when the tool is removed, the pot goes off again. The effect is similar to that of one's hands on tv reception when a set's rabbit ears are being moved.

The firing selector switch in the intervalometer used to switch from machine guns to rockets is too delicate, repairmen say, and often burns up. When this happens rockets can't be fired.

The control box power supply isn't stable, repairmen note. The voltage fluctuates, throwing the weapons system out of calibration. A stable power supply is needed plus a test jack on the control box to monitor the power supply. The repairmen would also like a visual indication to facilitate the adjusting of the power supply easier.

The cyclic stick used to fire the weapons should be standardized, one of the instructors says. "Now, every armament system uses a different kind with the firing button in an unexpected place," he asserts.

A request for equipment that can

be "repaired in the field" is also heard for the M6 test set used on the XM16 system. If the men had schematics to guide them they believe they could handle the job.

The XM16 is manufactured by the Emerson Electric Co., the Nortronics division of the Northrup Corp., and the Chromcraft Corp. The system costs \$14,500; the test gear, about \$2,225.

IV. Miniguns and rockets

A system almost identical to the machine-gun rocket combination is the XM21 minigun-rocket system. The XM21 consists of two 7.62-mm miniguns—one on either side of the aircraft—and two 7-tube 2.75-inch rocket launchers—one on either side. The fire-control system is the same as is used for the XM16. It has, of course, the same problems. The XM21 is also used in the UH-1B. A variation is the XM3 system which has the 2.75-inch rocket launcher but neither machine guns nor miniguns.

Three design changes, the repairmen say, could make the XM21 a better system. One simple fault that causes a lot of trouble is the softness of pins in the cable adapter that plugs into the ignition box. They often bend or break off when the plug is being connected. The rigidity of the cable is partially responsible for this, since it makes connecting the plug an awkward task.

Another annoyance is the lead-in wire to the ignitor head in the rocket tube. It isn't sufficiently resistant to heat. After a few firings the insulation breaks down, parting the wire. This results in a short which prevents further firing from the affected tube.

Carbon buildup on the igniter head on the igniter arm assembly of the rocket tube causes lots of headaches and extra work. Carbon from the rocket fire effectively insulates the contact disk of the rocket through which the ignition voltage is supposed to pass to start the rocket motor. The result is that the rocket won't fire. To play safe, the igniter heads—all 48 of them—have to be cleaned after every mission. Contractors for the XM21 are the Emerson Electric Co., Chicago Aerial Industries Inc. and the Chromcraft Corp. Total cost for the system is about \$30,000.

"Welsh, have you heard of the new "GRAFACON" for digitizing graphic data? I hear all you do is trace with a pen and the system digitizes at rates up to 40 inches per second. Know anything about it?"

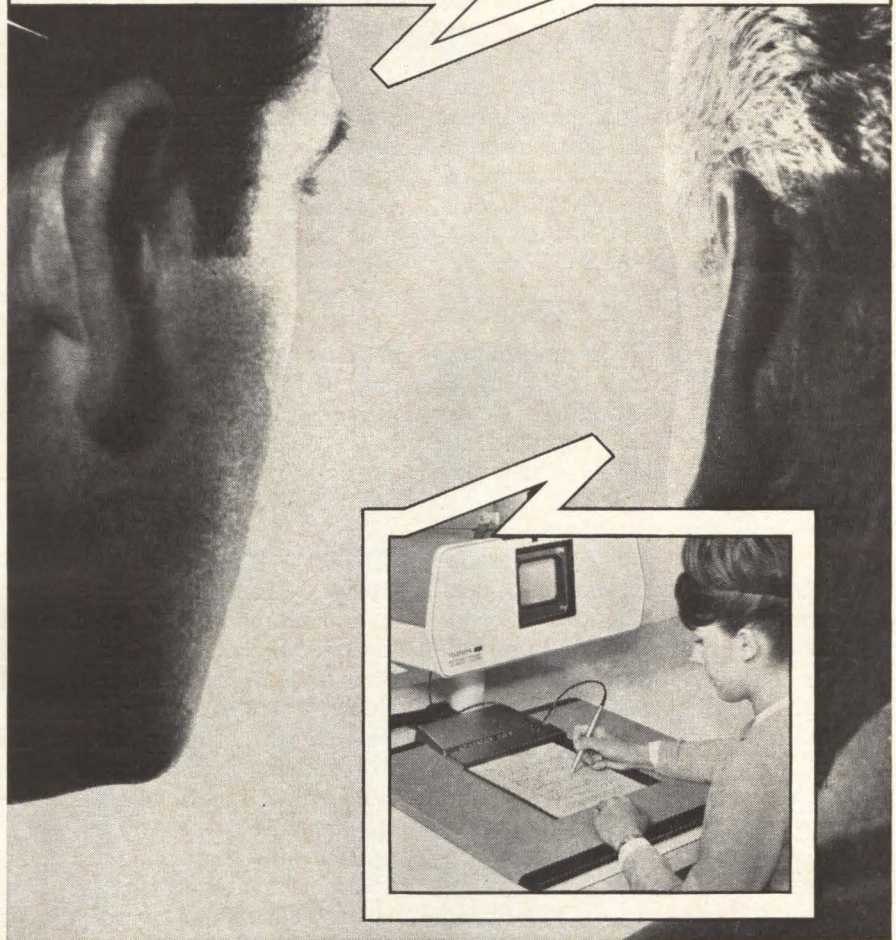

"I saw one of those systems last month, Bryant, and it was a real whiz. They were using it at the time to digitize handwriting, but I understand it'll handle anything from oscillograph records to fingerprints. GRAFACON systems are based upon the "RAND Tablet," a device for directly encoding position information without any encumbering cursors and cross-hairs. No servo-systems, shaft encoders or A/D converters are used. The system encodes the position of a hand-held stylus anywhere on a 10" x 10" working surface, even through several thicknesses of paper. It's set up for rear projection of film data, too, and produces 10 bits of X and 10 bits of Y information once every 220 microseconds."

Off-line GRAFACON systems are available for producing digital records of graphic and pictorial data on punched-paper and digital magnetic tape, and on punched cards. The GRAFACON can also be connected on-line to IBM System/360 machines and to most other computers. Write us for complete details.



BOLT BERANEK AND NEWMAN INC
DATA EQUIPMENT DIVISION

2126 SOUTH LYON ST., SANTA ANA, CALIF. 92705 (714) 546-5300

GRAFACON is built under license from Rand Corporation.

Price slashes wound semiconductor makers

Industry's production capacity still outpaces its marketing finesse; diodes and transistors are among the devices available at bargain rates

Undeclared price warfare has broken out again along a number of fronts in the field of discrete semiconductor devices. Manufacturers are offering unsolicited bargains and shortened delivery schedules. Price tags on general-purpose diodes, metal-can and plastic silicon transistors, epoxy zener diodes and nanosecond diodes are among the notable casualties in a struggle stemming from the industry's preoccupation with volume and its skittishness over any hint of inventory imbalance.

Early last year, a spurt in military, industrial and commercial demand gave semiconductor producers four- to -five- month order backlogs. As supplies tightened, some users overordered as a hedge against deliveries. Since mid-autumn, however, the supply situation has loosened up and order backlogs have fallen to two-to-three-month levels. This adjustment has stampeded some semiconductor manufacturers into offering unasked-for price cuts, thus softening the whole market.

The industry's quick-draw pricing policies are largely the result of its faith in volume. The prevalent theory holds that a manufacturer able to produce in quantity can improve his yields and hence his profit margins. Unfortunately, it hasn't worked this way in recent months. Slackened demand has tempted many semiconductor makers to reduce prices rather than cut back on output. These price moves have been instantly followed by competitors.

Gleeful customers. Except to chide wayward competitors, semiconductor companies characteristically see no price cuts, hear no

price cuts and speak no price cuts. But their customers, gleeful at the buyers' market now in full swing, aren't so reticent.

"Diodes are the key area in the price break," says Richard Breck of the Raytheon Co.'s central purchasing office. "The average price for the IN914 in systems buys was 16 cents during 1966. But at year-end, they were going for 10½ cents apiece. In volume, say a million units, you can get them for 7 or 7½ cents each. For 200,000, the cost might be 8½ cents apiece."

I. Overproduction

Harold M. Zimmermann, director of procurement at the Kearfott Products division of General Precision Inc., agrees that drastic cutbacks in semiconductor prices are increasingly a happy fact of life. After having visited or been in touch with almost every important supplier during the past month, he says: "I think semiconductor manufacturers have overextended themselves. They are overproducing, and many have gone to duplication and triplication of each others' products so we have two or more vendors with identical configurations." This, of course, is just fine with Zimmermann because he can make better deals and establish secondary sources of supply.

The director of manufacturing at a West Coast aerospace company buying large lots of semiconductors for airborne systems and ground support equipment sees a clear trend toward a buyers' market. Prices are dropping on many assemblies, he says, and delivery times are improving.

Winston Willmert, purchasing manager for the Honeywell Co.'s

Electronic Data Processing division has observed a generally downward pricing trend during the past two years, and doesn't believe it has yet bottomed out.

Still smarting from the effects of price wars in the 1950's and early 1960's, semiconductor manufacturers are reluctant to discuss price cuts. Their responses to direct questions are generally didactic and nearly identical.

In particular, the industry's Big Three—Fairchild Camera & Instrument Corp., Motorola Inc. and Texas Instruments Incorporated—who compete savagely in the marketplace, present a remarkably united front in their for-the-record statements on pricing.

Donald Valentine, marketing manager at Fairchild's Semiconductor division, denies there have been any significant moves in the pricing of discrete semiconductors. He points to a price list published in December in which "a significant majority of the prices were unchanged." Valentine acknowledges, however, that Fairchild does not publish its quotes on volume orders—precisely the sector of the market where, according to Raytheon's Breck, most of the horse-trading occurs.

Likewise, Richard J. Hanschen, marketing manager of TI's Semiconductor Components division, discerns no fundamental deterioration in the semiconductor price structure. Nor does he believe that the markdowns now in evidence will persist. His optimism is apparently based on figures showing that the average unit price of all discrete components dropped to only 43 cents from 48 cents over the first 10 months of 1966. While

this 12% slide represents a slowing from the 16% decline posted in all 1965, a check of the semiconductor field reveals that really grievous price slashes were made in the waning weeks of 1966.

Sales charts. Hanschen uses curves and other graphic devices to prove that volume enables a semiconductor manufacturer to hack away at prices. Under normal competitive conditions, he says, cuts should be made as quickly as possible. Miscalculation is always a possibility in this game, Hanschen concedes.

Justified reductions have been made during the past year in prices on diodes for computers and silicon small-signal transistors, according to Hanschen. But he insists that the approximately 20% slashes are largely attributable to a switch to plastic encapsulation.

A semiconductor manufacturer must achieve an average annual increase of about 20% in dollar volume in Hanschen's opinion. To reach this goal in the face of the price cutting that has been going on, π has taken to offering its customers extra services—for a price.

II. Industry shakeout

Noting decelerating declines in certain areas, David W. Hickie, manager of product marketing at Motorola's Semiconductor Products division, doesn't expect any significant weakening of price structures. He does not, however, rule out the possibility of a market undercut by "dumping" if an anticipated shakeout of semiconductor manufacturers comes to pass.

Marginal producers have been expected to fold for several years. But Vietnam defense orders, which stretched out the major concerns' delivery schedules across the board, granted fringe outfits a stay of execution. With the giants' backlogs dwindling, this protection no longer exists and a number of the lesser firms may drop out. Before their exit, however, these companies will bring their inventories to market at fire-sale prices. In this event, Hickie says, Motorola will refuse to meet such cuts and will sit out the absorption period.

George Meadows, marketing manager at the Philco-Ford Corp.'s plant in Spring City, Pa., says his firm has been paring prices on sili-

Glass-Epoxy Copper-clad

through TAYLOR'S TOTAL RELIABILITY PLAN:
Raw materials, panels or punched blanks to your reliability requirements. You get what you order from a fully integrated source.

FAST DELIVERY from two fully equipped plants — one at Valley Forge, Pa., the other at La Verne, Calif. Or from warehouses in Chicago, Ill. and other key locations.

... **FULL SIZE SHEETS, CUT-TO-SIZE PANELS or PUNCHED BLANKS** to satisfy fabricating and processing requirements. Ease of fabrication is a plus value in printed circuit production.

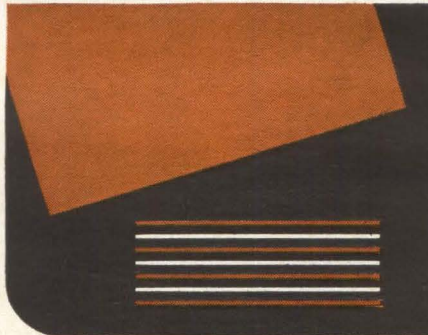
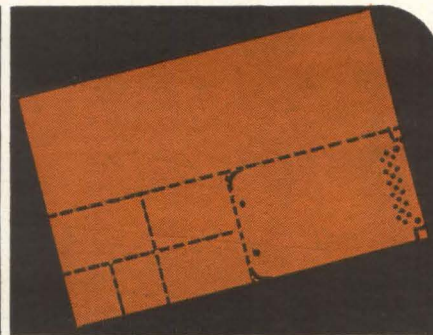
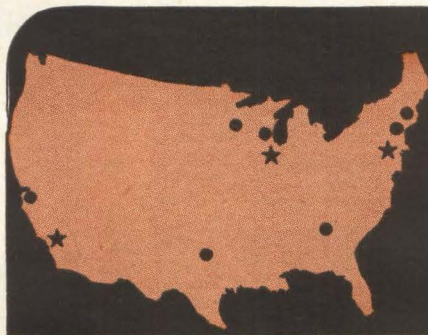

... **STANDARD AND ULTRA-THIN FORMS.** Standard sheets in all grades. Ultra-thin sheets and multilayer preregs in GEC 500 (G-10) and Fireban 600 (G-10, FR-4).

... **WHITE GLOVE HANDLING** in atmosphere-controlled white rooms, careful processing, extremely tight quality control and special packaging assure top performance.

Taylor's copper-clad has proven total reliability demonstrated by an ever increasing number of major OEM's and commercial etchers. This acceptance substantiates our claim for unsurpassed quality, ease of fabrication and delivery to your scheduled requirements. Let us demonstrate this reliability to you. Ask for a sample (give grade designation and copper combination) and a copy of Bulletin GB-2.



Taylor copper-clad

TAYLOR CORPORATION • Valley Forge, Pa. 19481

Phone: 215-666-0300 TWX: 215-666-0659

West Coast Plant: La Verne, Calif.

Also manufacturer of Taylor laminated plastics, Taylorite® vulcanized fibre and Tayloron® preregs

SOLID STATE

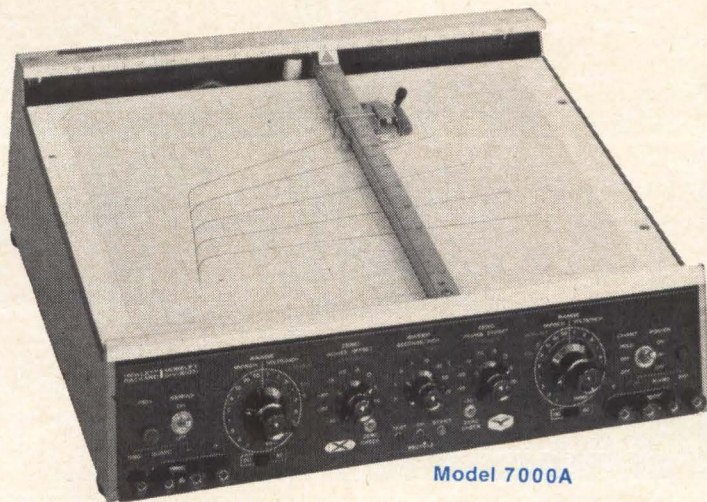

featuring
AUTOGRIP*
electric
holddown

All the advantages of solid-state design and construction are yours in a wide variety of Hewlett-Packard 8½" x 11" and 11" x 17" x-y recorders. Compact, rugged construction; solid-state reliability and long life; all with optional metric calibration and unprecedented performance characteristics. Check the list, then talk to your Hewlett-Packard field engineer about the models most useful for your task. Or write for complete information: Hewlett-Packard, Palo Alto, California 94304, Tel. (415) 326-7000; Europe: 54 Route des Acacias, Geneva.

Data subject to change without notice. Prices f.o.b. factory.

***EXCLUSIVE, CARE-FREE, DEPENDABLE PAPER HOLDDOWN.**

8-1/2" x 11" X-Y RECORDERS

- Bench/rack model in one, portable, 0.5 mv-5 v/in., X-axis time base; Model 135, \$1650.
- 2-pen version of 135, 0.5 mv-50 v/in.; Model 136A, \$2650.
- High-sensitivity model, 1 MΩ input impedance, time base either axis, 0.1 mv-20 v/in.; Model 7030A, \$1895.
- Economy model, 1 mv-10 v/in.; Model 7035A, \$895.

11" x 17" X-Y RECORDERS

- Versatile recorder, X-axis time base, 0.5 mv-50 v/in., high-impedance, computer reference models available; Model 2D Series, from \$1950.
- Economy model of 2D Series, 0.5 mv-10 v/in.; Model 2D-4, \$1490.
- 2-pen version of 2D Series; Model 2FA, \$3375.
- High-sensitivity ac/dc recorder, time base either axis, 0.1 mv-20 v/in. dc, 5 mv-20 v/in. ac; Model 7000A, \$2495 (also available without ac input, Model 7001A \$2175).
- Automatic data plotting system, null detector and character printer built in, 0.5 mv-10 v/in.; Model 7590C, \$1985.

**HEWLETT
PACKARD**  **MOSELEY
DIVISION**

1790

con transistors during the past three to five months to get rid of a large inventory. One reason for the unloading operation is the availability of cheap epoxy transistors from Hong Kong, where Fairchild has a plant, as well as from other Asian countries. These devices are being bought for entertainment equipment and for limited environmental stress assemblies for military ground support systems.

Motorola and Fairchild, the industry's consensus price leaders, are, according to a marketing man for a sizable East Coast semiconductor supplier, "having a field day with each other on the pricing of silicon transistors. They both have plenty on hand so we're watching them closely." While his company isn't planning any cuts, this source admits he is faced with more aggressive pricing.

Nor is the long-term outlook for semiconductor makers particularly sanguine. "As far as list prices are concerned, semiconductors are a strange breed of cat," says Raytheon's Breck. "There's always someone down the street with a lower price." Though he doesn't expect the current pricing spree on diodes to last much longer, the industry has a history of regaining only part of the ground it loses during its periodic slugs. Data compiled by the International Telephone and Telegraph Corp. suggests that while worldwide unit sales of silicon transistors will more than double from current levels by 1971, dollar sales will remain static. This prospect results from the perfection of plastic encapsulation techniques.

In striving to boost volume, semiconductor companies have become victims of their own technical capabilities. "There's always been a buyers' market in semiconductors," says the purchasing agent at an East Coast electronics company. "It's still an immature industry and prices go down as capacity goes up."

A purchasing executive with a Los Angeles aerospace firm goes a step further: "As a result of higher yields and lower packaging costs, it's only a matter of time before a situation akin to the transistor debacle of the 1950's develops. It's inherent in the industry's mechanization."



MINI-L-P
ANTENNA
150 - 1000 MC

DM AR122-1

SIZE OF CONVENTIONAL L-P FOR SAME FREQUENCY RANGE

DM AR122-1
LOG PERIODIC ANTENNA

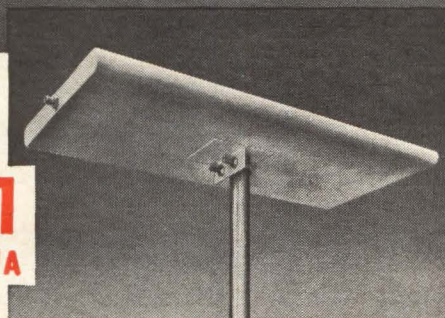

The size of broadband antennas has been radically reduced by Dorne and Margolin, Inc. Without sacrifice of performance, the DM AR122-1 occupies less than a third the area of the conventional L-P.

Rugged, weather-proofed, and light of weight, the antenna shown is available for 30 day delivery. Other models designed for higher or lower frequency bands can be supplied.

Order the DM AR122-1 for surveillance, communication, or other field uses, from either D & M facility.

VSWR 2.2:1
GAIN 6db/iso
IMPEDANCE .. 50Ω
WEIGHT 12 lbs
SIZE 22 5/8 x
37 1/4 x 1 in
PRICE ..

\$435⁰⁰

30 DAY DELIVERY

dorne and margolin

I N C O R P O R A T E D

20 Years of Leadership in Aircraft and Missile Antennas

HEADQUARTERS: 2950 VETERANS MEMORIAL HWY., BOHEMIA, N. Y.
ZIP 11716 • TEL. 516 585-4000 • TWX 510 228-6502

AEROSPACE DIV.: 9730 COZYCROFT AVE., CHATSWORTH, CALIF.
ZIP 91311 • TEL. 213 341-4010 • TWX 213 341-4646

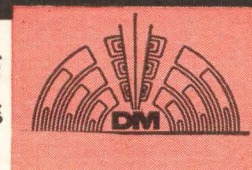

Aerospace skills brought down to earth

Systems engineering is now being employed in mundane new markets, including waste disposal, airport transit and blood bank control

By Walter Barney

San Francisco regional editor

"Three years ago," says Eric L. Peterson, "All I knew about blood was that it was red, it flowed, it was considered good to give, and my sister's was Rh negative." As an employee of the Lockheed Missiles & Space Co. there was small reason for him to know more; yet today, as manager of Lockheed Missiles' expanding blood bank inventory control program, Peterson knows plenty about blood and is indirectly responsible for thousands of pints of it.

A year ago, as assistant chief engineer for the Los Angeles County sanitation district, Frank L. Bowerman was a stranger to systems analysis. Today, as assistant to the vice president for development at the Aerojet-General Corp. he juggles—albeit in gingerly fashion—terms like "trade off" and "conceptual design," and coordinates the work of a staff of systems engineers.

These men personify the trend to what has been described as "the application of aerospace methods to social problems." A better description would be the application of aerospace companies to new markets. Lockheed Missiles & Space Co., a division of the Lockheed Aircraft Corp., and Aerojet both have down-to-earth reasons for entering this earthbound field. Their aims and their approaches, however, differ radically. Lockheed wants to sell services while Aerojet is aiming at hardware business.

I. Hard or soft

Aerojet, a subsidiary of the General Tire & Rubber Co., was one of four companies that made systems studies for the State of California; its specific field of study was solid waste disposal. Currently, the com-

pany is under contract to do a follow-on study for Fresno County. "What interested me in making the change from government to industry," Bowerman says, "was that Aerojet made it clear that its main interest was in developing new hardware. Working for the county, I had been unable to implement many ideas because there was no hardware available."

Lockheed Missiles & Space Co. apparently expects its fledgling information systems organization, now a part of its research and development unit, to become an independent operation selling its services.

Melvin H. Hodge, Lockheed Missiles' assistant to the director of information systems, observes that computers are no longer thought of as individual chunks of

hardware but as parts of large systems. Lockheed figures that software and communications account for two-thirds of the cost of a computer system. It has therefore concentrated its efforts in this part of the market, buying its hardware and providing only special interface components of the system.

The Video Matrix system that it just shipped to the Mayo Clinic, Rochester, Minn., for example, uses a Scientific Data Systems 92 computer, a Univac drum memory, and an International Business Machines Corp. teleprinter. Lockheed's hardware contribution to the system, which employs remote terminals to speed the administration of medication and streamline hospital business procedures, was a light pen.

The company has moved strongly into two markets: hospital services and state and local government information services. "The medical market will be over \$1-billion a year by 1975," Hodge says. "Now it's almost nil. State and local governments spent \$75 billion for goods and services in 1964, passing the Federal Government in that department," he continues. "There are 13 million people working for the government, and half of them are doing paper work. The market is so big I've even quit thinking about it. We could be off in our estimate by a factor of 10 and it wouldn't matter."

Brave words. Thomas C. Rowan, vice president of the nonprofit Systems Development Corp. and manager of its Advanced Systems division, agrees with Hodge about the market potential but is skeptical as to whether a hardware company can crack it.

"When the California studies be-



Thomas C. Rowan of SDC—"Hardware and software are like popcorn and the movies; which brings in the money?"

OHMICONE®
SILICONE-CERAMIC
COATED AXIAL LEAD
RESISTORS

two Choices from OHMITE



1

MOLDED



SERIES 88 • MOLDED OHMICONE®

Coating is uniformly thick, dense and smooth. Meets 1000 VAC insulation test. Consistent form and size make these resistors highly suitable for rapid automated assembly techniques and also permit firm mounting in clips for significant heat-sink advantages. Available in commercial, military, precision, and non-inductive types. Can be provided to meet new Char. U of MIL-R-26. Solderable or weldable leads. (Bulletin 101)

Wattages (Commercial): 1.5, 2.25, 3.25, 6.5, 9, 11 watts at 25°C.

Resistances: 0.1 to 226K ohms.

Tolerances: To 0.05%; standard commercial, 3%.

Low Temperature Coefficient of Resistance: 0 ± 20 ppm/°C, 10 ohms and above.

2

CONFORMAL

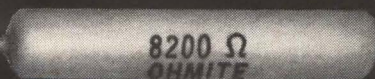

SERIES 44 • CONFORMAL OHMICONE®

Same basic high quality wire-wound resistor as above, but with a conformal coating (1000 VAC rating). While it does not have the uniform shape and dimensions of the molded Series 88, the Series 44 is available with the same close, standard tolerance and low TC. It is supplied in commercial and high precision types. Can also be furnished to meet MIL-R-26 requirements. (Bulletin 109)

Wattages (Commercial): 1.5, 3.25, 6.5, 11 watts at 25°C.

Resistances: 0.1 to 442K ohms.

Tolerances: To 0.05%; commercial, 3% for values above 1 ohm.

Low Temperature Coefficient of Resistance: Standard is 0 ± 20 ppm/°C for 10 ohms or more.

OHMICONE Silicone-Ceramic—Not just a conventional silicone coating, but rather silicone combined with a ceramic compound. Blending the two materials provides a coating which has the best characteristics of each. Developed and patented by Ohmite, *Ohmicone* envelopes a wire-wound resistor in an unusually tough, resilient jacket that has high moisture resistance and excellent dielectric properties, plus good stability and low temperature coefficients. Choose either the molded or conformal coating in accordance with your requirements.

**RHEOSTATS • POWER RESISTORS • PRECISION RESISTORS • VARIABLE TRANSFORMERS • RELAYS
TAP SWITCHES • TANTALUM CAPACITORS • SEMICONDUCTOR CONTROLS • R.F. CHOKES**

OHMITE

MANUFACTURING COMPANY

3610 Howard Street • Skokie, Illinois 60076

Phone: (312) ORchard 5-2600



Direct answers . . .

Bausch & Lomb V.O.M. Recorders give just that. Without external converters, they will *directly* measure and record d-c voltage, current and resistance. They provide performance you can depend on with their multiple inputs, fast pen response, photoelectric chopper, high off-balance impedance, built-in paper take-up reel or instant reference tear-off.

V.O.M. Recorders come equipped with features that are usually sold as optional extras—five variable chart

speeds, an event marker, a zener stabilized reference supply, three-position operation and a full scale zero set. Low cost V.O.M. Recorders offer extra versatility at no extra cost.

Bausch & Lomb V.O.M. Recorders are available in a variety of models with different full scale sensitivity. A wide range of accessories further extend their usefulness. Customized models can be built to handle special applications. Write for Catalog 37-2194. Or, if you prefer, let us show you how to get direct answers with a personal demonstration. Bausch & Lomb, 61437 Bausch Street, Rochester, New York 14602.

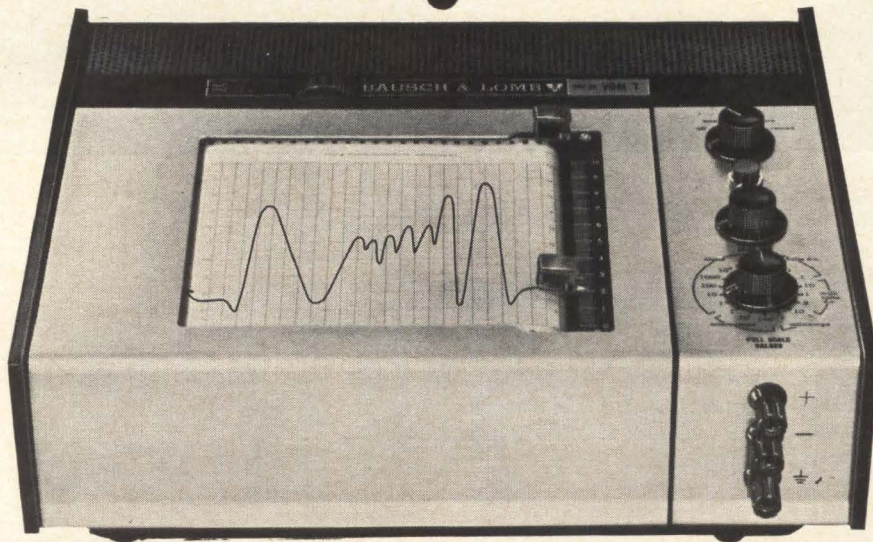

BAUSCH & LOMB 
ELECTRONICS DIVISION

In Canada, Bausch & Lomb Optical Co., Ltd., 16 Grosvenor St., Toronto, Ontario.

gan," he says, "they were not considered as part of a market that looked better than the lush military market, but as a diversification measure against a military cut-back. Now that the Vietnam effort has escalated, some top management support has evaporated—and some of the field's top project managers are just being tolerated."

It's a question, Rowan explains, of return on investment. The big difficulty in the studies for California was in integrating systems techniques with knowledge of the field under study. Rowan concedes the hospital and government markets look good—SDC itself is carrying out several government studies—but not for an aerospace company unless there is hardware in sight.

II. Banking for profit

Lockheed Missiles commitment to information management, however, seems solid. In addition to its study of California's information-handling problems, it has undertaken a study of that state's occupational licensing system and of Alaska's information processing. It is also computerizing an information system in educational research for the Far West Laboratory for Educational Research and Development, and has contracts for



Melvin H. Hodge of Lockheed—"The market is so big I've even quit thinking about it. We could be off in our estimate by a factor of 10 and it wouldn't matter."

clinical and administrative data processing for hospitals in Saskatchewan, the San Francisco Bay area and Texas. Further, its original program for the Alameda-Contra Costa County blood bank, across the bay from San Francisco, is being applied to blood banks in Los Angeles and Sacramento.

The Alameda-Contra Costa operation, Lockheed Missiles first venture into blood banking, provides a good, if microcosmic, example of the company's approach. The first step, in June of 1964, was a joint study to acquaint Lockheed with the needs of the bank, and the bank with the methods of data processing. Peterson found that a blood bank must know where its blood actually is (there are 30 hospitals in the system, with some blood stored at each), how old it is, and whether or not it is on cross match—that is, reserved for a particular patient.

If a blood bank could stock blood the way Fort Knox stacks gold bars, there would be no need for an elaborate inventory control system. But whole blood is only good for 21 days, after which it must be used for plasma or thrown away. After a certain point, a large inventory is wasteful; but too small an inventory could cost lives.

After determining the desired output format and working out samples, Lockheed made a five-day dry run. "Three of us worked 18 hours a day on the simulation," Peterson says. "We took real input data and processed it by punched card and by hand." Peterson was then ready to write a program. He chose Neliac, an advanced scientific language, rather than the business-oriented Cobol, because more information can be put into a Neliac word.

Shift to speed. The program was run on an IBM 7094 computer, and Lockheed found that an entire day's inventory changes could be executed in about 50 seconds of computer time. To handle certain difficulties encountered in using Neliac and to increase speed even further, the program is now being shifted to a Univac 1108, which has 65,534 words of core memory. With all data stored in the core, execution time will be about 20 seconds.

The computer time is important—and not only because of the ex-



Frank L. Bowerman of Aerojet.
"Aerospace companies evaluate all aspects of the problem."

pense. Blood banking, like hotel accounting, turns out to be a nighttime operation at Lockheed. Hospitals phone information on changes in their blood stocks to the bank at the end of each day; this information is punched on a Friden Inc. Flexowriter and transmitted by Dataphone to the Lockheed plant in Sunnyvale, Calif. Next morning, the blood bank gets its daily report on how much blood is on hand and what its status is. The data includes identification numbers, quantity, location, age, source, cross-match status and types of blood.

The potential market for this sort of system, Peterson figures, is about 250 blood banks. The Los Angeles bank alone, which serves 222 hospitals and handles 200,000 pints of blood a year, will require about three minutes of computer time. If Lockheed were to sign up every bank—and that seems to be its goal—the 1108 would be busy for four to five hours a night doing nothing but shuffling data on blood.

Once the program had been developed, Lockheed and the bank signed a contract under which Alameda-Contra Costa paid 95 cents for each pint of blood recorded in the computer memory. The first year's work was very much a developmental effort; Lockheed figures it had a loss of \$1.80 per pint (the bank handles about 33,000 pints a year). "Back in January of 1965," Peterson recalls, "I was getting up at 4:30 every morning so that I could drive to Oakland and hold peoples' hands all day."

Forging ahead. Results, though, have been spectacular. Inventory

Want to design for
INSTANT STARTING?...
SPLIT-SECOND ACCURACY?
REVERSIBILITY?...
MIXED SPEEDS?...

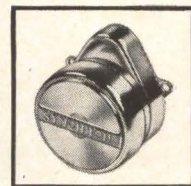
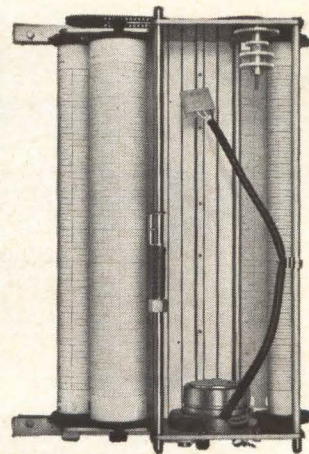

turn the
job over to
SYNCHRON® MOTORS!

No matter whether you want a motor to withstand swiftly changing temperatures, meet fast-reversing stresses, turn a small part with exact accuracy to 1 Rev. per week or 600 Rev. per minute, there's a SYNCHRON Motor that can do it! It can do a hundred other things as demanding as these — if you tell us how you want it to function. Before you start any design that calls for small drive or timing motors, think of SYNCHRON Motors, and call or write us at Hansen Manufacturing Company. We'll be there at once to help — with experience. Better still — don't wait till you face a problem. Write us now — let us tell you about SYNCHRON Motors and the ways we design them to work for you.



HANSEN REPRESENTATIVES: CAREY & ASSOCIATES, Houston, Tex., R. S. HOPKINS CO., Sherman Oaks, Calif., MELCHIOR & MACPHERSON, INC., San Carlos, Calif., THE FROMM CO., Elmwood Park, Ill., H. C. JOHNSON AGENCY, INC., Rochester, N. Y., WILSON ELECTRIC CO., Essex, Conn., Norberth, Pa., and New York, N. Y. EXPORT DEPARTMENT, 64-14 Woodside Ave., Woodside, N. Y.

TRW

MINUTEMAN

INVERTERS

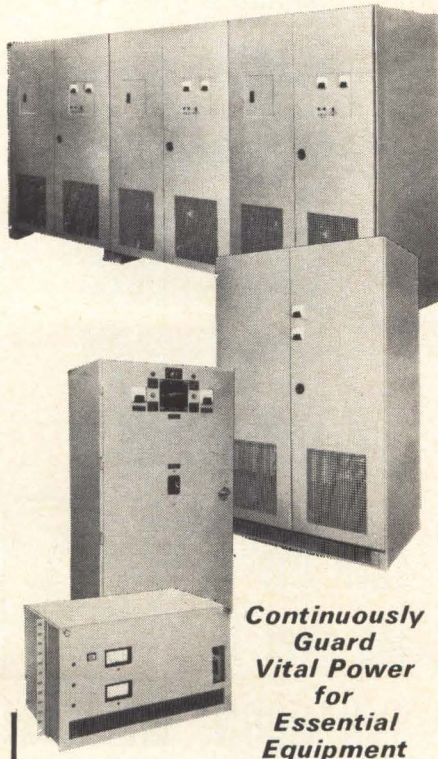

**Continuously
Guard
Vital Power
for
Essential
Equipment**

TRW Minuteman Inverter Systems include a broad range of models and equipment options from 100 VA to 100 KVA — single phase and three phase, with a variety of operational modes — including redundant and standby arrangements.

Guarding the continuous flow of power for communications equipment, process instrumentation, computers and other critical loads is the full time occupation of these Minutemen.

Other Minuteman Products

DC to DC Converters:
100 W to 20 KW.

Solid State AC Bus Transfer Switches:
from 25 amperes to 200 amperes.

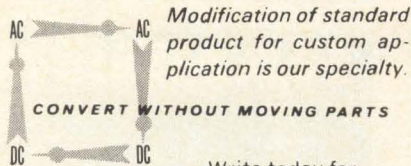

Write today for
complete information.

**TRW EQUIPMENT
OPERATIONS**
Dept. 0855
23555 Euclid Avenue
Cleveland, Ohio 44117

has been reduced from between 1,000 and 1,100 pints to 800 or 850, a cut of more than 20%. Also, the percentage of outdated blood has gone from over 13% to below 3%; the national average is 15%. Peterson thinks that 2½% to 3% is about as good as one can hope for.

Moreover, the bank now has a much better accounting of the flow of blood, and can judge how much blood it should keep on hand. If Alameda Hospital, for instance, has averaged 10 pints transfused per week, the bank can very reasonably turn down a pathologist who wants to keep 35 to 40 pints in the refrigerator.

There were, of course, some difficulties. At first, for instance, hospitals had a tendency to falsely report blood as being on cross match in order to prevent its return to the bank. They didn't believe the figures.

Lockheed itself has run into trouble in trying to write a basic program applicable to all banks. Some banks want a daily report on how much blood is within five days of being outdated, while others want that figure for six or seven days.

The blood bank program makes money now, even though the cost to the bank has been reduced to 45 cents a pint. Lockheed had certainly taken a systems approach to the blood bank's problem, and once it solved that problem, it kept on selling a service.

III. Another approach

The Aerojet approach to waste disposal is different. Bowerman has suggested two types of hardware that don't currently exist—a container for dumping refuse in the sea (so it won't float to the surface), and a pneumatic refuse-collection system for several apartment houses—an analog to a sewer.

Touches all bases. Aerojet's contract with Fresno County calls for a review of solid-waste disposal with respect to public health in all of its aspects: odor, fire hazards, flies, disease, even aesthetics. If the company were later to get a hardware contract, it would build a system and then, presumably, go hunting for another customer.

In this study, as in almost all projects for governmental agencies, the systems approach has run

head-on into political realities. But Bowerman is familiar with this sort of difficulty from his days with the sanitation district, when differences in city garbage collection techniques frustrated efforts to control the fly cycle; and he is absolutely sold on systems analysis.

"Aerospace companies evaluate all aspects of a problem—even when the proposal was due yesterday," he says.

IV. Hand in hand

"Hardware and software," muses sdc's Rowan, "are like popcorn and the movies; which brings in the money? In general, we've just seen the beginning of this trend to systems solutions for social problems. As state and local governments see the potential in computers and automation in general, they'll have to buy it.

"The expense of course, will shock them" he says. Waste disposal, for instance, is a Department of Defense order-of-magnitude problem. But local agencies are already bearing the costs; the systems approach merely brings such outlays to the surface.

"I do think," Rowan continues, "that the 'aerospace' idea has been oversold. What aerospace people really bring is management. The universities don't have the interdisciplinary approach. Typically, people from different disciplines study the same problem as it relates to their own areas. We can tie in the social sciences, computers and engineers in the same way we related electronics, life sciences, propulsion, aeronautics and so forth in space."

Sdc has some 60 studies currently in the works, and Rowan says that sheer volume may be one answer to the problem of profits for hardware companies, since only with high volume can they afford to maintain large professional staffs. He cites the Skylounge project, in which sdc is overseeing five other companies in a study of a novel method of getting plane passengers from city to airport, as a good example of the company's methods.

Skylounge, basically, is a system by which a ground vehicle built by the Budd Corp. would collect passengers at several downtown stops and would then be mated to a heli-

FUSEHOLDERS FOR BUSS FUSES

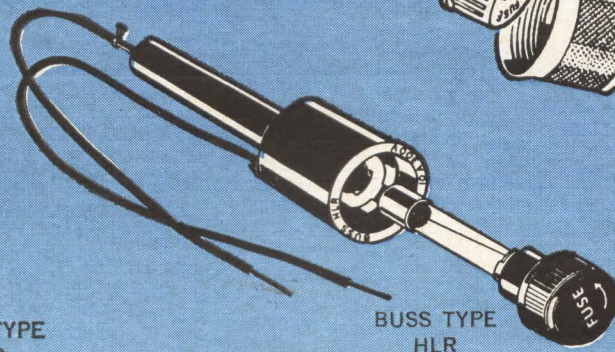
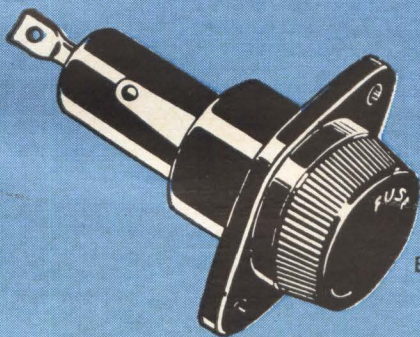
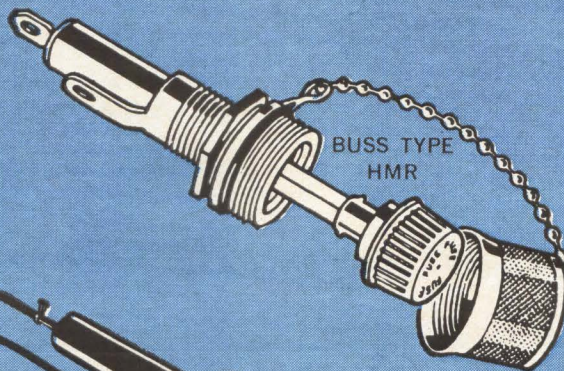
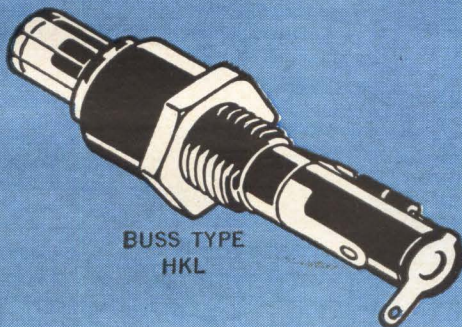
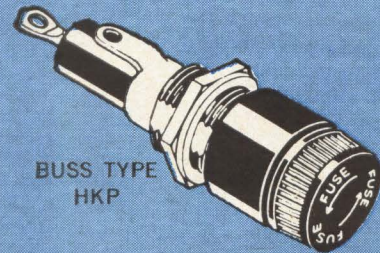
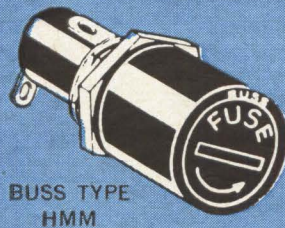
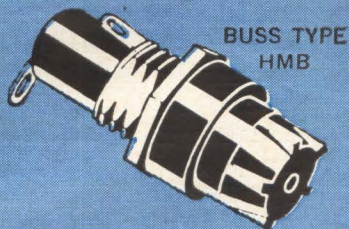

Panel mounted, in-the-line, lamp indicating, signal activating, visual indicating fuseholders—with solder terminals, quick-connect terminals or special terminals—for fuses from $\frac{1}{4} \times \frac{5}{8}$ inches and larger.

Fuseholders of various types to meet Commercial and Military specifications.

For full information on the many small dimension fuse mountings and companion fuses available from BUSS... write for BUSS Bulletin SFB.

BE PROFIT WISE... INSIST ON BUSS QUALITY

SUPPLIED THE ECONOMICAL WAY—THRU ELECTRONIC DISTRIBUTORS

BUSSMANN MFG. DIV. McGraw Edison Co. St. Louis, Mo. 63107



FOR SUPERFINE
CUTTING OF
HARD, BRITTLE
MATERIALS...

THE S. S. WHITE AIRBRASIVE® UNIT

Airbrasive technicians get carried away with their demonstrations sometimes... there's nothing safe from a tool that cuts just about anything hard and brittle.

What does it prove? The Airbrasive is a unique tool of a thousand uses in shop or laboratory. A precise stream of gas-propelled particles (cuts as fine as 0.005") made it possible for us to cut this TV tube like a radish. The Airbrasive has a cool completely shockless cutting action, which can be applied to such hard-to-work materials as germanium, tungsten, glass, ferrites, and ceramics. It will clean, cut, abrade, remove surface coatings, adjust microminiature circuits, strip potentiometers, debur tiny parts, and perform many more delicate tasks.

In many cases you will find that the Airbrasive pays for itself on the first application by eliminating rejects, reducing handwork, or simply performing a job that you had previously thought impossible. For under \$1000 you can set up your own Airbrasive cutting unit.

You don't believe in magic wands?... just try us. Send samples of your impossible jobs... and we'll test them free of charge.

SEND FOR BULLETIN 6407A—Complete Information



S. S. WHITE, COMPANY, INDUSTRIAL DIVISION, Dept. EU,
201 East 42nd Street, N.Y., N.Y. 10017, Telephone 212 661-3320



S.S. WHITE®

1342A

copter similar to the S-64 Skycrane, developed by Sikorsky Aircraft, for its flight to the airport. Once there, the helicopter would disengage and the bus would make the rounds of the terminals.

In the lion's mouth. The study is being made in Los Angeles, where transportation problems are so bad that the police broadcast a traffic alert one Sunday last fall, warning motorists not to go to the airport because of the jam-up. But the survey is intended to have general implications for other cities.

SDC is coordinating the work of Budd, AirporTransit, Los Angeles Airways and Sikorsky, a division of the United Aircraft Corp. Los Angeles Airways currently runs a subsidized helicopter service to the airport, while AirporTransit provides bus service. An architectural firm, William L. Pereira & Associates, is also involved in the project.

The fact that the ground vehicle must be flown, says project manager Fred Zimmerman, has led to a bewildering number of trade-offs and mutually conflicting requirements. The vehicle must conform to regulations laid down by both the Federal Aviation Agency and the California Department of Motor Vehicles, for instance. The dimensions and weight of the vehicle, the number and size of the exits, the volume of the baggage compartment, and the communications system must be integrated with ground and air regulations, the nature of the helicopter, the optimum payload and the method of transferring passengers to planes.

In addition, Zimmerman notes, there are no precedents for ticketing, baggage handling or allocation of fares. He is thinking—perhaps dreaming—of one day being able to buy a ticket from, say, Van Nuys, California, to Scarsdale, N.Y.

The Skylounge project is perhaps a more traditional application of the system method, which itself seems to be undergoing some changes as it is applied to new problems. But both Lockheed Missile and Aerojet—and the other California aerospace companies—are backing their approaches with money and personnel. And even when the ballyhoo is discounted, their methods seem to be winning acceptance.

Jungle fighters on Chesapeake Bay

The staff of the Army's Limited War Laboratory in Maryland is developing special gear to combat guerrillas. Today's prototypes are tomorrow's hardware, much of it electronic

By John F. Mason

Military electronics editor

A Vietcong rifleman takes aim at a U.S. helicopter as it clears a hill a mile away. When it's within range he fires. No hit. He aims again, but the craft cuts sharply to its right, beginning evasive action. Acoustic sensors fixed to the bottom of the helicopter have warned the pilot of that initial shot despite the noise of his engine and rotors. The warning system, developed at a laboratory at Aberdeen Proving Ground, Md., has perhaps saved the craft.

The campus-like setting of the Army's Limited War Laboratory belies the facility's deadly serious mission of furnishing special weapons and equipment to combat guerrillas in underdeveloped areas of the world. Products of this building on the shores of Chesapeake Bay get their final test in the rice paddies of Vietnam.

Some 100 projects, 23 of them involving electronics, are currently being worked on at the lab, which is under the command of the Special Warfare division of the Office of the Army's Chief of Research and Development.

Col. Robert W. McEvoy, the lab's commanding officer, and his 11-man officer corps have all spent time in Southeast Asia, as have many of the 65 civilian engineers, physicists and researchers on the staff. And at least one civilian or military representative from the lab is always posted in Vietnam. These men constantly observe operations and interview servicemen to come up with ideas for improv-

ing battlefield performance. They send memos, sketches and suggestions back to Aberdeen for possible action.

In addition, battle commanders as well as R&D agencies in Vietnam and Thailand can submit formal proposals through channels. Finally, staff members are free to

pursue their own technological bent: anyone at the lab with an idea can get \$2,000 and 90 days to develop it.

Before work continues on a project at Aberdeen, the proposal must be reviewed and approved by a board. Those that are approved are expected to result in hardware



Circular pod of acoustic sensors fixed to the bottom of a helicopter picks up sonic boom of projectiles to warn pilot of small-arms attack

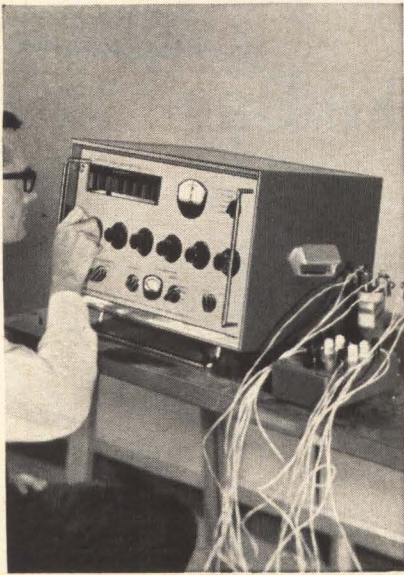

Rosemount precision resistance ratio bridge disregards lead resistance and thermal emf's

Rosemount's VLF 51 Precision Resistance Ratio Bridge measures resistance ratios with exceptional accuracy, stability and speed. It disregards **both** lead resistances and thermal emf's, which can disrupt conventional dc resistance measurements. Leads hundreds of yards long and varying from one to another in resistance will not seriously degrade the accuracy. Thermal emf's from bi-metal connections and ambient variations have no effect on accuracy.

The digital ratio readout is accurate to 10 ppm at ratios near 1.0 in the range of 0.1 to 500 ohms. This is achieved by employing current transformers and a unique scheme of modulation and demodulation.

Full specifications and operating data are available from Rosemount.

SPECIFICATIONS

Accuracy ± 10 ppm to ± 400 ppm
 Resolution 1 in 10^4
 Resistance Range
 Full accuracy 0.1-500 ohms
 Reduced accuracy 10^{-3} to 10^4 ohms



4900 West 78th Street
 Minneapolis, Minnesota 55435

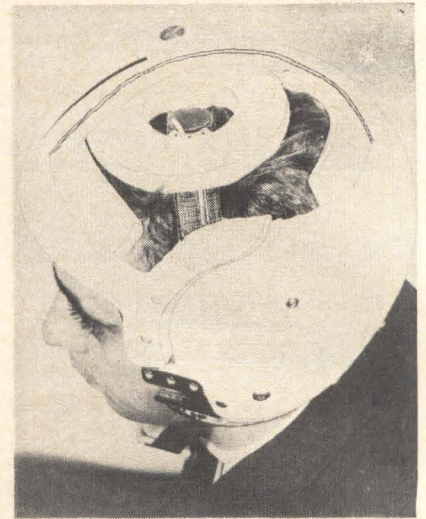
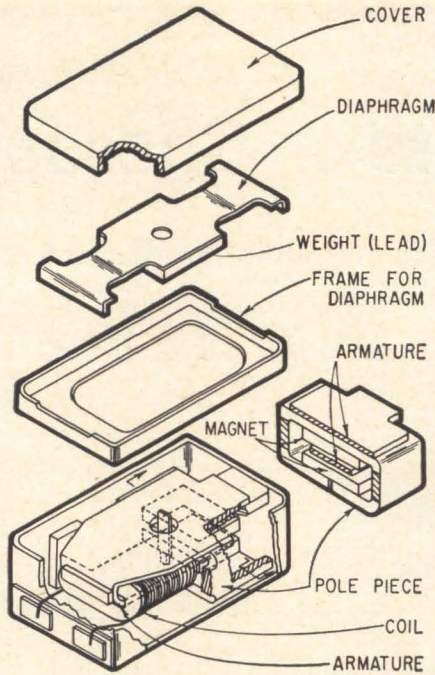

Experimental microphone built into top of helicopter crewman's helmet enables him to talk without interference from wind noise and to keep both hands free.

within 18 to 24 months. Prototype equipment, supplied by the lab or outside contractors, is subjected to rigorous field tests by troops at Aberdeen before being shipped to Vietnam. If the prototype proves useful in combat, it is put into service by the Army.

I. Helping helicopters

One such development is the acoustic bullet-detector for helicopters. All too often, pilots don't know when they are under small-arms attack because engine noise drowns out the sound of the shots. To carry pilots and their craft through these vulnerable periods, a device is being tested that picks up the sound of enemy projectiles as they pass the aircraft. The detector listens for frequencies rather than sound volume, reacting to the higher frequencies of the sonic boom but ignoring the low-frequency noise of the engine. The device also detects and "points toward" the muzzle blast of the enemy weapon, displaying the azimuth and angle of depression—below the horizon—on a cathode-ray-tube display.

A pod of acoustic sensors, or microphones, is fixed to the bottom of the helicopter, while inside the craft are a computer, amplifiers, filters, display-driving circuits and the pilot's display.

An earlier model of the device was field-tested in Vietnam last April. The current version will go

to Vietnam this spring. Meanwhile, various other kinds of sensors will be checked for accuracy, range and applications on other kinds of aircraft.

II. Talking through your hat

Another of the lab's efforts undergoing tests in Vietnam with the 1st Cavalry Division (Airmobile) is a microphone built into the top of a helicopter crewman's helmet that enables him to talk through his skull. Wind noise picked up by a conventional mouth microphone when a door gunner leans out of the windowless helicopter often makes communication with the pilot impossible. Throat mikes aren't popular in Vietnam because they are hot and tight and require a free hand to operate.

The new bone-conduction microphone is held in place by a chamois pad resting on the roof of the cranium. Voice vibrations pass through the liquid in the brain and through the skull into the microphone. A full head of hair blocks surprisingly little sound—no more than 1 decibel. Satisfactory performances in 100-knot winds with ambient noise levels up to 130 decibels have been achieved with the mike.

The rectangular variable-reluctance transducer measures .44 by .22 by .16 inch and weighs .94 gram. A magnetic translating portion at the bottom of the unit has a pole piece, a pair of magnets, a

Thrifty HF antenna. Skimps on acreage.

One powerful 3½-acre log-periodic can replace up to 14 acres of rhombic arrays.

Land-saving is just one advantage. Consider the performance: It puts the energy where you need it. From 2.5 to 32MHz, it provides constant patterns, low VSWR (2.0:1), low side lobes (-14 db), and high efficiency (better than 90%). Do you need compact quality *and* economy? G/A has the answer now: the world's largest HF antenna selection. Request full data.

1601 California Ave., Palo Alto, California / Russell House, Molesey Rd., Walton-on-Thames, Surrey, England / 35 Ben Boyd Rd., Neutral Bay, Sydney, NSW, Australia



Granger

Associates



Cramped for space?

Use Couch 1/7-size Relays

Space/weight problem? The new Couch 2X 1/7-size crystal can relay gives you tremendous savings in space and weight. 0.1" grid — plus many outstanding specs — *all in micro-miniature*. Thoroughly field-proven in electronics and space applications.

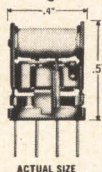

	2X (DPDT)	1X (SPDT)
Size	0.2" x 0.4" x 0.5"	same
Contacts	0.5 amp @ 30 VDC	same
Coil Operating Power	100 mw 150 mw	70 mw 100 mw
Coil Resistance	60 to 4000 ohms	125 to 4000 ohms
Temperature	-65°C to 125°C	same
Vibration	20 G	same
Shock	75 G	same

Broad choice of terminals, coil resistances, mounting styles. Write for detailed data sheets.

RUGGED ROTARY RELAYS  Dynamically and Statically Balanced

COUCH ORDNANCE INC.

3 Arlington St., North Quincy, Mass. 02171, Area Code 617, CYPress 8-4147 • A subsidiary of S. H. COUCH COMPANY, INC.

folder armature and a coil interlocking the armature, to which a drive rod is attached. The transducer's shell is made of a 45%-to-50% nickel alloy and the center structure of an 80% nickel alloy. A reed inside the device moves when the operator speaks, remaining at rest when there is no sound. Mike-equipped helmets have a solid state amplifier powered by a single mercury cell. The battery is good for 30 days of continuous use.

The Navy and Marine Corps are testing the device, and a number of civilian agencies, including the Los Angeles motorcycle police, are interested. The developer, Dyna Magnetics Devices Inc. of Hicksville, N.Y., says it has received more than 200 inquiries about the mike from private detective agencies.

III. Electroluminescence

Another lab project being tested in Vietnam is a lightweight, portable, electroluminescent lighting system for use at airfields in remote areas. The system was developed by Sylvania Electric Products Inc., a subsidiary of the General Telephone & Electronics Corp.

Sylvania's flexible electroluminescent tapelight is the basis of this system. It consists of electrically activated phosphors laminated between two electrically conductive plates, one of them aluminum, the other translucent plastic. When a-c voltage is applied, the phosphors are activated, producing light. The material comes in strips 1.75 inches wide and in lengths up to 150 feet.

Light from the device is visible at an altitude of 2,000 feet and a slant range of three miles. The system was designed to mark runways, heliports or drop zones for approaches, landings or take-offs in the dark, but it has found such homely applications in Vietnam as illuminating latrines. When tilted slightly upward, the lights aren't bright enough to alert the Vietcong, but they are sufficient to guide a *cr* to the appropriate field facility.

Blue grass. Blue-green was chosen for the landing lights because this color can be seen by pilots at the greatest distances. Frequency must be constant for color fidelity. If the frequency

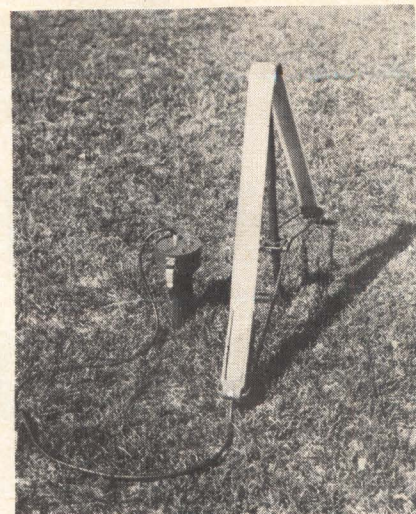

Electroluminescent tapelight marks runways, heliports and drop zones.

rises, the light turns blue; if it goes down the light turns green. To maintain the right color, a modulator is attached to the lamp that converts any frequency used—so long as it's at 110 volts—to 400 hertz. The modulator is controlled by a unijunction transistor to provide stability over a wide range of temperatures.

Strobe effect. A special timer system can be used to provide a rippling, strobe effect and a ¼-second blackout every six seconds. This contrast in illumination enables a pilot to spot an airfield at greater distances. The strobe unit has six timers—one master and five slaves—attached to six green tape-lights. The master timer is a two-wire strobe system producing a square wave that turns on the light for 1½ seconds. A quarter of a second later, a slave timer turns on its light for 1½ seconds, and this is followed by similar action by the third through sixth timers. All the lights then go off for a half-second.

The master timer, a silicon controlled rectifier circuit controlled by a unijunction transistor, is turned off by a capacitor discharge and another unijunction transistor. Unijunction control provides the necessary timing stability over a wide temperature range. The slave timers use standard delay circuits with unijunction transistor controls.

Inverter. The power pack is a plastic case with holders for four 1.5-volt "D" cells and a standard circuit inverter providing an output of 110 volts at 5,000 hertz. It's

Philbrick Operational Amplifiers for comparison shoppers

Compare their prices†

Philbrick		Prices of Comparable Models					
Feature	Model	Price	A	B	C	D	E
Parametric	SP2AU	\$138.	\$195.	—	—	—	—
FET	PP25AU	\$ 79.	\$ 85.	\$ 95.	\$75.	\$85.	\$95.
High performance, high impedance	PP35AU	\$ 54.	\$ 35.	\$ 65.	\$85.	\$42.	—
High performance, ultra-high speed	PP45AU	\$ 89.	—	\$125.	—	\$90.	—
General purpose	PP55AU	\$ 15.	\$ 19.	—	\$18.	\$17.	\$19.
General purpose, high speed	PP55AHU	\$ 19.	\$ 58.	\$ 95.	\$31.	\$35.	—
General purpose, high performance	PP85AU	\$ 25.	\$ 26.	\$ 35.	\$29.	\$24.	\$46.

These Philbrick Operational Amplifiers, which meet more than 70% of all requirements, are available in quantity for immediate delivery. Conservatively-rated, they never fail to deliver the promised performance and reliability. Compare Operational Amplifiers and we know you'll concur . . . Philbrick is usually the lowest priced, always the best value.

†U.S. unit prices from published literature—9/66

For more information, demonstration units, or engineering assistance, call your nearest Philbrick engineering representative or Philbrick Researches, Inc., 22R Allied Drive, Route 128, Dedham, Massachusetts 02026. Phone (617) 329-1600.

ENGINEERING REPRESENTATIVES — **Ala.:** Huntsville (205) 536-8393; **Ariz.:** Phoenix (602) 265-3629; **Cal.:** Los Angeles (213) 937-0780, Mountain View (415) 969-9020, San Diego (714) 222-1121; **Colo.:** Denver (303) 733-3701; **Conn.:** West Hartford (203) 233-5503, Fairfield County (203) 661-5140; **Fla.:** Ft. Lauderdale (305) 564-8000, Ft. Walton Beach (904) 243-6424, Orlando (305) 425-5505; **Ga.:** Tucker (404) 939-1674; **Ill.:** Chicago (312) 676-1100, (312) 676-1101; **Ind.:** Indianapolis (317) 356-4249; **Md.:** Baltimore (301) 727-1999; **Mass.:** Wakefield (617) 245-5100; **Mich.:** Detroit (313) 838-7324; **Minn.:** Minneapolis (612) 545-4481; **Mo.:** Florissant (314) 831-0015; **N.M.:** Albuquerque (505) 268-3941; **N.Y.:** Buffalo (716) 835-6186, DeWitt (315) 446-0220, Valley Stream (516) 561-7791; **N.C.:** Winston-Salem (919) 725-5384, (919) 725-5385; **Ohio:** Dayton (513) 298-9964, Westlake (216) 871-8000; **Okla.:** Tulsa (918) 627-6199; **Pa.:** Conshohocken (215) 277-0559, Pittsburgh (412) 371-1231; **Tex.:** Dallas (214) 526-8316, Houston (713) 781-1441; **Utah:** Salt Lake City (801) 466-4924; **Va.:** Alexandria (703) 836-1800, Newport News (703) 245-8272; **Wash.:** Seattle (206) 723-3320.

EXPORT: N.Y.: (212) 246-2133. Cable: TERMRADIO Telex: 224326 TRIL.

CANADA: Quebec: Montreal (514) 482-9750, Ontario: Toronto (416) 789-4325.

ELECTRONIC ANALOG COMPUTING EQUIPMENT for MODELLING, MEASURING, MANIPULATING and MUCH ELSE



PHILBRICK



A Great Society for Industry?

Right.

And it's located in Louisiana. We figured it was about time somebody made it easier (instead of harder) for industry to turn an honest profit.

The core of our Great Society is some no-nonsense legislation, known as **The Right-To-Profit Laws**. They protect industry, large and small, from unfair taxation and excessive government regulation. In short, they help you make money . . . if you decide to open a plant in Louisiana.

Since our Great Society hasn't received as much publicity as the other one, we'd like to give you some details. If you're interested, write to W. T. Hackett, Department of Commerce and Industry, Room 214, Capitol Annex, Baton Rouge, Louisiana 70804.



The Right-To-Profit State

reported that efficiency is 85%.

The system, originally designed for airstrips handling fixed-wing planes, is being put under considerable stress in Vietnam, where it is used to mark heliports. The wash from a Chinook helicopter on the way down is much stronger than anything the system was built to withstand. Special devices have had to be added to each lamp for protection. Another minor but irritating complaint is that in colder weather it's very hard to plug in or detach the unit's waterproof connector. Refinements are in the works, however, and the next version of the system will probably be designed to provide beacons at any Army air installation.

IV. Nose to the trail

Yet another device from the Aberdeen lab is so sensitive to human effluents—man emits 401 different kinds—that it can detect an ambush before the patrol using it is close enough to be effectively fired upon. This device, which detects increases in the concentration of condensation nuclei in the atmosphere caused by these effluents, can be carried on a man's back or trailed from a low-flying aircraft on the end of a cable. Built by the General Electric Co.'s ordnance department, the detector has also been tested at the Army's Jungle Warfare School in the Republic of Panama.

The manpack system uses a sampler attached to a rifle to pick up submicroscopic agents emitted by human beings. Samples are sent through a tube to the pack unit where they are chemically analyzed and compared to effluents emitted by human beings. If a positive reading results, a transmitter signals a warning by wire to a receiver in the pack bearer's ear.

Researchers at Aberdeen are watching a modification project being undertaken by the Australian army with one of the lab's radios. The lab built four preset channels in the high-frequency AN/PRC-64 radio being used by U.S. Special Forces troops in Vietnam, but the Australians want more. They've asked the developer—the Delco Products division of the Ford Motor Co.—to put a synthesizer in the radio so they can use all the channels in the 2-to-6 Mhz band.

At Sperry Phoenix...when FLEXPRINT[®] Circuitry goes in, the package gets smaller... and costs go down

The design advantages of FLEXPRINT circuitry for Sperry's HZ-6B Attitude Director Indicator were evident from the start. Four thin, custom-engineered FLEXPRINT circuits would replace 67 separate bulky conductors. The finished assembly would then fit into a much smaller package.

The production benefits were less obvious. It took actual experience to demonstrate that attaching connectors and other components to FLEXPRINT circuitry before installation made assembly faster, simpler and error-free . . . and resulted in a reduction of 25% in installed wiring costs.

FLEXPRINT circuits handle like components — can be completely pre-tested, assembled faster, keyed for one-way insertion, and mass produced with precision — at savings over any other interconnection method.

Take advantage of our experience and capabilities in solving interconnection problems at lower installed costs. A FLEXPRINT engineering representative is fully qualified to discuss the best answer to your needs: FLEXPRINT circuitry, FLEXMAX flexible multilayer circuits or INTRAMAX* multilayer hardboard.

Call or write Sanders Associates, Inc., FLEXPRINT Products Division, Grenier Field, Manchester, New Hampshire 03103. Phone: (603) 627-3811

*T.M., Sanders Associates, Inc.

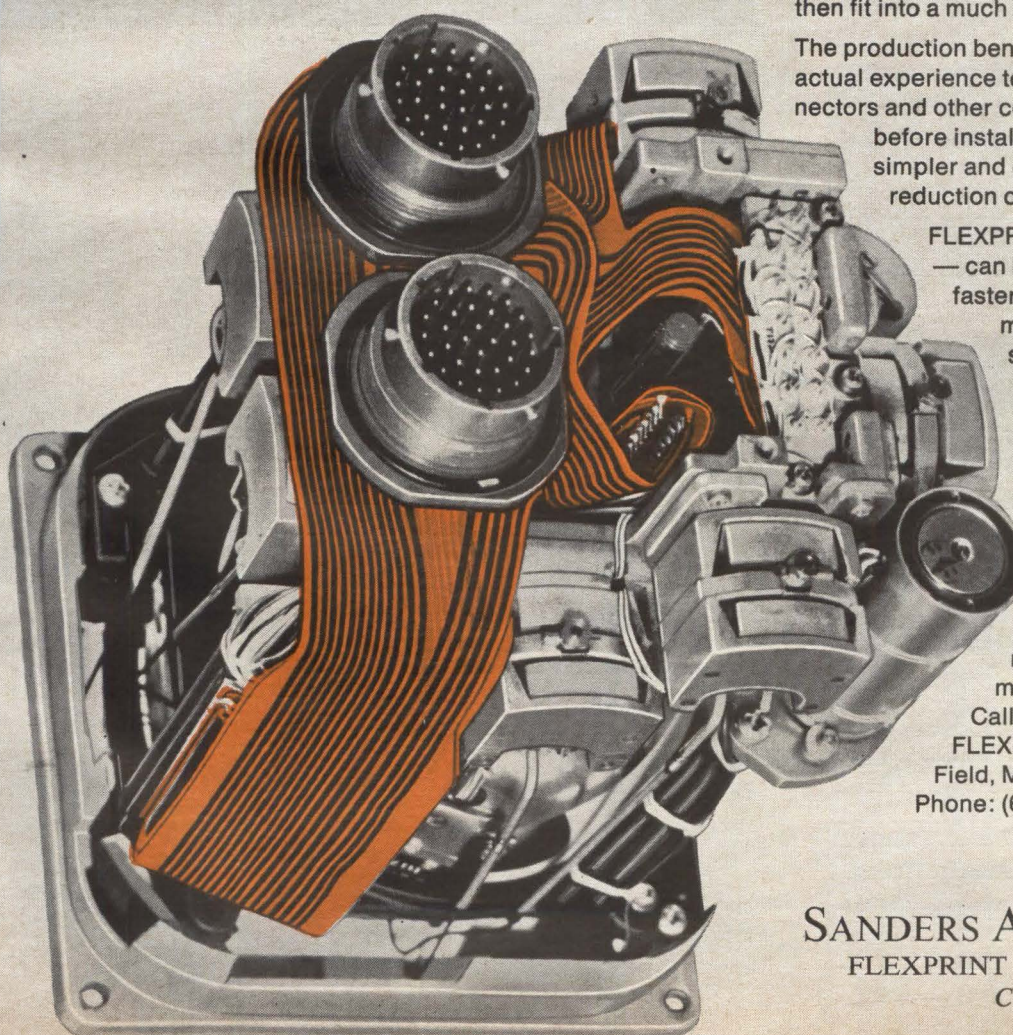

SANDERS ASSOCIATES, INC.
FLEXPRINT PRODUCTS DIVISION



Creating New Directions in Electronics

From the recognized leader in C.P. Clare & Co. introduces

FIVE CONTACTS IN .406 CU.IN.

ISOLATED SWITCHING
... no sensitivity to transients

INHERENT RELIABILITY
... no maintenance

FAST SWITCHING
... high microsecond to low
millisecond range

HIGH SWITCHING CAPACITY
... one to five contacts per relay



Relays, switch, and dime actual size

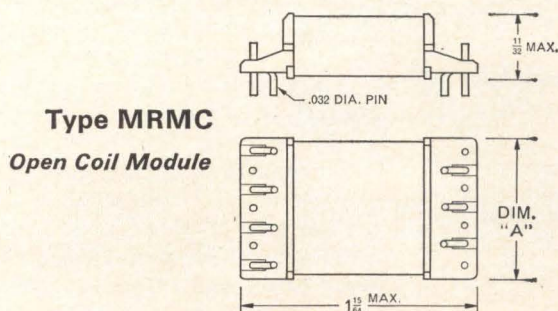
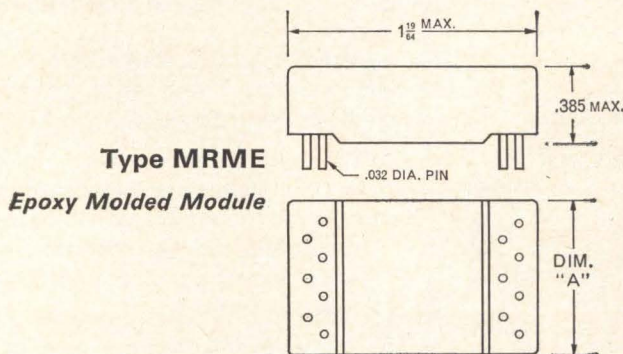

Dimension A—Maximum		
No. of Switches	MRME	MRMC
1	13/32"	11/32"
2	33/64"	29/64"
3	39/64"	35/64"
4	45/64"	21/32"
5	13/16"	3/4"

- Contact arrangements: 1-5 Form A
- Maximum current rating: low level to 750 ma
- Maximum voltage rating: 200 vdc, 110 vac
- Maximum load: 10 va
- Life expectancy: .125 amp, 28v: 10 x 10⁶ operations low level: 100 x 10⁶ operations
- Contact resistance: 100 milliohms max, initial 1 ohm max, after life
- Operate time: .5ms to 2 ms*
- Release time: .5ms max
- Coil voltage: 6 to 48 vdc
- Dielectric standoff: 250 v rms min.
- Insulation resistance: 10,000 megohms min.
- Shock: Type MRME: 50 g
Type MRMC: 20 g
- Vibration: 10 g, 10-2,000 cps
- Temperature: -55°C to + 85°C
(+ 125°C available)

*Including bounce, rating dependent upon number of contacts and drive level

*sealed-contact reed relays—
the new subminiature*

MicroClareed[®]

MRME

and

MRMC

Relays

Outstanding design and production capabilities have made Clareed Relays the recognized standard of quality in sealed contact reed relays. System and circuit designers have shown overwhelming preference for Clareed[®] Relays. And now you can have the same high standards of performance and reliability in only one-fifth the size!

The new MicroClareed Relays offer the identical features and same high quality. Isolation between coil and contacts prevent false actuation due to transient noise. Contacts are sealed in glass in an inert atmosphere under superclean conditions, so there is no contact contamination in manufacture, and complete protection from environmental contamination in use. Their extremely simple design and completely automated production eliminate need for adjustment or maintenance. Precious metal contacts assure long life and low contact resistance. Packaging of both types is ideal for low-profile, high-density printed circuits.

MicroClareed switching speeds (500 microseconds to 2 milliseconds) are completely compatible with other components in most process control applications, and are ample for many systems in instrumentation, circuit check-out, and similar uses.

*For complete information,
ask your Clare sales engineer,
circle the reader service
number shown below, or
write: Group O1N9, C. P.
CLARE & CO., 3101 Pratt
Blvd., Chicago, Illinois 60645*



relays and related control components

IRG



SCR's for Pulse Modulator Circuits

Extremely fast switching at ratings to 700V

IRC's new SCR series features extremely fast switching speeds for pulse modulator applications. Typical turn-on and turn-off times are 0.5 μ sec and 6 μ sec respectively.

These devices offer pulse repetitive frequencies greater than 10 KC, repetitive pulse currents to 130 amps, and switching stability over a wide temperature range.

These types are immediately available from stock:

TYPE	FORWARD BREAKOVER VOLTAGE (DC)	TYPE	FORWARD BREAKOVER VOLTAGE (DC)
NCM 100E	100V, min.	NCM 500E	500V, min.
NCM 200E	200V, min.	NCM 600E	600V, min.
NCM 300E	300V, min.	NCM 700E	700V, min.
NCM 400E	400V, min.		

Other current ratings and a variety of packaging configurations are also available. Write for complete data and prices. IRC, Inc., Semiconductor Division, 401 N. Broad St., Philadelphia, Pa. 19108. (Formerly North American Electronics, Inc.)

CAPSULE SPECIFICATIONS

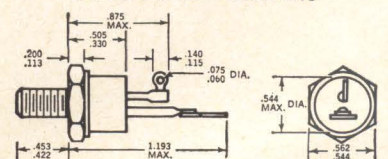

REPETITIVE PULSE CURRENT (I_p)	130A DC, max.
TURN-ON TIME (T_{on}) ($I_p=100A, T_a=25^\circ C$)	1.0 μ sec, max.
TURN-ON VOLTAGE DROP (V_{on}) ($I_p=100A, T_a=25^\circ C$)	25V, max.
TURN-OFF TIME (T_{off}) ($I_p=10A, T_a=100^\circ C$)	10 μ sec, max.
HOLDING CURRENT (I_h)	3 ma, min.
TEMPERATURE RANGE (T_j)	$-65^\circ C$ to $150^\circ C$



Under pressure, transistor becomes transducer

Piezojunction transistor that responds simultaneously to electrical inputs and mechanical pressure can modulate its own output

Serendipitous was the word used to describe the discovery of the piezojunction transistor in 1962, when a Raytheon Co. researcher, scratching away at a transistor to study surface defects, noticed that his probing caused shifts in electrical output.

Now, more than four years later, the first piezoelectric transistors are being produced commercially, not by Raytheon, but by a small spin-off company in Stow, Mass. One of their initial applications is in fluidic systems, to measure operating pressures in turbulence amplifiers.

The device, labeled the Pitran—pronounced π -tran—is being manufactured by Stow Laboratories, a year-old firm organized by Gerhard Doering, who worked on the piezojunction effect while at Raytheon. Claiming it to be the first transducer of any kind that involves an active circuit component, Doering notes that all other transducers use a variable resistor, a capacitor or some similar element. An exception, he recalls, was the not-too-successful tunable grid vacuum

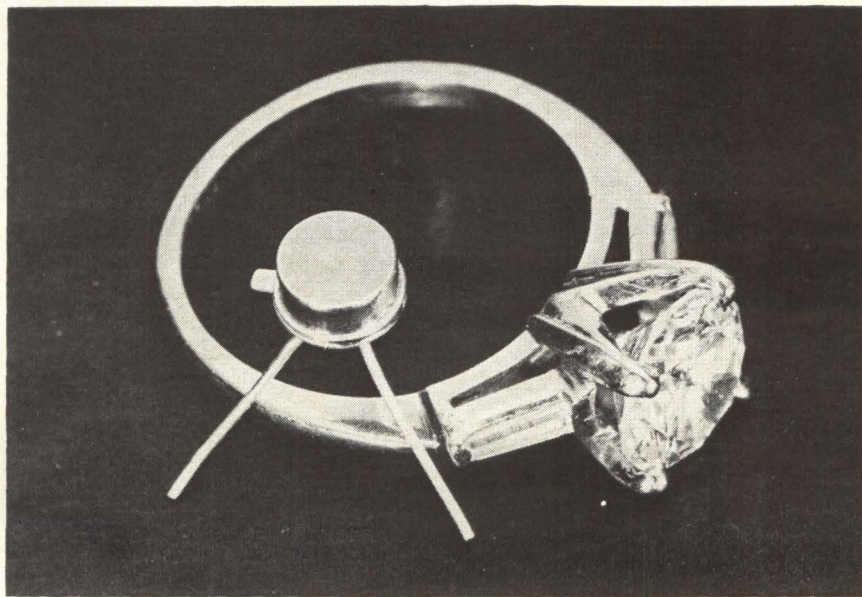

tube of many years ago in which the grid was moved mechanically.

Stow Laboratories' production of Pitran is licensed by Raytheon, which accumulated a broad range of patents on stress-sensitive semiconductor junction devices during the past five years. Raytheon's research program included pressure-sensitive integrated circuits [Electronics, July 12, 1965, p. 81].

The new device can be considered a high-speed silicon switch that has been made sensitive to stress. In the process, Doering concedes, gain is sacrificed. Typical beta is 5, compared to about 20 in today's high-speed switching transistors. The temperature coefficient is higher than that of other transducers—"the price you pay for high sensitivity," says Doering.

The Pitran, he says, permits the superimposing of mechanical variables on electrical variables—the device can react to both simultaneously. The cap of the transistor's TO-46 can is a pressure-sensitive diaphragm. Stress applied to it is transferred to the emitter-base junction, and an electrical output

results. The curve shows how the collector-emitter voltage varies with the amount of pressure applied to the case. The specified linear output range is two volts ($V_{ce} = 2 \pm 1$ volt). The curve is for the circuit shown on the following page.

Since the device is a transistor, it can be conventionally biased for various applications. One of the most useful and simple, says Doering, is a common-emitter d-c amplifier, in which the gain is modulated by a mechanical input. Other applications, he says, involve such digital techniques as a multivibrator circuit whose output is frequency- or pulse-width modulated. Since it is easy to convert PWM into pulse-code modulation, the device is said to be applicable to the latest PCM trends in instrumentation.

The first devices being produced commercially are developmental models and cost \$100 each. "These are the first pressure transducers with a potential for mass production," Doering asserts.

The executive sees a variety of

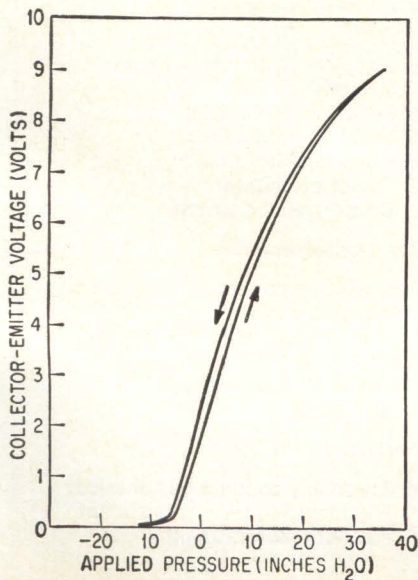

New Products

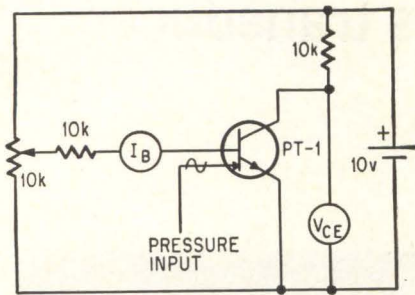

future high-volume applications. "In five years," he says, "it might be the transducer in electronic bathroom scales. In 10 years, with quantity manufacturing bringing the price down, it might be used as a pressure transducer in a vacuum cleaner, to tell the housewife when it is time to empty the bag."

Specifications

Full linear range	1-3v
Overload	500 to 700%
Sensitivity	4v/gram, typical
Linearity over $\pm 1v$ range	1% deviation from best straight line, max
Hysteresis over $\pm 1v$ range	1% deviation between same point on reversing mechanical inputs, max
Mechanical resonant frequency	100 khz
Temperature coefficient	$\pm 20mv/^{\circ}C$, typical
Beta at 5v, 500 μa	5, typical
	50, maximum
Breakdown voltage	120v at 10 μa , typical
Temperature range	-40° to $60^{\circ}C$
Price, developmental model	\$100
Delivery	8 weeks

Stow Laboratories, Inc., Parton Road, Stow, Mass. 01775
Circle [349] on reader service card

Varactors tune out capacitors

Varactor tuning diodes are beginning to replace mechanical tuning capacitors in television and radio receivers. One brand of diodes already used in Germany tv sets are being imported here by ITT Semiconductors [Electronics, December 26, 1966, p. 136].

Now an American manufacturer, the Semiconductor Products division of Motorola Inc., is introducing a line of 16 inexpensive voltage-variable capacitance diodes for the same purpose. All have a minimum tuning ratio of 2 and a maximum of 3.2. Typical capacitance, at 4 volts d-c and a frequency of 1 megahertz, ranges from 6.8 to 100 picofarads. At 4 v d-c and 50 Mhz, the Q ranges from 300 for the low capacitances to 150 for the higher capacitances.

Three to six of the diodes would be needed to replace the mechanical tuning barrel of a tv set. For channels 2 through 13, for example, three diodes could be used, in the oscillator, the radio-frequency stage and r-f mixer.

An additional diode could be used for fine tuning. According to the company, the new diodes can lock onto the carrier frequencies better than any previous method because they will track a station transmitter's allowable drift. The

diodes can also handle the automatic frequency control in a frequency-modulated tuner.

Like all varactors, the new units are more resistant to shock, vibration and careless handling than mechanical capacitors, and they can be placed in any convenient spot in the receiver. In addition, Motorola claims its RamRod construction, which replaces the conventional S-bend cat whiskers as contacts at the junction, makes the diodes more stable mechanically. The technique also results in higher production yields, a spokesman reports, thus helping to reduce prices. Glass DO-7 packages allow the silicon devices to work through a wide temperature range.

Motorola is reluctant to give exact prices, but indicates that sample diodes are priced at about \$1 each.

Specifications

Reverse voltage	20 v
Forward current	250 ma
Dissipation	400 mw at 25 $^{\circ}C$
Junction temperature	175 $^{\circ}C$
Storage temperature range	-65° to 200 $^{\circ}C$
Reverse breakdown voltage	20 v, d-c min at 10 μa
Reverse voltage leakage current	0.1 μa , d-c max at 15 v
Series inductance	10 nhy at 250 Mhz
Case capacitance	0.3 pf at 1 Mhz

Motorola Semiconductor Products Inc., 5005 E. McDowell Rd., Phoenix, Ariz. 85008 [350]

New products in this issue

- 163 Transistor becomes transducer
- 164 Varactors tune out capacitors

Components

- 166 Keep the connector, replace the pin
- 168 Control cable
- 170 Crimp-type lugs
- 172 Low-level choppers
- 174 Subminiature trimmers
- 183 Small r-f capacitors

Semiconductors

- 184 Computer diodes
- 184 Glass zeners
- 184 Low-cost transistors
- 186 Silicon photodetectors
- 187 Photochopper cells

Instruments

- 188 Video amplifier
- 188 Solid state sweeper
- 188 Radar range calibrator
- 189 Peak Power meter
- 190 High-sensitivity counter
- 191 Pressure transducer
- 192 Phase meter and shifter

Subassemblies

- 193 Ambient reference for thermocouples
- 193 Small power supply
- 194 D-c supplies recover rapidly
- 196 Digital plotting system
- 198 Operational amplifier
- 198 Differential amplifier
- 199 Dual plug-in supply

Microwave

- 203 Swept analyzer costs under \$10,000
- 204 Digital phase shifter
- 205 Mixer/preamplifiers
- 206 B-w amplifier tube
- 206 Turret attenuators
- 207 Co-ax transfer switch

Production equipment

- 209 Soldering miniature assemblies
- 210 IC mask maker
- 211 Processing p-c boards
- 212 Coaxial cable stripper
- 214 Machine impregnates armatures

Materials

- 216 Thermally conductive adhesive
- 216 High-temperature encapsulant
- 216 Heat-shrinking tubing

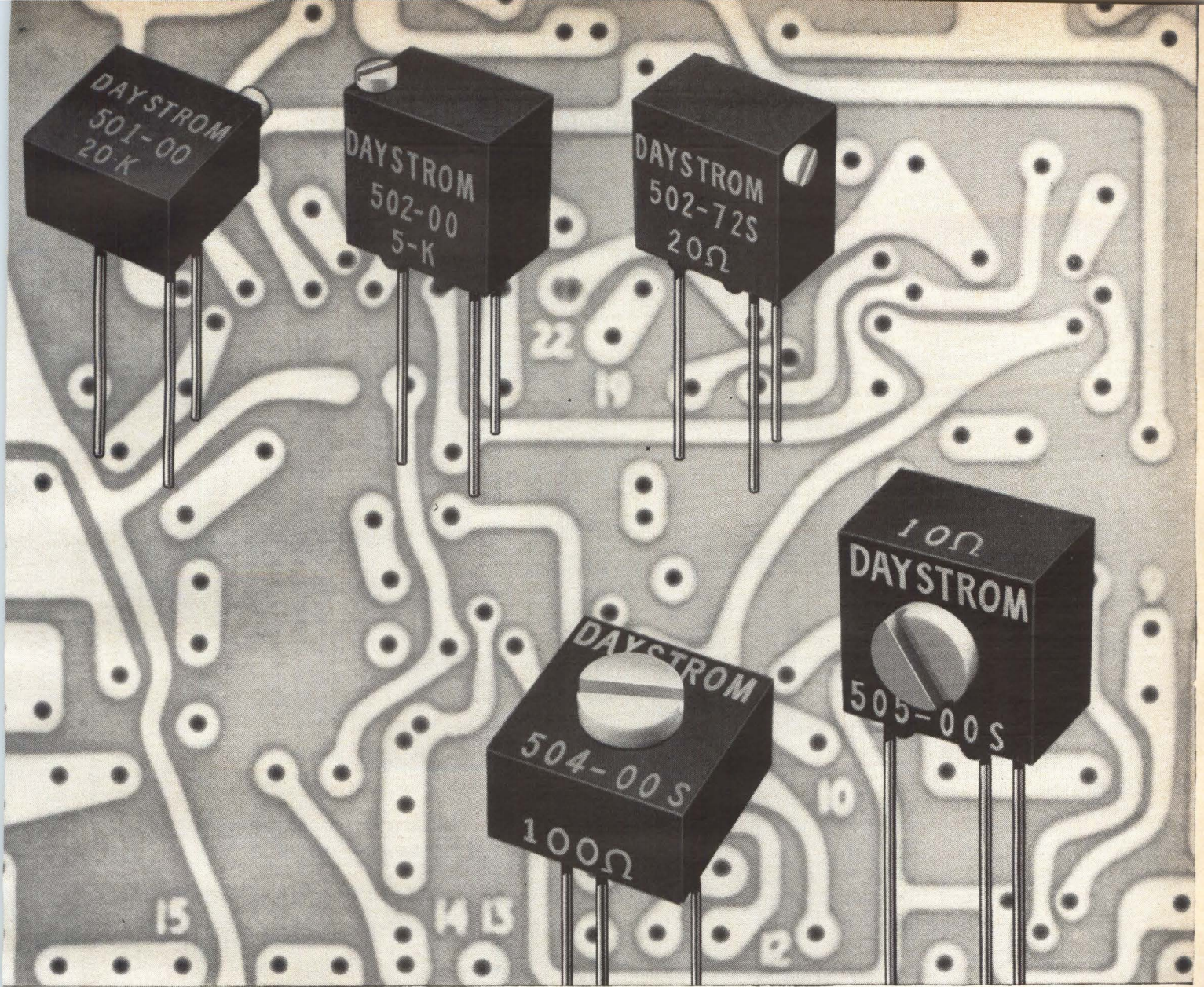

Savings across the board just took a new turn

DAYSTROM Squaretrim® potentiometers now include single-turn types. New models 504 and 505 are fully adjustable with just one turn. Models 501 and 502 are 15-turn types. They all clear up to 80% more PC board space—at no extra cost. But the trim .02 cubic inch size is only one reason why these commercial 500 Series pots are proving so popular. They also feature Weston's exclusive wire-in-the-groove design, and all these performance extras:

Convenience 5 different configurations with adjusting screw on top, side or end • Tolerance $\pm 5\%$ • Adjustability 15 turns or single turn • Slip Clutch eliminates wiper damage, cuts production delays • Suregard™ Terminations (controlled solder) for better protection against vibration, shock and humidity—no pressure taps • Superior Resolution 0.125% or less • Wide Range 10Ω to $20K$ • High Power 0.6 watt in still air at $70^\circ C$ • Wide Temperature Range $-55^\circ C$ to $150^\circ C$ • Low Temperature Coefficient 70 ppm max. • Low Noise 110Ω max. ENR • Small Size $\frac{1}{4}'' \times \frac{1}{4}'' \times \frac{1}{4}''$.

Daystrom potentiometers are another product of:

Weston Instruments, Inc. • Weston-Archbald Division • Archbald, Pa. 18403

WESTON® prime source for precision... since 1888

Circle 165 on reader service card

The more you need from crystal filters, the more you need Bulova!

Today's sophisticated systems call for filters with "difficult" characteristics. Difficult, that is, for everyone but Bulova! Bulova has had so much experience with crystal filters, there's hardly anything we don't know about them;

Take single side-band filters, for example: Attenuation figures alone are not enough to adequately describe today's military communication filters. More and more filters require limitations on envelope time delay, while others must follow a precise time-delay envelope curve.

Bulova has been testing for these parameters — providing measurements both in terms of phase linearity and, in many cases, directly in envelope time-delay readings. As a result,

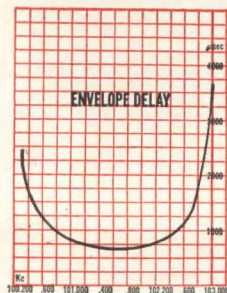

Bulova can engineer and produce to the exact measurements you specify. And at a realistic price!

Proof: Here are the actual curves and specs for just one Bulova filter, Model 562.

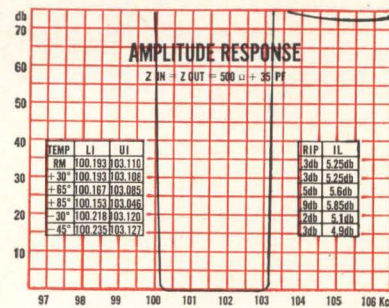

- Bandwidth (1db) 100.255 to 103.035 Kc
- Bandwidth (60 db) 99.990 to 103.260 Kc
- Carrier frequency — is 100 Kc
- Loss at carrier — 55 db min.
- Ultimate attenuation — 70 db
- Max. insertion loss — 6 db
- Max. ripple — 1 db max.
- Operating temperature — -40° to +65°C
- Impedance — 500Ω (in and out)
- Differential envelope time delay — 500 μsec max. over 80% of pass band

With specs like these you can see why we say — the more you need from a filter, the more you need Bulova! Call or write Dept. E-21.

Try Bulova first!

FREQUENCY CONTROL PRODUCTS

ELECTRONICS DIVISION
OF BULOVA WATCH COMPANY, INC.

61-20 WOODSIDE AVENUE
WOODSIDE, N.Y. 11377, (212) DE 5-6000

New Components and Hardware

Keep the connector, replace the pin

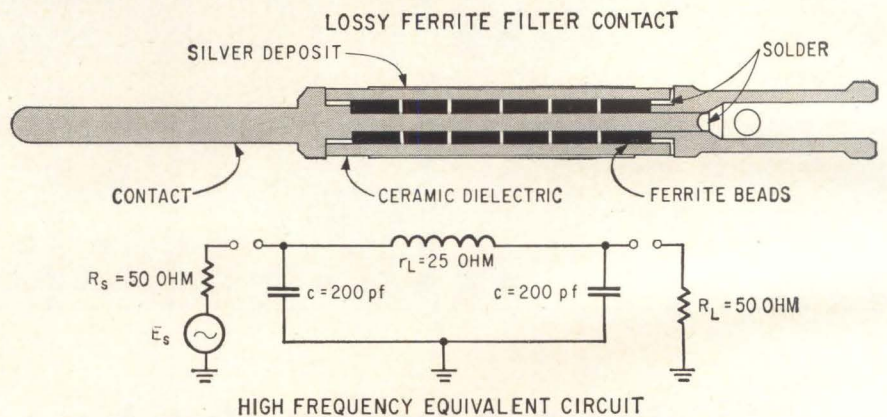
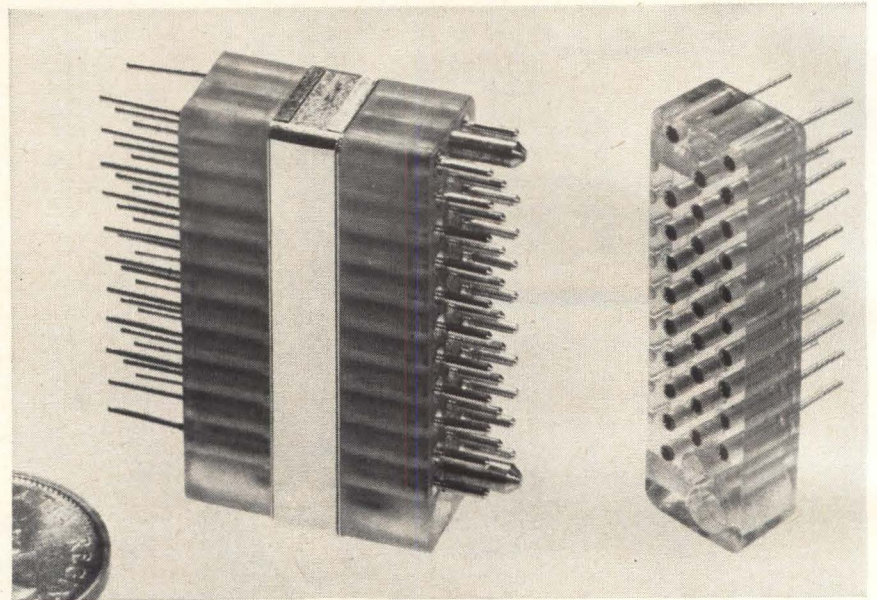

The very high throw-away cost of a defective contact has been the primary disadvantage of filter connectors, according to Amphenol Canada Ltd. With its new connectors, the company says, the user will merely have to replace a \$2 pin, not an entire \$150 connector.

In addition, the Amphenol Corp.'s Canadian subsidiary claims the replaceable-pin connectors are the first filter connectors built to exactly the same size and weight as comparable unfiltered connectors which need external filters.

The basic filtering mechanism isn't new. It is being used by connector manufacturers other than Amphenol Canada. The Amphenol subsidiary, however, has applied its parent firm's patented "Poke Home" field serviceability.

The low-pass filter itself is fabricated by packing ferrite beads between the contact pin and a ceramic dielectric sleeve. A silver deposit on the outside of the ceramic acts as a capacitor ground plate. A microstrip grounding plate, located approximately midway through the connector near the plane of the mounting flange, conducts the unwanted r-f interference to the silver ground.

Prototype samples are available, with full production of four configurations scheduled to begin this year. The first unit to go into production will be a miniature circular connector with contacts on 0.130-inch centers. Although military specifications haven't been set for filter connectors, the initial unit has been designed to meet the re-

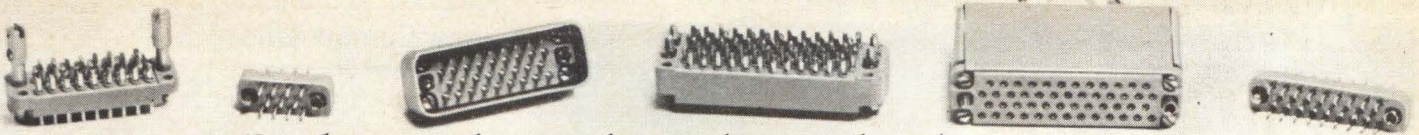

Lightweight rack and panel subminiatures

Series SRM, XSRM. For aircraft, instrumentation and portable equipment. Compact, lightweight rack and panel types. With accessories.



High current capacity subminiatures

Series JF, JFA. For television, radio and communications applications. Flat mounting. With accessories.

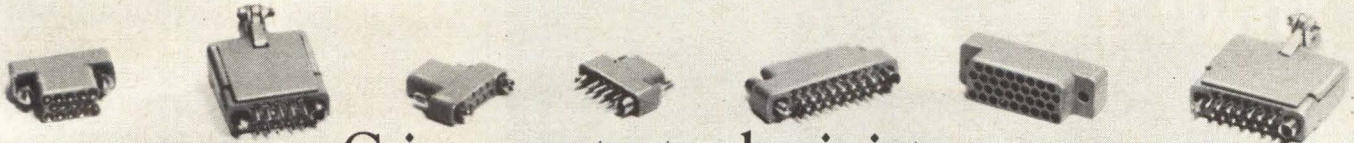

Crimp contact subminiatures

Series SREC. For aircraft, instrumentation and portable equipment. Compact, lightweight rack and panel types. With accessories.

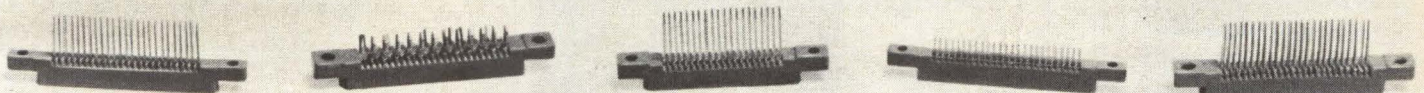

Printed circuit subminiatures

Series PC. For integrated thin film and semiconductor circuitry. With accessories.

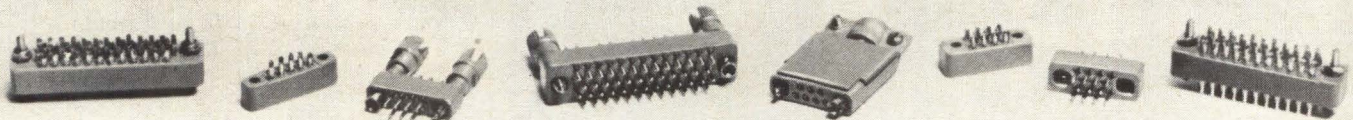

High current rack and panel subminiatures

Series SRE. For applications where current rating or voltage drop requirements dictate large wire size. Meet MIL C 8384. With accessories.

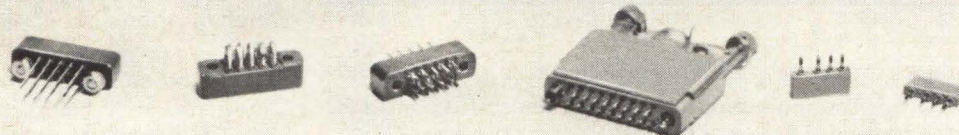

Rack and panel subminiatures

Series SMRE. For airborne and portable applications where space and weight savings are mandatory. High current for size. With accessories.

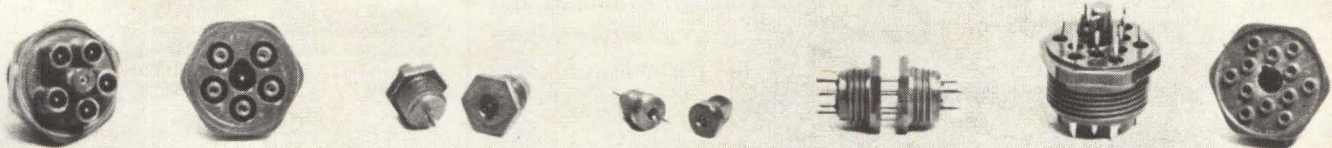

High voltage subminiatures

Series M, PM, SM. For photoflash, aircraft, instrumentation and communications. Single contact. Cable or panel mounted. With accessories.



High contact density subminiatures

Series SRD. For instrumentation, small modular packages, logic units, computers... cable or panel mounting types. With accessories.



how to get your Pulse Generator "made to order" from TI

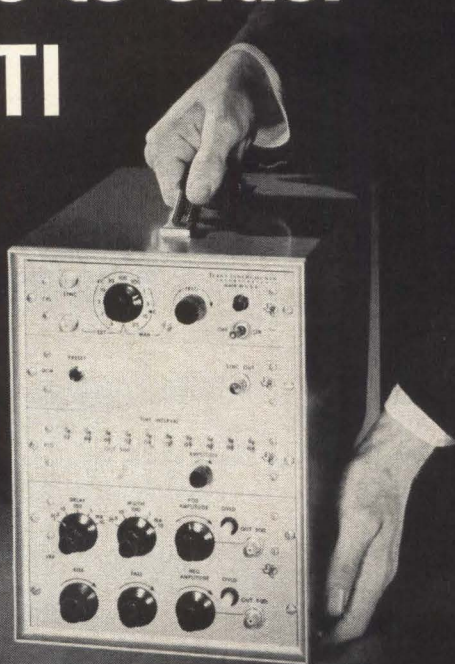

"Special" Pulse Generators are made to order at TI. Modular construction allows assembly of the right building blocks to meet your requirements. Now, "specials" cost you no more, frequently cost less than conventional pulse generators.

For example, the 6613 is an economical general-purpose unit with PRF from 15 cps to 15 mc, priced at only \$950. Another model, the 6325, is a ten-channel, word-bit programmable unit operating up to 25 mc. The single unit does the job of ten discrete generators, at half the cost, and fits in a cabinet 23 in. wide, 38 in. high, 18 in. deep.

TI Pulse Generators give you outstanding performance: PRF's to 100 mc, fast rise and fall times, variable pulse width and delay, variable rise and fall times, plus and minus outputs, pulse mixing, programmed and random word generation. You have your choice of portable or rack-mounting cases.

When you need special pulse generator performance, choose one of the thousands of standard pulse generator combinations from Texas Instruments. For more information, contact your nearest TI Authorized Representative or write to the Industrial Products Group in Houston.

INDUSTRIAL
PRODUCTS
GROUP

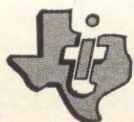

TEXAS INSTRUMENTS
INCORPORATED
P. O. BOX 66027 HOUSTON, TEXAS 77006
118 RUE du RHONE GENEVA, SWITZERLAND

750

New Components

quirements for unfiltered connectors. It will be available only in a size-22 shell, with 61 contacts.

There will be three series of subminiature rectangular connectors, all with contacts spaced on 0.100-inch centers. Two series are designed to withstand temperatures from -55° to 125°C , with one line containing an electrically bonded face seal on the receptacle and plug shells to provide shielding against radiated rfi. The third line, designated economy, is designed for use at room temperatures. The number of contacts will range from 30 to 72.

Even though 90% of the market for this type of connector, currently estimated at \$5 million to \$8 million annually, is in the United States, all production and marketing will be done by Amphenol Canada. Recently, the Canadian government gave the company \$600,000 of aid to ensure that the exportable items would be made in Canada.

The company declines to specify prices at this time for any of the four types of connectors. The rule of thumb, a spokesman says, is to take the price of a standard connector, then add \$2 for each contact to obtain an approximation of the price. The units should, he notes, be somewhat less expensive than ordinary connectors with external filters.

Specifications

Subminiature, rectangular connectors	
Dielectric strength	500 v, dc
Working voltage	200 v, dc at 25°C
Insulation resistance	10,000 megohms, min, at 100 v
Shock	30 g's

Amphenol Canada Ltd., 44 Metropolitan Road, Scarborough, Canada [351]

Control cable saves time and materials

A small-diameter cable for industrial control and instrumentation applications, the 600-v Mini-Trol has a high dielectric, heat-sealed film as primary insulation. This gives higher temperature rating and significant space and weight savings compared to presently

AE's dry-reed switches are soggybobbinproof

On our PC Correeds, we soggy-proof the bobbins by molding them from a fiberglass-reinforced nylon. This strong material is marvelously low in moisture absorption. It keeps its shape even when humidity stays at the saturation point.

That's good to know if you're designing AE Correeds into a piece of remote equipment that must work in a Louisiana bayou. Or anywhere that is exposed to moist atmospheres.

Enough about bobbins. Let's take a look at the "business end" of a PC Correed. We separated the leads from the terminals — to eliminate strain. We *welded* the terminals, for a better electrical

connection than possible with solder.

And for high-density packaging, we have designed low profiles, magnetic shielding and standard printed-circuit terminal spacing (multiples of 0.200").

You can get PC Correeds with 1, 2, 3 and 5 reedcapsules. In contact forms A, B, C and magnetic latching. Many of these modules are available directly from stock. Soggy-proof bobbin and all.

Could you use some helpful new design information? Ask your nearby AE representative for Circular 1070-B.

Or write to the Director, Electronic Control Equipment Sales, Automatic Electric Company, Northlake, Ill. 60164.



AUTOMATIC ELECTRIC
SUBSIDIARY OF
GENERAL TELEPHONE & ELECTRONICS **GTE**

General Electric... Top Source for Semiconductor Parts



General Electric is geared to produce a broad line of semiconductor parts. Make G. E. your one source for all components such as:

Component Assemblies—Semiconductor lead-in wires—Dumet "slug" leads—molybdenum "slug" leads—whisker welds and other 2 or 3 part welded lead wires—molybdenum diode slugs—plastic transistor headers—plastic integrated circuit packages.

Lead and Interconnection Wires—Tungsten, molybdenum, and borated Dumet wire for glass to metal sealing—unborated and gold plated Dumet for interconnections and "pigtail" leads—tungsten and molybdenum whisker wire, bare or gold plated.

Sheet and Discs—Molybdenum and tungsten sheet—molybdenum and tungsten discs (punched, pressed and sintered, cut from rod).

Evaporative Sources for Functional Coatings—Stranded tungsten metallizing wire and coils—tungsten and molybdenum boats.

And More! Get all the data. Write or call for our new booklet "Products for the Semiconductor Industry." General Electric Lamp Metals & Components Dept., 21800 Tungsten Rd., Cleveland, Ohio 44117. Tel: (216) 266-2970

Progress Is Our Most Important Product

GENERAL  ELECTRIC

New Components

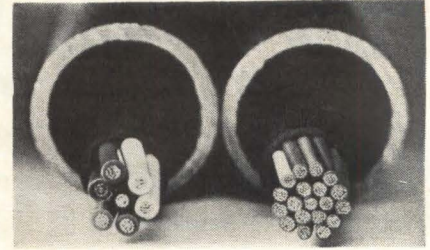

available small industrial control cables. The 7-mil insulation actually outperforms standard 30-mil polyethylene insulation, according to the manufacturer.

The Mini-Trol construction also provides savings in time, labor and materials when adding circuits to existing installations or constructing new installations. For example, a standard 7-conductor, 19/12 Awg cable requires the same one-inch conduit as the new Mini-Trol 19-conductor cable. Application of Mini-Trol cable, therefore, increases conduit capacity from 2½ to 3 times.

The polyester insulation used on Mini-Trol cable has a temperature rating of 105° C, with outstanding cut-through and abrasion resistance over a broad temperature range, the company says.

Rockbestos Wire & Cable Co., division of Cerro Corp., Nicoll & Canner Sts., New Haven, Conn., 06504. [352]

Polyvinyl chloride crimp-type lugs

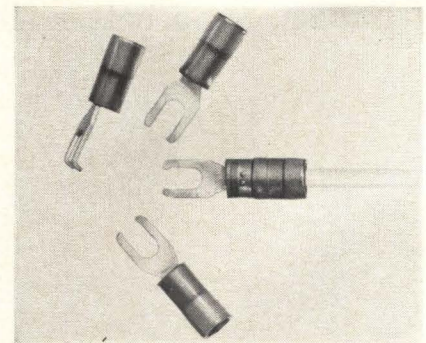

Two insulated Sta-Kon wire lugs are applicable to connecting blocks that have reduced clearances between barriers in electrical and electronic installations. Both are insulated with polyvinyl chloride (PVC).

The RB197 is a solderless forked

Here's how to get more cooling with less size and weight:

Use Garrett-AiResearch "ICE"

The Garrett-AiResearch systems approach to "black box" cooling is called Integrated Cooling for Electronics ("ICE"). It can save you development dollars, cut system weight, and reduce circuit enclosure size.

Simply give us your circuit design heat transfer problem and we'll do the rest: trade-off studies, interface details, heat transfer system design, and manufacturing.

You'll get an optimized system with minimum power consumption for maximum cooling, and a compact, lightweight chassis with an

integral or separate heat transport loop or heat pump.

If you're developing electronics circuits for space vehicles, weapons systems, aircraft or ground communications, or other critical applications, call in AiResearch while your package is being conceived; we'll work with you to match an "ICE" system to your specific needs. Contact AiResearch Manufacturing Company, 9851 Sepulveda Blvd., Los Angeles, California 90009.

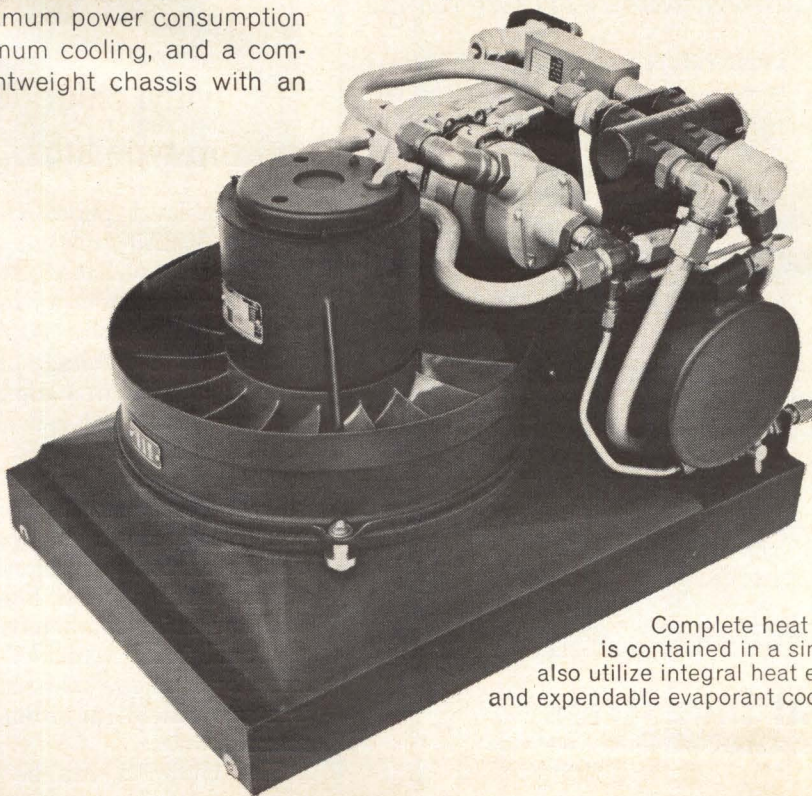

Complete heat transport system (left) is contained in a single, compact unit. We can also utilize integral heat exchangers, heat pumps, and expendable evaporant cooling methods.

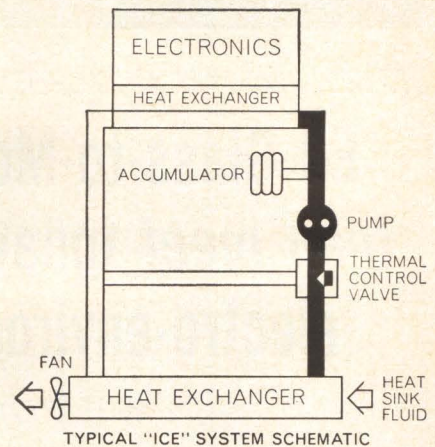

This AiResearch "ICE" system includes both the heat transport system and electronics enclosure with integrated heat exchanger.

GARRETT AiResearch
Heat
Transfer Systems

"Another unusual hermetic seal problem?"



STANDARD TYPES AND SPECIALS —

E-I Glass-to-Metal Seals *more than meet today's highly critical electro-environmental specs*

— IN MILITARY/COMMERCIAL APPLICATIONS!

Service-proven in every type of electrical and electronic requirement, E-I hermetic seals are finding even wider application in the more sophisticated under-sea/aero-space instruments, equipment and systems. These high dielectric strength seals are being produced to meet unusually severe shock and vibration conditions, and wide fluctuations in

temperature and humidity. E-I glass-to-metal terminations offer the advantages of vacuum-tight sealing with maximum rigidity and durability, miniaturization and design standardization. Where custom seals or unusual lead configurations are required, E-I sales engineers will make recommendations from your blueprints, sketches or data.

Write for the E-I Catalog — A practical, concise volume edited and compiled for the engineer / designer / specifier. Contains data and specifications covering a diversity of glass-to-metal seals in a wide range of types and sizes, including hundreds of stock items. Please address requests on company letterhead.

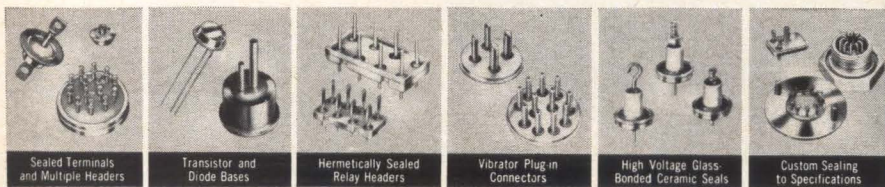

Electrical Industries

A Division of Philips Electronics and Pharmaceutical Industries Corp.
Murray Hill, N. J. 07971 — Tel. (201) 464-3200

Patented in U.S.A., No. 3,035,372; in Canada, No. 523,390; in United Kingdom, No. 734,583; other patents pending.

New Components

tongue, copper lug with turned-up toes, which fit most narrow barrier blocks. The toes are turned up to retain the lug under the number 6 screw head, thereby making it semicaptive, which is not the case with a straight forked tongue type.

The RB1347 is a solderless ring tongue lug, which has a tongue width of 0.25 in. to accommodate a number 8 stud. This lug has been made to fit the narrow barrier of blocks.

The lugs are fabricated of high-conductivity copper and are electro-tin plated. Both can be installed with a standard hand tool such as WT445 or new automatic crimping tools, and can be used on number 16 to number 14 wires.

The Thomas & Betts Co., 36 Butler St., Elizabeth, N.J., 07207. [353]

Low-level choppers have electrostatic shielding

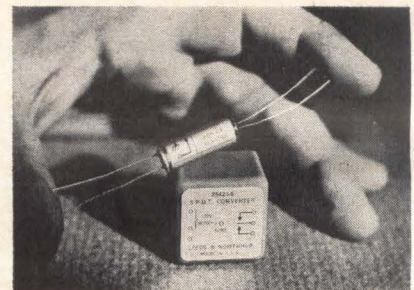

Two low-level photo choppers—models 354256 (spst) and 354258 (spdt)—are available as components for measurement and control circuitry. The solid state devices feature low d-c voltage offset (less than 1 μ v); electrostatic shielding between lamp and cells; a life of 25,000 to 50,000 hours.

The company says that careful selection of materials, proper physical arrangement of parts and closely controlled production techniques have assured low thermal and low noise characteristics. The photocell is fully shielded from the lamp by a unique transparent electrostatic shield, according to the manufacturer.

The choppers can be mounted either vertically or horizontally and

**Tracor has been looking
closely at your
specialized
instrument needs.**

**You may want to look
at what we have come
up with for you.**

You may be surprised.

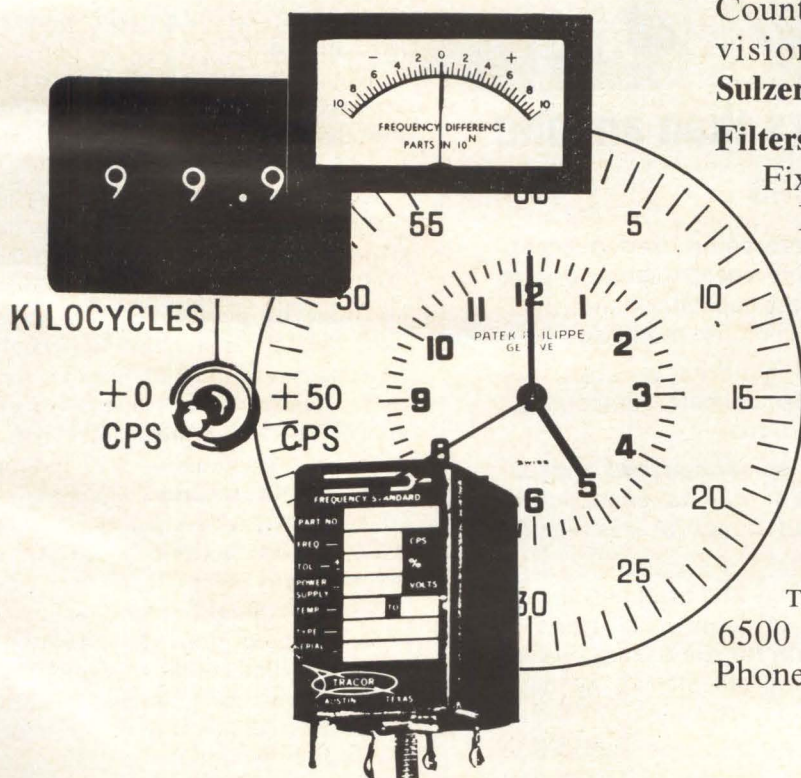

No matter what your specialized field of interest may be . . . more and more you'll find TRACOR or one of its affiliated companies ready to meet your requirements with precision-quality industrial instruments. Here, briefly, is a summary of TRACOR . . . its products, and the companies which make them.

Time and Frequency Instruments: Omega Navigation Systems, VLF/LF Phase Tracking Receivers, Linear Phase/Time Comparators, Omega Commutators, Frequency Difference Meters, Frequency Distribution Systems, Tuning Fork Oscillators . . . by TRACOR.

Atomic Standards: Rubidium Frequency Standards, Portable Atomic Clocks, Tactical Atomic Clocks, Time Scale Selectors, Stand-by Power Supplies . . . by General Technology Corporation.

Crystal Standards and Components: Crystal Frequency Standards, Crystal Oscillators, Portable Crystal Clocks, Magnetic Counters, Plug-in Decade Counters, Television Synchronization Systems . . . by Sulzer Laboratories.

Filters and Analyzers: Variable Filters, Fixed Filters, Amplifiers, Noise Sources, Power Supplies, Equalizers, Spectrum Shapers, Analyzers . . . by Allison.

Display Instruments: Digital Memory Oscilloscopes, Pulse Height Analyzers . . . by Northern Scientific.

Can TRACOR play a part in your industrial instruments requirement? Give us a try and see. Contact: TRACOR, Inc., General Sales Offices, 6500 Tracor Lane, Austin, Texas 78721. Phone 512 926-2800.

TFA-1566A

**More and more you'll
find advanced technology from**



HOW

to solve your electronic component packaging problems...

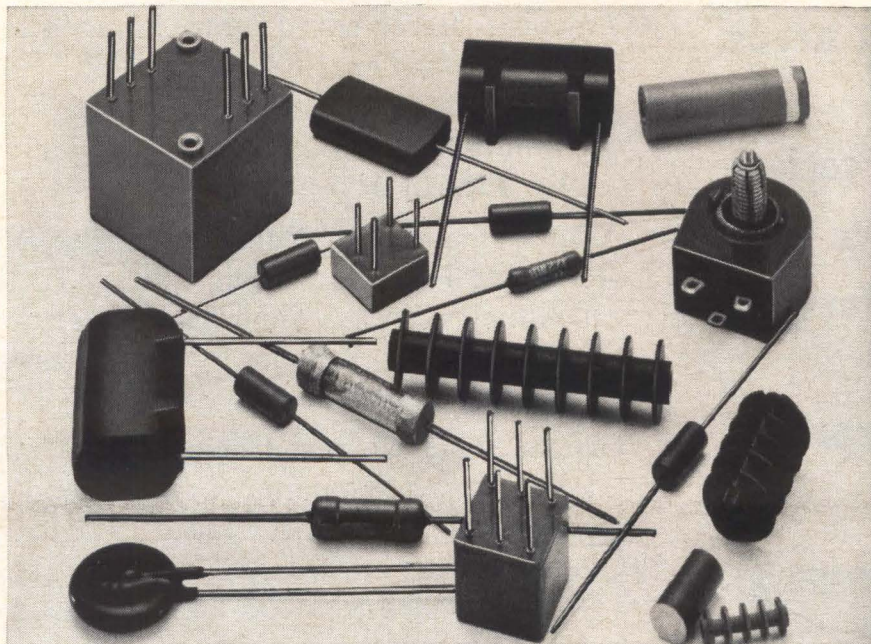

HYSOL has more answers than anyone in the business

HYSOL HYFLO® epoxy molding powders are being used, successfully and economically, for transfer molding encapsulation of just about every type of component, from tiniest capacitors and precision resistors to large transformers and complex modules.

HYSOL liquid epoxy systems, in several hundred varieties, are being used for casting or potting the most delicate components. Most compatibility problems can be solved, too.

HYSOL DRI-KOTE® POWDERS, for spray or aerated bed application offer a particularly fast, economical way to encapsulate components that can withstand elevated temperatures during manufacture.

Our experience in the entire spectrum of epoxy and urethane encapsulating techniques, and our background in depth in all types of epoxy powder and liquid systems, are yours for the asking. Let us work to develop the best answer to your problems, as we have already done for scores of leading manufacturers.

Call, write or wire HYSOL today for technical data and application engineering assistance. Ask for Bulletins E3-100, E7-100 and E8-900.1.

PROGRESSIVE PRODUCTS
HYSOL HYSOL CORPORATION • OLEAN, NEW YORK
THRU CHEMICAL RESEARCH LOS ANGELES, CALIFORNIA/HYSOL (CANADA) LTD., ONTARIO/LONDON, ENGLAND

New Components

are designed to operate with good efficiency with a wide range of circuit impedances in various circuit configurations. Both the 354256 (tubular design) and the 354258 (flat-package, plug-in design) are suited for 60-hz applications.

Leeds & Northrup Co., Components division, North Wales, Pa., 19454. [354]

Subminiature trimmers meet MIL-R-27208A

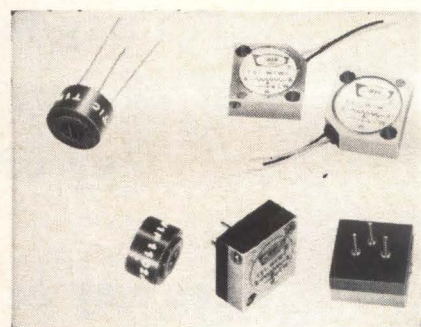

Two series of subminiature trimmers are designed for compact, solid state circuitry and plug-in card modules.

The "transistor can" TTL units are less than $\frac{1}{3}$ in. in diameter and less than $\frac{1}{5}$ in. high. Fifty of them would weigh about an ounce.

Equipped with gold-plated solid pin connectors and precious metal wipers, the low-noise single-turn TTL units are rotated, potentiometer-like, by a slotted shaft flush with the top of the trimmer. High shaft torque of 5 oz-in. assures setting stability under severe shock and vibration conditions. The trimmers are available in six standard resistance values from 500 ohms to 10,000 ohms, with resolutions from 0.4% to 0.18%. Power rating is 0.5 w from -65° to $+70^{\circ}$ C.

Square series TSI units offer a choice of gold-plated base pins for mounting and connection, or flexible Teflon-insulated stranded leads, and are manufactured in nine standard values from 50 ohms to 20,000 ohms, with resolutions as high as 0.12%.

TSI trimmers weigh 2.5 grams, are $\frac{1}{2}$ x $\frac{1}{2}$ -in. square and are adjusted by a 42-turn stainless steel

DICKSON

A FULL HOUSE ...

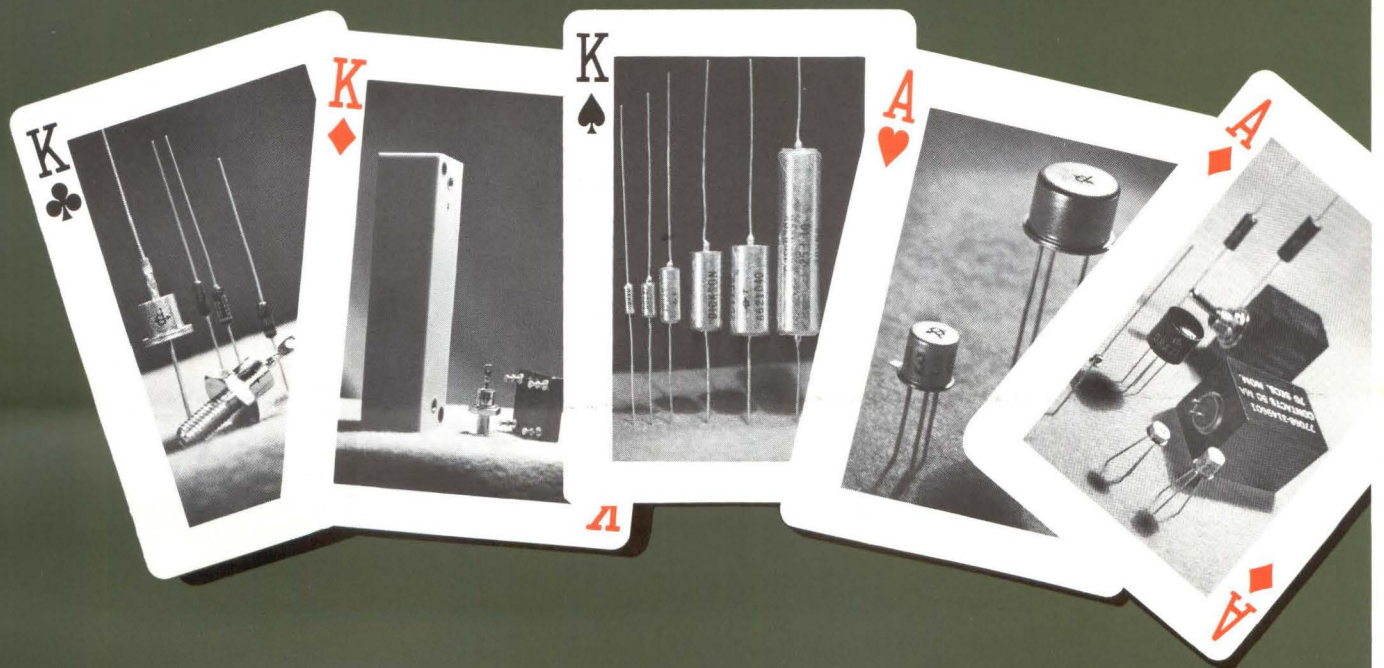

... OF ZENER DIODES, HIGH-VOLTAGE RECTIFIERS,
TANTALUM CAPACITORS ... AND A SELECT GROUP OF
SILICON TUNNEL DIODES, SILICON RESISTORS, FETS,
SOLID STATE CIRCUIT BREAKERS AND TIME DELAY RELAYS



DICKSON ELECTRONICS CORPORATION
P.O. BOX 1390 SCOTTSDALE, ARIZONA 85252 PHONE (602) 947-5751

TYPE	V _Z @ I _{ZT}		ΔV _{ZT} Max. mV	Maximum Dynamic Impedance Ohms	Effective Temperature Coefficient %/°C	TYPE	V _Z @ I _{ZT}		ΔV _{ZT} Max. mV	Maximum Dynamic Impedance Ohms	Effective Temperature Coefficient %/°C	TYPE	V _Z @ I _{ZT}		ΔV _{ZT} Max. mV	Maximum Dynamic Impedance Ohms	Effective Temperature Coefficient %/°C
	Volts	mA					Volts	mA					Volts	mA			
1N4057	12.4	10.0	96	25	.005	1N4067	43.0	7.5	333	90	.005	1N4077	100.0	5.0	785	340	.005
1N4057A	12.4	10.0	39	25	.002	1N4067A	43.0	7.5	133	90	.002	1N4077A	100.0	5.0	310	340	.002
1N4058	14.6	10.0	113	30	.005	1N4068	47.0	7.5	364	100	.005	1N4078	105.0	2.5	815	700	.005
1N4058A	14.6	10.0	45	30	.002	1N4068A	47.0	7.5	146	100	.002	1N4078A	105.0	2.5	326	700	.002
1N4059	16.8	10.0	130	30	.005	1N4069	51.0	7.5	395	110	.005	1N4079	110.0	2.5	854	740	.005
1N4059A	16.8	10.0	53	30	.002	1N4069A	51.0	7.5	158	110	.002	1N4079A	110.0	2.5	342	740	.002
1N4060	18.5	10.0	143	30	.005	1N4070	56.0	7.5	434	120	.005	1N4080	120.0	2.5	930	800	.005
1N4060A	18.5	10.0	58	30	.002	1N4070A	56.0	7.5	174	120	.002	1N4080A	120.0	2.5	372	800	.002
1N4061	21.0	10.0	163	35	.005	1N4071	62.0	7.5	482	135	.005	1N4081	130.0	2.5	1008	840	.005
1N4061A	21.0	10.0	65	35	.002	1N4071A	62.0	7.5	193	135	.002	1N4081A	130.0	2.5	403	840	.002
1N4062	23.0	10.0	178	40	.005	1N4072	68.0	5.0	528	230	.005	1N4082	140.0	2.5	1085	960	.005
1N4062A	23.0	10.0	72	40	.002	1N4072A	68.0	5.0	211	230	.002	1N4082A	140.0	2.5	1160	1020	.005
1N4063	27.0	10.0	210	45	.005	1N4073	75.0	5.0	582	250	.005	1N4083	150.0	2.5	1160	1020	.005
1N4063A	27.0	10.0	84	45	.002	1N4073A	75.0	5.0	233	250	.002	1N4083A	150.0	2.5	465	1020	.002
1N4064	30.0	10.0	233	50	.005	1N4074	82.0	5.0	636	270	.005	1N4084	175.0	2.5	1360	1150	.005
1N4064A	30.0	10.0	93	50	.002	1N4074A	82.0	5.0	254	270	.002	1N4084A	175.0	2.5	543	1150	.002
1N4065	33.0	10.0	256	55	.005	1N4075	87.0	5.0	675	290	.002	1N4085	200.0	2.5	1550	1350	.005
1N4065A	33.0	10.0	103	55	.002	1N4075A	87.0	5.0	270	290	.002	1N4085A	200.0	2.5	620	1350	.002
1N4066	37.0	7.5	209	80	.005	1N4076	91.0	5.0	705	310	.002						
1N4066A	37.0	7.5	115	80	.002	1N4076A	91.0	5.0	283	310	.002						

ULTRA-STABLE CERTIFIED REFERENCE DIODES

TYPE	ΔV _{ZT} Max. mV	over	Temp. Range °C	Maximum Dynamic Impedance Ohms	Voltage Time Stability ΔV _{ZT} μV/1000 hrs.	Effective Voltage Time Stability PPM/1000 hrs.	TYPE	ΔV _{ZT} Max. mV	over	Temp. Range °C	Maximum Dynamic Impedance Ohms	Voltage Time Stability ΔV _{ZT} μV/1000 hrs.	Effective Voltage Time Stability PPM/1000 hrs.
250 mW, V_Z 6.2-6.5 V (I_Z 7.5 mA) CASE 1 GLASS													
1N3501	6		+25 to +100	12	636	100	1N3503	6		+25 to +100	12	318	50
1N3502	3		+25 to +100	12	636	100	1N3504	6		+25 to +100	12	127	20
400 mW, V_Z 6.35 V ±5% (I_Z 7.5 mA) CASE 1 GLASS													
1N4890	5.0		+25 to +100	10	318	50	1N4893	2.5		+25 to +100	10	127	20
1N4890A	10.0		-55 to +100	10	318	50	1N4893A	5.0		-55 to +100	10	127	20
1N4891	2.5		+25 to +100	10	318	50	1N4894	5.0		+25 to +100	10	64	10
1N4891A	5.0		-55 to +100	10	318	50	1N4894A	10.0		-55 to +100	10	64	10
1N4892	5.0		+25 to +100	10	127	20	1N4895	2.5		+25 to +100	10	64	10
1N4892A	10.0		-55 to +100	10	127	20	1N4895A	5.0		-55 to +100	10	64	10

PRECISION VOLTAGE TOLERANCE, TEMPERATURE COMPENSATED ZENER DIODES

TYPE	ΔV _{ZT} Max. mV	over	Temp. Range °C	Dynamic Impedance Ohms (Maximum)	Effective Temperature Coefficient %/°C	TYPE	ΔV _{ZT} Max. mV	over	Temp. Range °C	Dynamic Impedance Ohms (Maximum)	Effective Temperature Coefficient %/°C
400 mW, V_Z 9.8-10.2 V (I_Z 10 mA) Suffix "A" denotes V_Z 9.9-10.1 V CASE 1											
1N4295	0 to +246		-55 to +150	20	+0.12	1N4296	0 to +246		-55 to +150	10	+0.12
1 WATT, V_Z 9.8-10.2 V (I_Z 20 mA) Suffix "A" denotes V_Z 9.9-10.1 V CASE 2											

HIGH POWER TEMPERATURE COMPENSATED REFERENCE DIODES

TYPE	ΔV _{ZT} Max. mV	over	Temp. Range °C	Maximum Dynamic Impedance Ohms	Effective Temperature Coefficient %/°C	TYPE	ΔV _{ZT} Max. mV	over	Temp. Range °C	Maximum Dynamic Impedance Ohms	Effective Temperature Coefficient %/°C
10 WATTS, V_Z 8.8 V ±5% (I_Z 150-250 mA) CASE 4 METAL											
1N4297	66		0 to +75	1.4	.01	1N4297B	180		-55 to +150	1.4	.01
1N4297A	136		-55 to +100	1.4	.01	1N4298	33		0 to +75	1.4	.005
1N4298A	68		-55 to +100	1.4	.005	1N4298B	90		-55 to +150	1.4	.005
10 WATTS, V_Z 11.3 V ±5% (I_Z 110-190 mA) CASE 4 METAL											
1N4299	85		0 to +75	1.6	.01	1N4299B	232		-55 to +150	1.6	.01
1N4299A	175		-55 to +100	1.6	.01	1N4300	43		0 to +75	1.6	.005
1N4300A	88		-55 to +100	1.6	.005	1N4300B	116		-55 to +150	1.6	.005
50 WATTS, .8.8 V ±5% (I_Z 750-1250 mA) CASE 6 METAL											
1N4301	66		0 to +75	.6	.01	1N4301B	180		-55 to +150	.6	.01
1N4301A	136		-55 to +100	.6	.01	1N4302	33		0 to +75	.6	.005
1N4302A	68		-55 to +100	.6	.005	1N4302B	90		-55 to +150	.6	.005
50 WATTS, 11.3 V ±5% (I_Z 550-950 mA) CASE 6 METAL											
1N4303	85		0 to +75	.8	.01	1N4303B	232		-55 to +150	.8	.01
1N4303A	175		-55 to +100	.8	.01	1N4304	43		0 to +75	.8	.005
1N4304A	88		-55 to +100	.8	.005	1N4304B	116		-55 to +150	.8	.005

CHIP ZENER DIODES

CFA SERIES, CHIP SIZE 0.025 x 0.025

TYPE	Nominal Voltage V _Z @ I _{ZT} Volts	Test Current I _{ZT} μA	Maximum Impedance Z _T @ I _{ZT} Ohms	TYPE	Nominal Voltage V _Z @ I _{ZT} Volts	Test Current I _{ZT} μA	Maximum Impedance Z _T @ I _{ZT} Ohms	TYPE	Nominal Voltage V _Z @ I _{ZT} Volts	Test Current I _{ZT} μA	Maximum Impedance Z _T @ I _{ZT} Ohms	TYPE	Nominal Voltage V _Z @ I _{ZT} Volts	Test Current I _{ZT} μA	Maximum Impedance Z _T @ I _{ZT} Ohms
CFA6.8D5	6.8	250	200	CFA12D5	12	250	200	CFA18D5	18	250	200	CFA27D5	27	250	200
CFA7.5D5	7.5	250	200	CFA13D5	13	250	200	CFA19D5	19	250	200	CFA28D5	28	250	200
CFA8.2D5	8.2	250	200	CFA14D5	14	250	200	CFA20D5	20	250	200	CFA30D5	30	250	200
CFA9.1D5	9.1	250	200	CFA15D5	15	250	200	CFA22D5	22	250	200	CFA33D5	33	250	200
CFA10D5	10	250	200	CFA16D5	16	250	200	CFA24D5	24	250	200				
CFA11D5	11	250	200	CFA17D5	17	250	200	CFA25D5	25	250	200				

CFC SERIES, CHIP SIZE 0.025 x 0.025

TYPE	Nominal Voltage V _Z @ I _{ZT} Volts	Test Current I _{ZT} mA	Maximum Impedance Z _T @ I _{ZT} Ohms	TYPE	Nominal Voltage V _Z @ I _{ZT} Volts	Test Current I _{ZT} mA	Maximum Impedance Z _T @ I _{ZT} Ohms	TYPE	Nominal Voltage V _Z @ I _{ZT} Volts	Test Current I _{ZT} mA	Maximum Impedance Z _T @ I _{ZT} Ohms	TYPE	Nominal Voltage V _Z @ I _{ZT} Volts	Test Current I _{ZT} mA	Maximum Impedance Z _T @ I _{ZT} Ohms
CFC6.8D5	6.8	18.5	4.5	CFC12D5	12	10.5	11.5	CFC18D5	18	7.0	21	CFC27D5	27	4.6	41
CFC7.5D5	7.5	16.5	5.5	CFC13D5	13	9.5	13.0	CFC19D5	19	6.5	23	CFC30D5	30	4.2	49
CFC8.2D5	8.2	15.0	6.5	CFC14D5	14	9.0	14.5	CFC20D5	20	6.2	25	CFC33D5	33	3.8	58
CFC9.1D5	9.1	14.0	7.5	CFC15D5	15	8.5	16	CFC22D5	22	5.6	29				
CFC10D5	10	12.5	8.5	CFC16D5	16	7.8	17	CFC24D5	24	5.2	33				
CFC11D5	11	11.5	9.5	CFC17D5	17	7.2	19	CFC25D5	25	5.0	37				

TYPE	ΔV_{ZT} Max. mV	over	Temp Range °C	Maximum Dynamic Impedance Ohms	Effective Temperature Coefficient %/°C	TYPE	ΔV_{ZT} Max. mV	over	Temp Range °C	Maximum Dynamic Impedance Ohms	Effective Temperature Coefficient %/°C	TYPE	ΔV_{ZT} Max. mV	over	Temp Range °C	Maximum Dynamic Impedance Ohms	Effective Temperature Coefficient %/°C															
400 mW, V_Z 8.4 V $\pm 5\%$ (I_Z 10 mA) CASE 1 GLASS																																
1N3154	130	-55 to +100	15	.01	1N3155A	86	-55 to +150	15	.005	1N3157	13.0	-55 to +100	15	.001	1N3154A	172	-55 to +150	15	.01	1N3156	26	-55 to +100	15	.002	1N3157A	17.0	-55 to +150	15	.001			
1N3155	65	-55 to +100	15	.005	1N3156A	34	-55 to +100	15	.002																							
500 mW, V_Z 9.0 V $\pm 5\%$ (I_Z 7.5 mA) CASE 1 GLASS																																
1N935	67	0 to +75	20	.01	1N937	13	0 to +75	20	.002	1N939	3.4	0 to +75	20	.0005	1N935A	140	-55 to +100	20	.01	1N937A	28	-55 to +100	20	.002	1N939A	7.0	-55 to +100	20	.0005			
1N935B	184	-55 to +150	20	.01	1N937B	37	-55 to +150	20	.002	1N939B	9.2	-55 to +150	20	.0005	1N936	33	0 to +75	20	.005	1N938	6.7	0 to +75	20	.001	1N940	1.4	0 to +75	20	.002			
1N936A	70	-55 to +100	20	.005	1N938A	14	-55 to +100	20	.001	1N940A	1.8	-55 to +100	20	.002	1N936B	92	-55 to +150	20	.005	1N938B	19	-55 to +150	20	.001	1N940B	3.7	-55 to +150	20	.0002			
500 mW, V_Z 11.7 V $\pm 5\%$ (I_Z 7.5 mA) CASE 1 GLASS																																
1N941	88	0 to +75	30	.01	1N943	18	0 to +75	30	.002	1N945	4.4	0 to +75	30	.0005	1N941A	181	-55 to +100	30	.01	1N943A	36	-55 to +100	30	.002	1N945A	9.0	-55 to +100	30	.0005			
1N941B	240	-55 to +150	30	.01	1N943B	48	-55 to +150	30	.002	1N945B	12.0	-55 to +150	30	.0005	1N942	44	0 to +75	30	.005	1N944	8.8	0 to +75	30	.001	1N946	1.8	0 to +75	30	.002			
1N942A	91	-55 to +100	30	.005	1N944A	18	-55 to +100	30	.001	1N946A	3.6	-55 to +100	30	.002	1N942B	120	-55 to +150	30	.005	1N944B	24	-55 to +150	30	.001	1N946B	4.7	-55 to +150	30	.0002			
400 mW, V_Z 12.8 V $\pm 5\%$ (I_Z 0.5 mA) Maximum Noise Density (@ I_Z) is 0.8 $\mu V/\sqrt{Hz}$, CASE 1 GLASS																																
1N4896	96	+25 to +100	400	.01	1N4897A	99	-55 to +100	400	.005	1N4899	10	+25 to +100	400	.001	1N4896A	198	-55 to +100	400	.01	1N4898	19	+25 to +100	400	.002	1N4899A	20	-55 to +100	400	.001			
1N4897	48	+25 to +100	400	.005	1N4898A	40	-55 to +100	400	.002																							
400 mW, V_Z 12.8 V $\pm 5\%$ (I_Z 1.0 mA) Maximum Noise Density (@ I_Z) is 0.4 $\mu V/\sqrt{Hz}$, CASE 1 GLASS																																
1N4900	96	+25 to +100	200	.01	1N4901A	99	-55 to +100	200	.005	1N4903	10	+25 to +100	200	.001	1N4900A	198	-55 to +100	200	.01	1N4902	19	+25 to +100	200	.002	1N4903A	20	-55 to +100	200	.001			
1N4901	48	+25 to +100	200	.005	1N4902A	40	-55 to +100	200	.002																							
400 mW, V_Z 12.8 V $\pm 5\%$ (I_Z 2.0 mA) Maximum Noise Density (@ I_Z) is 0.25 $\mu V/\sqrt{Hz}$, CASE 1 GLASS																																
1N4904	96	+25 to +100	100	.01	1N4905A	99	-55 to +100	100	.005	1N4907	10	+25 to +100	100	.001	1N4904A	198	-55 to +100	100	.01	1N4906	19	+25 to +100	100	.002	1N4907A	20	-55 to +100	100	.001			
1N4905	48	+25 to +100	100	.005	1N4906A	40	-55 to +100	100	.002																							
400 mW, V_Z 12.8 V $\pm 5\%$ (I_Z 4.0 mA) Maximum Noise Density (@ I_Z) is 0.22 $\mu V/\sqrt{Hz}$, CASE 1 GLASS																																
1N4908	96	+25 to +100	50	.01	1N4909A	99	-55 to +100	50	.005	1N4911	10	+25 to +100	50	.001	1N4908A	198	-55 to +100	50	.01	1N4910	19	+25 to +100	50	.002	1N4911A	20	-55 to +100	50	.001			
1N4909	48	+25 to +100	50	.005	1N4910A	40	-55 to +100	50	.002																							
400 mW, V_Z 12.8 V $\pm 5\%$ (I_Z 7.5 mA) Maximum Noise Density (@ I_Z) is 0.20 $\mu V/\sqrt{Hz}$, CASE 1 GLASS																																
1N4912	96	+25 to +100	25	.01	1N4913A	99	-55 to +100	25	.005	1N4915	10	+25 to +100	25	.001	1N4912A	198	-55 to +100	25	.01	1N4914	19	+25 to +100	25	.002	1N4915A	20	-55 to +100	25	.001			
1N4913	48	+25 to +100	25	.005	1N4914A	40	-55 to +100	25	.002																							
400 mW, V_Z 19.2 V $\pm 5\%$ (I_Z 0.5 mA) Maximum Noise Density (@ I_Z) is 1.0 $\mu V/\sqrt{Hz}$, CASE 1 GLASS																																
1N4916	144	+25 to +100	600	.01	1N4917	72	+25 to +100	600	.005	1N4918	29	+25 to +100	600	.002	1N4916A	298	-55 to +100	600	.01	1N4917A	149	-55 to +100	600	.005	1N4918A	60	-55 to +100	600	.002			
400 mW, V_Z 19.2 V $\pm 5\%$ (I_Z 1.0 mA) Maximum Noise Density (@ I_Z) is 0.5 $\mu V/\sqrt{Hz}$, CASE 1 GLASS																																
1N4919	144	+25 to +100	300	.01	1N4920	72	+25 to +100	300	.005	1N4921	29	+25 to +100	300	.002	1N4919A	298	-55 to +100	300	.01	1N4920A	149	-55 to +100	300	.005	1N4921A	60	-55 to +100	300	.002			
400 mW, V_Z 19.2 V $\pm 5\%$ (I_Z 2.0 mA) Maximum Noise Density (@ I_Z) is 0.25 $\mu V/\sqrt{Hz}$, CASE 1 GLASS																																
1N4922	144	+25 to +100	150	.01	1N4923	72	+25 to +100	150	.005	1N4924	29	+25 to +100	150	.002	1N4922A	298	-55 to +100	150	.01	1N4923A	149	-55 to +100	150	.005	1N4924A	60	-55 to +100	150	.002			
400 mW, V_Z 19.2 V $\pm 5\%$ (I_Z 4.0 mA) Maximum Noise Density (@ I_Z) is 0.22 $\mu V/\sqrt{Hz}$, CASE 1 GLASS																																
1N4925	144	+25 to +100	75	.01	1N4926A	149	-55 to +100	75	.005	1N4928	14	+25 to +100	75	.001	1N4925A	298	-55 to +100	75	.01	1N4927	29	+25 to +100	75	.002	1N4928A	30	-55 to +100	75	.001			
1N4926	72	+25 to +100	75	.005	1N4927A	60	-55 to +100	75	.002																							
400 mW, V_Z 19.2 $\pm 5\%$ (I_Z 7.5 mA) Maximum Noise Density (@ I_Z) is 0.20 $\mu V/\sqrt{Hz}$, CASE 1 GLASS																																
1N4929	144	+25 to +100	36	.01	1N4930A	149	-55 to +100	36	.005	1N4932	14	+25 to +100	36	.001	1N4929A	298	-55 to +100	36	.01	1N4931	29	+25 to +100	36	.002	1N4932A	30	-55 to +100	36	.001			
1N4930	72	+25 to +100	36	.005	1N4931A	60	-55 to +100	36	.002																							
750 mW, V_Z 9.0 V to 9.8 V (I_Z 10 mA) CASE 2 METAL "A" suffix denotes $V_Z = 9.2$ to 9.6 Volts for 1N2163 thru 1N2171																																
1N2163	33	0 to +70	15	.005	1N2166	6.3	0 to +70	15	.001	1N2169	3.3	0 to +70	15	.0005	1N2163A	33	0 to +70	15	.005	1N2166A	6.3	0 to +70	15	.001	1N2169A	3.3	0 to +70	15	.0005			
1N2164	85	-55 to +125	15	.005	1N2167	17	-55 to +125	15	.001	1N2170	8.5	-55 to +125	15	.0005	1N2164A	85	-55 to +125	15	.005	1N2167A	17	-55 to +125	15	.001	1N2170A	8.5	-55 to +125	15	.0005			
1N2165	113	-55 to +185	15	.005	1N2168	23	-55 to +185	15	.001	1N2171	12	-55 to +185	15	.0005	1N2165A	113	-55 to +185	15	.005	1N2168A	23	-55 to +185	15	.001	1N2171A	12	-55 to +185	15	.0005			
750 mW, V_Z 9.3 V $\pm 5\%$ (I_Z 10 mA) CASE 2 METAL																																
1N2620	70	0 to +75	15	.01	1N2621B	95	-55 to +150	15	.005	1N2623A	15.0	-55 to +150	15	.001	1N2620A	144	-55 to +100	15	.01	1N2622	14	0 to +75	15	.002	1N2623B	20.0	-55 to +150	15	.001			
1N2620B	190	-55 to +150	15	.01	1N2622A	29	-55 to +100	15	.002	1N2624	3.5	0 to +75	15	.0005	1N2621	35	0 to +75	15	.005	1N2622B	39	-55 to +150	15	.002	1N2624A	7.5	-55 to +100	15	.0005			
1N2621A	72	-55 to +100	15	.005	1N2623	7	0 to +75	15	.001	1N2624B	9.2	-55 to +150	15	.0005																		
750 mW, V_Z 11.7 $\pm 5\%$ (I_Z 7.5 mA) CASE 2 METAL																																
1N3580	88	0 to 75	25	.01	1N3581B	120.0	-55 to +150	25	.005	1N3583A	19.0	-55 to +100	25	.001	1N3580A	182	-55 to +100	25	.01	1N3582B	18.0	0 to +75	25	.002	1N3583B	24.0	-55 to +150	25	.001			
1N3580B	240	-55 to +150	25	.01	1N3582	36.0	-55 to +100	25	.002	1N3584	4.4	0 to +75	25	.0005	1N3581A	44	0 to +75	25	.005	1N3582A	48.0	-55 to +150	25	.002	1N3584A	9.1	-55 to +100	25	.0005			
1N3581A	91	-55 to +100	25	.005	1N3583	8.8	0 to +75	25	.001	1N3584B	12.0	-55 to +150	25	.0005																		

MOULDED CASE TEMPERATURE COMPENSATED REFERENCE DIODES

ΔV_{ZT} specified over a Temperature Range of -55 to +100°C — Case Size Varies with Voltage

TYPE	$V_Z @ I_{ZT}$		ΔV_{ZT} Max. mV	Maximum Dynamic Impedance Ohms	Effective Temperature Coefficient %/°C	TYPE	$V_Z @ I_{ZT}$		ΔV_{ZT} Max. mV	Maximum Dynamic Impedance Ohms	Effective Temperature Coefficient %/°C	TYPE	$V_Z @ I_{ZT}$		ΔV_{ZT} Max. mV	Maximum Dynamic Impedance Ohms	Effective Temperature Coefficient %/°C
	Volts	mA					Volts	mA					Volts	mA			
1N1735	6.2	7.5	96	20	.01	1N1740	37.2	7.5	476	120	.01	1N2766A	13.6	7.5	52	40	.0025
1N1736	12.4	7.5	192	40	.01	1N1740A	37.2	7.5	288	120	.005	1N2767	20.4	7.5	155	60	.005
1N1736A	12.4	7.5	96	40	.005	1N1741	43.4	7.5	672	140	.01	1N2767A	20.4	7.5	78	60	.0025
1N1737	18.6	7.5	288	60	.01	1N1741A	43.4	7.5	336	140	.005	1N2768	27.2	7.5	206	80	.005
1N1737A	18.6	7.5	144	60	.005	1N1742	49.6	7.5	768	160	.01	1N2768A	27.2	7.5	103	80	.0025
1N1738	24.8	7.5	384	80	.01	1N1742A	49.6	7.5	384	160	.005	1N2769	34.0	7.5	259	100	.005
1N1738A	24.8	7.5	192	80	.005	1N2765A	6.8	7.5	51	20	.005	1N2769A	34.0	7.5	130	100	.0025
1N1739	31.0	7.5	480	100	.01	1N2765A	6.8	7.5	27	20	.0025	1N2770	40.8	7.5	310	120	.005
1N1739A	31.0	7.5															

HIGH VOLTAGE RECTIFIERS — MOULDED CASE

CUSTOM RECTIFIERS available with voltage ratings up to 150,000 volts

TYPE	Peak Inverse Voltage (PIV) Volts	Maximum Forward Output Current @ 75°C I _o mA	Forward Surge Current @ 35°C I _{fs} Amps	Maximum Reverse Current @ 25°C @ PIV IR μA DC	TYPE	Peak Inverse Voltage (PIV) Volts	Maximum Forward Output Current I _o mA	Forward Surge Current I _{fs} Amps	Maximum Reverse Current @ 25°C @ PIV IR μA DC	TYPE	Peak Inverse Voltage (PIV) Volts	Forward Surge Current I _{fs} Amps	Maximum Forward Output Current I _o mA	Maximum Reverse Current @ 25°C @ PIV IR μA DC
CASE 9 length varies with PIV														
1N1133	1,500	75	6	25	1N2384	8,000	70	6.0	10	DER11	11,000	30	130	2
1N1134	1,500	100	6	25	1N2385	10,000	70	6.0	10	CASE 12				
1N1135	1,800	65	6	25	1N2374	1,000	250	12	1	DER12	12,000	20	125	2
1N1136	1,800	85	6	25	1N2375	1,500	200	12	1	DER13	13,000	20	125	2
1N1137	2,400	50	6	25	1N2376	2,000	200	12	1	DER14	14,000	20	125	2
1N1138	2,400	60	6	25	1N2377	2,400	150	12	1	DER15	15,000	20	120	2
1N1139	3,600	65	6	25	1N2378	3,000	150	12	1	CASE 10				
1N1140	3,600	65	6	25	1N2379	4,000	100	12	1	DICR1	1,000	20	600	2
1N1141	4,800	60	6	25	1N2380	6,000	100	12	1	DICR2	2,000	15	350	2
1N1142	4,800	50	6	25	1N2381	10,000	75	12	1	DICR3	3,000	15	250	2
1N1143	6,000	50	6	25	CASE 10					DICR4	4,000	10	190	2
1N1143A	6,000	65	6	25	CASE 10					DICR5	5,000	10	170	2
Case sizes vary with type														
1N1730	1,000	200	2.5	10	CASE 10					DICR6	6,000	10	150	2
1N1731	1,500	200	2.5	10	CASE 10					CASE 11				
1N1732	2,000	200	2.5	10	DER1	1,000	1,000	40	2	DICR7	7,000	10	130	2
1N1733	3,000	150	2.5	10	DER2	2,000	500	40	2	DICR8	8,000	10	110	2
1N1734	5,000	100	2.5	10	DER3	3,000	400	40	2	DICR9	9,000	10	100	2
1N2382	4,000	150	6.0	10	DER4	4,000	300	40	2	DICR10	10,000	10	90	2
1N2383	6,000	100	6.0	10	DER5	5,000	200	40	2	DICR11	11,000	10	80	2
CASE 11														
1N1732	2,000	200	2.5	10	DER6	6,000	200	40	2	DICR12	12,000	10	75	2
1N1733	3,000	150	2.5	10	DER7	7,000	200	30	2	DICR13	13,000	10	70	2
1N1734	5,000	100	2.5	10	DER8	8,000	175	30	2	DICR14	14,000	10	65	2
1N2382	4,000	150	6.0	10	DER9	9,000	150	30	2	DICR15	15,000	10	60	2
1N2383	6,000	100	6.0	10	DER10	10,000	140	30	2					

FAST RECOVERY RECTIFIERS $t_{rr} = 0.2 \mu\text{sec}$ max 1, 6, 12 Amp types

CASE 4				CASE 13				
TYPE	100°C	100°C	100°C	TYPE	75°C	75°C	TYPE	
1N3879	50	6	75	1N3889	50	12	1N4933	50
1N3880	100	6	75	1N3890	100	12	1N4934	100
1N3881	200	6	75	1N3891	200	12	1N4935	200
1N3882	300	6	75	1N3892	300	12	1N4936	400
1N3883	400	6	75	1N3893	400	12	1N4937	600

SILICON TUNNEL DIODES

Recently added to the Dickson product line these devices feature standard I_p tolerances as low as 2% in conjunction with intrinsic qualities of high V_F to V_P ratio, and wide operating and storage temperature range.

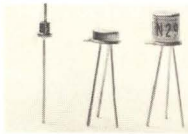

Type	Peak Point Current		Maximum Valley Point Current	Maximum Peak Point Voltage	Maximum Valley Point Voltage	Forward Voltage @ Applied Current			Total Series Resistance	Valley Point Terminal Capacitance Freq. — 5 MC
	I _p					V _F @ I _r		R _s		
	mA		mV	mV	mV	Ohms	pf			
1N2927	.09	.11	.035	75	475	600	1000	.11	10.0	80
1N2927A	.098	.102	.030	70	450	650	1000	.102	10.0	80
1N2928	.42	.52	.170	80	490	670	1000	.52	3.0	100
1N2928A	.46	.48	.145	74	470	710	1000	.145	3.0	100
1N2929	.90	1.10	.350	80	500	700	1000	1.10	2.0	150
1N2929A	.93	1.02	.300	75	475	730	1000	1.02	2.0	150
1N2930	4.23	5.17	1.70	85	520	740	1000	5.17	1.0	250
1N2930A	4.61	4.79	1.45	79	495	750	1000	4.79	1.0	250
1N2931	9.0	11.0	3.50	85	530	740	1000	11.0	1.0	400
1N2931A	9.6	10.2	3.0	80	500	750	1000	10.2	1.0	400
1N2932	19.8	24.2	8.0	90	530	740	1000	24.2	0.8	1200
1N2932A	21.56	22.44	6.5	82	500	750	1000	22.44	0.8	1200
1N2933	42.3	51.7	17.0	90	530	740	1000	51.7	0.6	1800
1N2933A	46.06	47.94	14.5	83	500	750	1000	47.94	0.6	1800
1N2934	90.0	110.0	35.0	90	530	720	1000	110.0	0.5	2500
1N2934A	98.0	102.0	30.0	85	500	730	1000	102.0	0.5	2500

POSITIVE TEMPERATURE COEFFICIENT SILICON RESISTORS

Available in values of 10 Ω thru 2.2 ΩK, 1/8 and 1/4 watt packages. This latest addition to Dickson's product line is characterized by a large controlled positive temperature coefficient of resistance.

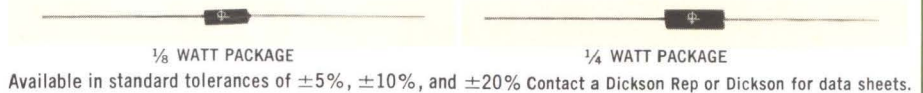

1/8 WATT, +0.7% / °C Temperature Coefficient						1/4 WATT, +0.7% / °C Temperature Coefficient					
TYPE	Resistance Ohms	TYPE	Resistance Ohms	TYPE	Resistance Ohms	TYPE	Resistance Ohms	TYPE	Resistance Ohms	TYPE	Resistance Ohms
S100	10	S47D	47	S220D	220	S1K	1K	S100	10	S47D	47
S12D	12	S56D	56	S270D	270	S1.2K	1.2K	S12D	12	S56D	56
S15D	15	S68D	68	S330D	330	S1.5K	1.5K	S15D	15	S68D	68
S18D	18	S82D	82	S390D	390	S1.8K	1.8K	S18D	18	S82D	82
S22D	22	S100D	100	S470D	470	S2.2K	2.2K	S22D	22	S100D	100
S27D	27	S120D	120	S560D	560	S27D	27	S120D	120	S560D	560
S33D	33	S150D	150	S680D	680	S33D	33	S150D	150	S680D	680
S39D	39	S180D	180	S820D	820	S39D	39	S180D	180	S820D	820



SILICON DIFFUSED MULTI-TAP RESISTORS

Especially applicable to hybrid circuits requiring precision resistance values, and low temperature coefficient. These devices incorporate 12 sections with resistance values ranging from 1000-2500 Ω, and 12 with resistance values ranging from 100-250 Ω, allowing user to probe and bond to obtain highly accurate resistance.

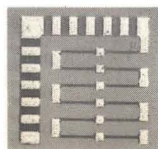

FEATURES:

- ♦ Easily soldered into circuits.
- ♣ Aluminum pads for conventional bonding.
- ♥ Similarity of characteristics to monolithic resistors allows easy conversion to monolithic circuits.

Contact a Dickson Rep or Dickson for data sheets.

FIELD EFFECT TRANSISTORS

Covering a transconductance range from 200 μ mhos to 10,000 μ mhos, Dickson field effect transistors are available in both N and P channel configurations. Applications include: low-noise voltage amplifiers, voltage-variable resistors, and many other applications.

FEATURES:

- ♠ High input resistance
- ♦ Low-noise
- ♣ Low harmonic distortion
- ♥ Low-current drain
- ♠ High-gain
- ♥ Low-leakage currents

TYPE	BV _{DGO} (Volts)	I _{ESS} (nA)	I _{DSS} (mA)		V _P (Volts)	g _{fs} (μ mho)		NF
			Min	Max		Min	Max	
N-CHANNEL								
D1101	25	-10	0.8	4	-10	400	2000	3db
D1102	25	-10	0.2	1	-5	300	1000	3db
D1103	25	-10	0.05	0.25	-2.5	200	1000	3db
D1177	50	-5	0.8	4	-10	400	2000	3db
D1178	50	-5	0.2	1	-5	300	1000	3db
D1179	50	-5	0.05	0.25	-2.5	200	1000	3db
D1180	50	-5	2	10	-10	1000	4000	3db
D1181	50	-5	0.5	2.5	-5	750	2500	3db
D1182	50	-5	0.1	0.6	-2.5	500	2500	3db
D1183	50	-5	3	15	-8	2500	10000	3db
D1184	50	-5	0.8	4	-4	1500	6000	3db
D1185	50	-5	0.2	1	-2	800	4500	3db
DN3066A	50	-1	0.8	4	-10	400	1000	0.1db (typ)
DN3067A	50	-1	0.2	1	-5	300	1000	
DN3068A	50	-1	0.05	0.25	-2.5	200	1000	

TYPE	BV _{DGO} (Volts)	I _{ESS} (nA)	I _{DSS} (mA)		V _P (Volts)	g _{fs} (μ mho)		NF
			Min	Max		Min	Max	
DN3069A	50	-1	2	10	-10	1000	2500	0.1db (typ)
DN3070A	50	-1	0.5	2.5	-5	750	2500	
DN3071A	50	-1	0.1	0.6	-2.5	500	2500	
2N3066	50	-1	0.8	4	-10	400	1000	3db
2N3067	50	-1	0.2	1	-5	300	1000	3db
2N3068	50	-1	0.05	0.25	-2.5	200	1000	3db
2N3069	50	-1	2	10	-10	1000	2500	3db
2N3070	50	-1	0.5	2.5	-5	750	2500	3db
2N3071	50	-1	0.1	0.6	-2.5	500	2500	3db
2N3085	40	-0.1	0.8	3	-10	400	1200	2db
2N3087	40	-1	0.8	3	-10	400	1200	2db
2N3089	40	-1	0.5	2	-5	300	900	0.5db
2N3089A	40	-1	0.5	2	-5	300	900	0.1db
2N3368	40	-5	2	12	-12	1000	4000	3db
2N3369	40	-5	0.5	2.5	-7	600	2500	3db
2N3370	40	-5	0.1	0.6	-3.5	300	2500	3db

P-CHANNEL								
2N2386	-20	10	1	-10	8	1000		3db
2N2606	-40	1	-0.1	-0.5	4	110		3db
2N2607	-40	3	-0.3	-1.5	4	330		3db

2N2841	-40	1	-25	-125	1.7	60	300	3db
2N2842	-40	3	-65	-325	1.7	180	500	3db

PHOTO FETS, N-CHANNEL								
TYPE	BV _{ESS} (Volts)	I _{ESS} (nA)	I _{DSS} (mA)		V _P (Volts)	g _{fs} (μ mho)		λ I _D (μ A/FC)
			Min	Max		Min	Max	
PFN3066	50	1	0.8	4	8	400	1000	12
PFN3069	50	1	2	10	8	1000	2500	14
PFN3458	50	1	3	15	8	2500	10,000	35

MATCHED PAIRS										
TYPE	BV _{DGO} (Volts)	I _{ESS} (nA)	I _{DSS} (mA)		V _P (Volts)	g _{fs} (μ mho)		V _{GS1} -V _{GS2} (mV)	$\Delta(V_{GS1}-V_{GS2})/\Delta T$	NF
			Min	Max		Min	Max			
DFNA3-50	50	0.5	0.35	2.5	4	750	2000	50	50 μ V/ $^{\circ}$ C	2db
DFNA3-100	50	0.5	0.35	2.5	4	750	2000	100	100 μ V/ $^{\circ}$ C	2db

REFERENCE AMPLIFIERS

Specifically designed for use in regulated power supplies, as combination voltage reference elements and error-voltage amplifiers, Dickson Reference Amplifiers provide temperature compensation for optimum reference voltage stability. Dickson's 6.8 volt series incorporates a NPN Tran-

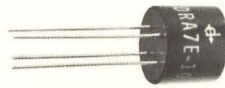

sistor and a silicon voltage regulator diode. Operating temperature range is -25° to 100° C. They are specified with a variety of reference voltage stability factors to permit selection of the most economical device to meet circuit requirements. Contact a Dickson Rep or Dickson for data sheets.

SOLID TANTALUM CAPACITORS

Seven polar, six non-polar series, plus two mil-spec types in a voltage range of 6-100 volts comprise the present product line. This table indicates product range only. For more detailed information fill out and mail the attached Business Reply card, or contact a Dickson representative or distributor.

COMMERCIAL TYPES — For top performance and reliability, Dickson combines devices of mil-spec construction to produce standard and custom designs in both polar and non-polar types.

Packaging and configurations includes:

- ♠ Miniature packages, hermetically sealed.
- ♥ Epoxy encapsulated packages.
- ♣ Base-offset rectangular packages.

MIL SPEC TYPES: CS12, CS13, MIL-C-26655/2D CSR13 MIL-C-39003

All capacitance ratings are available in tolerances of $\pm 5\%$, $\pm 10\%$ and $\pm 20\%$.

Case Code	Cap/Voltage Range		Dimensions	Notes
	Min/Max μ fd	Min/Max Volts		
A	.0047/6.8	6/100	Length .286 \pm .031 Dia. .135 \pm .016 -.015	Meets Mil 26655B/2D where applicable and Mil 39003 where applicable
B	.68/68	6/100	Length .474 \pm .031 Dia. .185 \pm .016 -.015	Meets Mil 26655B/2D where applicable and Mil 39003 where applicable
C	4.7/180	6/75	Length .686 \pm .031 Dia. .289 \pm .016 -.015	Meets Mil 26655B/2D where applicable and Mil 39003 where applicable
D	12/330	6/75	Length .786 \pm .031 Dia. .351 \pm .016 -.015	Meets Mil 26655B/2D where applicable and Mil 39003 where applicable
AE	.0047/6.8	6/100	Length .286 \pm .031 Dia. .135 \pm .016 -.015	Epoxy end-fill version of Item 1
BE	.68/68	6/100	Length .474 \pm .031 Dia. .185 \pm .016 -.015	Epoxy end-fill version of Item 2
CE	4.7/180	6/75	Length .686 \pm .031 Dia. .289 \pm .016 -.015	Epoxy end-fill version of Item 3

Case Code	Cap/Voltage Range		Dimensions	Notes
	Min/Max μ fd	Min/Max Volts		
DE	12/680	6/75	Length .786 \pm .031 Dia. .351 \pm .016 -.015	Epoxy end-fill version of Item 4
AN	.0023/3.4	6/100	Length .585 \pm .031 Dia. .160 \pm .010 -.015	Non-Polar version of Item 1
BN	.34/30	6/100	Length .935 \pm .031 Dia. .205 \pm .010 -.015	Non-Polar version of Item 2
CN	2.3/90	6/75	Length 1.360 \pm .031 Dia. .310 \pm .010 -.015	Non-Polar version of Item 3
DN	6.0/160	6/75	Length 1.600 \pm .031 Dia. .370 \pm .010 -.015	Non-Polar version of Item 4
T	.0047/6.8	4/100	Length .250 Dia. .091	Smallest hermetic sealed device in the industry
TA	.27/12	4/100	Length .265 Dia. .130	Same cap/voltage ratings as in Mil "A" case with no protruding eyelet

NOTE: Check with factory or factory representative for specific capacitance and voltage combinations.

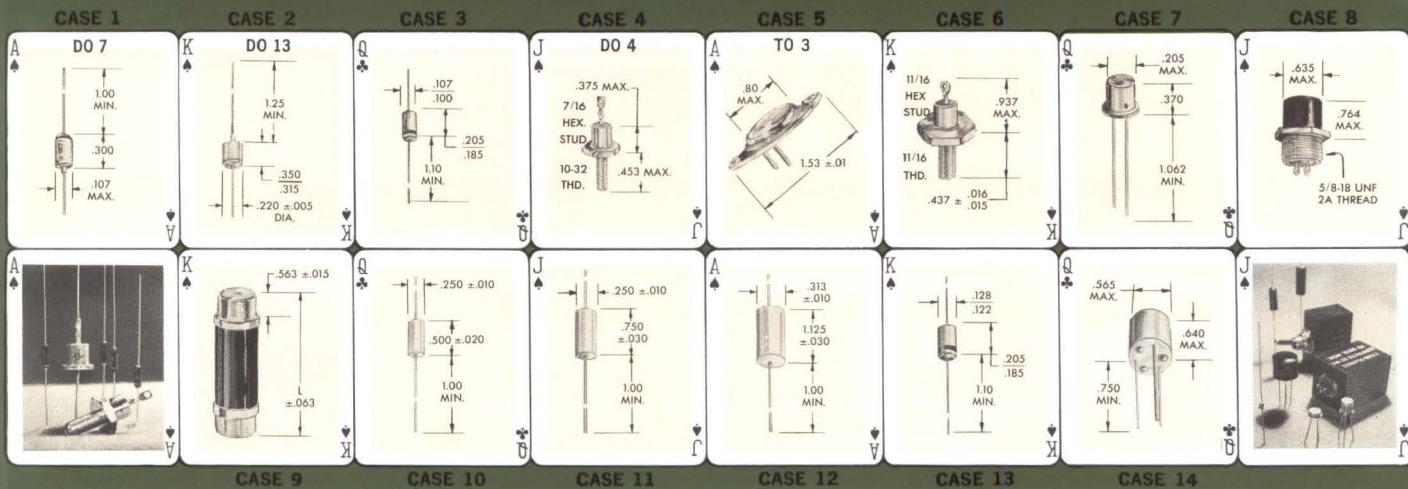

TYPE	Nominal Voltage $V_Z @ I_{ZT}$ Volts	Test Current I_{ZT} mA	Maximum Impedance $Z_{T1} @ I_{ZT}$ Ohms	TYPE	Nominal Voltage $V_Z @ I_{ZT}$ Volts	Test Current I_{ZT} mA	Maximum Impedance $Z_{T1} @ I_{ZT}$ Ohms	TYPE	Nominal Voltage $V_Z @ I_{ZT}$ Volts	Test Current I_{ZT} mA	Maximum Impedance $Z_{T1} @ I_{ZT}$ Ohms	TYPE	Nominal Voltage $V_Z @ I_{ZT}$ Volts	Test Current I_{ZT} mA	Maximum Impedance $Z_{T1} @ I_{ZT}$ Ohms
10 WATT — CASE 4 METAL															
1N2970*	6.8	370.0	1.2	1N2982*	18.0	140.0	4.0	1N2997*	51.0	50.0	15.0	1N3012	160.0	16.0	200.0
1N2971*	7.5	335.0	1.3	1N2984*	20.0	125.0	4.0	1N2999*	56.0	45.0	16.0	1N3014	180.0	14.0	260.0
1N2972*	8.2	305.0	1.5	1N2985*	22.0	115.0	5.0	1N3000*	62.0	40.0	17.0	1N3015	200.0	12.0	300.0
1N2973*	9.1	275.0	2.0	1N2986*	24.0	105.0	5.0	1N3001*	68.0	37.0	18.0	1N3993*	3.9	640.0	2.0
1N2974*	10.0	250.0	3.0	1N2988*	27.0	95.0	7.0	1N3003*	82.0	30.0	25.0	1N3994*	4.3	580.0	1.5
1N2975*	11.0	230.0	3.0	1N2989*	30.0	85.0	8.0	1N3004*	91.0	28.0	35.0	1N3995*	4.7	530.0	1.2
1N2976*	12.0	210.0	3.0	1N2990*	33.0	75.0	9.0	1N3005*	100.0	25.0	40.0	1N3996*	5.1	490.0	1.1
1N2977*	13.0	190.0	3.0	1N2991*	36.0	70.0	10.0	1N3007*	110.0	23.0	55.0	1N3997*	5.6	445.0	1.0
1N2978*	14.0	180.0	3.0	1N2992*	39.0	65.0	11.0	1N3008*	120.0	20.0	75.0	1N3998*	6.2	405.0	1.1
1N2979*	15.0	170.0	3.0	1N2993*	43.0	60.0	12.0	1N3009*	130.0	19.0	100.0	1N3999*	6.8	370.0	1.2
1N2980*	16.0	155.0	4.0	1N2995*	47.0	55.0	14.0	1N3011*	150.0	17.0	175.0	1N4000*	7.5	335.0	1.3

TYPE	TYPE	Nominal Voltage $V_Z @ I_{ZT}$ Volts	Test Current I_{ZT} mA	Maximum Zener Impedance $Z_{T1} @ I_{ZT}$ Ohms	TYPE	TYPE	Nominal Voltage $V_Z @ I_{ZT}$ Volts	Test Current I_{ZT} mA	Maximum Zener Impedance $Z_{T1} @ I_{ZT}$ Ohms
50 WATT — CASE 5 AND 6 METAL									
1N2804	1N3305	6.8	1850.0	0.2	1N2825*	1N3326	36.0	350.0	3.5
1N2805	1N3306	7.5	1700.0	0.3	1N2826*	1N3327	39.0	320.0	4.0
1N2806*	1N3307	8.2	1500.0	0.4	1N2827*	1N3328	43.0	290.0	4.5
1N2807*	1N3308	9.1	1370.0	0.5	1N2829*	1N3330	47.0	270.0	5.0
1N2808*	1N3309	10.0	1200.0	0.6	1N2831*	1N3332	51.0	245.0	5.2
1N2809*	1N3310	11.0	1100.0	0.8	1N2832*	1N3334	56.0	220.0	6.0
1N2810*	1N3311	12.0	1000.0	1.0	1N2833*	1N3335	62.0	200.0	7.0
1N2811*	1N3312	13.0	960.0	1.1	1N2834*	1N3336	68.0	180.0	8.0
1N2812*	1N3313	14.0	890.0	1.2	1N2836*	1N3338	82.0	150.0	11.0
1N2813*	1N3314	15.0	830.0	1.4	1N2837*	1N3339	91.0	140.0	15.0
1N2814*	1N3315	16.0	780.0	1.6	1N2838	1N3340	100.0	120.0	20.0
1N2816*	1N3317	18.0	700.0	2.0	1N2840	1N3342	110.0	110.0	30.0
1N2818*	1N3319	20.0	630.0	2.4	1N2841	1N3343	120.0	100.0	40.0
1N2819*	1N3320	22.0	570.0	2.5	1N2842	1N3344	130.0	95.0	50.0
1N2820*	1N3321	24.0	520.0	2.6	1N2843	1N3346	150.0	85.0	75.0
1N2822*	1N3323	27.0	460.0	2.8	1N2844	1N3347	160.0	80.0	80.0
1N2823*	1N3324	30.0	420.0	3.0	1N2845	1N3349	180.0	68.0	90.0
1N2824*	1N3325	33.0	380.0	3.2	1N2846	1N3350	200.0	65.0	100.0

TEMPERATURE COMPENSATED REFERENCE DIODES

TYPE	ΔV_{ZT} Max. mV	Temp. over Range °C	Maximum Dynamic Impedance Ohms	Effective Temperature Coefficient %/°C	TYPE	ΔV_{ZT} Max. mV	Temp. over Range °C	Maximum Dynamic Impedance Ohms	Effective Temperature Coefficient %/°C	TYPE	ΔV_{ZT} Max. mV	Temp. over Range °C	Maximum Dynamic Impedance Ohms	Effective Temperature Coefficient %/°C
200 mW, V_Z 6.2 V $\pm 5\%$ (I_Z 7.5 mA) CASE 7														
1N429*	96	-55 to +100	20	.01	1N430	26	-55 to +100	15	.002	250 mW, V_Z 8.4 V $\pm 5\%$ (I_Z 10 mA) CASE 8 MOULDED CAP				
250 mW, V_Z 8.4 V $\pm 5\%$ (I_Z 10 mA) CASE 14 MOULDED														
1N1530	26	-55 to +100	15	.002	1N1530*	13	-55 to +100	15	.001	400 mW, V_Z 6.2 V $\pm 5\%$ (I_Z 7.5 mA) CASE 1 GLASS				
1N821*	96	-55 to +100	15	.01	1N823A*	48	-55 to +100	10	.005	1N827*	9.6	-55 to +100	15	.001
1N821A*	96	-55 to +100	10	.01	1N825*	19	-55 to +100	15	.002	1N827A*	9.6	-55 to +100	10	.001
1N823*	48	-55 to +100	15	.005	1N825A*	19	-55 to +100	10	.002	1N829*	4.6	-50 to +100	15	.0005
400 mW, V_Z 6.4 V $\pm 5\%$ (I_Z 0.5 mA) CASE 1 GLASS														
1N4565	48	0 to +75	200	.01	1N4567	9.6	0 to +75	200	.002	1N4569	2.4	0 to +75	200	.0005
1N4565A	99	-55 to +100	200	.01	1N4567A	20	-55 to +100	200	.002	1N4569A	5.0	-55 to +100	200	.0005
1N4566	24	0 to +75	200	.005	1N4568	4.8	0 to +75	200	.001					
1N4566A	50	-55 to +100	200	.005	1N4568A	9.9	-55 to +100	200	.001					
400 mW, V_Z 6.4 V $\pm 5\%$ (I_Z 1.0 mA) CASE 1 GLASS														
1N4570	48	0 to +75	100	.01	1N4572	9.6	0 to +75	100	.002	1N4574	2.4	0 to +75	100	.0005
1N4570A	99	-55 to +100	100	.01	1N4572A	20	-55 to +100	100	.002	1N4574A	5.0	-55 to +100	100	.0005
1N4571	24	0 to +75	100	.005	1N4573	4.8	0 to +75	100	.001					
1N4571A	50	-55 to +100	100	.005	1N4573A	9.9	-55 to +100	100	.001					
400 mW, V_Z 6.4 V $\pm 5\%$ (I_Z 2.0 mA) CASE 1 GLASS														
1N4575	48	0 to +75	50	.01	1N4577	9.6	0 to +75	50	.002	1N4579	2.4	0 to +75	50	.0005
1N4575A	99	-55 to +100	50	.01	1N4577A	20	-55 to +100	50	.002	1N4579A	5.0	-55 to +100	50	.0005
1N4576	24	0 to +75	50	.005	1N4578	4.8	0 to +75	50	.001					
1N4576A	50	-55 to +100	50	.005	1N4578A	9.9	-55 to +100	50	.001					
400 mW, V_Z 6.4 V $\pm 5\%$ (I_Z 4.0 mA) CASE 1 GLASS														
1N4580	48	0 to +75	25	.01	1N4582	9.6	0 to +75	25	.002	1N4584	2.4	0 to +75	25	.0005
1N4580A	99	-55 to +100	25	.01	1N4582A	20	-55 to +100	25	.002	1N4584A	5.0	-55 to +100	25	.0005
1N4581	24	0 to +75	25	.005	1N4583	4.8	0 to +75	25	.001					
1N4581A	50	-55 to +100	25	.005	1N4583A	9.9	-55 to +100	25	.001					

* MIL devices



IN JUST SIX YEARS . . .

Dickson has become a major supplier of high-reliability semiconductors to the Aerospace, Military, Industrial and Consumer markets. In these competitive markets of super critical technical requirements where the criterion for value is product performance, Dickson product sales have almost doubled every year for five years.

Dickson's rapid growth to prominence as a prime source for high-reliability zener diodes, high voltage rectifiers, and tantalum capacitors has been earned by providing the customer with specific benefits:

- ♠ Maximum value, based on product performance. ♥ Practical application of technical skill to customer design problems.

- ♣ More JEDEC registered T.C. reference diodes than all other suppliers combined.

Dickson zener diodes, rectifiers, and tantalum capacitors are now used in critical applications on most of our nation's missile and aerospace hardware including, NIKE X, GEMINI, TITAN II, III, RANGER, MARINER, POLARIS and TFX (F-111). The product lines have been expanded to include special related products, manufactured to provide the same customer benefits:

- ♠ Field Effect Transistors ♥ Reference Amplifiers ♣ Solid-State Circuit Breakers ♦ Time Delay Relays ♠ Silicon Tunnel Diodes ♥ Silicon Resistors

The devices shown in the listings here are the more popular types and represent only a small portion of those available from Dickson.

ZENER DIODES available in standard voltage tolerances of ±5%, ±10%, ±20%

TYPE	Nominal Voltage V _Z @ I _{ZT} Volts	Test Current I _{ZT} mA	Maximum Impedance Z _{ZT} @ I _{ZT} Ohms	TYPE	Nominal Voltage V _Z @ I _{ZT} Volts	Test Current I _{ZT} mA	Maximum Impedance Z _{ZT} @ I _{ZT} Ohms	TYPE	Nominal Voltage V _Z @ I _{ZT} Volts	Test Current I _{ZT} mA	Maximum Impedance Z _{ZT} @ I _{ZT} Ohms	TYPE	Nominal Voltage V _Z @ I _{ZT} Volts	Test Current I _{ZT} mA	Maximum Impedance Z _{ZT} @ I _{ZT} Ohms
250 mW — CASE 1 GLASS															
1L22.2D	2.2	10	60	1Z6.8D	6.8	9.2	7.0	1Z22D	22	2.8	40	1Z75D	75	0.83	450
1L22.4D	2.4	10	60	1Z7.5D	7.5	8.3	8.0	1Z24D	24	2.6	46	1Z82D	82	0.76	550
1L22.7D	2.7	10	60	1Z8.2D	8.2	7.6	9.0	1Z27D	27	2.3	58	1Z91D	91	0.69	700
1L23.0D	3.0	10	55	1Z9.1D	9.1	6.9	10	1Z30D	30	2.1	70	1Z100D	100	0.63	900
1L23.3D	3.3	10	55	1Z10D	10	6.3	11	1Z33D	33	1.9	85	1Z110D	110	0.57	1200
1L23.6D	3.6	10	50	1Z11D	11	5.7	13	1Z36D	36	1.7	100	1Z120D	120	0.52	1500
1L23.9D	3.9	10	50	1Z12D	12	5.2	15	1Z39D	39	1.6	120	1Z130D	130	0.48	1900
1L24.3D	4.3	10	45	1Z13D	13	4.8	18	1Z43D	43	1.5	140	1Z150D	150	0.42	2500
1L24.7D	4.7	10	35	1Z14D	14	4.5	20	1Z47D	47	1.3	160	1Z160D	160	0.40	2800
1L25.1D	5.1	10	25	1Z15D	15	4.2	22	1Z51D	51	1.2	190	1Z180D	180	0.35	3500
1L25.6D	5.6	10	20	1Z16D	16	3.9	24	1Z56D	56	1.1	230	1Z200D	200	0.31	4300
1L26.2D	6.2	10	15	1Z18D	18	3.5	28	1Z62D	62	1.0	290				
1L26.8D	6.8	10	10	1Z20D	20	3.1	33	1Z68D	68	0.92	350				
400 mW — CASE 1 GLASS															
1N4370*	2.4	20.0	30.0	1N757*	9.1	20.0	10.0	1N968*	20.0	6.2	25.0	1N982*	75.0	1.7	270.0
1N4371*	2.7	20.0	30.0	1N758*	10.0	20.0	17.0	1N969*	22.0	5.6	29.0	1N983*	82.0	1.5	330.0
1N4372*	3.0	20.0	29.0	1N759*	12.0	20.0	30.0	1N970*	24.0	5.2	33.0	1N984*	91.0	1.4	400.0
1N746*	3.3	20.0	28.0	1N957*	6.8	18.5	4.5	1N971*	27.0	4.6	41.0	1N985*	100.0	1.3	500.0
1N747*	3.6	20.0	24.0	1N958*	7.5	16.5	5.5	1N972*	30.0	4.2	49.0	1N986*	110.0	1.1	750.0
1N748*	3.9	20.0	23.0	1N959*	8.2	15.0	6.5	1N973*	33.0	3.8	58.0	1N987*	120.0	1.0	900.0
1N749*	4.3	20.0	22.0	1N960*	9.1	14.0	7.5	1N974*	36.0	3.4	70.0	1N988*	130.0	0.95	1100.0
1N750*	4.7	20.0	19.0	1N961*	10.0	12.5	8.5	1N975*	39.0	3.2	80.0	1N989*	150.0	0.85	1500.0
1N751*	5.1	20.0	17.0	1N962*	11.0	11.5	9.5	1N976*	43.0	3.0	93.0	1N990*	160.0	0.80	1700.0
1N752*	5.6	20.0	11.0	1N963*	12.0	10.5	11.5	1N977*	47.0	2.7	105.0	1N991*	180.0	0.68	2200.0
1N753*	6.2	20.0	7.0	1N964*	13.0	9.5	13.0	1N978*	51.0	2.5	125.0	1N992*	200.0	0.65	2500.0
1N754*	6.8	20.0	5.0	1N965*	15.0	8.5	16.0	1N979*	56.0	2.2	150.0				
1N755*	7.5	20.0	6.0	1N966*	16.0	7.8	17.0	1N980*	62.0	2.0	185.0				
1N756*	8.2	20.0	8.0	1N967*	18.0	7.0	21.0	1N981*	68.0	1.8	230.0				
400 mW — CASE 1 GLASS Max. Noise Density (@ I _{ZT}) is 40 μVrms/√Hz, Featuring Low Leakage															
1N4099	6.8	0.25	200.0	1N4105	11.0	0.25	200.0	1N4111	17.0	0.25	100.0	1N4117	25.0	0.25	150.0
1N4100	7.5	0.25	200.0	1N4106	12.0	0.25	200.0	1N4112	18.0	0.25	100.0	1N4118	27.0	0.25	150.0
1N4101	8.2	0.25	200.0	1N4107	13.0	0.25	200.0	1N4113	19.0	0.25	150.0	1N4119	28.0	0.25	200.0
1N4102	8.7	0.25	200.0	1N4108	14.0	0.25	200.0	1N4114	20.0	0.25	150.0	1N4120	30.0	0.25	200.0
1N4103	9.1	0.25	200.0	1N4109	15.0	0.25	100.0	1N4115	22.0	0.25	150.0	1N4121	33.0	0.25	200.0
1N4104	10.0	0.25	200.0	1N4110	16.0	0.25	100.0	1N4116	24.0	0.25	150.0				
1 WATT — CASE 2 METAL															
1N3016*	6.8	37.0	3.5	1N3028*	22.0	11.5	23.0	1N3040*	68.0	3.7	150.0	1N3821*	3.3	76.0	10.0
1N3017*	7.5	34.0	4.0	1N3029*	24.0	10.5	25.0	1N3041*	75.0	3.3	175.0	1N3822*	3.6	69.0	10.0
1N3018*	8.2	31.0	4.5	1N3030*	27.0	9.5	35.0	1N3042*	82.0	3.0	200.0	1N3823*	3.9	64.0	9.0
1N3019*	9.1	28.0	5.0	1N3031*	30.0	8.5	40.0	1N3043*	91.0	2.8	250.0	1N3824*	4.3	58.0	9.0
1N3020*	10.0	25.0	7.0	1N3032*	33.0	7.5	45.0	1N3044*	100.0	2.5	350.0	1N3825*	4.7	53.0	8.0
1N3021*	11.0	23.0	8.0	1N3033*	36.0	7.0	50.0	1N3045*	110.0	2.3	450.0	1N3826*	5.1	49.0	7.0
1N3022*	12.0	21.0	9.0	1N3034*	39.0	6.5	60.0	1N3046*	120.0	2.0	550.0	1N3827*	5.6	45.0	5.0
1N3023*	13.0	19.0	10.0	1N3035*	43.0	6.0	70.0	1N3047*	130.0	1.9	700.0	1N3828*	6.2	41.0	2.0
1N3024*	15.0	17.0	14.0	1N3036*	47.0	5.5	80.0	1N3048*	150.0	1.7	1000.0	1N3829*	6.8	37.0	1.5
1N3025*	16.0	15.5	16.0	1N3037*	51.0	5.0	95.0	1N3049*	160.0	1.6	1100.0	1N3830*	7.5	34.0	1.5
1N3026*	18.0	14.0	20.0	1N3038*	56.0	4.5	110.0	1N3050*	180.0	1.4	1200.0				
1N3027*	20.0	12.5	22.0	1N3039*	62.0	4.0	125.0	1N3051*	200.0	1.2	1500.0				
1 WATT — CASE 3 MOULDED															
1N4728	3.3	76.0	10.0	1N4738	8.2	31.0	4.5	1N4748	22.0	11.5	23.0	1N4758	56.0	4.5	110.0
1N4729	3.6	69.0	10.0	1N4739	9.1	28.0	5.0	1N4749	24.0	10.5	25.0	1N4759	62.0	4.0	125.0
1N4730	3.9	64.0	9.0	1N4740	10.0	25.0	7.0	1N4750	27.0	9.5	35.0	1N4760	68.0	3.7	150.0
1N4731	4.3	58.0	9.0	1N4741	11.0	23.0	8.0	1N4751	30.0	8.5	40.0	1N4761	75.0	3.3	175.0
1N4732	4.7	53.0	8.0	1N4742	12.0	21.0	9.0	1N4752	33.0	7.5	45.0	1N4762	82.0	3.0	200.0
1N4733	5.1	49.0	7.0	1N4743	13.0	19.0	10.0	1N4753	36.0	7.0	50.0	1N4763	91.0	2.8	250.0
1N4734	5.6	45.0	5.0	1N4744	15.0	17.0	14.0	1N4754	39.0	6.5	60.0	1N4764	100.0	2.5	350.0
1N4735	6.2	41.0	2.0	1N4745	16.0	15.5	16.0	1N4755	43.0	6.0	70.0				
1N4736	6.8	37.0	3.5	1N4746	18.0	14.0	20.0	1N4756	47.0	5.5	80.0				
1N4737	7.5	34.0	4.0	1N4747	20.0	12.5	22.0	1N4757	51.0	5.0	95.0				
2.5 WATT — CASE 10 MOULDED															
1N5008	3.3	189.0	6.0	1N5019	9.1	69.0	2.4	1N5030	20.0	31.0	9.0	1N5041	47.0	13.0	33.0
1N5009	3.6	173.0	5.5	1N5020	10.0	62.0	3.0	1N5031	22.0	28.0	9.6	1N5042	50.0	12.0	36.0
1N5010	3.9	160.0	5.0	1N5021	11.0	57.0	3.6	1N5032	24.0	26.0	10.0	1N5043	51.0	12.0	36.0
1N5011	4.3	145.0	4.0	1N5022	12.0	52.0	4.2	1N5033	25.0	25.0	11.0	1N5044	52.0	12.0	39.0
1N5012	4.7	133.0	3.5	1N5023	13.0	48.0	4.8	1N5034	27.0	23.0	12.0	1N5045	56.0	11.0	45.0
1N5013	5.1	122.0	3.0	1N5024	14.0	45.0	5.4	1N5035	30.0	21.0	15.0	1N5046	62.0	10.0	51.0
1N5014	5.6	111.0	2.5	1N5025	15.0	42.0	6.0	1N5036	33.0	19.0	18.0	1N5047	68.0	9.2	57.0
1N5015	6.2	101.0	3.0	1N5026	16.0	39.0	6.6	1N5037	36.0	17.0	21.0	1N5048	75.0	8.3	66.0
1N5016	6.8	92.0	1.6	1N5027	17.0	37.0	7.2	1N5038	39.0	16.0	24.0	1N5049	82.0	7.6	78.0
1N5017	7.5	83.0	1.8	1N5028	18.0	35.0	7.8	1N5039	43.0	15.0	27.0	1N5050	91.0	6.9	90.0
1N5018	8.2	76.0	2.1	1N5029	19.0	33.0	8.4	1N5040	45.0	14.0	30.0	1N5051	100.0	6.2	120.0

Case Code	Cap/Voltage Range		Dimensions	Notes
	Min/Max μ fd	Min/Max Volts		
TX	.68/39	4/100	Length .375 Dia. .130	Same Mil "B" case ratings in smaller package
TN	.0023/3.4	4/100	Length .540 Max Dia. .092 Max	Non-Polar version of Item 13
TAN	.14/6.0	4/100	Length .530 Max Dia. .160 Max	Non-Polar version of Item 14
TXN	.34/19	4/100	Length .750 Max Dia. .160 Max	Non-Polar version of Item 15
SX	.0047/8.2	4/100	Length .200 \pm .031 Dia. .091 \pm .005	Same ratings, but 20% shorter than Item 13 — Epoxy End Sealed
SY	.33/12	4/100	Length .250 \pm .031 Dia. .091 \pm .005	Same size as Item 13 with limited extended ratings — Epoxy End Sealed

Case Code	Cap/Voltage Range		Dimensions	Notes
	Min/Max μ fd	Min/Max Volts		
SXN	.0023/4.1	4/100	Length .430 Max Dia. .092 Max	Non-Polar version of Item 19
SYN	.16/6.0	4/100	Length .530 Max Dia. .092 Max	Non-Polar version of Item 20
WA	.0047/22	6/100	Height .225 \pm .015 Length .285 \pm .015 Width .170 \pm .015	Epoxy case-ideal for plug-in circuits
WB	1.0/68	6/100	Height .305 \pm .015 Length .360 \pm .015 Width .170 \pm .015	Epoxy case-ideal for plug-in circuits
WC	6.8/220	6/50	Height .375 \pm .015 Length .600 \pm .015 Width .195 \pm .015	Epoxy case-ideal for plug-in circuits

NOTE: Check with factory or factory representative for specific capacitance and voltage combinations.

SPECIAL PRODUCTS

Dickson offers a select group of solid-state circuit breakers, time-delay and optical relays for use in a wide range of power control applications.

Solid-State Circuit Breakers — Dickson solid-state circuit breakers offer microsecond protection from overcurrent or overvoltage. Response time in microseconds can even provide momentary surge protection with automatic reset. Models with manual and push-button reset also are available. For further information, request data sheets on Series 1100, 1200, 1300.

Time Delay Relays — These devices are all solid-state in epoxy packages, and are available in both two and

three terminal configurations. They can be supplied with fixed delay times up to 180 seconds using 28VDC, and can supply loads of up to 50 mA at 85°C. For further information, request data sheets on Models DTR and DDR.

Optical Relays — These relays are all solid-state and ideal for applications requiring fast response to light beam interruption. Illumination trip and 1000 candlefeet. Maximum Contact Rating 250 mA. For further information, request a data sheet on Model D002025-35.

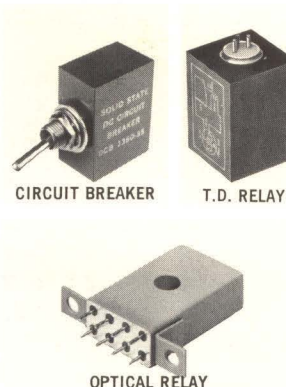

DICKSON REGIONAL REPRESENTATIVES

A



NEW ENGLAND

KITCHEN & KUTCHIN, INC.
17 Waltham St., Lexington, Mass. 02173
(617) 862-8230, TWX 617 862-1386
152 Temple St., New Haven, Conn. 06510

METROPOLITAN NEW YORK (including Long Island

and Northern New Jersey)
ELECTRICAL MANUFACTURERS SERVICES
3170 Veterans Memorial Highway
Bohemia, N.Y. 11716
(516) 585-3100
TWX 516 588-3728

NEW YORK STATE (except Metropolitan New York area)

ADVANCED COMPONENTS CORPORATION, INC.
119 Luther Ave., Liverpool, N.Y. 13088
(315) 472-7886, TWX 315 477-1090

DELAWARE, EASTERN PENNSYLVANIA, SOUTHERN NEW JERSEY

THOMAS ASSOCIATES, INC.
138 Haddon Ave., Haddonfield, N.J. 08033
(609) 854-3011

MARYLAND, VIRGINIA, DISTRICT OF COLUMBIA

J. A. DOUGHERTY CO.
320 Hillen Rd., Towson, Md. 21204
(301) 823-0431

WESTERN PENNSYLVANIA, OHIO, WEST VIRGINIA,

KENTUCKY, INDIANA

GIBSON ELECTRONICS MARKETING CO.
Far Oaks Bldg., Room 110, 2801 Far Hills Ave.,
Dayton, Ohio 45419 (513) 298-7683
2643 Streetsboro Rd., Hudson, Ohio 44236

ALABAMA

BOSTICK & ASSOCIATES
P.O. Box 4165
Huntsville 35802
(205) 881-3677

NORTH CAROLINA, SOUTH CAROLINA, GEORGIA, MISSISSIPPI,

TENNESSEE, LOUISIANA

BILL HENRY ASSOCIATES
1043D Providence Rd., Box 6097, Charlotte, N.C. 28207
(704) 375-8958, TWX 704-525-2627
247 Phosphor Ave., Metairie, La. 70005
(504) 833-3731

FLORIDA, PUERTO RICO

W. BEN WIMBERLY CO.
532 S. Ft. Harrison Ave., Clearwater, Fla. 33516
(813) 446-7072, TWX 813 442-2378
500 S. Osceola St., Orlando, Fla. 32801
(305) 425-3083, TWX 305 275-1358

MICHIGAN

VILLANI-PITCHER, INC.
20203 Ann Arbor Trail, Dearborn, Mich. 48127
(313) 581-5600



V

A



MINNESOTA

E. C. ELECTRONIC SALES
10108 Abbott Ave. S., Minneapolis, Minn. 55431
(612) 888-4626

NORTHERN ILLINOIS, WISCONSIN

R. L. HANNA CO.
Box 202, Palatine, Ill. 60067
(312) 358-3940

MISSOURI, KANSAS, NEBRASKA, SOUTH DAKOTA, NORTH DAKOTA

S. ILLINOIS, IOWA

FLORENCE & MEYER
406 W. 34th St., Kansas City, Mo.
(816) LO 1-7282

2900 Woodland, Wichita, Kansas
(316) TE 8-7226

6050 Brown Rd., Berkeley Station, St. Louis, Mo.
(314) JA 1-6800

TEXAS, OKLAHOMA, ARKANSAS

CARTER ASSOCIATES INC.
Box 87, Garland, Texas 75040
(214) 276-7151, TWX 214 276-8397

Box 22674 Houston, Texas 77027
(713) 622-0844 TWX 713-571-3142

ARIZONA, NEW MEXICO, NEVADA

CARTER ASSOCIATES, INC.
Box 99, Scottsdale, Ariz. 85252
(602) 947-4355, TWX 602 949-0123

COLORADO, UTAH, WYOMING, MONTANA, IDAHO

HYER ELECTRONICS CO.
7895 E. Prentice Ave., Englewood, Colo. 80110
(303) 771-5285, TWX 303 771-4949

WASHINGTON, OREGON

JON B. JOLLY
69 Marion St., Seattle, Wash. 98104
(206) 623-7060

NORTHERN CALIFORNIA

JACK PYLE CO.
1611 Borel Place, Suite 4, San Mateo, Calif. 94402
(415) 349-1266 TWX 910-374-2354

SOUTHERN CALIFORNIA (except San Diego)

ENGINEERING LIAISON ASSOCIATES
3360 Barham Blvd., Hollywood, Calif. 90028
(213) 469-2283, TWX 213 876-4086

SAN DIEGO

T-J ELECTRONICS, INC.
1169 Cushman Ave., San Diego, Calif. 92110
(714) 291-2900

CANADA

GARRETT MANUFACTURING LTD., Aero Sales Division
4 Racine Rd., Rexdale, Ont., Canada
(416) 244-5655



V

IF YOU WERE
"PASSED"
ON
DICKSON'S
"FULL HOUSE"
BROCHURE
HERE . . .

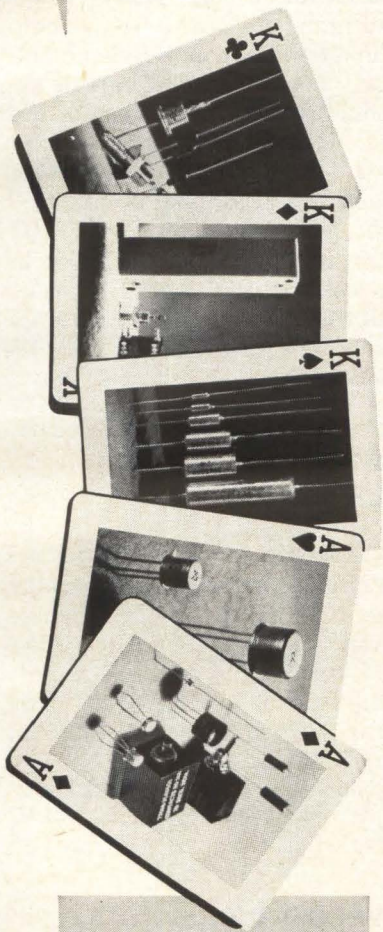

...ASK
FOR
DICKSON
A
RE-DEAL

CIRCLE NUMBER 485
on the
ELECTRONICS
Reader Service Card

New Components

slotted screw. The pin-equipped version is 0.265-in. high because of a high temperature plastic base, while the wire-lead type is 0.2-in. high and has a one-piece all-aluminum base.

Since both versions of the TSI have two mounting holes on 0.525-in. centers, they are interchangeable and can be stacked one on top of the other.

Both the TT1 and TSI series are designed to meet or exceed requirements of MIL-R-27208A. Technology Instrument Corp. of California, 850 Lawrence Drive, Newbury Park, Calif. [355]

Small r-f capacitors carry high current

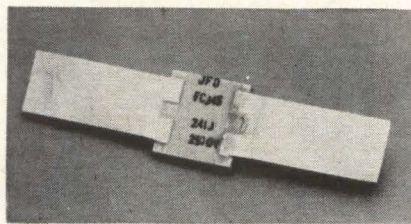

Miniature, glass-encapsulated r-f capacitors can be used in spaceborne, airborne and mobile radio transmitters. The manufacturer says the units carry higher current than other capacitors of the same size.

The FCJ45 series is available in capacitance values of 20 picofarads or lower, or up to 3,000 pf. Typical is the 1,000-pf unit rated at 2,500 v d-c and 5 amps r-f. It is 1/2-in. square and 1/16 in. to 1/8 in. thick $\pm 1/32$ in. Standard tolerances of 1%, 2%, 5%, 10% and 20% are furnished. The units have high insulation resistance and the glass encapsulation insures an hermetic seal.

The capacitors pass all applicable environmental tests of MIL-STD 202. The high-Q dielectric can withstand a temperature range from -55° to $+125^{\circ}$ C.

The capacitors are normally supplied with fine silver wide-ribbon leads, approximately 0.350 in. wide. However, they are also available in wafer form without leads. JFD Electronics Co., 15th Ave. at 62nd St., Brooklyn, N.Y., 11219. [356]

Radar Equipment Design Engineers

The Hughes Radar & Space Electronics Laboratories have important opportunities available for experienced Engineers.

System oriented

Engineers, Physicists and Analysts are required for the conceptual design of advanced radar, laser and telecommunication systems. Desirable background would include a broad knowledge of the state of the electronic art and specific experience in sensors, signal processing and communication theory.

Openings are available on nearly all levels—from those with a minimum of two years of applicable, professional experience through those who are interested in and qualified for senior supervisory positions.

Accredited degree and U.S. citizenship required.

For immediate consideration, please airmail your resume to:

MR. ROBERT A. MARTIN
Head of Employment
Hughes Aerospace Divisions
11940 W. Jefferson Blvd.
Culver City 67 California

HUGHES

HUGHES AIRCRAFT COMPANY
AEROSPACE DIVISIONS

An equal opportunity employer — M & F

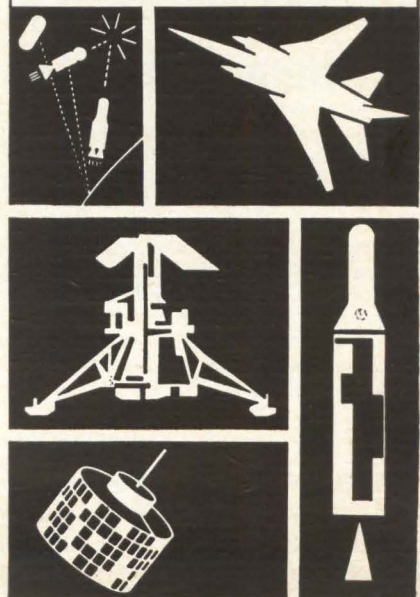

**Design
any
custom
header
you
need**

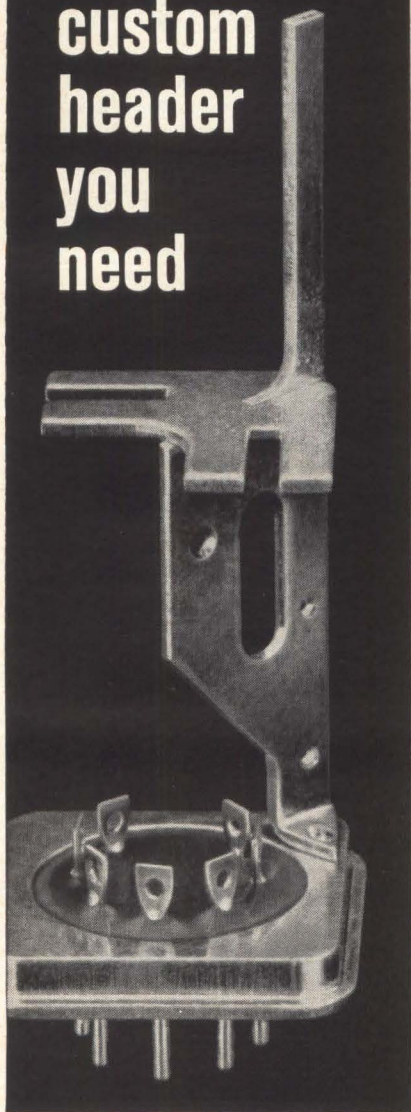

... then call Atlas

We can manufacture it . . . and test it . . . to your specs. And do it more economically than you can do it yourself. For example, here's how Atlas engineers solved the problem of spot-welding a bracket to a header without cracking the glass seal—we weld the bracket on *before* we form the seal. And the testing is done in *our* environmental chambers—to your own or MIL specs—so we know it's done right. That way, rejects are our problem, not yours. For detailed information, call or write our marketing department today. Area 215 666-0700.

ATLAS
CHEMICAL INDUSTRIES, INC.
Aerospace Components Division
Valley Forge, Pa. 19481

New Semiconductors

Computer diodes offer high stability

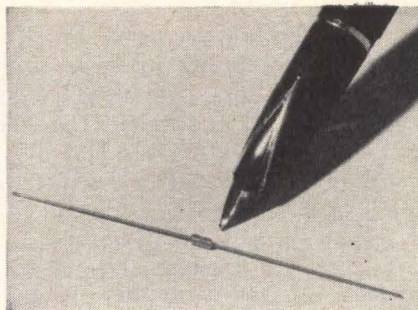

A family of silicon diodes features a compact package and planar epitaxial construction. The series of six high-speed computer switching diodes, 1N4148-49 and 1N446-49, has electrical characteristics equivalent to the 1N914 family.

Reverse breakdown voltage ($I_R = 100 \mu a$) is 100 v minimum. Reverse recovery time is 4 nsec maximum.

The DO-35 is 50% smaller than the standard DO-7 package, mak-

ing possible greater component density in space-critical computer applications. The planar epitaxial construction offers even greater stability and reliability, particularly during high-temperature operation.

Only four component parts are used to assemble the device: the glass-passivated silicon wafer; two plug-leads that serve as mounting and contact areas for the active element; and a glass sleeve encapsulating the device. All components are in a thermal-compression bond. Closely matched coefficients of expansion assure maintenance of the bond. The whiskerless design results in increased protection against shock and vibration.

The new epitaxial planar Uni/G diodes are immediately available in high volume with short lead time. Representative pricing is from 25 cents to 99 cents in 100 to 999 quantities.

Texas Instruments Incorporated, 13500 North Central Expressway, Dallas, Texas. [361]

Glass zeners designed for regulator use

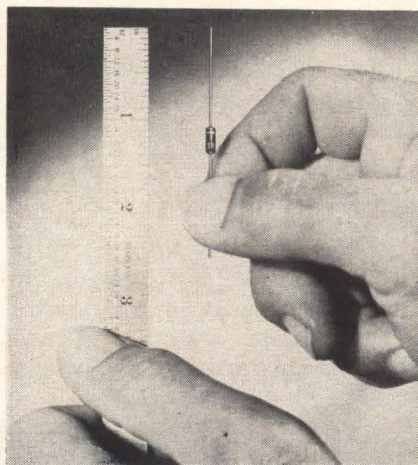

A series of glass zener voltage regulators, G3 through G12, is offered for regulator and other industrial and commercial applications where stable long-term operation is required. The glass configuration offers small size—DO-7—and is especially suited for high density packaging applications.

The 1-watt voltage regulator series offers a nominal zener voltage range from 3.0 to 12 v and voltage tolerance of $\pm 20\%$, $\pm 10\%$, and $\pm 5\%$.

Price of the units is 73 cents each for 20% tolerance units in lots of 100 to 999.

International Rectifier Corp., 233 Kansas St., El Segundo, Calif., 90245. [362]

Low-cost transistors deliver power at uhf

Healthy power output in the microwave region at a reasonable price is the salient feature of a new series of ultrahigh-frequency overlay transistors.

The minimum power output of the MM1500 is 250 mw at 1.5 Ghz, and for applications with lower power requirements the new series includes the MM1501 transistor (150 mw minimum at 1.0 Ghz).

These power transistors, housed in a wide flange case for easy mounting in cavity circuits, are



When it comes to electrical tapes, Mystik is king!

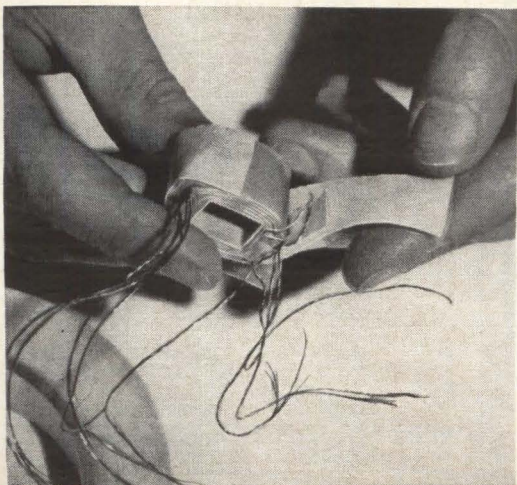

No doubt about it, Mystik leads the field in special-purpose tapes. Our extensive line of top quality products are perfect for hundreds of applications ranging from conventional industrial uses to the more sophisticated demands of the space age.

Mystik tapes are made in a wide range of materials including paper, plastic, cloth and glass cloth as well as many types of films and foils. They provide physical and performance characteristics of every description and are suitable for binding, shielding, strapping and insulating. Mystik pioneered tapes with heat-resistant silicone adhesives that grip like a vise even when exposed to high temperatures. Other new tapes are continually being developed to keep pace with the needs of the rapidly-expanding electrical industry.

We'll gladly prove our right to the "crown". Our local distributor will assist you in selecting the right tape for your application. He's in the Yellow Pages under "Tape" or write The Borden Chemical Co., Mystik Tape Div., 1700 Winnetka Ave., Northfield, Ill.



**BORDEN
CHEMICAL**

Ultra Stable

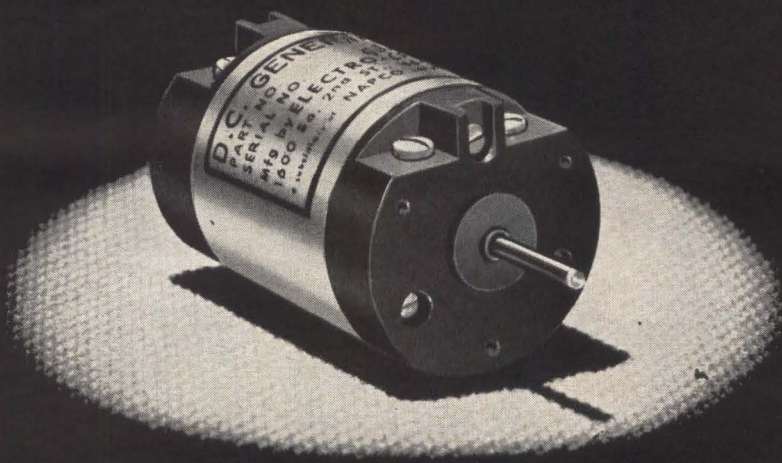

Precision DC Tachometer Generator 0.01% per °C stability

ELECTRO-CRAFT, responding to industry demand, has developed a dc tachometer generator with performance characteristics not found in any other unit ■ excellent stability ■ 1% linearity ■ completely shielded ■ over 100,000 hour life ■ available also as precision motor or motor-generator with matching transistorized amplifiers ■ Our application engineers will be pleased to help you in solving your systems problems. Write or call today. Or even better, order a prototype. It's only \$35.00. And it will tell you much more than these 90 words can.

If your problem is Speed Control, your solution is . . .



ELECTRO-CRAFT CORPORATION
1600 S. Second St., Hopkins, Minn. 612-935-8226

New Semiconductors

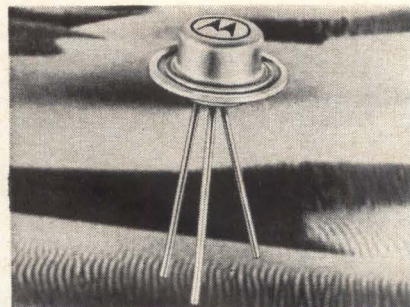

useful as local oscillators for radar systems, telemetry, and proximity fuses and for varactor drivers.

The multiple-emitter overlay design lengthens the emitter perimeter in relationship to the area of the emitter, and provides the increased power capabilities of the transistor at these high frequencies.

Prices for the MM1500 are \$28 each in quantities of 100 and up; for the MM1501, \$18 each in quantities of 100 and up. Delivery is immediate.

Motorola Semiconductor Products Inc., Box 955, Phoenix, Ariz., 85001. [363]

Fast, silicon photodetectors

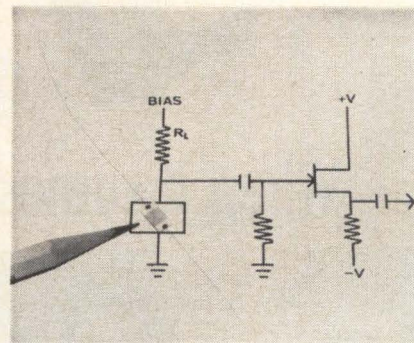

Photoconductive silicon photodetectors offer better combinations of detectivity, rise time and responsivity than presently available photo junction devices, according to the manufacturer. Detectivity is 5×10^{11} cm $\text{hz}^{1/2}/\text{watt}$; responsivity, 2×10^5 v/w; and rise time, 4 μsec with a 0.5-megohm load.

Until now, the theoretical advantages of photoconductive operation have not been realized because of electrode deposition problems and

the lack of high purity intrinsic silicon. The manufacturer says it has overcome these problems in the fabrication of the new detectors. Featuring active area dimensions ranging from 1 to 15 mm, SPC photodetectors can be made in a variety of shapes and electrode configurations.

Mithras, Inc., 701 Concord Ave., Cambridge, Mass., 02138. [364]

Photochopper cells need little warm-up

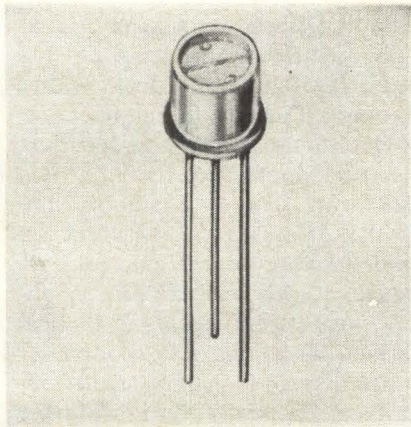

High efficiency plus the temperature stability and low light memory of cadmium sulfide are combined in a pair of photochopper cells. Efficiency levels of the two cells, in spdt configuration, range up to 72% at 1 khz, 93% at 400 hertz and 98% at 60 hz. Temperature coefficient is low, so that efficiency change from -25° to 60° C is less than 15%, one-third to one-quarter the variation of cadmium selenide photochopper cells.

The new cells are: type CL906CS with an on resistance of 82 kilohms; and a low-resistance type CL906CLS, with an on resistance of 2.75 kilohms. On resistance is guaranteed within $\pm 50\%$, while comparable cadmium selenide cells only guarantee an on resistance no greater than a stated value. The low light memory of the type 6C cadmium sulfide material in the cells essentially eliminates warm-up time. The devices reach normal resistance in a minute. Cadmium selenide cells require 10 minutes or more to exhibit normal resistance to a given light level. Clairex Corp., 1239 Broadway, New York, N.Y., 10001. [365]

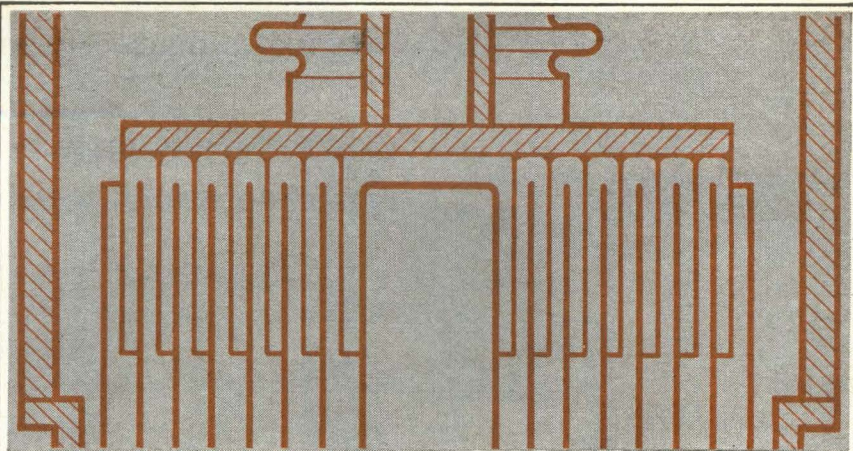

Why do Jennings vacuum capacitors meet every requirement? There's nothing to it

Ultra high vacuum dielectric combined with Jennings exclusive capacitor design is the answer. This combination has been a major factor in the development of modern transmitters. New vacuum capacitor designs from Jennings will contribute even more to the advancement of transmitter design. They can also help solve some of your immediate problems.

Jennings has hundreds of standard fixed and variable vacuum capacitors in a wide variety of capacity, voltage, and current levels. In all probability the capacitor you need has already been designed, field tested, and proven reliable. If it hasn't you couldn't find a more experienced company than Jennings to design a new one.

USL-500

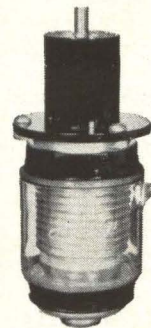

Capacity Range: 5-500 pF
Peak Test Voltage: 5 KV
RF Current: 40 Amps RMS
Height: 5-3/4"
Width: 2-3/8"

CFHP-1000



Capacity: 1000 pF
Peak Test Voltage: 45 KV
RF Current: 215 Amps RMS
Height: 5-1/2"
Width: 5-1/2"

CVCC-2500



Capacity Range: 25-2500 pF
Peak Test Voltage: 7 KV
RF Current: 75 Amps RMS
Vibration: 5G to 500 cps
(with less than 3 pF capacity shift)

CVDD-500

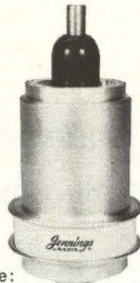

Capacity Range: 20-500 pF
Peak Test Voltage: 15 KV
RF Current: 80 Amps RMS
Height: 7-1/2"
Width: 3-3/4"

For complete information on ITT Jennings vacuum capacitors, write for our new catalog No. 101. ITT Jennings, a subsidiary of International Telephone and Telegraph Corporation, 970 McLaughlin Avenue, San Jose, California 95108.

JENNINGS ITT

**HOW DID
TRYGON
IMPROVE THE
MOST VERSATILE
POWER SUPPLY
\$249
CAN BUY?**

**THE DUAL OUTPUT
DL 40-1**

It was already a winner: dual output, dual range—two power supplies in one—with two independently adjustable outputs, series-parallel combinations for 8 different outputs. We kept all that and—

- Increased power by 50%—to 1 amp. Now, each independent output provides 0-40 v at 500 ma, or 0-20 v at 1 amp.
- Added the calibrated adjustable current-limiting feature you wanted.

We kept the—

- Compact half-rack size
- The old price of \$249.

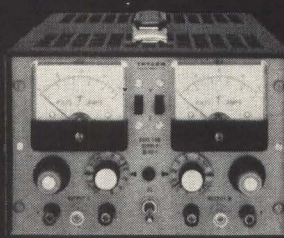

Those are the highlights of this new, improved power supply. Get all the facts.

MAIL THE COUPON TODAY.



PLEASANT AVE., ROOSEVELT, L.I., N.Y.

Please rush me your new 52-page Power Supply Handbook—FREE

Name _____
 Title _____
 Company _____
 Address _____
 City _____ State _____ Zip _____

New Instruments

**Video amplifier tests
crystal detectors**

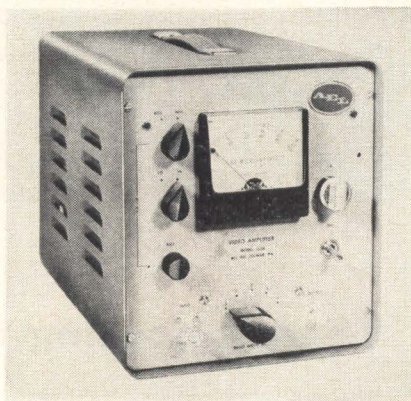

Testing high-impedance microwave crystal detectors is one use for a recently developed portable, low-noise video amplifier. It has five basic adjustable-bandwidth frequency ranges from 0.5 to 5 Mhz. Convenience of operation is enhanced by a built-in bias supply, with a front panel meter covering 0 to 85 microamps in two ranges.

Model 153A features a gain of 65 db minimum at 10 kilohertz, and an input impedance at 1 Mhz of greater than 350,000 ohms and less than 10 picofarads $\pm 10\%$. Equivalent input noise resistance is less than 750 ohms. Polarity is reversing, and power requirements are 117 v a-c, 60 hz, 60 w.

Envelope dimensions are 8x9x12 in. Price is \$495.

American Electronic Laboratories, Inc., P.O. Box 552, Lansdale, Pa., 19446 [371]

**Solid state sweeper
offers plug-in design**

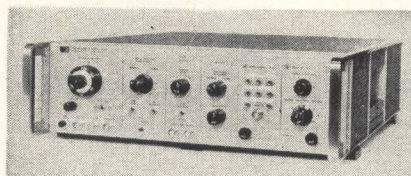

Output greater than 0.7 v is obtained, with compactness and light weight, through solid state design in a sweep oscillator that spans 100 khz to 100 Mhz. Model 3211A has

two plug-in positions. One determines the range of sweep frequencies; the other accepts as many as eight plug-in marker cards, each with its own frequency-determining crystal.

Using off-the-shelf plug-ins, and exploiting the instrument's built-in wide range of operating modes, the oscillator will meet the needs of almost any special test program at reasonable cost, the manufacturer says. The sweeper will fulfill new requirements quickly and at minimal cost with new plug-ins.

The marker functions of the model are different from other sweepers. Each of the eight markers has its own front-panel switch. A birdie bypass marker system transforms marker beatnotes into video pulses. Video pulses can be applied either to the detected response of the test circuit, to obtain positive or negative vertical markers, or to the Z axis input of an oscilloscope, which yields intensity-modulated dots. Marker sensitivity and bandwidth are front-panel controls. Additional external markers may be added through a front panel input.

Sweep rates from 10 to 100 per second are continuously selectable with each plug-in. Single sweep may be chosen, and provision is made for sweeps of 1 to 10 seconds compatible with X-Y recording needs.

Among the sweeper's applications are design, calibration and alignment of f-m tuners and receivers, and the general testing of i-f sections and other circuits in the video-to-vhf range.

The sweep oscillator costs \$665; the 3221A marker plug-in, \$85. Marker plug-in boards are \$40 each.

Hewlett-Packard Co., 1501 Page Mill Rd., Palo Alto, Calif., 94304. [372]

**Radar range calibrator
marks time too**

A high-precision triggered calibration standard and a time mark generator have been combined in one lightweight instrument. Meeting

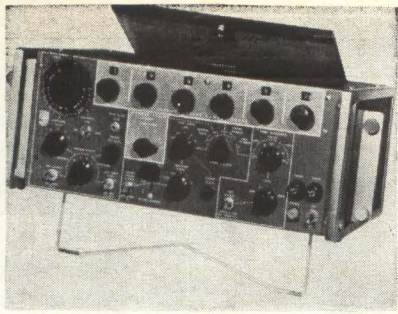

military specifications, the model is designed to calibrate radar displays, simulators, radar range calibrators, long-range tracking equipment, short-range gun control equipment and oscilloscopes. It can also generate an accurate adjustable triggered delay.

Less than 20-nsec jitter in its range ensures excellent display clarity even with external triggering. Better than 0.0025% \pm 5 yards accuracy is maintained throughout the full operating range of 25 yards to 2 million yards. A built-in pulse-repetition-frequency generator provides internal triggering from 50 hertz to 5 khz. A prf pulse is also available for triggering associated equipment.

The RM138A is completely solid state using high quality professional and military type semiconductors and components, the company reports. It has been designed to resist corrosion in humid environments. Components are mounted in plated holes on circuit cards. Rotary switches incorporate stainless steel shafts; high-quality wafer material and coin silver contacts.

Philips Electronic Equipment, a division of Philips Electronics Industries Ltd., 116 Vanderhoof Ave., Toronto 17, Ontario, Canada. [373]

Stable, sensitive peak power meter

Accurate measurement in high r-f environments is the salient feature of the type 6690 peak power meter. The stable, solid state instrument's measuring circuitry is encased in an r-f shielded module. A cut-off tube is used with the range switch for extreme attenuation of the r-f interference.

Full-scale readings of 30, 100, and 300 mw are covered in four

New! -- Ballantine Solid State True RMS Voltmeter

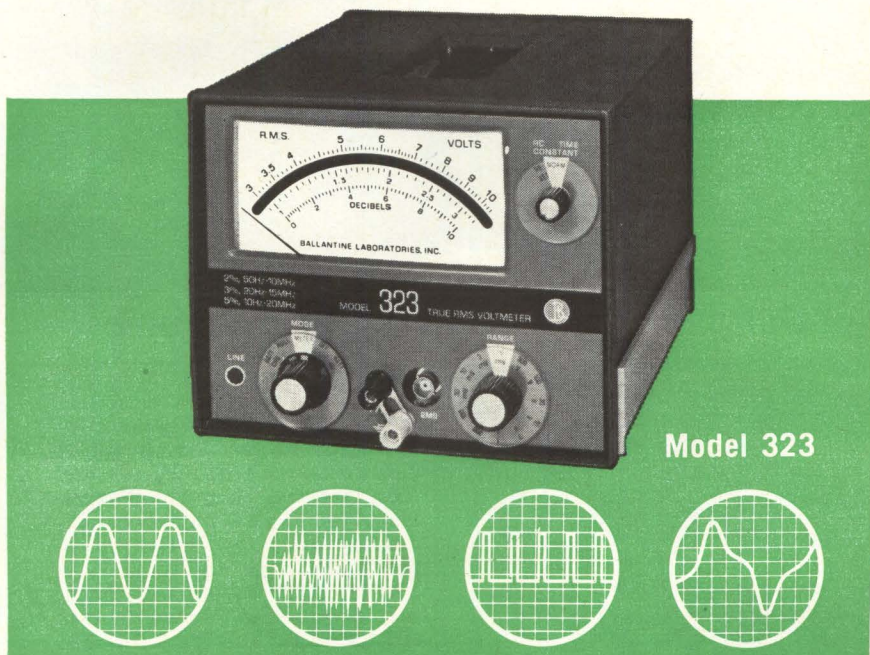

Measures from 10 Hz to 20 MHz regardless of Waveform

Ballantine's new Model 323 is a rugged, all-solid-state voltmeter for True RMS measurements for 10 Hz to 20 MHz . . . and for a wide variety of waveforms. Use it as a completely portable instrument isolated from line effects (due to built-in rechargeable batteries), or plug it into the power line. (Model 323-01 is for use on power line, only.)

FEATURES:

- ★ Measures True RMS of sine waves, square waves, noise voltages and a range of pulses
- ★ Frequency range of 10 Hz to 20 MHz
- ★ Voltage range of 300 μ V to 330 V. (As null detector to 70 μ V)
- ★ Unmatched accuracy: 2% of indication, 50 Hz to 10 MHz; 3% of indication, 20 Hz to 15 MHz; 5% of indication, 10 Hz to 20 MHz. Ballantine's accuracy of 2% means 2% of the actual indication, whether at the top or bottom of a scale
- ★ Operates from built-in rechargeable batteries or line power
- ★ Ideal for recorder applications — DC output of 0.1 to 1.0 V for each range simultaneous with meter reading
- ★ Crest factor: 5 at full scale to 15 at down scale
- ★ Separate isolated signal and case grounds
- ★ Optional 80 dB Attenuator Probe, Model 1301, for operation up to 10,000 V

Prices: Model 323, \$520 (Battery & Line)
Model 323-01, \$485 (Line only)



BALLANTINE LABORATORIES INC.

Boonton, New Jersey

CHECK WITH BALLANTINE FIRST FOR DC AND AC ELECTRONIC VOLTMETERS/AMMETERS/OHMMEASUREMENTS, REGARDLESS OF YOUR REQUIREMENTS. WE HAVE A LARGE LINE, WITH ADDITIONS EACH YEAR. ALSO AC/DC LINEAR CONVERTERS, AC/DC CALIBRATORS, WIDE BAND AMPLIFIERS, DIRECT-READING CAPACITANCE METERS, AND A LINE OF LABORATORY VOLTAGE STANDARDS FOR 0 TO 1,000 MHZ.

Capacitors and Resistors

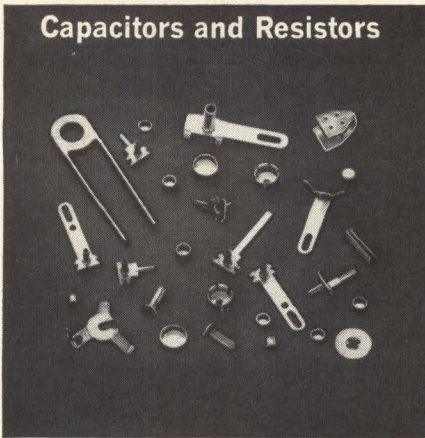

Relays

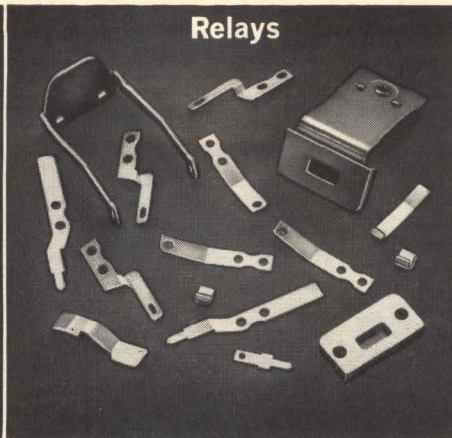

Our parts go into everything electronic



Connectors

Producers of *all types* of electronic components have their reasons for relying on Volkert Stampings. It comes out in the extra things Volkert does. Like converting a multi-piece design to a single stamping. Or consistently using high-speed equipment to reduce per-part costs.

Write or call Volkert Stampings, Inc., 222-35 96th Avenue, Queens Village, L. I., New York 11429. Telephone 212-464-8400.

Volkert STAMPINGS, INC.

Subsidiary of The Stanley Works

Circle 248 on reader service card

Photocell Decay Problems?

*Typesetter
lost a zero.
This should be
.0006*

Try Type 7H

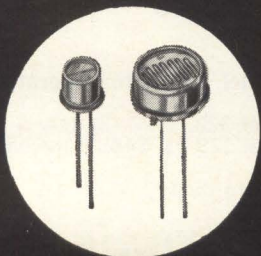

Clairex Type 7H Photocells now offer decay times of .006 sec @ 100 ft-c. Couple this with 240 ohms @ 100 ft-c, CdS stability, and your problems are solved. Available in TO-18 and TO-5 cases. And 6 resistance ranges.

CLAIREX

"The LIGHT Touch in Automation and Control"

1239 Broadway, New York, N.Y. 10001

212 MU 4-0940

190 Circle 190 on reader service card

New Instruments



steps with an accuracy of ± 0.2 db. In the 30-mw, narrow-band position, the unit can make accurate measurements below 5 mw.

Features include: sensitivity adjustment to match a wide range of bolometers; instrument components meet military specs for reliability; solid state design; optional battery pack and measurements to 300-mw peak power independent of frequency, pulse width, repetition frequency, and pulse shape.

PRD Electronics Inc., 1200 Prospect Ave., Westbury, L.I., N.Y., 11590. [374]

Counter features high sensitivity



A 12.5-Mhz electronic counter combines a six-digit Nixie readout, automatic decimal point and units indicator and all five counter measuring functions (frequency, time interval, period and multiple period averaging, ratio, and totalizing). The unit measures $6\frac{3}{4}$ in. high by $7\frac{7}{8}$ in. wide. It is designed for low level work, especially pulses and is claimed to be 10 times more sensitive than a conventional electronic counter. It counts 10 mv sine waves or pulses with only 100 mv peak

Electronics | January 23, 1967

amplitude. Pulses down to 50 nsec can be accommodated.

Another provision is the input selector switch that allows the trigger bias level to be altered at near 0 volts for optimum response to either sine waves or pulses, positive or negative.

D-c coupling allows events occurring less often than two per second to be counted, while eliminating any effect an a-c coupled RC time constant might have in counting random width pulses and changing repetition rates. A front panel slide switch allows the internal count frequency to be divided by 1,000 so the desired resolution can be selected for time interval measurements. Start-stop connectors for time interval measurements are on the rear panel.

The internal time base is a 1-Mhz crystal, with aging rate below two parts in 10^7 per month.

The instrument's modular cabinet occupies half of a rack-space 7 inches high. Price is \$1,650, or with option 02 (binary-coded-decimal recorder output), \$1,685. Delivery is five to 10 days.

Hewlett-Packard Co., 1501 Page Mill Rd., Palo Alto, Calif., 94304. [375]

Pressure transducer can take rough usage

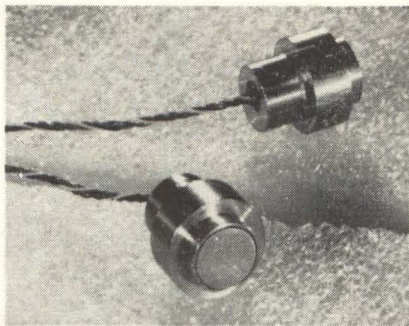

The active diaphragm of a sub-miniature pressure transducer is isolated from strains due to various applied mounting forces by a mounting flange built right onto the transducer. This flange also provides positive positioning and is designed to make the transducer a more rugged unit than some previous models, the company says.

For easier handling, the model SA-SA-M-69 will be supplied with

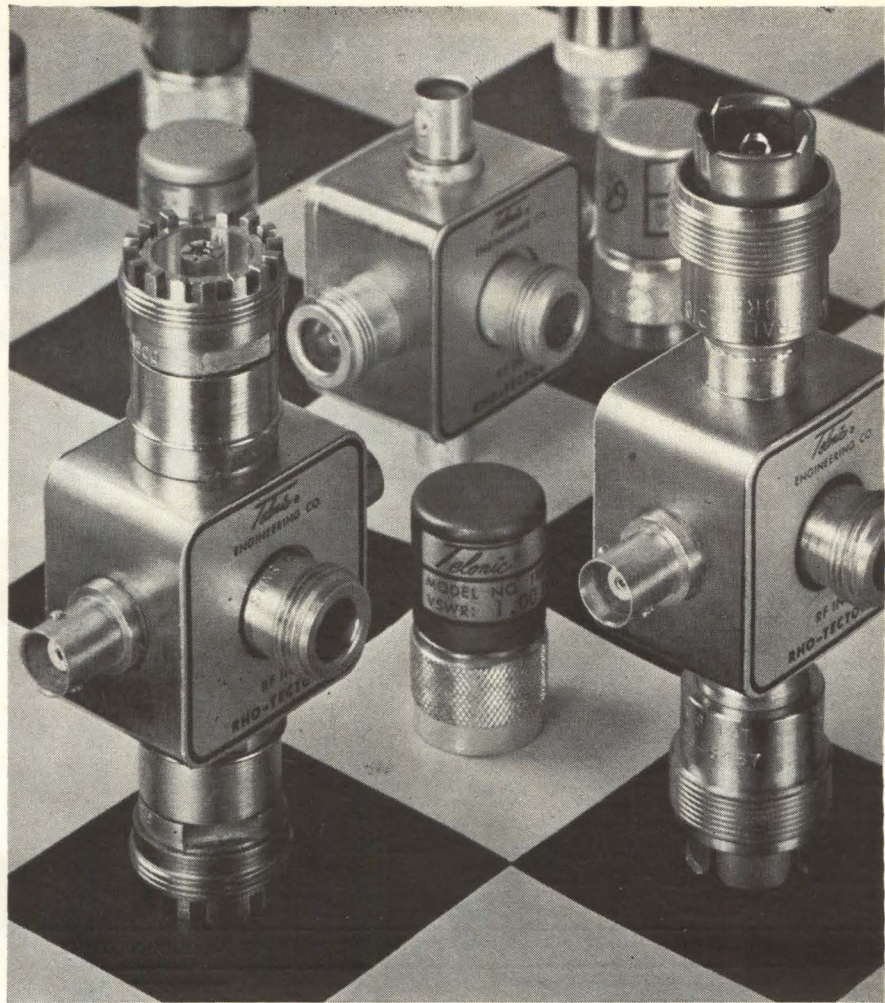

The game is called Swept VSWR

And the winner receives a fast, precise answer to a difficult test problem. Until Telonic developed the Rho-Tector impedance comparator, swept VSWR measurement was usually a fairly complex, and always an expensive, procedure. Now it's simply a matter of hooking up and reading directly from a Telonic Rho-Meter or scope display, or XY recorder at any frequency from .5 to 4000 MHz.

And what kind of accuracies can you expect from something so easy? How about 50 dB?

Model	TRB-1	TRB-2	TRB-3	TRB-4*	TRB-5	TRB-8	TRB-9*	TRB-10
Range in MHz	.5-1000	.5-2500	.5-1000	.5-1000	200-4000	.5-2500	.5-1000	200-4000
Min. Unbalance (Return Loss) in dB	30	30	50	50	30	30	50	30

*with ALC Detector

Complete Guaranteed Specifications in Catalog C-101. Available on request.

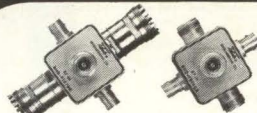

For a complete VSWR measuring system, Telonic provides eight Rho-Tector Models,



Microwave Terminations in 21 VSWR values, (also available in VSWR kits with Rho-Tectors) and



the Rho-Meter for direct read-out of VSWR values.



ENGINEERING CO.

A DIVISION OF TELONIC INDUSTRIES, INC.

P.O. Box 277, Laguna Beach, Cal. 92651—TEL. 714-494-9401 TWX. 910-596-1320

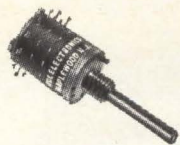

so
precise
each
switch
element
is a
"JEWEL"!



RCL 1/2" ROTARY SWITCHES

- Up to 12 positions per deck with stops.
- As many as 6 poles per deck.
- Shorting and non-shorting poles may be grouped on one deck in any combination.

"Off-The-Shelf" Delivery - Write for complete engineering information

RCL

ELECTRONICS, INC.

General Sales Office: One Hixon Place,
Maplewood, New Jersey 07040

Circle 249 on reader service card

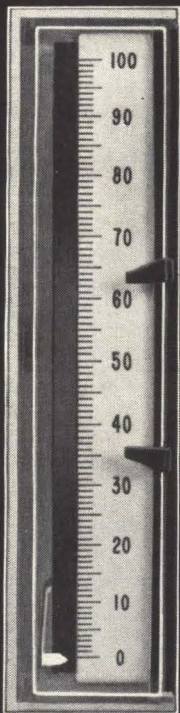

ER-35 MINITROL CONTROL METER
(actual size)

of all meter/relays,
the **PARKER
MINITROL**
is the most compact,
most rugged, simplest,
most dependable

with an array of features never before
available in a single instrument:

- **All-solid-state switching** / no physical contacts, mirrors or prisms . . .
- **Positive repeatable switching** over the entire instrument range . . .
- **Completely self-contained** indicating and control . . .
- **Dual or Single Control Points** with simultaneous switching available . . .
- **Selenide or Light-Activated SCR Cells**, as desired . . .
- **Internal-Switching Capability** to 300 MA at 100V . . .
- **Extreme Compactness** / 7/8"-thin case includes all indicating and control elements, etched-circuit design . . .
- **Multi-Unit Assemblies** of edgewise modules for high-density control/display (14 units per foot)

write for bulletin M-10



**PARKER INSTRUMENT
CORPORATION**
200 Harvard Ave./Stamford/Conn/06904
Phone 203-325-4361

New Instruments

24-in. leads and a terminal connector. The transducer element is 0.250 in. in diameter and provides sensitivity up to 20 mv/v. It utilizes semiconductor type, bonded strain gauges in a fully active bridge for stability. Both differential and absolute models are available in pressure ranges of ± 2 up to 2,000 psi. Internal temperature compensation is available in ranges from -40° to 300°F . These units operate on either d-c or a-c and are compatible with standard strain-gauge instrumentation.

Scientific Advances, Inc., 1400 Holly Ave., Columbus, Ohio, 43212 [376]

Phase meter, shifter offers direct reading

A combination phase meter and phase shifter, model 301A, operates over a frequency range from 30 to 30,000 hertz. The phase angle, when used either as a phase shifter or a phase meter, is read directly from a large circular dial calibrated from 0° to 90° .

A quadrant selector switch allows operation over a full 360° without ambiguity. Measurement accuracy is $\pm 2^\circ$. Input impedance is 10 megohms and sensitivity is 85 mv. The output from the phase shifter is provided by a 300-ohm source and is adjustable from 0 to 5 v rms.

Dytronics Co., Inc., 4800 Evanswood Drive, Columbus, Ohio, 43224 [377]

Sensitive electrometer uses FET for input

The description of this vibrating reed electrometer [Dec. 12, p. 201] contained some errors. The instrument is used with mass spectrometers, not mass spectroscopes. Correct specifications—lowest measurable potential: 2×10^{-5} volts; possible outputs: 10, 25 and 100 millivolts and 1 and 30 volts; current range: 10^{-17} to 3×10^{-7} amps; and charge range: 5×10^{-16} to 6×10^{-10} coulombs.

Cary Instruments, subsidiary of Varian Associates, 2724 S. Peck Road, Monrovia, Calif. 91016

Ambient reference for thermocouples

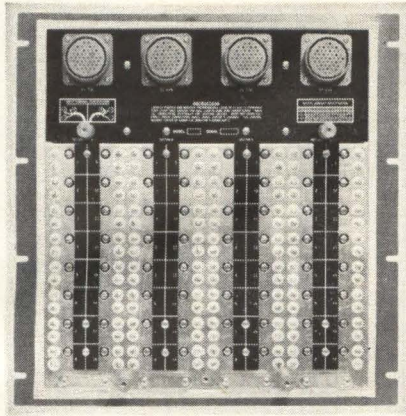

Thermocouples attached to equipment in environmental test chambers are usually referenced to outside junctions whose temperature is held to some fixed standard, such as the freezing point of water. But, claiming that a passive reference is less expensive and more reliable than a controlled reference, Joseph Kaye & Co., Cambridge, Mass., have developed a 64-channel system keyed to the ambient temperature outside the test chamber.

Instead of relating measurement signals from the chamber to a fixed standard, the company's Uniform Temperature Reference UTR system combines the measurement and ambient reference signals; the reference temperature or the voltage generated at the reference temperature is then subtracted out.

Under this system, designed to work with computer-type data-logging gear, thermocouple wires are connected to the equipment being tested to form a measurement junction, a chromel-alumel one, for example. At their other end, the wires are connected to the UTR panel outside the chamber to form two more junctions of chromel-copper and alumel-copper.

The magnitude of the reference signals generated by the junction in the panel is dependent on the ambient temperature outside the test chamber. The combined signals from the thermocouple in the test chamber and those in the UTR panel are then fed on a pair of single wires to multiplexers or directly to a computer input. The

voltage generated at the ambient reference temperature can be electrically subtracted before reaching the multiplexers, or the computer can be programmed to automatically subtract the reference temperature.

The unit will work with any type or combination of types of thermocouples: copper-constantan; chromel-alumel; iron-constantan or platinum-platinum/10% rhodium. Temperature errors are reported to be less than 0.1°F for a linear 20°F-per-hour ambient change and 0.02°F for a linear 5°-per-hour change. If ambient variations are kept very small, junction-to-junction temperature differences approach zero, according to the developers. Channel-to-channel leakage resistances are greater than 1,000 megohms.

The reference system is available from stock and costs \$735.

Joseph Kaye & Co., 737 Concord Ave., Cambridge 38, Mass. [381]

Small power supply delivers high voltage



A power supply that provides up to 1,500 v d-c and 2 ma output with low noise characteristics is available in a military-ruggedized package that occupies 3 cubic inches and weighs 120 grams. Output ripple is 0.1% rms of output voltage. The completely floating output can be adjusted with a screwdriver from 700 to 1,500 v. The units may be easily stacked if increased voltage output is required.

Excellent stability of the HV-15 power supply provides line regulation of 0.15% per volt and load

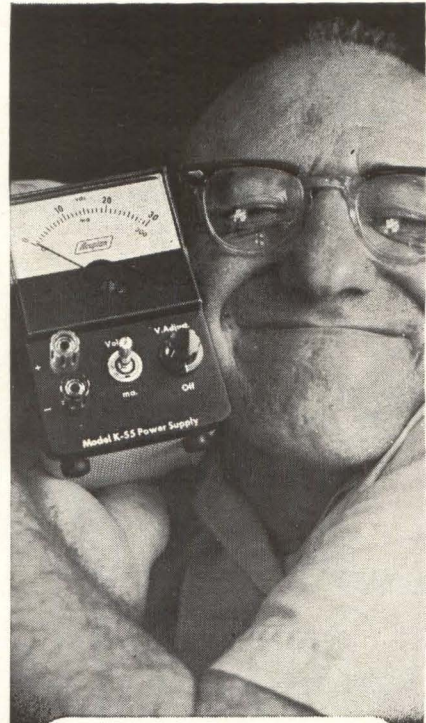

Why not enjoy the luxury of your own power supply?

Now, for only \$98, you can enjoy the luxury of a laboratory power supply right on your own bench. Acopian's new K55 Power Supply delivers 300 ma over an adjustable range of 1.25 to 30 volts DC. It is voltage regulated, all silicon, and electronically protected against shorts. It weighs only three pounds.

Availability? Acopian's usual three days, of course. Get complete information from your local Acopian representative or write Acopian Corp., Easton, Pennsylvania. Phone: (215) 258-5441.



VACTEC

Type O CdS Cells
Fastest
at
Low Light Levels



The response time of any photocell slows proportionately as the light level decreases. But Vactec delivers a rapid response time even at low light levels.

At .01 ft. candles, for example, Vactec Type O material provides a rise time of 780 milliseconds with a delay time of only 90 milliseconds. And you also get the temperature stability provided only by CdS material. Even if yours is a higher light level application, isn't it reassuring to know there is a supplier whose cells are capable of such a high level of performance?

Five new materials ranging from Cadmium Sulfide to Cadmium Selenide are now available. Write for new Bulletin PCD-4 today!

VACTEC  **INC.**

2423 Northline Industrial Blvd.
Maryland Hts., Mo. 63042
AC 314, HE 2-4200

See Vactec's listing in EBG under "Semiconductors," and in EEM, Sec. 3700.

Circle 250 on reader service card

How can you use your scopes, counters and voltmeters over their entire frequency range?

Use an MRC solid state wideband amplifier



Boost weak signals to useful levels by putting an MRC wideband amplifier in the line between the signal and your test equipment. For example, the MRC Model 401 is a 30 dB amplifier operating from 100 Hz to 200 MHz.

We'll be glad to tell you which of our

amplifiers is best suited for your needs. Just drop us a note describing your application. You will receive a catalog describing the extensive line of MRC amplifiers—and our specific recommendations for your application. Or, just request our Amplifier Catalog 13B.

Write Conducrtron—MRC Division, 2311 Green Road, Box 614, Ann Arbor, Michigan 48107.



CONDUCTRON - MRC Division

ANN ARBOR, MICHIGAN



New Subassemblies

regulation of 2.5% from half to full load. Designed to meet all applicable military standards of shock, vibration and temperature, these power converters are suited for use with klystron oscillators, amplifiers, backward wave oscillators and other land, sea or aerospace applications where optimum reliability is essential.

Available from stock, the supplies are \$273 in quantities from 1 to 10. Price and delivery information on larger quantities will be supplied on request.

Mil Associates, Inc., Hudson, N.H., 03051. [382]

D-c power supplies recover rapidly



Precision-regulated, all-solid state power supplies feature constant-current output useful down to the microamp region. Ripple, regulation and stability are orders of magnitude better than comparably priced devices, according to the manufacturer. The compact ccb models can serve as general-purpose lab constant-current sources for semiconductor circuit development and component evaluation and testing. Outputs to 750 milliamperes are available.

A constant-current d-c power supply must change its output voltage rapidly to minimize load current transients. With the ccb series even load changes that require changing the full rated output voltage take less than 200 microseconds to return to within 0.1% of the prescribed current.

On most constant-current power supplies, placing a voltmeter across the output terminals degrades the load regulation and diminishes the load current. The ccb series eliminates this error,

A LOW-COST 4PDT 3 AMP RELAY CAN OUTPERFORM THE HIGHER PRICED ONES.

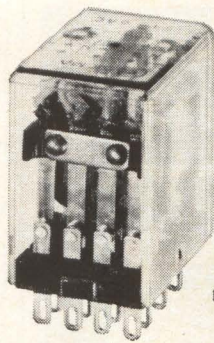

If it's the new
Sigma Series 67.

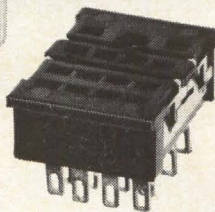

New Sigma Series 67 4PDT 3 amp AC-DC relays are not only priced lower than competitive types but will outperform them four ways:

In Life Expectancy: Slots in contact base between fixed contacts eliminate build-up of vaporized contact material and leakage paths. This feature alone can double relay life expectancy.

In Adjustment Stability: The contact base and movable contact support of the new Series 67 is made of diallyl phthalate. This material does not deform under mechanical and thermal stresses.

In Thermal Resistance: The Series 67 enclosure is made of high heat resistant polycarbonate instead of less resistant nylon. This assures stable operation at high temperatures.

In Fast, Easy Installation: Series 67 solder ter-

minal socket can be installed in seconds, with no need for screws or fasteners. It simply snaps into the face of the panel and four spring clips lock it.

We'd like to give you a new Sigma Series 67—or any of our other standard relays. Test and compare it against the brand you may now be using. It's the best way we know to prove what we say about Sigma relay performance. Just circle our reader service number on the reader service card. We'll send you the new Sigma relay catalog and a "free relay" request form. Return the form to us and your Sigma representative will see that you get the relay you need.

Need fast delivery? The Series 67 is available off-the-shelf from your Sigma distributor.

SIGMA DIVISION  SIGMA INSTRUMENTS INC
Assured Reliability With Advanced Design / Braintree, Mass. 02185

CEI's Sensitive New VHF Receiver

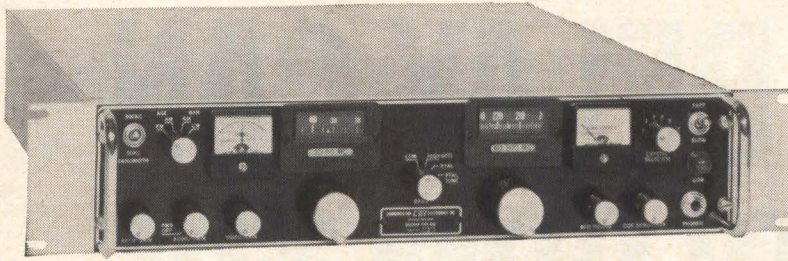

Six Crystal-Controlled Frequencies... Plus Continuous 30-300 MHz Tuning in Two Bands

Meet a new and unusual VHF receiver from CEI. The Type 952 provides AM, FM and CW reception throughout the 30-300 MHz range, while also offering six switch-selectable crystal-controlled frequencies within the 100-150 MHz range.

The receiver's full frequency range is covered in two bands—30-90 MHz and 60-300 MHz—with accurate tuning facilitated by a long steel tape dial. IF bandwidths of 50 and 300 kHz are selectable at the front panel; video and audio outputs are provided from the bandwidth selected, and a built-in BFO operates with either bandwidth when the CW mode is selected.

Sensitivity, stability and operating flexibility are outstanding. For full information about the 952's unusual features and performance, please contact:



COMMUNICATION ELECTRONICS INCORPORATED

6006 Executive Blvd., Rockville, Md. 20852 • Phone: (301) 933-2800 • TWX: 710-824-9603

Circle 251 on reader service card

NEW THERMOCOUPLE REFERENCES WITH 25 CHANNELS ONLY \$259.00!

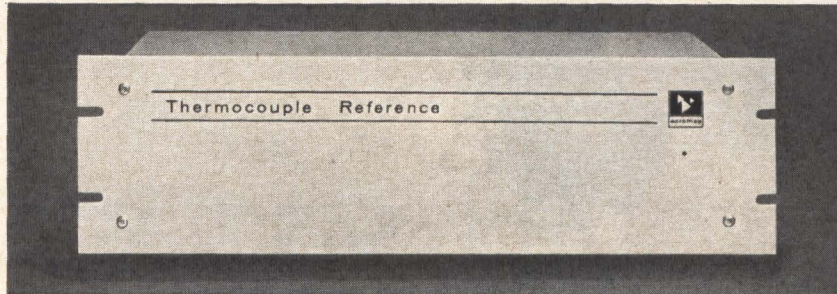

Now — ACROMAG Series 330 Thermocouple References with 25 channels of 0°C ice-point compensation for only \$259.00, including ALL 25 thermocouples! Uniformity 0.05°C, one-second warmup, easy to use. Ideal for scanned TC systems, DDC, and laboratory use. Series 340 References (150°F oven-type) with 25 channels for \$289.00! Both Series stocked in ISA Types, J, K, T, R & S. Others to order.

Request Technical Data 32

ACROMAG INCORPORATED

30765 Wixom Road • Wixom, Michigan 48096
Phone (313) 624-1541

Makers of Precision Instrumentation and Controls



196 Circle 196 on reader service card

New Subassemblies

says the manufacturer, by feeding the voltmeter on the front panel with an operational amplifier. The amplifier's output is also available on rear terminals to permit the connection of a more accurate differential or digital voltmeter, thus increasing the utility of the constant-current supply for component testing and sorting systems.

The CCB supplies have three-position output and meter range switches, a 10-turn output control with resolution to 0.1 microampere, continuously variable voltage limiting, output impedance up to 20,000 megohms, front and rear output terminals, high-speed remote programming, and modulation capability using external a-c source.

Hewlett-Packard, Harrison division, 100 Locust Ave., Berkeley Heights, N.J., 07922. [383]

Plotters operate from digital inputs

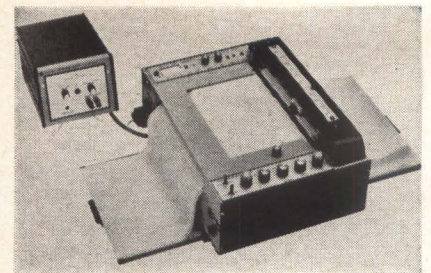

A digital plotting system designated model 6710 operates directly from computers, counters, digital voltmeters, or any source generating parallel binary or BCD data. A 3-decade range of presentation can be made on a 10 in. x 144 ft recording surface with 0.1% resolution. The fan-fold paper can be separated at perforated folds to give 8½ x 11 in. or 11 x 17 in. notebook size records or extended records of unlimited length. All portions of the record may be observed as one would read a book.

The system requires only 1.5 μsec data access as it incorporates a 3-decade single point memory. Command logic and the memory are built into the system allowing operation with computers in the program interrupt mode. A maxi-

Electronics | January 23, 1967

NEW

Lambda high current LK Series power supplies 0-20, 0-36, 0-60 VDC • up to 35 amps • 5¼" height • starting at \$330.

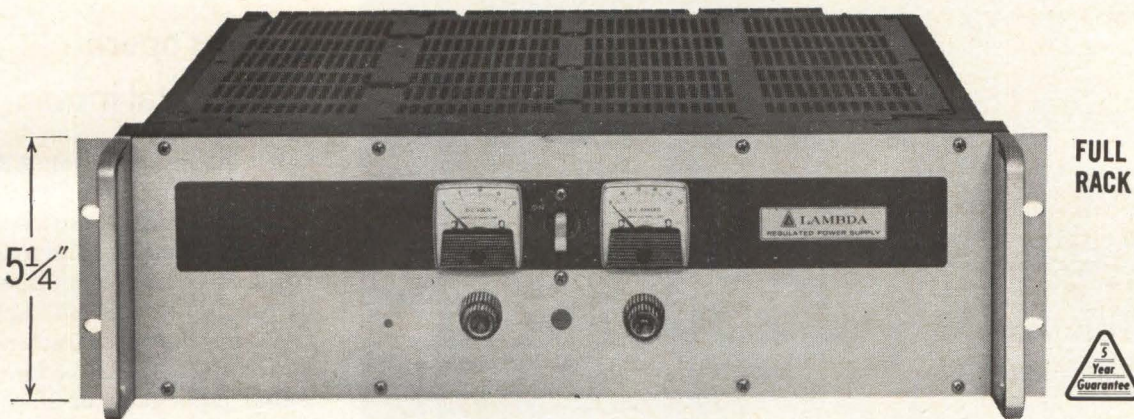

Features

- All Silicon
- Convection cooled
- Remotely programmable
- Meet Mil-Environment specs
Vibration: MIL-T-4807A
Shock: MIL-E-4970A
- Proc. 1 & 2
- Humidity: MIL-STD-810
- Meth. 507
- Temp. Shock: MIL-E-5272C
- (ASG) Proc. 1
- Altitude: MIL-E-4970A
- (ASG) Proc. 1
- Marking: MIL-STD-130
- Quality: MIL-Q-9858
- Remote Sensing

- Series/Parallel Operation
- Regulation—.015% or 1 MV (Line or Load)
- Ripple—500 uV RMS.
- Temp. Coef. .015%/°C
- Transformer—designed to MIL-T-27 Grade 6
- Completely Protected—Short Circuit Proof—Continuously Adjustable Automatic Current Limiting
- Constant I./Constant V. by automatic crossover
- No Voltage Spikes or Overshoot on "turn on, turn off" or power failure
- Wide Input Voltage and Frequency Range—105-132 VAC, 47-63 cps

Rack or Bench use—rubber feet included for bench use.

3 full-rack models—Size 5¼" x 19" x 16½"

Model ²	Voltage Range	CURRENT RANGE AT AMBIENT OF: ¹				Price ²
		40°C	50°C	60°C	71°C	
LK 350	0-20VDC	0-35A	0-31A	0-26A	0-20A	\$675
LK 351	0-36VDC	0-25A	0-23A	0-20A	0-15A	640
LK 352	0-60VDC	0-15A	0-14A	0-12.5A	0-10A	650

6 half-rack models—Size 5¼" x 8⅜" x 16½"

Model ²	Voltage Range	CURRENT RANGE AT AMBIENT OF: ¹				Price ²
		40°C	50°C	60°C	71°C	
LK 340	0-20VDC	0- 8.0A	0- 7.0A	0- 6.1A	0-4.9A	\$330
LK 341	0-20VDC	0-13.5A	0-11.0A	0-10.0A	0-7.7A	385
LK 342	0-36VDC	0- 5.2A	0- 5.0A	0- 4.5A	0-3.7A	335
LK 343	0-36VDC	0- 9.0A	0- 8.5A	0- 7.6A	0-6.1A	395
LK 344	0-60VDC	0- 4.0A	0- 3.5A	0- 3.0A	0-2.5A	340
LK 345	0-60VDC	0- 6.0A	0- 5.2A	0- 4.5A	0-4.0A	395

¹ Current rating applies over entire voltage range.

² Prices are for non-metered models. For metered models add suffix (FM) to model number and add \$30.00 to price.

³ Overvoltage Protection: Add suffix (OV) to model number and add \$70.00 to the price for half-rack models; \$90.00 for full-rack models.



LAMBDA ELECTRONICS CORP.

515 BROAD HOLLOW ROAD • MELVILLE, L. I., NEW YORK • 516 MYRTLE 4-4200

A  SUBSIDIARY

LA-173

YOU'RE
WHISTLING
IN THE
DARK . . .

. . . if you think that heart disease and stroke hit only the other fellow's family. No one is immune. Protect the hearts you love. For authoritative information, ask your Heart Association. For medical advice see your doctor. To safeguard your family . . .

**GIVE...
so more will live
HEART
FUND**



Contributed by the Publisher

New Subassemblies

mum of 1,200 points/minute may be plotted with 0.2% full-scale accuracy.

Price is \$3,725; availability, 45 days after receipt of order.

Houston Omnigraphic Corp., 4950 Terminal Ave., Bellaire, Texas, 77401. [384]

Operational amplifier features low cost

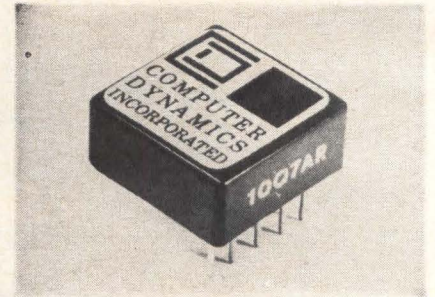

Designed for medium gain and relatively high drift stability, an operational amplifier has been developed that sells for only \$13.50. This is a full service unit with 6 db per octave roll off, low susceptibility to capacitive loading and instant turn-on drift of less than 50 microvolts. It can be used in any application.

Performance characteristics for the model 10Q7AR include a differential input drift of 10 μ v and 0.2 nanoamp per °C. Differential input resistance is 180 kilohms; offset current, less than 25 nanoamps; gain, 90 db; crossover frequency, 2 Mhz; full output frequency, 15 khz; and output, ± 10 v, 2 ma.

Computer Dynamics Inc., 179 Water St., Torrington, Conn., 06791. [385]

Differential amplifier covers wide band

A completely floating, solid state amplifier containing a regulated power supply fulfills all d-c instrumentation amplifier requirements. The model 501 differential d-c amplifier provides 500-v common mode voltage and 120-db isolation.

Other features include stepped and variable gain to 100; noise, 4 μ v; response, 1% from d-c to 5



khz, 1 db to 20 khz and 10-megohm input impedance. Output capabilities are ± 10 v, adjustable between 50 and 150 ma. Output impedance is less than 0.5 ohm. Linearity is 0.05%, and ± 2 -v d-c zero adjust is provided.

The amplifier comes complete with a case suitable for bench use and is priced at \$450 each. Series 103 rack adapter allows 5 amplifiers to be mounted in only $3\frac{1}{2}$ inches of vertical rack height—complete with mating connectors. Instrumentation Amplifiers & Supplies, Inc., 29 Newtown Road, Plainview, N.Y., 11803. [386]

Dual plug-in supplies power for many uses

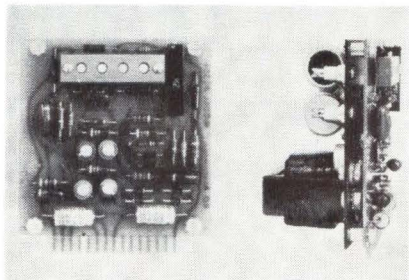

Analog systems, special laboratory or production test setups, and one-time test stations are among the applications for a new dual plug-in power supply. Model 506 features dual, 3-wire output of ± 12 to ± 24 volts d-c at 150 milliamperes for each channel in the compact, plug-in, card-type module design.

Other features include current limit, short circuit protection, and convection cooling over an operating temperature range of -20° to 70° C. Model 506 has regulation of 0.03% line and 0.15% load, and operates at 45 to 440 hertz, 105 to 130 v a-c input.

The unit is $2\frac{1}{2} \times 3\frac{1}{2} \times 3\frac{3}{4}$ in. RO Associates Inc., 917 Terminal Way, San Carlos, Calif., 94070. [387]



At left, Spectra-Physics Model 140 argon laser. Above, ion laser beam photographed through a Fabry-Perot interferometer.

How to sell your boss on getting you a Model 140 Ion Laser

Tell him it's put together the way a precision scientific instrument should be, with superior mechanical and electrical integrity, backed by a full-year, no-strings warranty.

Tell him it has a power density capability of a billion watts per square inch, yet costs less per watt than any other ion laser of comparable quality. Tell him it's the only *induction* ion laser, and explain that this means no metal cathodes to burn out in the plasma tube, giving you low-noise optical output with much greater plasma tube reliability.

Tell him about Dial-a-Color tuning, which uses an intra-cavity Littrow prism to give you any one of eight wavelengths from yellow to blue, shown on the calibrated slide rule dial. Tell him you can also get the Model 140 with an interchangeable non-prism reflector, permitting all argon transitions to operate simultaneously, resulting in maximum power output.

And tell him, if your application idea is one that requires the ion laser itself to determine its feasibility, we can perhaps arrange for you to experiment with a Model 140 we've set aside for that purpose.

If he hasn't given you a thumbs-up by this time, tell him the Model 140 is made by Spectra-Physics. That should do the trick.

If you'd like to be armed with a data sheet before you tackle your boss, write us at 1255 Terra Bella, Mountain View, California 94040. In Europe, Spectra-Physics, S.A., 18, rue Saint-Pierre, Box 142, 1701 Fribourg, Switzerland.



Spectra-Physics

BIFILAR THE NEW TWIST IN RELAYS!

Of course Bifilar coil winding is no dramatic new story. But a relay with a counter EMF of 50 volts max is! We've gotten rid of all diodes and bulky shielding tricks, so the relay package is still the same small standard size.

Most importantly, our method doesn't suppress transient voltage at the expense of relay parameters, or increase temperature past recommended maximums, or affect contact resistance. Reliability's up because Bifilar isn't polarity sensitive and doesn't use additional components.

Still as tough? How about shock of 50G, 11 ms and vibration standards like 30G @ 3000 cps on a Bifilar half size crystal can. Good enough?

Then you'll be glad to know that Bifilar relays are now shipping in sub-miniature Series E, as well as husky 20-amp 3PST/NO 9324 power contactors.

Call Leach Corporation, Relay Division (213) 232-8221. Mail takes a little longer. 5915 South Avalon Bl., Los Angeles, Calif. 90003. Export . . . Leach International S. A.

LEACH

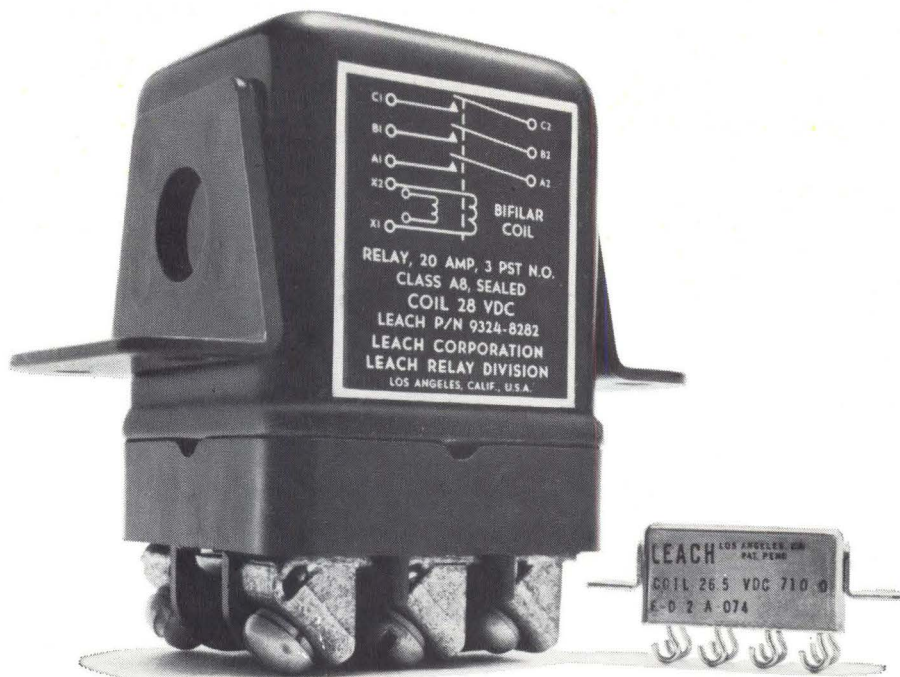



Ball .002" dia., Iteration $\pm 5\%$

TEMPRESS HYDROGEN FLAME-OFF TORCHES FOR LEAD-BONDING MACHINES ARE STAINLESS STEEL, WITH SAPPHIRE ORIFICE INSERTS that maintain size and shape accuracy of the 2166°C hydrogen flame. The highly polished inner surface of the sapphire insert assures this by eliminating gas turbulence and a resultant distortion of the flame. The end result is essentially identical gold balls on every lead, from start to finish of a production run. 14X magnification of operation shows flame-off torch at left, with orifice partially visible. Gold wire, with perfectly formed ball, protrudes from Tempress tungsten

carbide capillary tube, ready for next bonding cycle. This extreme precision symbolizes the Tempress approach to every project... explains why it requires 11 months to train an operator for many Tempress production operations. Other Tempress products include automatic scribing machines, diamond scribes, diamond lapping points, and tungsten carbide probe contact needles.

Lead-bonding, Model DTN-1, at Union Carbide Electronics.



TEMPRESS

Tempress Research Co., 566 San Xavier Ave., Sunnyvale, Calif.

Circle 201 on reader service card

select from the most complete line of relay rack panels on the market

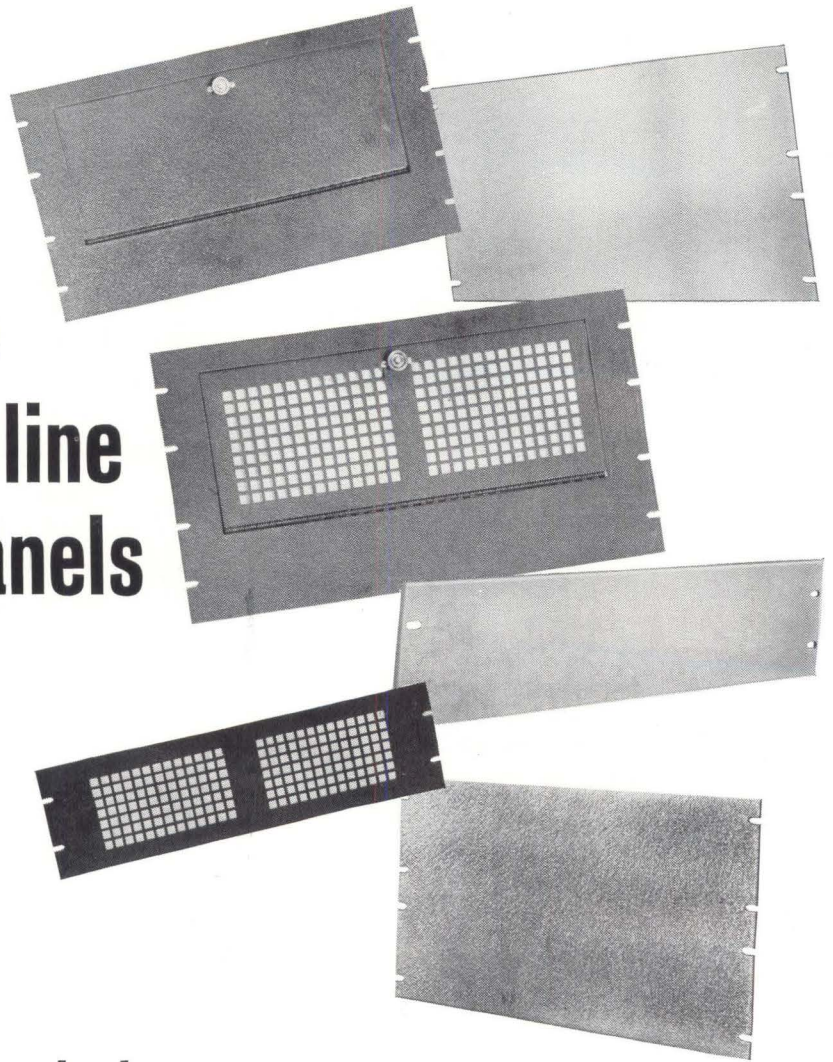

BUD makes

**141 different types and sizes
...in a choice of seven finishes
...all delivered from stock**

What do you look for in a relay rack panel . . . steel or aluminum . . . wide choice of sizes . . . good selection of finishes . . . immediate delivery!

Our huge production facilities enable us to meet your requirements promptly . . . smaller quantities from our distributors' stock — larger quantities from our plant.

If a stock panel doesn't exactly suit your needs, our special services include custom punching, color matching and silk screening.

See all the Bud relay rack panels at any one of 400 Authorized Bud Distributors.

Write us for Bulletin PA 67 which gives complete information about our complete line of relay rack panels.



BUD RADIO, INC.

4611 E. 355th Street • Willoughby, Ohio 44094

New Microwave

Swept analyzer costs under \$10,000

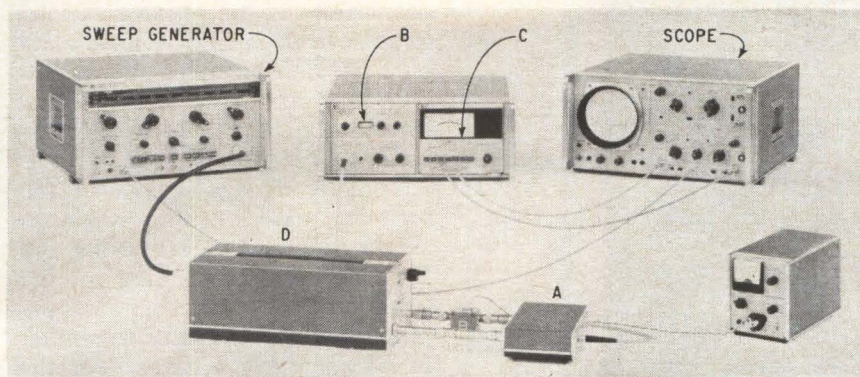

A swept-frequency network analyzer costing but a fraction of that of comparable wideband units, according to its maker, accurately measures a signal's phase and amplitude. Such information is essential in designing microwave components, amplifiers and antenna arrays, and in analyzing circuit constants such as "S" parameters. An external sweep generator sweeps the system in octave bands from 0.11 to 12.4 gigahertz.

The analyzer can perform in minutes measurements that take hours with conventional slotted line techniques.

The manufacturer, the Hewlett-Packard Co., offers the analyzer, with accessories, for less than \$10,000. This equals the cost of previous systems that measure only amplitude, says H-P, and is a fifth the cost of other swept-frequency measuring systems with a similar frequency range. It's faster, measures easier and is smaller than all predecessors, the company says.

The analyzer consists basically of a frequency converter, A; a network analyzer mainframe, B; and two types of plug-in units, such as C, that provide different displays. The plug-in shown, model 8413A, displays phase and amplitude on a meter and supplies output signals for display on a conventional oscilloscope. The alternate plug-in, model 8414A, allows Smith chart analysis by presenting the information in polar coordinates on a cathode-ray tube. Precision calibrated line stretchers in accessory

D, model 8740A, split the swept-frequency signal. The transmission unit also changes the reference plane to facilitate analysis of the impedance or admittance of the circuits being tested.

Amplitude is resolved to 0.1 decibel and phase is resolved to 0.1° at any angle to 360° . Phase lead and lag are clearly indicated. Swept measurements can be made of components that have an amplitude variation of 60 db.

In measuring, the output of a sweep or signal generator is split into two parts. One part serves as a reference for phase and amplitude and the other serves as a test signal that interacts with a component or circuit being measured. The transmission unit, D, can perform this split or conventional precision hardware can be used.

Reference and test signals are fed into the frequency converter, which is the main element of the analyzer. The converter, model 8411A, is a wideband, phase-locked unit that heterodynes the inputs down to two 20-megahertz signals that are coherently related in phase and amplitude to the microwave signals.

These 20-Mhz signals when fed into a plug-in, such as C, are converted to 277.7 kilohertz, allowing all measurements to be made with precision low-frequency components. Since 277.7 is inversely related to 360, a time interval counter can relate the period of the signal directly to degrees.

The phase lock loop in the converter maintains the 20-Mhz fre-

THE HULL STORY...
ENCAPSULATION
BY TRANSFER MOLDING

For components
like these...

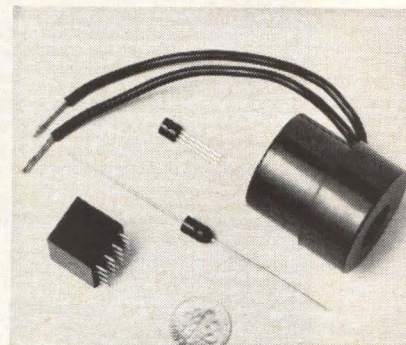

why do the world's
leading manufacturers*
depend on Hull
packaged systems?

Here's why:

RECOMMENDATIONS BASED UPON OVER 500 INSTALLATIONS—Since 1956, Hull has accumulated a wealth of encapsulation know-how to guide selection of the right production equipment.

UNDIVIDED SYSTEM RESPONSIBILITY—The Hull "package" includes press, molds, loading frames, and auxiliary handling equipment . . . assuring smooth, economical flow of production parts.

INTO PRODUCTION, FASTER, SURER—Hull can help steer system design for optimum encapsulation while product is at "bread-board" stage . . . minimizing lost motion and delays.

LOW-COST, QUALITY PRODUCT ASSURED—Hull encapsulation systems offer a proven method for rapid, precise, and economical packaging of electronic components and circuits, large or small.

FOR MORE OF THE HULL STORY on encapsulation by transfer molding, write for a copy of Bulletin P963. **HULL CORPORATION**, 7031 Davisville Road, Hatboro, Pa. 19040. Telephone: (215) 675-5000. Export: 1505 Race St., Phila., Pa. 19102.

*Texas Instruments, General Electric, IBM, Motorola, Philips, Fairchild Semiconductor, Siemens & Halske—to name a few.

Visit Us at NEP/CON West Booth 708



H-38

**Inel 1967
3rd International
Exhibition
of Industrial
Electronics**

**14-18 November
in the halls
of the Swiss
Industries Fair
Basel
Switzerland**



**Inel 1967
an even
greater success
with its
new enlarged
program**

**Information and
documentation
Secretariat INEL
CH-4000 Basel 21
Switzerland
Phone 061- 32 38 50
Telex 62 685 fairs basel**

New Microwave

quency output even when the source is very rapidly swept. H-P accomplished this by optimizing all parameters in the phase lock loop to achieve an equivalent bandwidth of 2 to 3 Mhz. This allows the converter to follow a signal that sweeps 4 gigahertz in 10 milliseconds.

To heterodyne, a high-speed step recovery diode in the converter serves as a driver for a high-speed Schottky barrier diode that samples the microwave frequency. The sampling diode, which turns on and off in 30 picoseconds, was specially designed for the unit; but is also used in an X-band oscilloscope that H-P introduced last year. The diode is not for sale, the company says.

Prices

Basic analyzer	
Frequency converter, 8411A	\$2,200
Network analyzer mainframe, 8410A	\$1,700
Plug-in, 8413A	\$825
Plug-in, 8414A	\$825
Accessories	
Transmission test unit, 8740A	\$1,100
Reflection test unit, 8741A (0.11 to 2 Ghz)	Less than \$1,500
Reflection test unit, 8742A (2 to 12.4 Ghz)	Less than \$1,500

Hewlett-Packard Co., 1501 Page Mill Road, Palo Alto, Calif. [391]

S-band, high power digital phase shifter

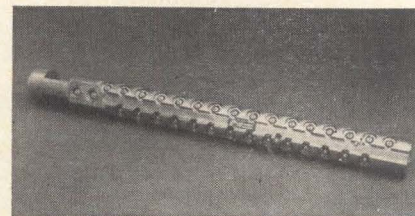

A compact digital phase shifter, the MA-8357-8S1E, is designed for phased array applications. An array of these devices is capable of replacing conventional electromechanically driven antennas.

The unit features reciprocal operation and high power capability at 15 kw peak and 500 w average

operating power levels with a burn-out level in excess of 30 kw. Particular emphasis has been placed on its ability to maintain phase accuracy at $\pm 3^\circ$ for all phase combinations from a nominal characteristic. Bandwidth is 10% within any 2 to 4 GHz range.

P-i-n diodes are mounted in iterative fashion in the phase shifter and are switched in combinations which provide a maximum of 360° of phase shift in a minimum of 22.5° increments. Insertion loss is 2 db maximum and 1.5 db average; vswr, 1.35:1 maximum and 1.15:1 average. Lightweight, compact construction has resulted in a package 21 in. long x 2 in. diameter and 5 lbs in weight. Microwave Associates, Burlington, Mass. [392]

Mixer/preamplifiers come in 7 models

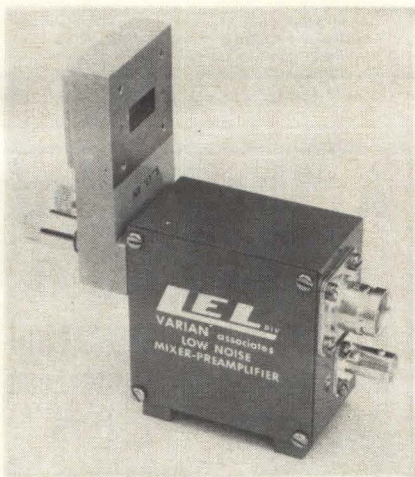

A compact series of waveguide-input mixer/preamplifiers makes use of low-noise wideband, orthogonal-mode waveguide mixers. Seven models encompass the frequency range of 5.4 to 39 GHz.

Typical is the XDB-7 with input-frequency range of 8.2 to 12.4 GHz; intermediate frequencies, 30, 60 or 70 GHz; noise figure, 9 to 10 db; local oscillator required, 2 mw; power requirement, -20 v d-c, 10 ma.

A choice of i-f bandwidths, 12 or 20 Mhz, is offered. Conversion gain is 24 db for the 12 Mhz bandwidth; 19 db in the 20 Mhz bandwidth. The mixer/preamplifier has a signal-handling capability of -24

Biggest cermet value at lowest prices!

Here is the lowest priced cermet trimmer you can buy in an RJ11 package! Even if the Spectrol design was not better (and we think it is) could you afford to ignore the prices?

1-9	\$3.10	250-499	\$2.10
25-99	\$2.45	LARGER QUANTITIES	
100-249	\$2.30	AS LOW AS	\$1.74

And at these prices, what other non-wirewound can beat these specs?

- Resistance Range: 100 Ω to 1 megohm.
- Power Rating: 0.75W @ 70°C.
- Temperature Range: -25°C. to +125°C.
- Resistance Tolerance: $\pm 20\%$
- Tempco: ± 300 ppm/ $^\circ$ C. max.
- Element: Cermet
- Packages: RJ11 size with 5 mounting options

But the proof is in the product. You'll find it on the shelves of your local Spectrol distributor. Its performance will prove to you that our published specs are conservative. (We like it that way.)



Better Components for Better Systems

SPECTROL ELECTRONICS CORPORATION / 17070 E. GALE AVENUE, CITY OF INDUSTRY, CALIFORNIA 91745 / PHONE: (213) 964-6565 • TWX: (910) 584-1314

SPECTROL
949-2-1-202 2K 6E99

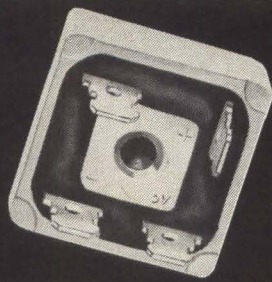

"ALPAC" A NEW CONCEPT!

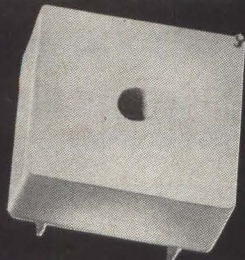

high current integrated rectifier circuits

"ALPAC" bridge rectifier circuits offer:
ALUMINUM CASE — A new power bridge rectifier circuit designed in a functional aluminum case.

HIGH CURRENT — Up to 25 amps average rectified current available from PIV ratings of 50 to 600 volts.

SMALL SIZE — Case size is 1.125"x1.125" x.406" max.

TERMINALS INSULATED FROM CASE — Unique 3-way-universal-terminals allow maximum installation flexibility.

"ALPAC" is specifically designed to simplify packaging and minimizing production costs. Economically priced to replace multiple stud rectifier usage, "ALPAC" reduces space requirements by one third with improved reliability.

Internally, "ALPAC" utilizes the Semtech high performance rectifiers, welded together for mechanical strength. The device is rated at a maximum thermal resistance of 1.5°C/Watt.

Technical bulletins describing the "ALPAC" high current Bridge Rectifiers, Doublers, and Center Taps are available.

SEMTECH CORPORATION

WESTERN OFFICE: 652 Mitchell Road, Newbury Park, California
(805) 498-2111 (213) 628-5392/TWX 805-499-7137
Central: 140 No. La Grange Road, La Grange, Ill. (312) 352-3227
Eastern: 71 West 23rd St. N.Y., (212) 989-7550/TWX 212-640-5060
European Sales: Bourns AG, Alpenstrasse 1,
6301 Zug, Switzerland (042) 4 82 72/73

New Microwave

dbm, with less than 1 db of compression.

Price is \$995; delivery, one month.
LEL division, Varian Associates, Akron St., Copiague, N.Y., 11726. [393]

B-w amplifier tube operates in S band

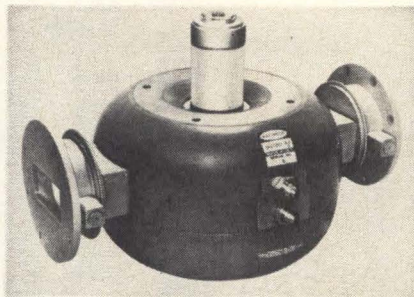

Combination of a 16-db gain at 2.9 to 3.1 Ghz with 60 kw peak power is featured in an S-band backward-wave amplifier tube. The model QKS1267 amplifier retains the compactness, high efficiency and low voltage features of standard bwa's.

Average powers up to 3 kw are available. Nominal efficiency is 70% and anode voltage is 25 kv. The unit has a pulse width of 30 or more μ sec. Weight is under 50 lbs.

Raytheon Co., Microwave and Power Tube division, Waltham, Mass., 02154. [394]

Turret attenuators feature high accuracy

A line of coaxial step-attenuators provide 60-db attenuation in 10-db steps at any frequency from d-c to 12.4 Ghz. The accuracy of the steps is ± 1.0 db, which includes any variations due to frequency.

Series TA-700 turret attenuators, suited for use in both production line and laboratory test equipment, remain unaffected by major changes in frequency. Frequency sensitivity is less than 0.3 db per octave. Measuring only 2 1/4 x 2 1/4 x 2 1/2 in., the attenuators have 1.5 vswr at both input and output ports

Business Opportunities

Leading FRENCH manufacturer of radio and T.V. sets branching out into the professional field would be interested in securing

Representations

from leading American electronics firms in

- 1- MEASURING INSTRUMENTS & INSTRUMENTATION
- 2- SYSTEMS (Data, processing, control...)
- 3- CRYOGENICS AND OPTICS
- 4- AMPLIFIERS FOR I.R. DETECTION
- 5- CAMERA RECORDERS AND / OR RECORDER REPRODUCERS
- 6- BIO-TRANSDUCERS AND MEDICAL INSTRUMENTATION

Possibility of manufacturing under license agreement.

Address your reply :

PIZON BROS

18, rue de la Félicité
PARIS 17^e - France

P.S. We intend to participate in MESUCORA, an international show of Measuring Instruments to be held in Paris in the Spring. We would be glad to feature YOUR products.

Circle 254 on reader service card

A "Wealth" of Helpful Data

NO COST NO OBLIGATION
Ask for it on your letterhead

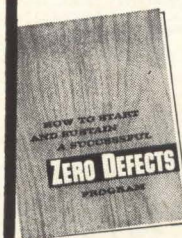

ZERO DEFECTS KIT

Includes:

- Detailed Program Time Table
- Special Reports on Zero Defects
- Procedure Plans for Organizing and Implementing a Program
- Error Cause Removal Plan
- Actual Multi-Colored Motivation Posters (17" x 22")
- Auto Bumper Sticker
- Pledge Card
- Zero Defects Emblematic Jewelry Catalogue
- Details on 35mm Filmstrip

This valuable kit is yours without obligation. Write on your company letterhead today.

ELLIOTT SERVICE COMPANY, INC.
Dept. ZD, 30 N. MacQuisten Parkway
Mount Vernon, New York 10550

Circle 262 on reader service card

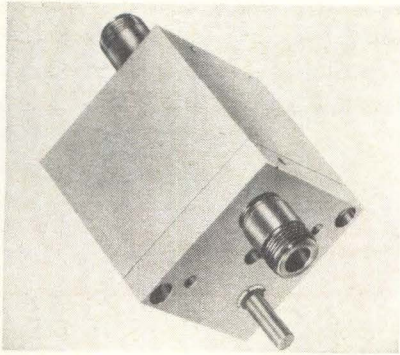

and a 1 db maximum insertion loss over the entire frequency range. The units can handle 2 watts average and 1 kw peak power. Connectors are type N, stainless steel, designed to meet the requirements of MIL-C-39012.

Filmohm Corp., 48 W. 25th St., New York, N.Y., 10010. [395]

Co-ax transfer switch maintains low vswr

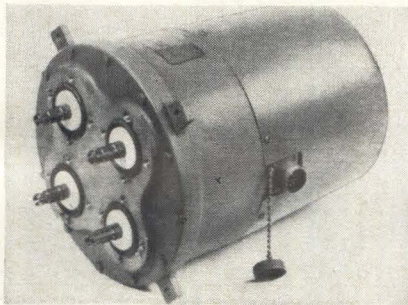

Versatility of operation is featured in a 1 $\frac{5}{8}$ in. coaxial transfer switch designed for frequencies up to 2.9 Ghz. The 50-ohm switch has applications wherever r-f power must be rerouted quickly and reliably such as in industrial and military communications systems or in radio and tv broadcast stations.

The transfer switch, which is motor driven, maintains a vswr of less than 1.05 up to 2.9 Ghz, and has an average capability of 15 kw at 100 Mhz. It can be cycled manually in case of a-c power failure.

Type 6732 requires fewer units than spdt switches that perform similar switching functions. It provides two completely independent interlock circuits which follow the r-f path, opening and closing as the r-f contacts open and close. Contacts that indicate switch position are also included.

Andrew Corp., Box 807, Chicago, Ill., 60642. [396]

EDGEWISE PANEL METERS

...we've got your number

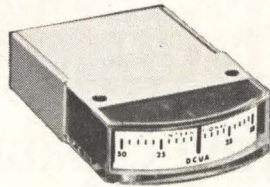

I122 flat, stackable, self-shielding; 1.24" scale in less than a square inch of panel.

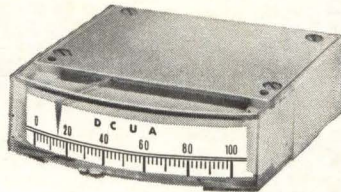

I136 scale length (2") of a 3 $\frac{1}{2}$ " conventional meter in a stackable, 2.6" wide edgewise. Easy to read, too: bi-level scale, optional internal illumination.

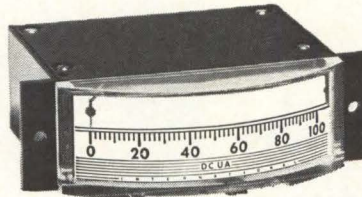

I145 2.7" scale, bi-level, for easy reading. A completely shielded, 3 $\frac{1}{2}$ " stackable meter, ideal where you need a bigger readout.

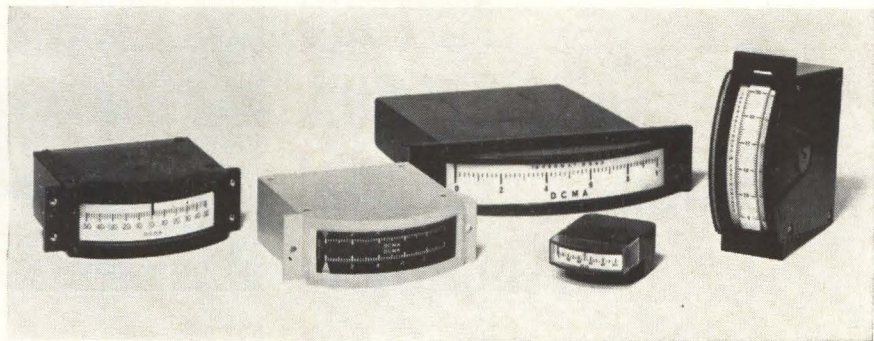

I147, 2520, 2150, I120, 2500 military models, dual-scale meters, 5" scales, economy versions, meters with interchangeable scales, specials to order.

The move is on to edgewise. Equipment designers everywhere are realizing that edgewise meters give as much as three times the scale readout as conventional meters in the same panel space.

We're the leaders in edgewise meters, have been since we pioneered the concept years ago. Now we offer industry's broadest line of up-to-date, space-saving edgewise models. Our new edgewise catalog, Bulletin 391, has all the details. Write for a copy.



international instruments inc.

8703 Marsh Hill Road • Orange, Connecticut 06477

Is your problem

INTEGRATED OPERATIONAL AMPLIFIERS-

output current carrying capability,
input offset voltage,
input bias current?

Here's the
NSC answer!
NS7560
and NS7560A
Integrated Operational
Amplifiers

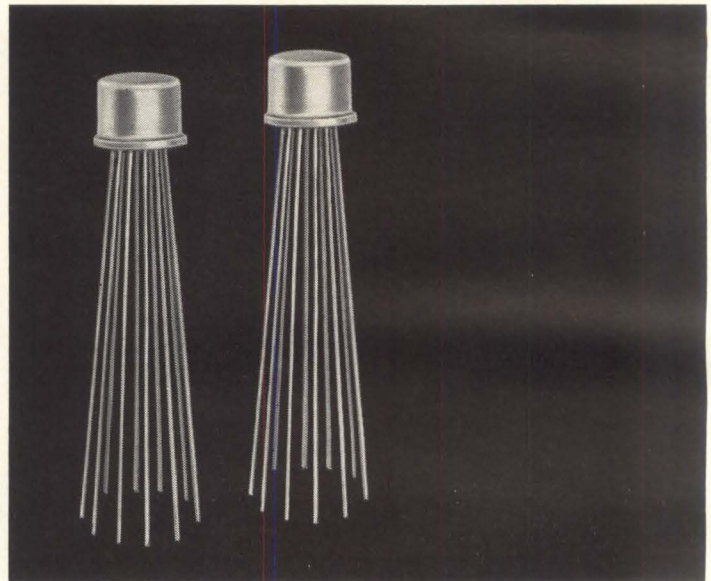

Features: • low input currents • low differential input currents • high output current capability • low input offset voltages • low standby power • TO-5 package.

100 LOT PRICE

NS7560 \$17.50 NS7560A \$35.00

SPECIFICATIONS	NS 7560	NS 7560A
Input Offset Voltage (Maximum)	10 mv	3 mv
Input Offset Voltage Temperature Coefficient (Maximum)	30 μ v/ $^{\circ}$ C	15 μ v/ $^{\circ}$ C
Input Bias Current (Maximum)	100 na	25 na
Differential Input Current (Maximum)	50 na	2 na
Input Bias Current Temperature Coefficient (Maximum)	2 na/ $^{\circ}$ C	1 na/ $^{\circ}$ C
Peak Output Current (Maximum)	\pm 50 ma	\pm 50 ma

NSC
NATIONAL SEMICONDUCTOR CORPORATION, DANBURY, CONN.
(203) 744-0060

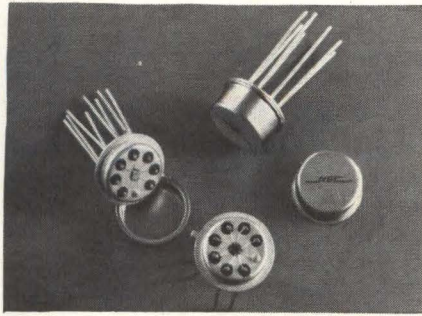

Available from your

NSC
distributor

WESTERN DISTRIBUTORS:

Moltronics of Arizona
2746 West Palm Lane
Phoenix, Arizona 85009
(602) 272-7951

Fortune Electronics
695 Veterans Blvd.
Redwood City, California 94063
(415) 365-4000

Kierulff Electronics
3969 East Bayshore Road
Palo Alto, California 94303
(415) 968-6292

Arco Pacific
Bohamon Drive
Menlo Park, Calif. 94025
(415) 324-1356

Liberty Electronics Corp.
339 South Isis Avenue
Inglewood, California
(213) 678-8111

Spectronics
131 Garnet
Ridgecrest, California 93555
(714) 378-2831

Western Electronic Components
4301 Birch St.
Newport Beach, California
(714) 540-1322
(213) 631-6119

Newark-Denver Electronics Supply
P. O. Box 22045
Denver, Colorado
(303) 757-3351

Pacific Electronics
1336-4 Dillingham Blvd.
Honolulu, Hawaii 96817
817-118

Sterling Electronics, Inc.
1712 Lomas Blvd., N.E.
Albuquerque, New Mexico
(505) 247-2486

Kierulff Electronics
2585 Commerce Way
Los Angeles, California 90022
(213) 685-5511

Ballard Supply Company
3109 Washington Blvd.
Ogden, Utah 84400
(801) 394-5541

Ballard Supply Company
44 East 6th Street, South
Salt Lake City, Utah 84100
(801) 364-6541

Kierulff Electronics
6133 Maynard Ave., S.
Seattle, Wash. 98108
(206) PA 5-1550

Kierulff Electronics
8137 Engineer Road
San Diego, California
(714) 278-2112

New Production Equipment

Peg tip solders miniature assemblies

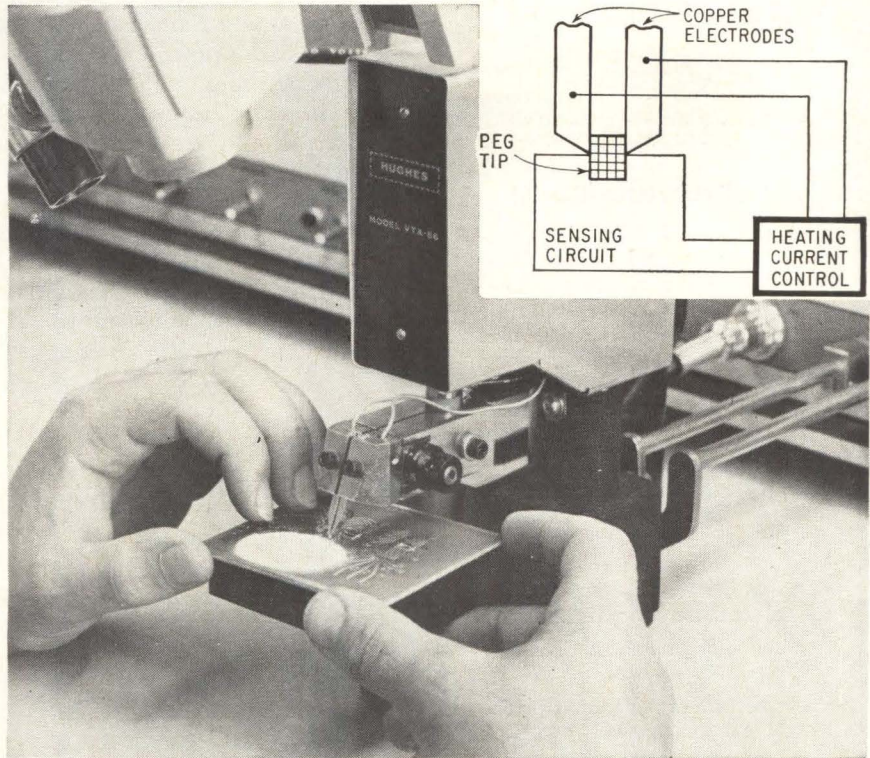

Parallel-gap electrodes plugged with a peg tip are joining the family of tools used to bond ultra-miniature assemblies by the solder reflow method. The developer, the Hughes Aircraft Co.'s production equipment department, claims the new electrodes will replace the unplugged type in most applications because:

- Leads don't have to be stripped before the soldering operation as in parallel-gap soldering. The peg tip melts right through the insulation.
- Current doesn't pass through the parts being soldered and there is no buildup of flux on the soldering electrodes. Thus, they require little cleaning.
- The shape of the peg tip makes it possible to solder parts regardless of their orientation.

In addition, a minimum of heat is transferred to adjacent parts or to previously soldered areas, according to Hughes, and there is little damage to or delamination of printed circuit pads.

The peg tip is 35 mils in diameter and is placed between the two

copper electrodes. The tip is cool when held to the work before the solder cycle begins. A pulse of heating current is then applied and the tip holds the work in place while the solder flows and hardens. No current flows in the work itself.

Applications include terminating wire matrixes in memory planes, attaching discrete components in hybrid thin-film circuits and soldering to small coils and transformers. The system effectively solders round wire up to 20 mils in diameter.

The peg tip—actually a molybdenum short between the electrodes—is heated by conduction. A voltage pickup across the tip monitors its resistance every 25 microseconds and feeds this information back to a transistorized power supply. Controlled amounts of current are fed into the tip to hold its temperature constant.

The operator of the unit can vary both the amplitude of the heating pulse and its length before he begins soldering. Pulse length can range from one millisecond to 9.9

from a master coordinate optical scale. At each precise location a signal is generated for image placement. This arrangement, coupled with both the sensing scanner and reduction camera fixed coaxially, assures that image locations are always an exact reproduction of the master optical scale.

Standard rate of continuous image placement is 4 in. per minute. Faster rates are possible depending on the rate of recovery of the light source being utilized. The 4M-10AX will accept photo plates 2 x 2 in., 2½ x 2½ in. and 4 x 5 in., and can be easily and quickly adapted to other sizes.

Images may be changed within an array by a new off-stage aligning feature without detectable loss in accuracy. An optional programing console for image omission within an array is also available. This is a desirable feature when an array is to be composed of two or more images.

The generation of each step-and-repeat plate is accomplished by rescanning the master. Continuous repeatability is, therefore, assured. The Jade Corp., Bethayres, Pa., 19006. [402]

Processing machines for p-c boards

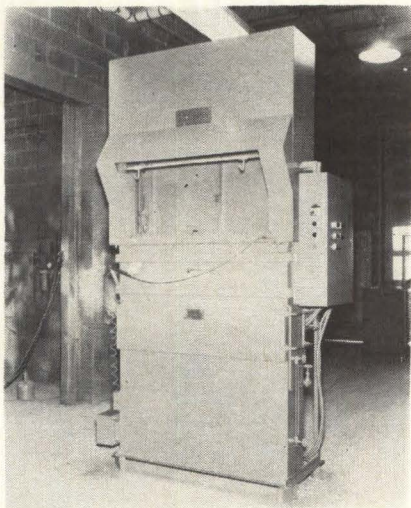

There's a choice of ways to clean and develop printed-circuit boards with a new series of printed-circuit processing machines. The machines offer either manual or conveyor operation and feature a choice of immersion-vapor, vapor-

CUT CONSTRUCTION DELAY

with pre-punched -
VECTORBORD,*
PLUGBORDS and
Push-in TERMINALS

Make circuits the fast, easy way . . . simply insert Vector push-in terminals (wide variety available) and component wires into pre-punched Vectorbord, or use punched copper clad for do-it-yourself etching; and, for production, we're geared to omit the holes not required and assemble terminals, eyelets, etc. to your specifications. Eleven patterns available with .025", .040", .062", .093" holes in XXXP phenolic, glass silicone, glass or paper epoxy and copper clad. Plugboards supplied in many sizes with etched pads, .040" dia. Edge-Pins or Elco Varicon® contacts.

Save time — Save work — Save money!

TRADE MARK

Send for complete literature
VECTOR ELECTRONIC CO., INC.
 1100 Flower St., Glendale, Calif. 91201 Area 213 Phone 245-8971
 Circle 253 on reader service card

CONOLIDATED AVIONICS

POWER SUPPLIES

UNCONDITIONALLY GUARANTEED FOR FIVE YEARS

NOW AVAILABLE

Consolidated Avionics' handbook provides you with comprehensive data on the largest available line of dc power supplies for systems. Prices are included in the booklet, as well as a unique new **CONSOLIDATED AVIONICS** chart for determining heat sink requirements. A DIVISION OF **CONDEC** CORPORATION

800 Shames Drive/Westbury, L.I., N.Y. (516) ED 4-8400/TWX: 510-222-6151

digital systems

opportunities at NCR electronics division in los angeles

SYSTEMS FORMULATION & ANALYSIS ENGINEERS

For assignments in commercial on-line computer applications with emphasis on communications interface. Extensive experience required in hardware specifications and advanced systems, including multiprogramming and list processing. Requires B.S. in engineering, business or related field.

SOFTWARE PROGRAMMER

DIAGNOSTIC PROGRAMMER

PROJECT ENGINEERS

Computing Systems
Peripheral Equipment
Discs & Controllers
Packaging

CIRCUIT DESIGN ENGINEERS

ELECTRICAL & MECHANICAL LIAISON ENGINEERS

PACKAGING ENGINEERS (ALL LEVELS)

MECHANICAL DEVELOPMENT ENGINEER

RELIABILITY ENGINEERS

QUALITY CONTROL ENGINEERS

PROCESS ENGINEER—ELECTRONIC

TEST EQUIPMENT DESIGN ENGINEERS

MEMORY DESIGN—RESEARCH

ARRANGE NOW FOR AN INTERVIEW IN YOUR AREA

Confidential interviews will be held soon in various parts of the country. To arrange an appointment, please send your resume, including experience, training and salary history, to Bill Holloway, Technical Placement.

The National Cash Register Company

NCR

ELECTRONICS DIVISION
2816 W. El Segundo Blvd., Hawthorne, Calif.
Telephone: Area Code (213) 757-5111
An equal-opportunity employer

Production Equipment

spray-vapor or immersion-spray-vapor cycles. Solvents such as Freon TMC for flux removal and trichloroethylene for developing KOR and KPR photoresist can be used.

Long, narrow top openings in the processors match the configuration of p-c boards. This minimizes machine height and insures low solvent consumption.

The manually operated models are normally used for low and medium production rates where process timing and sequencing are not critical. Where high production rates are involved or where process sequence and timing are critical, a conveyORIZED version with a program control is added to the manually operated machine.

Conveyor installation can be accomplished at manufacture or in the customer's plant with a "drop-in" conveyor and associated program control. A feature of the conveyORIZED machine is the oscillation of the boards in the immersion and spray which yields uniform cleaning or developing.

Standard units are available which can process individual boards or combinations with maximum dimensions ranging from 36x15 in. to 72x15 in. Custom machines are available with a stainless steel enclosure for white room installations.

Prices for the SLC series range from \$2,000 to \$6,900 depending on size, conveyORIZATION and program control.

Branson Equipment Co., 51 Terminal Ave., Clark, N.J. [403]

Cable stripper severs instantly

Metal braid shielding on coaxial cable and thermocouple wire can be stripped cleanly by melting the shielding with an electric current.

Two electrodes, 1/16 in. apart in the MSS-205 Blue Arc stripper, grip opposite sides of the braid. Low-voltage current is then sent through the gap to sever the braid in much the same way as when a fuse is blown.

At the point of severance the braid ends are fused so there is no

MICO

NEW MODEL 885 SEVEN RATIO WIDE-RANGE ENGRAVER

NO. 885

FOR LONG AND MULTI-LINE WORK

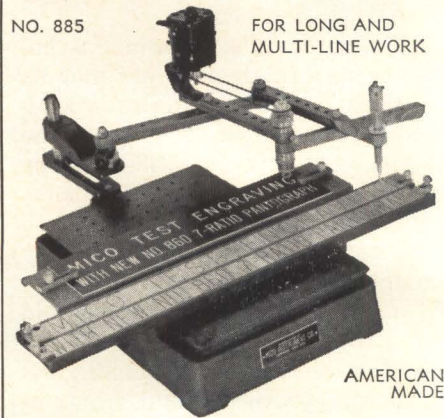

- A time-saver for large plate work.
- Engraves 3" x 19" area in one set-up.
- Seven pantograph ratios—from 1:5:1 to 6:1.
- Choice of 3-ball-bearing spindle assemblies for 1/8", 3/16" or taper-shank cutters.
- HSS, COBALT and Solid Carbide Cutters.
- Single and multi-line copy carriers for holding, blanks 3/4" to 3 1/2" high.
- Accommodates Mico standard accessories.

Send for bulletins and prices

MICO INSTRUMENT CO.

77 Trowbridge St. Cambridge, Mass. 02138

Circle 256 on reader service card

SanRex

THYRISTORS



20 AMPS SERIES

Up to PRV 600V

70 AMPS SERIES

Up to PRV 800V



For full details Contact
SANSHA ELECTRIC TRADING CO., LTD.
P.O. BOX CENTRAL 946, OSAKA, JAPAN



Great editorial
is something
he takes home

(What a climate for selling!)

Electronics

A McGraw-Hill Market-Directed Publication
330 West 42nd Street, New York, N.Y. 10036



VERSATILE, EASY-TO-USE SELECTOR SWITCH

Provides fast
rail freight yard
classification control

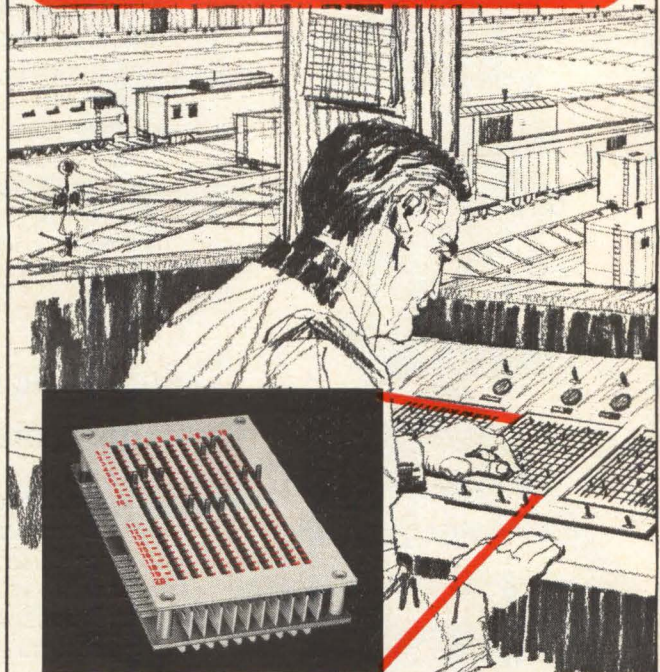

New Cherry Selector Switch enables operator to control freight yard traffic with speed and accuracy

Now—a manual switching device, human-engineered for rapid finger-tip selection of cars, track locations and sequence classification of trains—with continuous visual reference.

The Cherry Selector Switch can be installed *quickly* because no soldering is required. And there's no jungle of wires to confuse you or cause problems. It is available in various sizes—from 100 to 2784 positions. **Write today for full details.**

CHERRY

ELECTRICAL
PRODUCTS CORP.

1656 Old Deerfield Road

Highland Park, Illinois 60035

IC's, MODULES, COMPONENTS
& OTHER MULTI-LEAD SOLID
STATE DEVICES

NOW YOU CAN AUTOMATE

- Quality Assurance
- Incoming Inspection
- Production Test

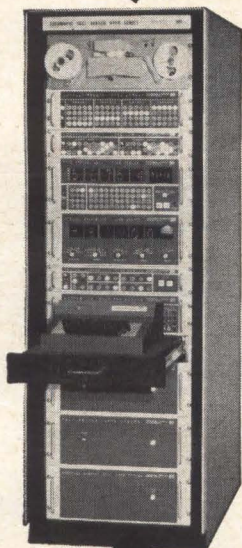

...with the Auto Data 9400 Automatic Test System from

3M High speed GO/NO-GO comparisons, as well as DC, AC and resistance measurements, can be performed economically and reliably with the model 9400 system. Modular construction techniques are used throughout the system to provide off-the-shelf availability with "custom design" versatility. Complete provisions are included in the 9400 Series for logging, handling, and classifying. Economical and easy to use punched tape is provided for ease of programming and fast program change to satisfy small or large volume testing.

Write for detailed specifications.

Instrument Products **3M**
COMPANY

300 SOUTH LEWIS ROAD • CAMARILLO, CALIFORNIA 93010
PHONE: (805) 482-1911 • TWX: 510-866-7099

Production Equipment

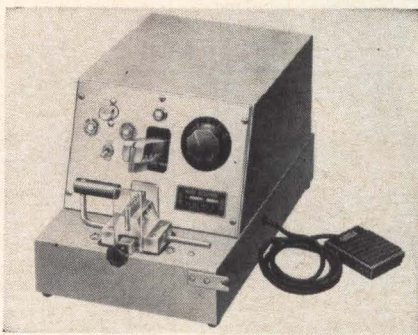

fraying. A grounded wire or pigtail may be welded to the braid by placing the wire between the electrodes for simultaneous fusing and severing. The electrodes are closed pneumatically by a foot switch. An air flow valve mounted on the front panel controls both the speed of closing and the pressure of the electrode jaws.

The bench model unit is 10 in. wide x 16 3/16 in. long x 9 3/4 in. high, resting on rubber bumpers. The Eraser Co. Inc., 1068 South Clinton St., Syracuse, N.Y., 13201. [404]

Automatic machine impregnates armatures

An automatic trickle-impregnation machine can handle up to 540 armatures per hour. The armatures are continuously rotated in the machine for uniform heating, impregnating, jelling and curing. Resin is applied on both ends of the armatures simultaneously. Three-zone resistance heating gives precise control of the temperature throughout the process. Radiant heat or a combination of resistance and radiant heat are also available.

Because the resin is applied to the windings only, cleanup of the outside diameter, commutator and shaft is eliminated. There is no material waste or material recycle.

The compact in-line design of the model PT1-9-75 provides straight-through production line efficiency. The machine accommodates three armatures at a time with diameters of 2/5 in. to 2 3/8 in. and stack heights of 1/2 in. to 3 in. Possis Machine Corp., 825 Rhode Island Ave., South, Minneapolis, Minn., 55426. [405]

Specifically
Engineered
for RF
Components!



A-27 Superfine Q-max EXTREMELY LOW-LOSS RF LACQUER

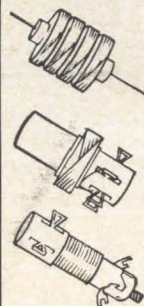

Q-MAX impregnating and coating composition penetrates deeply, seals out moisture, provides a surface finish. Q-MAX imparts rigidity and promotes stability of the electrical constants of high frequency circuits. Effect on the "Q" of RF windings is negligible.

Write for catalog today.

Q-max Corporation

MARLBORO, NEW JERSEY

Telephone: 462-3636 (Area Code 201)

Circle 255 on reader service card

High torque, Self-shielded

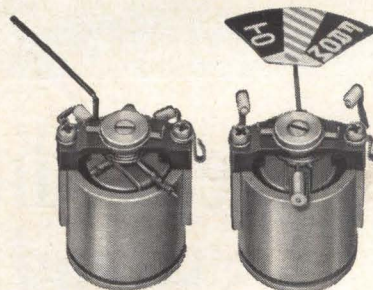

AL-2 (actual size)

moving coil mechanism

Versatile mechanisms for critical indicating and control systems have "On-off", "+, -", "Go-no go", null, left-right, or scale indicators. High torque, self-shielded core magnet design permits grouping of functions in small panel space. Moving coil weighs 100 mg less and provides at least 10% more torque than best previously available mechanism of this type. Wide choice of sensitivities; synchro or standard mounting.

AMMON

AMMON INSTRUMENTS, INC.
345 Kelley Street, Manchester, N. H. 03105

\$280.00

A REMARKABLE NEW IN-CIRCUIT SEMICONDUCTOR TESTER



measures leakage IN-CIRCUIT
of transistors, diodes, F.E.T.'s
...any semiconductor device

ALSO MEASURES ...

- Low and high power transistors for 1000 cycle Beta within range 1 to 1000.
- F.E.T. transconductance to 10,000 micromhos.
- Resistance across semiconductor electrodes.

FEATURES ...

- Battery operated.
- Rugged, drip-proof, high impact plastic case and cover.

OPTIONAL FEATURES and EQUIPMENT

- Automatic Beta calibration — sets collector current of transistor under test at 1 ma.
- One hand operated in-circuit test probe.

WRITE FOR TECHNICAL CATALOG

For Fast, Off-The-Shell Delivery, Call

DISTRIBUTORS

Electronic Wholesalers • Washington, D. C. • (202) 483-5200
 Allied Radio • Chicago, Ill. • (312) 421-6800
 Radio Electric Service Co. • Phila., Pa. • (215) 348-3010

STOCKING REPRESENTATIVES

Addelco Corp. • Needham, Mass. • (617) 444-4754
 Bonn Assoc. • Metuchen, N. J. • (201) 549-9573
 NBS, Inc. • Orlando, Fla. • (305) 432-4856
 Lightstone Corp. • Syracuse, N. Y. • (315) 454-3209



American Electronic Laboratories, Inc.
 P. O. BOX 552, LANSDALE, PA. 19446 • (215) 822-2929

Nowhere Else Can You Get All Of
These Features For Less Than \$875

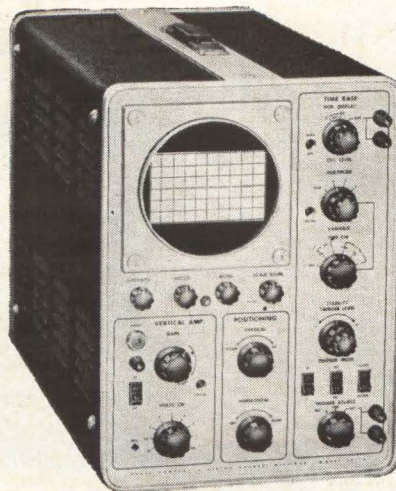

The New
Heath IO-14...
 a 5" DC to 8 MHz
 Scope with con-
 tinuous duty rat-
 ings, triggered
 sweep, 0.25 u sec
 coaxial vertical in-
 put and time base
 ... factory assem-
 bled & tested for
**\$399.00 . . . kit
 only \$299.00**

The Heath IO-14 Features The Engineering And Quality Components You Expect Only In Higher Priced Oscilloscopes. For example, switches are ball-detent type; all major control potentiometers are precision high-quality sealed components; all critical resistors are 1% precision; and vertical signal delay is provided through high-linearity coaxial delay lines. Here is the ultra-stable, low-noise performance demanded from a truly professional industrial, academic, electronic engineering laboratory oscilloscope. Check the prices and specifications yourself, and you'll agree the Heath IO-14 gives a new meaning to 'scope value.

- Kit IO-14 (with standard P-2 phosphor), 53 lbs. \$299.00
- Assembled IO-14 (P-2 phosphor), 47 lbs. \$399.00
- Assembled IO-14S (with long persistence P-7 phosphor for bio-medical or industrial use), 47 lbs. \$410.00
- Kit PK-1, Low-Capacitance Probe, 1 lb. \$4.95

IO-14 SPECIFICATIONS — (Vertical) Sensitivity: 0.05 v/cm AC or DC. **Frequency response:** DC to 5 MHz, —1 db or less; DC to 8 MHz, —3 db or less. **Rise time:** 40 nsec (0.04 microseconds) or less. **Input impedance:** 1 megohm shunted by 15 uuf. **Signal delay:** 0.25 microsecond. **Attenuator:** 9-position, compensated, calibrated in 1, 2, 5 sequence from 0.05 v/cm. **Accuracy:** ±3% on each step with continuously variable control (uncalibrated) between each step. **Maximum input voltage:** 600 volts peak-to-peak; 120 volts provides full 6 cm pattern in least sensitive position. **(Horizontal) Time base:** Triggered with 18 calibrated rates in 1, 2, 5 sequence from 0.5 sec/cm to 1 microsecond/cm with ±3% accuracy or continuously variable control position (uncalibrated). **Sweep magnifier:** X5, so that fastest sweep rate becomes 0.2 microsecond/cm with magnifier on. (Overall time base accuracy ±5% when magnifier is on.) **Triggering capability:** Internal, external, or line signals may be switch selected. Switch selection of + or — slope. Variable control on slope level. Either AC or DC coupling. "Auto" position. **Triggering requirements:** Internal; ½ cm to 6 cm display. **External:** 0.5 volts to 120 volts peak-to-peak. **Horizontal input:** 1.0 v/cm sensitivity (uncalibrated) continuous gain control. Bandwidth: DC to 200 kHz ±3 db. **General:** 5ADP81 or 5ADP2 Flat Face C.R.T. interchangeable with any 5AD or 5AB series tube for different phosphor characteristics. 4250 V. accelerating potential. 6 x 10 cm edge lighted graticule with 1 cm major divisions & 2 mm minor divisions. **Power supply:** All voltages electronically regulated over range of 105-125 VAC or 210-250 VAC 50/60 cycle input. (Z Axis) Input provided. DC coupled CRT unblanking for complete retrace suppression. **Power requirements:** 285 watts. 115 or 230 VAC 50-60 Hz. **Cabinet dimensions:** 15" H x 10½" W x 22" D includes clearance for handle and knobs. **Net weight:** 40 lbs.



FREE
 1967
 Heathkit
 Catalog
 Use this
 coupon
 for your
 free copy.

Heath Company, Dept. 520-28
 Benton Harbor, Michigan 49022

Please send FREE Heathkit Catalog & Information describing the New Heathkit IO-14 Oscilloscope

Enclosed is \$ _____, plus shipping.
 Please send model _____

Name _____

Address _____

City _____ State _____ Zip _____

Prices & specifications subject to change without notice.

TE-155

lowest cost in the industry!

MEDIUM & HIGH POWER
SP SERIES SILICON

Deltron LAB SUPPLIES



36 MODELS . . . TO 100 VOLTS
TO 50 AMPS . . . 1200 WATTS

how is it done?

Deltron has substituted design sophistication for brute force methods . . . has cut number of components . . . resulting in lowest cost on the market today for lab supplies of this quality. Features include:

- Automatic cross-over — gives both voltage and current regulation.
- 0.01% regulation.
- 500 microvolts ripple.
- 71°C convection cooled.

Request technical bulletin for all the facts.

See our complete catalog
in eem . . . Section 4000

D 102

Deltron

WISSAHICKON AVE., NORTH WALES, PA. 19454
PHONE: (215) 699-9261 TWX: (510) 661-8061

New Materials

Thermally conductive bonding adhesive



An adhesive with high-thermal conductivity has been developed for bonding together heat sinks and conductive metals. Thermal bond 312 is supplied in two-part, ready-to-mix-and-use tubes containing bonding compound and hardener.

The material has a thermal conductivity of 7.4 BTU per hr-ft² per ° F per inch and a dielectric strength of 650 volts per mil. The coefficient of thermal expansion is matched to that of aluminum since the compound is designed primarily for use with aluminum heat sinks. The cured compound exhibits excellent bond-shear strength.

The adhesive is normally supplied in cartons of 12 boxes. Each box contains two 5-oz. tubes of the bond and hardener for \$46.60. Quotations will be supplied for bulk volumes on request. Astrodyne Inc., 207 Cambridge St., Burlington, Mass., 01803. [406]

Encapsulant resists high temperature

A two-part potting and encapsulating epoxy system, Stycast 2762, is designed for use at high temperatures. Its thermal conductivity, the manufacturer reports, is well above that of most epoxy systems, yet it maintains its electrical insulating qualities.

Stycast 2762 with Catalyst 14 or Catalyst 17 gives a resin mix with

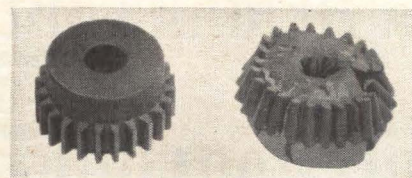

a pot life of about 24 hours. It is cured at high temperature, and is used at temperatures in the 400° to 600°F range; curing should be done in steps. Stycast 2762 with Catalyst 14 withstands a 700°F environment for a few hours and a 600°F environment for much longer periods. One test at 570°F showed a weight loss of only 0.3% in 3 days.

The figure at left in the photo shows Stycast 2762 after 50 hours at 500°F; at the right, conventional epoxy after 20 hours at 500°F.

The encapsulant is also radiation resistant. After exposure to 6 x 10⁹ roentgens from a cobalt-60 source, there was no evidence of damage.

Stycast 2762 is available in 15-lb and 2-lb containers for about \$2.50 per pound.

Emerson & Cuming, Inc., Canton, Mass., 02021 [407]

Heat-shrinkable tubing for component use

A high temperature tubing called Insultite TFE is flexible and heat-shrinkable. It is expected to find wide use in the aerospace and electronics industries.

The new polytetrafluorethylene tubing is available in standard 1.7 to 1 shrink ratio or with a shrink ratio of 4 to 1. Designed for a maximum continuous operating temperature of 200°C, Insultite TFE will shrink to a predetermined diameter upon application of heat in excess of 621°F.

Specific applications for TFE cited by the company include capacitors, relays, semiconductors and cable jacketing.

The material comes in standard lengths of four feet, in standard milk-white translucent color and is available in 30 days.

Electronized Chemicals Corp., Box 57, Burlington, Mass. [408]

**CHECK
TENSION
QUICKLY**

WITH THE
**GENALEX
TENSION
GAUGE**

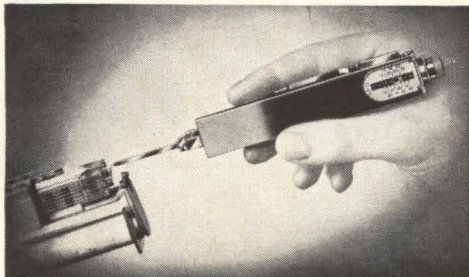

FOR checking the tension of springs or similar resistive forces.

- Most precise
- Easiest to read

Available in six tension ranges from 4 to 2500 grams

for free illustrated leaflet, write to



11 UNIVERSITY ROAD, CAMBRIDGE 38, MASS.
U. S. AGENTS FOR THE GENERAL ELECTRIC COMPANY, LTD. OF ENGLAND
Circle 259 on reader service card

New! ALL SILICON
DC REGULATED
POWER SUPPLY

LABORATORY, MODULAR OR RACK
CONSTANT VOLTAGE CONSTANT CURRENT
WITH AUTOMATIC CROSSOVER



OUTPUT—0-20 DC Volts, 0-2 DC Amperes

INPUT—105-125 Volts, 50-60 Hzs, 85 Watts

METER RANGES—0-20 Volts, 0-2 Amps., 0-500ma., 0-200ma., 0-50ma. DC

Accuracy plus or minus 2% of full scale on all ranges.

REGULATION—

VOLTAGE .005% plus 1 mv. for load changes from no load to full load.

.01% plus 1 mv. for line voltage changes from 105 to 125 volts.

CURRENT .03% plus 0.2ma. for load changes from 0 to 20 volts DC.

.01% plus 0.2ma. for line changes from 105 to 125 volts.

RIPPLE AND NOISE are less than 100 microvolts RMS at constant voltage.

0.4ma. RMS at constant current.

VOLTAGE RECOVERY TIME—less than 50 microseconds with any changes in load.

NO VOLTAGE OR CURRENT OVERSHOOT at turn on, turn off, or AC power removal under any condition.

REMOTE SENSING, REMOTE RESISTANCE AND VOLTAGE PROGRAMMING available from terminals at rear of the unit.

OVERVOLTAGE PROTECTION UNIT applies an instant short circuit across the load when voltage exceeds any set amount from 4 to 20 volts.

WRITE FOR COMPLETE CATALOGUE ON D.C. POWER SUPPLY UNITS

FRONT AND REAR OUTPUT TERMINALS. Rated performance is maintained at either set terminals with sensing links in place on back panel.

TEN TURN VOLTAGE AND CURRENT output controls available. See table of model numbers.

SMALL SIZE—4-3/16" x 5-3/8" x 9-1/2"

TEMPERATURE COEFFICIENT does not exceed .01% per degree centigrade.

TEMPERATURE STABILITY Long term stability better than .05% plus 5mv. for 12 hour period after warm up.

MAXIMUM ALLOWABLE AMBIENT TEMPERATURE with full out put is 60° C

POWERS SUPPLY MODEL NO. 20021 Standard unit with one turn current and one turn voltage output controls \$110.00

POWER SUPPLY MODEL NO. 20022 Same unit except one turn current and ten turn voltage output controls \$125.00

POWER SUPPLY MODEL NO. 20023 Same unit except ten turn current and ten turn voltage output controls \$135.00

Hitching Post for High-Spirited Electrons...



JOHNSON'S NEW
MINIATURE "6-WAY"
111-200 BINDING POST

- * Compact Pre-Assembled Design
- * Short Front Panel Projection
- * 5,000 VDC Breakdown

Hold your horses! Look first at Johnson for binding posts . . . for instance, at the #111-200 series designed for compact test equipment applications. Tough, low-loss polyamide body fully insulates stud, provides higher voltage breakdown. Front projection 25/32" max. with thumb nut open . . . only 21/32" closed. Thumb nut is self-captivated . . . cannot work loose. Equipped with single 1/4"-32 nut for fast mounting — no time consuming spacers or mounting hardware required. 6-Way feature permits connection by tip plug, alligator clip to stud, wire wrapped around stud and clamped, wire (max. size #12) through center hole, clamped, and clamped spade lug.

ELECTRICAL CHARACTERISTICS:

Current rating 15 amps. thumb nut to terminal; five amps. tip jack to terminal.

Capacitance to 1/8" panel 3 pf.

Insulation resistance greater than 200 megohms after MIL-T-5422B humidity test.

Also available in Series 111-100 (15 amps, 8,000 VDC Breakdown) and Series 111-300 (40 amps, 7,000 VDC Breakdown).

WRITE NOW FOR FREE SAMPLE AND COMPLETE INFORMATION ON JOHNSON CONNECTOR LINE



Tel. 609-646-0197

FIRE ROAD RT 2 BOX 64 E. PLEASANTVILLE, N.J. 08232



E. F. JOHNSON COMPANY
3056 Tenth Ave. S.W. • Waseca, Minnesota 56093

INTRODUCING

A New Member of
The
Transformer Electronics Co.
Family of
Miniature Regulated

POWER SUPPLIES

THE 6 WATT
9589 SERIES
(23 Models)

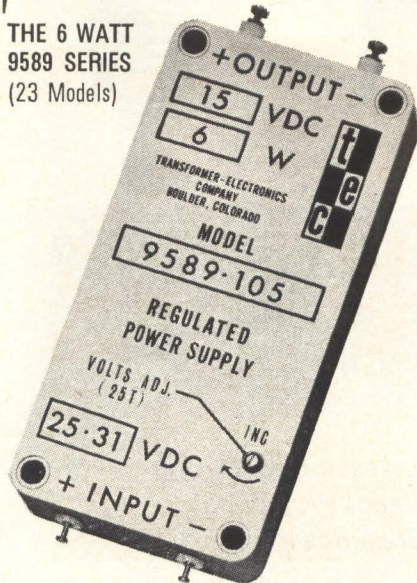

Output Power Capability:	6 watts
Operating Temperature:	-55°C to +100°C
Input Voltage:	25-31vdc
Line Regulation:	0.1%
Load Regulation:	<3% (½ to full load)
Output Ripple:	<0.6% p-p
Efficiency:	>46%
No Load Current:	<75 ma
Voltage Adjustability:	±10%
Volume:	4.3 cu. in. (1.75"x 3.5"x .7")
Weight:	7 oz.
Voltage Range:	5 to 5000vdc; ±15, ±25, ±50, ±100

Other T. E. C. Power Supplies—**1 WATT**, 9583 Series; **3 WATT**, 9567 Series; **10 WATT**, 9584 Series—Write or Call for complete details.



**TRANSFORMER
ELECTRONICS
COMPANY**

BOULDER INDUSTRIAL PARK
BOULDER, COLORADO
TWX 303 443-2561 PHONE (303) 442-3837

POWER SUPPLIES • INVERTERS
CONVERTERS • TRANSFORMERS

New Books

Fundamentals of higher math

Topics in Advanced Mathematics
for Electronics Technology
Stephen Paull
John Wiley & Sons, Inc., 420 pp., \$4.95

Here, in one paperbound volume, is much of the advanced mathematics—including infinite series, the contributions of Fourier and Laplace, vector analysis and matrix algebra—that is widely applied in electronics engineering. Intended primarily as an introduction for electronics technicians or veteran engineers who haven't formally studied all of these subjects, the book can also serve as a refresher for engineers who have been exposed to the techniques before.

The approach is not rigorous; essential definitions and theorems are stated and applied, but not proved. The presentation is in clear and simple terms and includes many illustrative examples, most of which are classic electronic problems.

Each of the eight chapters covers a separate topic or two, so that each can be studied separately. Problems, some with answers, follow each major section, and an excellent topical bibliography is provided for readers wishing to delve deeper.

Paull begins with infinite series. He covers definitions, tests for convergence and representation of functions of power series. The treatment is clear, but perhaps too brief.

In the two-chapter discussion of the Fourier series both trigonometric and complex forms are covered. The Fourier integral is developed as a limiting case of the series, with emphasis on both forms. Transforms of several common waveshapes and their singularity functions are worked out.

The author gives lucid introductory definitions of ordinary differential equations, most of them linear, followed by a thorough discussion on applying the equations to linear, time-invariant circuits.

In a succeeding chapter, the Laplace transform is applied to the solution of linear, ordinary differential equations for several circuits. Theorems, properties, the inversion

integral and the use of transform tables are covered.

Gamma, beta and Bessel functions are combined in one chapter, along with the various derivations of the Bessel solution. These are followed by vector analysis. While there is a balanced assortment of the integration of vector functions would have been helpful. A well-written chapter on determinants and matrix algebra concludes the book.

Robert Goldberg
Radio Receptor division
General Instrument Corp.
Hicksville, N.Y.

Designer's time-saver

American Microelectronics Data
1966-67 Edited by G.W.A. Dummer and
J. MacKenzie Robertson
Pergamon Press, 1,515 pp., \$40

Any engineer whose secretary spends more than three or four working days during a year in writing to semiconductor manufacturers for integrated-circuit data sheets, then filing the returns, might find this eight-pound compendium of data sheets just the thing to save time, effort and money.

It is, of course, incomplete, as any attempt to gather manufacturers' literature inevitably is. Nevertheless, one blanches at the exclusion of manufacturers such as the Transatron Electronic Corp., the Norden division of United Aircraft Corp., Radiation Inc. and the Union Carbide Corp. Another omission is that of the semiconductor division of the International Telephone and Telegraph Corp. This exclusion is particularly curious since data sheets from IRT's Cannon Electric and Federal Laboratories are included.

One might conclude either that the omitted companies issued no data sheets during the time the book was being compiled (the sheets are not dated, so when they were collected is unclear) or that the publishers merely failed to obtain them.

Despite its shortcomings, the book is probably as up to date as the personal files of most engineers.

500,000 Bits/Second PCM SYSTEMS

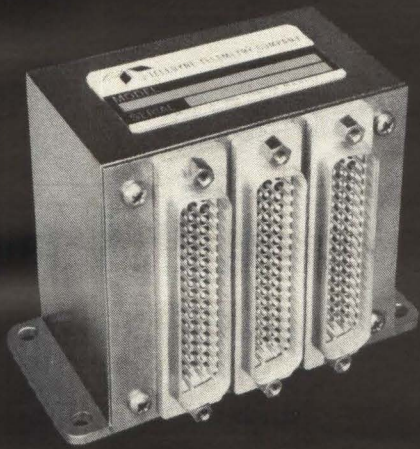

710 PCM SYSTEMS require as little as 26 cubic inches and weigh as little as 30 ounces. Space and weight are saved in Type 710 Microcircuit PCM Systems because they use MEMA.*

Provides up to 256 channels of high, low and/or digital inputs.

FET analog input gates.

Offset and scatter below ± 25 microvolts.

Backcurrent below ± 0.1 microampere.

NRZ 10-bit word output.

Sample rates from 1 to 50,000 words.

*Micro Electronic Modular Assemblies, a high density integrated circuit packaging concept developed by TELEDYNE, INC.

For complete information on Teledyne Telemetry components and systems contact:



**TELEDYNE TELEMTRY
A TELEDYNE COMPANY**

12964 Panama Street
Los Angeles, California 90066
Phone (213) 870-9831
TWX: 910 343 6855

Are you up to date... on dielectric tubing materials?



Send for your FREE copies

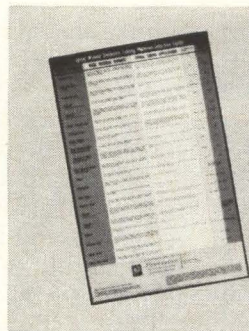

Tubing Materials Chart

This chart gives a complete listing of spiral-wound dielectric tubing uses and material features. A handy reference which, at a quick glance, points out facts you may overlook in tubing selection.



Dielectric Tubing Catalog

This 8 page catalog gives basic information on Precision's spiral-wound dielectric tubes. Illustrates end-product uses, covers, in detail, the advantages of each type of dielectric tube.



Precision
Paper Tube Company

1033 S. NOEL AVE., WHEELING, ILL. 60090

Phones: Chicago, 631-1445, Long Distance, 312-537-4250

Please rush my copies of the
tubing materials chart and tubing catalog

NAME _____
COMPANY _____
ADDRESS _____
CITY _____ STATE _____ ZIP _____

Radar Equipment Design Engineers

The Hughes Radar & Space Electronics Laboratories have important opportunities available for experienced Engineers.

Product design

Engineering assignments exist which involve the design and conceptual development of transmitters, modulators and power supplies employing BWO, CFA, Magnatron, Klystron and Traveling Wave Tubes. Desirable background would include a working knowledge of fabrication techniques, stress and thermal analysis, cooling, encapsulation, microminiaturization or high-voltage design.

Openings are available on nearly all levels—from those with a minimum of two years of applicable, professional experience through those who are interested in and qualified for senior supervisory positions.

Accredited degree and U.S. citizenship required.

For immediate consideration, please airmail your resume to:

MR. ROBERT A. MARTIN
Head of Employment
Hughes Aerospace Divisions
11940 W. Jefferson Blvd.
Culver City 45, California



An equal opportunity employer — M & F

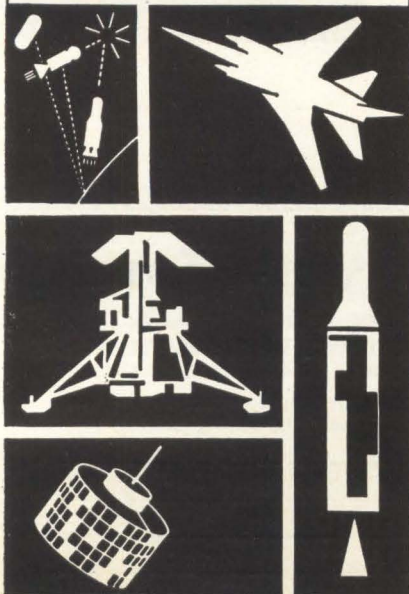

Technical Abstracts

50-kw solar panels

Solar cell power systems for electric propulsion
A. Krausz, W. Luff and P. Bauer
TRW Systems, Redondo Beach, Calif.

Aside from the millions being spent on solar cells, more than \$2 million a year is devoted to figuring out how to build huge, but lightweight, solar panels. The panels would have to supply at least 50 kilowatts of power to the ion engines of interplanetary spacecraft.

Some designers are working on arrays of standard silicon solar cells, others on silicon dendritic webs that can roll up like tape and still others on large area, thin-film solar cells based on plastic or other flexible materials. Over-all weights will range from 25 to 65 pounds per kilowatt.

The lightest of the experimental thin-film cells is cadmium sulfide on plastic film. With anticipated improvements in efficiency, their weight should be about 10 pounds per kilowatt in a few years and 6 pounds per kilowatt by 1970.

Cost of the CdS cells is about \$100 per watt, about that of silicon cells. By next year the cost for CdS should drop to \$30 to \$50 a watt and then to around \$5 when mass production begins. The problems of cadmium sulfide degradation have been solved, with the exception of thermal cycling problems.

However, many mechanical problems are not yet solved, such as the best way of pointing the big panels at the sun, how to balance the structure and how much of a threat meteorite damage represents.

Today's ion engines don't place a heavy drain on power supplies. Every once in a while, they draw several hundred watts, as they electrically propel satellites into orbital positions. But if ion engines are to be used for primary propulsion, clusters of engines and kilowatts of high voltage power will be needed, along with multiple power conditioning and control circuits.

Ideally, the solar panel would supply high voltage directly to the engine, without an intervening d-c to d-c converter. However, this would still not eliminate the need for voltage regulation, since the

panel output will vary as the distance between the spacecraft and the sun changes.

Generally, a switching-type converter is used. To keep the weight of the power conditioning equipment below 12 pounds per kilowatt or less—the desired figure—the converter's switching frequency should be high and losses low. Special circuits can minimize switching losses, such as series-parallel combinations of medium-/power converter modules.

Presented at the AIAA Third Annual Meeting, Boston, Nov. 29-Dec. 2.

Post checks

The effect of post geometry on solderless, wrapped termination performance
Mark Auriana
Burdny Corp, Norwalk, Conn.

How does the shape of a wrapped-wiring terminal post affect the reliability of the connection?

To answer this question, two of the most common wrap post geometries—0.045-inch square and 0.031 x 0.062-inch rectangular, both of which are specified in MIL-STD-1130 for solderless, wrapped electrical connections—were wrapped with wire. A machine then measured how much force was required to strip the wire from the post.

Test samples were prepared with the minimum acceptable number of wraps specified in MIL-STD-1130: 3¾ turns for 20-gauge wire, 4¾ turns for 22 and 24-gauge wire. The amount of force required to strip the wires from the square posts differed little from the force to strip the rectangular posts. However, 24-gauge wire wrapped on the square posts could be stripped with less than the minimum MIL-STD-1130 force of seven pounds. It took a little more than seven pounds to strip the same wire wrapped on rectangular posts.

If the wiring is subjected to mechanical stress, a rectangular post will probably permit more reliable wiring joints.

Presented at the 15th Annual Wire and Cable Symposium, Atlantic City, N.J., Dec. 7-9, 1966.

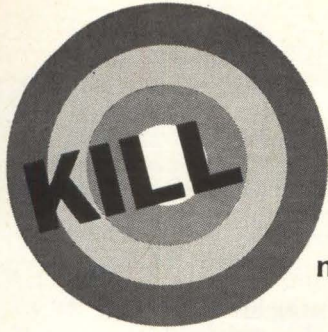

**microbial
contamination
product spoilage,
downtime,
need for excessive
additives**

for use in DEIONIZED WATER SYSTEMS

Steroline's Aquafine Ultraviolet purification systems are designed to produce unlimited quantities of 99+% of safe, pure water and other liquids.

Skilled Steroline specialists will design the most economical purification system for you...reducing bacterial build-up...eliminating downtime...ending product spoilage...reducing maintenance costs. And, Steroline purification systems are available with special warning device and/or automatic shut off. Whether you select a portable or permanent system, you'll find that your over-all savings quickly exceed your capital investment.

Get the facts on liquid purification. Write:

Steroline Systems Corporation

11809 (J) East Slauson Avenue
Santa Fe Springs, California 90670
Telephone: (213) 698-8157 Cable: Sterline

DISTRIBUTORS! Valuable territories open. Write for full information.
Circle 221 on reader service card

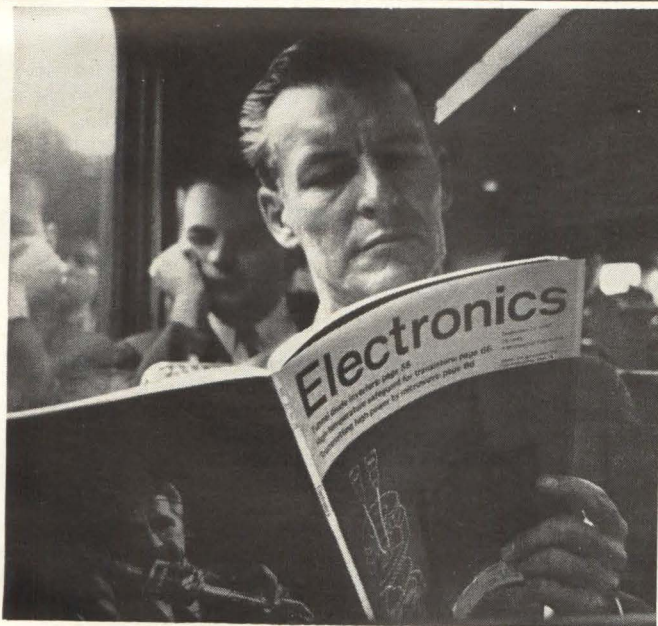

**Great editorial is
something he takes to work**
(What a climate for selling!)

Electronics

A McGraw-Hill Market-Directed Publication
220 West 42nd Street, New York, N.Y. 10036

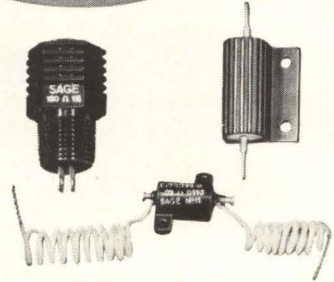
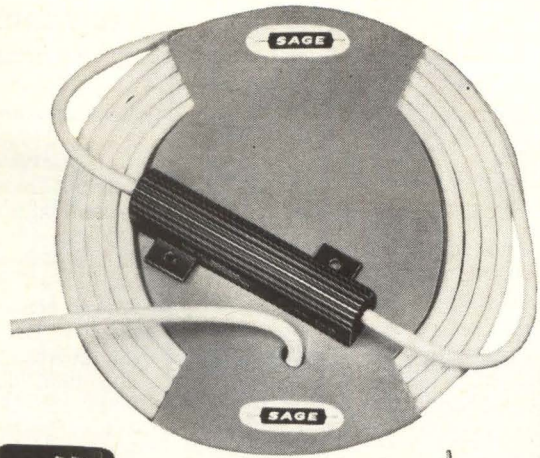

EVER SEE THIS COLLECTION OF POWER RESISTORS BEFORE?

Don't feel left out because no one else has either. Each resistor or network illustrated is designed for custom fit and performance in some customer's special application.

If provided a few details of your extraordinary resistor needs perhaps SAGE can help you out too. Write or call industry's leading producer of miniature precision wire-wound resistors.



SEE OUR SPECIFICATIONS IN
VSMF
THE MICROFILM CATALOG FILE

SAGE

SAGE ELECTRONICS CORP.
BOX 3926 • ROCHESTER, N. Y. 14610

PHONE: 716-586-8010

Ultrasensitive relays



The circuit drawing below indicates just one of many complex control problems solved with Barber-Colman Micropositioner® polarized d-c relays.

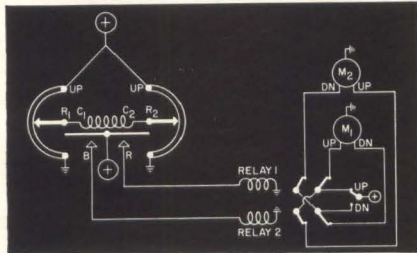

SYNCHRONIZING CONTROL

Here is a simple way to equalize rate of change on separately powered actions such as aircraft landing flaps, flow of fluids into a mixing tank, and synchronizing rotary output by means of tach generators instead of resistance elements.

Motor No. 1 turning faster than No. 2 will move potentiometer R1 toward (+) at a faster rate than R2. This causes current flow through the Micropositioner coil from C1 to C2, closing contact R and energizing relay No. 1 which opens the circuit to motor No. 1.

Micropositioner will hold this position until motor No. 2 (still moving) advances its potentiometer, reducing current to restore balance in Micropositioner. This de-energizes relay No. 1, and reapplies current to motor No. 1.

Increasing speed of motor No. 2 would actuate the circuit in reverse. If multiple-speed devices are controlled, action of the relays can be used to speed up the slow unit instead of stopping the fast one.

If you need reliable synchronous control, test a Micropositioner in your circuits. Write for more ideas in our technical bulletins.

BARBER-COLMAN MICROPOSITIONER®

POLARIZED D-C RELAYS

Operate on input power as low as 40 microwatts. Available in null-seeking and magnetic-latching "memory" types of adjustment. Also transistorized types with built-in preamplifier. Write for our latest catalog with full information on polarized relays.

BARBER-COLMAN COMPANY
Electro-Mechanical Products Division
Dept. M, 12129 Rock Street, Rockford, Illinois

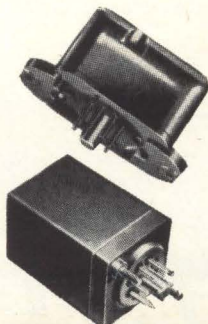

New Literature

Desktop computers. Mathatronics, a division of Barry Wright Corp., 241 Crescent St., Waltham, Mass., 02154, has a fold-out brochure outlining the complete Mathatron line of desktop computers.

Circle 420 on reader service card.

Power conversion equipment. Wanlass Electric Co., 2175 South Grand Ave., Santa Ana, Calif., 92705, offers a catalog that includes details on 10 new lines and 199 models of voltage regulators, power supply units and a dynamic line filter that removes scr spikes. [421]

Data modem. Milgo Electronic Corp., 7620 N.W. 36th Ave., Miami, Fla., 33145, has available a two-page bulletin on the data modem 4400, a unit developed to transmit 2,400 bits per second on unconditioned voice-grade, schedule 4 telephone lines. [422]

Tone receiver. Quindar Electronics Inc., 60 Fadem Road, Springfield, N.J., 07081, has prepared a two-page bulletin describing in detail a transistorized, frequency shift tone receiver. [423]

Control grips. Guardian Electric Manufacturing Co., 1550 West Carroll Ave., Chicago, Ill., 60607. Bulletin J1 covers a broad line of grip types including servocontrol, cyclic control, antenna control, Gemini control and special control. [424]

Casting resins. The Baker Castor Oil Co., Bayonne, N.J. A report on new and conventional resins used in the molding, casting and spray coating of electronic components and assemblies includes performance and cost evaluation. [425]

Small computers. Digital Equipment Corp., 146 Main St., Maynard, Mass., 01754, has published a 544-page handbook detailing its small computer product line and designed to be a source book of basic computer technology for scientists, engineers and students. [426]

Precision alloy wire. Fort Wayne Metals Inc., 3211 MacArthur Drive, Fort Wayne, Ind. A four-page brochure entitled "Clean Metals" describes the problems caused by tiny foreign matter inclusions and voids in stainless alloy wire, especially in small sizes below 0.005 in. in diameter. [427]

Solid state relay. Solid State Electronics Corp., 15321 Rayen St., Sepulveda, Calif., 91343, has available a bulletin describing the model SSR-1285-5050, a silicon transistorized, static switching relay. [428]

Displaying computer output. Image Instruments Inc., 223 Crescent St.,

Waltham, Mass., 02154. A six-page applications note that describes the coupling of the Electrostore scan converter to the computer and visual display, covers the advantages of this system for remote displays and multiple-access computers. [429]

Stripline bandpass filters. Elpac Microwave, a division of Elpac Inc., 3800 Campus Drive, Newport Beach, Calif., 92660, has issued a data sheet describing the unusual design characteristics of its microwave stripline bandpass filters. [430]

Circuit protectors. Airpax Electronics Inc., Cambridge, Md., 21613. Bulletin 16E-5R shows how interlocking circuit protection is made easy with the series 50 APL circuit protectors. [431]

Coaxial cable. Phelps Dodge Electronic Products Corp., 60 Dodge Ave., North Haven, Conn., 06473. A 12-page technical bulletin outlines electrical, physical and mechanical characteristics of Styroflex coaxial cable, plus performance curves and tables. [432]

Operational amplifiers. Analog Devices Inc., 221 Fifth St., Cambridge, Mass., 02142. Part 5 in a continuing series of application notes is a 12-page handbook covering theory and applications of chopper-stabilized operational amplifiers. [433]

Computer development techniques. Scientific Data Systems, 1649 17th St., Santa Monica, Calif., 90404, has prepared a 16-page brochure describing the design, development and production of its new line of Sigma computers. [434]

Precision reference diodes. Motorola Semiconductor Products Inc., Box 955, Phoenix, Ariz., 85001, has published a brochure to familiarize the circuit designer with the fabrication, function, testing and specification of a line of precision reference diodes. [435]

Magnetic core memories. Di/An Controls Inc., 944 Dorchester Ave., Boston, Mass., 02125. Catalog 3-700 describes magnetic core memory systems for military, aerospace and commercial applications. [436]

Transistor chopper. Airpax Electronics Inc. Cambridge, Md., 21613. Type ST-5 transistor choppers, suited for operational amplifiers and servoinstruments, are described in bulletin C-124. Typical application circuits are included. [437]

Synchros and resolvers. Vernitron Corp., 59 Central Ave., Farmingdale, N.Y., has published a six-page brochure in color on its line of multispeed synchros and resolvers for high-accuracy data transmission. [438]

there are two sides to DigiTec:
low cost • high performance

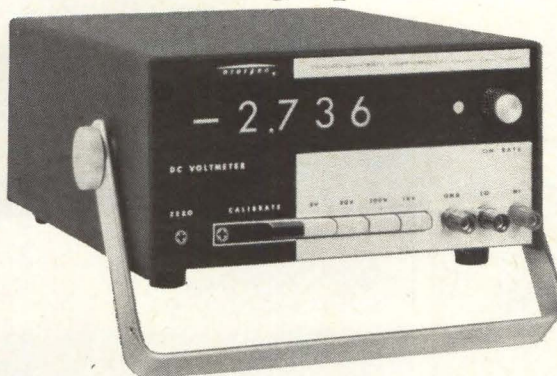

Model 252
from \$585

ALL SOLID STATE digital instrumentation
the series 250 digital voltmeter

featuring

- High Accuracy 0.05% of Reading
- BCD Output
- Data Acquisition to 20 Readings/Sec.
- "Plug-in" Versatility
- Ultra Long Life Nixie Readout—4 digits
- Automatic Polarity Selection and Indication
- Constant 10 megohms Input Impedance
- No Blinking Readout
- Buffer Storage
- AC Rejection 75 DB @ 60 Hz
- 50% Calibrated Over-range
- Compatible with existing DigiTec instruments
- Maximum Reading—15000 digits

DIGITEC by **UNITED SYSTEMS CORPORATION**

918 Woodley Rd., Dayton, Ohio 45403

For Complete Specifications request new catalog D-67

Stocking Representatives Throughout the World

Circle 261 on reader service card

from BENRUS
TRIPLEX X-Y RECORDER

- 3 independent, solid state RA840C Indicators, in 1/2 the rack panel space of 1 conventional scope!
- Completely assembled to 3 1/2" x 19" rack panel.
- Requires only 10 1/2" behind panel.
- Each section has its own power supply.
- Conforms with MIL environmental specifications.

MODEL RA840C-3

3 1/2" High
COMPLETE
\$870

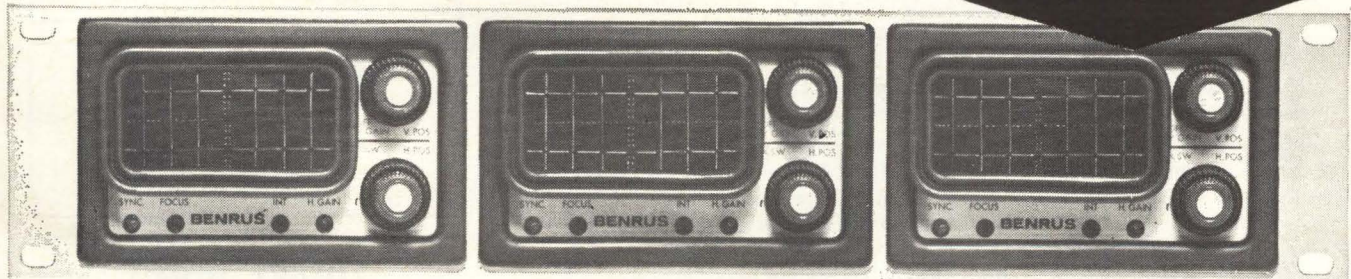

FEATURES (of each section):

- Identical X-Y amplifiers;
- Sensitivity 1 v/cm, variable to 10 v/cm;
- Frequency response DC to 200 KHz (3 db);
- DC coupled blanking provided.

Individual Model RA840C Indicators — \$285 each.

Model RA840A scopes, with preamps and sweeps, are also available in the triplex configuration.

Ask your Benrus Technical Products representative for a demonstration, or write us for detailed specifications.

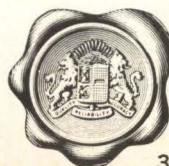

BENRUS

TECHNICAL PRODUCTS DIVISION

30 CHERRY AVENUE • WATERBURY, CONNECTICUT 06720

Karman Vortex Street



How do the vortices cause sound emitting vibrations?

NRL invites you to help find the answer.

This is just one of the problems currently being studied at the Naval Research Laboratory. There are hundreds of others equally intriguing.

NRL, the Navy's corporate laboratory, is engaged in research and development embracing practically all branches of physical and engineering science and covering the entire range from basic investigations of fundamental problems to applied and developmental research.

The Laboratory has current vacancies and a continuing need for electronic and mechanical engineers, physicists, chemists, metallurgists, mathematicians, oceanographers, and technical writers and editors for challenging assignments.

Persons appointed receive the full benefits of career Civil Service including regular salary increases and liberal retirement. The Metropolitan Area offers excellent living conditions and recreational facilities to suit a variety of needs. Six local universities provide opportunities for graduate study in almost any field.

The Laboratory encourages its employees to further their professional education. Send resume or Standard Form 57 to:



The Director (Code 1818-3)
Naval Research Laboratory
Washington, D.C. 20390
An Equal Opportunity Employer

CLASSIFIED ADVERTISING
SEARCHLIGHT SECTION
 BUSINESS OPPORTUNITIES
 USED OR SURPLUS EQUIPMENT

New **VACUUM PENCIL**
 for picking up miniature parts
 \$7.50 ea.
 Selected Distributorships available.
PHILIP FISHER COMPANY
 7 CAMERON ST., WELLESLEY, MASSACHUSETTS

CIRCLE 966 ON READER SERVICE CARD

YOUR IDEAS may be worth a Million Dollars, but if they stay in your head they're not worth a nickel! Now through membership in the International Idea Club, Inc. you can sell your ideas and get maximum cash rewards. Legally protected, your ideas are consistently exposed to interested parties. Send only \$1.00 today for big illustrated book "Millions For Your Ideas", showing how you can profit by membership in one of the nation's most dynamic organizations. International Idea Club, Inc., Dept. E, 135 Columbus Ave., Boston, Mass. 02116

CIRCLE 967 ON READER SERVICE CARD

RADAR AUTO-TRACK & TELEMETRY ANTENNA PEDESTALS
 3 & 10 CM. SCR 584 AUTOTRACK RADARS. M-33 RADAR
 TPS-1D SEARCH. APS-45 TPS-100 HT. FINDERS. WX RADARS.
 FPN-32GCA. APS-10 APS-17B APS-77 (AMTI) SEARCH
 APN-102 DOPPLER. DOZENS MORE CARINORONS P.F.S.
 25-5-1-2-3-6 MEGAWATT PULSE MODULATORS. CAVITIES.
 PULSE TRANSFORMER. IF STRIPS. WAVEGUIDE. BENDS
 200 MC. 1 KMC. 3 KM. 6 KMC. 9 KMC. 24 KMC. RF PKGS.
RADIO RESEARCH INSTRUMENT CO.
 550 5TH AVE., NEW YORK 17, N.Y. JU 6-4191

CIRCLE 968 ON READER SERVICE CARD

2? 3? 4? 5? 6?
FORGET 'EM ALL!
 When you do business with Number One, you can afford to forget Number 2, 3, 4, 5, and 6! We want to buy electronics and test equipment—both military and commercial.
 If you have a single piece or a trainload—we'll pay you the top dollar bar none! We airmail your check the same day your goods arrive and we pay the freight! Save time, money, headaches and aggravation! Tell us what you have—what you want! And P.S.: Do it today!
COLUMBIA ELECTRONICS, Dept. EL.
 4365 West Pico Blvd., Los Angeles, Calif. 90019
 Phone: (213) 938-3731

CIRCLE 969 ON READER SERVICE CARD

PROFESSIONAL SERVICES

Donald C. Harder, Inc.
 Magnetic Component Engineers
 Reactors—Transformers—Filters
 Serving the Research Laboratory
 2580 K Street, San Diego, Calif. 92102
 Phone (714) 239-8021

YOU'RE HIRED!
 Do you need electronics engineers or technical management men? Electronics magazine is the way to recruit them. Electronics is designed specifically for the working engineer. 68,000 subscribers and an additional 133,000 pass-along readers turn to it to keep up with their industry. You can find the man that meets your qualifications with an advertisement in the Employment Opportunities Section.

For rates & information write: Electronics, a McGraw-Hill Publication, Classified Advertising Division, Post Office Box 12, New York 10036.

Some organizations won't support an R&D program unless there's an immediate payoff.

We're different.

Engineers and scientists at our eight laboratories work in basic and applied research on projects that are evaluated not by the ring of the cash register, but by their ultimate value to the security of the nation.

Some of these projects are completed in months. Others go on for years. But, because these projects are of national significance, the men who work on them are backed by the full resources of Navy and the Federal government and provided

with the facilities and equipment they need to do the job.

If you're tired of starting projects and then being forced to drop them just when you are beginning to make some progress, we invite you to consider a career with us. To explore the possibilities, get in touch with the Employment Officer (Dept. C) of the particular laboratory which interests you. He'll bring you up to date on the benefits of career Civil Service and the unique recreational and educational opportunities you and your family will find in the Washington, D.C. area.

Naval Laboratories of the Washington, D.C. Area*

1. Naval Research Laboratory Washington, D. C. 20390

—places heavy emphasis on pure and basic research in the physical sciences to increase the store of knowledge of the sciences, as well as on applied problem-solving research under the sponsorship of various government activities to improve materials, techniques and systems.

2. Naval Ordnance Laboratory White Oak, Maryland 20910

In addition to being one of the nation's leading establishments for research and development in undersea warfare, NOL is the Navy's principal aeroballistic activity and a leader in the development of air and surface weapons, with a broad research program including explosives, electrochemistry, polymers, magnetism, acoustics, materials, solid state and nuclear phenomena.

3. Naval Oceanographic Office Washington, D. C. 20390

—engaged in long range technical and scientific research in general oceanography, geophysical and geodetic surveys, bathymetry, oceanographic instrumentation, information processing, cartography and other important areas.

4. David Taylor Model Basin Washington, D. C. 20007

—fundamental and applied research leading to the development of advanced ship design concepts and related to the resistance, stability, and propulsion of ships and aircraft; the strength of ship structures and

the survivability of ships under attack; hydro-structural acoustics and mechanical vibration, as applied particularly to silent operation of ships; the application of mathematics and high-speed computer techniques to engineering and logistics problems of the Navy; and development of new ship types such as surface-effects ships and hydrofoils.

5. Naval Weapons Laboratory Dahlgren, Virginia 22448

—engaged, first, in studying and analyzing advanced weapons systems, ballistics, and astronautics through basic and applied research in mathematics, physics, and engineering . . . and, second, in achieving maximum degree of competence in various sophisticated DOD projects utilizing the most advanced computer technology and systems available.

6. Marine Engineering Laboratory Annapolis, Maryland 21402

—R&D in naval shipboard and submarine machinery and auxiliary systems (electrical, propulsion, control, etc.). Emphasis on ship silencing, new concepts in energy conversion and control, ways to minimize friction and wear, special operating machinery for deep diving vessels; naval alloys to meet all ocean environmental conditions; minimization of ships' magnetic signatures; and systems engineering.

7. Naval Propellant Plant Indian Head, Maryland 20640

—develops and maintains the Navy's technical competence in missile, gun and rocket propellants. Conducts R&D in chemistry, propellants, propellant ingredients, propellant processing; performs product and production engineering, chemical engineering, chemical process development and pilot plant operations in the field of solid and liquid propellants and explosives.

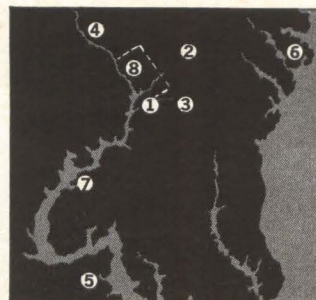

8. Naval Observatory Washington, D. C. 20390

—continued fundamental observations of positions and motions of celestial bodies . . . basic research in positional astronomy, astrophysics and celestial mechanics . . . determination of precise times and frequencies . . . control of world-wide Department of Defense distribution systems for time and frequency . . . computing and publishing astronomical ephemerides and catalogs.

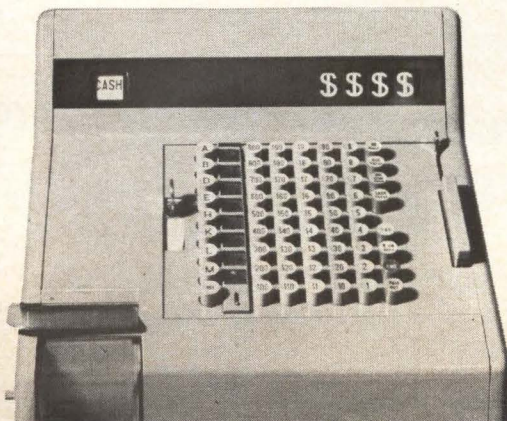

*An Equal Opportunity Employer



difficult installations made easy

The long continuous lengths of HELIAX® coaxial cable make any type of installation possible. Whether across a vast ravine or up the tallest tower, the installed cost is less. Corrugated inner and outer conductors absorb all stress. Andrew connectors firmly anchor both conductors to eliminate electrical problems. Consult your Andrew sales engineer or write Andrew Corporation, P. O. Box 807, Chicago, Illinois, U.S.A. 60642.

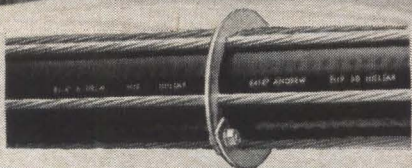

870-foot self-supporting catenary installation of 5-inch HELIAX air dielectric coaxial cable (Type HJ9-50) at mountain top site of Station KBYU-TV, Provo, Utah.

Andrew
CORPORATION

29 YEARS OF ENGINEERING INTEGRITY

10-66

IN EUROPE: Andrew Antenna Systems, Lochgelly, Fife, Great Britain

Newsletter from Abroad

January 23, 1967

British look into telecommunications equipment buying . .

The Labor government plans to probe into the relations between Britain's top telecommunications makers and their main domestic customer—the General Post Office.

GPO traditionally buys most of its telecommunications gear from five companies under an arrangement that looks much too clubby at a time when sentiment against monopolies is building up in Britain. Each of the five major suppliers virtually has a segment of the industry all to itself and the Post Office buys under "bulk supply agreements", with negotiated prices rather than open competitive bidding.

Although the arrangement eliminates expensive duplication in research and development, the government has assigned its Industrial Reorganization Corp. to see how the GPO might get better deals on telecommunications equipment from its suppliers. IRC will tackle the possibility of setting up competitive bidding—soon to go into effect for subscribers sets—for telephone exchange equipment. Britain already has started to switch to electronic exchanges [Electronics, Jan. 9, p. 254].

The Post Office has been buying some \$475 million of telecommunications equipment annually but expects its spending to rise to more than \$560 million over the next few years. The five companies that have this market largely to themselves are The Plessey Co., Associated Electrical Industries Ltd., the British General Electric Co. (not affiliated with GE in the United States), Standard Telephones and Cables Ltd., a subsidiary of the International Telephone and Telegraph Corp., and the Telephone Manufacturing Co., one of the companies in the group controlled by Pye of Cambridge Ltd. Pye currently is the object of a takeover battle.

. . . as Philips hits snag in bid to buy into suppliers club

Holland's electronics giant, Philips Gloeilampenfabrieken NV, may be blackballed in its attempt to join the British telecommunications makers' "club" through a takeover of Pye of Cambridge Ltd.

Through a British subsidiary, Philips has been vying with Thorn Electrical Industries Ltd. for control of Pye, an important producer of telecommunications equipment and television receivers [Electronics, Dec. 26, 1966, p. 166]. After Thorn had topped Philips' initial bid, the Dutch concern late last month said it would up the ante.

Since its first informal offer, Philips has acquired 20% of Pye's outstanding shares. The London Stock Exchange wants the company to disclose the source of this holding, which Philips insists wasn't purchased on the open market.

Philips needs British Treasury approval to make a formal offer for Pye. Although Treasury officials aren't commenting, there's considerable speculation that the government is reluctant to let a major Post Office supplier pass over to foreign control. Thorn is holding off until the Treasury decides what to do, but it almost certainly will renew its attempts to take over Pye when the situation clears up.

Hayakawa considers making own IC's

The Hayakawa Electric Co. is taking a hard look at the possibility of producing integrated circuits for its own use. The company now has negotiations under way to acquire IC licenses and knowhow. If the negotiations pan out, Hayakawa may be turning out IC's next year and thus almost certainly become the first Japanese company not now in the tran-

Newsletter from Abroad

sistor business to try its hand at IC manufacture.

Even with in-house IC production facilities, Hayakawa presumably would remain a big buyer of IC's from outside suppliers. Hayakawa, the top Japanese producer of desk calculators, plans to put IC versions on the market starting this year. For them it will buy standard transistor-transistor-logic circuits from Mitsubishi Electric Corp. and metal-oxide-semiconductor IC's from Nippon Electric Co. Hitachi Ltd. is also developing a line of MOS circuits for Hayakawa.

Hayakawa undoubtedly will depend, too, on outside suppliers for most of the linear circuits it will need for entertainment receivers and most likely limit its in-house production to special IC's.

Swedish spending plans endanger defense projects

Military electronics producers are jittery over the slowdown in defense spending the Swedish government has proposed in its draft budget for the upcoming fiscal year. **Instead of slating the usual 2.5% increase, the budget holds the line on defense spending at essentially the current fiscal year's level—\$1 billion.**

Defense procurement officials maintain there'll be no cutbacks on hardware already ordered. But the long-range outlook is bleak. According to Lt. Gen. Lage Thunberg, commander of the country's air force, the proposed slowdown would mean a slash in Sweden's kingpin defense project—the Viggen-37 all-purpose supersonic aircraft [Electronics, Dec. 26, 1966, p. 99]. Thunberg says the number of planes in the program would have to be cut from 700 to 400, and that no funds would be available to install the \$8 million of radar and communications equipment already ordered for the Viggen air-defense network.

Along with the air-defense cutbacks, the budget would reduce electronics spending by the army and navy. The army would get fewer ground-to-air missiles and the navy's testing of coastal and seaborne missiles would likely be dropped. A planned expansion of a central defense communications network also would be put off.

Even more ominous in the long run is the prospect of a new defense policy for Sweden, which since the late 1950's has emphasized air defense and sophisticated electronics. Defense Minister Sven Andersson hinted this month that the government may concentrate on building up conventional ground forces in the future.

Addenda

A proposal for a joint communications satellite project was discussed by officials of West Germany and France this month as Chancellor Kurt Georg Kiesinger and President Charles de Gaulle held their top-level talks . . . Tokyo Shibaura Electric Co. this April will start marketing six types of diode-transistor-logic circuits and nine types of transistor-transistor-logic IC's. Propagation times are 50 and 6 nanoseconds, respectively . . . The Westinghouse Electric Corp. plans to substantially expand semiconductor-production facilities at the Le Mans plant of its French subsidiary. The company will concentrate on increasing output of rectifiers and high-power semiconductors, but has no plans to produce integrated circuits . . . General Electric, which has been having computer problems [Electronics, Jan. 9, p. 242], has appointed J. Stanford Smith, a vice president, to take charge of its worldwide computer operations.

FMC's new CAPER process
(continuous ammonium persulfate etching & recovery).

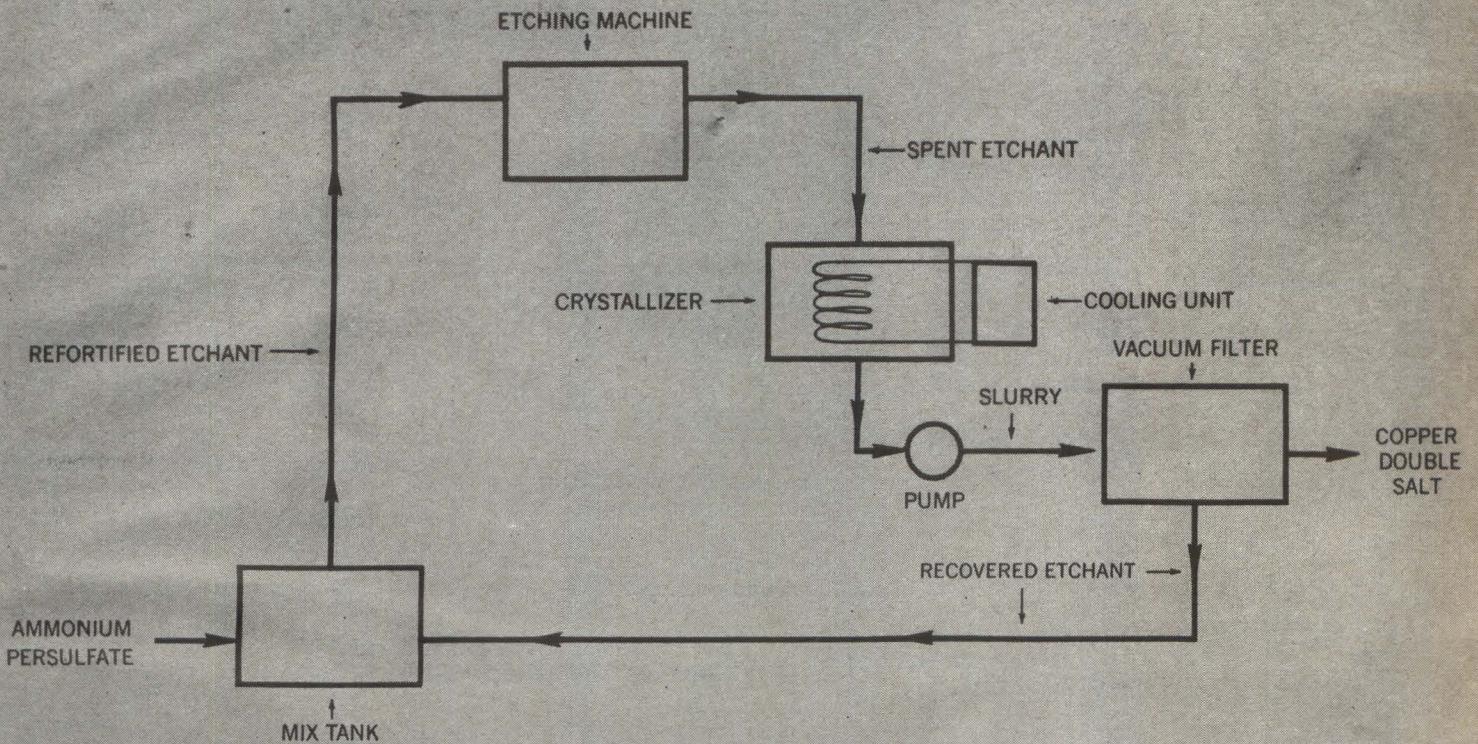

What continuously etches circuit boards
at a constant rate without waste disposal problems?

(It also cuts your ammonium persulfate etchant costs in half.)



For further information about this new process, contact our Product Promotion Department,
FMC CORPORATION, INORGANIC CHEMICALS DIVISION, 633 Third Ave., New York, N.Y. 10017.

DESIGNER'S

P. R. MALLORY & CO. INC., INDIANAPOLIS, INDIANA 46206

New space-saving switch now available on Mallory carbon controls

A new kind of rotary switch, with flat configuration, can now be supplied on Mallory carbon controls for applications where back of panel space is limited. From front face of the mounting bushing to tip of the terminals, the total back-of-panel depth of a Mallory LC single control with the new switch measures only 0.798"—compared with 1.00" for the usual single LC control-switch combination.

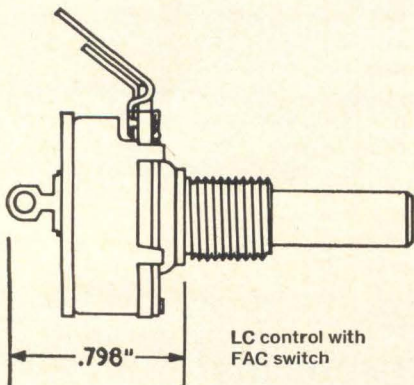
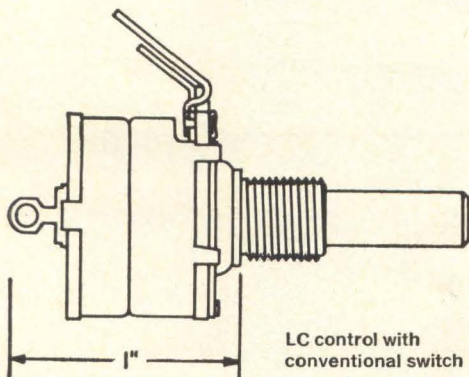

The new switch is rated 3 amperes at 125 VAC, and is presently available in the SPST design. It has UL approval. Price is slightly lower than that of the standard Mallory "O" ring switch. The FAC switch can be supplied on all standard Mallory LC series controls.

CIRCLE 106 ON READER SERVICE CARD

Reliability Report on Mallory Wet Slug Tantalum Capacitors

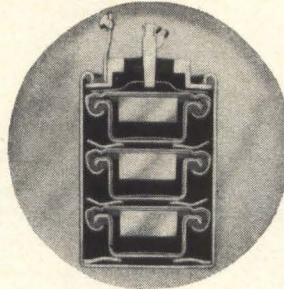

Cutaway view of 3-cell Type XT capacitor
U.S. Patent 3,275,902

Ever since we started making wet slug tantalum capacitors 17 years ago, we have been accumulating data on their reliability. At latest count, we had over 22 million piece-

hours of testing for this product line on which to base evaluation of reliability.

The incidence of catastrophic failure has been exceptionally low. This quality is an inherent property of the wet slug construction, which provides a self-healing capability.

The data shown on the chart represents a summary of test programs to date on several Mallory wet slug types. We will be glad to supply detailed test records on specific capacitor models. And we welcome your personal inspection of our manufacturing, quality control and life test facilities.

CIRCLE 105 ON READER SERVICE CARD

SUMMARY OF RELIABILITY DATA MALLORY WET SLUG TANTALUM CAPACITORS

Capacitor Type	Test Conditions Temp.	Volts	Total Unit test hrs.	Failures (catast.)	Failure rate: % per 1000 hrs.*	Mean time between failures: hours*
MTPH	85°C	Rated	6,214,300	1	0.032	3 x 10 ⁶
TLS	85°C	Rated	832,750	0	0.11	0.9 x 10 ⁶
	125°C	67% Rated	697,650	1	0.29	0.32 x 10 ⁶
All XT Series	85°C	Rated	8,291,100	6	0.09	1.1 x 10 ⁶
	175°C	67% Rated	7,361,200	7	0.11	0.9 x 10 ⁶

*60% confidence level

Matched dual controls for stereo systems

For the leading manufacturers of stereo equipment, we have been producing dual volume controls whose resistance tapers are closely matched throughout the audible range of the control. Single-knob control of both stereo channels simultaneously becomes practical, with perfect tracking of both amplifiers without need for adjustment of a clutch coupling the control sections.

This simplification of stereo adjustment is made possible by the refined production control procedures which

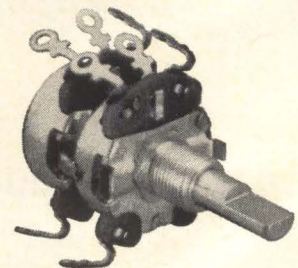

Mallory applies to the manufacture of carbon control elements. We were the first to make dual controls which tracked within 2 db, from 0 to -50 db, and are now producing matched controls in a variety of tapers for audio equipment—including the lower resistance values used in solid-state circuitry.

CIRCLE 107 ON READER SERVICE CARD

Dual trigger diode generates voltage peaks for SCR circuits

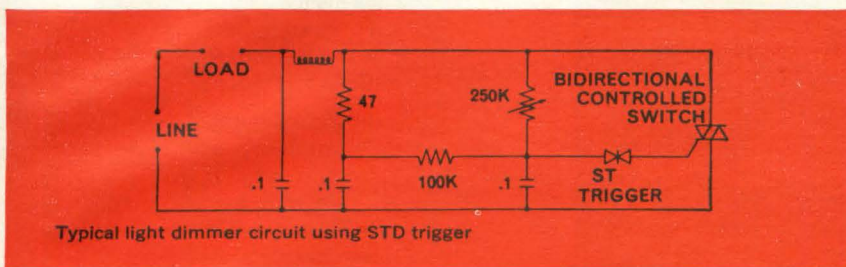
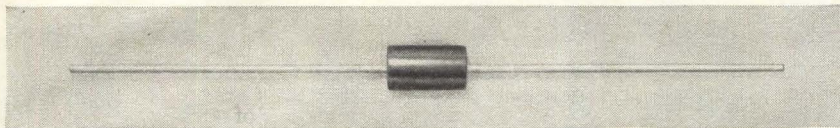

The Mallory STD dual trigger diode is a symmetrical three-layer avalanche diode which has many applications in activating SCR's and bi-switches. It's somewhat like two zener diodes connected back to back. When you apply AC to it, it allows current to pass only during that part of each half cycle when applied voltage exceeds its firing voltage. Thus it produces impulses, whose phase can be readily controlled, to switch the SCR on at different points in the cycle.

The STD has a symmetrical switching mode, as shown by the typical

characteristic curve. At voltages beyond the breakover point, its resistance decreases rapidly; this "snap back" characteristic affords improved stability of control in the SCR circuit.

The STD comes in molded case only .375" long by .200" in diameter. It is rated 1 watt average at 50°C ambient. It can handle 1.0 ampere peaks of 20 microseconds duration on a 0.5% duty cycle. Standard breakover voltage ratings go from 24 to 120 volts, in standard tolerance of $\pm 10\%$. Symmetry of breakover voltage is within 5%.

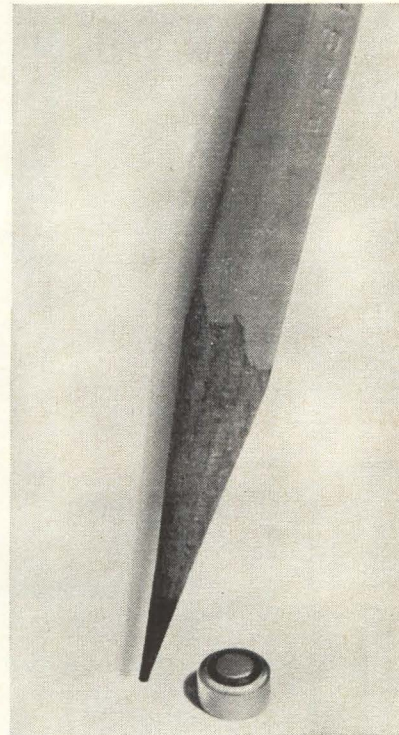

Miniature cells for Microcircuits

Circuits have shrunk and now so have batteries—but that doesn't mean that efficiency suffers in the least. The new Mallory mercury batteries in sizes to complement integrated circuits retain their extraordinary high energy density. Performance, if anything, is improved.

Miniature Mallory mercury cells are now available to power everything from hearing aids to ordnance devices. Capacities range from 16 MAH to 160 MAH, sizes from 0.225" to 0.450" diameter.

(See Table below.)

	RM-212	RM-312	RM-575	RM-675
CAPACITY MAH	16	36	100	160
RATED DRAIN MA	.75	2	3	5
DIA. (IN.)	.225	.305	.450	.450
HT. (IN.)	.130	.135	.130	.200
WT. (OZ.)	.01	.02	.05	.09

TYPICAL TRIGGER CHARACTERISTIC

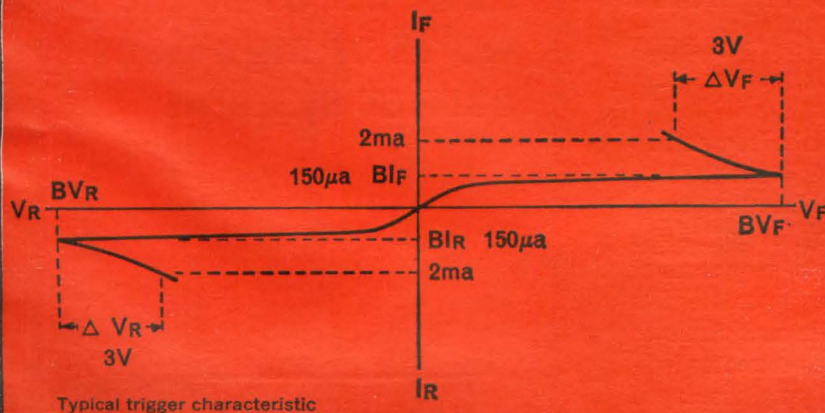

CIRCLE 108 ON READER SERVICE CARD

CIRCLE 109 ON READER SERVICE CARD

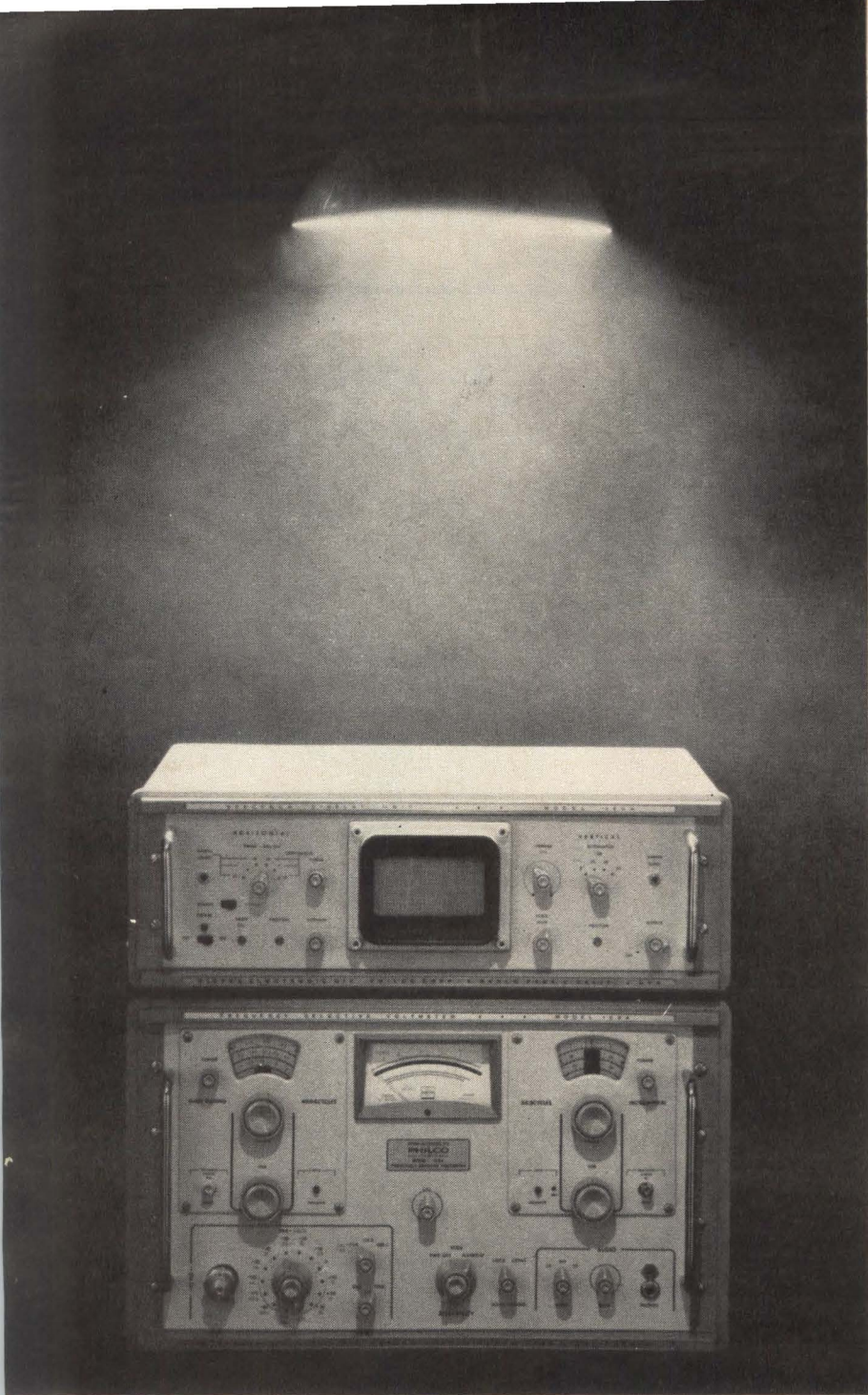

Sierra brings to light...

You'll spot them all with lightning speed on Sierra's Model 360A Spectrum Display Unit: Overload, noise, crosstalk, carrier leak. The communications disrupters!

Tracking automatically across the tuning range of a companion frequency selective voltmeter (shown above, Sierra's Model 128A), Model 360A presents an expanded view of selected frequency segments on a high-resolution, swept-band CRT display. Sweepwidths of 120 kHz or 12 kHz display thirty- or three-channel segments of the multiplex baseband. A 3.6-kHz sweep position narrows the view to one voice channel, resolving approximately 30 Hz at 3 db down from a carrier peak and 60 Hz at 40 db down. The voltmeter indicates precisely the frequency and amplitude of any displayed signals.

Price of the Model 360A is \$2,450. The bulletin sheds further light on the matter. Write Sierra, 3885 Bohannon Drive, Menlo Park, California 94025.

Circle 232 on reader service card

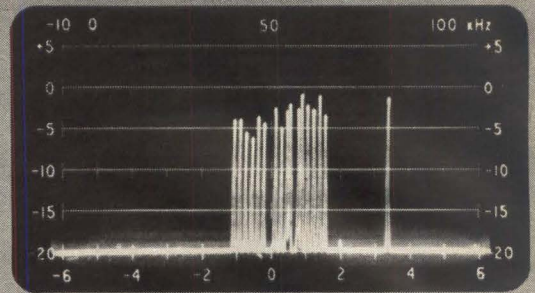

Three L-3 carrier channels shown in 12-kHz sweep width mode: teletype signals on center channel, 2600-Hz "on hook" tone on right channel, left channel idle.

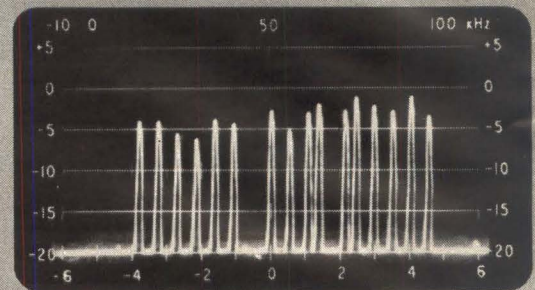

Center channel above expanded to 3.6-kHz sweep width mode: 17 teletype carriers, 1 missing, 2 showing "mark-space" information.

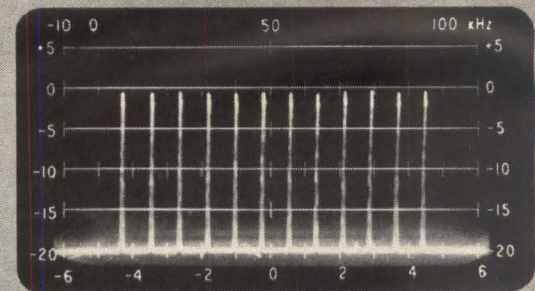

Complete N-1 carrier system shown in 120-kHz sweep width mode. Slope is 0 db, all carriers present, channels 2-13, high group.

dark deeds in the under-world of high-density carrier systems

PHILCO



PHILCO-FORD CORPORATION
Sierra Electronic Operation
Menlo Park, California • 94025

Great Britain

Bulk IC's

So far, researchers working with bulk semiconductors have concentrated largely on developing such microwave devices as Gunn-effect oscillators. But it may turn out that they've overlooked a much better bet—bulk-effect monolithic circuits.

At next month's International Solid State Circuits Conference in Philadelphia, C.P. Sandbank of Britain's Standard Telecommunications Laboratories Ltd., an affiliate of the International Telephone and Telegraph Corp., will report on some experimental integrated circuits that point to a completely new class of devices. Instead of interconnected active and passive elements laid down on a single semiconductor chip, Sandbank's circuits depend on bulk effects to generate complex electronic functions.

Sandbank calls the new circuits domain-originated functional IC's. In them, stable high-field domains travel along drift paths that are long compared to the width of the domain. The circuit function depends on the characteristics of the drift path. As the domain, driven by a constant-voltage source, transits an IC, the instantaneous current varies according to the "conduction profile" of the path.

Fast and slow. The domain can transit over a wide range of speeds. When produced by field trapping, the domain pokes along at less than 1 centimeter per second. With electron-phonon coupling, however, it moves at the speed of sound; and inter-valley transfer of hot electrons produces domains that transit at speeds up to 10^7 cm/sec.

Along with transit speed, the current-time characteristic of the domain-originated IC can be shaped by tinkering with the drift path

in any of several ways. An obvious method is to vary the cross-section of the drift path; another is to vary the doping in the semiconductor. The conduction profile also changes when light is beamed on different parts of the drift path or when local impact ionization of deep donors occurs. Still another possibility is local application of electric fields through electrodes close to the drift path.

Electrodes also can be used to pick off voltage waveforms from the monolithic circuit. Optical readout is possible too, suggesting the eventual use of the domain-originated IC for video scanning and display.

Converter. An example of how a domain-originated IC can be tailored to develop a desired function is the analog-to-digital converter circuit shown. In it, the conduction profile of the drift path is established by etching an epitaxial layer laid down on a gallium-arsenide substrate. The serrations set the digital code, and the analog

characteristic is a function of the overall taper of the drift path. Since the domain travel depends on the amount of bias applied, the number of digits read out corresponds to the analog voltage.

In the family

Like any with-it communications equipment maker, the Plessey Co. opted for integrated circuits a year ago when it started development of a mobile single sideband transceiver for the Ministry of Aviation. But when Plessey completed its design, it found it had not only a transceiver but also a compatible family of IC's for military and professional communications systems.

The Plessey family of IC's includes a radio-frequency amplifier with 150-megahertz bandwidth, an intermediate-frequency amplifier, an audio-frequency amplifier, a diode ring for modulators, and automatic-gain-control generators

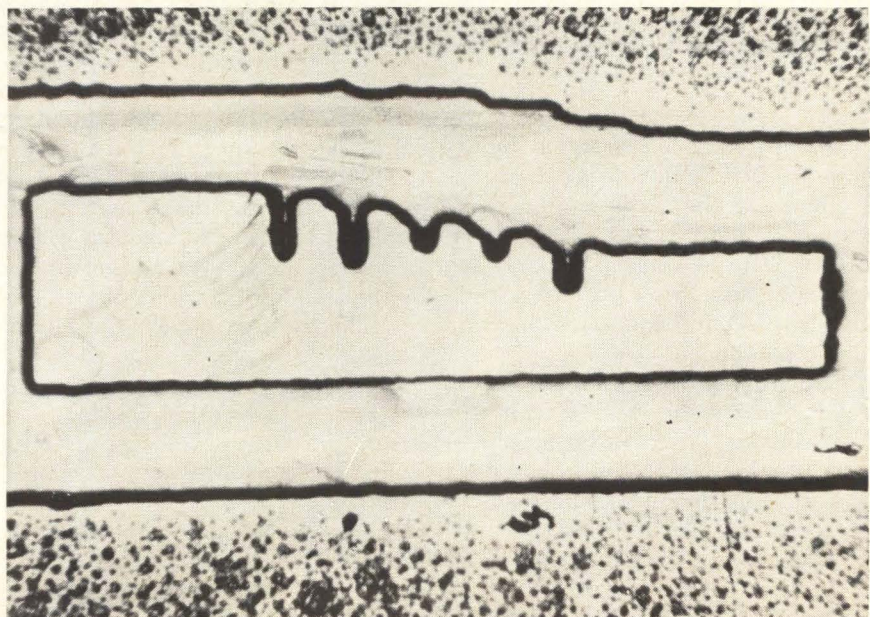

Analog-to-digital conversion is just one of many complex electronic functions that can be obtained by varying the drift path in a domain-originated monolithic circuit. In this converter circuit, the over-all taper sets the analog characteristic and the serrations the digital code.

for single sideband use and for microphone amplifiers. Plessey's ic family planning calls for adding a limiting intermediate-frequency amplifier and a transformerless double-balanced modulator to the circuits already developed.

In its transceiver ic's, Plessey aimed for low power consumption and hit the mark. The i-f amplifier, for example, gives a voltage gain of 50 but consumes only 15 milliwatts from a 6-volt supply. The audio amplifier's quiescent consumption is just 20 mw, about a sixth of the maximum allowed in the specifications for the transceiver.

Despite low consumption, the circuits outperform their discrete-component predecessors. The r-f

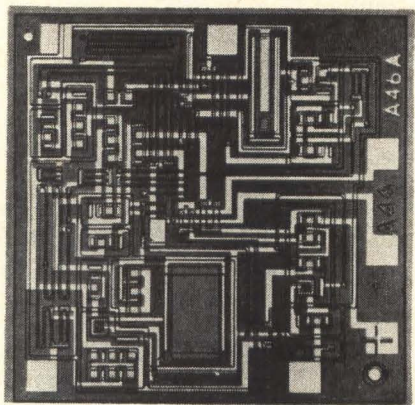

Same chip serves for both single sideband agc generator and vogad in Plessey's family of integrated circuits for military transceivers.

amplifier can handle signal inputs up to 200 millivolts root-mean-square and the audio amplifier has an agc range better than 90 decibels. The ic single sideband agc actually has fewer elements than its conventional equivalent has discrete components.

All-around. Still another family characteristic of Plessey's circuits is versatility. The audio amplifier, for example, operates either as a headphone or microphone amplifier. The single sideband agc generator and voice-operated gain-adjusting device (vogad) are both obtained from the same basic chip. The agc generator gets its input from the input to the headphone amplifier and develops a control

output for the r-f and i-f amplifiers. As a vogad, the circuit controls the microphone amplifier.

The circuits were developed at Plessey's Allen Clark Research Centre by a team headed by M.J. Gay. Gay and his co-workers will report in detail on their ic family next month at the International Solid State Circuits Conference in Philadelphia.

Edgewise entry

British electronics manufacturers long maintained they could make headway in the United States market for military hardware if the Pentagon relaxed its "Buy American" policies. The success of Elliott-Automation Ltd., particularly, is bearing out their contention.

Elliott this month landed a pair of contracts for electronics gear destined for the Air Force's giant C-5A transport. The contracts, along with an earlier one for an air-data computer, bring to \$4.5 million the business Elliott will get from the C-5A. In addition, the company has a contract to develop a "head-up" display for the Navy's Corsair-2 carrier aircraft [Electronics, Sept. 5, 1966, p. 199].

Foothold. All the contracts come under the Anglo-American agreement in which the Pentagon agreed to waive "Buy American" rules for some \$300 million of British equipment to offset the cost of 50 F-111 intercontinental fighter-bombers Britain will buy from the U.S. But Elliott feels it now has a foothold in the U.S. military market that will outlast offset. Says an Elliott official, "Once you're inside the door, nobody mentions offset."

Elliott's two latest C-5A contracts cover an analog computer for fuel management and a control system to swivel the plane's undercarriage during landings in crosswinds. The control system swivels the main undercarriage legs and the nosewheel into line with the runway as the plane comes in crabwise to correct for drift. Shortly after touchdown, the system automatically swings the fuselage back into alignment with the undercarriage. The amount of swiveling be-

fore landing is controlled by the pilot.

Fuel watch. The fuel management computer is designed to keep the crew up-to-date on the range of the plane under a variety of flying conditions. The computer, which takes up less than half a cubic-foot of space, is fed continuous inputs of airspeed, fuel consumption, altitude and air temperature. The crew cranks in cargo weight, fuel weight and aircraft operating weight. From these inputs, the analog computer determines optimum speed and engine pressure ratio for either a cruise climb, constant-altitude cruise or best endurance.

Japan

In the groove

Like Broadway dolls, audiophiles have little esteem for synthetic sapphires. For high fidelity, they insist a diamond stylus is a record player's best friend.

But synthetic sapphires may take over as the stylus material in all but expensive hi-fi sets because of a discovery by the Tokyo Shibaura Electric Co. (Toshiba). The company has found a way to make a low-cost sapphire stylus that lasts almost as long as a diamond one.

Toshiba's new stylus takes advantage of a phenomenon diamond cutters discovered long ago: rub a diamond face the right way and it can be polished; rub it the wrong way and practically nothing happens. The same anisotropic wear characteristics hold for synthetic sapphires and the key to the long life of Toshiba's stylus is simply putting the wear-resisting rubbing directions in contact with the record groove.

With the right crystal orientation, a stylus holds its 0.7-mil spherical radius several times longer than a conventional sapphire stylus. In tests on the same record, an ordinary stylus showed a flat developing on the point after eight hours of use. After 24 hours, the stylus had worn enough to

start damaging the record. The oriented-crystal stylus, by contrast, still showed a spherical point after 176 hours of playing.

X-rayed. Production of the new stylus starts with a single-crystal rod of synthetic sapphire, the same material used in a conventional sapphire stylus. The longitudinal axis of the rod coincides with an "easy" direction of crystal growth and is inclined from 50° to 80° to the vertical axis of the crystal. Since the crystal orientation varies from rod to rod, each has its exact structure checked by X-ray diffraction. Then the rod is sawed so that the stylus has a long-wear orientation when it is mounted in its holder.

Toshiba already is using the new stylus, called Ultra-C, in a portable radio-phonograph. Because of its low cost, Toshiba sees a bright future for the stylus in medium- and low-quality record players. Nagaoka Seiki Hoseki Kogyo K.K., a Japanese phonograph-needle maker, is mass-producing the Toshiba stylus.

Startling stripes

At first glance the term "monocolor" seems self-contradictory. But engineers at the Japan Broad-

casting Corp. (NHK) and the Nippon Columbia Co. have figured out a way to record motion pictures on black-and-white film for telecasting in color.

The quality of the monochrome images doesn't match that of telecasts based on regular color film, but NHK expects the faster photo-processing speed and lower costs afforded by monochrome to win the new system a place in spot news colorcasts. And Nippon Columbia, which has developed a live monochrome camera as well as a film version, sees a large potential market in closed-circuit tv systems for the live camera, which is less expensive than conventional cameras because it uses only a single pickup tube.

Filtered. To pack onto 16-millimeter black-and-white film enough information to produce a color picture, the monochrome system uses a pair of striped filters fitted in the camera's optical system tight against the film. One set of stripes, each 21 microns wide, passes only green and red light. The other set of stripes, 27 microns wide, passes only green and blue light. In each filter, the colored stripes alternate with transparent stripes; the two filters are stacked one on top of the other and sandwiched between

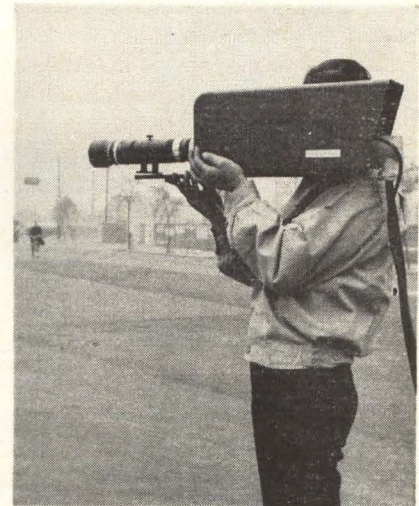

Single-tube color tv camera developed by Nippon Columbia Co. registers blue and red chrominance information as black-and-white stripes.

fiber-optic faceplates. With this arrangement, stripelines with red and blue color information are obtained on a black-and-white film. Green light passes through to the film unmodulated and forms the basis for a luminance signal.

Scanned. The developed monochrome film with the color-information stripes is projected onto a 1½-inch vidicon camera tube. When the image is scanned, a luminance signal (the unmodulated green plus the mean values of red and blue) with a bandwidth of 2.8 megahertz is obtained. Because of the stripes, a blue subcarrier centered at 3.3 Mhz and a red subcarrier centered at 4.25 Mhz also are picked up.

The output of the vidicon tube is fed to a pair of bandpass filters to separate out the subcarriers, and through a lowpass filter to extract the luminance signal. All three video-signal components are then fed to a matrix that extracts the green signal from the luminance signal. Through this process, the striped black-and-white image thus yields all four components required for a color-tv signal: luminance, red, blue and green.

Vidicon cameras in general have a poor signal-to-noise ratio at high frequencies, and the chrominance channels in the monochrome system are high-frequency subcarriers. To improve the ratio, a Percival circuit is used for the first stage of



Colorful stripes. Pair of striped filters puts three-color image on black-and-white film. Projected on a vidicon tube and scanned, stripes generate chrominance subcarriers for red and blue channels. Green is extracted from luminance signal.

the camera amplifier. Also, a deflection-correction signal is superimposed on the horizontal deflection signal to increase linearity.

Switched. The prototype live monochrome camera produces a better picture than the film version largely because there's more image area on its 1½-inch vidicon tube than on a 16-mm film frame. Both the filter stripes and the video-signal bandwidths can thus be wider.

The luminance channel extends to 3.5 Mhz; the red channel appears on a subcarrier at 4.5 Mhz and the blue channel at 6.5 Mhz. Because the live camera is intended primarily for daylight use, its chrominance channels were switched. With adequate light, the noisier higher-frequency channel is best for blue light since the human eye is less bothered by noise effects in blue hues. But for the film version of the monochrome camera, which often will be used with tungsten light, the lower-frequency channel is used for blue to increase the sensitivity of the camera.

West Germany

The right sort

Every day, some 30 million letters stream through West Germany's postal system. To cope with the

flood of mail, which rises 7% each year and swells to nearly 60-million items daily during the Christmas season, German postal authorities are increasingly turning to automation in a long-range modernization program.

The latest addition to the German arsenal of mail-sorting systems is an installation that sorts 21,600 letters an hour for 100 destinations. Currently under test at the Weisbaden post office, the sorter is the fastest of three systems now operating in Germany.

Fluorescent. Standard Elektrik Lorenz AG, a subsidiary of the International Telephone and Telegraph Corp., developed the Weisbaden system. In it, a conveyor feeds outgoing letters to seven coding desks, each with a typewriter-like keyboard. As a letter passes through a coding desk, the operator punches in the postal area code, the German equivalent of the ZIP code used in the United States. A proficient operator can encode 5,000 letters an hour.

The code signals generated by the keyboard unit are stored in a 20-bit register until the letter reaches a fluorescent-ink printing unit. Then, the code signals actuate the printer, which marks the envelope with vertical fluorescent marks in a two-of-five code.

At the sorting bins, a scanner reads the fluorescent marks, and a translator converts the scanner's output into signals that release the letter from the conveyor at the proper bin.

Expansion plans. The SEL system was designed so that its capacity could be increased to 200 destinations. And it could be fitted with SEL-built letter-facing gear that orients letters so that the address is right-side up, ready for automatic feed by conveyor belt to the coding desks.

This facing equipment, already in use in the U.S. and Europe,

Operator punches postal area code on typewriter-like keyboard as letters pass through coding desk. Signal is stored in register until letter reaches printing unit that puts fluorescent-ink code marks on envelope.

searches for the stamp and once it locates it, positions the letter. Looking ahead to the time when the facing equipment will be added to German automatic sorting centers, postal authorities there have already switched to fluorescent stamps that can be spotted by the scanning heads of letter facers.

France

Atomic impetus

The agency that has masterminded France's drive toward independence in everything nuclear—from power stations to hydrogen bombs—is pushing the French electronics industry to the fore in nuclear instrumentation.

The agency, Commissariat à l'Énergie Atomique, spends about \$40 million a year on electronics, mostly new equipment developed under its own contracts. CEA is a demanding customer, and for that very reason equipment turned out by French nuclear instrumentation firms is increasingly finding export markets.

French electronics companies are unstinting in their praise of CEA. Jacques Raux, technical director of La Radiotechnique-Coprim-RTC, attributes his company's considerable achievements in the nuclear field largely to the agency. Says Raux: "The CEA defines the performance and other standards to meet. They're always the highest standards, and that's what helps us most."

The recent history of RTC, a components-producing affiliate of Philips Gloeilampenfabrieken of the Netherlands, affords a prime example of the impact CEA has had on the industry. Photomultiplier tubes originally developed for CEA have become one of the company's most successful product lines. Raux says RTC exports 50% of the photomultipliers it produces, and that 55% of these exports go to the United States.

Rectangular. RTC's latest photomultiplier tube, also the fruit of collaboration with CEA, is an espe-

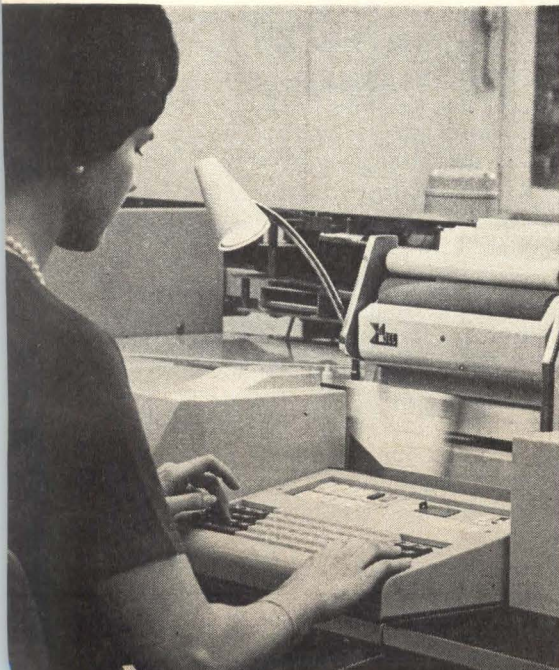

Design a new circuit? It only takes 10 seconds to find out that maybe you didn't.



Polaroid Land film for oscillography is as quick to point out a mistake as it is to point out a success.

You never have to wait for darkroom development only to find out that your new breadboard needs more work.

You get your results in 10 seconds flat. And it's always a sharply detailed, high-contrast trace recording.

You can study it, attach it to a report, send it as a test record along with a product shipment, or file it for future use.

Choice of films? Yes. There are four different films for oscilloscope recording in pack, roll, and 4 x 5 formats.

The standard film speed has an ASA equivalent rating of 3000.

If you want to take a picture of a trace so fast you can't even see it, we've got a

special film called Polaroid PolaScope Land film with an ASA equivalent rating of 10,000. It's the fastest film around. It will actually record a scintillation pulse with a rise time of less than 3 nanoseconds.

To use these films on your scope, you need a camera with a Polaroid Land Camera Back. Most manufacturers have them (Analab, BNK Associates, Coleman Engineering, EG & G, Fairchild, General Atronics, Hewlett-Packard, Tektronix).

You can get complete details from one of these manufacturers, or by writing to Polaroid Corporation, Technical Sales, Dept. 30, Cambridge, Massachusetts 02139.

Polaroid Land Film for Oscilloscope Trace Recording

Your plant may be ready for new electronics equipment...

but how about your people?



Every day more sophisticated electronic equipment is used by more companies to perform more critical operations. Computers. Calculators. Control systems. Process instrumentation. Communications equipment. It's highly efficient... as long as you have qualified electronic technicians who understand it, know how to maintain it... and can fix it fast if it ever fails.

A good way to build a competent staff of skilled electronics technicians is to up-grade your present technical personnel. And a good way to do it is with a Cleveland Institute of Electronics Training Program. CIE "AUTO-PROGRAMMED" Courses are fast, effective and economical. What's more they can be "tailored" to your specific training needs. There are other advantages, too... and hundreds of satisfied users. Learn about them. Send coupon today for FREE details. Cleveland Institute of Electronics, Dept. E-26, 1776 E. 17th St., Cleveland, Ohio 44114.

SEND COUPON TODAY

Cleveland Institute of Electronics

Dept. E-26, 1776 E. 17th St., Cleveland, Ohio

Gentlemen: I am interested in learning more about your Electronics Home Study Programs. Please send complete information.

Name _____

Title _____

Company _____

Address _____

City _____ State _____ Zip _____

Accredited Member, National Home Study Council.

Electronics Abroad

cially rugged one designed for French satellites and missiles. The company guarantees it against sinusoidal vibration from 20 to 2,000 hertz at accelerations to 30 g's, shocks up to 11 milliseconds long at 100 g's, and centrifugal acceleration forces up to 45 g's. To achieve the necessary mechanical rigidity, the electrodes are soldered on heavy parallel bars and the dynode connections through the glass housing of the tube are rugged metal conductors. For this tube, which has a gain of 10 million and a rise time of 3 nanoseconds, RTC uses a rectangular glass housing for rigidity and ready installation in space-tight equipment.

Along with its photomultiplier tubes, the concern produces semiconductor detectors that Raux says match U.S. devices in performance. RTC's new photomultipliers and detectors provide CEA with all-French nuclear spectrometry instrumentation for the first time.

CEA has to turn to U.S. companies only for the most sophisticated hardware, such as integrated circuits. Of the agency's \$40 million annual electronics outlay, 95% goes to French suppliers. Less than a third is spent on standard catalog items; most of the rest goes for new equipment developed at CEA's behest.

International

Satellite forecast

Europe still has some years to go before orbiting its own communications satellite but its space technology is already far enough along that aerospace companies are looking at the economics of space communications.

Early this month, ESRO 2, the first scientific satellite of the European Space Research Organization, was dispatched from London to the United States for a scheduled March 1 launching from the Western Test Range. Geoffrey Pardoe, technical sales manager of Hawker-Siddeley Dynamics Ltd., the prime contractor for the satellite,

took the occasion to expound the company's thinking on future European satellite development.

Hawker-Siddeley feels that regional European space communications systems are now technically practicable and would be cheaper to build in most cases than networks using submarine cables or complex microwave links. And the company thinks a direct-broadcasting television relay satellite would turn out a money saver.

Four channels. Pardoe points out that the British Space Development Co. estimates that it would cost about \$340 million to provide four new conventional tv channels to cover Great Britain. By direct-broadcasting satellite, the same four channels would cost \$140 million, according to British Space. The sum would cover development of a single-channel satellite and putting four of them into operation.

Theoretically, the satellite would need only a 2° beamwidth to cover all of Britain; but to compensate for stabilization errors, a 35-foot diameter erectable antenna with 3° beamwidth would be used.

A possible frequency for transmission would be 850 megahertz and the electronics would be powered by 8 kilowatts generated by a solar cell array. To pick up the satellite broadcast, home receivers would need an antenna 3 feet in diameter plus a transistorized pre-amplifier. Pardoe thinks such a satellite could be orbited within four to six years. To meet that hypothetical deadline, a U.S. launch vehicle would be needed to orbit the heavy satellite.

But by 1970, Europe should have a launch vehicle capable of putting into orbit a communications satellite with as many as 5,000 voice circuits. The European Launcher Development Organization plans to develop the vehicle [Electronics, July 25, 1966, p. 230].

Around the world

France. Cie. Française Thomson Houston-Hotchkiss Brandt is ready to put on the market a four-tube color television camera. Like

AMELCO's new 807BE OP AMP has a total input offset voltage of only 3.0 mV! (-55°C to +125°C)



The 807 is the newest addition to Amelco's successful line of monolithic operational amplifiers—unsurpassed in drift performance and now available from stock at only \$45.00* in TO-5s or flat packs.

If your application demands GUARANTEED drift performance, we invite you to compare the 807 specs with any monolithic available. You won't find anything to compare with our spec limits of 50 nA INPUT OFFSET CURRENT, 5 $\mu\text{V}/^\circ\text{C}$ OFFSET VOLTAGE DRIFT, OR 500 nA INPUT BIAS CURRENT! See for yourself:

PARAMETER	CIRCUIT TYPE			UNITS
Input Offset	807BE	709A	1533	
Voltage (25°C)	2.5	5.0	5.0	mV
Voltage (-55°C to +125°C)	3.0	6.0	6.0	mV
Voltage Drift (untrimmed)	10	note	note	$\mu\text{V}/^\circ\text{C}$
Voltage Drift (trimmed)	5.0	note	note	$\mu\text{V}/^\circ\text{C}$
Current	50	200	150	nA

Note: Both 709A and 1533 list no guaranteed value for this parameter. Worst case calculations of $\frac{11\text{mV}}{180^\circ\text{C}}$ show that devices with Drift of 60 $\mu\text{V}/^\circ\text{C}$ would be in spec.

\$45.00 isn't much to pay for the world's best monolithic op amp. You'll pay three to four times that much for an equivalent module-type op amp—hardly what we'd call a bargain! Your best buy is really our 807 data sheet. It's free.

*QUANTITIES 100 AND UP

AMELCO SEMICONDUCTOR

DIVISION OF TELEDYNE, INC. • 1300 TERRA BELLA AVENUE • MOUNTAIN VIEW, CALIFORNIA • Mail Address: P. O. Box 1030, Mountain View, California • Phone: (415) 968-9241 / TWX: (415) 969-9112 / Telex: 34-8416 • REGIONAL OFFICES: Southwest—Suite 213, 8621 Bellanca Ave., Los Angeles, California 90045, (213) 678-3146 • Northwest—1300 Terra Bella Ave., Mountain View, California, (415) 968-9241 East—P. O. Box 2091, Paterson, New Jersey 07509, (201) 696-4747; 60 Broad Hollow Rd., Melville L. I. New York, (516) 692-4070; P. O. Box 366, Kimberton, Pennsylvania, (215) 885-1755 • Northeast—805 High Street, Westwood, Massachusetts, (617) 326-6600 • Southeast—711 Magnolia Avenue, Orlando, Florida, (305) 423-5833 • Midwest—650 West Algonquin Road, Des Plaines, Illinois, (312) 439-3250; 3020 Woodlark Lane, St. Paul, Minnesota, (612) 646-1161. • Canada—Deskin Sales, Montreal, Quebec, (514) 384-1420.

Cinch
Creative
Problem
Solving

to reduce gold requirements..

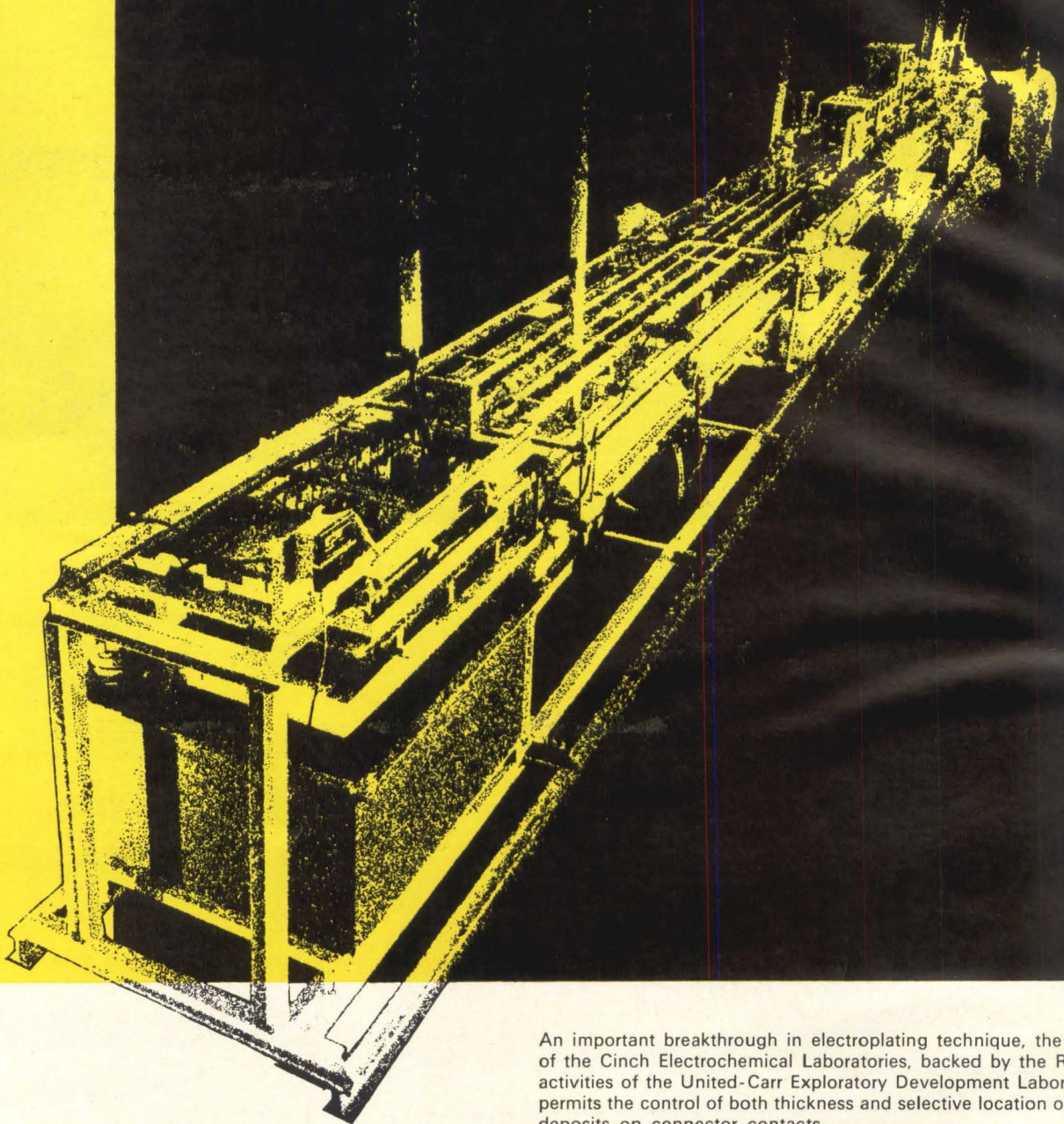

An important breakthrough in electroplating technique, the work of the Cinch Electrochemical Laboratories, backed by the R & D activities of the United-Carr Exploratory Development Laboratory, permits the control of both thickness and selective location of gold deposits on connector contacts.

RESULT: Substantial cost savings with no decrease in connector reliability, durability or electrical performance. This achievement in precious metal deposition has even greater significance when combined with Cinch capabilities in contact and insulator design.

In addition to this unique process, Cinch utilizes other, more conventional, selective plating methods, when appropriate. "Gold Button" welding is another Cinch-developed method for reduction of gold usage and connector costs.

Here is another demonstration of the extra dimension in Cinch's engineering and developmental skills. Beyond this ability to design fine products, we offer in-depth production engineering capabilities, including tool, die, mold and equipment design and fabrication.

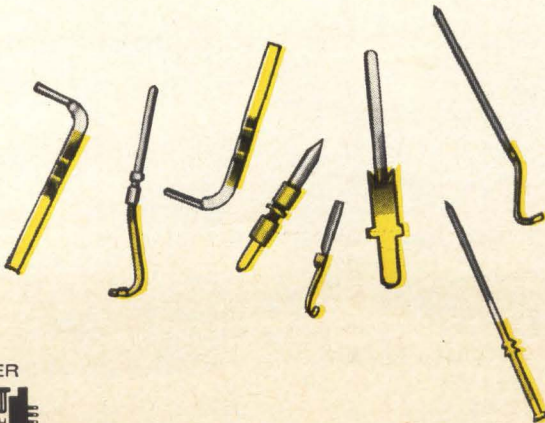

MEMBER

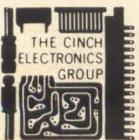

CINCH

DIVISION OF UNITED-CARR

CONSISTING OF CINCH MANUFACTURING COMPANY, CINCH-GRAFIK, CINCH-MONADNOCK, CINCH-PULASKI, CINCH-ROCKFORD, CINCH-SOUTH BEND, CINCH-TOLSON, CINCH-WASHINGTON, CINCH-WYOMING

60%

develop
a unique
selective
plating
process

Our skills and services are available to you. For Cinch creative problem solving assistance, contact Cinch Manufacturing Company, 1026 South Homan Avenue, Chicago, Illinois 60624.

Electronics Abroad

the four-tube camera of Britain's Marconi Ltd. [Electronics, Dec. 26, 1966, p. 168], the new unit uses Plumbicon color tubes developed by Philips Gloeilampenfabrieken nv of the Netherlands. The Thomson-Houston camera was developed primarily for the Secam color tv system that will be used in France, where the company has about 90% of the studio-equipment market. However, it can be adapted to both U.S. color standard and the West German PAL system selected by most Western European countries.

Great Britain. The Post Office has made a 10-year grant of \$280,000 to set up a chair of telecommunications at the recently established University of Essex. Post Office officials see the move as the first step toward a school of telecommunications that will do research and train engineers.

Japan. A driverless battery-powered tractor has been put on the market by the Shinko Electric Co. of Tokyo. Intended for transporting materials in industrial plants, it is guided by a low-voltage wire taped to the floor and a silicon controlled rectifier system in the vehicle. The control setup allows eight switch points and 14 stop stations on the tractor's chosen route, which can be up to 1.2-miles long. The tractor can haul trucks of about 6 tons in total weight at 2.5 miles an hour. It can be converted to driver-controlled operation by the moving of a lever.

Bulgaria. The Sofia city government has installed a centrally controlled timing system for its public clocks. The master clock, electronically controlled to limit time deviation to less than three seconds yearly, transmits by radio a timing pulse once every minute to secondary clocks throughout the city and surrounding suburbs. Each of the secondary clocks can be connected by wire to as many as 150 clocks in factories, public offices and the like.

Japan. Sanyo Electric Co. last week started selling two types of 19-inch color television sets at retail prices of \$452 and \$486. The company will produce 3,000 of each model monthly. Sanyo's move breaks through the \$500 minimum

retail price level the Japanese government claims was illegally set by six major tv producers, and it could weaken the government's case in an antitrust hearing scheduled for next week [Electronics, Jan. 9, p. 241].

Sweden. Radio Engineering Products Ltd. of Montreal has formed a subsidiary in Stockholm to handle sales throughout Europe and parts of Asia. The company chose Sweden as an overseas base largely because it already has sold the Swedish armed forces some \$7 million of equipment for multichannel tactical radio links and expects more Swedish business. Radio Engineering is the first Canadian electronics company to set up its European sales headquarters in Sweden.

Hong Kong. General Telephone & Electronics Corp. plans to buy control of Wireless Products Ltd., a major Hong Kong transistor-radio manufacturer, from the Amerex group of companies for stock. Wireless Products had sales of \$5 million in the year ended Nov. 30, 1966. As a General Telephone subsidiary, it will continue transistor-radio production and add other electronic products to its line.

West Germany. Next month the Max Planck Institute for Radio Astronomy will let a contract for what will be the world's largest fully steerable radio-telescope antenna. The German telescope will have an antenna diameter of 328 feet, compared to 250 feet for the Jodrell Bank facility in Britain and 300 feet for the National Radio Astronomy Observatory's installation at Green Bank, W. Va.

Great Britain. Electronic Signs & Signals Ltd. is producing a transistorized unit to power neon lamps on cars and trucks. The unit, which runs off the vehicle's battery, uses a free-running electronic circuit with a high-frequency output matched to the neon tube. The transformer is an integral part of the oscillating circuit. Power consumption for a neon tube two feet long is about 1 ampere, and the light produced has about three times the penetrating power of conventional filament lamps with equal current consumption.

Electronics advertisers

January 23, 1967

■ Acme Electric Corporation Scheel Advertising Agency Inc.	139	Consumers Power Company— Area Development McLain Advertising Incorporated	124	■ Hewlett Packard— Loveland Division Tallant & Yates Inc.	2
■ Acopian Corporation Mort Barish Associates	193	■ Couch Ordnance Incorporated Culver Advertising Incorporated	156	■ Hewlett Packard— Microwave Division Lennen & Newell Incorporated	18 & 19
■ Acromag Incorporated Watkins-Rogers Inc.	196	■ Curtis Instruments Incorporated Lescarboua Advertising Incorporated	138	■ Hewlett Packard— F.L. Moseley Company Division Lennen & Newell Incorporated	144
■ Air Products & Chemicals Inc. Arthur Falconer Associates	210	■ Dale Electronics Incorporated—sub. of Lionel Corporation Swanson, Sinkey Ellis, Incorporated	58	■ Honeywell Computer Control Division Franklin P. Folts Co.	43
■ Airpax Electronics Inc. Welch, Mirabile & Company	61	■ Delco Radio Division of General Motors Corporation Campbell-Ewald Company	20 & 21	■ Honeywell Micro Switch Division Batten, Barton, Durstine & Osborn Incorporated	72
■ Allen-Bradley Company Fensholt Advertising Agency	133 & 134	■ Deltron Incorporated Benn Associates	216	■ Hughes Aircraft Company Foote, Cone & Belding Incorporated	183 & 210 & 220
■ Amelco Semiconductor Div. of Teledyne Inc. Sturges & Associates	239	■ Dickson Electronics Corporation N.A. Winter Advertising Agency	175 to 183	■ Hull Corporation Michener Company Advertising	203
■ American Electronics Laboratories Benn Associates	215	■ Digital Equipment Corporation Kalb & Schneider Incorporated	22	■ Hysol Corporation Barber & Drullard Incorporated	174
■ Ammon Instruments Inc. Culver Advertising Agency	214	■ Dorne & Margolin Incorporated Snow & Depew Advertising	145	■ I R C Incorporated Gray & Rogers Incorporated	162
■ Amperex Electronics Corporation Div. of North American Philips Co. Sam Groden Inc.	73	■ DuPont de Nemours Company— Mylar Division Batten, Barton, Durstine & Osborn Incorporated	35	■ Image Instruments Incorporated L.K. Frank Company Incorporated	52
■ Andrew Corporation Fensholt Advertising Inc.	226	■ Eastman Kodak Company— PCIM Market Development Rumrill-Hoyt, Incorporated	113	■ Imtra Corporation S. Gunnar Myrbeck Company	217
■ Atlas Chemicals Industry Inc. Harris D. McKinney Inc.	184	■ Electro Craft Fischbein Advertising Incorporated	186	■ INEL 1967 Mosse Annoncen A.G.	204
■ Automatic Electric Company sub. of Gen. Tele. & Electronics Corp. Tatham-Laird & Kudner Incorporated	169	■ Electrical Industries George Homer Martin Associates	172	■ Instruments Products Reach, McClinton & Company	214
■ Ballantine Laboratories Lang-Lawrence Advertising	189	■ Electro-Tec Corporation McClellan Associates	48	■ Intercontinental Instruments Incorporated J.S. Lanza & Associates	65
■ Barber-Colman Company— Electrical Components Group Howard H. Monk & Associates	222	■ Electronic Modules Corporation Ray Thompson & Associates	114	■ International Instruments Incorporated Thomas R. Sundheim Incorporated	207
■ Bausch & Lomb Incorporated Wolff Associates Inc.	148	■ Elliott Service Company The Powerad Company	206	■ ITT Jennings Manufacturing Company West, Weir & Bartel Incorporated	187
■ Beckman Instruments Inc.— Helipot Division Hixson & Jorgensen Incorporated	131	■ FMC Corporation— Product Promotion Department Muller, Jordan & Herrick Incorporated	229	■ ITT Semiconductors Division Neals & Hickok Inc.	244
■ Bendix Corporation—Microwave Devices MacManus, John & Adams Inc.	70	■ Fairchild Semiconductor Incorporated Faust & Day Incorporated	33 & 34	■ J F D Electronics Company— Components Division Michel-Cather Incorporated	28
■ Bendix Corporation—Montrose Division MacManus, John & Adams Inc.	36	■ Fluke Manufacturing Company, John Bonfield Associates	15	■ Jerrold Corporation— Jerrold Electronics Division Lescarboua Advertising Incorporated	14
■ Benrus Watch Company—Technical Products Division S & S Creative Services	223	■ Garrett Corporation— Airesearch Manufacturing Division J. Walter Thompson Company	171	■ Johnson Company, E.F. Midland Associates	217
■ Bolt Beranek & Newman Inc. Leland Oliver Company	140 & 141	■ General Aniline & Film Corporation— Photo & Repro Division Hazard Advertising Company Incorporated	68	■ Lambda Electronics Corporation Michel Cather Incorporated	197
■ Borden Chemical Company— Mystik Tape Industrial Division Conahay & Lyon Inc.	185	■ General Electric Company— Capacitor & Components Division George R. Nelson Co.	64	■ Leach Corporation Jay Chiat & Associates	200
■ Bud Radio Incorporated Allied Advertising Agency	202	■ General Electric Company— Lamp Metals & Components Division Dix & Eaton Incorporated	170	■ Litton Industries Incorporated West, Weir & Bartel Incorporated	66
■ Bourns Incorporated Lester Company, The	136	■ General Radio Company Horton, Church & Goff Inc.	2nd cover	■ Litton Industries Incorporated— Winchester Electronics Division West, Weir & Bartel Incorporated	167
■ Bulova Watch Company— Electronics Division Frank Best Co., Inc.	166	■ Granger Associates West Associates	155	■ Louisiana, State of Dept. of Commerce & Industry Bauerlein Incorporated	158
■ Bussmann Mfg. Division of McGraw Edison Company Henderson Advertising Company	151	■ Hamilton Watch Company Beaumont, Heller & Sperling Incorporated	10	■ Machlett Laboratories— Division of Raytheon Company Fuller, Smith & Ross Incorporated	9
■ Cambridge Thermionic Corporation Chirurg & Cairns Inc.	126	■ Hansen Manufacturing Company Keller-Crescent Company	149	■ P.R. Mallory & Company, Manufacturing Div. Aitkin-Kynett Company	230 & 231
■ Cherry Electrical Products Corporation K & A Incorporated	213	■ Heath Company—sub. of Schlumberger Limited Advance Advertising	215	■ Maryland Telecommunications Incorporated Ray E. Finn Advertising	132
■ Cinch Manufacturing Company Stral Advertising Company	240 & 241	■ Hewlett Packard Associates Lennen & Newell Incorporated	123	■ Mepco Incorporated Ray Ellis Advertising Corporation	67
■ Clairex Corporation Michel-Cather Incorporated	190	■ Hewlett Packard— Colorado Springs Division Tallant & Yates Inc.	3rd cover	■ Mico Instrument Company	212
■ Clare & Company, C.P. Reincke, Meyer & Finn Advertising Incorporated	160 & 161	■ Hewlett Packard—Dymec Division Lennen & Newell Incorporated	1	■ Microlab FXR Frank Best & Company, Incorporated	74
■ Clarostat Manufacturing Company Lescarboua Advertising Incorporated	63	■ Hewlett Packard— Frequency & Time Division Lennen & Newell Incorporated	12 & 13	■ Minnesota Department of Business Development White, Herzog & Nee, Incorporated	128
■ Cleveland Institute of Electronics Foote, Cone & Belding Rapp & Collins Division	238	■ Hewlett Packard— Loveland Division Tallant & Yates Inc.	2	■ Monsanto Chemical Company— Inorganic Division Foote, Cone & Belding Inc.	30 & 31
■ Clifton Precision Products Company— Division of Litton Industries Ivey Advertising Inc.	24	■ Honeywell Computer Control Division Franklin P. Folts Co.	43	■ Motorola Semiconductor— Products Incorporated Lane & Bird Advertising Incorporated	107
■ Communications Electronics Incorporated S.G. Stackig Incorporated	196	■ Hull Corporation Michener Company Advertising	203	■ National Cash Register Allen Dorsey & Hatfield Inc.	212
■ Conductron MRC Division Gray & Kilgore Incorporated	194	■ Hysol Corporation Barber & Drullard Incorporated	174		
■ Consolidated Avionics Corporation Stanley Schwartz Company	211	■ I R C Incorporated Gray & Rogers Incorporated	162		
■ Consolidated Electrodynamics— Corporation Sub. of Bell & Howell Hixson & Jorgensen Incorporated	32	■ Image Instruments Incorporated L.K. Frank Company Incorporated	52		



Advertising sales staff

Frank E. LeBeau [212] 971-6464

Advertising sales manager

Wallis Clarke [212] 971-2187

Assistant to sales manager

Donald J. Austerman [212] 971-3139

Promotion Manager

Atlanta, Ga. 30309: Michael H. Miller, 1375

Peachtree St., N.E.

[404] TR 5-0523

Boston, Mass. 02116: William S. Hodgkinson

McGraw-Hill Building, Copley Square

[617] CO 2-1160

Chicago, Ill. 60611: Robert M. Denmead,

J. Bradley MacKimm, Ralph Hanning,

645 North Michigan Avenue,

[312] MO 4-5800

Cleveland, Ohio 44113: William J. Boyle, 55

Public Square, [216] SU 1-7000

Dallas, Texas 75201: Richard P. Poole, 1800

Republic National Bank Tower,

[214] RI 7-9721

Denver, Colo. 80202: Joseph C. Page, David

M. Watson, Tower Bldg., 1700 Broadway,

[303] 255-5484

Detroit, Michigan 48226: Ralph Hanning

856 Penobscot Building

[313] 962-1793

Houston, Texas 77002: Kenneth George,

2270 Humble Bldg., [713] CA 4-8381

Los Angeles, Calif. 90017: Ian C. Hill,

John G. Zisch, 1125 W. 6th St.,

[213] HU 2-5450

Minneapolis, Minn. 55402: J. Bradley

MacKimm, 1104 Northstar Center

[612] 332-7425

New York, N. Y. 10036:

Donald R. Furth [212] 971 3615

James R. Pierce [212] 971-3616

Stanley J. Kail, Jr. [212] 971-3617

500 Fifth Avenue

Philadelphia, Pa. 19103:

Warren H. Gardner, Jeffrey M. Preston,

6 Penn Center Plaza,

[215] LO 8-6161

Pittsburgh, Pa. 15222: Warren H. Gardner,

4 Gateway Center, [412] 391-1314

Portland, Ore. 97204: James T. Hauptli,

218 Mohawk Building, 222 S.W. Morrison

Street, Phone [503] 223-5118

Rochester, N.Y. 14534: William J. Boyle,

9 Greylock Ridge, Pittsford, N.Y.

[716] 586-5040

St. Louis, Mo. 63105: Robert M. Denmead

The Clayton Tower, 7751 Carondelet Ave.

[314] PA 5-7285

San Francisco, Calif. 94111:

James T. Hauptli, 255 California Street,

[415] DO 2-4600

London W1: John W. Patten, Edwin S.

Murphy Jr., 34 Dover Street,

Hyde Park 1451

Milan: Robert M. Saidel

1 via Baracchini Phone: 86-90-656

Frankfurt/Main: Gerd Hinske, Dieter

Rothenbach, Elsa-Brandstroem Str. 2

Phone: 72 01 81

Geneva: Michael R. Zeynel,

1, rue du Temple Phone: 31 95 60

Paris VIII: Denis Jacob, Kenneth Davey,

17 Avenue Matignon Phone: 359 6637

Tokyo: Nobuyuki Sato, 1, Kotohiracho

Shiba, Minato-Ku [502] 0656

Osaka: Ryoji Kobayashi 163, Umegae-cho

Kita-ku [362] 8771

Business department

Wallace C. Carmichael, Manager

[212] 971-3191

Stephen R. Weiss, Production Manager

[212] 971-2044

Thomas M. Egan,

Assistant Production Manager [212] 971-3140

Dorothy Carmesin, Contracts and Billings

[212] 971-2908

Circulation and research

Milton Drake, Manager [212] 971-3405

Isaaca Siegel, Assistant Circulation Manager

[212] 971-6857

David Strassler, Assistant Research Manager

[212] 971-6058

Chloe D. Glover, Research Associate

[212] 971-6057

Electronics buyers' guide

George F. Werner, General Manager

[212] 971-2310

Regina Hera, Directory Manager

[212] 971-2544

Thomas M. Egan, Production Manager

[212] 971-3140

National Semiconductor Corporation	208 & 209
Michel-Cather Incorporated	
North Atlantic Industries Inc.	56
Murray Heyert Associates	
Ohmite Manufacturing Company	147
Fensholt Advertising Agency	
Parker Instruments Corp.	192
William Hill Field Advertising	
Pennsalt Chemicals Corporation	129
Aitkin-Kynett Company Incorporated	
■ Philbrick Researches Incorporated	157
Culver Advertising Incorporated	
Philco Ford Company	69
Hofer, Dieterich & Brown Incorporated	
Pizon Brothers	206
Agence Max Gottschalk	
Polaroid Corporation	237
Doyle, Dane, Bernbach Incorporated	
Precision Paper Tube Company	219
T.W. Blakeslee Advertising	
Q MAX Corporation	214
George Homer Martin Associates	
RCL Electronics Incorporated	192
Morway Advertising Agency	
Radette Company	217
Savell-Keating Advertising	
Radio Corporation of America	6, 47, 4th cover
Al Paul Lefton Company	
Rosemount Engineering Company	154
Colle & McVoy Inc.	
Radiation Incorporated	54 & 55
Basford Incorporated	
Rotron Manufacturing Company	7
Lescarboura Advertising Incorporated	
Sage Electronics Corporation	221
Mathison Advertising Incorporated	
■ Sanders Associates	159
Chirurg & Cairns Incorporated	
Sansha Electric Trading Company, Limited	212
Scientific Data Systems	17
Doyle, Dane, Bernbach Incorporated	
Semtech Corporation	206
Burress Advertising	
Sierra Electronics Division, Philco Ford	232
Hal Lawrence Incorporated	
Sigma Instruments Incorporated	195
Marschalk Company Incorporated	
Speer Carbon Company Division (Air Reduction Company Incorporated)	45
Hazard Advertising Company Incorporated	
Sorensen Operation (Raytheon Company)	11
James Advertising Incorporated	
Spectra-Physics, Incorporated	199
Hal Lawrence Incorporated	
Spectrol Electronics (Carrier Corporation)	205
Jones, Maher Roberts Advertising	
Sperry Rand Corporation	62
Reach, McClinton & Company	
The Sprague Electric Company	5, 8, 16
Harry P. Bridge Company	
■ Stackpole Carbon Company—Electronic Components Division	53
Meek & Thomas, Incorporated	
Steroline Systems Corporation	221
Clinton E. Frank Incorporated	
Stewart Warner Micro Circuits Incorporated	27
Jones, Maher, Roberts Advertising	
Sylvania Electric Products Incorporated (Parts Division)	49
Tatham-Laird & Kudner Incorporated Advertising	

TRG, Incorporated (Division of Control Data Corporation)	125
Culver Advertising Incorporated	
TRW—Capacitors	135
Fuller & Smith & Ross Inc.	
TRW—Equipment Operating	150
Ritchie & Sattler, Incorporated	
Tally Corporation	71
Bonfield Associates Incorporated	
Taylor Corporation	143
Gray & Rogers Incorporated	
■ Tektronix Incorporated	130
Hugh Dwight Advertising Incorporated	
Teledyne Telemetry Company—Division of Teledyne Incorporated	219
S. Michelson Advertising	
Telonic Engineering Company	191
Jansen Associates Incorporated	
Telonic Instruments	51
Jansen Associates Incorporated	
Tempress Research Company, Incorporated	201
Hal Lawrence Incorporated	
Texas Instruments Incorporated	168
Robinson-Gerrard Inc.	
■ Tracor, Incorporated	173
Weekley & Valenti Incorporated	
Transformer Electronics Company	218
Dacey, Wolff & Associates	
Trygon Electronics	188
Solow & Weston Company Incorporated	
Ulano & Company, J.	57
Byrde, Richard & Pound Incorporated	
United Systems Corporation	223
Advertising & Merchandising Incorporated	
■ Vactec, Incorporated	194
Coleman & Associates Advertising	
Vector Electronics Company	211
VanDer Boom, McCarron Incorporated	
Velonex Division of Pulse Engineering Incorporated	29
Hal Lawrence Incorporated	
Volkert Stampings	190
Fred Wittner Company	
Wayne Kerr Corporation	50
Josephson, Cuffari Company	
Westinghouse Semiconductor Division	127
ITSM Division of McCann-Erickson	
Weston Instruments (Archbald Division)	165
Arndt, Preston, Chapin, Lamb & Keen Incorporated	
S.S. White Company (Airbrasive Division)	152
W.L. Towne Company, Incorporated	

Classified Advertising

F.J. Eberle, Business Mgr.

PROFESSIONAL SERVICES 224

EMPLOYMENT OPPORTUNITIES 224-225

EQUIPMENT

(Used or Surplus New)

For Sale

ADVERTISERS INDEX

Columbia Electronics	224
Ideal Club of America, Inc.	224
Radio Research Instrument Co.	224
U.S. Navy, Naval Laboratories of the Potomac	225
U.S. Navy, Naval Research Laboratory	224

■ For more information on complete product line see advertisement in the latest Electronics Buyers' Guide

Learn why

Please send me a FREE copy of "Transistor characteristics related to circuit performance," along with detailed specifications on ITT strip line transistors.

Name Title

Company

Address

City State Zip

ITT's exclusive strip line packaging makes VHF/UHF transistor circuits work better

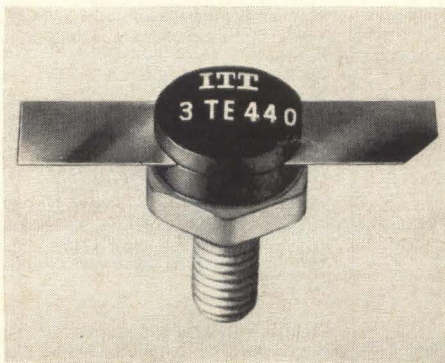

The strip line package reduces or eliminates many of the difficulties that were formerly inevitable when working with high-power VHF-UHF transistors.

Consider these advantages: strip line configuration simplifies final tune-up by virtually eliminating instability; low-inductance package means easier matching to driver stages and broad bandwidth. For 400 MHz application, you may select the 3TE440 (15 watts output) or the 3TE450 (4 watts output).

For full details fill in the coupon above. Or see for yourself — sample quantities are available off the shelf from your ITT distributor or factory representative.

ITT
SEMICONDUCTORS

ITT SEMICONDUCTORS IS A DIVISION OF INTERNATIONAL TELEPHONE AND TELEGRAPH CORPORATION, 3301 ELECTRONICS WAY, WEST PALM BEACH, FLORIDA. FACTORIES IN WEST PALM BEACH, FLORIDA; PALO ALTO, CALIFORNIA; LAWRENCE, MASSACHUSETTS; HARLOW AND FOOTSCRAY, ENGLAND; FREIBURG AND NURENBERG, GERMANY

hp140A—The Scope System that gives you

BETTER PERFORMANCE

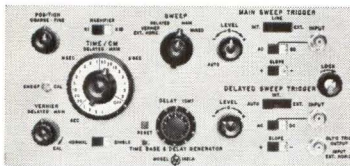
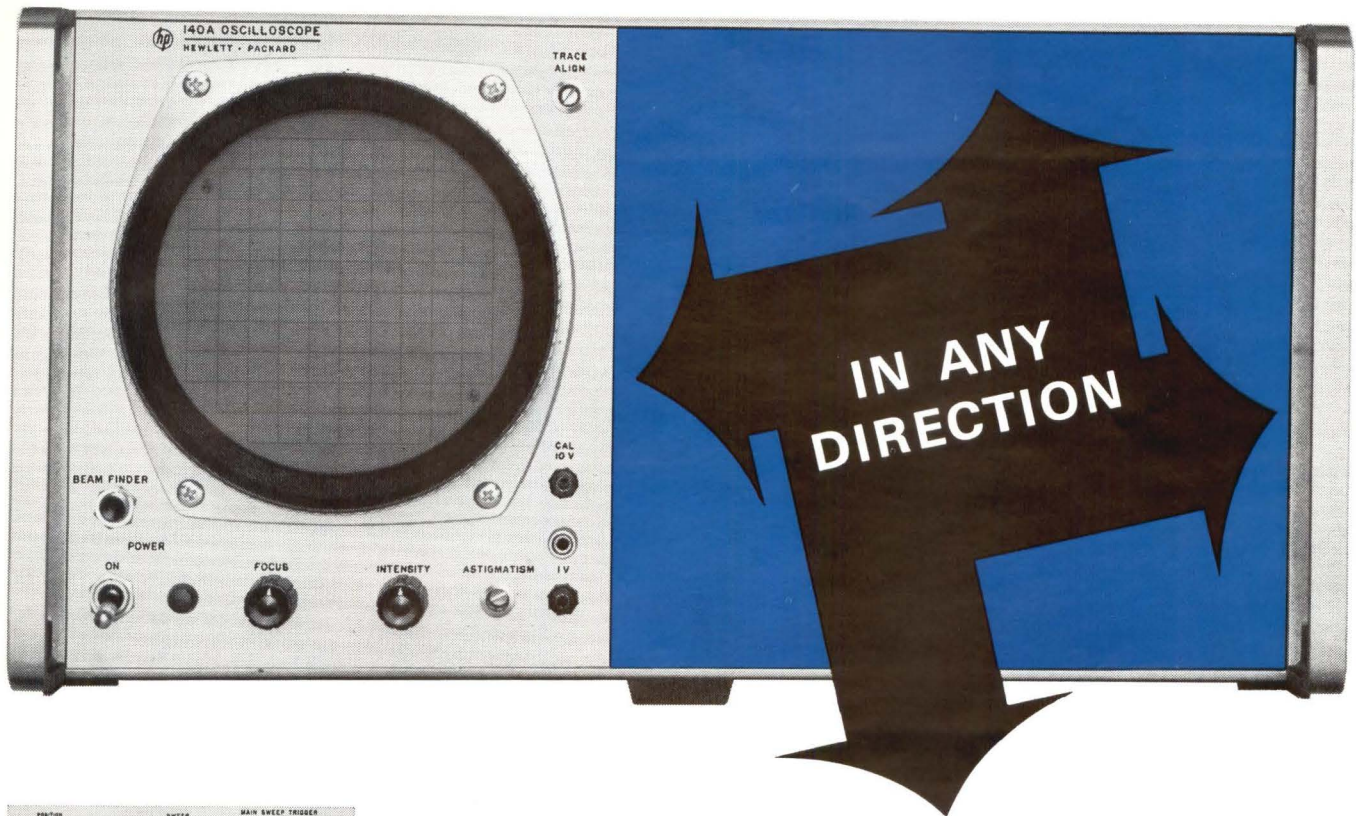

1421A—Time Base and Delay Generator

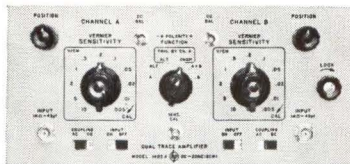

1402A—20 MHz Dual Trace Amplifier

Get 20 MHz bandwidth and delayed sweep readability. With this scope you can choose from 17 plug-ins that cover the entire measurement spectrum. If you need wideband performance, for example, you can use the dual-trace 1402A vertical amplifier and get DC to 20 MHz at 5 mv/cm, algebraic addition, built-in delay line for viewing fast-rise pulses, full 6 cm deflection and a wide dynamic range.

For easy readability of complex waveforms and accurate time interval measurements, Model 1421A time base provides extreme magnification and sweep speeds from 1 sec/cm to 20 ns/cm. It also offers the additional advantage of exclusive hp mixed sweep. This feature combines display of the first portion of a trace at normal sweep speeds and simultaneously expands the trailing portion of the trace at faster delayed sweep speeds to allow step-by-step magnified examination.

An alternate mainframe (141A) provides equal versatility plus the advantages of variable persistence and storage. Price of the wideband system with 140A mainframe, 1402A vertical plug-in and 1421A horizontal plug-in is \$1795. Price with the 141A mainframe is \$2475.

Ask your hp Sales Engineer for brochure (data sheet 140A) with specs on the 140A wideband system as well as 140A high-sensitivity, TDR or 12.4 GHz sampling systems. You'll find they give more and better measurements in less time. Hewlett Packard, Palo Alto, California, 94304. In Europe: 54 Route des Acacias. Geneva.

106A



hp 140A: PERFORMANCE IN ANY DIRECTION
20 MHz Wideband • High-Sensitivity, no drift
• 150 ps TDR • 12.4 GHz Sampling
• Variable Persistence and Storage

HEWLETT  **PACKARD**
An extra measure of performance



RCA Hometaxial-Base Transistors...

a family of
low-cost, reliable
silicon power transistors
offering you freedom
from the problems
of second breakdown

For more information on Hometaxial-Base transistors, see your local RCA representative, or write: Commercial Engineering, RCA Electronic Components and Devices, Harrison, N.J.

ALSO AVAILABLE THROUGH YOUR RCA DISTRIBUTOR



The Most Trusted Name in Electronics

