

electronics®

THIN-FILM LOG I-F

*Inductors are no
problem, p 46*

"VOLTMETER" DOESN'T MOVE

*Uses saturable
reactor and neon, p 50*

TACTICAL DISPLAY GOES TO SEA

*Inside our floating
war rooms, p 20*

NEW cold-cathodes under study show blue circles on mirror surface as a result of interference effects, p 39

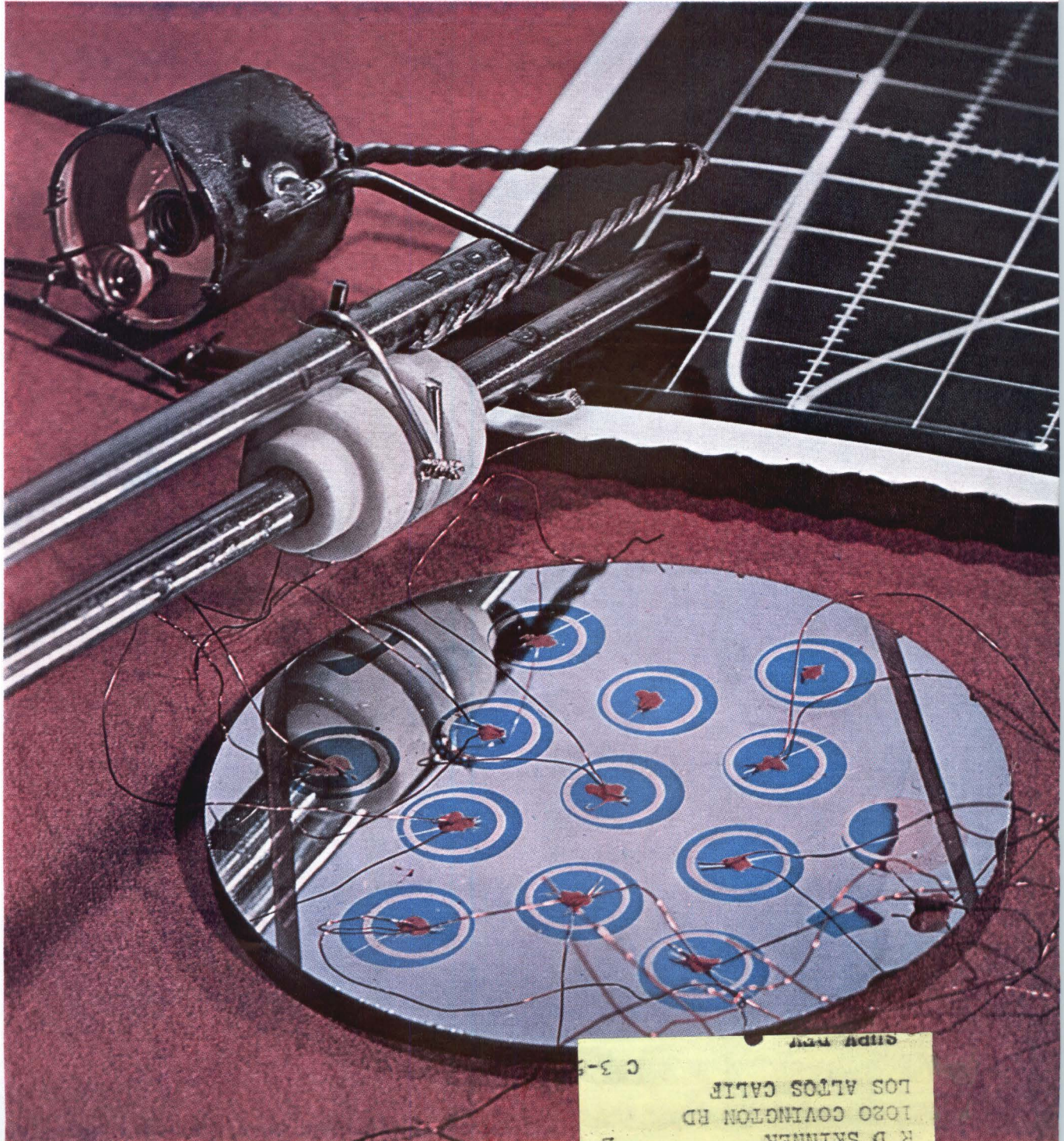

SLIP REV
C 3-9
R D SKINNER
1020 GOVINGTON RD
LOS ALTOS CALIF



AUTOMATIC RECORDING of FREQUENCY RESPONSE

Full-4 inch
recording width
(40-db)
Plot shown actual size

Frequency response of 8" loudspeaker mounted in 1 cu.-ft. enclosure measured in small anechoic chamber.

4 5 6 7 8 9 100 2 3 4
FREQUENCY

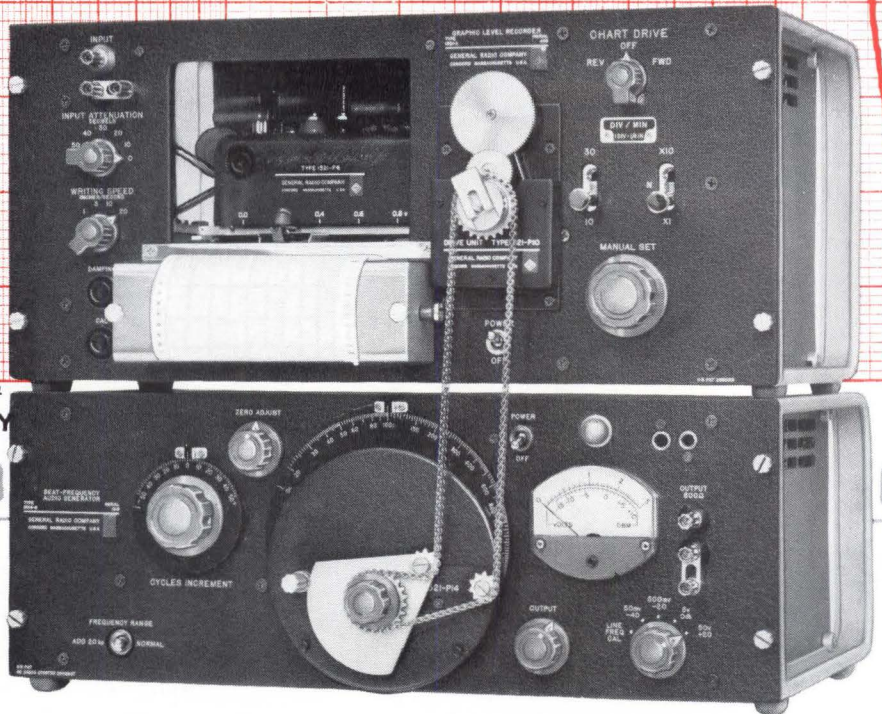

... Complete System
only \$1885

Here are two instruments that work together to provide a permanent and accurate record of frequency response on a truly logarithmic scale. With this system you can conveniently study and analyze the performance of filters, networks, amplifiers, equalizers, loudspeakers, microphones, and transducers of all types.

The recorder, in its own right, finds extensive use in any electronics laboratory. It has an inherent versatility that permits its use as a general-purpose dc recorder, or for recording the output levels of a variety of other instruments including spectrum analyzers.

Frequency Range: Generator, 20c to 20 kc on logarithmic scale, 20 kc to 40 kc. Recorder, traces rms level 20c to 200 kc.

Generator Output: Flat within ± 0.25 db from 20c to 20 kc. Output is adjustable from 5 mv to 50v open-circuit. Harmonic distortion is less than 0.25% from 100c to 10 kc, 0.5% below 100c, 1% above 10 kc.

Recorder Sensitivity: 1 mv, maximum (corresponds to 0 db). Can be varied from 1 mv to 1v in 10-db steps with input attenuator.

Recorder Range: 40-db full scale, with plug-in potentiometer supplied; 20-db and 80-db pots also available.

Recorder Accuracy: Static accuracy better than 0.4% of full scale. Fast servo system with low overshoot provides excellent dynamic accuracy.

Pen Writing Speed: 20 in/sec maximum with 40-db Pot (200 db/sec) with less than 1-db overshoot. Slower speeds (1, 3, or 10 in/sec) selected by panel switch to provide mechanical filtering of rapidly fluctuating levels.

Paper Speeds: 2.5, 7.5, 25, and 75 in/min. Optional slow-speed motor available for speeds from 2.5 to 75 in/hr.

Charts: Four different type charts available, each 5 inches wide with 8 major divisions. Each frequency decade on the logarithmic scale is equal in length to the 30-db calibration on the vertical scale, as specified by EIA Standard SE-103.

Write for Complete Information

Type 1304-B Beat-Frequency Audio Generator.....	\$795
Type 1521-A Graphic Level Recorder (with 40-db potentiometer).....	\$995
Type 1521-P10 Drive Unit.....	\$ 72
Type 1521-P14 Link Unit.....	\$ 23
Complete System	\$1885

GENERAL RADIO COMPANY
WEST CONCORD, MASSACHUSETTS

In EUROPE
General Radio
Overseas
Zurich, Switzerland

NEW YORK, N. Y., 964-2722
Ridgefield, N. J., 943-3140
CHICAGO
(Oak Park) 848-9400
PHILADELPHIA, 424-7419
Abington, 887-8486
WASHINGTON, D. C.
(Rockville, Md.) 946-1600
SYRACUSE
454-9323
DALLAS
FL 7-4031
SAN FRANCISCO
(Los Altos) 948-8233
LOS ANGELES
469-6201
ORLANDO, FLA.
425-4671

IN CANADA
(Toronto) 247-2171

CIRCLE 900 ON READER SERVICE CARD

electronics

A McGraw-Hill Weekly 75 Cents



W. W. MacDONALD, Editor

J. M. CARROLL, Managing Editor

SENIOR EDITORS

Samuel Weber, George W. Sideris

SENIOR ASSOCIATE EDITORS

Michael F. Wolff, John F. Mason

ASSOCIATE EDITORS

Michael F. Tomaino, William P. O'Brien, Sy Vogel, George J. Flynn, Laurence D. Shergalis, George V. Novotny, Leon H. Dulberger, Alexander A. McKenzie

ASSISTANT EDITORS

Stanley Froud, Stephen B. Gray, Roy J. Bruun, Barry A. Briskman, Dan Smith, Joel A. Strasser

REGIONAL EDITORS

Harold C. Hood (Pacific Coast, Los Angeles), Thomas Maguire (New England, Boston), Cletus M. Wiley (Midwest, Chicago)

ART DIRECTOR

Howard R. Berry

ASSISTANT ART DIRECTOR

John C. Wright, Jr

EDITORIAL ASSISTANTS

Lorraine Rossi, Virginia T. Bastian, Lynn Emery, Ann Mella, Lorraine Werner, Alice M. O'Brien, Sharon Parks, Patricia Mitchell, Claire Benell

FOREIGN NEWS BUREAUDIRECTOR, John Wilhelm;
Alyne Elias, Charles Obertance

LONDON—John Shinn, Derek Barlow, Nicholas Landon

BONN—Bruce Bendow,
Richard Mikton, Silke McQueen

BRUSSELS—Peter Forbath

PARIS—Robert Farrell,
Arthur Erikson

MILAN—Marc A. Messina

MEXICO CITY—Wesley Perry, Jr

RIO DE JANEIRO—Leslie Warren

MOSCOW—Stewart Ramsey

TOKYO—Richard Halloran,
Charles Cohen, John Yamaguchi**CIRCULATION MANAGER**

Hugh J. Quinn

W. W. GAREY, Publisher

SOME LABORATORY apparatus used in recent cold-cathode studies. More than a dozen cold cathodes have been deposited on the mirror surface in the foreground. At the left is a jig used in cold cathode deposition. Waveform is a cold-cathode characteristic curve. *One application: r-f modulation of light beams.* See p 39

COVER

FREQUENCY-CONTROL Advances Pushed by Army. Army still isn't satisfied with crystals for single-sideband gear, and wants cheaper, more reliable clocks. *One of newsbreaks at last week's symposium was that thallium-beam standards may be more accurate than cesium-beam ones*

16

AIR-SEA-SUB DISPLAY Plots Naval Targets. Tactical Navigational Display System is slaved to radar and sonar to show enemy movements. *A scaled-down version of an air-defense display, it is going aboard aircraft carriers*

20

PRINTED-CIRCUIT FIGHT. Technograph loses round 1 in the huge Eisler patents court case. Federal judge rules that patent claims are invalid. *This case affects scores of companies in the electronics industry*

24

DEFENSE SATELLITE NET Is Set for Contracts. Awards next month will launch \$1-billion project. *Unlike civilian communications satellites, the military ones will have few channels, use mobile ground stations*

26

COLOR-TV CAMERA Size Pared. Japanese developing system that needs only two image orthicons. *One tube is for color, the other is luminance pickup*

28

VARACTOR Cutoff is 800 Gc. Gallium-arsenide diode electrically formed in waveguide raises frequency limit some 300 Gc. *Developer expects it to extend range of parametric devices into millimeter region*

31

ARE HOT CATHODES ON THE WAY OUT? Nonthermionic emission mechanisms under study use photoelectric, field emission, secondary emission and plasma effects. They promise to provide high current density, low power consumption, low beam noise and instant starting. *A few are already in use for special applications such as high-speed x-ray photography.*

By W. M. Feist and G. Wade, Raytheon 39

NEW THIN-FILM LOG I-F: Inductors Are No Problem. Inductors required in logarithmic i-f amplifiers of tuned-stage design are not compatible with thin film fabrication. This circuit uses untuned R-C coupled amplifiers, gives a 20 to 120-Mc bandwidth at 10-db gain. *Use of high-performance vhf chip transistors makes it possible.*

By R. Leslie and T. Townsend, AIL Division, Cutler-Hammer 46

Published weekly, with Electronics Buyers' Guide as part of the subscription, by McGraw-Hill Publishing Company, Inc. Founder: James H. McGraw (1860-1948).

Title ® registered U.S. Patent Office; © copyright 1963 by McGraw-Hill Publishing Co., Inc. All rights reserved, including the right to reproduce the contents of this publication, in whole or in part.

Executive, editorial, circulation and advertising offices: McGraw-Hill Building, 330 West 42nd Street, New York 36, N. Y. Telephone Longacre 4-3000. Teletype TWX N.Y. 212-640-4646. Cable McGrawhill, N. Y. PRINTED IN ALBANY, N. Y.; second class postage paid at Albany, N. Y.

OFFICERS OF THE PUBLICATIONS DIVISION: Shelton Fisher, President; Vice Presidents: Joseph H. Allen, Operations; John R. Callahan, Editorial; Ervin E. DeGraff, Circulation; Donald C. McGraw, Jr., Advertising Sales; Angelo R. Venezian, Marketing.

OFFICERS OF THE CORPORATION: Donald C. McGraw, President; Hugh J. Kelly, Harry L. Waddell, L. Keith Goodrich, Executive Vice Presidents; John L. McGraw, Treasurer; John J. Cooke, Vice President and Secretary.

Subscriptions are solicited only from those actively engaged in the field of the publication. Position and company connection must be indicated on orders. Subscription rates: United States and Possessions, \$6.00 one year, \$9.00 two years, \$12.00 three years. Canada: \$10.00 one year. All other countries \$20.00 one year. Single copies, United States and Possessions and Canada 75¢. Single copies all other countries \$1.50.

THE PUBLISHER, UPON WRITTEN REQUEST FROM ANY SUBSCRIBER TO OUR NEW YORK OFFICE AGREES TO REFUND THAT PART OF THE SUBSCRIPTION PRICE APPLYING TO COPIES NOT YET MAILED.

Subscribers: Please send change of address notices, subscription orders or complaints to Fulfillment Manager, Electronics, at the address below. Change of address notices should provide old as well as new address, including postal zone number if any. If possible, attach address label from recent issue. Allow one month for change to become effective.

Postmaster: Please send Form 3579 to Fulfillment Manager, Electronics, P. O. Box 430, Hightstown, New Jersey.



Audited Paid Circulation

CONTENTS continued

VOLTAGE MONITOR Needs Only Two Saturable Cores. This "voltmeter" needs no moving coil. A power supply being monitored is compared with a reference and the difference voltage feeds control windings of saturable cores. *When cores saturate, a neon lamp lights.*
By M. C. Herzog and D. C. Colbert, Electronic Communications 50

TUNNEL DIODES: How to Make Them Even More Useful. Here is a novel contribution to tunnel-diode circuit design. Four diodes can be combined to produce a characteristic curve with three positive-resistance regions separated by negative-resistance regions. *It makes a good tristable circuit or bipolar pulse generator.*
By L. L. Williams and D. J. Hamilton, Univ. of Arizona 52

DEPARTMENTS

Crosstalk. *Tunnel Diodes Revisited* 3

Comment. *Metric System. Dichotomy* 4

Electronics Newsletter. *Superconducting Magnets Reach the Magic Number: 100,000 Gauss* 7

Washington This Week. *This Summer, "Report Cards" for Military Contractors* 12

Meetings Ahead. *Aerospace Electrical/Electronic Conference* 36

Research and Development. *Computer Translates Chinese into English* 56

Components and Materials. *Microcircuits are Busting Out in Britain* 60

Production Techniques. *Pilot Plant Mass Produces Thin Films* 64

New Products. *Automate With This Versatile Counter* 70

Literature of the Week 80

People and Plants. *Raytheon Promotes Three Executives* 82

Index to Advertisers 90

Tunnel Diodes Revisited

WE'VE ALL HEARD the story of the child prodigy who, after a brilliant pre-adolescent academic career in which he reputedly performs unheard of mental feats, carries the awed expectations of parents and friends into the waiting world. Then he fades into obscurity, to be discovered by an enterprising cub reporter forty years later performing some dreary routine bookkeeping task.

That could have been the story of the tunnel diode. But the career of Dr. Esaki's brainchild appears headed for a much happier ending.

When the tunnel diode first made its appearance in the literature five years ago, it was hailed as the answer to a circuit designer's prayer. With one simple device, an engineer could achieve oscillation, amplification, conversion, switching and even combine some of these functions simultaneously. In addition, the device offered high-speed, high-frequency operation, low power consumption, resistance to nuclear radiation and temperature, small size, and light weight! Small wonder that the drums began to beat for the tunnel diode as the replacement for the transistor and the panacea for all circuit problems.

But then reality broke through and disillusionment appeared. Circuit designers were just beginning to feel comfortable with the low-impedance design quirks of the transistor. Now they were expected to accept with equanimity a two-terminal device with no isolation between input and output, coupled with the unfamiliar concept of negative resistance. On top of this, reports began to filter in concerning deterioration of tunnel diode properties on the shelf, of instability of diode characteristics, lack of uniformity from diode to diode. Gradually enthusiasm waned.

Although the manufacturing problems were solved rather quickly, interest in the tunnel diode was considerably diminished in 1961. But over the last two years, we couldn't help noticing that the td has been making a quiet but effec-

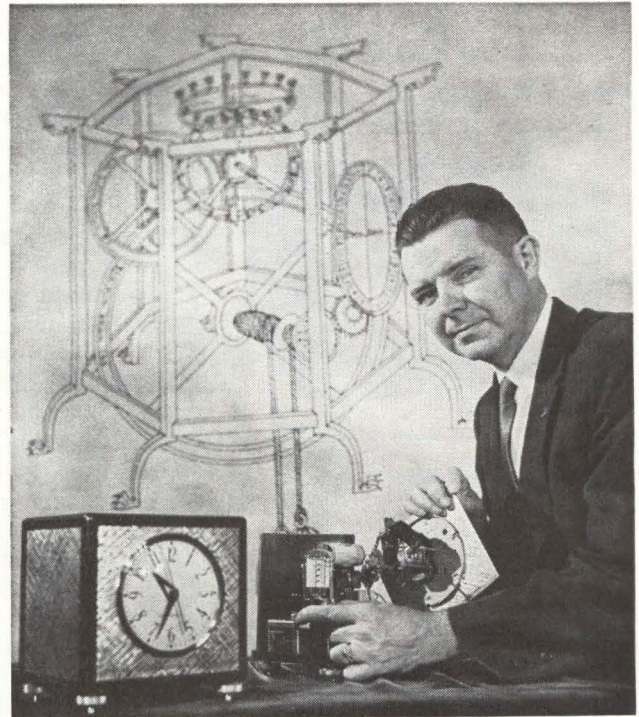

EARLY APPLICATION for tunnel diode was in GE's battery-operated chronometer, shown in foreground. In the background is a 1365 clock

tive comeback and, without the hullabaloo accompanying its debut, is taking its rightful place in the pantheon of semiconductor devices.

We thought that this would be an appropriate time to reevaluate the tunnel diode as a design component. We asked two experts, Eric Gottlieb and John Giorgis, of GE's Semiconductor Products department, to bring our readers up to date on the latest applications and design techniques using this versatile device. The result is a comprehensive four-part series beginning in next week's issue. It may well be the definitive work on tunnel-diode circuit design.

You'll find that the prodigy can be made to live up to its childhood potentialities, provided, as in all such cases, the talent is nurtured and developed carefully, with allowances made for personality quirks.

**now
available
for
immediate
delivery:**

**JERROLD
RF SWEEP
EQUIPMENT
...the industry's
finest!**



**Model 900B
Super Sweep Generator**

Wide plus narrow band in one versatile instrument. Handles all IF, VHF, UHF sweep requirements. Sweep widths from 10kc to 400mc. Frequency range from 500kc to 1,200mc. Built-in crystal-controlled harmonic markers, dc or ac scope preamplifier, precision attenuator. **\$1,980.00**



**Model LA-5100
rf Log Amplifier**

Accurate within ± 1 db over 80db dynamic range. Frequency range 500kc to 100mc. Lets you make exact measurements of attenuation in networks, filters, amplifiers with dynamic ranges down to 85 db. Total rf response displayed in precise log ratio on standard dc-coupled scope. **\$795.00**

Model 900A Wide-Band Sweeper

Sweep widths from 100kc to 400mc. Frequency range from 500kc to 1,200mc. **\$1,260.00**

Model 707 Ultra-Flat Sweeper

Flatness of ± 0.05 db in highest single octave. Plug-in oscillator heads. **\$840.00**

All for immediate delivery. Prices f.o.b. Philadelphia. Write for complete technical data on these and other Jerrold rf test instruments.



Industrial Products
Division,
Philadelphia 32, Pa.



A subsidiary of THE JERROLD CORPORATION

COMMENT

Metric System

In spite of having spent the first 27 years of my life in a country where the metric system is enforced by law, I must admit that I am strongly in favor of this strange way of expressing physical measurements.

The pulse that triggers this letter was the *Newsletter* item about underwater laser tests on p 7 of your April 19 issue, where both meters and feet are used separately and together.

May I suggest a method that might ease the inevitable conversion to the metric system in this country. The various measurements mentioned in the article could have been shown as follows: "Underwater tests show laser ranges up to 1,000 ft (305 meters) . . . about 150 feet (46 meters) are possible . . . two five-inch (12.5-cm) diameter . . . estimated at 150 ft (46 meters) . . . be about 1,000 feet (305 meters) . . ."

Then after a few years of this, you would reverse the terms like this: "about 45 meters (148 feet) are . . . two 12.5-cm (5-inch) diameter . . ." A few more years of this and the metric system could stand alone on its own 60.69 cm (two feet).

FINN POULSEN
Arlington Heights, Illinois

P.S. In my eagerness to express my views on the merit of the metric system, I forgot to tell you that I enjoy the range of articles you have in the magazine, from decimal-to-binary rotary switches and simple transistor testers to space guidance and telemetry systems. All in all, A-OK.

Dichotomy

Congratulations on your editorial highlighting the dichotomy existing at the professional level in the field of electronics. However, we feel that you have incorrectly named the two professions.

Engineering is a profession with many branches, and the term of *engineer* in the electronics field should be applied to those whose

work is analogous to that in other fields of engineering. It is true that an engineer is an innovator; but this does not place him necessarily in the laboratory. Rather, he is the man who takes scientific knowledge, which may be the result of the research of other men, and applies it to produce a given result. This is consistent with the old definition which sees an engineer "using men, money and materials to advance the welfare of mankind."

On the other hand, the man who applies himself to research, with the desire "to find out why" rather than "to achieve a result," is a scientist, and in the case of electronics, probably a physicist.

To sum up, our contention is that the man doing research into fundamental principles is a scientist; the man reducing the results of such research to practical form is an engineer. It is obvious that both these roles are necessary and worthwhile. Further, they are complementary, and at times overlap. A publication such as yours is valuable because it keeps both these groups informed of matters of common interest.

PETER H. GRIFFIN
ERIC G. WARREN
DANIEL B. SOOTHILL

Department of Civil Aviation
Waverton, N.S.W.
Australia

Radio-Interference Control

An unfortunate transposition took place in the printing of my article, Radio-Interference Control—What it Means to Systems Design (p 56, April 26).

The text is broken at line 6 of column 2, p 58, and picks up at line 10 of column 3, p 58. The correct text should read ". . . during their discussions, the rfi engineer reviews and evaluates the various approaches . . ."

The transposed section, 44 lines long, belongs after line 15 of column 1, p 59. The correct text should read ". . . $\Delta f = 3$ db bandwidth at f_o ; $f_o =$ frequency to which the preselector is tuned . . ." and ending with ". . . the susceptibility threshold is -97 dbm, which is more than adequate."

M. REVZIN
Loral Electronics Corp.
Bronx, New York

Lambda announces 3 new LE models

Environment-
Engineered at
competitive prices

LE 106 0-18VDC 15 AMP • LE 107 0-18VDC 22 AMP • LE 110 0-9VDC 20 AMP

Note these quality design features

CONVECTION COOLED

No blowers or filters;
maintenance free.

WIDE INPUT RANGE

Wide input voltage
and frequency range
—105-135 VAC,
45-66 CPS and
320-480 CPS in two
bands selected
by switch.

COMPLETELY PROTECTED

against—short circuit and
electrical overload; input line
voltage transients; excessive
ambient temperatures. No
voltage spikes due to "turn-on,
turn-off" or power failure.

9 models available

CONSTANT VOLTAGE CONSTANT CURRENT

by automatic switchover.

REMOTELY PROGRAMMABLE AND CONTINUOUSLY VARIABLE

Voltage continuously variable over entire range.
Programmable over voltage and current range.

OTHER FEATURES

- All solid state.
- Adjustable automatic current limiting.
- 0°C to + 50°C ambient.
- Grey ripple finish.
- Ruggedized voltmeters and ammeters per MIL-M-10304B on metered models.

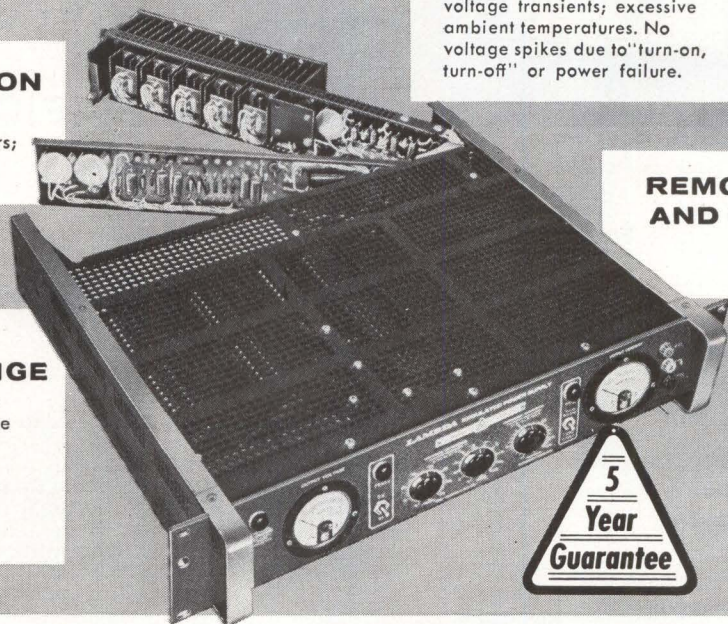

LE SERIES CONDENSED DATA

DC OUTPUT (VOLTAGE REGULATED FOR LINE AND LOAD)⁽¹⁾

Model	Voltage Range	Current Range	Price ⁽²⁾
LE101	0-36 VDC	0- 5 Amp	\$420
LE102	0-36 VDC	0-10 Amp	525
LE103	0-36 VDC	0-15 Amp	595
LE104	0-36 VDC	0-25 Amp	775
LE105	0-18 VDC	0- 8 Amp	425
LE106	0-18 VDC	0-15 Amp	590
LE107	0-18 VDC	0-22 Amp	695
LE109	0- 9 VDC	0-10 Amp	430
LE110	0- 9 VDC	0-20 Amp	675

⁽¹⁾ Current rating applies over entire voltage range.

⁽²⁾ Prices are for nonmetered models. For models with ruggedized MIL meters add suffix "M" to model number and add \$40 to the non-metered price. For metered models and front panel control add suffix "FM" and add \$50 to the nonmetered price.

REGULATED VOLTAGE:

Regulation

(line and load) Less than .05 per cent or 8 millivolts (whichever is greater). For input variations from 105-135 VAC and for load variations from 0 to full load.

Remote Programming 50 ohms/volt constant over entire voltage range.

Ripple and Noise Less than 0.5 millivolt rms.

Temperature Coefficient Less than 0.015%/°C.

AC INPUT: 105-135 VAC; 45-66 CPS and 320-480 CPS in two bands selected by switch.

PHYSICAL DATA:

Mounting Standard 19" rack mounting.

Size LE 101, LE 105, LE 109 3½" H x 19" W x 16" D
LE 102, LE 106, LE 110 5¼" H x 19" W x 16" D
LE 103, LE 107 7" H x 19" W x 16½" D
LE 104 10½" H x 19" W x 16½" D

SEND FOR LAMBDA CATALOG.



LAMBDA ELECTRONICS CORP.

515 BROAD HOLLOW ROAD • MELVILLE, L. I., NEW YORK • 516 MYRTLE 4-4200

SALES OFFICES AND REPRESENTATIVES CONVENIENTLY LOCATED IN MAJOR CITIES

CIRCLE 5 ON READER SERVICE CARD

SIMPLIFY communications maintenance

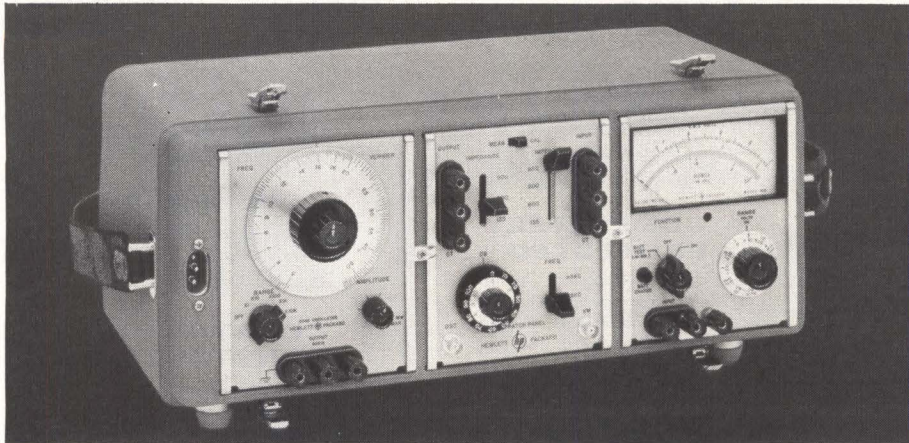

**NEW
portable
test set
measures
gain,
attenuation,
frequency
response**

SPECIFICATIONS

The new **hp** 3550A Portable Test Set, designed specifically for transmission system testing, is especially useful for alignment and maintenance of multichannel communication systems. It incorporates a 5 cps to 560 kc oscillator with fully floating output, a 1 mv to 300 v 5 cps to 2 mc voltmeter, and attenuator and impedance matching networks to individually match the oscillator and voltmeter to 135, 600 and 900 ohm lines.

The solid state instruments are housed in a compact case with a splash-proof cover, and both the oscillator and voltmeter operate from internal rechargeable batteries or from an ac line. The three instruments may be used separately in or out of the case.

The oscillator provides flat frequency response and excellent amplitude and frequency stability. The highly accurate voltmeter provides a db scale for easy measurement —72 to +52 dbm. The attenuator and impedance matching unit includes calibrate features to eliminate insertion loss. Oscillator and voltmeter batteries recharge during ac operation.

Check the specifications for the remarkable versatility and convenience of this test set, then contact your **hp** representative or call direct for a demonstration on your bench or in the field.

Frequency Range:
Dial Accuracy:
Frequency Response:
Output Impedance:
Output:
Distortion:
Hum and Noise:
Temperature Range:

OSCILLATOR (**hp** H07-204B)

5 cps to 560 kc, 5 ranges
±3%
±3% into rated load
600 ohms
10 mw (2.5 v rms) into 600 ohms, 5 v rms open circuit, completely isolated
Less than 1%
Less than 0.05%
—20° to +50° C

Range:
Frequency Range:
Accuracy:

VOLTMETER (**hp** 403B)

0.001 to 300 v rms full scale; —72 to +52 dbm
5 cps to 2 mc
0° C to 50° C, within ± 2% of full scale from 10 cps to 1 mc, within ± 5% of full scale from 5 to 10 cps and 1 to 2 mc (on 300 v range, accuracy is ± 10% from 1 to 2 mc; AC-21A 10:1 Divider Probe allows measurements to 300 v in the 1 to 2 mc range with an accuracy of ± 5%); 0° C to — 20° C, ± 8% of full scale from 5 cps to 2 mc

Nominal Input Impedance:

2 megohms, shunted by approximately 40 pf on 0.001 v to 0.03 v ranges, 20 pf on 0.1 v to 3 v ranges, 15 pf on 10 to 300 v ranges

DC Isolation:
Noise:

Signal ground may be ±500 v dc from external case
Less than 4% of full scale on 1 mv range, 3% on other ranges

Attenuation:
Accuracy:

ATTENUATOR/PATCH PANEL

110 db in 1 db steps
10 db section, error less than ±0.125 db at any step, dc to 100 kc; less than ±0.25 db, 100 kc to 1 mc.
100 db section, error less than ±0.25 db at any step up to 70 db, less than ±0.5 db above 70 db, from dc to 100 kc; less than ±0.5 db up to 70 db, less than ±0.75 db above 70 db, 100 kc to 1 mc

Impedance:
Input and Output:

600 ohms
50 cps to 560 kc; balance better than 40 db; frequency response ±0.5 db, 50 cps to 560 kc; impedance, 135, 600, 900 ohms center tapped. Input includes 10K bridging impedance; insertion loss, less than 0.75 db at 1 kc; maximum level +10 dbm (2.5 v into 600 ohms)

GENERAL

Power: Voltmeter and oscillator each use a power supply of 4 rechargeable batteries (furnished, 40 hr. operation per recharge [20 hours at —20° C], up to 500 recharging cycles). Automatic recharging during ac operation

Dimensions:
Price:

8¾" high, 19¼" wide, 13¼" deep. Weight 30½ lbs.
\$990.00

Data subject to change without notice. Price f.o.b. factory.



HEWLETT-PACKARD COMPANY

1501 Page Mill Road, Palo Alto, California, Area Code 415, DA 6-7000
Sales and service representatives in all principal areas; Europe, Hewlett-Packard S. A., 54-54bis Route des Acacias, Geneva; Canada, Hewlett-Packard (Canada) Ltd., 8270 Mayrand Street, Montreal

Superconductor Hits 101,000 Gauss

SUPERCONDUCTING magnet has created fields up to 101,000 gauss in laboratory experiments, GE says. This is the strongest field yet reported for a superconductor, although earlier advances in materials and techniques (p 18, March 1) indicated that the 100,000-gauss barrier was likely to be broken before the end of the year. Previously, 75,000 gauss, achieved by Magnion (p 8, May 10), was the strongest field reported.

GE's record-breaking solenoid was made from 600 feet of 1/40-inch-diameter niobium-tin conductor wound on a 3/4-inch diameter tube. The coil is approximately 2 inches long and 2 inches in diameter. Currents as high as 266 amps were applied and the temperature was maintained at 1.8 K. Six ordinary automobile storage batteries were used as the power source. GE says it has devised fabricating techniques that circumvent niobium-tin's major disadvantage, extreme brittleness. The material has a critical field of 190,000 gauss.

Poland Constructs Radio Factory in Cuba

BELGRADE—According to the Warsaw daily "Tribuna Ludu", Poland has completed construction of a \$8.5-million radio-receiver factory at Rancho Bayoros, near Havana, Cuba. All installations are of Polish manufacture, the newspaper said. The receivers to be produced will be a counterpart of the Polish "Figaro" sets. The new plant is one of 14 different factories Poland has agreed to build in Cuba.

Electron Beam Checks Microelectronic Structures

APPLICATIONS of optoelectronic and molecular techniques to microelectronic structures highlighted a

closed meeting last month sponsored by DOD's Advisory Group on Electron Devices at Research Triangle Institute, Durham, N. C. Topics included: a low-level silicon chopper activated by photon emission from gallium arsenide; the use of phonon coupling in silicon structures, including a thermal flip-flop structure; a scanning electron-beam machine used as a nondestructive diagnostic instrument for microelectronic structures. In the latter, potential gradients associated with junctions and with failure modes are clearly indicated in the image tube.

Long-Run Experiment Shows Cryotron Utility

CAMBRIDGE, MASS.—A cryotron thin-film memory-logic circuit in continuous cycling at A. D. Little, Inc. here had gone through 11 days of persistent-current operation early this week. It is believed to be the first time a cryotron device has been operated in a closed-cycle refrigerator.

A total of 140 cryotrons are used in the seven-level memory-logic de-

Balancing Act

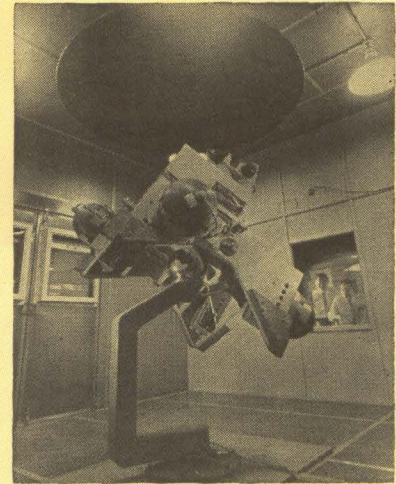

SATELLITE simulator at Westinghouse Air Arm simulates movements of orbiting satellite. It's balanced on 12-inch, air-floated ball bearing. Attitude is changed by small air jets, warm aluminum dish overhead simulates earth

vice to demonstrate typical computer circuit functions that can be performed by cryotrons: clock, pulse shaper, double-layer binary counter, tree switch, and 32-bit non-destructive memory (8 words, 4 bits per word). Information orig-

Foot Soldier Needs Better Power Sources

ARMY ISN'T saying anything officially, but it is dissatisfied that power sources used by individual soldiers have not kept pace with other advances in electronics, that there have been orders-of-magnitude improvement in such areas as microminiaturization but only a three-to-one improvement in power sources for field use.

Roughly 75 percent of field failures of communications gear is blamed on power supplies. Army wants an efficient source of 150-w power, the average requirement for hand-held electronics.

Here's what the Army says is wrong with present devices:

Thermionic power sources are hot and inefficient; fuel cells are not yet reliable or efficient in any practical size; nuclear techniques require extensive shielding and reach prohibitive weights rapidly; cadmium-class batteries aren't efficient enough and it is often two to three seconds before power is available.

In a recent radio design, the Army went back to its old standby, the carbon-zinc battery

Instant X-Ray

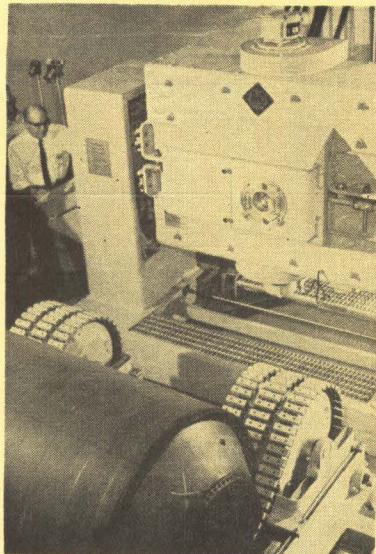

BETATRON automated x-ray system made for Redstone Arsenal by Allis-Chalmers indicates flaws on roll-chart recording instead of film. Photosensitive system detects flaws in rocket (foreground) as difference in light output of sodium-iodide crystals

inally stored has been read billions of times. Only one word of the original has been rewritten, demonstrating the nondestructive character of the memory. The device does not require an outside driver. Speed of circuit can be varied by varying oscillator speed from 50 Kc to 200 Kc. ADL researchers say speed could be pushed up to 500 Kc.

Radio Inside Eye May Probe Glaucoma

PASSIVE MINIATURE radio transmitter placed within the eye of an animal or human being may provide a revolutionary method for studying glaucoma, suggests Prof. R. Stuart Mackay, of the University of California at Berkeley. The device could indicate over the long run what psychological and physical effects contribute to a buildup of pressure within the eye, he said. Glaucoma depends on such increases in pressure.

Mackay said experiments carried out at 60 Mc by one of his students, Arthur Chen, indicate the feasibility of this method. Chen employed

the two perpendicular coil method and, while sweeping the transmitter frequency, noted the instant of maximum response in the receiver circuit.

Russian Describes Soviet Plasma Work

DETAILS of several Soviet plasma oscillators and amplifiers were given ELECTRONICS last week by Professor Z. S. Chernov of Moscow's Academy of Science, an exchange fellow at Brooklyn Polytechnic Institute. He reported gains of 40 to 50 db with 3-cm waves amplified over a 15-cm path with a 5 to 7-cm discharge, and gains of 20 db for 8-mm waves. Soviet plasma amplifiers have shown an output of 100 to 200 mw.

Studies have shown, he said, that noise is not affected by the interaction between plasma and beam. A noise factor of 30 to 40 db was obtained in his amplifiers at a few microns pressure, both with and without the beam. Professor Chernov believes that work on plasma amplifiers should and will be continued. At the present, however, no practical devices are in sight.

Cold-Cathode Source Pumps Portable Laser

MOUNTAIN VIEW, CALIF.—Spectra-Physics, Inc., reports successful operation of a portable laser designed for labs and classrooms that uses a cold cathode d-c pumping source instead of a conventional r-f source. It consumes 5 w, gives an output of 2 mw.

The company says high efficiency is due to elimination of an r-f excitation unit with its vacuum tubes and associated power losses in heaters. The device weighs 9½ pounds, compared with 55 pounds for the r-f-pumped version.

The classic problem of "cleanup" of the helium-neon gas in the laser tube was solved in part by going to a tube pressure of 5 Torr, or about five times as high as normal. Operating at 6,328 Å, the confocal resonator device will sell for "considerably under \$2,000."

In Brief . . .

ARMY IS GOING ahead with the Kathryn System, a flexible coding and decoding system for high-frequency intercontinental communication, designed to minimize interference. Fort Monmouth has just given General Atronics Corp. a follow-on research contract for \$47,205.

RUSSIA SAYS a defect in the orientation system has resulted in loss of radio contact with the Mars I space probe.

NEW TYPE of radio noise was discovered in signals telemetered from a two-stage rocket launched by Tokyo University. The low-frequency half-periodic noise originates in space and is most intense at 100, 17.44 and 5 Kc at altitudes between 100 and 200 kilometers.

SYLVANIA is readying a plan under which satellites will collect weather and oceanographic data from unmanned stations, buoys and balloons.

RAYTHEON received \$3.7-million contract from the Army for ABAR (Alternate Battery Acquisition Radar) radars.

CONTROL DATA CORP. has acquired Beck's, Inc., printed circuit manufacturer.

TELEPROMPTER Corp. is planning to sell its electronics manufacturing operations at Cherry Hill, N. J. to a group in investors.

NAVY IS ISSUING a \$1,568,188 contract to Texas Instruments for guidance control equipment and airframes for the Shrike radar-hunting and killing missile.

DOD is selling its Value Engineering Handbook for 40 cents. It will be available from the Government Printing Office, in Washington.

TRANSISTORIZED marine radar priced at \$2,650 has been developed by Decca Radar Ltd. of London. Its 3,000-w transmitter uses a 4-foot slotted waveguide antenna weighing 77 pounds.

NOW
AVAILABLE
WITH WELDABLE
LEADS

**RUGGED END-CAP
CONSTRUCTION FOR
LONG TERM STABILITY**

**EXCEPTIONAL RESISTANCE
TO MOISTURE
AND MECHANICAL
DAMAGE**

**SURPASS MIL-R-10509
PERFORMANCE
REQUIREMENTS**

AVAILABLE IN
REEL PACKING
FOR AUTOMATED
PWB INSERTION

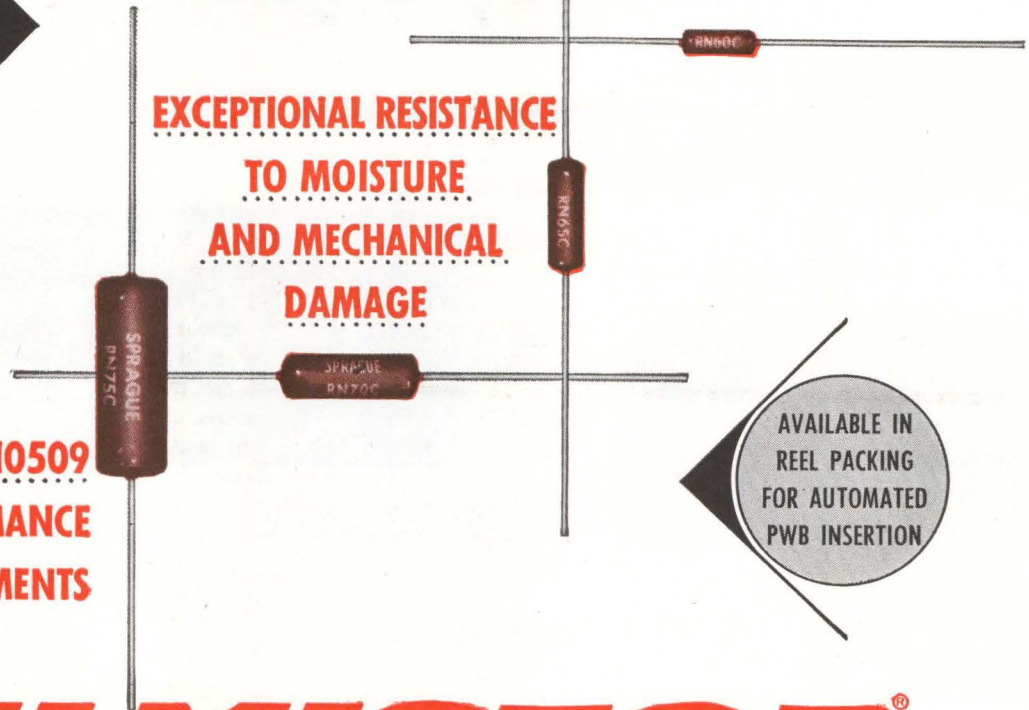

FILMISTOR[®] METAL FILM RESISTORS

**OFFER 5 DISTINCT
TEMPERATURE
COEFFICIENTS TO
MEET ALL CIRCUIT
REQUIREMENTS**

Providing close accuracy, reliability and stability with low controlled temperature coefficients, these molded case metal-film resistors outperform precision wirewound and carbon film resistors. Prime characteristics include minimum inherent noise level, negligible voltage coefficient of resistance and excellent long-time stability under rated load as well as under severe conditions of humidity.

Close tracking of resistance values of 2 or more resistors over a wide temperature range is another key performance characteristic of molded-case Filmistor Metal Film Resistors. This is especially important where they are used to make highly accurate ratio dividers.

Filmistor Metal Film Resistors, in 1/8, 1/4, 1/2 and 1 watt ratings, surpass stringent performance requirements of MIL-R-10509D, Characteristics C and E. Write for Engineering Bulletin No. 7025A to: Technical Literature Service, Sprague Electric Co., 35 Marshall Street, North Adams, Mass.

*For application engineering assistance write:
Resistor Division, Sprague Electric Co., Nashua, New Hampshire.*

SPRAGUE COMPONENTS

RESISTORS
CAPACITORS
MAGNETIC COMPONENTS
TRANSISTORS
MICROCIRCUITS

INTERFERENCE FILTERS
PULSE TRANSFORMERS
PIEZOELECTRIC CERAMICS
PULSE-FORMING NETWORKS
TOROIDAL INDUCTORS

HIGH TEMPERATURE MAGNET WIRE
CERAMIC-BASE PRINTED NETWORKS
PACKAGED COMPONENT ASSEMBLIES
FUNCTIONAL DIGITAL CIRCUITS
ELECTRIC WAVE FILTERS



'Sprague' and '®' are registered trademarks of the Sprague Electric Co.

Direct readout in: gpm, rpm, psi...

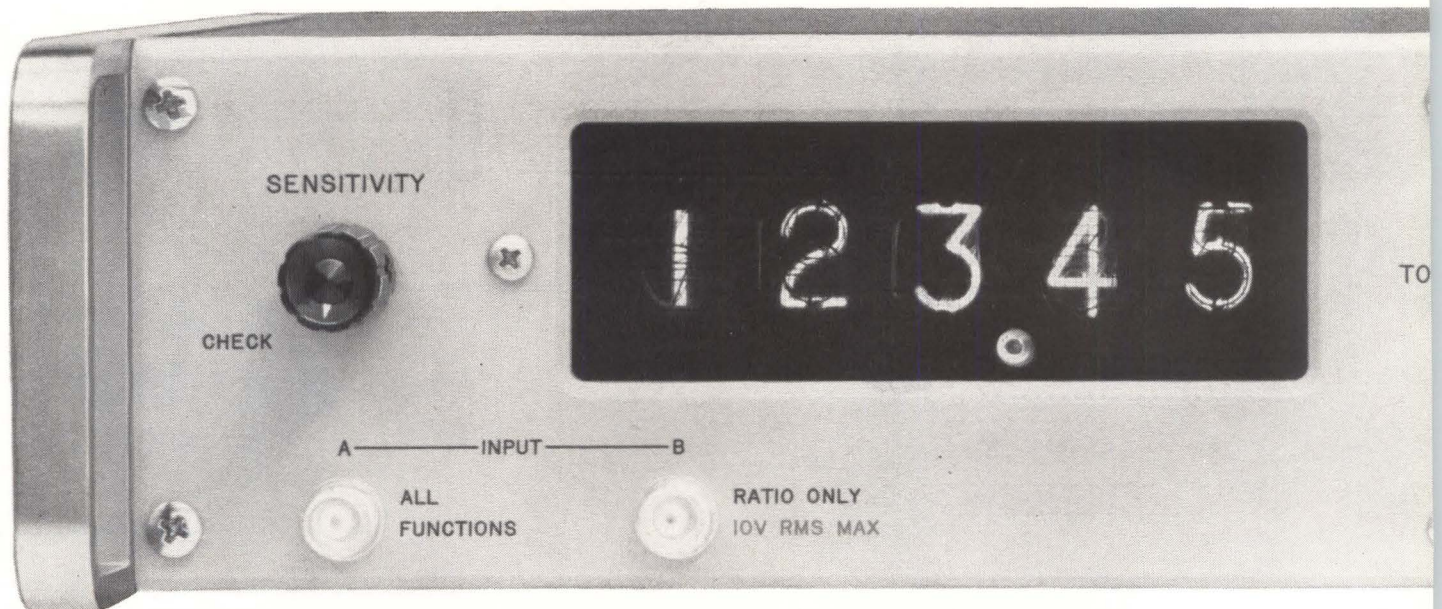

Measure, normalize, control... with the new

Today's most versatile electronic counter, in addition to measuring frequency and period and totalizing:

- measures normalized rate
- measures normalized time (period)
- measures ratio
- measures normalized ratio
- measures time for N events to occur
- counts N events, providing an output pulse at the start and end of the count
- N may be set to any integer from 1 to 100,000

Gallons per minute, pounds per hour, revolutions per second or minute — any event that can be converted to an electrical pulse can be measured in the exact units that are most helpful to your application. The ability to select gate times on the hp 5214L Preset Counter permits normalizing of any measurement.

For example, connecting a tachometer generator to a rotating shaft produces an output which is applied to the counter. Presetting the counter gate permits direct measurement of rps or rpm. Thus, if the tachometer generator produces 100 pulses per revolution, the gate would be set at $N = 1000$ (0.01 sec) to measure rps or $N = 600$ (0.6 sec) to measure rpm.

Besides making measurements common to most universal counters, the 5214L measures N periods;

measures ratio; measures normalized ratio; measures time for N events to occur; counts N events. This versatility is achieved by using two sets of decades, one of which registers the signal being counted, the other, which may be preset to any integer from 1 to 100,000 by front panel thumb-wheel switches, controls the gate. The number N also may be remotely programmed. Separate output signals are available to operate external equipment whenever the gate opens or closes. Since the 5214L can count N events, it is particularly useful in batching.

The 5214L measures ratio over a wide range of frequencies and with a wide choice of normalizing factors. The reading displayed is $N \times A/B \times \text{Multiplier}$. Hence, input B can be used as an external time base input for extending gate time or for normalizing an input signal so that percent change of input signal A may be read directly. The 5214L measures the time in milliseconds for N events to occur—period and multiple period measurements are made easily.

The solid state 5214L incorporates display storage, for continuous display of the most recent measurement and a flicker-free presentation on long life rectangular Nixie tubes. The four-line BCD code output with assigned weights of 1-2-2-4 is convenient for systems use.

Call your Hewlett-Packard representative for assistance in applying the remarkable 5214L Preset Counter to your particular measuring, recording and control problem. He will offer a demonstration at the same time.

you name it!



hp 5214L UNIVERSAL PRESET COUNTER

SPECIFICATIONS

FUNCTIONS

Totalize (input A): Range, 2 cps to 300 kc; sensitivity, 0.1 volt rms sine wave; 1 volt negative pulse, 1 μ sec minimum width; gate time, manual control; input impedance, 1 megohm, 50 pf shunt; capacity, 99,999 counts x Multiplier (1, 10 or 100); check, counts 1 kc, 100 cps or 10 cps

Rate (input A):

10 μ sec to 1 sec, 10 μ sec steps
100 μ sec to 10 sec, 100 μ sec steps
1 msec to 100 sec, 1 msec steps

Preset (input A): Input frequency range, 2 cps to 100 kc; preset range, 1 to 99,999; outputs, -30 volts to -1.3 volts transition at gate opening and gate closing; check, 100 kc counted, reads N

Time (input A): Input frequency range, 2 cps to 100 kc; reads, time for N events in msec; period and multiple period, reads time in msec for N periods; time base, 10 μ sec, 0.1 msec, or 1 msec; accuracy, ± 1 count \pm time base accuracy \pm trigger error*; check, 100 kc counted, reads time in msec for N cycles

Ratio (input A & B):

Input A: Frequency range, 2 cps to 300 kc
Input B: Frequency range, 2 cps to 100 kc; sensitivity, 0.1 volt rms sine wave; input impedance, 1 megohm; reads, $\frac{N_A \times \text{Multiplier}}{B}$; accuracy, \pm count; check, reads $N \times \text{Multiplier}$ (requires an input to B)

TIME BASE STABILITY

Internal:

Aging rate, $< \pm 2$ parts in 10^6
+15°C to +35°C, $< \pm 20$ parts in 10^6
-20°C to $\pm 65^\circ\text{C}$, $< \pm 100$ parts in 10^6
Line Voltage $\pm 10\%$, $< \pm 1$ part in 10^6

GENERAL

Maximum Counting Rate: 300 kc**

Registration: 5 long-life rectangular Nixie tubes with display storage

Sample Rate: Time following a gate closing, during which gate cannot be reopened, is continuously variable from less than 0.2 sec to greater than 5 sec in rate mode

Operating Temperature: -20 to +65° C

Dimensions: 16 $\frac{3}{4}$ " wide, 3-13/16" high, 13 $\frac{1}{4}$ " deep

Printer Output: Output, 4-line BCD (1-2-2-4); 1-2-4-8 code on special order; print command, step from -29 volts to -1 volt

Price: \$1475

*Trigger error (sine wave) = $\frac{0.3\% \text{ of one period}}{\text{number of periods}}$ for 40 db signal-to-noise ratio. Trigger error decreases with increased signal amplitude and slope.

**See detailed specifications under Functions

Data subject to change without notice. Price f.o.b. factory.

8475

**HEWLETT
PACKARD
COMPANY**



1501 Page Mill Rd., Palo Alto, Calif., (415) 326-7000. Sales and service representatives in principal areas. Europe, Hewlett-Packard S.A., 54 Route des Acacias, Geneva, Switzerland; Canada, Hewlett-Packard (Canada) Ltd., 8270 Mayrand St., Montreal, Que.

WASHINGTON THIS WEEK

PENTAGON WILL GRADE CONTRACTORS

SOMETIME THIS SUMMER, the Defense Department will initiate the "report card" system (ELECTRONICS, p 10, March 1) for evaluating performance of companies with at least \$5 million a year in development contracts. The records will influence future awards, target profits and reports to the Renegotiation Board. Military project managers will prepare six-month interim reports and a final one on contract completion. After departmental review and investigation, comment by the contractor, and further evaluation, reports will be centrally filed.

NAVY SET FOR MORE BIDDING

UNDER CONGRESSIONAL pressure, Navy is pushing plans to minimize sole-source procurement of electronic equipment. Special schedules for individual projects will provide timetables for delivery of prototypes and drawings and for introduction of competitive bidding. For example, Gilfillan is developing the AN/SPS-48 shipboard radar. Navy will buy 14 production models this year and 7 next year, and also have competitive bidding for 8 more next year. The AN/URC-32 h-f shipboard transceiver and AN/WRT-1 and -2 h-f shipboard transmitters will go competitive. So will Collins Radio's AN/PRC-38 vhf transceiver but buying volume is still under study because the radio is a modification of Collins' proprietary commercial model.

USSR HAS BIG DATA CENTER— WHY NOT U. S.?

SHOULD THE U. S. do like the USSR and centralize scientific and technical data handling and processing? A new *ad hoc* committee formed by Rep. Roman C. Pucinski, of the House Education and Labor Committee, is raising the notion—and whispering up a giant data center for Pucinski's home town, Chicago. He is impressed by VINITI, Moscow's giant abstracting, translating and information-handling institute, and has introduced legislation modeled on VINITI.

Testimony by information specialists before Pucinski's group may lead him to soft-pedal the approach. Favored are recommendations that science-sponsoring agencies upgrade their own data programs, serve as a focus for related nongovernment efforts and coordinate informally through interagency coordinators like the White House's Office of Science and Technology.

AEROSPACE SAYS ITS CUSTOMER ISN'T RIGHT

PROVOCATIVE ANALYSIS of the aerospace industry's unusual—often hectic—relationships with its one big customer, the government, is contained in a Stanford Research Institute study published by the Aerospace Industries Association.

It says industry is peeved by over-regulation and administrative bungling, by the Pentagon's unsympathetic view of profit rates and cost allowances, by mixing procurement with "socio-economic goals," and by policy inconsistencies like the stress on incentive contracting as opposed to Renegotiation Board actions. Aerospace producers are asked to encourage the government to stop over-managing by "suggesting simpler, more effective and less costly surveillance techniques."

SHRINKING PROFITS

RENEGOTIATION BOARD'S latest reports show that average earnings of defense contractors, before renegotiation and taxes, dropped from 6.3 percent of sales in 1956 to 3.1 percent in 1962.

Allen-Bradley Type J Variable Resistors used in constant impedance attenuators provide quiet, smooth control...at low cost!

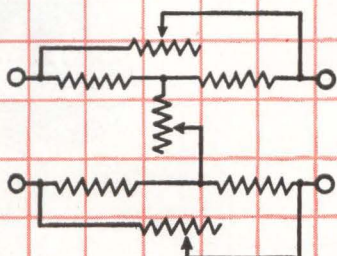
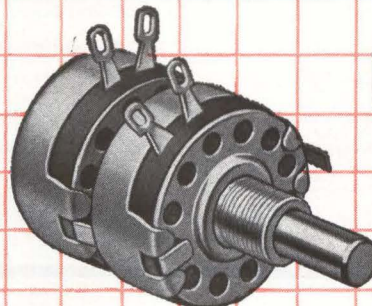
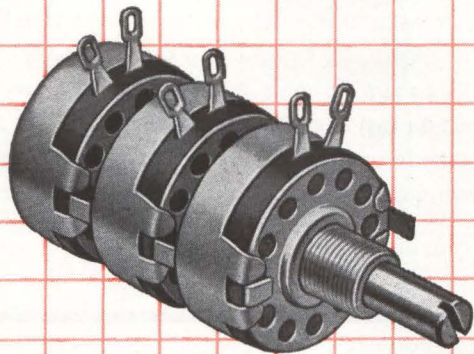

Bridged H

**Type JJJ
Actual Size**

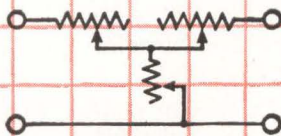

Straight T

**Type JJ
Actual Size**

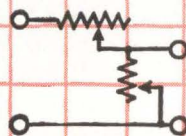

Standard L

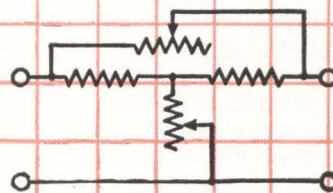

Bridged T

Reproduction of actual machine plot of Allen-Bradley 600 ohm Bridged-T attenuator, showing the uniform attenuation and constant characteristic impedance obtainable with such Type J variable resistors.

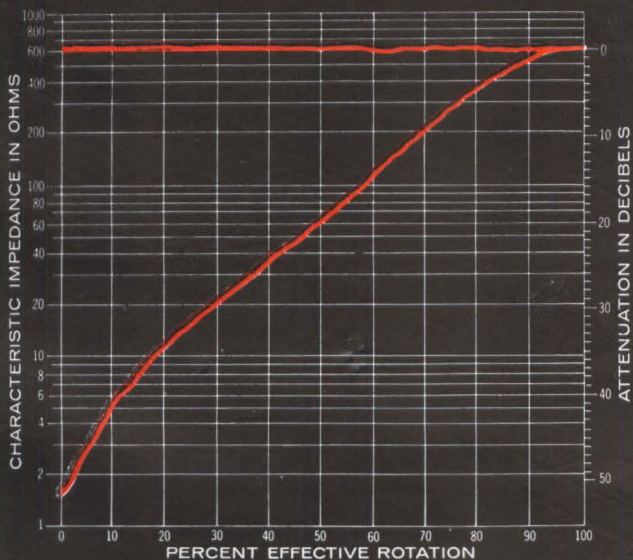

■ In attenuators, which of these characteristics is most important to you—stability, or smooth control, or constant impedance? Not only will Allen-Bradley Type J variable resistors give you all of these . . . but also long life and a high wattage rating in a remarkably compact structure.

The famous Type J solid resistance element—made by A-B's exclusive hot molding process—provides smooth control at all times—you'll never experience an abrupt change in impedance or attenuation during adjustment.

Allen-Bradley's control of the resistance-rotation characteristics during production assures the desired attenuation—approaching calibration accuracy. And, the characteristic impedance can be held to 10% throughout rotation—end to end! The discrete steps inherent in all wire-wound units are eliminated. Don't forget—freedom from inductance insures excellent high-frequency response.

The Allen-Bradley Type J variable resistors are available in dual or triple units for use in attenuators rated up to 5 watts. For more complete information on these Type J controls, please send for Technical Bulletin B5200B. Write: Allen-Bradley Co., 110 W. Greenfield Ave., Milwaukee 4, Wis. In Canada: Allen-Bradley Canada Ltd., Galt, Ontario.

QUALITY ELECTRONIC COMPONENTS

ALLEN - BRADLEY

Responsibility: Total capability...in support of aerospace programs USAF

Every facet of procurement, supply, maintenance engineering and transportation in support of aerospace and weapons systems for the Air Force is now the supervisory responsibility of the Air Force Logistics Command. The implications of such a vast assignment strain conceivability.

Responsibility so widespread—coupled with needs so urgent—demand the ultimate in preparation, experience and ability from the scientists, the engineers, the people of many different disciplines who carry out this mission.

The accelerating development of technology in support of aerospace and weapons programs and the immediate application of the technology is the concern of the civilian-military team of AFLC at ten different installations in various sections of the

country. Communications-electronics engineering and installation, inventory control, service engineering, a vast variety of projects relating to the total aerospace program are the business of every day at AFLC. The importance of accomplishing this business with dispatch is overwhelmingly evident.

AFLC employment benefits include patent protection for inventions, opportunity for advanced study, authorship credit on scientific papers, honorary, academic and cash awards, promotion based on merit, health and retirement benefit programs, low cost life insurance, paid vacations and sick leave.

If your qualifications are appropriate, we would be interested in discussing with you the unique career opportunities with Air Force Logistics Command.

AIR FORCE LOGISTICS COMMAND

has immediate openings for engineers and scientists in these areas. All positions offer full Civil Service status and benefits.

STAFF ARCHITECT—Will be responsible for conceptual design of facilities in which aircraft and missile components are calibrated, overhauled, repaired, assembled and tested.

ELECTRONIC ENGINEER—Will be responsible for solving complex engineering problems involving inertial guidance systems and stable platforms.

ELECTRONIC ENGINEER—Responsibility will involve the maintainability and reliability of electronic missile guidance and support systems.

PROFESSOR OF ELECTRICAL ENGINEERING—Will instruct at the USAF Institute of Technology highest level courses in theoretical and experimental electronics.

SUPERVISORY MECHANICAL ENGINEER—Will direct staff in developing advanced packaging and materials handling systems.

SENIOR OPERATIONS ANALYST—Will be responsible for carrying out difficult analyses in supply, maintenance, transportation, procurement, planning and programming.

To arrange an early interview, direct your resume or Application for Federal Employment (SF57) with geographical preference and salary requirement in strict professional confidence to:

United States Air Force
AFSC-AFLC Joint Professional Placement Office
527 Madison Avenue, Dept. F, New York 22, N. Y.
An Equal Opportunity Employer

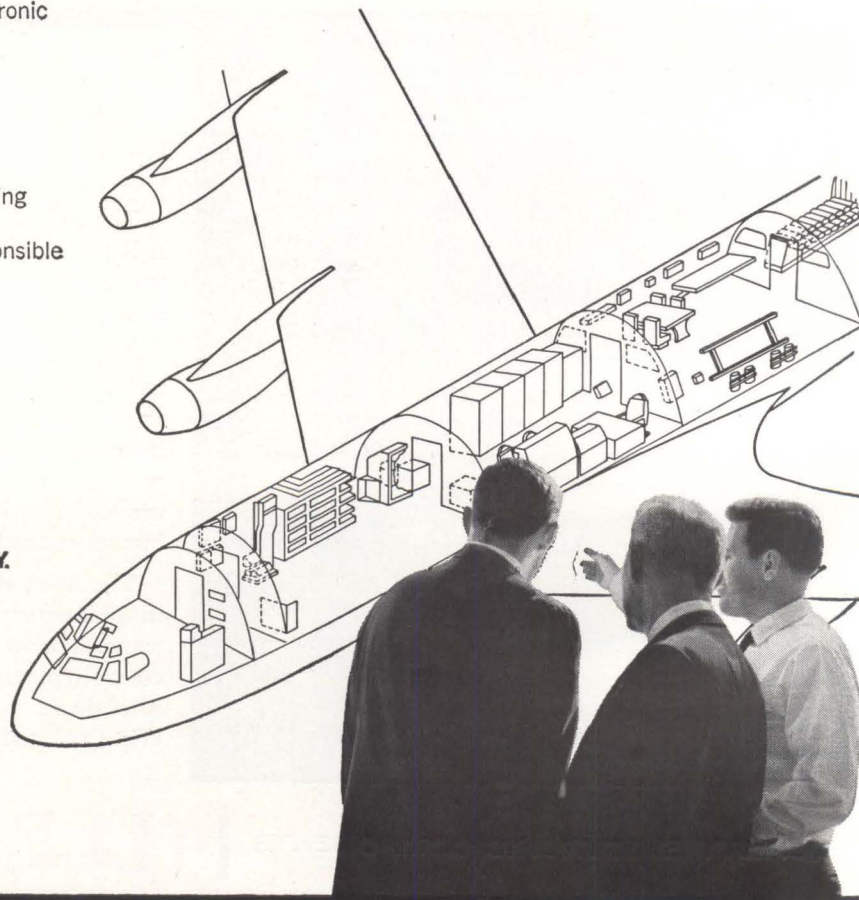

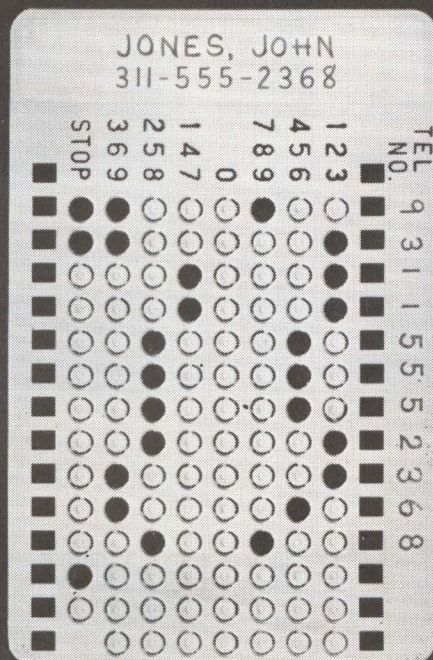
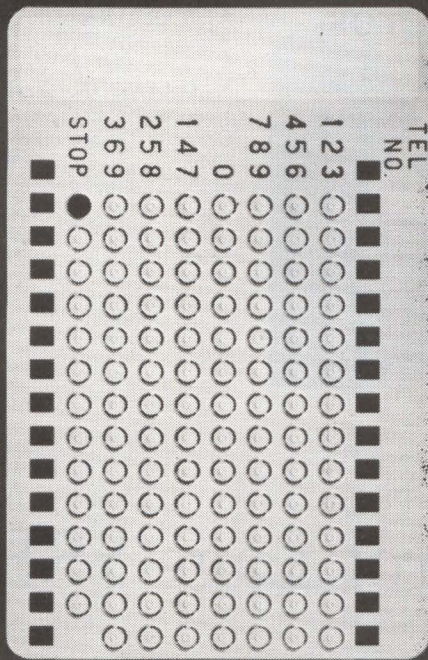

a card that remembers telephone numbers and dials them for you

How can you make a telephone remember numbers you often call and then dial them for you?

Engineers at Bell Telephone Laboratories are solving this problem in more than one way. One solution is the Card-Dialer telephone shown at the right. Here the required memory is in the form of economical plastic cards which fit into a slot in the telephone.

Each card contains a complete telephone number punched out in a simple pattern (see upper right). When a card is inserted in a Card-Dialer telephone, the recorded number is automatically dialed. To do this, the telephone senses the code on the card and generates a corresponding train of dial pulses. These pulses are then detected by central office equipment in the same way as those generated by a regular telephone dial. Simply by punching out the necessary holes with a pencil, you can prepare as many cards as you wish for both local or Direct Distance Dialing.

The new Card-Dialer telephone is now being manufactured for the Bell System by the Western Electric Company.

As the card is pushed down, the square holes engage sprockets which wind a spring. Then, as the card emerges, it contacts plastic rollers which detect the round holes and appropriately actuate a pulse generator. The 2-out-of-7 code is easy to use and does not require a costly sensing mechanism.

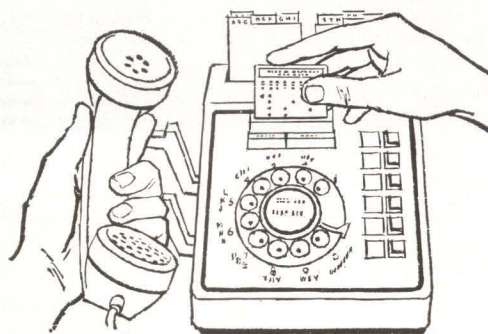

Bell Telephone Laboratories

World center of communications research and development



ALBERT KELLEY (second from right) with W. L. Doxey, Col. J. M. Kimbrough, Jr., and E. A. Gerber, of USAERDL. Kelley, director of electronics and control in NASA's Office of Advanced Research and Technology, said that while an estimated 70 percent of major spacecraft costs are for electronics, about 90 percent of flight failures arise from electronic failures

Frequency Control Lags SSB

Army wants better frequency standards for single-sideband use

By MICHAEL F. WOLFF
Senior Associate Editor

ATLANTIC CITY, N. J.—Need for crystal frequency standards capable of meeting the stringent requirements of Army portable ssb equipment and for more reliable atomic clocks was emphasized at the 17th Annual Frequency Control Symposium here last week.

Points were made by G. K. Guttwein, O. P. Layden and F. H. Reder, of U.S. Army Electronics R&D Laboratory, who surveyed progress and problems in quartz crystal R&D, quartz crystal circuits and measurements, and atomic frequency control, respectively.

New data on thallium and hydrogen standards were also reported at the symposium. Reports indicated that thallium may be more accurate than the cesium-beam standards.

QUARTZ CRYSTALS—USAE-RDL's most pressing frequency control problem is connected with new ssb equipment. In suppressed carrier ssb systems, maximum deviation between transmitter and receiver frequencies should not

exceed 50 cycles. At 70 Mc—highest frequency of present concern—required frequency-control stability is 3.5×10^{-7} .

Guttwein said power consumption must be reduced so stability requirements could be met in small frequency standards suitable for battery-operated, portable equipments. Power required for crystal ovens is prohibitive so the crystal should be used without an oven. But temperature control difficulties require more work on low-power ovens, temperature-dependent elements in the oscillator circuit, and direct electrical and mechanical compensation of the crystal unit.

Suppressing spurious modes in filter crystals is another problem.

Better ways to design above 60 Mc are required. Vhf crystal filters are needed, particularly 250-Mc filters for parametric up-converters.

Resistance to nuclear radiation is also important. Early experiments with pulsed nuclear reactors, showing crystals relatively insensitive to radiation, were contradicted in an actual nuclear weapons test. Gamma rays caused permanent frequency changes between 1.6 and 10 ppm.

ATOMIC CLOCKS—Poor reliability is the main enemy of all clock applications, Reder said. He wants top priority given to extending operational reliability to beyond 3,000-hour mtbf with 90-percent confidence and to getting five years average useful life. He also asked for simpler basic design and better production techniques to reduce clock price below \$10,000.

Two programs to provide users with attractive hardware are:

- Tactical rubidium gas cell clock is supposed to be delivered this fall by General Technology Corp. It will have outputs down to 1 pps, inaccuracy of 10^{-10} , lack of precision of 3×10^{-11} , and long-term instability of 5×10^{-12} under reasonable field conditions.

- Production capability for small, versatile high-performance cesium-beam standards is to be

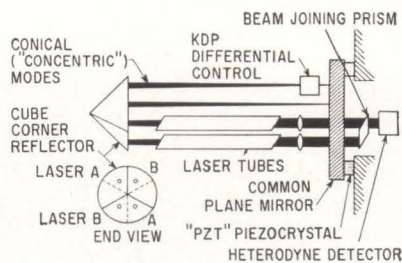

DOUBLE CAVITY for laser frequency standard described by Gordon Gould, of TRG, would have two independent laser oscillations going through the same reflector. Expected accuracy of locking onto center of spectral line is 1 part in 10^{11}

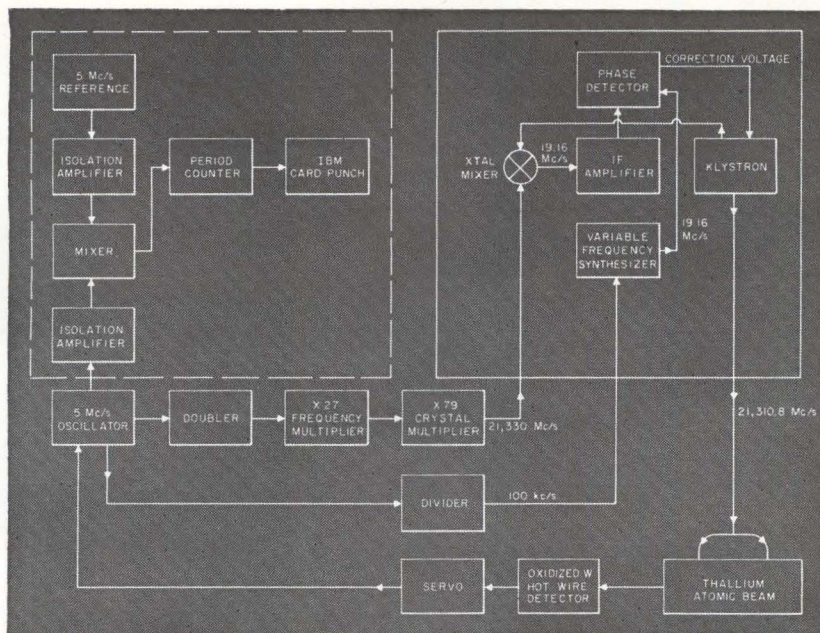

THALLIUM MEASUREMENT SYSTEM at National Bureau of Standards has phase-locked klystron loop to excite resonance

demonstrated by National Co. and Varian under a three-service-coordinated Air Force procurement. This is also expected to slash beam-standard prices through standardized and simplified production methods.

NEWS BREAKS—Technical developments arousing interest at the sessions included:

- Preliminary evaluation of the thallium-beam frequency standard (see illustration) reported by R. E. Beehler, National Bureau of Standards. It may offer improved accuracy and precision comparable to cesium-beam standards. Main advantage is that the contribution to inaccuracy produced by the magnetic C field is 1/50 as large for thallium as for cesium; main problem is that a more complicated detector system is needed.

Beehler reported precision of measurement typically 4×10^{-12} and occasionally 5×10^{-13} . He estimated accuracy could be made significantly less than 1×10^{-11} , said work would be accelerated.

- Comparison measurements made by beating two atomic hydrogen masers, presented by R. F. C. Vessot, of Varian. He reported rms deviation for hourly measurements over 45 days of 4.8×10^{-13} , stability as measured against Loran of 2×10^{-13} over 5 to 6 days and systematic drift be-

tween the masers less than 2×10^{-14} per day. More work is needed, but the maser may be the best practical device in terms of short-term stability.

- Microwave pulse-coherent technique that can be applied in a gas cell to artificially narrow the linewidth of the microwave resonance was described in a late paper by Maurice Ardit, of ITT Federal Labs. He said that for a rubidium cell a linewidth narrower than 15 cycles at 6,834 Mc had been obtained with good s/n.

Because there is no light frequency shift caused by pumping light, long-term stability one order of magnitude better than present gas cells is predicted.

- Developments in quartz crystals included showing for the first time how to measure directly the amplitude distribution of a shear mode crystal (G. Sauerbrey, Technical University of Berlin), use of parallel field excitation to eliminate transients that occur when crystal drive current or temperature is changed (A. W. Warner, Bell Labs), an x-ray extinction method that allows photographing lattice imperfections and internal stresses due to crystal vibrations (W. J. Spencer, Bell Labs), and a theory explaining the lack of interaction in multiple electrode filter crystals (W. Shockley, Cleveland).

POTTER
announces



*printer
division*

As part of our continuing effort to serve the needs of the rapidly expanding Electronic Data Processing field we take great pleasure in announcing the fact that our new printer facility is now fully operational.

The new Printer Division building increases our plant and production capacity by more than 65%, enabling us to provide you with faster delivery and better service. For example, we can now deliver our standard tape transports in 4 weeks and standard printers in 12 weeks from receipt of order. If you require fast delivery—with no sacrifice in performance or reliability—write us today.



POTTER INSTRUMENT CO., INC.
PRINTER DIVISION
East Bethpage Road • Plainview, New York
TAPE TRANSPORT DIVISION
151 Sunnyside Boulevard • Plainview, New York

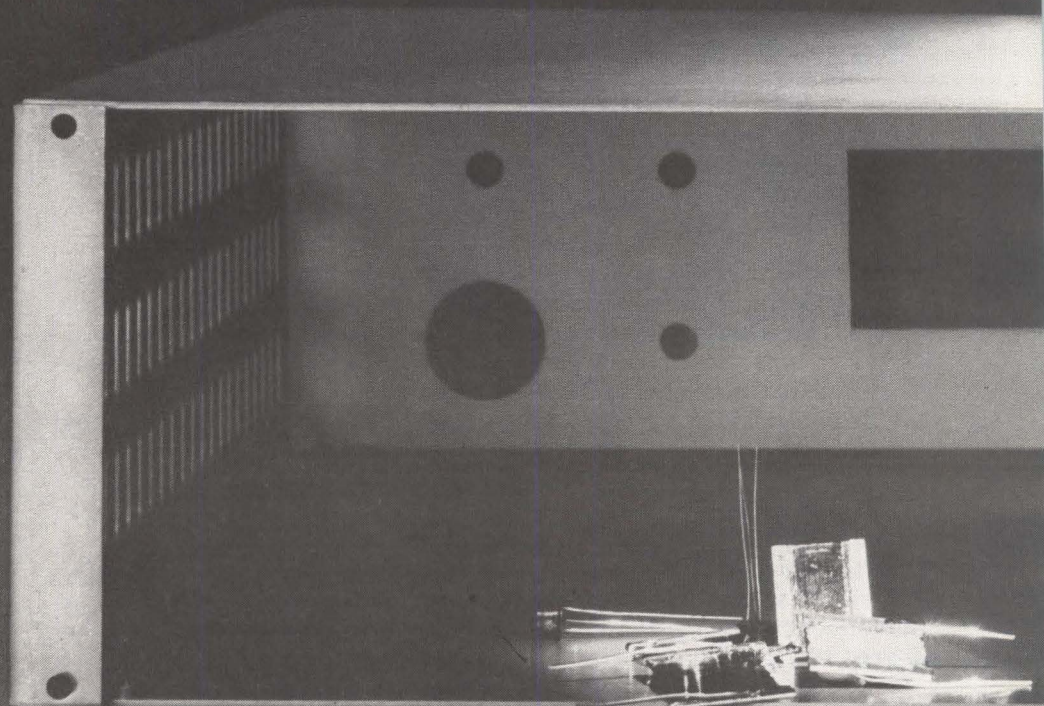

These are the "critical" components

All solid state—5 digit readout—fast—quiet—\$2795

An entirely new concept in circuitry design enables Hughes to bring you a digital voltmeter equal or superior in performance to devices priced at \$3000 to \$4000 or more.

The Hughes 5000 Digital Voltmeter is an all electronic solid state unit incorporating a new and unique voltage to frequency converter* as the heart of the machine. This device represents a breakthrough in the state of the art and practically eliminates the use of critical or trouble-making components. The result is a voltmeter offering remarkable reliability, the highest degree of accuracy and repeatability, and ease of maintenance.

Compare these specifications with any voltmeter on the market: Full 5 digit readout with .001% resolution.

Accuracy of .01% of reading...in-line display...10 readings per second from 100 microvolts to 999.99 volts. Fully automatic. All for \$2795. (See full specifications below.)

This remarkable unit is the backbone of a new line of digital measuring instruments which possesses complete capability for remote programming, printout, and system integration with a minimum of interface problems. The basic unit possesses a flexible output capability which prevents obsolescence. All remote programming and output driver circuitry is contained on one plug-in card which can be readily changed to meet a specific requirement. Under final development are ratio capability and auxiliary AC and ohms converters. These devices, like the basic DC machine, are designed for simple integration with existing scanner

in Hughes new digital voltmeter

and printout equipment to realize full system capability. We would like to demonstrate the Hughes 5000 Digital Voltmeter and prove to you that it is the best value on the market. Write, wire or call Hughes Instruments, 2020 Short Street, Oceanside, California. For export information write Hughes International, Culver City, Calif.

SPECIFICATIONS Hughes 5000 Digital Voltmeter

Ranges: ± 9.999 volts, ± 99.999 volts, ± 999.99 volts with full 5-digit readout. **Accuracy:** $\pm .01\%$ of reading or 1 digit. **Linearity:** $\pm .005\%$ of full scale. **Resolution:** $100 \mu\text{V}$ over entire lowest range. **Input Impedance:** 1000 megohms on ± 9.9999 volt scale, 10 megohms on higher ranges. **Features:** Automatic polarity; automatic ranging; 10 readings per second average. Faculty to incorporate automatic programming and printout. **Mechanical:** 5.25" panel height with 17" panel width. Detachable ears are provided for mounting in a standard 19" rack. *Pat. Pend.

HUGHES

HUGHES AIRCRAFT COMPANY
VACUUM TUBE PRODUCTS DIV.

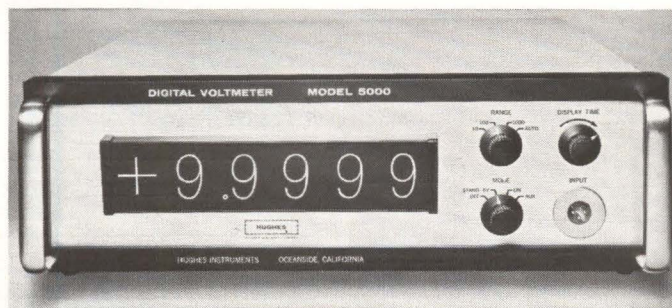

CIRCLE 19 ON READER SERVICE CARD

FORERUNNER of the TNDS system is North American Air Defense Command's big air-defense display at Colorado Springs

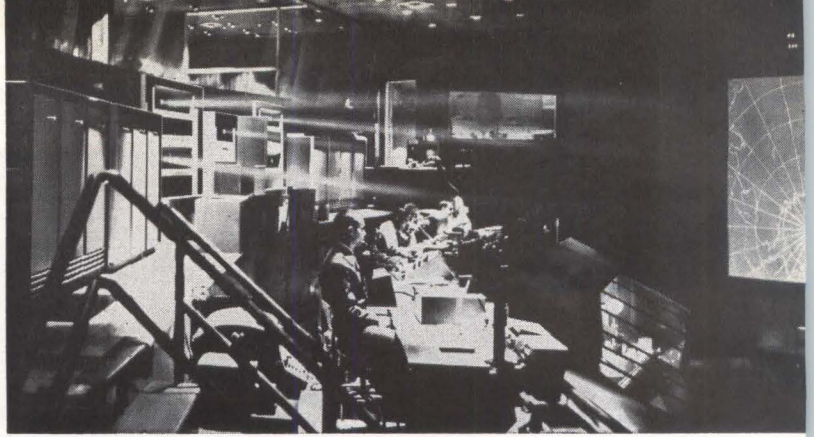

AIR-SEA-SUB

Display Plots Naval Targets

Scaled-down version of air-defense system goes aboard Navy combat ships

By MARVIN REID
McGraw-Hill World News

DALLAS—Modified and scaled-down versions of the air-defense displays used by Strategic Air Command are now going to sea. The *USS Essex* has one system and the *USS Kearsarge* will get another.

Called Tactical Navigational Display System (TNDS), the naval system was specifically designed to plot and record enemy surface, air and underwater movements at sea,

and display them to ships' officers in real time.

The information, color-coded for identification, is displayed on maps, oceanographic charts, geographic grid coordinates, or local tactical grids. Among the operating modes are:

- **Relative:** the ship is seen in the center of the screen and targets are displayed relative to the ship.
- **Geographic:** the ship's position, derived from the ship's dead-reckoning analyzer, is also shown as a moving track.
- **Navigational:** this also shows the ship on a moving track, but interchanges the position of the radar target and the ship, and provides a fix.

TNDS was developed by Ling-

Temco-Vought's Temco Electronics Display Systems plant, which has supplied some 60 systems for ground-air defense.

DATA GENERATORS—TNDS is essentially a multichannel, two-dimensional plotting system. Data is derived from five radar repeaters, a sonar repeater, the ship's navigational equipment and manual inputs.

What information is displayed, and how it is displayed, is determined by an evaluator who sits at a console facing the screen.

The display is generated by a battery of 10 projectors behind the screen: six plotting projectors, two spotting projectors and two reference projectors.

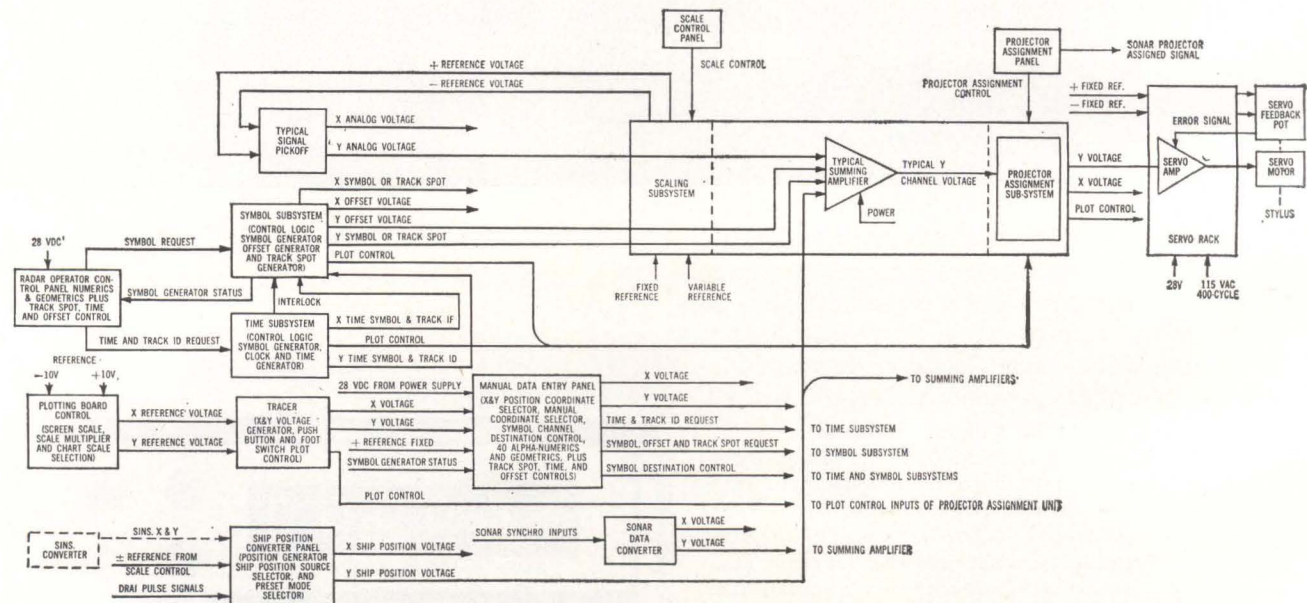

COMPLETE OPERATIONAL ORGANIZATION of the Tactical Navigational Display System. All inputs, plus a typical plotting channel are shown

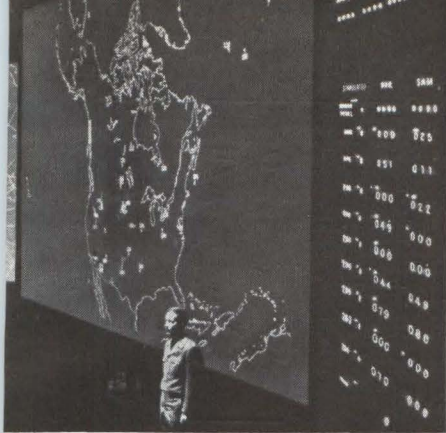

Target tracks are plotted automatically, from position signals that are generated when the repeater operators position their range strobes and cursors. Symbols identifying the targets are applied to the screen and manual inputs put additional information on the tracks.

HOW A CHANNEL WORKS—All channels are similar in operation. Here is how one displays a radar target:

When a radar operator positions his cursor over a target on the ppi, X and Y-coordinate voltages are automatically generated. An alert switch on the radar keyboard signals the evaluator—through a light on the alert panel—that information is available and waiting.

If the information is required for the plotted image on the screen, the evaluator may assign one of the plotting projectors to that radar. The coordinate voltages are fed to servo amplifiers in the projector's control unit and drive a plotting stylus to the correct position on a slide in a series of slides in the projector.

In the navigational mode, the

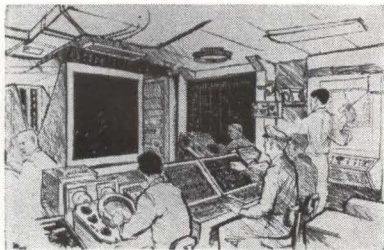

AUTOMATIC PLOTTING system replaces hand drawing of target tracks and data. Artist's rendering of TNDs shows, from left, repeaters, evaluation console and manual input board

X-Ray Vidicon

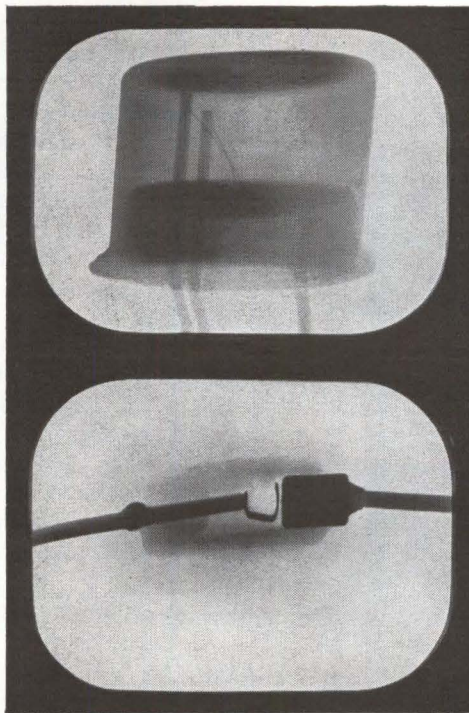

X-ray TV Image of metal-clad transistor and encapsulated diode—a typical non-destructive testing application.



High quality—static and in-motion—X-ray TV images . . .

The New ML-589 DYNAMICON is a 1" x-ray-sensitive vidicon camera tube which is capable of providing high contrast images with detail resolution down to 0.0005", and penetrometer sensitivities up to 2%, when used with an adequate CCTV system and x-ray source. Magnifications to 50X are easily obtainable. ML-589 is particularly suited for non-destructive testing and biological applications, permitting both static and in-motion examinations of small encapsulated components and materials such as plastics, ceramics, steel, aluminum, and rubber. For complete details write The Machlett Laboratories, Inc., Springdale, Conn. An affiliate of Raytheon Co.



PIT?

If you machine into a flaw in a Morris Bean casting, we'll replace the casting and pay you for lost machining time



request free Resources and Capabilities booklet
MORRIS BEAN & COMPANY, YELLOW SPRINGS 8, OHIO
 aluminum and ductile iron foundries

polarity of the X and Y voltages are reversed.

The evaluator assigns a color to the track, the stylus contacts the slide and the image is projected to the screen. If a continuous track is desired, the radar operator puts the plot control switch in continuous position and the stylus follows the cursor as the radar operator tracks the target.

With pushbuttons, the evaluator can identify the track with geometric symbols, time of day and track number.

Display scale can be 20,000 yards an inch, 15,000 yards, or system scale. The system scale is a potentiometer-controlled adjustable scale ranging from 500 to 10,000 yards an inch.

A manual plotting board can be employed. This usually involves

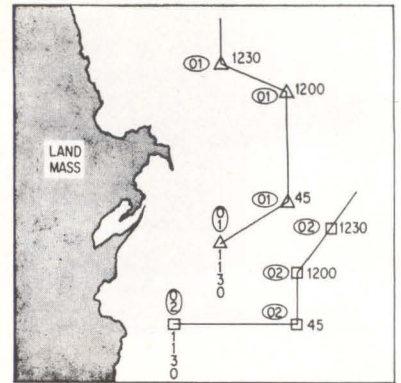

TARGET TRACKS are identified with symbols, numbers and position times

maps and charts. In this case, the plotting stylus in the projector follows the position of a tracing reticle over the information to be displayed.

Tv Set Size Shrinks

Two firms introduce 11-inch portables selling around \$100

BOTH GE AND ADMIRAL have made it official: their new home entertainment electronics lines will include lightweight, 11-inch television sets.

Both sets provide 60 square inches of picture area, both have earphone jacks for private listening, both come in polypropylene cabinets. GE has its set priced at \$99.95. Admiral says its 11-incher will be competitively priced.

Among design features in GE's

set is a new transistor continuous uhf tuner. The company says the set is available in vhf-uhf all-channel models. Admiral also announced a \$399.95 color-tv table model.

The two companies were among four introducing their new consumer electronics lines during the last two weeks. Others are RCA and Zenith. RCA has made numerous styling changes and refinements in its lines and introduced a 16-inch black-and-white portable tv priced at \$129.95. It has 21 color models listing at \$495 to \$1,700.

Zenith has several design features in its tv line. One is automatic fringe lock (ELECTRONICS, p 49, May 3). Another is a new tuner that can accommodate any mixture of 12 vhf or uhf channel strips and provides for continuously variable uhf tuning with or without remote tuning.

A peak picture control (see diagram) uses a variable resistor to change video detector load resistance for black-and-white sets or degeneration in screen video amplifier of color receivers. This, says Zenith, makes pictures lacking high-frequency response appear crisper or introduces smear to improve snowy pictures in fringe areas.

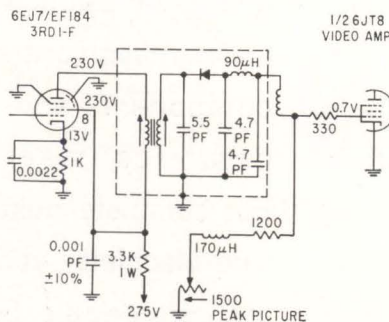

PEAK PICTURE control circuit used by Zenith to improve pictures

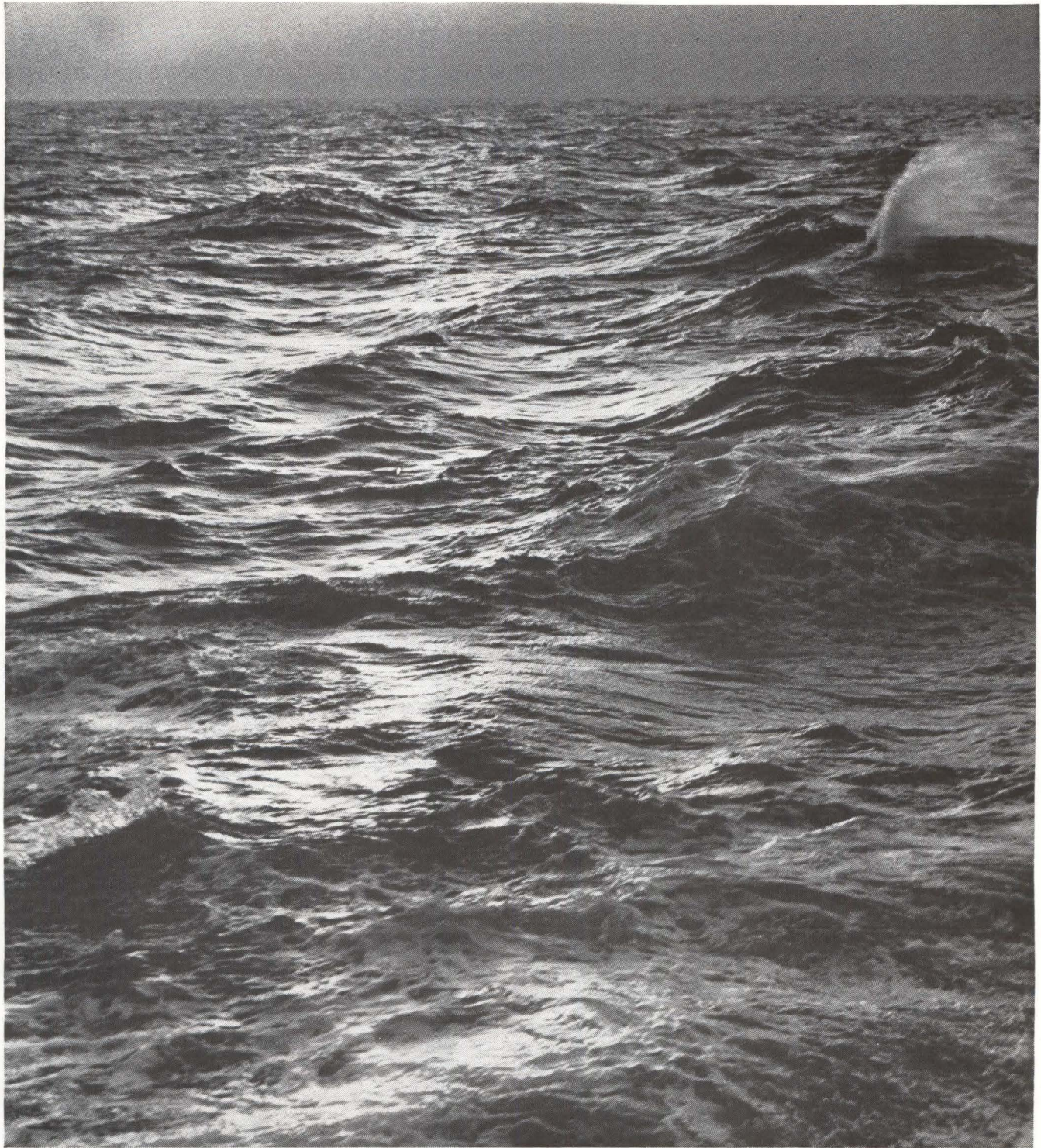

There's business out there.

You're looking at more than a horizon. It's a future, yours and America's. Out there is Europe and Latin America and Asia and Africa. But in 1960, of all U. S. manufacturers, less than 5% saw these foreign shores for what they are worth: a 19-billion-dollar export market, a vast source of foreign trade.

Move in for your share. Build your business and help keep America growing. Extra production creates more jobs, helps balance the outflow of gold, and wins new friends abroad with U. S.-made products.

Even if you've never sold overseas, you have a rare op-

portunity to start—now. Your U. S. Department of Commerce will help with counsel by experts on what, where and how to sell—with data on credits, payments and financing. A package of invaluable know-how is yours for the asking.

Now's the time to discover the many ways in which your business can grow. In the lucrative export markets. In new U. S. markets. In developing new products. In attracting new industry to your community. Just write or phone the U. S. Department of Commerce Office of Field Services in your city, or Washington 25, D. C. They are ready to help you grow with America!



NOW'S THE TIME TO GET GROWING IN A GROWING AMERICA!

Big Printed-Circuit Fight: Technograph Loses Round 1

Federal judge rules that Eisler patent claims are invalid

By DAN SMITH, Assistant Editor

AFTER DELIBERATING more than a year, a federal judge in Baltimore last week handed down the first legal decision on one of the most far-reaching patent fights in the history of the electronics industry. Judge R. Dorsey Watkins ruled that Bendix has not infringed rights claimed by Technograph for the manufacture of printed circuits. He also said that the patent claims of Technograph that were specifically at issue in this case are invalid.

NEXT CASE—But the fight is not over. Technograph plans to appeal the ruling and bring to trial in different U.S. District Courts similar suits against other companies. The cases of Packard Bell, to be tried in Los Angeles, and Admiral, in Chicago, are the most likely to come to court next. If Technograph should be successful in winning one of these, the matter would automatically go to the Supreme Court for a ruling.

If it lost, Bendix would be liable for "a million dollars or two" in past royalties plus possible future fees under the Technograph claims, according to Harold J. Birch, a Washington, D. C., attorney who represented Bendix in this matter. Bendix so far has spent about \$250,000 in legal fees and related costs on the court case, Birch said.

There is much more money at stake—\$20 million would be a conservative estimate, according to Hubert L. Shortt, president of Technograph Printed Electronics, Inc., a U.S. corporation affiliated with the British firm, Technograph Printed Circuits, Ltd., both of which are named as plaintiffs in the Bendix case.

71 MORE—Technograph has suits against 71 other firms, plus the U.S. government, for allegedly infringing its patent rights on printed circuits. The firms (see panel) almost make up the blue book of the industry.

Reaction to the Bendix decision among companies already licensed

by Technograph (see panel) was generally cautious. Patent counsels said they would need time to study Judge Watkins' 154-page opinion. One attorney commented: "I think much of the steam has gone from Technograph's drive." But another said: "I don't think our policies will be much affected."

Technograph has received more than \$1.5 million in royalties from firms it has licensed, according to Shortt. But it has not always been able to hold firms after the original license agreement ran out. According to Birch, who is also counsel for RCA, RCA paid Technograph \$75,000 in royalties over a five-year period but let its license lapse when it ran out in 1960. Burroughs told **ELECTRONICS** it had had a three-year agreement with Technograph but had not renewed it when it expired last December.

DESCRIPTION OF PATENTS—The patents involved in the Technograph suits were originally filed by Paul Eisler, an Austrian who emigrated to England in the 1930's. Judge Watkins ruled on Claims 1 and 2 of Patent 2441960; Claims 1, 2, 6 and 7 of Reissue Patent 24165 and Claims 4, 5, 10, 14, 15 and 16 of Patent 2706697.

Patent 24165 is the broadest of the three, claiming complete rights over the manufacturing and assembling of printed circuits and associated components. Patent 2441960 is directed to the manufacture of circuit boards where crossover connections are involved and Patent 2706697 is directed generally to the negative or metallic-resist process of making printed circuits.

In his opinion, Judge Watkins says ". . . that the patents were invalid in view of the prior art when the available literature, both patents and publications, not cited, is considered, and also the ability of persons unaware of the alleged inventions to reach the same results by the same means. The Court has no hesitation in holding the patents, and the claims in suit, to be invalid."

WHO IS SUED, WHO ISN'T

Technograph says it has filed suit against the following firms: Admiral, American Bosch Arma, Arvin Industries, Avco, Beckman Instruments, Bendix, Boeing, Bureau of Engraving Inc. and Colbuk Inc., Cohu Electronics, Computer Control Co., Inc., Consolidated Systems Corp., Croname Inc., Cubic Corp., Cutler-Hammer, Daystrom, Digital Equipment Corp., Electralab Electronics Corp., Electralab Inc. and Farrington Manufacturing Co., Electro Instruments Inc., Electronic Associates Inc., Electronic Engineering Co. of California, Electronic Specialty Co., Emerson Radio & Phonograph, Epsco Inc. and Monitor Systems Inc., Gates Radio Co., General Dynamics, GE, General Motors, General Telephone, General Time Corp., Goodyear Tire & Rubber, Hazeltine, Hewlett-Packard, Hoffman Electronics, Hughes Aircraft, Indiana General Corp., International Resistance Co., ITT, Laboratory for Electronics, Lear Siegler, Ling-Temco-Vought, Litton Industries, Lockheed Aircraft, McDonnell Aircraft, Magnavox, Martin-Marietta, Melpar, Methode Electronics, Minneapolis-Honeywell, Non-Linear Systems Inc., North Electric Co., Northrop Corp., Pacific Mercury Electronics Inc., Packard-Bell, Philco, Radiation Inc., RCA, Raytheon, Ryan Aeronautical, Sanders Associates, Sperry Rand, Systron-Donner Corp., Tattall Measuring Systems Co. and The Budd Co., Thompson Ramo Wooldridge, Travler Industries, United Aircraft, United-Carr Fastener, Warwick Manufacturing Corp., Webcor, Western Electric and Westinghouse.

Technograph says the following firms are its licensees in the U. S.: Alvic Products Co., Amerace Corp., Ampex, Baldwin-Lima-Hamilton, Bell & Howell, Collins Radio, Consolidated Electro-Dynamics, Ditto, Inc., Eastman Kodak, Formica Corp., General Precision, IBM, Link Aviation, National Cash Register, National Vulcanized Fiber, North American Aviation, Photocircuits Corp., Texas Instruments and ACF

MINIATURIZATION in MICROELECTRONICS

Super

SUPER SOLID CARBIDE MICRO-MINIATURE DRILLS
go right to the heart of the problem . . .

SUPER SUB-MINIATURE SOLID CARBIDE DRILLS IN MICRO-SIZES NEVER OFFERED BEFORE!

Previously made by Super in wire sizes to #80 (.0135") List 202, these solid carbide drills are now available in millimeter diameters from .34MM (.0134") including twelve sizes smaller to .23MM (.0091") List 202.

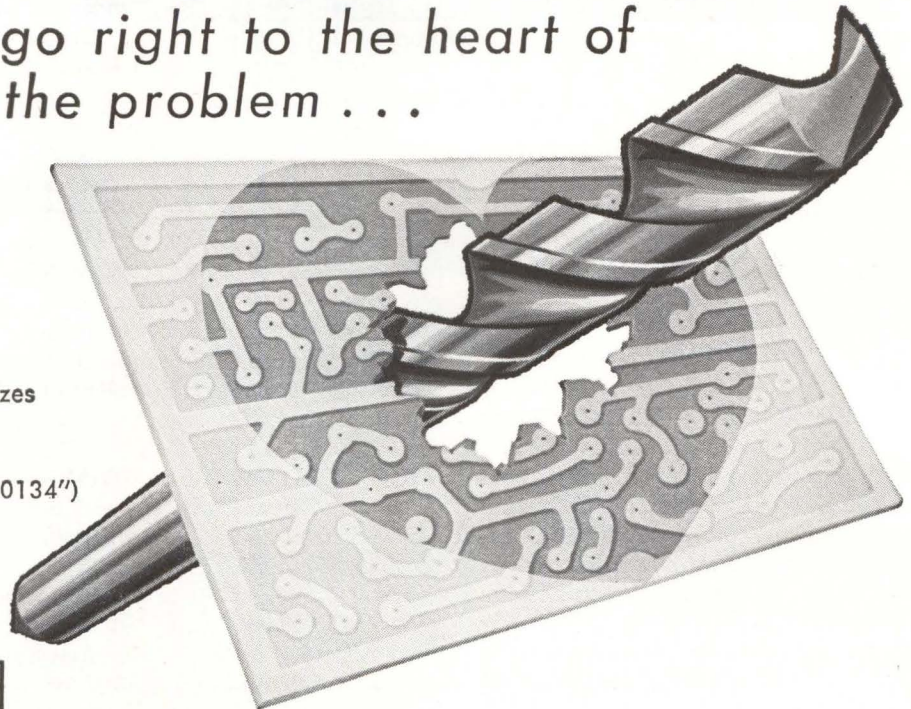

MM Size	Diameter Inches	Price
.34	.0134"	\$ 5.25
.33	.0130"	5.50
.32	.0126"	6.00
.31	.0122"	7.00
.30	.0118"	8.00
.29	.0114"	9.00
.28	.0110"	10.50
.27	.0106"	12.75
.26	.0102"	14.00
.25	.0098"	15.50
.24	.0094"	15.50
.23	.0091"	15.50

It is important to note that special equipment with definite accurate set-ups are required in the use of these items. Those of you who are familiar with miniature drilling techniques are aware of the fragile nature of these items and the personal care required. Should you have applications which may require these SUB-MINIATURES, kindly request our technical assistance which can be furnished promptly throughout the United States and Canada.

Super is also a leading producer of Solid Carbide Circuit Board Drills in general use throughout the electronics industry, our List 202 CB — Wire Sizes.

Kindly request General Catalog 63 detailing these and other associated items of interest throughout the electronics and metal cutting industries.

Super

SUPER TOOL COMPANY

DIVISION OF UNIVERSAL AMERICAN CORPORATION

• ELK RAPIDS, MICHIGAN

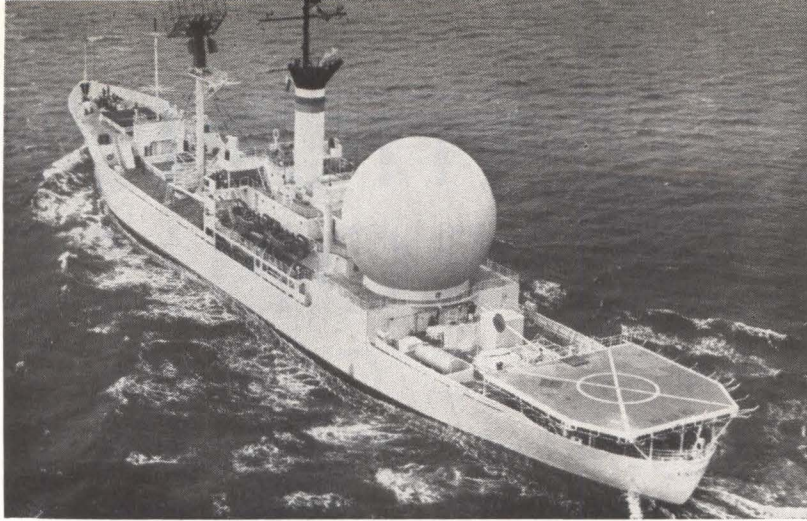

SATCOM'S Test Operations Center, Fort Monmouth, N. J., will manage the communications experiments

USNS KINGSFORT, equipped to track Syncom, will be modified and used for military net

*Prime contract awards
next month will launch
\$1/4-billion project*

By JOHN F. MASON
Senior Associate Editor

WASHINGTON — The military communications satellite program is expected to get moving next month when program definition phase contractors submit the results of their two-month studies to the Defense Communications Agency.

If the Defense Department's Director of Defense Research and Engineering decides to go into full-scale development of the experimental network—as is expected—USAF will select a prime contractor from one of its two study teams to build the satellites, and Army will name one of its three teams to build the transportable link terminals for the ground.

The program will cost up to \$250 million and will be completed by 1965.

The satellite contractors, which are responsible to the Air Force Systems Command's Space Systems Division (SSD), are General Electric and a joint venture consisting of Philco and Space Technology Laboratories. The ground gear candidates, supervised by the Army Satellite Communications Agency (Satcom), Fort Monmouth, N. J., are RCA, Sperry, and Hughes.

Besides developing the spacecraft, Air Force's SSD will integrate it with an Atlas Agena

DOD Satellite Net Set

booster system, conduct the launch, tracking, command, and control functions necessary to place the satellites in orbit.

HOW SYSTEM WILL WORK—The development system will consist of from 20 to 30 satellites orbiting the earth in several polar orbital planes at altitudes of from 5,000 to 10,000 miles. A single booster will launch from five to seven satellites, separating each one at slightly different velocities, causing them to spread out along the orbit in random fashion.

Since one satellite at an altitude of 5,000 miles is visible to two ground stations 8,500 miles apart, the system is expected to provide all areas of the earth access to one or more of the satellites most of the time. Minimum elevation of ground antennas will be seven degrees above the horizon to avoid poor transmission.

FEW CHANNELS—Although the military communications satellite system will use much of the demonstrated technologies of the Telstar, Relay and Syncom programs, there will be basic differences between these commercial type systems and a military network. Commercial satellites must provide hundreds of standard voice channels or one or two tv channels, while a military system needs relatively few channels for voice, tele-

typewriter and digital data. The first development satellites will provide only two voice and two teletypewriter channels.

The military satellite will be about 90-percent transistorized, it will be lightweight, and designed for long life. It will operate continuously whereas Telstar and Relay were turned on and off.

MOBILE TERMINALS — Commercial systems require large permanent terminals conveniently situated to concentrations of population. Some ground stations will be controlled by foreign governments. Terminals for military systems must be rapidly transportable to remote areas, such as underdeveloped countries where few if any communication systems exist. They require anti-jamming capability through higher transmitter power and a much greater ratio of frequency bandwidth to information bandwidth than is normal for commercial use. They must be survivable under physical or electronic attack.

Unlike synchronous satellites which hover over one spot on the earth, medium-altitude, random satellites move quickly and must be constantly tracked. They will carry a beacon for this, or else rely on the communications carrier frequency itself.

TRAFFIC CONTROL—A big prob-

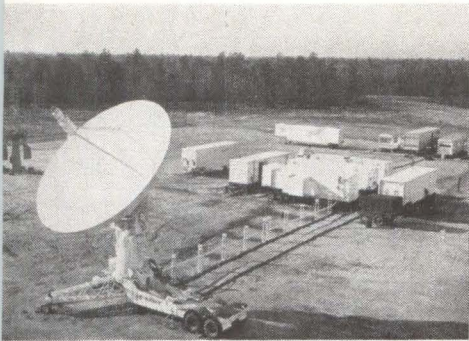

AIR-TRANSPORTABLE ground terminals may be similar to this 30-ft dish, 11-vehicle system built by Bendix for Syncom

for Awards

lem, for which definition phase contracts will be awarded next week to two or more companies, is how this world-wide, fast-moving, multi-station network can be controlled. A satellite communications control center, or centers, must provide each ground station with advance data on the time and location each satellite will appear over the horizon, and with the satellite channels available at any given moment. The magnitude of this contract depends on the complexity of the system finally selected.

EXISTING FACILITIES — Army ground stations that will be used for the military development system include four that are now being used for the National Aeronautics and Space Administration's Syncom satellite: 60-ft dishes at Ft. Dix, N. J. and Camp Roberts, Calif., the converted Liberty ship *USNS Kingsport* equipped with a 30-ft antenna, and an air-transportable terminal built by Bendix and located at Lakehurst, N. J. The Bendix terminal is contained in 11 vehicles and uses a 30-ft parabolic reflector. A similar system, by Bendix, is being checked out.

Other existing terminals that may be used include another air-transportable system by Bendix, now being checked out, and two ITT terminals at Camp Roberts, Calif. and Nutley, N. J.

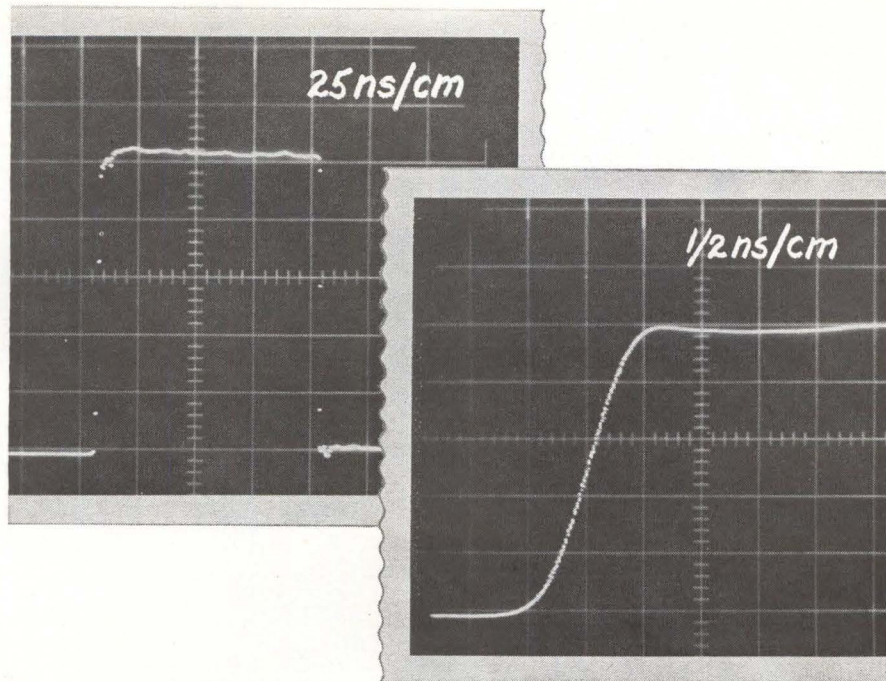

Proof! 1 amp avalanching in less than 1 nanosecond at 1 megacycle

High amplitude, high rep rate, fast rise/fall times are features of TI's Model 7101 Avalanche Pulse Generator. Voltage amplitude is variable to ± 50 volts into 50 ohms, rise/fall times are less than one nanosecond, repetition frequency is variable from 100 cycles to one megacycle. Ideal for advanced applications such as thin-film work, the 7101 furnishes selectable width pulses by means of plug-in modules from 5 to 100 nanoseconds or by external charge lines. Delay with respect to sync pulse is variable from 40 to 400 nanoseconds. Like all TI pulse generators, the Model 7101 is compact, lightweight and portable, extremely convenient to use. Circuitry is all solid-state. Write for complete information.

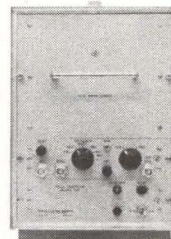

INDUSTRIAL
PRODUCTS
GROUP



TEXAS INSTRUMENTS
INCORPORATED
P. O. BOX 66027 HOUSTON 6, TEXAS

SENSING • RECORDING • TESTING • DIGITIZING INSTRUMENTS
THE INSTRUMENTS OF TEXAS INSTRUMENTS

601
CIRCLE 27 ON READER SERVICE CARD

**HELP YOUR POST OFFICE
TO SERVE YOU BETTER
BY
MAILING EARLY IN THE DAY
NATIONWIDE IMPROVED MAIL SERVICE
PROGRAM**



Model 115 Continuous-Wave Gas Laser

WHAT TO LOOK FOR IN A LASER

A laser is more than a beam of light, more than just a laboratory toy. Just how much more depends upon what you look for. These parameters of CW gas lasers are worth your looking into:

Wavelengths Will one or two be sufficient? The Perkin-Elmer/Spectra-Physics Model 115 provides three; visible and infra-red: 6328Å, 11,523Å, and 33,912Å.

Power Is specified power for multi-transverse mode or single transverse mode wavefront? Most lasers are incapable of operation in the lowest order transverse mode. The Model 115 produces at least one milliwatt of power in a uniphase, lowest-order mode. This specification is also a measure of optical quality.

Adjustability Can you make precision adjustments of both resonator length and reflector angle? The Model 115 resonator is precisely adjustable over 2 cm in length and adjusts in reflector angle to 0.1 arc second resolution.

Precision in construction and alignment—A good test is whether it is possible to operate the laser in the plane-parallel resonator configuration. This is also a revealing index of the laser's stability.

Exciter Is it designed specifically for laser use? If it is, as in the Model 115, control will be simpler and you'll avoid problems arising from misadjustment of needless controls.

Warranty Is the laser guaranteed? Who made it? How many has he made? Who's now using them? Over 70% of all commercial CW gas lasers in use today were developed and produced by Spectra-Physics. The Model 115, backed by an unmatched continuity of experience and user-proved performance, carries a complete warranty (including plasma tube).

Price Most lasers are worth what they cost; you can buy some for under \$1000. But if you want the quality and serviceability of a precision laboratory instrument, you'll find the Model 115, with a price tag of \$4650, to be the best value available today.

DEMONSTRATION Have you seen the Model 115 in operation (or the higher-powered Model 112)? Drop us a note (or call collect) for a demonstration in your lab. Meantime, we'd like to send you our newest product brochure and put your name on the list to receive future applications bulletins.

SPECTRA-PHYSICS
INC.

738 Terra Bella/Mountain View 3/California
(415) 968-4467

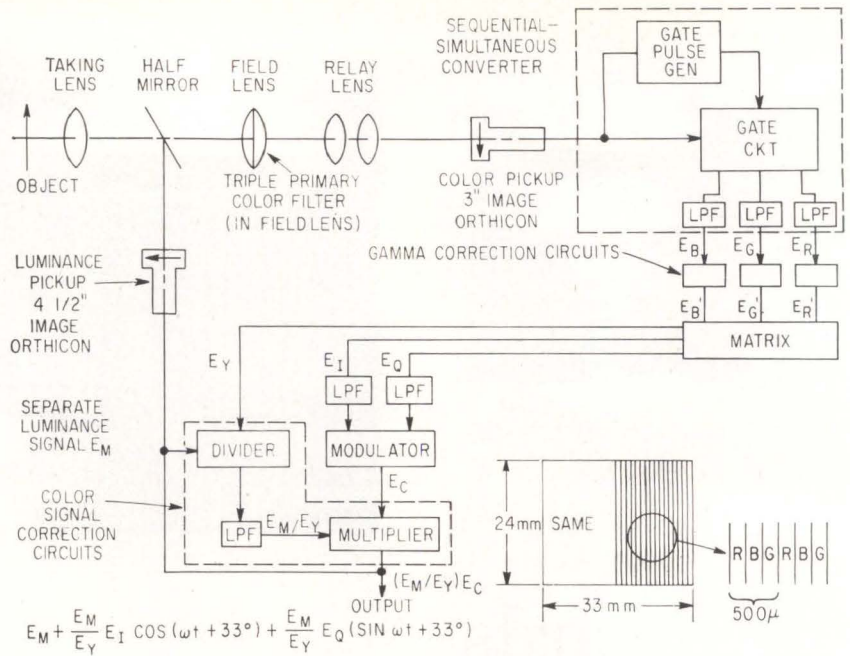

(A) IMAGE IS SPLIT for luminance and color pickup. NTSC color signals are generated by combination of color filter, image orthicon and gating circuit (A). Filter consists of alternating red, blue and green color stripes (B)

Two-Tube Color Camera

One image orthicon handles color, other is luminance pickup

TOKYO—Japan's answer to the new four-vidicon color-tv cameras developed in the U.S. may be a camera using only two image orthicons and a special filter to generate NTSC color signals.

The two-orthicon camera is now in development at the Technical Research Laboratories of NHK, Japan's government broadcasting system. An experimental prototype in operation at the lab produces pictures that are "quite promising."

The U.S. cameras add a fourth vidicon as a luminance tube to sharpen color and black-and-white picture quality (ELECTRONICS, p. 42, April 12). NHK's camera also has separate luminance and color pickup, plus the added prospect of being only two-thirds the size of conventional cameras using three image orthicons.

- Other advantages claimed for the camera are:
- Improved resolution and signal-to-noise ratio for better color
 - Improved black-and-white com-

- patibility, improved color shading and stable white balance
- Possibility of good color transmission with relatively low illumination, about 2,000 lux
 - Registration adjustments is simplified by using only two tubes.

OPERATION — A half-silvered mirror directly behind the front camera lens (see diagram) splits the incoming light from the scene being televised into two parts. Half of the light falls directly on the 4 1/2 inch image orthicon of the luminance channel. The other half goes through an optical filter with alternate vertical stripes of the three primary colors. The filtered image strikes the color-channel's 3-inch image orthicon.

The vertical stripes of primary colors in the optical filter cause the output of the image orthicon to be a sequential color signal. The three primary color signals are separated in a gate circuit and passed through low-pass filters to obtain a three-color simultaneous color signal. Color signal bandwidth is 500 Kc.

IMPROVED FILTER—Generation of the gate pulse is the camera's most difficult design problem. Dur-

**LOW COST
INSURANCE
AGAINST
TRANSIENT
VOLTAGE**

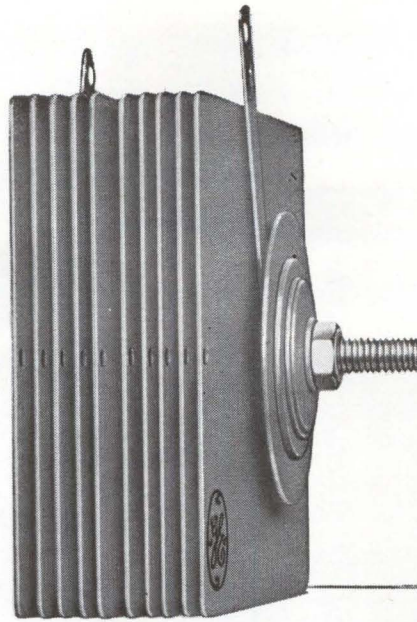
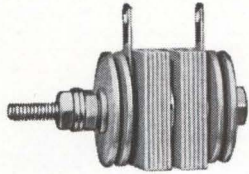

GENERAL ELECTRIC THYRECTOR DIODES

NOW AVAILABLE IN A COMPLETE LINE OF CELL
SIZES CAPABLE OF HANDLING UP TO 300 AMPS
DISCHARGE CURRENT

Increase circuit reliability at lower cost . . . reduce the possibility of expensive equipment breakdown! With G-E Thyrector Diodes, design engineers can now *know* the values to which transients will be limited in their circuit, can select silicon and germanium components rated to operate under known transient values, and can select their components according to *actual design requirements* instead of using over-rated devices.

G-E Thyrector Diodes are specially manufactured selenium semi-conductors whose reverse characteristics have been designed to provide

a sharp I vs. E trace, making them ideal for voltage surge suppression applications. They offer instantaneous voltage response, relative insensitivity to temperature, non-linear resistance and stability with use. Unlike selenium rectifiers, Thyrector Diodes in AC shunt protection circuits do not age, so they offer transient voltage protection for a virtually unlimited period of time. Six basic Thyrector Diode types are available with shunt protection current ranges from 7.5 amperes to 300 amperes. *And one Thyrector Diode can often save you 10, 20, or even 40 times its cost!*

INSTANTANEOUS VOLTAGE RESPONSE

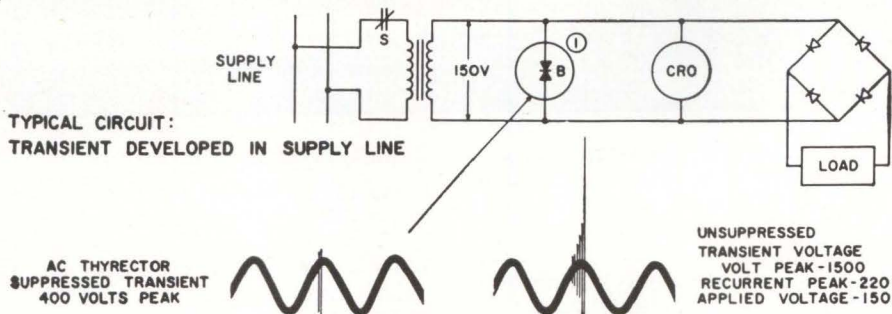

Rectifier Components Department, Section 16F65-R
General Electric Company, Auburn, New York

Please send me FREE complete information on General Electric Thyrector Diodes.

Name _____ Job Title _____

Company Name _____

Address _____

City _____ Zone _____ State _____

Available through your G-E
Semiconductor Distributor

GENERAL  ELECTRIC

MALLORY PACKAGED RECTIFIER CIRCUITS CUT YOUR COSTS, IMPROVE RELIABILITY



A Mallory doubler or a full-wave center-tap package costs less than two rectifiers . . . a Mallory full-wave bridge costs less than four rectifiers.

You have fewer pieces to handle, fewer soldered connections to make. At a labor rate of \$1.60 per hour, for example, you can expect additional savings of \$300 on your production line for 25,000 doubler packages, compared to 50,000 single rectifiers. And you reduce your purchasing, handling and stocking expenses.

Circuit reliability is increased, because of the reduction in soldered connections . . . one less on a doubler or full-wave package, two less on a bridge.

A comprehensive line of Mallory rectifier packages is available. All are based on our unique cell construction which gives exceptional reliability, low forward drop, low reverse leakage, and excellent temperature

stability. All come in ratings from 50 to 600 volts.

Encapsulated models, with cold case design, include Type FW full-wave bridge, rated 1.0 ampere at 100° C; Type VB voltage doubler, rated 0.5 ampere at 100° C; and Type CT full-wave center tap, with either positive or negative polarity, rated 1.0 ampere at 100° C. New economy-priced packages, rated for 85° C, include the Type VBM doubler with 0.35 ampere rating, and the Type CTPM full-wave center tap circuit, rated 0.70 ampere.

Hermetically sealed models, in standard E.I.A. package, include doubler and full-wave center-tap types, also rated 0.5 ampere.

Write to us for data and for a consultation on your circuit requirements.

Mallory Semiconductor Company, Du Quoin, Illinois, a division of

Silicon rectifiers • Packaged rectifier circuits • Zener diodes • Silicon controlled rectifiers

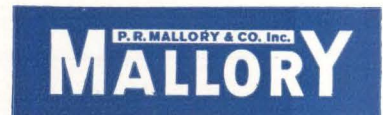

See your franchised Mallory Distributor for Mallory rectifier packages Encapsulated Types

**"VB" Voltage Doubler
(0.5 Amperes I_F @ 100°C)**

Mallory No.	Max. PRV	Max. RMS Volts
VB50	50	18
VB100	100	35
VB200	200	70
VB300	300	105
VB400	400	140
VB500	500	180
VB600	600	210

**"CT" Full-Wave Rectifier
(1.0 Amperes I_F @ 100°C)**

Mallory No.	CT Neg.	CT Pos.	Max. PRV	Max. RMS Volts
CTN50		CTP50	50	18
CTN100		CTP100	100	35
CTN200		CTP200	200	70
CTN300		CTP300	300	105
CTN400		CTP400	400	140
CTN500		CTP500	500	180
CTN600		CTP600	600	210

**"FW" Full-Wave Bridge
(1.0 Amperes I_F @ 100°C)**

Mallory No.	Max. PRV	Max. RMS Volts
FW50	50	35
FW100	100	70
FW200	200	140
FW300	300	210
FW400	400	280
FW500	500	350
FW600	600	420

**"VBM" Voltage Doubler
(0.35 Amperes I_F @ 85°C)**

Mallory No.	Max. PRV	Max. RMS Volts
VBM50	50	18
VBM100	100	35
VBM200	200	70
VBM300	300	105
VBM400	400	140
VBM500	500	180
VBM600	600	210

**"CTM" Full-Wave Rectifier
(0.7 Amperes I_F @ 85°C)**

Mallory No.	CT Neg.	CT Pos.	Max. PRV	Max. RMS Volts
CTMN50		CTMP50	50	18
CTMN100		CTMP100	100	35
CTMN200		CTMP200	200	70
CTMN300		CTMP300	300	105
CTMN400		CTMP400	400	140
CTMN500		CTMP500	500	180
CTMN600		CTMP600	600	210

Metal case, hermetically sealed types

**"VBH" Voltage Doubler
(0.5 Amperes I_F @ 100°C)**

Mallory No.	Max. PRV	Max. RMS Volts
VBH50	50	18
VBH100	100	35
VBH200	200	70
VBH300	300	105
VBH400	400	140
VBH500	500	180
VBH600	600	210

**"CTH" Full-Wave Rectifier
(1.0 Amperes I_F @ 100°C)**

Mallory No.	CT Neg.	CT Pos.	Max. PRV	Max. RMS Volts
CTHN50		CTHP50	50	18
CTHN100		CTHP100	100	35
CTHN200		CTHP200	200	70
CTHN300		CTHP300	300	105
CTHN400		CTHP400	400	140
CTHN500		CTHP500	500	180
CTHN600		CTHP600	600	210

Write us for the name and address of the Mallory Distributor nearest to you.

**Mallory Distributor Products Company
P. O. Box 1558
Indianapolis 6, Indiana**

CIRCLE 31 ON READER SERVICE CARD
electronics • June 7, 1963

ing initial experiments the pulse generator was synchronized by sync pulses at the beginning of every sweep cycle.

In present experiments a filter that has a black stripe before every color-stripe triplet is used to generate synchronizing pulses. Stabil-

ity is improved. Width of the black stripe is 140 microns, width of the color stripes is 110 microns each; total width of the black stripe and three color stripes is 470 microns.

Fabrication of the stripe filter is difficult. Colors of stripes on experimental filters are not yet optimum.

Varactor Cutoff 800 Gc

GaAs diode formed in waveguide raises frequency limit 300 Gc

LOS ANGELES—Report on a varactor diode with a cutoff frequency of 800 Gc at zero volts bias—300 Gc higher than the presently accepted limit—sparked considerable interest among the 600 registrants at the microwave symposium sponsored May 20 to 22 at Santa Monica by the IEEE-PTGMMT.

B. C. DeLoach, of Bell Telephone Labs, feels that use of the diode should extend the range of parametric devices well into the millimeter region. He gave details on how the electrically formed gallium-arsenide (0.003 ohm-cm) crystal diode is directly fabricated in waveguide.

At 0.65 bias voltage, R_s is 13.5 ohms, C is 0.022 pf and L is 0.4 nh. At zero bias voltage, the values are about 12, 0.016 and 0.41, respectively. Reverse bias breakdown voltage is about 7 v.

Another Bell Labs development, described by M. R. Barber, is a high-power protector for varactor diodes in low-noise parametric receivers. It uses two quarter-wave-space *pin* diodes (see diagram).

Ratings include 70-db isolation with 0.16-db low-level loss, 1-Kw continuous r-f power and 100-Kw peak power. *Pin* diodes are applicable to high-power switching, it was pointed out, because their microwave impedance is essentially a controllable conductance in shunt with a nearly constant capacitance. This conductance rises to as high as 10 mhos.

M. D. Coleman, of Mullard Research Labs, reported on a practical 4-port, crossed-junction, wave-

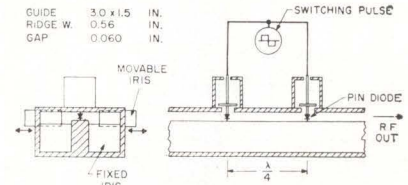

SOLID-STATE switched protector is designed to protect varactors in parametric receivers

guide circulator. While electrical characteristics do not yet match 3-port types, the new device has size and weight advantages. Successful operation at 3 Gc, 9 Gc and 20 Gc was disclosed.

Eight modes of circulation were shown for the circulator. Circulation can be obtained in opposite directions at two different frequencies with a constant value of applied magnetic field. With two different field values, circulation in the same direction is achieved.

Computers Will Control Tv Broadcast Centers

BOTH CBS AND NBC television networks are installing computer control systems in tv broadcast centers. While the systems differ, both will largely automate the compiling of preplanned programs from studio audio and video facilities and handle on-air continuity.

CBS will use two Thompson Ramo Wooldridge TRW-330 computers at its New York broadcast center, scheduled to go on the air early in 1964. NBC will install a Daystrom 636 in its Burbank, Calif., center. The 636 will be pro-

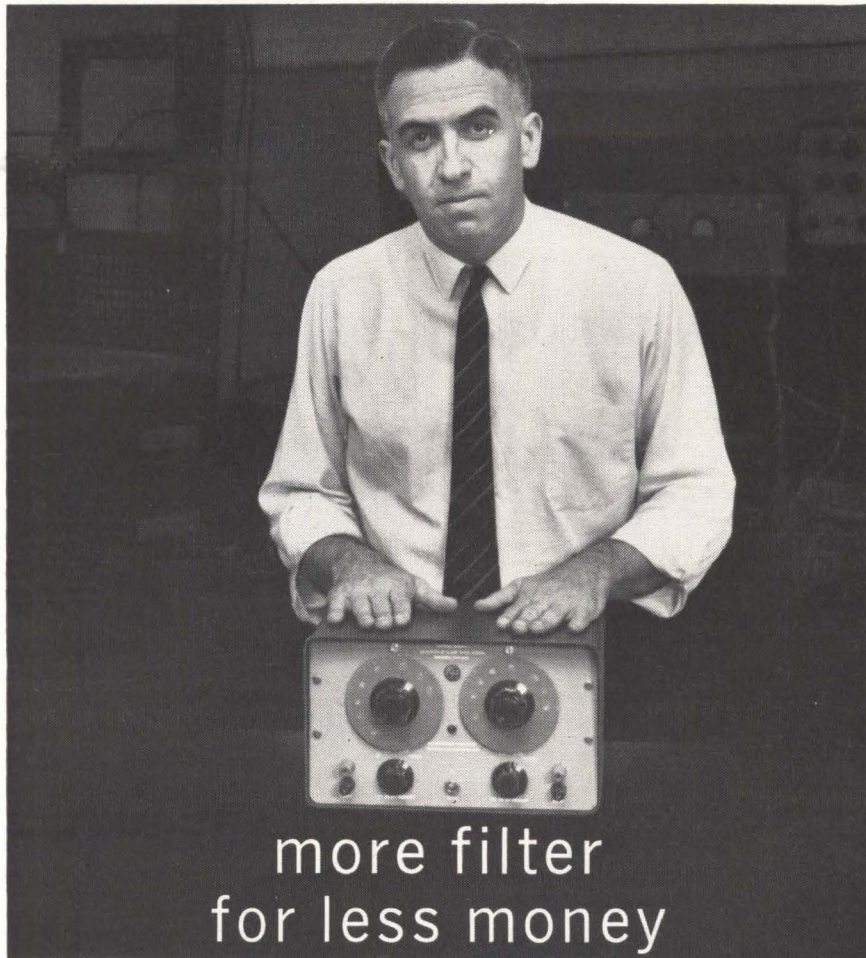

more filter
for less money

the Model 310-AB!

Look at all the features Krohn-Hite packs into one low-cost filter! Krohn-Hite's Model 310-AB variable band-pass filter covers the range from 20 cps to 200 kc. It features continuous independent adjustment of the high and low cut-off frequencies, so that the center frequency and band width are both adjustable.

Slope is 24 db per octave. Dials are direct-reading for quick and accurate measurement. Cut-off frequency accuracy is $\pm 10\%$, with $\pm 5\%$ available.

A big advantage of the Model 310-AB is its high input impedance. It can be bridged across sensitive circuits without disturbing them. Its low output impedance is another advantage, and the output doesn't require terminating in a specific load.

Low noise is another feature of the 310-AB. Its hum and noise spec is that of other much more expensive filters (less than 0.25 millivolt rms), allowing the filter to work at low signal levels.

How does Krohn-Hite put so many features into a \$350 filter? Easy — Krohn-Hite are filter *specialists* — the first to introduce many filtering techniques now in widespread use. So, for the most for the money, ask for a demonstration of the 310-AB. Check it out, and then check the price tag! Write for full specifications.



KROHN-HITE CORPORATION
580 Massachusetts Avenue • Cambridge 39, Mass.
Pioneering in Quality Electronic Instruments



PROGRAMMER'S console for the Daystrom system

grammed for a full day's studio operation.

According to TRW, a novel feature of its installation will be studio lighting preset storage and retrieval. CBS has been using a TRW computer for control of KNXT, Los Angeles, since Dec. 31, 1960.

Portable Generator Will Power Tv Sets

TOKYO—Sony and Honda Motor Co. are jointly developing a portable generator driven by a gasoline engine to supply power to Sony's micro-tv sets. Sony says it expects big demand both here and abroad because at present battery capacity severely limits portable use of its set. Prototype uses four-cycle, 15-cc engine to drive a 40-w generator. It runs five hours on one-half liter of gasoline.

NAVY BUYS DRRR

Navy will install one of Northrop Ventura's DRRR antennas (ELECTRONICS, p. 44, Jan. 11) on a Pacific Missile Range instrumentation ship now under construction, according to Northrop. The ship is designed to recover manned spacecraft.

The antenna array will consist of five concentric circular elements, 3 to 35 feet in diameter and 5 feet high. It will operate at 2 to 30 Mc. Efficiency will be close to that of a 120-foot-high tower antenna, the company says

Welded module construction



Glotrac's precision antennas point to space

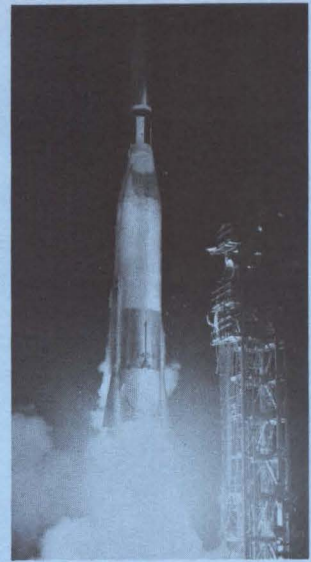

Glotrac trailer and antenna check-out

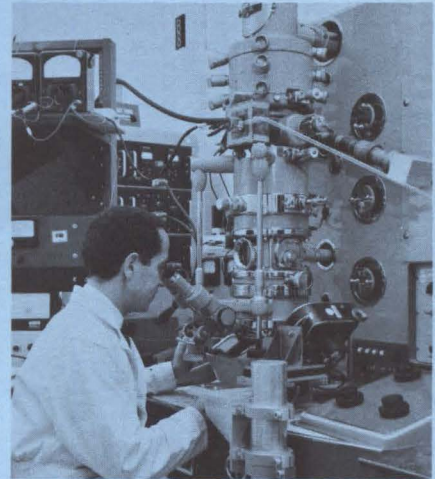

Electron microscope for epitaxy research

What exists "behind the scenes" of the world's most advanced satellite and spacecraft tracking system?

What is *Glotrac*?

Glotrac is the world's most advanced system of its kind, designed and built by General Dynamics | Astronautics in San Diego for the Air Force Missile Test Center, Cape Canaveral. Basically, *Glotrac* is a range and range rate Global Tracking Network of some 23,000 statute miles extent.

The system utilizes continuous wave techniques involving Doppler and CW phase delay principles to determine velocities accurate to better than 0.5 fps and to fix vehicle position within 100 feet. *Glotrac's* ground system consists of air-transportable equipment trailers, amplitudine-driven precision antennas and coaxial cable interconnections. The exactly positioned stations develop input for computer solutions—in real time for target acquisition—and postflight for highly precise trajectory data and orbital parameter analysis.

Among other significant achievements, an Astronautics Type CT airborne transponder has successfully transmitted data from a vehicle throughout the severe ionization period of re-entry.

What makes *Glotrac* tick?

What is the basis for the *Glotrac* system's dramatic capabilities—and the many other

highly advanced electronic programs in study, design or hardware stages at Astronautics?

The answer is—men like yourself: if you are an electronic engineer or scientist of superior abilities...if you have a special way with success in your work...if you delight in the sudden insights that result from intense involvement with your field...if you have the experienced skills that give practical form to your far-ranging ideas...if you have the drive that sees you through to crack the toughest problems...if you hunger for new challenges after the unknown becomes known to you.

If you are this kind of man, you will be interested in the extensive opportunities for important contributions and career advancement at completely space-oriented General Dynamics | Astronautics.

What are Astronautics' future programs?

Dozens of active study contracts and in-process hardware projects involve electronic engineering of a high order. To name a few: CENTAUR The top-priority NASA space vehicle designated for soft-landing instrument packages on the moon plus other im-

portant missions. NOVA Brawny booster for manned interplanetary space probes. ATLAS SLV III Standardized version of the famous NASA Mercury series and Venus fly-by launch vehicle. SCIENTIFIC PASSENGER PODS for varied research programs. COMMUNICATION SATELLITES and related equipment. FUTURE TRACKING SYSTEMS.

Consider the scope of electronic engineering activities at Astronautics. Also consider the General Dynamics Corporation, of which Astronautics is an important part. In research and development for fiscal year 1962, General Dynamics topped the list of 500 leading military prime contractors.

If you are qualified...

If you are highly qualified for one of the positions detailed on the next page—consider joining the Astronautics staff. Your reply, which will be held in complete confidence, may be made on the attached Professional Placement Inquiry form, or by writing to Mr. R. M. Smith, Chief of Professional Placement and Personnel, Mail Zone 130-90, General Dynamics | Astronautics, 5838 Kearny Villa Road, San Diego 12, California.

GD

GENERAL DYNAMICS | ASTRONAUTICS

AN EQUAL OPPORTUNITY EMPLOYER

A MESSAGE OF INTEREST TO ELECTRONIC ENGINEERS

Important positions exist in the following areas:

ADVANCED SKILLS in electronic miniaturization at Astronautics are demonstrated in *Glotrac's* Type G airborne transponder. This high-density flight article weighs a mere 5.6 pounds.

Reliability is enhanced by use of solid state elements and welded module construction throughout. Functions which can be added through the *Glotrac* transponder for tracking of the future include space communication, time and frequency multiplex, telemetry and command functions.

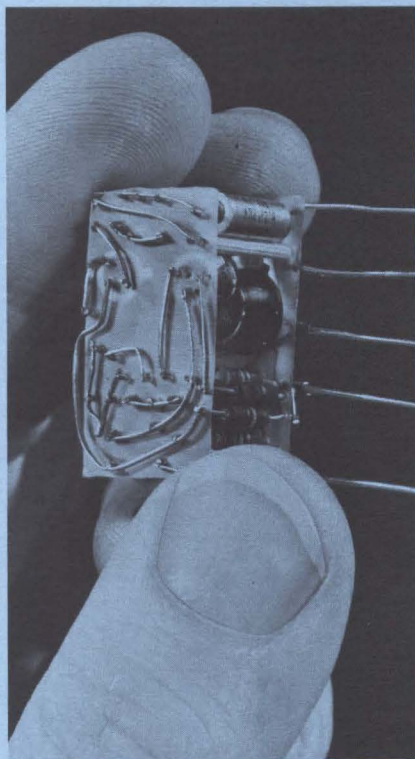

Glotrac transponder welded module

To learn more about Astronautics or to provide additional information about your qualifications — or if the Professional Placement Inquiry card has been removed — please write to Mr. R. M. Smith, Chief of Professional Placement and Personnel, Mail Zone 130-90, General Dynamics | Astronautics, 5838 Kearny Villa Road, San Diego 12, California.

ADVANCED ELECTRONIC SYSTEMS

Assignments are on such projects as giant boosters, advanced tracking systems, unmanned satellites, nuclear-propelled space vehicles, earth-to-moon logistics bus, and space stations. Experience should include advanced design work in such electronic areas as guidance, communications, telemetry, data processing systems or antenna systems. An advanced degree is required.

ELECTROMAGNETIC INTERFERENCE CONTROL

Strong design experience in communication systems required. Assignment will be to lead evaluation of designs from an interference control standpoint, as E.I.C. on missile and space systems involving individual subsystems and complex composites of electrical and electronic equipment. Must be capable of original and creative efforts. BSEE or MSEE is required.

TRACKING EQUIPMENT DESIGN

Positions are for circuit and system designers with experience in UHF, SHF, and microwave equipment. Solid state background in development of receivers; ultra-stable oscillators; high-frequency, high-powered amplifiers, and similar type circuitry desirable. Openings also exist for system designers, experienced in CW tracking equipment and related peripheral equipment, for development of hardware for ground station and space vehicle applications.

INSTRUMENTATION SYSTEMS ENGINEERING

Engineers able to analyze data requirements for various missile systems including propulsion, fluid mechanics, flight control and structures; to determine validity of requirements, and design feasibility for making measurements; and to determine the general parameters for airborne/ground instrumentation systems. Detail hardware design capability is not required, however. BS or MS in EE, physics, or AE is required, with desired experience of 3 to 5 years in instrumentation planning or testing.

Openings also exist for graduate engineers who are highly qualified in these activities:

AIRBORNE AND GROUND ELECTRICAL/ELECTRONIC LOGIC CIRCUIT DESIGN, ADVANCED SYSTEMS DESIGN, FLIGHT TEST, ENGINEERING WRITING and TEST EQUIPMENT DESIGN. Special openings for recent college graduates also are available in a wide variety of engineering areas, including the above.

RELIABILITY

Engineers with BS in EE, physics, math or ME to administer Reliability Program. Openings exist in reliability analyses, systems, data retrieval and corrective action, and parts control. Mathematicians to qualify should have knowledge of probability theory and statistics of quality control. Engineers and physicists should have 2 to 8 years of experience in design and/or environmental testing of aerospace products. Typical tasks include vendor surveillance, collection of test data from all sources and evaluation for failure and effect modes, review of product specifications and drawings for reliability requirements, writing of reliability test plans, test monitoring, and participation in design reviews.

TELEMETRY DESIGN

Engineers with ability to develop both FM and PCM telemetry systems, transmitters, antennas, signal conditioners and transducers; tasks involve detail design on signal conditioners, measuring circuits, and analog or digital circuitry; analysis and development of telemetry systems based on modulation and information theory; and evaluation of vendor-furnished transmitters and transducers. BS or MS degree in EE or ME and two or more years of experience required.

GUIDANCE and CONTROL SYSTEMS

Requirements exist in three general areas: (1) analytical area for those with experience in establishing guidance and flight control system requirements and analysis of system performance; (2) activities involving detail design and development of the autopilot, programming devices and passive tracking equipment with additional responsibility for design of associated test equipment; (3) design liaison group, responsible for assuring accuracy and reliability of the guidance system by monitor of the system-manufacturing sub-contractor, and activities to assure that delivered G.S.E. and airborne systems mate with the missile and its check-out complex.

BS degree in EE and/or physics, plus 3 to 5 years of direct experience with navigation and guidance systems design or test, are required.

GENERAL DYNAMICS

GENERAL DYNAMICS | ASTRONAUTICS

AN EQUAL OPPORTUNITY EMPLOYER

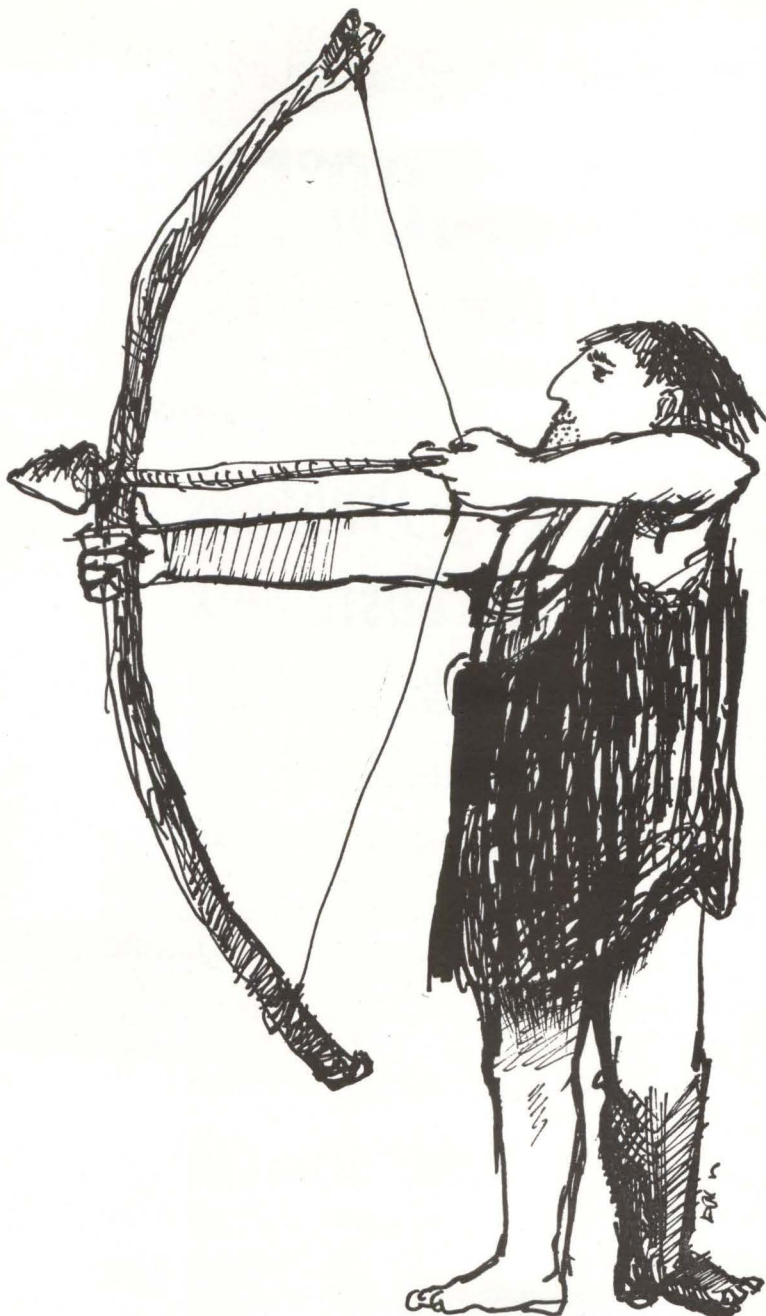

The day when the designer selected his materials all by his lonesome is past—especially in electronics. Lots of engineers, from many departments, get into the electronics buying act with the design engineer today. Production engineers, for example, feel free to bare their fangs at any specified product they feel would snafu the production line. Procurement people growl for their freedom to respecify for the sake of better prices or delivery. Service engineers, once burned by a faulty component or subassembly, are twice shy and thrice loud about its inclusion in future equipment. And management's oxen are notoriously goreable. That's what makes electronics marketers turn gray. The advertiser today must

reach the design engineer *and* everyone else in electronics engineering. He can do so either through a passel of splinter publications, or through electronics.

Well, that's the price of progress.

electronics is the weekly, contemporary engineering publication of the modern electronics industry. It integrates the interests of 57,000 engineers in all phases and functions of electronics—the people who pass on your products before they are bought. In a field abounding with free publications, these 57,000 engineers pay up to \$6 a year to subscribe to electronics. They need electronics. You need them. Advertise in electronics.



HOW TO LACE FOR

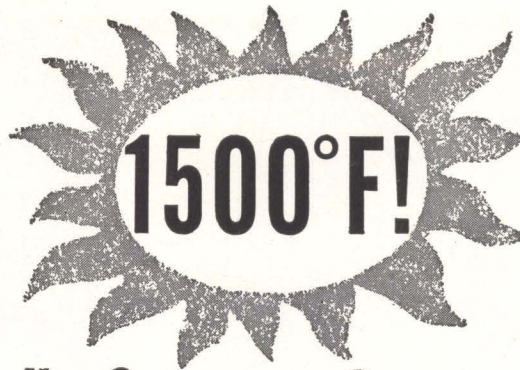

Why Gudebrod's Common Sense Approach to Lacing Problems Pays Dividends for Customers!

Recently a customer involved in the missile program came to us with a problem. He wanted a lacing tape that would be easy to use but must withstand extremely high temperatures . . . well above 1000°F!

We had to admit that we had no such tape. Our high temperature tapes such as GUDE-GLASS® have a maximum temperature range of 800°F. To solve this customer's problem, we developed GUDE-Q®, a revolutionary new lacing tape *that is essentially stable to temperatures in excess of 1500°F.*

GUDE-Q is a flat braid made from continuous length silica fibers that have been especially impregnated with a silicon finish to produce excellent handling and tying qualities. GUDE-Q lacing tape allows harnesses to be easily tied . . . knots don't slip, yet it withstands temperatures in excess of 1500°F.

Creating a new tape to meet high temperature requirements is but one of many ways in which we serve customers' needs. Whatever your lacing tape needs—civilian, military, fungus proofing, high temperature, color coding—Gudebrod's common sense approach to the problem will pay dividends for you because:

1. *Gudebrod lacing tape increases production!*
2. *Gudebrod lacing tape reduces labor costs!*
3. *Gudebrod lacing tape means minimal maintenance after installation!*
4. *Gudebrod is quality—our standards for lacing tape are more exacting than those required for compliance with MIL-T!*

Write today for our Technical Products Data Book which explains in detail the many advantages of Gudebrod lacing tape for both civilian and military use.

Address your inquiry and your lacing tape problems to:



GUDEBROD BROS. SILK CO., INC.

FOUNDED IN 1870

Electronics Division

12 SOUTH 12th STREET, PHILADELPHIA 7, PENNA.

MEETINGS AHEAD

INTERNATIONAL TELECOMMUNICATION UNION PANEL OF EXPERTS MEETING, IEEE, et al; Geneva, Switzerland, June 4-23.

RELIABILITY TRAINING CONFERENCE, IEEE-PTGR, ASQR; Bishop's Lodge, Santa Fe, N. M., June 10-14.

BIO-ENGINEERING SYMPOSIUM, ISA; Union Oil Co. Bldg., Los Angeles, June 14-16.

SUMMER GENERAL MEETING IEEE; Royal York Hotel, Toronto, Canada, June 16-21.

BROADCAST & TV RECEIVERS CONFERENCE, IEEE-PTGR; O'Hara Inn, Chicago, June 17-18.

JOINT AUTOMATIC CONTROL CONFERENCE, IEEE, ISA, et al; University of Minnesota, Minneapolis, Minn., June 19-21.

X-RAY AND ELECTRON PROBE ANALYSIS SYMPOSIUM, American Society for Testing and Materials; Chalfonte-Haddon Hall, Atlantic City, N. J., June 23-28.

IMPACT OF MICROELECTRONICS CONFERENCE, Armour Research Foundation and ELECTRONICS Magazine; Illinois Institute of Technology, Chicago, Illinois, June 26-27.

COMPUTERS & DATA PROCESSING SYMPOSIUM, University of Denver; at the University, Denver, Colo., June 26-27.

LOUDSPEAKER INDUSTRY CONFERENCE, EIA; Pick Congress Hotel, Chicago, June 27.

INFORMATION THEORY IN SCIENCE & ENGINEERING SEMINAR, Dartmouth College; at Dartmouth, Hanover, New Hampshire, July 1-12.

ADVANCED CONTROL THEORY AND APPLICATIONS, Massachusetts Institute of Technology; at MIT, Cambridge, Mass., July 8-19.

WESTERN ELECTRONIC SHOW AND CONFERENCE, WEMA, IEEE; Cow Palace, San Francisco, Calif., August 20-23.

ADVANCE REPORT

AEROSPACE ELECTRICAL/ELECTRONIC CONFERENCE, Aerospace Electrical Society; Pan Pacific and American Institute of Aeronautics and Astronautics Auditoriums, Los Angeles, Oct. 9-11. July 1 is the deadline for submitting three copies of 100 to 200-word abstracts and one reproducible copy of paper to Rudolf Steiner, AES Technical Program Chairman, Astro Reliability Corp., Sherman Oaks, Calif. Of interest are the following electrical and electronic aspects of aircraft, missiles and space system vehicles: development; testing; performance; failure analysis; environmental conditions of atmosphere; temperature; vibration; heat transfer; shock; acceleration; radiation; acoustics; radio-frequency and interference; landing and launch equipment; telemetry; tracking; guidance; range safety; fuel flow and storage; reliability considerations of systems compatibility.

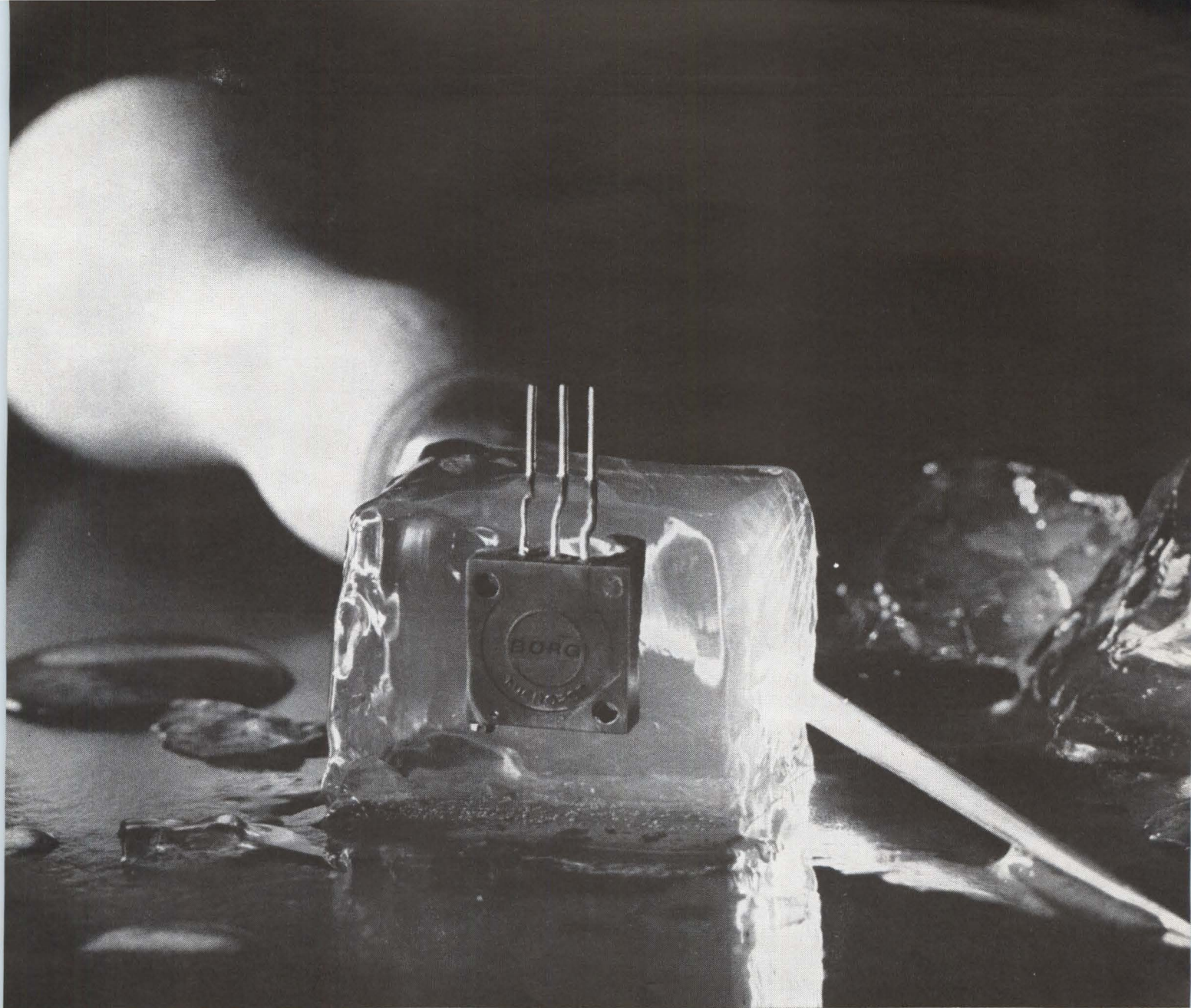

Freeze it. Wet it. Heat it. Jar it.

Here's why you can practically do anything to this new 1/2" square Micropot® trimmer:

SILVER BRAZED TERMINATIONS—no fine wire connections

POSITIVE, NO-SLIP WIPER POSITIONING—detent prevents movement even under severe shock and vibration

CLUTCH MECHANISM PREVENTS DAMAGE at end of travel

BONDABLE TEFLON LEADS assure most reliable possible sealing

SPECIAL HIGH TEMPERATURE (DU PONT ML) INSULATION between mandrel and resistance element prevents catastrophic failures

Where else can you get a 1/2" square trimmer with all these features—in your choice of terminal configuration? The subminiature Model 2900 Micropot trimmer is designed to meet all requirements of MIL-R-27208A. It is humidity-proof, dustproof, and shockproof to 100 g's. You can take it down to -65°C or heat it up to 175°C.

Now scan this trimmer's specs. Interested? Phone your nearby Borg distributor. Or drop a line to R. K. Johnson, Sales Manager.

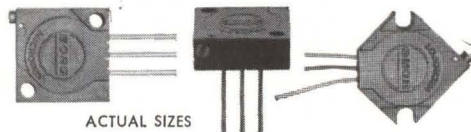

Resistance values.....10 to 100 K ohms
 Resistance tolerance..... ± 5%
 Power rating....1 watt at 70°C, 0 watt at 175°C
 Resolution of adjustment.....1.0% to 0.084%
 Mechanical adjustment.....25 turns nominal
 Temp coefficient of Pot.....30 ppm/°C nominal
 Operating temperature range..-65 to +175°C
 Humidity—proof..... MIL-R-27208A
 Mechanical stops...clutch allows contact idling



BORG EQUIPMENT

A Division of Amphenol-Borg Electronics Corporation
 Janesville, Wisconsin



no margin for error Straight down it's 12,000 feet! As these sky divers swoop together to pass this aerial baton there can be no margin for error. Less than perfect accuracy in timing could mean a mid-air collision or a complete miss. To users of electronic time delay relays, precision solid state programmers, and magnetostrictive pulse counting devices, a "miss," or error of accuracy in timing, could have far more disastrous results. That's why military and industrial users turn to TEMPO for infallible accuracy and reliability. Do you have a time problem which allows no margin for error? Let TEMPO know-how offer a **fast, efficient** and **economical** solution.

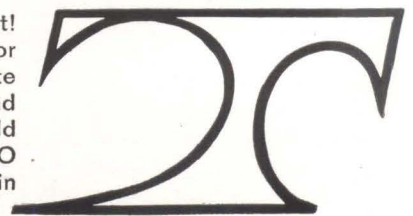

TEMPO INSTRUMENT INCORPORATED • East Bethpage Road • Plainview, L.I., N.Y., 516 MYrtle 4-4400

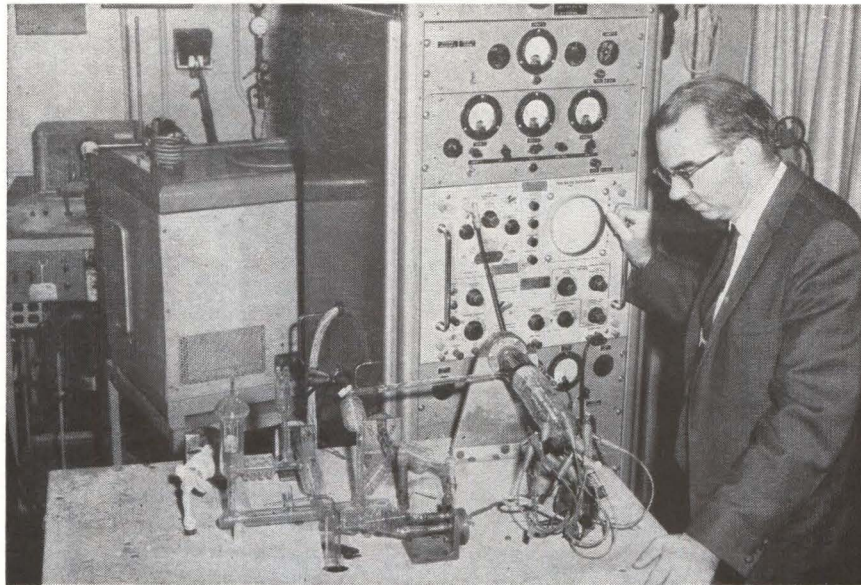

SECONDARY emission studies are being conducted in this laboratory lash-up

ARE HOT CATHODES ON THE WAY OUT?

Research into new types of cold-cathode materials and structures is slowly overcoming difficulties. Characteristics of the various types may eventually allow elimination of hot cathodes in most devices

By W. M. FEIST and G. WADE, Raytheon Co. Research Div., Burlington, Mass.

NONTHERMIONIC cathodes, when fully developed, will allow new types of electronic devices not possible now with hot or thermionic cathodes. Cold cathodes of various types will provide high current density, low power consumption, low beam noise, and instant starting. Photoemitter cathodes, for example, may provide another technique for generating millimeter wavelengths; field emitter cathodes have already been used to obtain high speed x-ray pictures.

CATHODE PRINCIPLE—Electrons are commonly supplied from substances containing large numbers of bound electrons available for emission. Effects used to give bound electrons sufficient energy for ejection from a cathode substance include: thermionic emission, in which phonons or thermal lattice vibrations collide with the bound electrons;

photoelectric emission, in which photons from incoming light collide with the bound electrons; secondary emission, in which energetic electrons coming from the outside or created within the substance collide with the bound electrons; and field emission, in which strong forces are exerted upon the bound electrons by a large external electric field.

Free electrons can also be obtained from plasmas, which exist in both gases and solids. Emission from a plasma can be obtained by diffusion, an effect brought about by a gradient in the electron density.

Most devices today use thermionic cathodes, but these cathodes can never be completely satisfactory as electron sources. Obtainable emission density is basically determined by work-function ϕ and cathode temperature T , according to Richardson's equation $i = AT^2 e^{-\phi/kT}$, where A is 120 amp/cm²K² (K = degrees Kelvin) and k is Boltzmann's constant. For high

LATEST BOX SCORE IN COLD-CATHODE PROGRESS

Cathode	Present Typical Current Densities	Typical Materials or Structure	Present Limitations	Present Applications
1. Field Emitter	10 ⁷ amps/cm ² d-c 10 ⁸ amp/cm ² pulsed (from small points)	W	Severe vacuum requirements, High electric field requirements Large energy spread	High speed x-ray equipment
2. Photo Emitter	10 ⁻³ amp/cm ² d-c 1 amp/cm ² pulsed	C ₈ Sb, Bi-Ag-O-Cs	Efficient cathodes exist only for very limited frequencies	Photo detection Photo mixing Solar cells
3. Secondary Emitter	10 ⁻¹ amp/cm ² d-c 10 ² amp/cm ² pulsed	Pt, W-ThO ₂ , MgO, BeO	Large energy spread. Heat dissipation and charging problems	Current amplifiers, Microwave tubes Image and information storage
4. Plasma Emitter	10 to 10 ² amp/cm ² d-c	Hg, Arc discharge	Differential pressure requirements. Large energy spread. Inefficiency as vacuum tube cathode	Heat source
5. Mg O-type Emitter	10 ⁻³ amp/cm ² d-c 10 ⁻¹ amp/cm ² pulsed	Ni-NiO-MgO	Slow time response. Starting process necessary. Strong response to anode voltage	—
6. P-N Junction Emitter	10 ⁻⁷ to 10 ⁻⁵ amp/cm ² d-c	Si, SiC	Inefficiency	—
7. Tunnel Emitter	10 ⁻³ amp/cm ² d-c 10 amp/cm ² pulsed	Al-Al ₂ O ₃ -Au, Be-BeO-Au	Low efficiency Poor dc-stability	—

^a Cathode efficiency = (emitted current)/(power supplied to cathode)

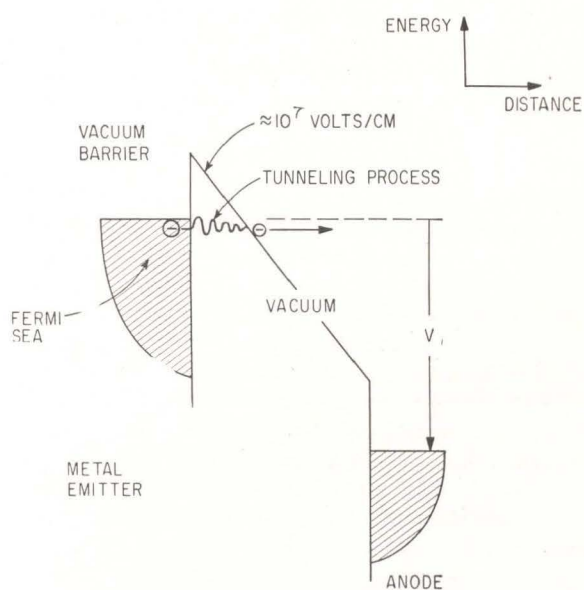

SIMPLIFIED REPRESENTATION OF THE FIELD EMISSION PROCESS

IN FIELD-EMITTER cathode, strong electric fields pull electrons from cathode surface—Fig. 1

current density at high efficiency, the work function should be low. Heating requires that the cathode be made of refractory material to prevent evaporation at high temperatures. The emitting surface should be sufficiently conductive to avoid an excessive internal voltage drop. These requirements are met ordinarily by coating a refractory metal, like tungsten, with an oxide or with a material of low work function. The cathode surface is maintained in dynamic equilibrium with respect to temperature and field evaporation, decomposition by heat, ion and electron bombardment, diffusion within the cathode, and various chemical reactions. Current density from thermionic cathodes is normally limited to about 100 amp/cm². This amount of current can be drawn only for microseconds^{1, 2} but longer periods are desirable in many applications.

A small emitting area allows smaller device size, facilitates focusing and reduces noise resulting from position fluctuation. Noise can sometimes be reduced merely by allowing the beam to expand. For good resolution in electron microscopy and in display and storage, a point source emitter is desirable. High current density from a small emitting area is par-

Projected Applications	Typical Cathode Efficiency ^a	State of Art
Microwave tubes mm-wave generation Mixing Harmonic generation Rectification	Very high	Research and development.
Mm-wave generation Low noise amplification	10 ⁻¹ amp/watt	Research and development.
Extension of present applications	10 ⁻¹ amp/watt	Research and development.
Ultrahigh frequency tubes	10 ⁻³ amp/watt	Early research and development.
Amplifier tubes Display and storage tubes	10 ⁻² amp/watt	Research
—	10 ⁻⁶ to 10 ⁻⁴ amp/watt	Early research
Direct replacement of thermionic cathodes; modulation, mixing, low noise amplification	10 ⁻³ amp/watt	Early research

ticularly desirable at short wavelengths, since the external circuits themselves are small.

Thermionic cathodes are limited with respect to beam noise reduction, which affects device sensitivity or resolution. Thermionically emitted electrons follow a so-called half-Maxwellian energy distribution and have a large spread in energy. Noisiness can be reduced by controlling conditions just beyond the cathode surface, but the technique is complicated.

The inertia to temperature change of thermionic cathodes precludes saving heat power in intermittent operation, and also prevents current control by heat pulsing. While the current can be controlled by electric fields in the space charge region, the velocity of the electrons is low here and limits frequency response. The high temperatures of thermionic cathodes also require insulation.

Some nonthermionic cathodes now being researched are listed in the table. But the realization of practical nonthermionic cathodes is difficult.

FIELD EMITTERS—Electric fields of the order of 10⁶ volts per centimeter and higher can reduce the work function of an unheated metal or semiconductor

low enough that electrons can be emitted into a vacuum by quantum-mechanical tunneling, Fig. 1. For metals, the density of current emission is given by the Fowler-Nordheim equation: $i = BE^2 e^{-\beta/E}$, where E is the electric field at the surface, and B and β are constants of the work function.

High electric fields can be produced with moderate voltage for a sharp point. From such points, greater than 10⁷ amp/cm² is possible with continuous operation and greater than 10⁸ amp/cm² pulsed. When field emitters are heated thermionic and field emission act together⁴, in a process called T-F emission; T-F emission applied to x-ray tubes has given up to 10⁸ amp/cm². Field emission can be used also with photoemission, secondary emission, etc.

A major difficulty with field emitters is instability, since current density is a sensitive function of applied field and work function and both can change unexpectedly in an operating device. The sharp points change because of heating, particle bombardment, chemical reaction and evaporation, and affect both the acting field and the work function. Pressure as low as 10⁻¹² mm Hg can prevent such changes but is difficult to realize in practice. However, using sealed off alumina-silicate glass envelopes, cold-cathode field-emission diodes have operated stably d-c for over 15,000 hours at 300 watts average power and at cathode current densities of the order of 10⁷ amp/cm². At more conventional vacuums, stability is provided by periodically and briefly heating the emitter to smooth and clean its surface. Life for tungsten emitters is presently about 500 hours. Research is aimed at reducing field requirements and improving stability.

Over 90 per cent of the beam has been focused electrically into a few millimeters and 0.06 per cent of the cathode emission of a crt was focused to give a 2000 line/inch raster at a screen current of 0.2 μ a. Magnetically, the entire current can be focused to 0.2 mm diameter with a field of 7,000 oersteds.

Noise temperature, in terms of energy spread, is approximately three times that of low temperature oxide cathodes. But the thermionic cathode norm-

WILL COLD CATHODES GET HOT?

One of the most welcome features of the transistor and other semiconductor devices was elimination of the thermionic cathode. This feature of the electron tube was undesirable because of the thermal design problems it created and because it was a frequent cause of device failure.

But no semiconductor device, even field-effect transistors, ever achieved the isolation between input and output afforded by the vacuum tube.

Maybe the cold cathode tube can let the designer have his cake and eat it too. This article points out that research on cold cathodes is proceeding along at least seven different lines.

And the Russians are showing a high interest in cold cathodes too

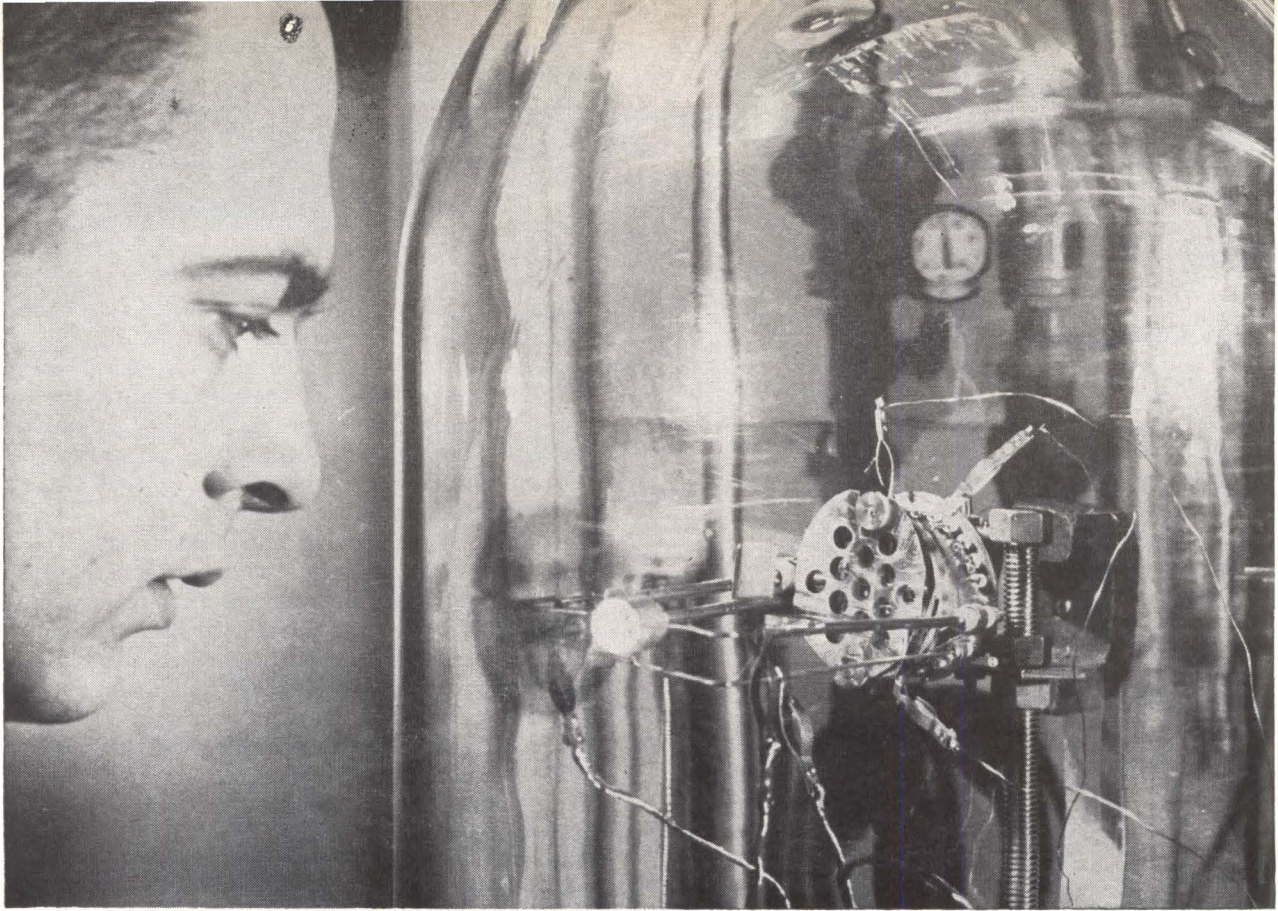

TUNNEL cathodes are being fabricated in ultrahigh vacuum

ally requires beam area compression, while with field emission beam expansion can be allowed. Thus noise temperature for transverse electron travel can be less using field emission.

In addition to high current density, field emitters have strong nonlinearity between applied field and emitted current, instant time response, and high efficiency. In a new high-speed x-ray tube developed by the Field Emission Corp. of McMinnville, Oregon, a high-energy electron beam is pulsed on for a fraction of a microsecond to produce an intense burst of x-rays. Tube uses include stop-action radiography

and radiation effect studies at 10^9 rad/sec.

The high current densities of field emission are attractive at extremely high frequencies for amplifiers, oscillators, mixers, harmonic generators, and rectifiers; Field Emission Corp. has experimented with frequency quadrupling up to 8 mm, but practical devices need more development. ^{3, 5, 6, 7}

PHOTOEMITTERS — Present photocathodes are sensitive only to frequencies in the near infrared and higher. Some present cathodes have⁸ yields close to 0.5 electron per incident photon.

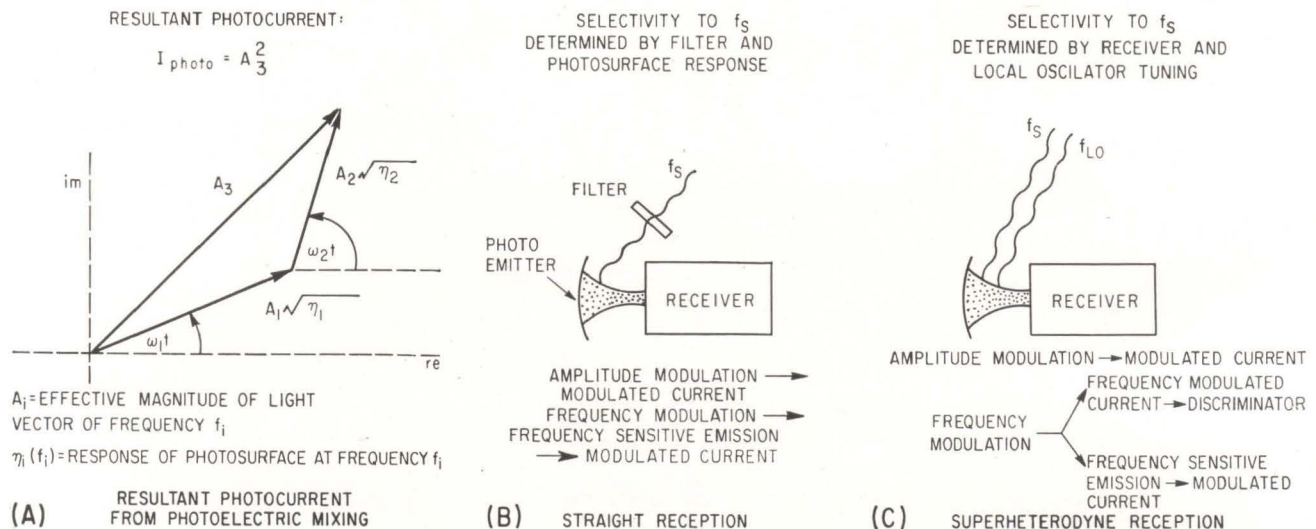

PRINCIPLES of photoelectric mixing (A), examples of modulation detection (B) and (C) by interaction with the electrons, and Siegman's frequency-modulation detector (D). These techniques may provide a way to generate submillimeter

Photoemission is a nonlinear process and can be used in detecting modulation on a light beam⁹ (See Fig. 2). When light falls upon a photoemitter, the density of the emitted stream varies with the modulation. In one photoemission detection scheme, density-modulated current is fed into the slow-wave circuit of a traveling-wave tube to amplify and extract the modulation. The frequency limit for this type of detection may be as high as several hundred Gc¹⁰.

The nonlinearity also holds promise for mixing two laser beams, separated by a microwave or millimeter-wave frequency, to obtain a density-modulated beam at the difference frequency. The modulation can then be amplified and extracted, offering possibilities for generating millimeter and even submillimeter-waves.

The photoemitter may also produce a low-noise electron beam for microwave amplifiers.¹¹ Theoretically, a beam from a photoemitter can have a small velocity spread and therefore low noise. According to the Einstein relationship for the maximum energy of emitted electrons, $E_{max} = h\nu - \psi$, where ψ = the photoelectric work function, h = Planck's constant, and ν = the frequency of the light.

The quantity E_{max} can be small if the light frequency is close to the threshold frequency ψ/h of the photocathode response. Calculations indicate sufficient photoemitter current to drive a microwave tube even when E_{max} is small enough to give low beam noise.

SECONDARY EMITTERS—A secondary emitter emits electrons when bombarded by other electrons or ions, with more electrons emitted than are used in the bombardment.¹² Hence the current density and current variations of a bombarding beam can be amplified, with large amplification possible

While many of the details of secondary emission are unknown, practical devices have been developed. One limitation is the large velocity spread in the emitted electrons and hence an inherent noisiness in the emitted beam.

An application of secondary emitter amplification is

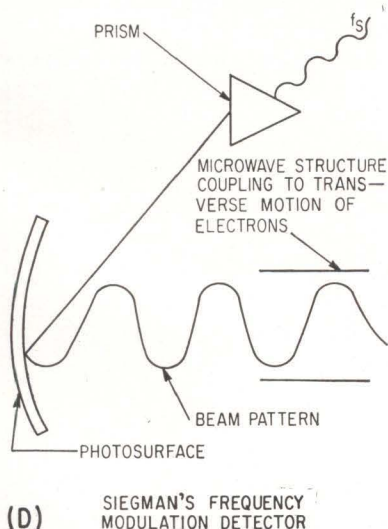

longitudinal motion of photoemitted waves—Fig. 2

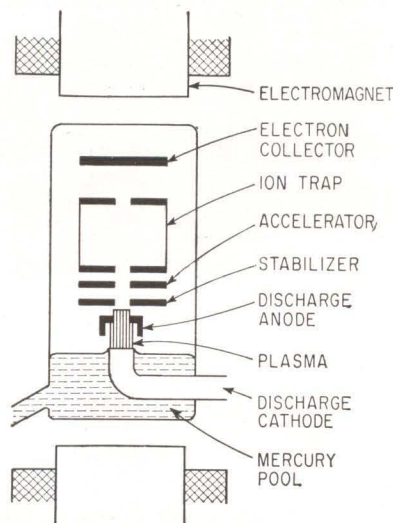

PLASMA cathodes, as suggested by K. G. Hernquist—Fig. 3

the photomultiplier phototube whose operation has been extended recently to microwave frequencies.¹³ Another application is the self-sustained emission in magnetrons and amplitrons. In these tubes, some electrons are used to bombard the cathode and produce further secondary emission. Such tubes do not require external heating once emission is started by a heating or microwave pulse.

PLASMA ELECTRON SOURCES—In this type of emission, the electrons come from a gas rather than a solid (See Fig. 3). Plasma sources can produce current densities much higher than thermionic cathodes can.¹⁴ But the apparatus for producing the discharge is cumbersome and the extraction of electrons into the vacuum is difficult. In addition, the emission tends to be inefficient, unstable and noisy.

While plasma cathodes are difficult for small devices, they have already been used in a heat source developed by Alloyd Electronics Co., Cambridge, Mass., for melting, annealing and heat treating metals by electron bombardment. After initial plasma activation by r-f, positive ions from the discharge region bombard a cathode and heat it until thermionic emission takes place. The thermionically emitted electrons pass through the plasma, releasing further electrons by ionization, and positive ions to bombard the cathode. This operation is self-sustained. A present heat source delivers 30 Kw and can melt 200 lb. of stainless steel per hour.

MgO-TYPE EMITTERS—Sustained emission from MgO and other metal oxides was obtained about a decade ago. An MgO-type emitter usually consists of a nickel sleeve coated with a metal oxide several tens of microns thick,¹⁵ (See Fig. 4).

In operation, an initial surface charge is produced by the incidence of ultraviolet light, radioactive radiation or bombarding electrons. This starts the emission, which continues after the radiation is turned off. A recent theory of operation presumes that an electron avalanche is produced by a breakdown in the metal-oxide layer under the influence of

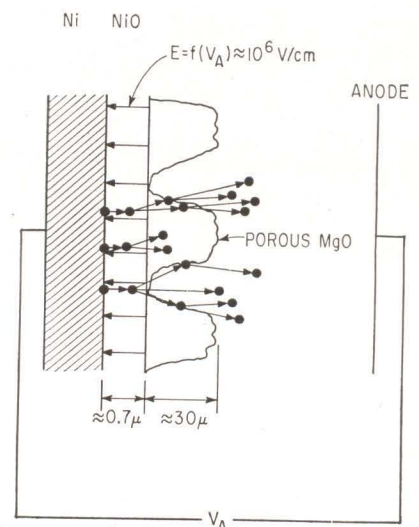

ELECTRONS are multiplied in MgO layer and some escape—Fig. 4

the strong electric fields from the surface charge. The avalanching electrons may be emitted directly or may produce secondary emission from the MgO layer before reaching the vacuum. A primary research goal is a better understanding of the process.

Current densities achievable from MgO-type emitters are comparable with those from thermionic cathodes. Major shortcomings of this type of emitter include: a large energy spread in emitted electrons (several tens of electron volts) leading to high noise and poor beam resolution; a drop of about 200 volts across the metal-oxide layer, making the cathode inefficient; the necessity for a starting process.

The time constant for starting causes problems in rectifier operation even at low frequencies.

Further development depends on a better understanding of the process, and research objectives include stability improvement, noise reduction, and self-starting.¹⁵

P-N JUNCTION EMITTERS—The *n*-type material in the back-biased *p-n* junction diode of Fig. 5 is some tens of Angstroms thick, with the outer surface the cathode surface. The bias voltage can excite hot electrons into the *n*-type material, with most of these electrons originating in the valence band of the *p*-type material and transposed by tunneling or avalanche breakdown. Some of the transposed electrons arrive in the *n*-type material with energies higher than the vacuum level. The electrons then drift and diffuse through the *n*-type material, and some are emitted into the vacuum,¹⁷ in an operation similar to the tunnel cathode.

But the emitter has serious limitations. The rate at which energy is lost as a hot electron travels in the *n*-type material is high and an electron, after tunneling at an energy level above the vacuum level, may still not be able to escape because of losing energy before it reaches the surface. The *n*-type layer can only be so thin before the properties of the junction are affected, and the minimum possible thickness is too great to permit many of hot electrons to escape. The experimental data thus far reported involve current densities of about 0.1 microamp/cm², too low to be useful.

The velocity spread of the emitted current gives

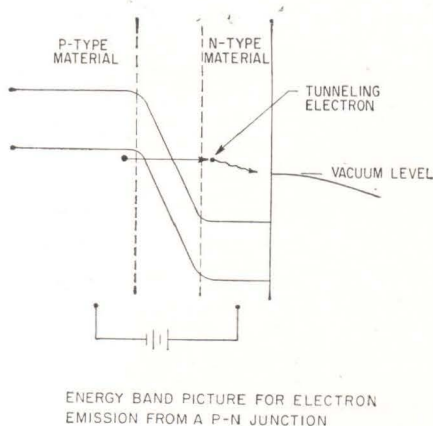

P-N JUNCTION cathode must overcome severe problems to become practical—Fig. 5

noise temperatures of about 6,000 K.

The hot electrons that are not emitted flow through the battery and constitute a circulating current, which produces a lateral voltage drop across the cathode surface. Emission is critically dependent upon surface voltage, thus serious nonuniformity in emission results.

TUNNEL CATHODES—This type cathode promises more desirable features than the other types, including high current densities, low temperature operation, low-noise beams and instant starting. High current density and low noise beams would not be obtained simultaneously, however. In addition, space charge limited operation should be possible.

The tunnel cathode is a metal-insulator-metal sandwich, as illustrated in Fig. 6. Electrons tunnel from the metal substrate and appear in the metal film as hot electrons. Some of the hot electrons have sufficient energy to pass over the cathode surface barrier into the vacuum.¹⁸ In the figure, a temperature of 0 K is assumed for simplicity.

Electrons in the metal substrate occupy energy levels up to fermi level F_1 ; those in the metal film, up to fermi level F_2 . F_2 has been shifted down with respect to F_1 by the battery voltage, which appears across the insulator. Since the insulator is a thin film, electrons can tunnel through it into the metal film. The battery voltage exceeds the height of the vacuum barrier and some of the tunneling electrons arrive with energies higher than the vacuum level. If the mean free path for the hot electrons is large enough compared to the thickness of the metal film, emission into the vacuum can occur. Electrons arriving at the cathode surface with energies lower than the vacuum level eventually fall to below F_2 and are conducted away through the battery, to constitute a circulating current.

Energy spread δ of the emitted electrons can be controlled by adjusting the battery voltage. Beam noise is critically dependent upon δ , and noise temperature is $T_n = 2730\delta$. The equation actually applies only when δ is small and when the cathode is at absolute zero. For a finite temperature, the velocity spread and hence beam noise temperature will be above actual cathode temperature.

For $T_n = 30K$, and $\delta = 0.01$ eV, only about one per-

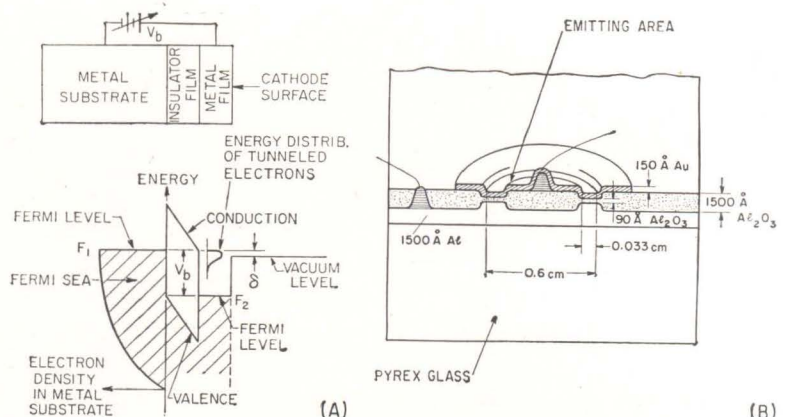

ENERGY relations (A) and one type of construction (B) for tunnel cathodes—Fig. 6

cent of the tunneling electrons are emitted into the vacuum¹⁰ and the remainder becomes the circulating current. For the same conditions, a beam current of 50 μ a was computed for a cathode 20 mils in diameter, enough to operate a low-noise twt.

For a twt beam with a noise temperature of 30K, circuit losses must be small or Johnson noise will be greater than beam noise. But losses can be reduced by cooling the circuit.

Cooling can also provide superconduction in the metal film, thus eliminating the lateral voltage drop due to circulating current; even a small lateral voltage drop would cause nonuniform emission.

Where low noise is not required, high current densities appear possible, giving a circulating current small compared to emitted current.

Problems of practical tunnel cathodes include materials and a detailed knowledge concerning their energy structure. Second, better control of the tunnel process is needed. In the experimental cathodes thus far constructed, zener tunneling—in addition to the desired quantum mechanical tunneling—probably occurs from the insulator valence band into the insulator conduction band or directly into the metal. Any tunneling into the insulator conduction band leads to inelastic scattering of the electrons passing through and adds to the circulating current.

Uniformly smooth surfaces and uniform properties over the cathode area are also necessary and the cathode films must be free of pinholes. Thicknesses must be maintained to close tolerance. For low-noise emission, the work function over the emitting surface must be uniform or the useful emission area will be small.

In spite of the difficulties, tunnel cathodes offer inherent advantages, and experimental results are encouraging. Densities to 10 amp/cm²—pulsed, to avoid thermal breakdown—have been reported²⁰; densities for d-c operation are several orders of magnitude lower. In experiments to now, emitted current has been only a small fraction of the total circulating current.

CONCLUSION—Work on cold cathodes is partly aimed at developing electron sources that eliminate

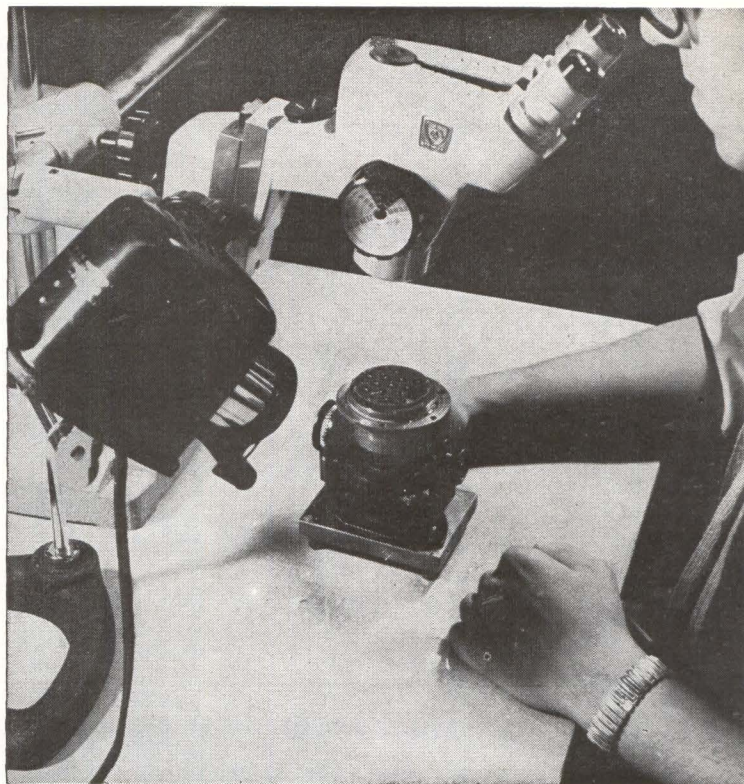

INSPECTING a tunnel cathode

inherent shortcomings of thermionic cathodes, which include limited current density, high power consumption, high temperature operation, high beam noise, and long starting time. In addition, cold cathodes are of interest for their nonlinear characteristics. Potential new applications exist in millimeter wave generation and amplification, low-noise amplification, high beam resolution, high cathode efficiency, fast starting, mixing, rectification and harmonic generation. At present, the performance of cold cathode leaves much to be desired, and none have replaced the thermionic cathode in any important way. Nevertheless, a number of unique devices have already been built.

The authors wish to acknowledge the assistance of Dr. W. P. Dyke in preparing this article.

REFERENCES

1. G. Herrman & S. Wager, "The Oxide Coated Cathode", vol. II, Chapman & Hall Ltd., London 1951.
2. L. S. Nergaard, "Thermionic Emitters", Proc. of the 4th Ntl. Conference on Tube Techniques, p. 197, Sept. 1958, N. Y. University Press 1959.
3. W. P. Dyke & F. M. Charbonnier, "Recent Progress in Field Emission", Paper presented at the AIEE Winter General Meeting Jan. 28-Feb. 2, 1962, New York.
4. M. I. Yelinson, F. F. Dobryakova, V. F. Krapivin, Z. A. Malina, & A. A. Yasnopol'skaya, On the Theorie of Field Emission and Thermionic Field Emission of Metals and Semiconductors, *Radio Engineering and Electron Physics*, No. 8, p. 1191, Aug. 1961.
5. E. G. Brock, F. M. Charbonnier, J. D. Sleeth, and W. P. Dyke, "The RF Modulated Field Emission Cathode as a Harmonic Generator", Proc. of the 4th Ntl. Conference on Tube Techniques, p. 125, Sept. 1958, N. Y. University Press, 1959.
6. J. P. Barbour, F. M. Charbonnier, L. F. Garrett & P. Dyke, "On Application of Field Emission to a Two-Cavity Microwave Amplifier", Proc. of the 4th Ntl. Conference on Tube Techniques, p. 133, Sept. 1958, N. Y. Univ. Press 1959.
7. K. D. Froome, "Proposed Harmonic Generator or Mixer for Optical Frequencies", *Nature* 192, p. 859, 1961.
8. W. E. Spicer, Photoemission and Related Properties of the Alkali-Antimonides, *J. Appl. Phys.*, 31, No. 12, p. 2077, Dec. 1960.
9. A. T. Forrester, Photoelectric Mixing as a Spectroscopic Tool, *J. Opt. Soc.*, 51, No. 3, March 1961.
10. A. E. Siegman, "Microwave Phototubes and Demodula-

tors", NEREM Record 1961, p. 118.

11. W. Feist, "New Applications of Photocathodes and Associated Problems", Paper Presented at the AIEE Winter General Meeting, Jan. 28-Feb. 2, 1962, New York.

12. A. J. Dekker, "Solid State Physics", Prentice Hall Inc., 1960.

13. O. L. Graddy, and D. F. Holshouser, High-Grain Dynamic Microwave Photomultiplier, *Proc IRE*, 50, No. 2, p. 207, Feb. 1962.

14. K. G. Hernquist, High Voltage Electron Extraction from an Arc Discharge Plasma, *RCA Review*, p. 170, June 1960.

15. A. M. Skellet, B. G. Firth, D. W. Mayer, "Some Properties of the MgO Primary Electron Emitter", Proc. of the 4th Ntl. Conference on Tube Techniques, September 1958, p. 138, N. Y. Univ. Press 1959.

16. D. Dobischek, "The Magnesium Oxide Type Cold Cathode, Present Status and Aspects of Further Advancement", Paper presented at the AIEE Winter General Meeting, Jan. 28-Feb. 2, 1962, New York.

17. J. L. Moll, N. I. Meyer, and D. J. Bartelink, Hot Electron Emission from Silicon p-n Junctions Parallel to the Surface, *Phys Rev Letters*, 7, No. 3, p. 87, Aug. 1, 1961.

18. C. A. Mead, Operation of Tunnel Emissive Devices, *J Appl Phys*, 32, No. 4, p. 646, April 1961.

19. G. Wade, R. Briggs, and L. Lesensky, Low Noise Beams from Tunnel Cathodes, *J Appl Phys*, 33, No. 3, p. 836, March 1962.

20. C. E. Horton & C. E. Mead, "Tunnel Emission", Paper presented at the AIEE Winter General Meeting, Jan. 28-Feb. 2, 1962, New York.

INDUCTORS NO PROBLEM

New Thin-Film Amplifier

By RICHARD LESLIE and THOMAS TOWNSEND, AIL Division, Cutler-Hammer, Inc. Deer Park, N. Y.

WHAT ABOUT THOSE BIG INDUCTORS?

Don't use them. That's how the authors solved the problem of making a thin-film amplifier. In addition, they solved a couple of other problems inherent with this type of device. They won't say what the amplifier is used for, except that it is in a classified space program and is working well

LOGARITHMIC i-f amplifiers, of tuned-stage design, do not lend themselves to microminiaturization. Inductors required are not compatible with size reductions possible with solid-circuit or thin-film techniques. A 60-mc log i-f amplifier with untuned stages has been specifically designed for microcircuit fabrication. Of modular construction, the amplifier occupies only 4 cubic inches, which is a reduction in volume of 20 to 1 over previous log i-f amplifiers.

Successive-detection log i-f am-

plifiers derive the log characteristic from the sum of the individual responses of each amplifier stage. These amplifiers have been designed using tuned common-emitter or common-base amplifiers. But there is a major problem of miniaturizing inductors. Also, a tedious alignment procedure is required because of reciprocal interaction of tuning and logging adjustments.

Investigation showed that RC-coupled amplifiers provide one solution to these problems. Untuned stages at 60 Mc are possible using

one of the higher performance vhf planar transistors. To minimize the interaction of the i-f stages when driving a common video load, one video stage is included with each i-f amplifier.

The log i-f stage is shown in Fig. 1. Under small-signal conditions, video section Q_2 can be considered as a small shunt conductance. Its presence has only a second-order effect on the operation of i-f section Q_1 . In this case, Q_1 acts as a linear r-c amplifier. Low-frequency cutoff is determined by the coupling capacitor and by the bypass circuits in the emitter. The upper-frequency cutoff is a function of the load resistance and the stray capacitances in the circuit. With the values shown, the i-f bandwidth extends from 20 Mc to 120 Mc (Fig. 2). Gain is about 10 db for good log operation.

As signal amplitude increases, rectification occurs in the emitter-base diode of Q_1 , causing the diode current and the emitter voltage of Q_1 to increase.

Since the base of Q_2 is held fixed, the collector current of Q_2 decreases. This action observed across R_L produces the sloped portion of the video transfer characteristic. The low-pass section between the emitters of Q_1 and Q_2 prevents the appearance of i-f at the emitter of Q_2 . As the signal level increases further, transistor Q_2 cuts off completely so that any further increase in input-signal level does not appear in the video output. The power

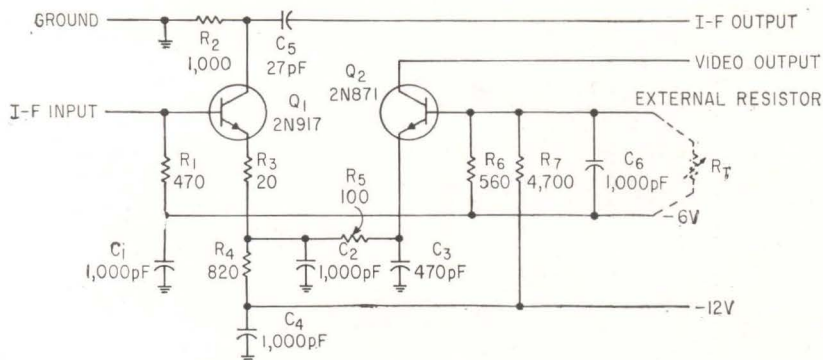

SINGLE log i-f module—Fig. 1

*Solving the problem
of inductor size in a
thin-film amplifier design
resulted in other
plus features*

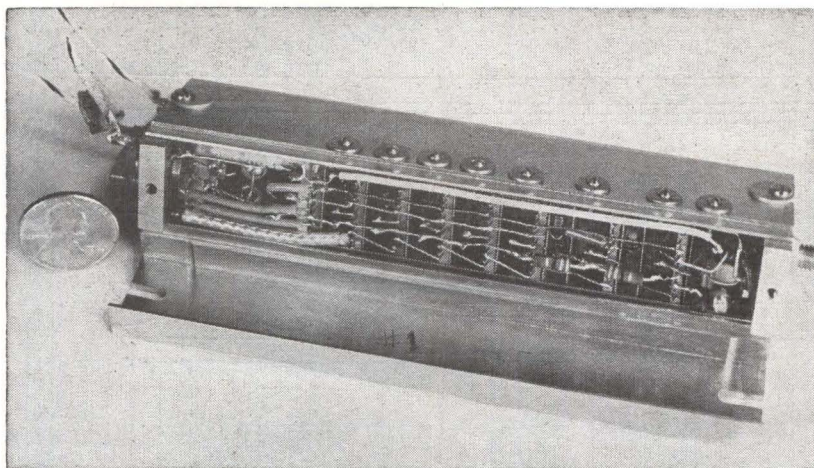

COMPLETE log i-f amplifier showing module construction and relative size compared with a penny

range over which log action takes place is 10 db. By properly selecting the bias point, Q_2 can be made to cut off before the i-f output power of Q_1 saturates.

A thin-film technique of fabrication was chosen because of the design flexibility allowed. For a 0.5 by 0.5 inch wafer, the normal limits are: Resistors less than 100 kilohms and greater than 10 ohms; capacitors no greater than 1,000 pf; ratio of resistors within a module less than 1,000; and resistor tolerances greater than 5 percent. For unusual applications, the limits can be extended slightly at a greater cost.

FABRICATION—In thin-film circuit fabrication, Fig. 3, a substrate made of either glass or fired alumina ceramic is placed in a vacuum chamber. A mask containing the desired circuit pattern is interposed between the substrate and the material to be deposited, nichrome for resistors, beryllium copper for conductors, and silicon monoxide for dielectrics, is heated in a crucible. Vapor is driven off in all directions within the vacuum chamber. The evaporating material passes through the holes in the mask and condenses on the substrate. Several masks and deposition cycles are required to produce the finished circuit containing resistors and conductors. During deposition, the substrate is heated to provide a permanent molecular bond between the materials. Deposited silicon monoxide capacitors were not used in this amplifier because of a number of

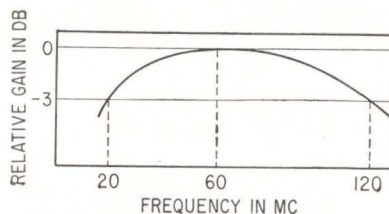

GAIN characteristic of a single log i-f stage—Fig. 2

associated problems—primarily dielectric breakdown due to minute pin holes. Standard techniques for eliminating pin holes result in too low an insulation resistance.

After the material has been deposited and removed from the vacuum chamber, chip transistors and capacitors are bonded to the substrate. These components are soldered to the appropriate deposited elements.

LAYOUT—After careful study, the complete layout of the log i-f stage including transistors was devised, Fig. 4. Environmental and electrical testing of this circuit shows that i-f circuit performance is not degraded when converting from conventional components to thin-film circuits. In many instances, circuit operation can be enhanced by microminiaturization because of the lowering of series lead inductances and stray shunt capacitances. The performance results for the thin-film stage are identical to those shown in Fig. 2 for the conventional stage.

After determining feasibility of the basic log stage, the require-

ments of the complete amplifier were considered. In general, for the successive-detection amplifier, the accuracy is limited to either input dynamic range divided by 100, or 0.5 db, whichever is greater. The number of stages, N , required to achieve this accuracy is

$$N = \frac{\text{Input Dynamic Range (db)}}{\text{Stage Gain (db)}} + 1$$

For this application, the input dynamic range can be considered to extend from -10 dbm to -70 dbm so that the maximum accuracy is 0.6 db, and $N \geq 7$. Choosing seven stages, a translation amplifier with a gain of 8 to 10 db is necessary to

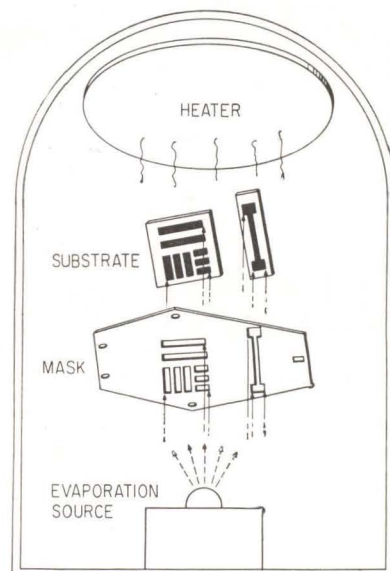

FABRICATION of thin-film circuits is performed using a vacuum evaporation system—Fig. 3

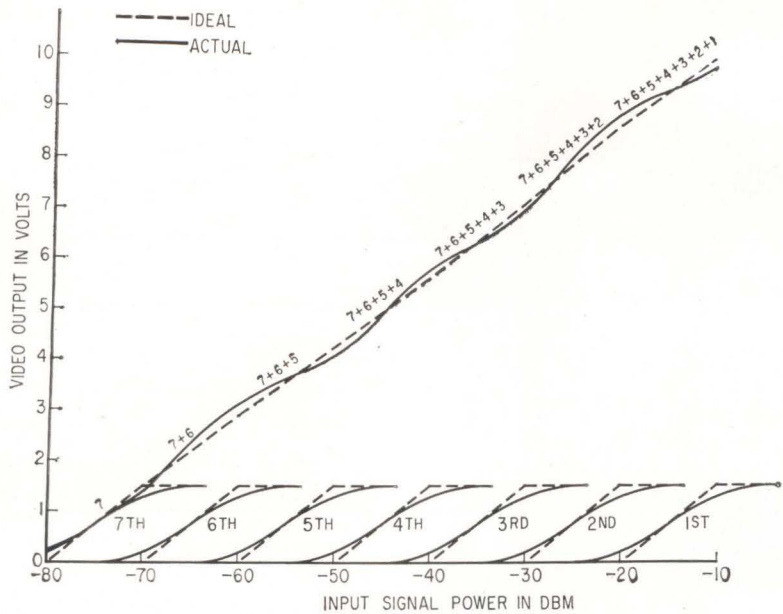

OVERALL PERFORMANCE characteristics of the complete seven-stage amplifier—Fig. 6

account gross deviations from the ideal curve due to the limited power range over which each stage adds to the overall curve. Other factors contributing to the inaccuracy cannot be remedied by using additional stages.

PROBLEMS—Size reduction introduced a number of problems. The greatest was that of stability. Because of the large gain of about 18 db per linear inch, oscillations were a constant problem. These oscillations can vary from 5 Mc (due to improper power-supply isolation) to 70 Mc (when interstage shielding is inadequate or poorly grounded).

By using toroidal choke power decoupling between the translation amplifier and the first log i-f, and between the first and second log i-f's, the low-frequency oscillation can be eliminated. Toroids are desirable since much of the field is contained within the iron core. Careful stage shielding and grounding can prevent feedback oscillations due to the proximity of the stages. However, it is necessary to maintain a center-to-center stage spacing of about 0.3 inch for the shielding to be successful.

Alignment of the stages to produce the overall log response can be accomplished by either of two meth-

ods. The first and simplest starts with the individual stages. As a part of the module test, the value of R_T (Fig. 1) that produces a known video stage current (I_{vo}) is determined. In this amplifier, it is chosen as 1.5 ma, which is a compromise between the size of R_L and the change in i-f stage current as detection takes place. With small initial values of I_{vo} , R_L must be large to produce the required video output voltage. Combined with the parallel output capacity of the seven stages, too large an R_L will limit the high-frequency video response. On the other hand, if I_{vo} is too large, the variation of i-f emitter current (I_{ie}) is too large over the detection range, thereby affecting the i-f gain during detection.

After the modules have been assembled in a complete amplifier, the nearest fixed resistor to the required value of R_T is added to each stage, and R_L chosen to be equal to V/I_{vo} , where V is the required maximum video output voltage. Experimental results show that an accuracy of ± 200 mv with respect to the ideal curve can be obtained in this manner.

For greater accuracy, potentiometers can be substituted for the fixed resistors. The potentiometers of the subminiature square type can be inserted in the interstage space

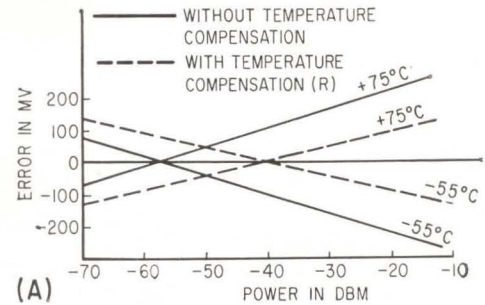

(A)

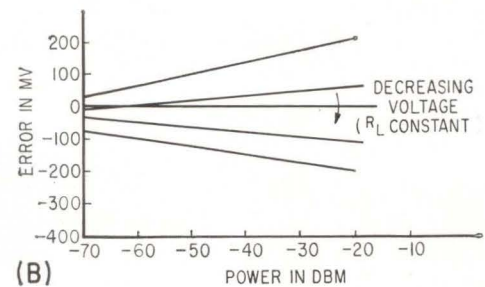

(B)

TEMPERATURE COMPENSATION of the load resistor decreases error at the high power levels (A); further improvement may be had by using a temperature compensated -6 volt supply (B)—Fig. 7

required for stability. By this means, the overall inaccuracy can be reduced to ± 50 mv with several points out only ± 100 mv (0.67 db).

TEMPERATURE EFFECT—Average error from the ideal curve as a function of input power with temperature as a variable, Fig. 7A, demonstrates the effect of optimum temperature compensation of R_L . The result is to decrease the error at high power levels at the sacrifice of increasing the error at low power levels, although the overall maximum is decreased.

Although compensating R_L proved sufficient for the particular application, further improvement is possible by introducing a temperature-variable -6 volt power supply. The required variation is only of the order of tenths of a volt, but has the effect of changing the slope of the error-vs-power curve as a function of temperature, Fig. 7B, thereby providing complete compensation along with a variable R_L .

Acknowledgment is given for the assistance of William McCarthy and Joel Byer in developing the complete amplifier. The basic logarithmic stage is the work of Allan Brown. Layout and fabrication of the thin film modules was performed by Varo, Inc., Garland, Texas, under subcontract to AIL.



AUTHORS Herzig (left) and Colbert check out the voltage monitoring system that they have developed

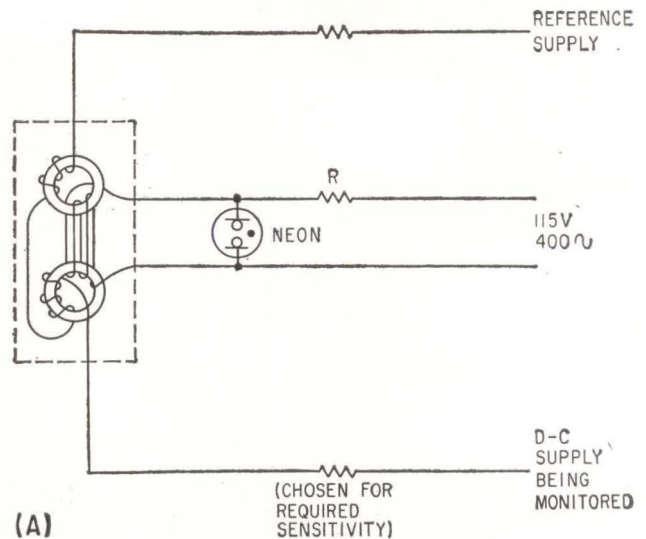

REDUCED inductance of saturated core (A) permits of different polarity (B), two control windings are

Voltage Monitor Needs Only Two

Supply being monitored is compared with reference. Difference voltage feeds saturable cores. Core saturation operates indicator lamp or closes relay

By MARIN C. HERZIG and DONALD C. COLBERT
Electronic Communications Inc., St. Petersburg, Florida

THE VOLTAGE MONITORING device described here is essentially a saturable reactor controlling a $\frac{1}{4}$ watt neon lamp as shown in A. The monitor-unit consists of two control windings and a signal winding wound on a pair of high-permeability cores. The control windings are connected between a reference supply and the voltage-divided output of the d-c supply being monitored. When the power supply output is at its proper potential, the voltages are identical and d-c current flows through the control windings, producing no d-c flux in the core. Consequently, the reactance of the 400-cps signal winding is high, the volt drop across resistor R is low and the neon indicator glows. If the d-c supply output increases or decreases from any cause, the difference in potential across the control windings causes a current-flow which will saturate the cores. The reactance of the 400 cps signal winding is then reduced, the drop across R is increased, and the neon indicator is extinguished.

Using a common commercial core material, a control winding current of about 0.2 ma will control full operation of the indicator. With more sensitive cores and more control-winding turns, a lower current of 0.05 ma will control the indicator. In a typical power supply, a voltage variation sufficient to cause 0.05 ma current differential is very small,

giving a high sensitivity figure to the indicator. Typical design data for a 400 cps indicator are given in the table. These values can be varied over wide ranges to provide an optimum design.

The minimum core size is limited chiefly by the physical size necessary for the windings since the power requirements are very low. The number of turns on the signal winding is a function of the core material since the inductance must be sufficient to develop the neon firing potential without self saturation when no d-c flux is present. Typical formulas are

$$E = 4.44 f N A_c B_m 10^{-8} \quad (1)$$

where E = impressed voltage (about 50 volts for a small neon), f = supply frequency in cps, N = number of turns, A_c = effective core area in square centimeters, and B_m = maximum flux density.

$$\text{Alternatively } L \approx \frac{1.25 N^2 A_c M_o 10^{-8}}{I_o} \quad (2)$$

REACTOR DETAILS

Core	Orthonic, 1.000 OD, 0.625 ID, 0.188 thick
Control Winding....	750 turns of No. 36 gage wire each winding
Signal Winding.....	500 turns of No. 36 gage wire
Lamp	NE51 or NE2
Limiting Resistor R..	56,000 ohms, $\frac{1}{2}$ W

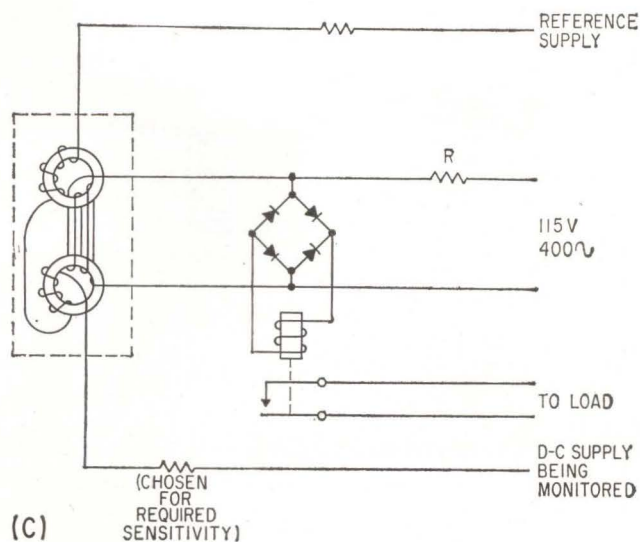
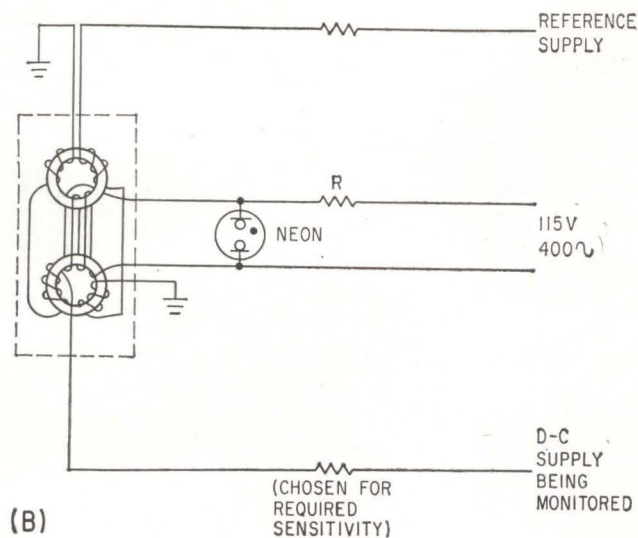

high value of 400-cycle current, turns off indicator through large drop in R . With reference and monitored supplies used. Sensitive relay can be used instead of indicator lamp (C) if remote indication is needed

Saturable Cores

current through control windings of contacts

where L = approximate inductance in henries, N = number of turns, A_c = effective core area in square centimeters, M_0 = initial permeability, and l_c = effective core length in centimeters.

The two cores used in the monitor balance out any a-c from the signal winding, which would otherwise be induced in the control winding by transformer action. Balancing-out the a-c is necessary, since it would appear in the power supply as increased ripple and could also saturate the cores, preventing proper indication.

The indicator can be used with any frequency in the audio range. Since the control power requirements are modest, the indicator would monitor audio and r-f potentials with the addition of a detector between these sources and the control windings.

An additional control winding identical to the first could be added to operate the indicator where the reference voltage and the power supply voltage to be monitored are of opposite polarity. B. This would have application in a multivoltage power supply using both positive and negative outputs and where a single indicator is desired. One control winding would connect between the reference and ground. The other control winding would connect in phase opposition between power supply voltage and ground.

By adding a relay and rectifier configuration as shown in C, an audible alarm or other high-power

REPLACING THE INDEX FINGER

Some electrical pioneers used to check working voltages by moistening a finger and placing it firmly on the live terminal. Their reactions were calibrated in the distance they jumped. Later came the conventional voltmeter, doubtless devised for the less hardy experimenters. And now, with a whole slew of stringent requirements placed on electronic equipment, even voltmeters are barely adequate. If the system vibrates, the voltmeter becomes unreliable; if lots of voltage sources are to be monitored simultaneously, a string of voltmeters takes too much panel space; and if a readout is required for under-voltage conditions, the meter gets prohibitively expensive.

Obviously, something simple and cheap is required to replace the meter—and saturable core units are just the animals. The only panel space needed is that required for a neon bulb. The bulb itself is also fairly rugged and the same pair of cores can operate a relay with few extra components

readout may be controlled by the saturable reactor. The unit will still sense over and under voltage conditions with only one relay.

The indicator can also be used as an accurate means of presetting a power supply voltage by adjusting the voltage until the light comes on. Since the indicator is a proportional control device rather than an on-off device, the output voltage may be adjusted for maximum lamp brightness, where low voltage sensitivity is involved.

REFERENCE

(1) "Reference Data for Radio Engineers," International Telephone and Telegraph Corporation, New York, N. Y.

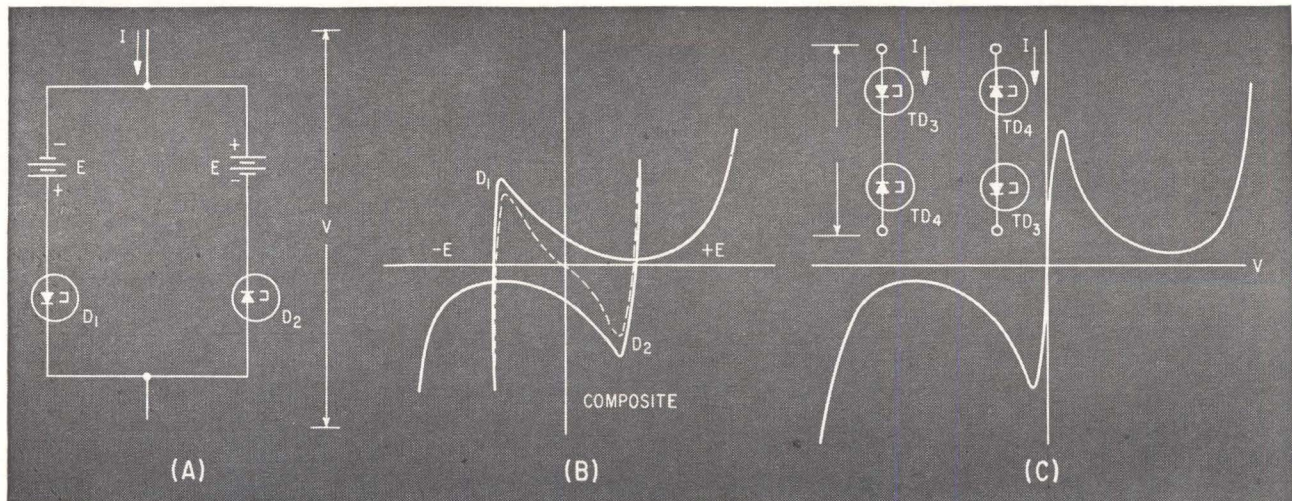

TUNNEL DIODE pair (A) produces the composite volt-ampere curve of (B). A series diode combination produces the curve of (C)—Fig. 1

How to Make Tunnel Diodes

Four tunnel diodes can be combined to produce a curve exhibiting three positive-resistance regions separated by negative-resistance regions.

This can be used to make a tristable circuit or a bipolar pulse generator

A NUMBER of solid-state devices have been developed that exhibit a negative-resistance characteristic. Notable examples are the tunnel diode, the avalanche transistor, the *pnpn* transistor and the unijunction transistor. A considerable body of information is available in the literature regarding the use of these devices as bistable elements, pulse generators, logic elements and amplifiers. However, little has been reported regarding the combination of negative-resistance devices to produce unusual terminal behavior.

Perhaps the best-known circuit that combines negative-resistance devices is the tunnel diode Goto pair. The composite volt-ampere characteristic of the Goto pair provides a convenient means of understanding the terminal behavior of the circuit, and an investigation of this characteristic reveals that the pair possesses many outstanding features not shared by the single tunnel diode.

This article shows that four tunnel diodes may be combined to produce a composite volt-ampere characteristic that exhibits three positive-resistance regions separated by negative-resistance regions. The salient features of the composite characteristic are shown and a tristable circuit and bipolar pulse generator described. These techniques also apply to the combination of other negative resistance devices.

TUNNEL DIODES—A tunnel diode is a two-terminal nonlinear device that exhibits a static volt-

ampere characteristic characterized by peak current, peak voltage, valley current, valley voltage and forward voltage. For an applied voltage less than valley voltage, the nonlinear characteristic is due to quantum-mechanical tunneling. For applied voltages larger than the valley voltage, the nonlinear characteristic is due to the usual forward conduction of a semiconductor junction. Because of this, the valley region is relatively broad and temperature dependent in contrast to the peak region which is sharp and well defined.

TUNNEL DIODE PAIR—One extension of the nonlinear characteristics of the tunnel-diode is the tunnel diode pair shown in Fig. 1A. This circuit combines the volt-ampere characteristics of two tunnel-diodes in such a way to form still another nonlinear characteristic. The composite volt-ampere characteristic is as shown in Fig. 1B. The volt-ampere characteristics of the individual tunnel-

THREE-LEVEL TUNNEL

Tunnel diodes have become type-cast as high-speed or high-frequency devices. Often overlooked is the fact that several tunnel diodes can be combined to produce unusual terminal behavior. As shown in this article, you can now build a simple circuit having three stable states

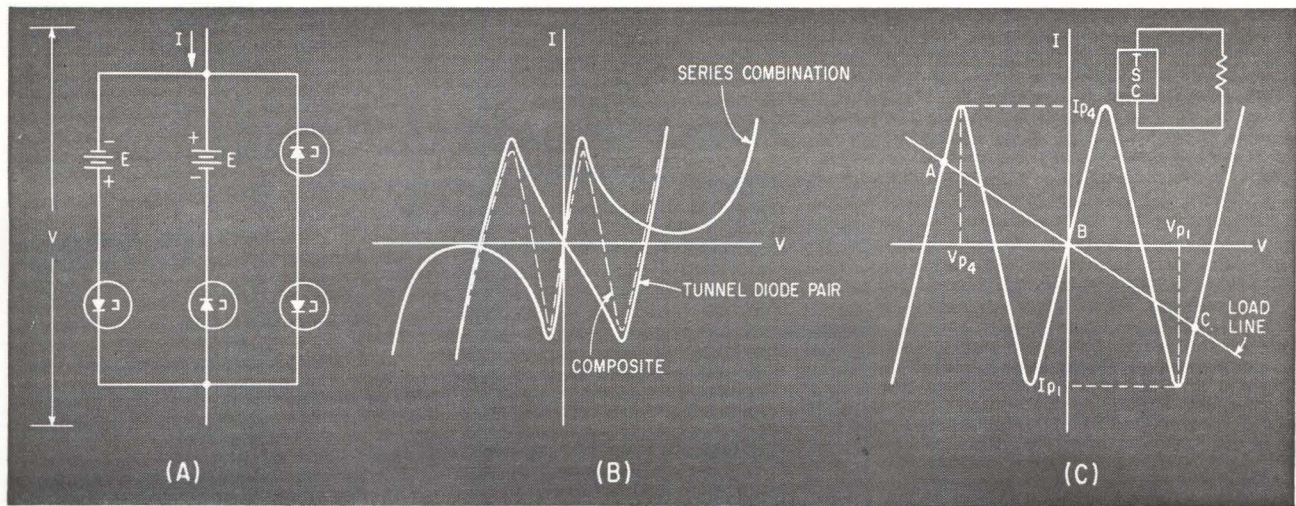

TRISTABLE circuit (A) produces the composite curve (B) with operation explained by (C)—Fig. 2

Even More Useful

By L. L. WILLIAMS and D. J. HAMILTON
 Department of Electrical Engineering
 University of Arizona, Tucson, Arizona

diodes used in the circuit are displaced along the voltage axis an amount equal to supply voltage E and then the values of current at any given value of voltage are added. The peaks of the pair characteristic are determined primarily by peak current of the individual diodes, thus both current peaks will be more stable with respect to temperature than the valley region of either tunnel diode used.

Two tunnel diodes may also be connected in series to form the volt-ampere characteristic shown in Fig. 1C. When one of the tunnel diodes is in the forward conduction region, the other is in the reverse tunneling region. Note that both connections have the same resulting volt-ampere characteristic.

A TRISTABLE CIRCUIT—A circuit having three positive-resistance regions separated by negative resistance regions, and which can be used as a tristable element is shown in Fig. 2A and 2B. This circuit combines both the tunnel diode pair and the series connection. For the peaks of the resulting volt-ampere characteristic to be maximum, it is necessary that the peaks of the pair characteristic occur at the valley voltages of the series connection. This requires that the supply voltages each be equal to $E = V_v + V_p$.

To maximize current peaks of the tunnel diode pair alone, each supply voltage should be set to $E = (V_v + V_p/2)$. Thus, a problem in selecting the optimum supply voltage arises and it is necessary to use diodes having different valley voltages for the pair and series connections. In the circuit to be discussed, gallium arsenide tunnel diodes were used in the pair circuit and germanium tunnel diodes were used in the series connection. For this configuration, each supply voltage should be set between $E = V_{v(Ge)} + V_{p(GeAs)}$ and $E = (V_{v(GeAs)} + V_{p(GeAs)})/2$.

Since valley voltage V_v of the gallium arsenide

tunnel diodes is considerably larger than the valley voltage of the germanium diodes, reasonable limits for the supply voltage can be set.

All four current peaks are primarily dependent upon the tunneling region of a particular tunnel diode in the circuit, therefore temperature problems attendant with the valley regions are minimized.

Tristable operation can be achieved by using a static load line which intersects all three positive-resistance regions. A simple implementation of this would be to connect a resistor in parallel with the circuit as shown in Fig. 2C. Since the load line must intersect all three positive resistance regions, the minimum resistance is either $(V_{p1}/-I_{p1})$ or $(-V_{p4}/I_{p4})$, whichever is larger.

APPLICATION—One application of the four-diode circuit is the generation of a bi-polar voltage pulse for the read-rewrite sequence of a tunnel diode memory and such a pulse is shown in Fig. 3A. The positive pulse reads the information out of the memory and the negative pulse rewrites the information destroyed in the read operation.

The volt-ampere characteristic of the tristable circuit is first altered by inserting tunnel diodes with different peak current ratings such that the current peaks of the composite characteristic will appear as shown in the lower curve of Fig. 3A. An inductor is then connected in parallel with the tristable circuit. Since the static load line coincides with the current axis, the circuit will have only one stable operating point located at the origin. This is under the assumption that the internal resistance of the inductor is negligible. The dynamic load line is horizontal, however, and intersects the composite volt-ampere characteristic at three points.

If a positive current pulse of sufficient amplitude is applied to the circuit, the operating point rises

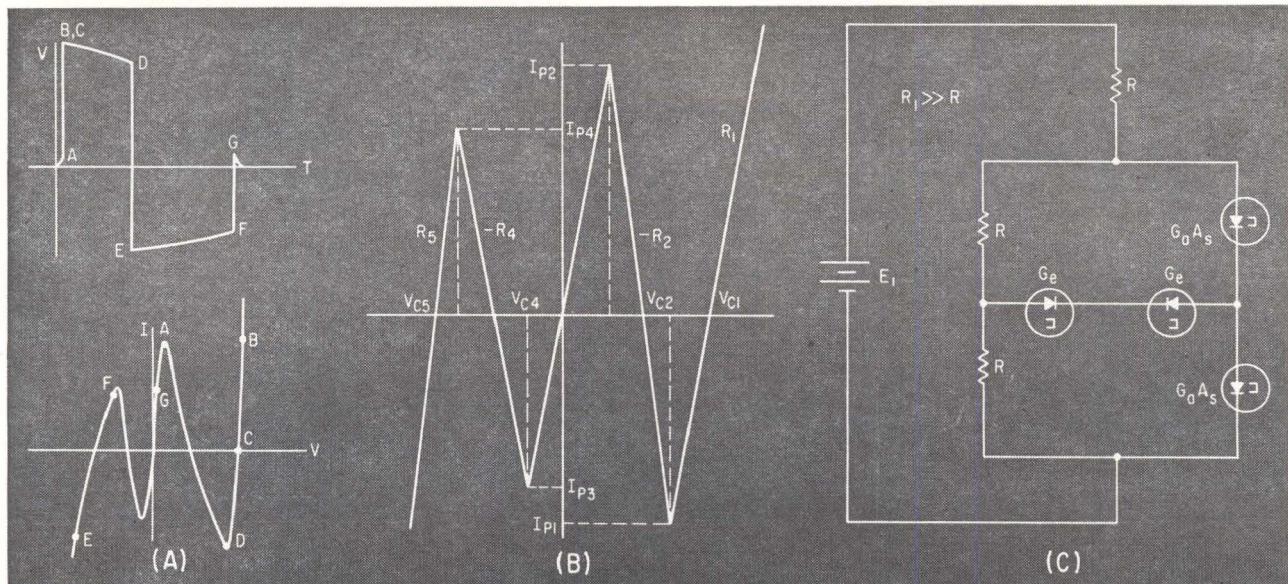

BIPOLAR voltage pulse with tristable composite curve (A). Linear equivalent model is shown at (B) and a practical circuit at (C)—Fig. 3

above the first current peak at A, and switches to B. When the trigger pulse is removed, the operating point moves to point C. This is under the assumption that the inductor is sufficiently large that the current in the inductor remains essentially zero during the application of the current pulse. The current in the inductor now increases until the operating point reaches point D; a further increase of inductor current causes switching to point E. A reverse voltage is now applied to the inductor and the current in the inductor builds up in the opposite direction. When the current reaches the value designated by point F, switching occurs to the center positive resistance region to point G. The current in the inductor then decreases and the operating point moves back to the origin.

The output voltage across the circuit during the time it is in the transient condition will be a bi-

polar voltage pulse similar to the one shown in Fig. 3A. By a similar reasoning it can be seen that if a negative current pulse is applied to the circuit, a single negative voltage pulse will be generated.

The length of either the negative or positive voltage pulse can be found by considering a linear equivalent model (Fig. 3B) of the circuit while it is in either of the positive-resistance regions. The value of the voltage source is the zero current crossing point of the composite volt-ampere characteristic in the particular region of interest. One of the series resistors is equal to the effective resistance of the composite volt-ampere characteristic and the other is equal to the internal resistance of the inductor. The pulse length is given by $T_L = (L/R) \log_e [(I_i - I_f) / (I_e - I_f)]$.

Here, I_i is the initial current in the inductor and I_e is the value of current at which the circuit will switch to another stable state. The final value I_f is found by dividing the equivalent source voltage by the sum of the inductor internal resistance and the approximate circuit resistance obtained from the composite characteristic.

PRACTICAL CIRCUIT—A practical circuit for the generation of bipolar voltage pulses is shown in Fig. 3C. When constructing the composite volt-ampere characteristic, include each internal resistance R by considering it a resistance in series with each of the tunnel-diodes used in the tunnel-diode pair.

The positive-resistance regions of an experimental device are shown in Fig. 4A. Since the sweep mechanism was essentially a current source, negative resistance regions are not evident. The gallium arsenide tunnel diodes that were used in the tunnel-diode pair configuration were rated at 10 ma peak current. The germanium tunnel-diodes used in the series combination had peak currents of 20 ma and 4.7 ma. A bipolar voltage pulse from this particular circuit with an inductor of 0.9 mh is shown in Fig. 4B. A much higher speed voltage pulse is shown in Fig. 4C. For this circuit an inductor of 3.8 μ h was used.

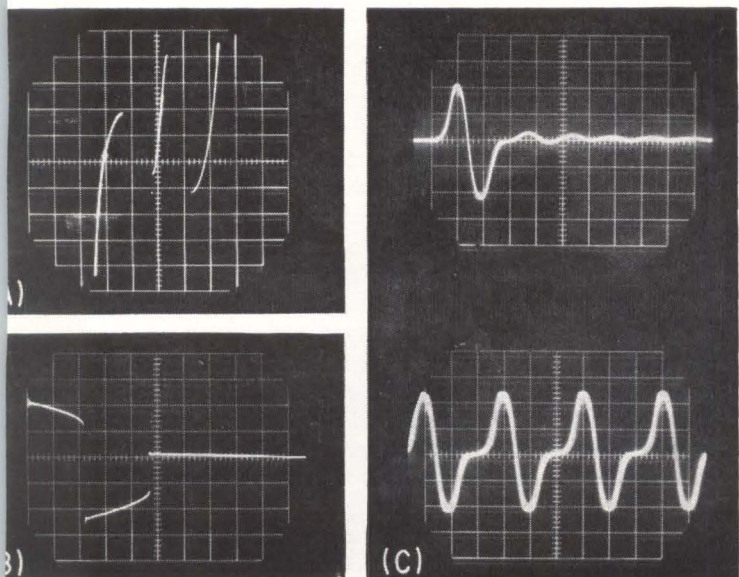

TRISTABLE volt-ampere characteristics (A), bipolar voltage pulse (B) and bipolar voltages with high-speed pulses shown at (C) Fig. 4

THIS RECORDER WEARS TWO HATS

Practically every instrumentation tape recorder has two heads, but this is the only one that wears two hats. Wearing the first, it records and plays back in the conventional reel-to-reel manner. (Not **entirely** conventional, at that — the reels are uniquely stacked to provide at least a 2:1 saving in space over ordinary recorders).

Wearing its other hat, the instrument becomes a continuous loop recorder (either fixed or variable) that will run circles around anything else you've ever seen . . . in such jobs as monitoring recording, repetitive analysis, and continuous recording and playback.

Changing hats is as simple as, well, changing hats.

Because the tape is housed in compact, interchangeable magazines, you need merely detach the first and snap the other into place, in seconds. No need to rewind or wait until the end of the reel; the interchange can take place at any time, any place on the tape.

We'd like to show you some of the many other useful features of the highly versatile PI-200 recorder. One of these features — its great economy of space and weight — will enable us to carry a 14-channel demonstrator into your laboratory in one hand. May we? For a copy of our PI-200 brochure, address us at **Stanford Industrial Park, Palo Alto 20, California.**

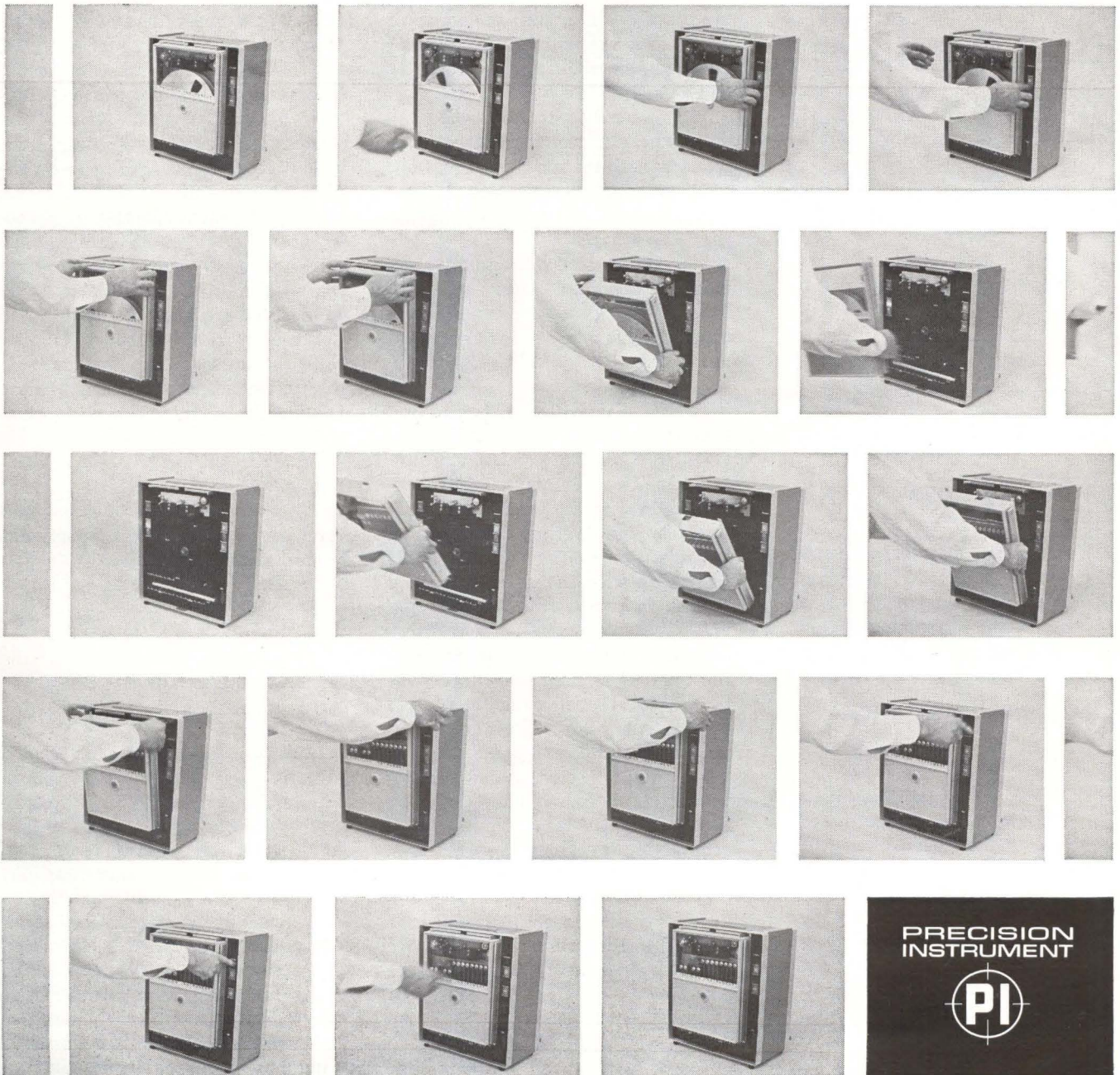

Computer Translates Chinese into English

*New IBM device
may speed processing
of technical texts*

YORKTOWN HEIGHTS, N. Y.—Machine translation from Chinese into English has been achieved on a limited scale by IBM Research Laboratories here, working under sponsorship of the U. S. Air Force.

Heart of the system is an ingenious method of encoding the thousands of Chinese ideographs into digital language, in the form of punched tape (18 bits per character), a process which can be done by an operator without any knowledge of Chinese, simply on the basis of geometrical comparison. The present input unit uses a modified typewriter.

Once the ideographs are entered on tape, they are then subjected

to the basic steps of machine translation:

(1) Automatic dictionary lookup, which divides up the input stream into meaningful words and phrases,

(2) Addressing system, which compares the resulting "record lengths" of symbols against a store of words (2,000 at present) on a photographic disk film memory, and finds the longest possible match for each sequence. This match may be a phrase, word or subclause, and provides grammatical and semantic tags to identify each part of the sentence.

(3) Automatic grammatical analysis, which scans each Chinese sentence five times to check for word sequences and special words that may have an effect on the meaning, and finally

(4) Automatic contextual analysis, a process that tries to identify words which remain ambiguous even after grammatical analysis.

CODING CHINESE—The coding system is based on a system devised by Chinese novelist Lin Yutang. It classifies about 6,500 ideographs into groups which have the same or similar top and bottom features. When the operator finds the group with the correct top and bottom features, an automatic display presents a table containing all the words with these two features. It is then only necessary to match the desired character with one on the table and punch out the appropriate number.

The input device, called a Sino-writer, is being built jointly by IBM and the Mergenthaler Linotype Company for the Air Force Information Processing Laboratory. It is expected that non-Chinese-speaking operators can be trained to type Chinese characters into the translator at rates comparable to ordinary typing of English. It is expected that the vocabulary can be increased to about 16,500 characters, necessary

for general translating.

Present translating speed of machine is limited only by input and output operations. IBM spokesmen told **ELECTRONICS** that there are no plans as yet for using automatic pattern recognition for encoding ideographs, on account of their extreme complexity.

WORD MEMORY—The processing unit that actually does the translating makes use of the same type of large-capacity memory used by IBM for Russian translation. The memory can store some 500,000 Russian words, along with grammatical rules and other translation information. Storage is on 11-inch photographic film discs, with tracks of black rectangles photographed on it on a $\frac{3}{8}$ -inch path near the outer edge. The $\frac{1}{2}$ -million instructions are represented by 60 million binary bits.

Readout is by narrowly focused light beam scanning the rotating disc using a photocell. This process is used for matching words; when a match is found the code for it is transferred into a storage register. Average time to find a word on the disc is 1/30 of a second. Each word is followed by pertinent grammatical information.

Direct MHD Conversion Seen By Air Force Report

ELECTRICAL ENERGY can be extracted directly from hot ionized gas, in the opinion of Air Force researchers, according to a newly released joint RCA-Air Force report on electrodeless MHD generator research.

In seeking a simplified MHD (magnetohydrodynamic) induction generator, analysis was made of the electrical and gas characteristics of a travelling-wave type generator. In such a unit, a-c power would be taken out by electromagnetic induc-

近來發現磁心的開關時間
可以縮短,故能用它來做
更高速的存儲器了。

WORD-FOR-WORD TRANSLATION:

Recently discover/discovery magnetic core (de) switching time possible shorten, therefore use/consume it come make even high speed (de) storage device (le).

MACHINE TRANSLATION:

Recently discover switching time of magnetic core possible shorten, therefore possible use it in order to make storage device of even higher speed.

HUMAN TRANSLATION:

It has been discovered recently that the switching time of magnetic cores can be shortened. They, therefore, can be used to make storage devices of even higher speed.

ITT TUBES FOR RADAR SYSTEMS

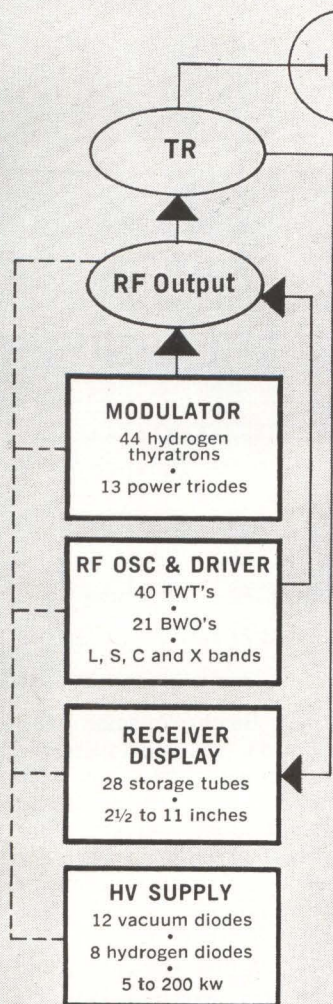

For today's radar and ECM systems...166 tube types by ITT

HYDROGEN THYRATRONS—ITT Kuthe makes the most complete line on the market today . . . 52 basic types including the industry's broadest line of metal-ceramic types designed to operate at high repetition rates and high temperatures in radar pulse circuits.

HV POWER TUBES—ITT offers a full line of basic types from 5 to 200 kw, including the most complete line of coaxial, ceramic, and evaporative cooled tubes

available. 25 types are specially designed for radar switching, rectifier, clipper and charging applications.

STORAGE TUBES—ITT offers the industry's most complete line with 28 types from 2½ to 11 inches. Features include ITT's exclusive ring flood gun which eliminates trapezoidal distortion. Writing speeds up to 500,000 ips and erase times as fast as 1 millisecond with high brightness for radar display.

TWT's—ITT has recently added a complete line of PM BWO's to its existing lines of 40 TWT's and 21 BWO's. Latest TWT introduction is series of light, rugged 1 kw metal-ceramic tubes ideal for ECM and radar driver applications in L, S, C and X bands.

These types are available today. Write for complete specs. If you have a unique problem which one of these 166 types won't solve, please tell us about it. We'll be happy to come up with number 167.

ITT ELECTRON TUBE DIVISION

CLIFTON, NEW JERSEY

INTERNATIONAL TELEPHONE AND TELEGRAPH CORPORATION

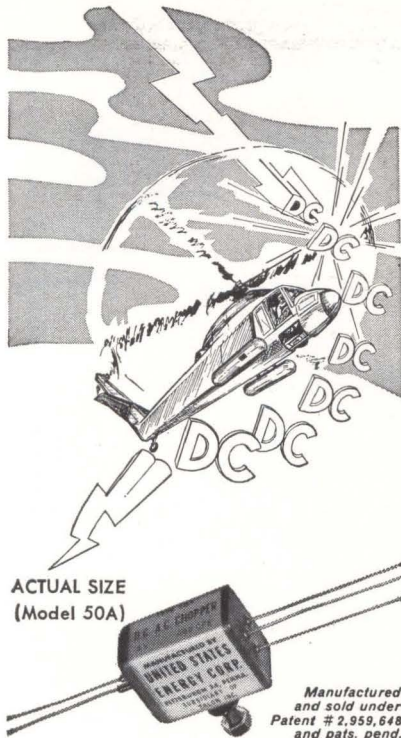

WHICH CHOPPER WOULD YOU DESIGN INTO YOUR SYSTEM?

Experienced pilots recognize the versatility of the big chopper pictured above. Upon inspection, seasoned electronic engineers will be quick to recognize the versatility of USEC's new line of Talon DC-AC choppers. They offer extremely low noise level, low driving power and are inherently reliable. Offered in many different packaging configurations, both plug-in and wire-in, the new line of Talon DC-AC choppers are hermetically sealed and provide unequalled flexibility of application. The new line of Talon DC-AC choppers are normally supplied for operation from a DC-450 CPS 6V source. Inquiries for special requirements are welcomed.

Write today for complete operating specifications.

usec / UNITED STATES ENERGY CORP.
 (A Subsidiary of Talon Inc.)
 300 MT. LEBANON BLVD., PITTSBURGH 34, PA.
 Telephone (412) 561-3440

Ad #634

tion, thus eliminating electrodes.

A possible design of such a generator uses a large tube open at one end and having a hollow sphere at the other end. Heated air passes over coal in the hollow sphere and into the duct. Electrical coils placed along the duct create a magnetic field.

The report concludes that supersonic operation of the generator would yield higher power densities than subsonic operation. Power factor characteristics would be improved by adding a ferromagnetic material outside the generator. Predicted power factors are 0.2 to 0.4, with a 60-cps frequency and the conductivity of the working fluid of 100 to 200 mhos per meter.

Xeledop Trolls for H-F Antenna Patterns



BOMB-SHAPED transmitter is fitted in flight with vertical 10-ft dipoles above and below, and a 16-foot trailing dipole

FIRST AIRBORNE tests of Stanford Research Institute's Xeledop (Transmitting Elementary Dipole with Optional Polarity) prove out the feasibility of towing by airplane a multichannel, battery-powered transmitter through the electromagnetic fields of large h-f antennas to measure their patterns.

Trailing 200 feet behind the airplane at the end of a nonconducting plastic line, the device pulses four times per second on four different crystal-controlled frequencies in sequence, and simultaneously provides data for establishing four different antenna patterns.

Dipole for picking up vertical polarization consists of two 10-foot

HOW do you want to record your TRACES?



Continuous Flow?



Single Frame?

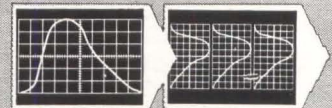

Polaroid® Prints?

The new Beattie-Coleman KD-5 Oscilloscope camera is a most versatile 'scope camera. Available with continuous-flow 35mm electric magazine, 35mm electric pulse magazine or Polaroid back for 10 sec. prints. Dichroic mirror for simultaneous, parallax-free viewing. Rotates 90° for vert. or horiz. format. Hinged mounting for easy focusing.

RECORD DATA, TOO

Written data, counter and 24 hr. clock can all be recorded on same frame as trace. Write for information on the full Oscilloscope line.

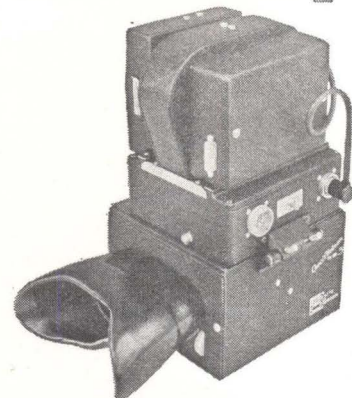

Beattie-Coleman INC.

1004 N. OLIVE ST., ANAHEIM, CALIFORNIA

CIRCLE 201 ON READER SERVICE CARD

June 7, 1963 • electronics

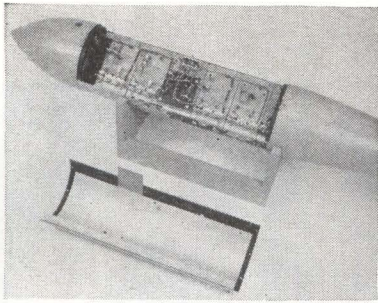

CASING is removed to show four transmitter sections. Each section transmits for 1/5 second each second on its own frequency

sections of wire, one weighted to hang vertically from the bottom of the device's fiberglass casing and the other suspended vertically from the tow line to the device. The horizontal dipole consists of a 16-ft end-fed wire trailing behind Xeledop, and horizontal members of its chassis.

In tests to date, the pilot of a Beech T-11 trainer has flown precise circles around the antenna at distances up to 10 miles and altitudes to 12,000 feet.

Four receivers on the ground, linked by a multicoupler to the test antenna, picked up a range of signal elevations. Outputs from the receivers, and from optical tracking equipment which established the plane's azimuth and elevation, were fed into a multichannel recorder. Strip-chart read-out correlated position of the transmitter with relative field strength measurements and the end result was the relative field-strength pattern of the test antenna at each frequency and polarity.

SRI reports that the device can satisfactorily establish patterns for any type of large h-f antenna, such as rhombic, log-periodic, open-V, and longwire structures.

In the past, single-channel transmitters have been towed by helicopter for pattern measurement (ELECTRONICS p 134, Nov. 1955). While that technique is slower and more expensive than the Xeledop method, it overcame the shortcomings of testing radiation patterns by scale models. Model testing is oblivious to variations stemming from the magnetic profile peculiar to the specific terrain, and to re-radiation from nearby antennas.

**Fred
Roberts***
can
show
you ...

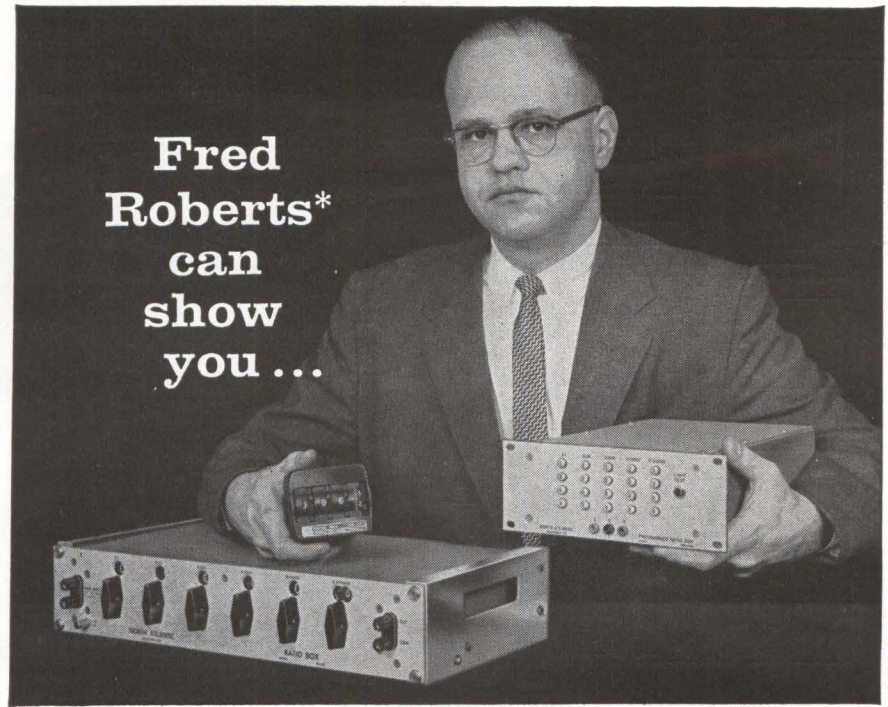

*Director of Marketing, North Atlantic Industries

how to measure ac ratios to 1.0 ppm ...at a sensible price

In fact, any of North Atlantic's field representatives can quickly demonstrate how NAI's Ratio Boxes will economically meet critical requirements for AC ratio measurements—in the laboratory, or in field and production testing.

These high-precision inductive voltage dividers are available in a complete range of models for particular applications. Standard types include Model RB-503 for bench or rack use, the miniaturized RB-521 for panel mounting in military specification equipment and PRB-506, a versatile system module programmable from punched cards or tape for automatic testing. Abridged specifications of these models are given below.

MODEL	RB-503	RB-504	RB-521	PRB-506
	RACK OR BENCH	RACK OR BENCH	MINIATURE PANEL MTD.	MINIATURE PROGRAMMED
Ratio Range	0.000000 to +1.111110	-0.111110 to +1.111110	0.0000 to +1.1110	0.0000 to +1.111110*
Nominal Accuracy (Term. Linearity)	10 ppm	1 ppm	10 ppm	10 ppm
Freq. Range (Useful)	50 cps-10 Kc	50 cps-3 Kc	50 cps-10 Kc	50 cps-3 Kc
Input Impedance at 400 cps	> 60K	> 200K	> 50K	> 50K
Nominal Input Voltage Ratings (f in cps)	0.5f volts 350v max.	1.0f volts 350v max.	.35f volts 300v max.	.35f volts 300v max.
Maximum Output Series Resistance	3.2Ω	8.0Ω	3.5Ω	3.4-3.9Ω*
Resolution	5 decades plus pot.	5 decades plus pot.	3 decades plus pot.	3, 4, 5 or 6 coded decades
Size	19" x 3 1/2" x 8" d	19" x 3 1/2" x 8" d	2 1/2" x 3 3/4" x 6 1/4" L.	9 1/2" x 3 1/2" x 13" d
Price	\$295.00	\$450.00	\$275.00	\$900 to \$1500*

Abridged specification—send for full details

*Depends on number of decades

Also from North Atlantic: Model RB-510 for 2.5ppm precision at 10kc, RB-503T and -504T with ratio ranges from -1.111110 to +1.111110, and PRS-531 Resolver Ratio Simulator.

For complete technical and application data, write for Data File RB, or contact the North Atlantic man in your area.



NORTH ATLANTIC industries, inc.
TERMINAL DRIVE, PLAINVIEW, L. I., NEW YORK • OVERbrook 1-8600

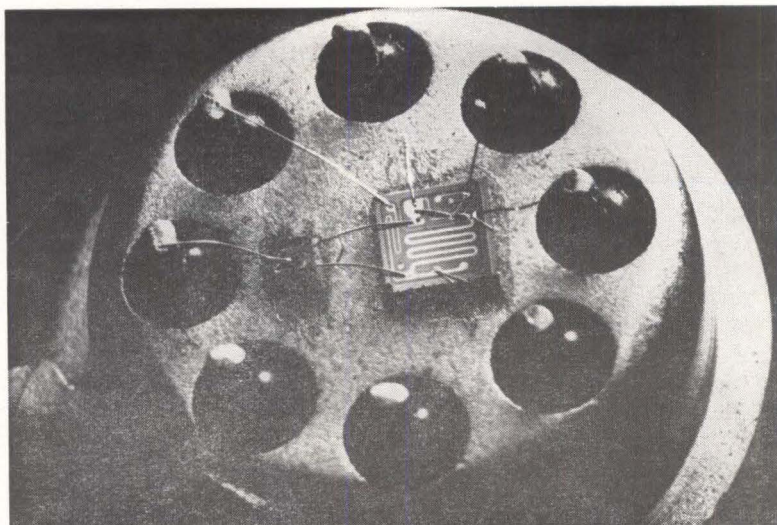
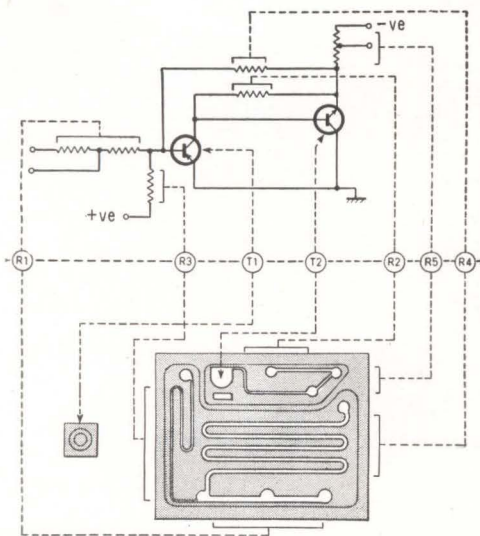

INTEGRATED silicon microcircuit by Ferranti Ltd. is constructed from two silicon chips and contains two transistors and six resistors. Photo of circuit at right shows mounting in a reduced height JEDEC TO-5 case

Microcircuits Are Busting Out in Britain

Production starts in thin film and integrated circuits

By DEREK BARLOW,
McGraw-Hill World News

LONDON—Microminiature units cheaper than conventional component assemblies, new modular construction methods, high power waveguide loads and calorimeters, a new piezoelectric ceramic material and microminiature 300 Mc planar transistors were the highlights of the recent British Radio and Electronic Component Exhibition held here. Attendance at the show was a record-breaking 49,000, while over 250 exhibitors represented Britain's burgeoning component industry.

Component output in Britain is now running at 3,000 million components a year, with a sales value of \$384 million for 1962/63—an increase of more than 6 percent over 1961.

THIN FILMS — Greatest talking points of the show was industry's

commercial adoption of microminiature elements and the number of companies offering either production thin film units, or fully integrated solid state circuits. Of the British companies now in full production on thin films, the Welwyn Electric Co. is producing 1,000 circuits a week and expect to produce 10,000 a week by the end of the year. Welwyn anticipate that in five years 50 percent of all their turn-over will be from thin film circuits, with main applications in logic elements.

Another manufacturer, Elliott Brothers Ltd., is switching over its Minilog logic system entirely to thin film circuits; this step alone will require ½ million thin film units next year.

The Welwyn system uses high alumina ceramic as the base of the film substrate. The advantages claimed over glass substrates include higher strength, production in any geometry, higher thermal conductivity giving uniform heat distribution without hot spots, and better control over surface smoothness allowing better film adhesion. Films of nickel alloy are deposited

with resistance from 10 ohms to 50 kilohms with 1.5 watt per sq. in. dissipation. At this power, resistance does not change after the first 1,000 hours more than 0.04 percent per thousand hours. Capacitors are formed from aluminum plates and silicon dioxide dielectric. While costs of the substrate are 25 to 50 percent higher than for the individual unwired conventional components, thin films are cheaper when compared with final wired assemblies of conventional components.

Also in production with thin film circuits for industrial applications is Mullard Ltd. Using a glass substrate 30 × 20 mm, Mullard is currently achieving packing densities of 350,000 components per cubic foot. Circuits developed to date include 50 Mc oscillators and 65 Mc video amplifiers. In the oscillator a 0.7 microhenry inductor was vacuum deposited.

CIRCUIT PACKAGING — While not giving packing densities anything like thin films, a new component packing system, Ministac, developed by Standard Telephones and

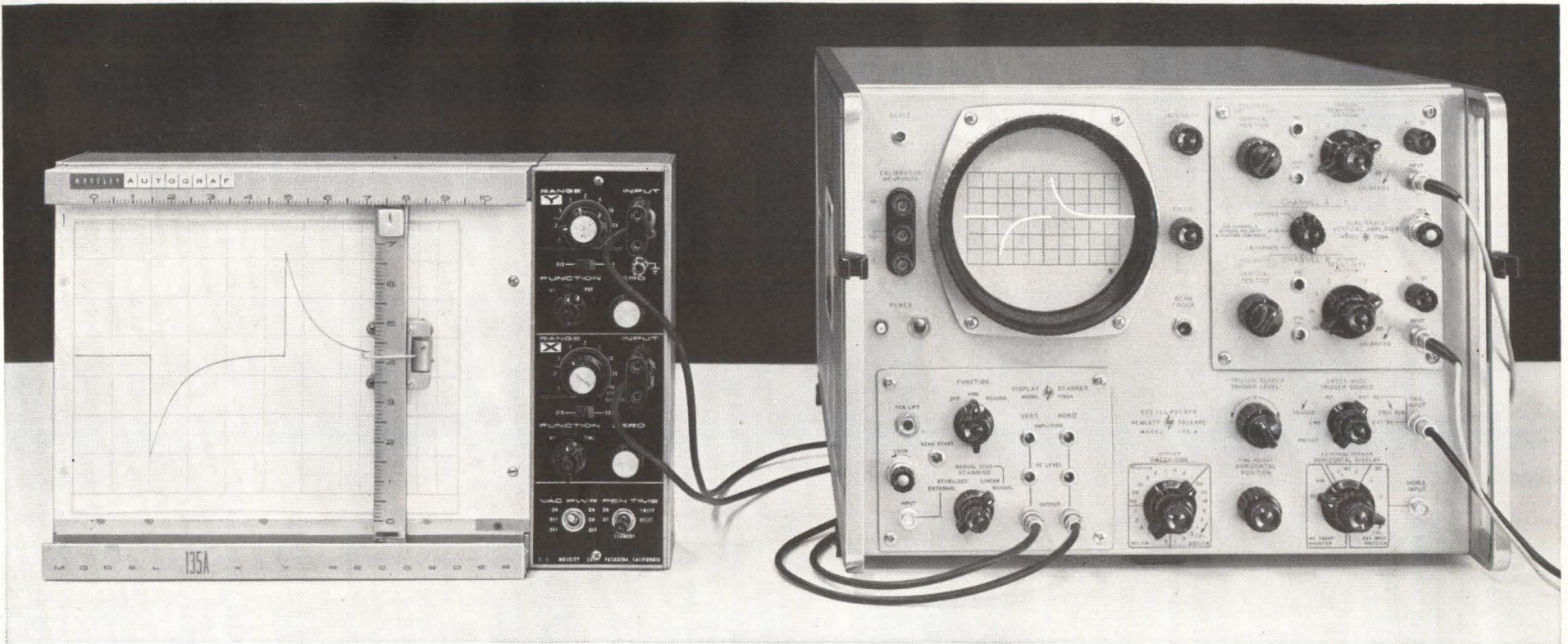

High resolution, permanent recordings of waveforms displayed on the hp 175A 50 MC Oscilloscope are now possible with the new hp 1782A Display Scanner Plug-in.

Used with an x-y recorder, such as the Moseley 135 or 2D, the plug-in transforms high speed phenomena to the bandwidth of the recorder and permits large, permanent recordings to be made. The x-y plots provide greater resolution than photographs, are easy to study and keep as permanent records.

This new plug-in offers new versatility for your hp 175A — a 50 mc universal oscilloscope which combines these

PLOT SCOPE TRACES

with your hp 175A 50 MC Oscilloscope

unparalleled advantages:

- Full 6 x 10 cm no-parallax display
- Rise times of less than 7 nsec at all sensitivities
- Sweep speeds to 10 nsec/cm
- Vertical and time axis plug-in versatility
- Easy to calibrate, easy to maintain

Get complete details on the 175A, its dual trace, fast rise and high gain plug-in amplifiers, and its horizontal

plug-ins for sweep delay and time marker. A call to your hp representative will bring a 175A to you for comparison against any high-frequency scope. hp 175A, \$1325 without plug-ins; hp 1782A Display Scanner, \$425.

Data subject to change without notice. Prices f.o.b. factory. 8433

**HEWLETT
PACKARD
COMPANY** 

1501 Page Mill Rd., Palo Alto, Calif., (415) 326-7000. Sales and service representatives in principal areas. Europe, Hewlett-Packard S.A., 54 Route des Acacias, Geneva, Switzerland; Canada, Hewlett-Packard (Canada) Ltd., 8270 Mayrand St., Montreal, Quebec.

RELIABLE
MODULES
ARE
POTTED
IN

TIMONIUM

timonium (ti-mō'nyum), n, Mod. L., an extremely rare and reliable element, found only in a certain political subdivision of Maryland, and having a consistent and very distinctive set of physical (both organic and inorganic) properties, e.g., facilities, people, experience, and a composition that can be expressed only by the formula EMC.

EMC

ELECTRONIC
MODULES
CORPORATION

1949 GREENSPRING DRIVE • TIMONIUM, MD.
CLEARBROOK 2-2900

DIGITAL LOGIC MODULES • DIGITAL
EQUIPMENT AND CUSTOM PACKAGING

Cables Ltd. (ITT subsidiary) consists of two side mouldings each carrying the required circuit configuration on a two layer grid system with slotted solder terminals on a 0.1 in. pitch for mounting components. The side mouldings are supported by a pair of end plates which carry the external module terminals. Internal connections to these terminals are made by the end tags on the side assembly, with a maximum of four connections per end. End plates can also be mounted within the module.

The wiring pattern is formed from a 0.01 in. thick nickel-silver sheet punched with a standard pattern. To form the wiring pattern, the unwanted portions are cut away and the remainder is mounted on the moulding to form an interconnecting side assembly.

MICROWARE — Integrated circuits too are moving from research and development into production. Already Hughes, Texas Instruments, and SGS-Fairchild are marketing units in Britain. But new to the integrated circuit field is the British firm, Ferranti Ltd. Developed with only minimal government backing, the Ferranti system does not rely on integrating all circuits in one silicon chip. Often multiple chips are used, interconnected by thermocompression bonded gold wires. Linear amplification units and high speed logic circuits are now available. The linear units include a servo amplifier, demodulator and a 100 Mc linear amplifier with a 7.5 current gain. In addition to conventional single and double entry NOR gates and emitter followers, a transient memory unit is under development to allow serial machines with clock rates up to 5 Mc. Typical delay times of the gate units are less than 12 nsec.

FASTER SEMICONS—One experimental microminiature 300 Mc silicon planar transistor developed by Mullard is only 0.05 inch in diameter. A three-lead *npn* device for direct soldering on microcircuit substrates, the transistor has an amplification factor of 40 to 120 with 10-ma collector current. An experimental planar diode, also from

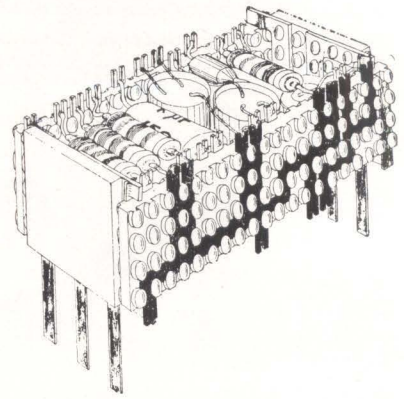

TYPICAL ministac circuit with wiring on side mountings; dark side-sections are wiring punched from standard material

Mullard, is claimed to have better piv rating, forward drop and shunt capacitance characteristics than present devices. Its recovered charge is less than 20 picocoulombs at 10 ma and it has a piv of 50.

Other new semiconductor devices on view include first U.K. production avalanche rectifiers. An STC 1.25-amp rectifier operates with a 1,000-v reverse working voltage and 4-kw energy dissipation; an Associated Electrical Industries 1,200-v all diffused rectifier handles 10 amps.

Application of Boff snap action diodes in pulse shaping networks sharpens up the leading edges of the pulse. A new diode developed by Ferranti obtains rise times of one nanosecond from 20-ns pulse generators. In the diode, the magnitude of the forward current control the delay time of the high reverse conduction period up to 100-ns. Transition from this state to reverse blocking takes 0.8-ns.

PIEZOELECTRIC IGNITION—In the other component areas the most significant innovation was a new high sensitivity ceramic piezoelectric material capable of generating automobile ignition sparks directly. Developed by Mullard, the substance, primarily a lead zirconate titanate, generates 400 v per millimeter of thickness when subjected to a 7,000 lb. psi pressure. Piezo sensitivity up to 100 v/mm per kg/mm² is controllable by the amount of polarization imparted to the material during manufacture.

Highlights from the remainder

of the show include:

• High power microwave loads and power meters developed by Marconi's Wireless Telegraph Company Ltd. now allow on-line measurements up to 3-kv. The new load, shown for the first time, consists of a ceramic compound moulded integrally into a normal length of waveguide to produce a taper from all four internal corners of the waveguide. This new ceramic absorbs power at a much higher rate than other types of load material, while the shape of the moulding produces an even absorption of power throughout the material. Maximum power dissipation is governed by surface temperature. Specially brazed and reinforced ends allow waveguide pressures up to 60 lb./in² while surface temperature maximum is now 300C, although up to 450C can be tolerated under certain conditions.

The power meter operates up to the same power level and comprises a high power waveguide load surrounded by an oval-shaped water jacket maintaining good thermal contact between the waveguide wall and the cooling water. Thermocouples mounted at the inlet and outlet water connections measure the water temperature rise.

• Vacuum capacitors now being manufactured by the English Electric Valve Company will handle up to 40 amps and provide tunable capacitance ranges of 5 to 750 pf. Other types extend the range to 2,000 pf.

Development is under way to raise current capacity to 75 amps.

• A new component fixing technique that eliminates all circuit board punching or drilling has been successfully developed by J & S Engineers Ltd. The hydrostatic method employed enables relatively soft objects to be punched through harder materials. The component being inserted acts as its own punch and locks itself securely within the circuit board. Special brass terminations are swaged onto the component lead wires, which are then cropped and formed to shape before punching.

On punching, the termination secures itself mechanically and connects electrically with the printed circuit wiring.

Dunco reed relays

15 VA Contacts

...But Don't Overlook Low Level Circuits!

Typical Struthers-Dunn reed relays give millions of reliable operations at rated loads . . . many more million operations at low levels. Tiny, inexpensive, extremely fast, and with, oh, so many contact possibilities, they're doing jobs that could never be done before by conventional relays.

And, That's Not All—they offer . . .

- Complete Mechanical Protection
- Contaminate-Proof Contacts
- Only 1 Moving Part Per Pole
- 1 to 2 Millisecond Operation
- Form "A," Form "B," Form "C" Contacts
- 4 or 15 VA Contacts
- Magnetic Latching Contacts
- Magnetic Shielding
- Mount in Any Position
- Low-Cost Logic

But, for the complete story on the industry's most complete reed relay line, write for Catalog B. Address: Struthers-Dunn, Inc., Pitman, N. J.

STRUTHERS-DUNN

5,348 Relay Types



Member, National Association of Relay Manufacturers



Sales Engineering Offices in: Atlanta • Boston • Buffalo • Charlotte • Chicago • Cincinnati
Cleveland • Dallas • Dayton • Denver • Detroit • Houston • Kansas City • Las Vegas
Los Angeles • Memphis • New York • Orlando • Pittsburgh • St. Louis • Salt Lake City
San Antonio • San Diego • San Francisco • Scottsdale • Seattle • Wichita. Canadian Licensee:
Renfrew Electric Co., Toronto, Ontario, Canada. Export Department: 1505 Race St., Philadelphia 2, Pa., U.S.A.

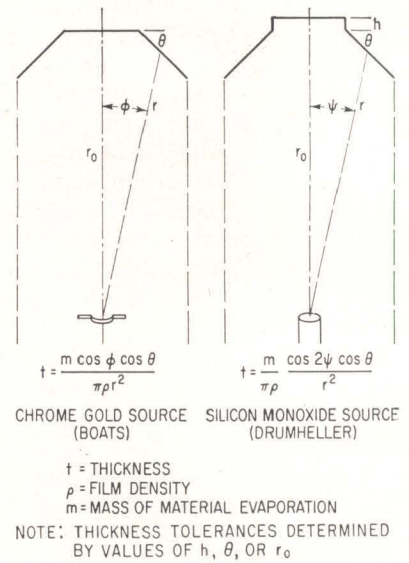
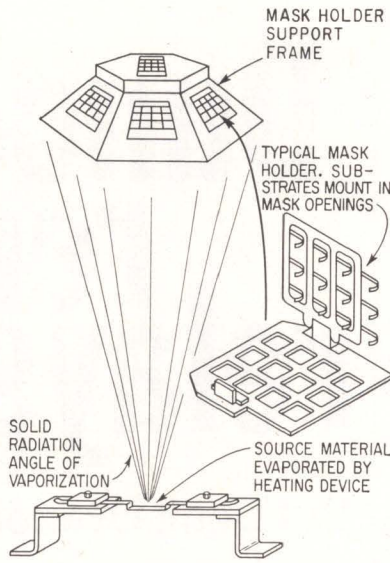

ONE-SHOT process equipment (left), shown with vacuum chamber removed, deposits films on several substrates with one firing of source material. Diagram (center) shows details of substrate holder and general location with respect to source material. Geometric diagrams (right) are used to accurately position holder with respect to source material in accordance to material used; note also modifications in shape of holder's support frame to accommodate silicon monoxide deposition—Fig. 1

Pilot Plant Mass Produces Thin Films

By R. D. KRAUS, Solid State Systems Division, Motorola Inc., Phoenix, Arizona

Processes turn out several thousand units daily

VACUUM DEPOSITION of thin-film circuits, which in the recent past has been subject to the vagaries of uncertain personal control, now appears to be achieving basis for practical mass production. Demand for thin-film circuits over the past few years has increased efforts in this direction. Motorola has set up an engineering pilot-production facility to meet this demand and also to preview and evaluate mass-production feasibility. This is a moderate cost facility. Using multiple shifts, it has a production capability of several thousand units per day. While not using full automation (not now economically justified), those steps requiring very precise control are automated. Thin-film elements in production are: chrome gold conductors and

RECIPES AND MASS PRODUCTION

Not long ago, the successful thin-film vacuum worker was described as being almost as much an alchemist as a physicist. He followed "recipes" telling how to: clean surfaces, set deposition, rate, time process, select evaporant metal, preserve metal film once formed, etc. Such personalized approaches cannot be followed in mass thin-film production now attaining practicality

soldering pads; silicon monoxide capacitors; tantalum oxide electrolytic capacitors; nichrome resistors.

BASIC PROBLEMS—Production setup at the pilot plant had to overcome basic problems common to all thin-film vacuum deposition outside as well as inside the electronics industry. These problems hinge around the basic process mechanism of heating a source material in a vacuum atmosphere and collecting resultant vapor on a smooth surface. Critical in this operation are: source material form (slug,

wire, granule, powder, ribbon) and amount, both effecting ease of evaporation (amount of exposed surface); makeup of device for heating source material as effecting device life and contamination of source material and film; substrate temperature; oxide coating formation during deposition; proper positioning of substrate with respect to source to obtain uniform deposition. In solving such problems, and others peculiar to processes, standard vacuum evaporators were modified.

Probably the most difficult prob-

In FIXED COMPOSITION RESISTORS

if it's news, expect it first from IRC

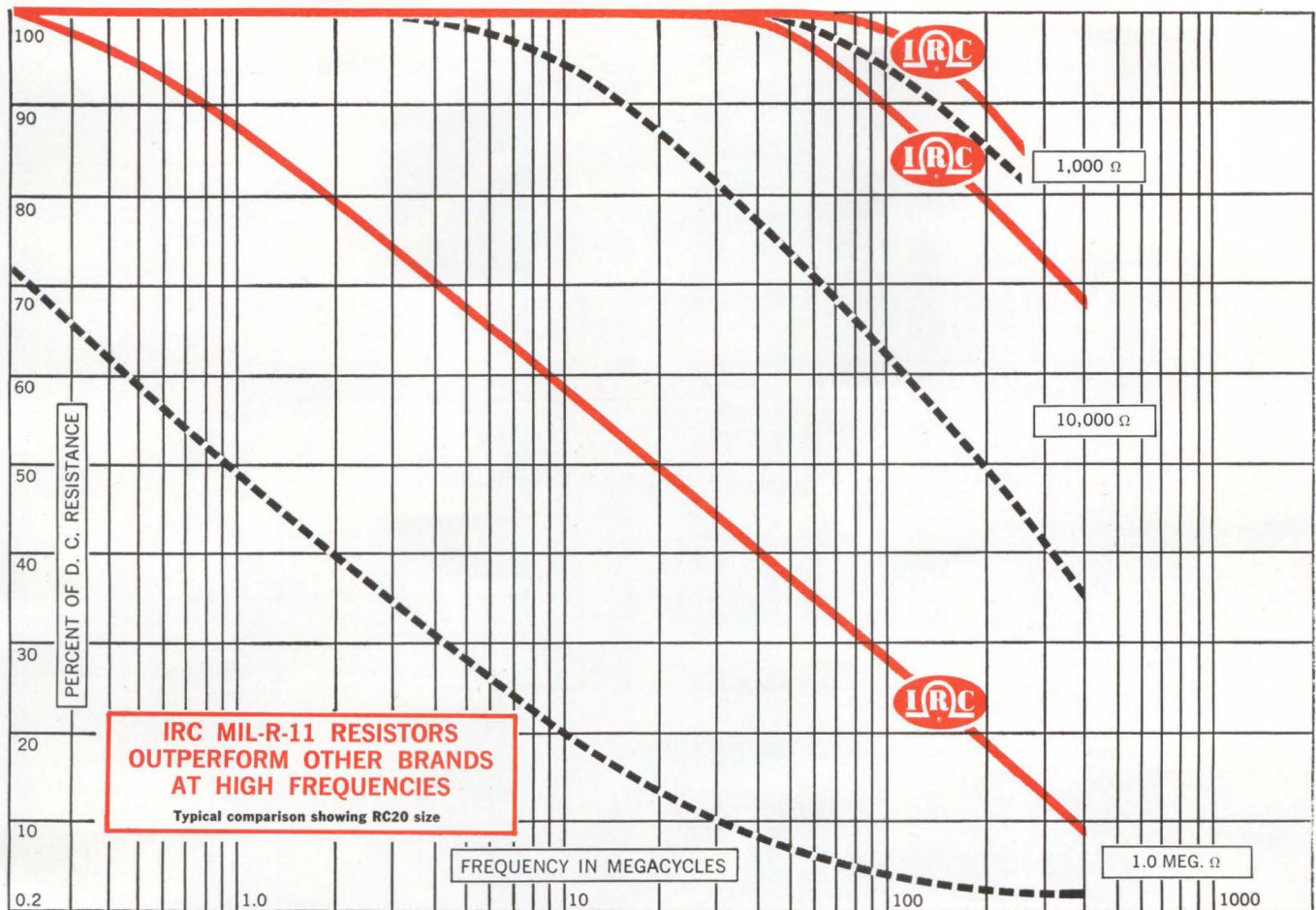

IRC Fixed Composition Resistors give you

SUPERIOR HIGH FREQUENCY CHARACTERISTICS

HERE'S WHY... IRC's resistance element is a film of carbon composition thermally bonded to a glass body. The small cross-sectional area of this exclusive film assures inherently low, shunt capacitance.

All other brands of composition resistors use a slug consisting of carbon granules mixed with organic binders. Due to the large mass of binder material the slug type resistor has a high shunt capacitance.

The best high frequency characteristic is achieved when the ratio of cross-sectional area to the length of the resistor is minimized. IRC's film construction with fewer carbon-binder contacts results in superior performance at high frequencies.

Specify IRC composition resistors for applications where low shunt capacitance, superior pulse shaping and high frequency performance are needed. Write for GBT Bulletin. International Resistance Co., Philadelphia 8, Pa.

PERFORMANCE ADVANTAGES

IRC Type GBT's also provide

- Greater moisture protection
- Lower operating temperature
- Better resistance-temperature characteristics
- Outstanding load life
- Ranges to 100,000 megohms
- Stronger termination
- Weldable leads





HANDLE WITH CARE



MALLORY SETS NEW STANDARDS IN "SOLIDS"

Type TAS solid tantalum capacitor meets or beats all MIL specs for capacitance stability, low DC leakages, low dissipation factor, close tolerances, resistance to environmental exposure. For data on four MIL sizes, from 0.33 to 330 mfd., write for Bulletin 4-40E.

In our plant at Greencastle, Indiana . . . the first, incidentally, built exclusively for tantalum capacitors, and first to fly the Signal Corps RIQAP pennant . . . we've engineered random moisture out of the production line. Laboratory-like precision in control of moisture eliminates one of the most critical variables affecting capacitor life and performance.

Automatic air conditioning keeps plant humidity below 50%, even during the sultriest dog days. Uncased tantalum elements are exposed to this dry air for a maximum of 45 minutes. Between steps in the production cycle, they are kept in desiccators.

Mastery of moisture is typical of our advanced techniques in production and quality control that assure consistently high reliability of Mallory tantalum capacitors. Write or phone for complete data on the Mallory line, the widest in the industry. Mallory Capacitor Company, Indianapolis 6, Indiana . . . a division of P. R. Mallory & Co. Inc.

WET SLUG . . . FOIL . . . SOLID ELECTROLYTE TANTALUM CAPACITORS

P. R. MALLORY & CO. INC.
MALLORY

CIRCLE 66 ON READER SERVICE CARD

Mallory tantalum capacitors delivered from stock at factory prices by these distributors:

- Baltimore, Md.**
Radio Electric Service
- Binghamton, N.Y.**
Wehle Electronics
- Birmingham, Ala.**
MG Electronics & Equipment Co.
- Boston, Mass.**
Cramer Electronics
DeMambro Radio Supply Co.
Lafayette Radio
QPL House, Inc.
- Bridgeport, Conn.**
Westconn Electronics
- Buffalo, N.Y.**
Summit Distributors, Inc.
- Chicago, Ill.**
Allied Electronics Corp.
Newark Electronics Corp.
- Cincinnati, Ohio**
United Radio
- Cleveland, Ohio**
Pioneer Electronics
- Dallas, Texas**
Engineering Supply Co.
Hall-Mark Electronic Corp.
- Dayton, Ohio**
Stotts-Friedman Co.
- Denver, Colo.**
Newark Denver Electronic Supply
- Houston, Texas**
Harrison Equipment Co., Inc.
Lenert Company
- Indianapolis, Ind.**
Graham Electronics
- Kansas City, Mo.**
Radio Lab
- Los Angeles, Calif.**
California Electronics
Kierulff Electronics, Inc.
Lynch Electronics
Radio Product Sales
- Minneapolis, Minn.**
Northwest Electronics Corp.
- Montreal, Que.**
Canadian Electrical Supply Co.
- Muskegon, Mich.**
Fitzpatrick Electric Co.
- Nashville, Tenn.**
Electra Dist. Co.
- Newark, N.J.**
Lafayette Radio
- New York, N.Y.**
Harrison Radio Corp.
Harvey Radio Co., Inc.
Lafayette Radio
Milo Electronics
Terminal Hudson Electronics
- Oakland, Calif.**
Elmar Electronics, Inc.
- Oklahoma City, Okla.**
Radio, Inc.
- Orlando, Fla.**
Hammond Electronics, Inc.
- Ottawa, Ont.**
Wackid Radio-TV Lab.
- Palo Alto, Calif.**
Zack Electronics
- Perth Amboy, N.J.**
Atlas Electronics
- Philadelphia, Pa.**
Herbach & Rademan
Philadelphia Electronics
- Phoenix, Ariz.**
Kierulff Electronics, Inc.
- Pittsburgh, Pa.**
Radio Parts Co.
- Salt Lake City, Utah**
Kimball Electronics
- San Antonio, Texas**
Perry Shankle
- San Francisco, Calif.**
Kierulff Electronics, Inc.
- St. Louis, Mo.**
Olive Electronics
- Seattle, Wash.**
F. B. Connelly Co.
- Springfield, N.J.**
Federated Purchaser, Inc.
- Toronto, Ont.**
Alpha Aracon Radio Co.
Electro Sonic Supply
Wholesale Radio & Electronics
- Tulsa, Okla.**
Engineering Supply Co.
- Washington, D.C.**
Capitol Radio Wholesalers
Electronic Industrial Sales
- White Plains, N.Y.**
Westchester Electronic Supply Co., Inc.
- Winston-Salem, N.C.**
Electronic Wholesalers Inc.

CIRCLE 67 ON READER SERVICE CARD

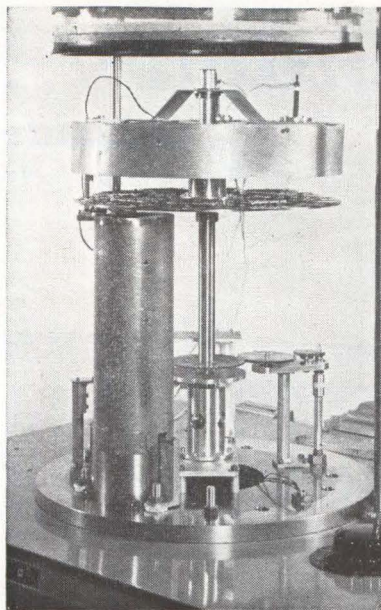

SOLID RADIATION ANGLE OF VAPORIZATION

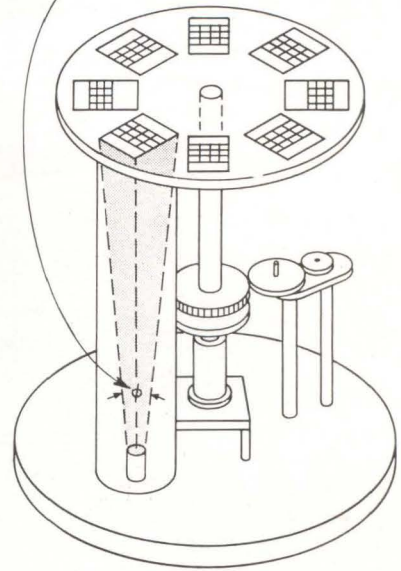

SEQUENTIAL process equipment (left) (vacuum chamber removed) deposits films on successive substrates with separate firings of source material. Diagram (right) shows how substrates are located far enough away from source material to subtend small area of minimum vaporization angle thus getting high depositional accuracy—Fig. 2

lem is maintaining properly scheduled evaporation rates such that the deposited film has optimum characteristics for its intended purpose. The criteria for a chrome gold conductor and soldering pad are adhesion, solderability and conductivity; looked-for in a ni-chrome resistor are resistance, adhesion, temperature coefficient of resistivity and long term stability. These properties, and others, can be achieved through suitable evaporation control involving positional geometries, precision shutoff of processes.

Due to the long mean-free-path of the evaporated molecules at high vacuum, the molecules travel in a straight line similar to light rays. Therefore, masking techniques can be employed to limit deposition to specified areas with high accuracy.

Aside from the afore-described basic problems and requirements, production differs for each thin-film element manufactured by one of two process types in use—"one-shot" and "sequential."

PROCESS TYPES—Both process types were installed so that comparisons could be made to benefit design of future production systems. Considerations such as accuracy requirements, overall cycle time, and power requirements dictate process choice. With both proc-

esses, about 100 thin-film units can be deposited during one pump-down of the evaporator equipment.

With the single-shot process, all required films are deposited in one firing of the source material. The substrates are held in groups on seven mask holders symmetrically arranged around the source using geometry described in Fig. 1. Angular positions shown are imparted to substrates by holder to insure that all substrates are subjected to same deposition rates so as to achieve equal total deposition on each. As can be seen the holder must be located quite some distance from source-evaporating device so as to intercept a suitably large area of the "solid angle of vapor radiation." Because of the necessarily large subtended angle, deposition accuracy of one-shot process is limited. Even so, deviations in thickness over entire deposition area are less than ± 10 percent.

The sequential process uses the same mask holders as the single shot process but these have a horizontal orientation. Eight to ten mask holders are used in the process and are sequentially centered over the source or sources as shown in Fig. 2 to make deposits; the sources being fired each time. Sequential process provides greater deposition accuracy by having substrates located at a greater distance

Exotic Windows...

from 17th Century Leaded
to 20th Century Pressurizing

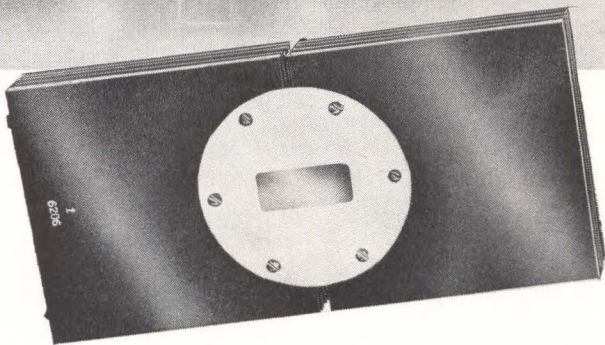

Windows of Old Salem, such as those shown above, were beautifully leaded . . . exotic windows if you please. Today, METCOM, INC., Salem's first aerospace company, produces "exotic windows" of the 20th Century variety . . . electronically known as High Power Pressurizing Windows . . . available in S, C, X and K Bands, and at all other radar frequencies, including Very High Power Handling Versions.

Please write us for full details and listings of our complete line of Pressurizing Windows . . . and 1963 Catalogue.



METCOM INC.

SALEM, MASSACHUSETTS

for better

microwave tubes and devices

so that vapor-radiation area intercepted barely covers each substrate. Device firing source metal also imparts a narrow vapor-radiation angle. Using this approach, deviation of thickness can be controlled to less than ± 2 percent over substrate area. In addition to greater deposition accuracy, the sequential process has lower power requirements, accommodates a greater number of sources but has a longer cycle time than one-shot process.

SILICON MONOXIDE — Silicon monoxide dielectric for capacitors is quickly deposited using single-shot process. Since capacitance is inversely proportional to thickness and proportional to the dielectric constant, these parameters must be carefully controlled. A variation in thickness can occur in one batch or evaporation because of radiation pattern geometry. The substrate holder shape was designed on a theoretical basis to limit this effect to ± 5 percent with tests indicating an actual ± 6 percent. Fig. 1 gives the detailed requirements. To insure good control of thickness from batch to batch, the evaporation rate is monitored and controlled using a momentum gage and the process heating time is fixed. The momentum gage balances the torque created by the silicon monoxide vapor impinging on a vane attached to a D'Arsonval meter movement against the torque produced by a known current. Evaporation rate is increased until a null balance occurs. The silicon monoxide is evaporated from an Allen Jones # AJ2 Drumheller heating device in the presence of oxygen which helps produce consistent values of dielectric constant. Substrate heating is set at its degree C temperature. Aluminum electrodes are used with the silicon monoxide dielectric and also evaporation deposited. The electrode, dielectric, and counter-electrode masks all differ and each one-shot evaporation and deposition is done on separate pump-downs. Heating current applied to source material controls deposition rate.

TANTALUM CAPACITOR — The sequential technique, with electron bombardment for heating, is used for producing tantalum-dielectric capacitors. In this system a base electrode of aluminum uses the

same masking pattern as the tantalum dielectric. Accordingly, during the same pump-down, aluminum and tantalum are deposited sequentially until all groups of substrates are completed. The thickness of the tantalum does not affect the value of capacitors; this is determined by the subsequent anodizing process which converts the tantalum to tantalum oxide. The capacitor is completed by the addition of a gold counterelectrode using the gold chrome process.

For the source material a tantalum slug is placed on one crucible and tightly rolled aluminum wire on another crucible.

CHROME GOLD CONDUCTOR—

Since the thickness of the chrome gold conductor or pad is not critical, the shorter cycle single shot system was selected to increase production rate (see Fig. 1). Two adjacent metal sources, gold and chrome (with a small amount of gold added for wetting action to increase heat transfer) are used. Sources are fired so that the final film consists of an initial chrome layer followed by a gradual blending of chrome and gold with a final coating of pure gold. The blended alloy has excellent adhesion: a tensile stress of 2,500 psi can be obtained reliably; in some tests, the adhesion was greater than the cohesion of the glass test substrate. A nominal thickness of 7,000 Angstroms provided good conductivity and excellent joinability to wiring by soldering or welding.

NICHROME RESISTOR—Nichrome is probably the most useful material for intermediate values of resistance.

Sequential evaporation is used. A nichrome ball is placed on a water-cooled, insulated crucible, and heated by electron bombardment: Electrons emitted by a tungsten filament are accelerated by the high potential of the crucible and source material. The concentration of these high-energy electrons melts and evaporates the nichrome. Evaporation rate is established by the bombardment power. However, the resistance value is controlled by stopping deposition automatically upon achieving the desired value of film resistance using a bridge-circuit control system.

NOW!
RECORD VOLTS, OHMS, MILLIAMPS
 with **ONE RECORDER**
 ... **NO EXTRAS!**



ONLY
\$595
 COMPLETE

New Bausch & Lomb V.O.M.-5 RECORDER

... an all-new, complete 5-inch strip-chart recorder that breaks all precedent in the field ... brings you the finest features of potentiometric recorders for one low price. Compare these exclusive advantages, all these "extras" at no extra cost, with any other recorder in its class.

- Five voltage ranges, 10 millivolts to 500 volts D.C.—full scale deflection.
- Six linear ohms scales, 1-to-100,000 ohms full scale, with zener diode D.C. supply.
- Four D.C. current ranges—10 microamperes to 100 milliamperes.
- Off balance input impedance—over 10 megohms.
- Five chart speeds, 400-to-1 range.
- Event marker, with interchangeable pens.
- Function switch with mechanical pen letdown.
- Operates in flat, 30° tilt, or wall-mounted position.
- Compact—only 4¾" x 14½" x 11¾".
- Portable—only 16 lbs.

And more. Lots more! Mail the coupon now for the whole story on this new 5-speed recorder with versatility-plus!

BAUSCH & LOMB

BAUSCH & LOMB INCORPORATED
 61442 Bausch Street
 Rochester 2, N. Y.

Please demonstrate the V.O.M.-5 Recorder at my convenience.
 Send Recorder Catalog D-2032.

Name Title

Company

Address

City Zone State

Automate With This Versatile Counter

Same unit counts, stores, reads-out, and controls remote digital indicator

CONVENTIONAL electromechanical counters usually display their total count and that's it; this one incorporates a 10-line electrical output for controlling remote indicators or feeding parallel data to similar counters. The built-in printed circuit 10-line switch can also be hooked up to the counter's own drive coil to motor the display-drum to the value of incoming parallel information. Indirect mechanical drive enables an electrical drive pulse to store energy by cocking a spring; at end of drive-pulse the

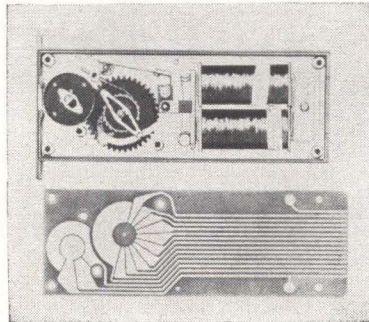

spring ratchets the counter round one step. This technique provides rapid switching action, completing the rotor travel in about 2 milliseconds as shown in the timing diagram.

Printed circuit techniques developed by the company have achieved low contact resistances of less than

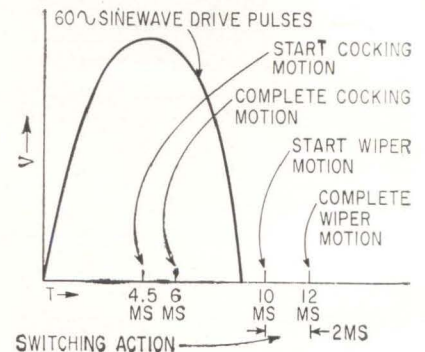

0.1 ohm even after 100 million operations, while use of modern plastic materials confer lubrication-free life on the mechanical parts. The unit is priced at around \$35 and comes from Durant Manufacturing Company, Milwaukee 1, Wisconsin.

CIRCLE 301, READER SERVICE CARD

Revamped 12AT7 Handles 3/4 Amp

NEWLY DESIGNED vacuum tube designated A2900 is intended as a replacement for the 12AT7 in critical applications where the new tube's tightly controlled parameters reduce the adjustment and maintenance involved. Owing to the A2900's greatly increased plate-current during pulsed-operation, the new tube also opens up applications in radar and related fields for pulses of short duration and high power.

The illustration shows how little the characteristics drift during the life of sample tubes tested. The company, Calvert Electronics Inc., 220 East 23rd Street, N. Y. 10, N. Y., backs up its claim for tightly controlled specs and minimum life of 10,000 hours by issuing a warranty for purchases of 10 tubes or more. Besides the continuous duty performance of this tube, operation in the pulsed mode enables it to handle $\frac{3}{4}$ amp pulses

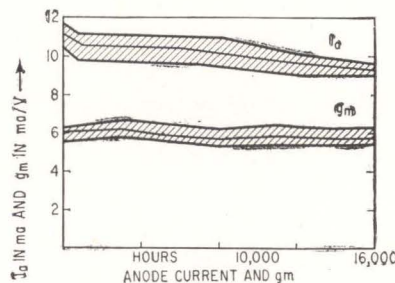

in blocking oscillator and similar circuits. Maximum pulse duration is 5 microseconds, peak plate voltage is 1,000 volts. (302)

Precision Limit Switch

MODEL ASM45 limit-switch triggers an internal scr and self-contained relay when sensing-coil-current differs from a predetermined value by as little as one microampere. Oper-

ation is in the zero-to-1.15 milli-amp sensing range but the low-drift magamp input stage withstands 100 times overload without damage. The unit operates on a differential principle with currents in reference and 75 ohm sensing coil cancelling for zero response.

Individual screwdriver adjustments alter sensitivity ($1 \mu\text{a}$ to 1.15 ma) and hysteresis (2 to 150 μa) for independent pick-up and drop-out levels. Feeding both the sensing and reference winding from tachogenerator outputs enables the unit to detect a 1 percent speed difference for tachometers with 1 milli-ampere full scale output. Other uses are in monitoring temperature, pressure and many other industrial variables where the appro-

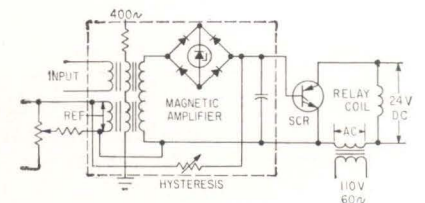

ELECTRICAL INTEGRATORS

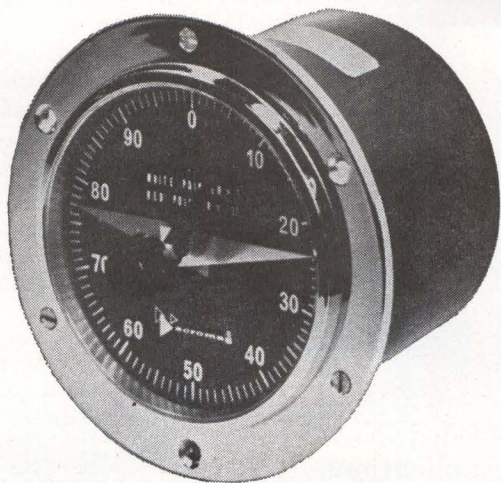

for...

- GAS CHROMATOGRAPHY
- COULOMETRIC TITRATION
- CONVEYOR BELT WEIGHING
- MASS FLOW RECORDING
- SUN LIGHT RECORDING
- NUCLEAR DOSIMETER
- ELECTRO-PLATING ANALYSIS
- BATTERY EVALUATION
- LABORATORY APPARATUS

Request Technical Data No. 90

A new way of integrating electrical signals. If your signal is a DC voltage, or can be changed into one, these new units integrate it to 0.5% or better accuracy. Delivery is from stock. Price only \$139.00; quantity discounts.



acromag®
INCORPORATED

15360 TELEGRAPH ROAD - DETROIT 39, MICHIGAN
Telephone: 538-4242, Area Code 313

TELETYPE: 313-538-4536

CIRCLE 202 ON READER SERVICE CARD

THE OKI LADDERTRON®

This MM-Wave Generator Produces 15 Watts C.W. at 34 and 50 KMC

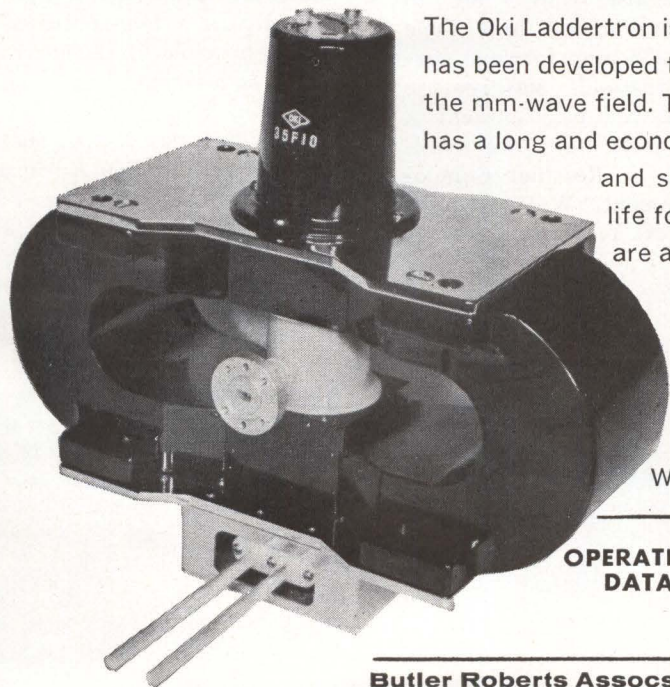

The Oki Laddertron is a new high power millimeter-wave generator which has been developed to meet the needs of research and development in the mm-wave field. This double-ladder Klystron is extremely stable and has a long and economical operating life. Its unique ladder construction and specially designed electron gun system give it long life for such high power output. Frequency and output are as stable as a frequency standard. It maintains constant output level throughout its wide 1.5 KMC tuning range. And, the Oki Laddertron operates from conventional power units at 1.8 KV, eliminating the need for special and costly power supplying equipment.

Write, on your letterhead, for further information.

OPERATING DATA

Type Number	35F10	50F10
Heater	6.3 V, 1-2 A	6.3 V, 1-2 A
Resonator	1850 V, 110 mA	2140 V, 120 mA
Tunable Frequency	33.2-34.8 KMC	49.0-51.0 KMC
Output	15 W, 34 KMC	15 W, 50 KMC
Electronic Tuning	40 MC	40 MC

Butler Roberts Assocs., Inc.
A Subsidiary of
OKI Electronics of America
500 SE 24 St. Ft. Lauderdale, Fla. 523-7202
202E, 44 St., N.Y. MU 2-2987

OKI
electric industry
co., Ltd. TOKYO JAPAN

10, Shiba Kotohiracho,
Minato-ku, Tokyo, Japan
Tel. 501-3111
Cable: OKIDENKI TOKYO

NOW!...

read diode and zener characteristics at operating temperatures

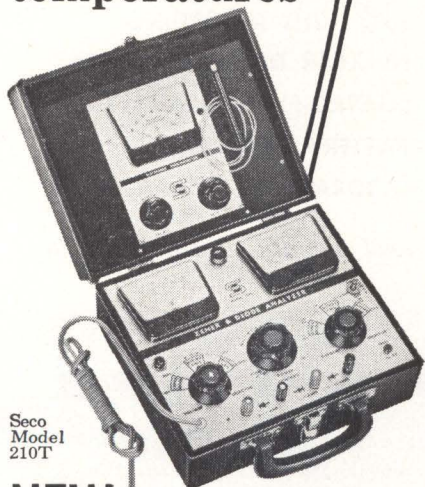

Seco Model 210T

NEW!... SECO DIODE AND ZENER ANALYZER

- 0-1-10-30 amp forward voltage drop test
- 0-150 V and 0-1500 V reverse current leakage test
- 0-30 V and 0-300 V zener saturation knee test
- -20° to 160° C temperature test

The Model 210T tests signal and power diodes from 20 MA to 30 amps and from 0-1500 volts. Zener diode test range is from a fraction of a volt to 300 volts and up to 100 MA. Selenium rectifier testing range is from a fraction of a volt forward drop to 300 volts. Temperature readings are continuous. This analyzer operates on standard 110 V 60 cycle AC current with two 1.5 V "C" cells powering the thermometer.

MODEL 210T \$274.95 NET analyzer and thermometer in one unit.



SECO MODEL 212 ELECTRONIC THERMOMETER

Thermistor probe in unique bridge circuit gives accurate, continuous readings from anything it touches—-20° to 160° C range. Sensing tip is heat-insulated—can be held in hand or fastened to unit under test.

MODEL 212 \$79.50 NET thermometer only

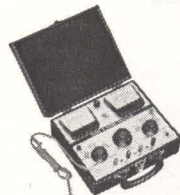

SECO MODEL 210 DIODE AND ZENER ANALYZER

Gives you all features of Model 210T except temperature test. • Tests zener diodes • Tests silicon diodes • Tests germanium diodes • Tests selenium rectifiers

Five sources of power provide over a dozen fully variable test voltages and currents—even a manually reset over-current relay. A practical test set for laboratory and engineer's use—or for incoming stock inspection.

MODEL 210 \$199.50 NET analyzer only

SECO ELECTRONICS, INC.
1213 S. Clover Drive
Minneapolis 20, Minn.

appropriate transducer is available. The units are manufactured by Airpax Electronics Inc., Seminole Division, Ft. Lauderdale, Fla.

CIRCLE 303, READER SERVICE CARD

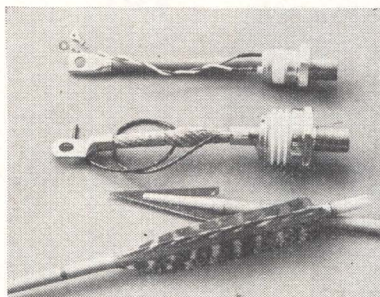

Fewer SCR's Needed Now For High-Power Applications

NEW SCR with current rating of 300 amperes and reverse voltage capability of 400 volts means that fewer individual scr's need be paralleled for high-capacity variable supplies. These scr's, which are said to have the highest power rating in the industry, are intended for replacing thyratrons, ignitrons, saturable reactors, contactors, and other control gear.

Maximum forward current rating of scr Type 6RW71 is 470 amps, peak one-cycle current is 5,500 amps, while storage and operating temperatures are from -40C to 125C. A lower-current unit Type C80 handles 235 amp forward current and withstands 800 reverse volts; its one-cycle peak current is 3,500 amps. Both units are available from G. E. Rectifier Components Department, West Genesee St., Auburn, N. Y. (304)

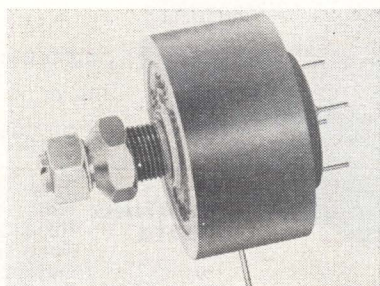

Phase-Shift Capacitor Trimmer

PHASE-SHIFTING capacitor provides highly accurate phase-trimming in phase lock circuits. Fixed phase

trim in circuit is easily adjusted by screwdriver and locked to prevent accidental rotation. Designated Phasetrim model P21A02, the compact unit is housed in a glass filled diallyl phthalate case. All units are temperature cycled to improve stability. Capacitance as measured between one of four input plates to the common output plate, is a minimum of 1.6 pf to a maximum of 2.7 pf. Capacitance is variable as a function of phase-trim adjustment. Nilsen Mfg. Co., P. O. Box 127, Haines City, Fla. (305)

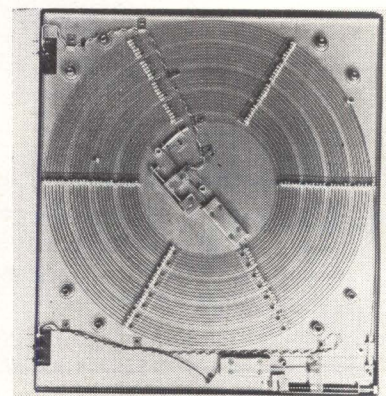

Delay Line Can Store 7,000 Bits

LOW-COST standard magnetostrictive delay line, model SD-4, can store as many as 7,000 bits at a digit rate of 1.5 Mc in a non-return-to-zero mode. It provides its large storage capacity in a compact case measuring 11½ in. by 10½ in. by 7/16 in. The delay line may also be operated at a digit rate of 750 Kc in a return-to-zero mode as well as 1.5 Mc in a non-return-to-zero mode. Price is \$125. Sonic Memory Corp., 494 Oak St., Copiague, N. Y. (306)

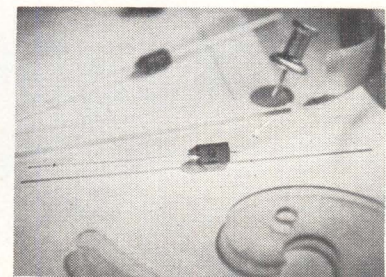

Zener Diodes of Cold Case Design

TYPE ZA zener diodes of cold case design incorporate the same zener

diode cell used in hermetically sealed units and meet the electrical and environmental requirements of computers, commercial and entertainment applications. Transfer molding techniques are used in manufacturing the high-strength, moisture-resistant package. Case length is 0.375 in. max; diameter is 0.200 in. max. Power rating is 1 w. Standard tolerances are 20, 10 and 5 percent. Mallory Semiconductor Co., DuQuoin, Ill. (307)



Cold Chambers for General Purpose Use

LINE of general purpose cold chambers employ the latest technology in thermoelectric cooling. The GPC series are available in several models, all of which operate with an input current of 10 amp or less. The model pictured will pump a maximum of 28 w or 95 Btu's in a 74 F ambient and can attain cold temperatures as low as 3 F in room temperature ambient. Its interior measures 5½ in. by 5½ in. by 5¼ in. Scientific Columbus, Inc., 840 Kinnear Road, Columbus 12, O. (308)

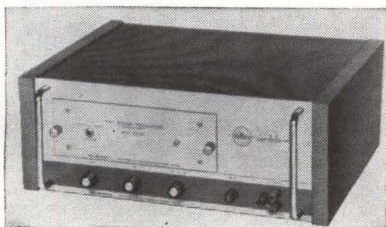

A-C Power Amplifier Covers Wide Band

NEW a-c power amplifier with 160 v-a power output, 45 cps to 10 Kc frequency range, is announced. Model 1160 features special circuitry for improved amplitude stability, load regulation and low distortion. Typically the amplitude regulation is less than ±0.25 percent for 10 v line change. Unit is a regulated wide band amplifier with

NEW!

SENSITIVE VIDEO BALLANTINE VTVM

**Measures 100 μV to 100V
at frequencies 10 cps to 6 Mc**

**Gives you 2% accuracy
of reading over the
entire scale – more
accurate over lower half
of the scale than a
linear meter rated at
1% of full scale**

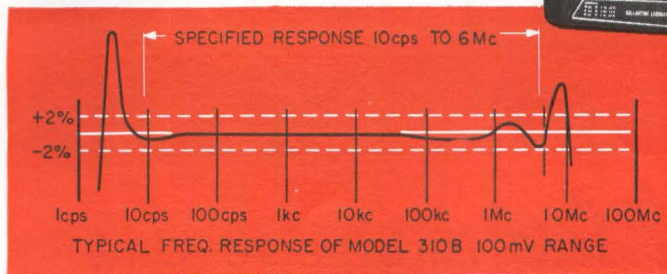

Model 310B
Price: \$250

Ballantine's Model 310B Video VTVM is a general purpose instrument for use over an extremely wide range of both voltage and frequency. A newly improved version of the popular Model 310A, it gives you these benefits: (1) a wider frequency range; (2) a larger indicating meter; (3) greater accuracy; (4) increased feedback and longer life; (5) greater sensitivity; (6) provision for choice of co-axial or binding post input; (7) use as a 60 db amplifier, 10 cps to 6 Mc; and (8) improved serviceability.

SPECIFICATIONS

Voltage Range.....100 μV to 100V (to 1,000 V or 10,000 V rms with optional accessories)	20 cps to 2 Mc; 3%, 10 cps to 4 Mc; 5%, 10 cps to 6 Mc
Frequency Range.....10 cps to 6 Mc (3 db bandwidth is 2 cps to 10 Mc)	Null Detector Mode.....Sensitivity 30 μV
Accuracy AT ANY POINT ON SCALE, ANY VOLTAGE. Error does not exceed 2%,	Scales.....One logarithmic voltage scale, 0.9 to 11 and one linear db scale, 0 to 20
	Input Impedance.....2 MΩ shunted by 15 or 25 pF

Write for brochure giving many more details



— Since 1932 —
BALLANTINE LABORATORIES INC.

Boonton, New Jersey

CHECK WITH BALLANTINE FIRST FOR LABORATORY VACUUM TUBE VOLTMETERS, REGARDLESS OF YOUR REQUIREMENTS FOR AMPLITUDE, FREQUENCY, OR WAVEFORM. WE HAVE A LARGE LINE, WITH ADDITIONS EACH YEAR. ALSO AC/DC LINEAR CONVERTERS, CALIBRATORS, WIDE BAND AMPLIFIERS, DIRECT-READING CAPACITANCE METERS, AND A LINE OF LABORATORY VOLTAGE STANDARDS 0 TO 1,000 MC.



FOR SUPER-FINE
CUTTING OF HARD,
BRITTLE MATERIALS...

THE *S.S. White* Airbrasive® Unit

The Airbrasive is *not* the way to open your breakfast egg. But it is often the *only* way to cut many extremely hard, fragile materials.

It would pay you to look around your production line or laboratory to see where you can use the Airbrasive. Any tool that can make tricky cuts like these in such a fragile object as an empty egg-shell can surely do jobs for you that you previously thought were impossible.

The secret of its unique ability lies in a finely controlled stream of microscopic abrasive particles gas-propelled through a precise nozzle. This stream cuts or abrades or cleans *without shock, heat, or vibration.*

Use it to make cuts as fine as 0.005" . . . remove surface coatings . . . adjust microminiature circuits . . . debur tiny parts . . . and many more delicate tasks. The cost is low. For under \$1,000 you can set up your own Airbrasive cutting unit.

Send us samples of your "impossible" jobs and let us test them for you at no cost.

WRITE FOR
BULLETIN
6006.



S S. WHITE INDUSTRIAL DIVISION
Dept. EU, 10 East 40th St., New York 16, N. Y. • Telephone 212 MU 3-3015 collect.

S.S. White INDUSTRIAL
AIRBRASIVE

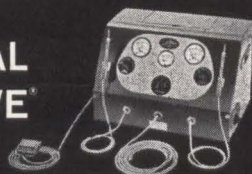

plug-in modules to permit multiple a-c power source applications. Six different plug-in modules include variable frequency, fixed frequency and frequency standard oscillators for stable input to the amplifier. Elin Division, International Electronics Research Corp., 135 W. Magnolia Blvd., Burbank, Calif. CIRCLE 309, READER SERVICE CARD

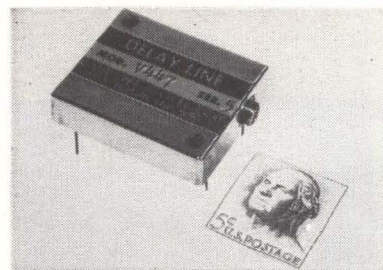

Variable Delay Lines For P-C Mounting

ULTRAMINIATURE series of variable lumped constant delay lines are announced. Representative of the series is model V447 illustrated, which provides a delay range of 0 to 55 nsec in a case only 1 in. by $\frac{1}{8}$ in. by $1\frac{1}{4}$ in. long. Impedance is 140 ohms. Output rise time is 15 nsec. Attenuation is less than 10 percent and resolution is less than 5 nsec. Temperature stability is better than 50 ppm/deg C. Computer Devices Corp., 6 W. 18 St., Huntington Station, N. Y. (310)

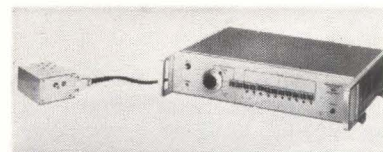

Servo Programmer Is Transistorized

SERVO PROGRAMMER, the DY-2307A, is available to assist in accurate remote, local or preset positioning of rotating shafts. Typical applications include programming of microwave attenuators and signal generators, and kits are available to mechanically adapt the instrument for these purposes. The DY-2307A is equally suitable for driving any rotating shaft with less than 40 oz-in. load. The instrument incorporates a control amplifier package and remote servo-drive unit which attaches directly to the

instrument to be driven. The drive unit may be operated up to 1,000 ft away from the control amplifier. Dymec, a division of Hewlett-Packard Co., 395 Page Mill Road, Palo Alto, Calif. (311)

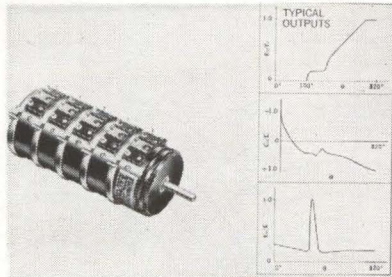

Precision Pots of Conductive Plastic

HIGH RELIABILITY precision pots with practically any required non-linear output, from simple to highly complex functions, are offered in a complete range of sizes and configurations. In military, industrial and commercial controls and instrumentation where long life, infinite resolution, high reliability and precision are required, the new units meet close conformity requirements. Design and manufacturing techniques used for the units permit the use of less complicated circuitry and fewer associated components, resulting in increased system reliability and reduced space and weight. Markite Corp., 155 Waverley Place, N. Y. C. (312)



Circuit Breakers Are Ambient Insensitive

TRIP-FREE, light weight (2 oz), ambient insensitive, magnetic circuit breaker with either push-pull or toggle actuation plus an optional, built-in auxiliary indication circuit is announced. The Klixon 2 MC (toggle) and 3 MC (push-pull) is now being used in data processing, power supplies, communica-

RV4

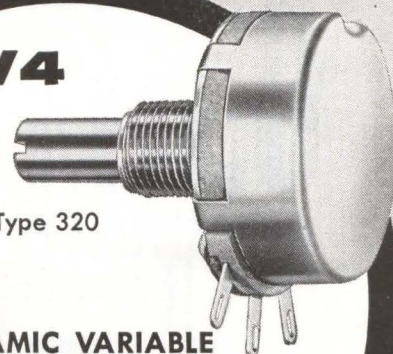

Type 320

3-WATT CARBON-CERAMIC VARIABLE RESISTOR AT THE 2-WATT PRICE

Type 320 variable resistor (1 $\frac{1}{16}$ -inch dia.) offers a full 3-watt rating at 70°C derated to zero at 150°C. Resistance range from 250 ohms through 2.5 megohms.

CTS Type 320 and Type 300

EXCEED

Styles RV4 and RV6

MIL-R-94B

Characteristic Y. Excellent Heat Sink Due to Carbon-Ceramic Element Qualities. Completely Enclosed Construction.

RV6

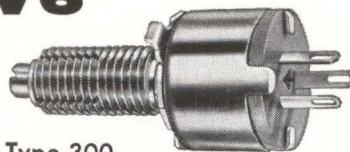

Type 300

$\frac{3}{4}$ -WATT CARBON-CERAMIC VARIABLE RESISTOR AT THE $\frac{1}{2}$ -WATT PRICE

Type 300 variable resistor ($\frac{1}{2}$ -inch dia.) offers $\frac{3}{4}$ -watt rating at 70°C derated to no load at 150°C. Resistance range from 100 ohms through 2.5 megohms.



CTS of Berne, Inc., Berne, Indiana

T.M. subsidiary of **CTS CORPORATION • ELKHART, INDIANA**

West Coast: Chicago Telephone of California, Inc., 1010 Sycamore Ave., So. Pasadena, Calif.
In Canada: CTS of Canada Ltd., Streetsville, Ontario

WHY SETTLE FOR LESS?

0.01%

ACCURATE

SIZE 23 RESOLVER



Type 23RV4a1

Here's a top rated resolver that's priced surprisingly low. So why settle for less than Ford Instrument's highly accurate Size 23 Resolver... the resolver that exceeds MIL-E-5272A.

SPECIFICATIONS:

- Maximum Functional Error (over 360° of shaft rotation)...0.01% of input voltage at maximum coupling
 - Maximum Total Null Voltage... 1 mv/volt input maximum
 - Maximum Interaxis Error (rotor) ... 1.5 minutes
 - Maximum Interaxis Error (stator) ... 1.5 minutes
 - Maximum Variation of Transformation Ratio (with input voltage from 6-18 volts with 12 volts input as reference) ... 0.03%
 - Maximum Variation of Transformation Ratio (with input voltage from 0.3 to 6 volts) ... 0.02% of 6 volts
- 0.025% accuracy available in size 15
Bulletin FR 62-1 gives full specifications. It's yours for the asking. Write:

FORD INSTRUMENT CO.

Division of Sperry Rand Corporation
31-10 Thomson Ave., Long Island City 1, N. Y.

tions, panel boards, electrical and electronic test equipment, aircraft, missile and ground support equipment. Metals & Controls Inc., a corporate division of Texas Instruments Inc., Attleboro, Mass.

CIRCLE 313, READER SERVICE CARD



R-F Oven Offers High-Speed Heating

BENCH-TYPE, portable r-f oven is capable of heating liquid epoxy resins and similar insulating materials in a matter of seconds. The rapid r-f heating may be used to heat heavily filled compounds to an ideal pour viscosity for void free casting as well as accelerate cure times for long pot life resins. Features include adjustable electrode, cycle timer, safety-door inter-lock and ease of operation. Price is \$495. Empire Research Corp., 31-2 Ontario St., Cohoes, N. Y. (314)

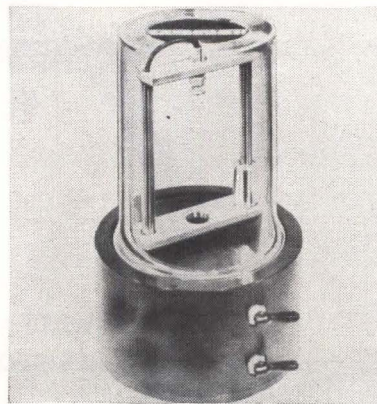

Vacuum Chamber Tests Solid State Detectors

Low cost model VC-10 vacuum chamber for testing solid state detectors and alpha sources provides an infinite number of source to detector distances from 0 to 3½ in. Detector and source insertion and removal is simple and quick. Vacuum enclosure is a stainless steel bell jar. Venting to vacuum and

Acoustical Components of Superior Quality

JAPAN PIEZO supplies 80% of Japan's crystal product requirements.

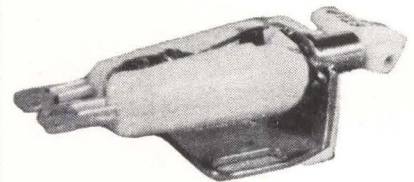
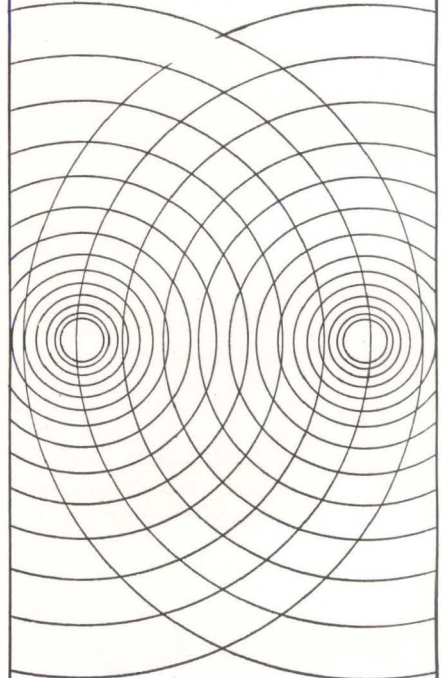

STEREO CARTRIDGE

Crystal — "PIEZO" Y-130
X'TAL STEREO CARTRIDGE

At 20°C, response: 50 to 10,000 c/s with a separation of 16.5 db. 0.6 V output at 50 mm/sec. Tracking force: 6±1 gm. Compliance: 1.5×10⁻⁶ cm/dyne. Termination: 1MΩ + 150 pF.

Write for detailed catalog on our complete line of acoustical products including pickups, microphones, record players, phonograph motors and many associated products.



JAPAN PIEZO ELECTRIC CO., LTD.

Kami-renjaku, Mitaka, Tokyo, Japan

CIRCLE 203 ON READER SERVICE CARD
June 7, 1963 • electronics

atmosphere is separately valved for reliability. Nuclear Diodes Inc., 1640 Old Deerfield Road, Highland Park, Ill. (315)

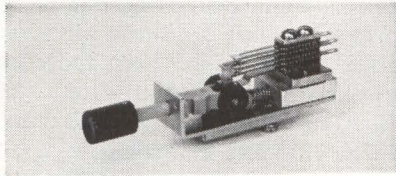

Push-Button Switch Is 3/4-Inch Wide

SERIES 761 push-to-lock, push-to-release push-button switch is designed for convenient switching of multiple circuits in electronic and communication equipments for commercial and military applications. Construction features a roller mounted plunger and positive locking mechanism for smooth, reliable operation. Width is 3/4 in.; depth behind panel, 2 1/2. Donald P. Mossman, Inc., P. O. Box 265, Brewster, N. Y. (316)

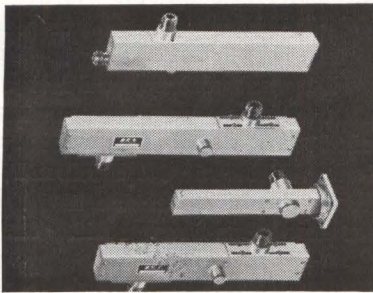

Frequency Multipliers Are Factory Timed

OPERATING at frequencies from 125 Mc to 10 Gc, these multipliers may be used as single units or cascaded to provide any multiplication to customer's desired frequency. Standard doublers and triplers with typical 60 percent efficiency are available now at power levels up to several watts and spurious rejections of 20 db to 30 db. Units are factory tuned to customer's exact frequency requirements. Lel, Inc., 75 Akron St., Copiague, N. Y. (317)

Lacing Tapes Are Burn-Proof

BURN-PROOF TAPES, constructed in a flat braid, are made of pure Da-

electronics • June 7, 1963

Magitran® Magnetic/Transistor DC Lab Power Supplies – Popular “Work Horses” – Now at New Low Prices

Well-known ERA Magitran DC Laboratory Power Supplies, with their unmatched reputation for reliability, are now available at new low prices. These “work horses” combine the rugged properties of magnetic regulators with the fast response characteristics of transistor regulators (see diagram).

Magitrans are in use today by the thousands, providing tight regulation, low ripple and other essential features in an uncomplicated, easy-to-maintain, trouble-free package. Write today for new literature.

Model No.	Voltage VDC	Current Amps	Regulation Line	Regulation Load	Ripple RMS	Price FOB Factory
203M *	10-300	0-0.2	±0.05%	0.05%	0.01%	\$295.
TR36-4	0-36	0-4	±0.02%	0.05%	0.005%	\$340.
TR36-8	0-36	0-8	±0.02%	0.05%	0.005%	\$445.
TR36-12	0-36	0-12	±0.02%	0.05%	0.005%	\$495.
TR36-20	0-36	0-20	±0.05%	0.1%	0.005%	\$675.
TR36-30	0-36	0-30	±0.05%	0.1%	0.01%	\$885.
TR36-50	0-36	0-50	±0.05%	0.1%	0.01%	\$1635.
TR160-1	10-160	0-1	±0.05%	0.05%	0.01%	\$315.
TR300-1	150-300	0-1	±0.05%	0.1%	0.02%	\$515.

Note: Add \$30.00 and suffix M for meters.

* Includes meters.



Also DC Power Modules, Inverters, Converters, Frequency Changers, Special Test Equipment.

ELECTRONIC RESEARCH ASSOCIATES, INC.

Dept. E-6, 67 Factory Place • Cedar Grove, N. J. • CEnter 9-3000

SUBSIDIARIES: ERA Electric Co. • Advanced Acoustics Co. • ERA Dynamics Corp. • ERA Pacific, Inc.

WHICH DEFLECTION YOKE ? FOR YOUR DISPLAY

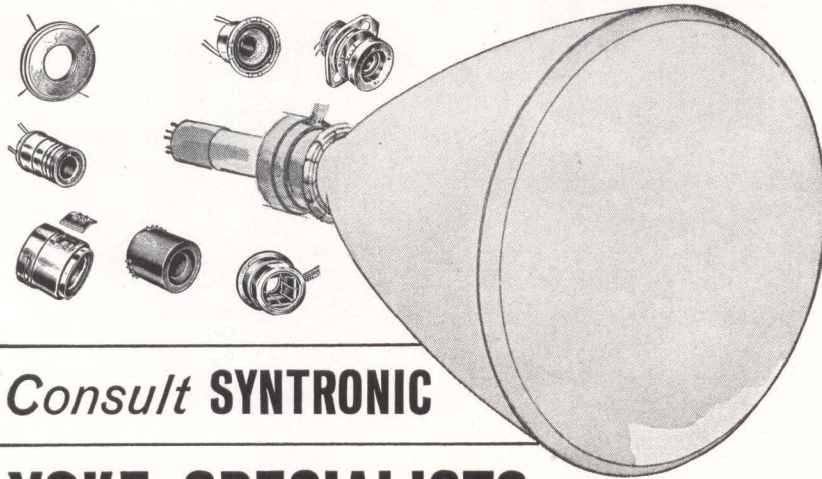

Consult **SYNTRONIC**

YOKE SPECIALISTS

Syntronic's team of experts knows more about yoke design, engineering and quality control than anyone else. A solid 10-year record of leadership—acknowledged throughout the industry. Benefit from it.

syntronic INSTRUMENTS, INC.
100 Industrial Road, Addison, Illinois
Phone: Kingswood 3-6444

CIRCLE 204 ON READER SERVICE CARD

COMINCO

HIGH PURITY METALS
AVAILABLE FORMS

clip and save

Product	ALUMINUM	ANTIMONY	ARSENIC	BISMUTH	CADMIUM	GOLD	INDIUM	LEAD	SILVER	TIN	ZINC
BARS	✓	✓	✓	✓	✓	✓	✓	✓	✓	✓	✓
SHEETS	✓				✓	✓	✓	✓	✓	✓	✓
WIRE	✓				✓		✓	✓		✓	✓
POWDER		✓	✓	✓	✓	✓	✓	✓	✓	✓	✓
SHOT		✓		✓	✓	✓	✓	✓	✓	✓	✓
ROD	✓			✓	✓		✓	✓	✓	✓	✓
RIBBON							✓	✓			
PRE-FORMS	✓				✓	✓	✓	✓	✓	✓	✓
SALTS					✓		✓				

COMINCO PRODUCTS, INC.

electronic materials division

933 West Third Avenue, Spokane 4, Washington
Phone Area Code 509 RI 7-7103 • TWX 509 328-1207

3402

ron fibers and meet or exceed all requirements for MIL-T-713A. The burn proofing exceeds requirements of ASTM-D626-55T. Two types of tape are provided—Stur-D-Lace F1-H is impregnated with a flame proof fungistatic synthetic rubber finish, while Stur-D-Lace-R is impregnated with a flameproof fungistatic vinyl finish. Both types are essentially stable from -100 to 350 F. Gudebrod Bros. Silk Co., Inc., 12 S. 12th St., Philadelphia 7, Pa.
CIRCLE 318, READER SERVICE CARD

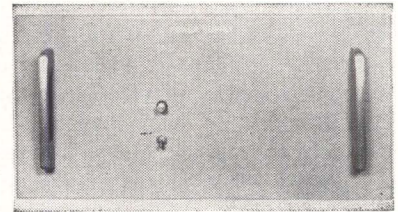

Regulated Supply Provides 26 V D-C

REGULATED 1-v power supply, type NDO4, is a full-wave rectifier type which provides an electronically regulated output of 26 v d-c. Unit is particularly adaptable to provide controlled power to a reactor safety system network including logic elements, annunciators, and relays or other applications which require a reliable regulated 1-v power output. General Electric Co., Nuclear Electronic Products Section, 175 Curtner Ave., San Jose, Calif. (319)

X-Band Klystron Used in F-M Systems

MODEL R9687 klystron has an improved electron gun design which imparts complete freedom from ion oscillation. This is important in frequency-modulated systems, where such oscillation results in spurious modulation of the output. This low power klystron operates in an external resonator and, in suitable cavities, is useful in the frequency range 6.5 Gc to 12 Gc. Fixed-frequency or tunable cavities may be employed and these may be either of the radial-line or coaxial-line type. Operators of f-m microwave and tv links will find the new tube an ideal local oscillator. EMI Electronics Ltd., Hayes, Middlesex, England. (320)



ROTARY SWITCHES

TABET U. S. Patent 2,841,660

- For Critical Reliability Applications. Meet MIL-S-22710
- Quick changing of programs, configurations, circuits.
- Maintenance problems completely eliminated by unique 5-second wafer replacement models.



1 3/4" x 1 1/2" Rotary Selector Switch, Series RS15. Manually (illustrated), motor or solenoid operated.



2 1/4" x 2 3/4" Rotary Selector Switch, Series RS21. Solenoid, manually or motor operated.

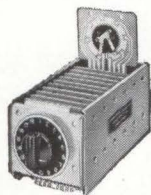

3" x 2 1/2" Rotary Selector Switch, Series RS30. Manually (illustrated), solenoid or motor operated.



4" x 4" Rotary Selector Switch, Series RS40. Motor, manually or solenoid operated.

CHICAGO DYNAMIC INDUSTRIES, Inc.



PRECISION PRODUCTS DIVISION
1725 Diversey Blvd., Chicago 14, Illinois
Phone: WEllington 5-4600

CIRCLE 205 ON READER SERVICE CARD



NEW

Reduce production cabling time with . . . PANDUIT'S PNEUMATIC CABLING TOOL*

Insert strap . . . touch valve . . . the STA-STRAP is tensioned, trimmed flush and the cut-off portion automatically ejected. Tool weighs less than one pound and needs no air regulator. No twisting of strap required. For further information, write Panduit Corporation, 17301 Ridgeland Avenue, Tinley Park, Illinois. *Pat. applied for.



CIRCLE 206 ON READER SERVICE CARD



Coils for Contact Capsules

1 to 5 Reeds
.095 — .215 dia.
6 to 48 V.D.C.
Lead or Pin Term.
Also Available with Reeds.

Write for Bulletin and Prices

ELECTRICAL COIL WINDINGS

Wire sizes #6 to #56, Classes A, B, F and H. Complete engineering service available.

Coto-Coils

COTO-COIL
COMPANY
INC.

65 Pavilion Avenue, Providence 5, R. I.

CIRCLE 207 ON READER SERVICE CARD
electronics • June 7, 1963

*The Notes have not been and are not being offered for sale to the public.
This announcement appears as a matter of record only.*

NEW ISSUE

\$20,000,000

Aerojet-General Corporation

Promissory Notes due May 1, 1983

We have assisted in placing the Notes privately
with institutional investors.

Kidder, Peabody & Co.
Incorporated

R. W. Pressprich & Co.

May 28, 1963.

CIRCLE 79 ON READER SERVICE CARD 79

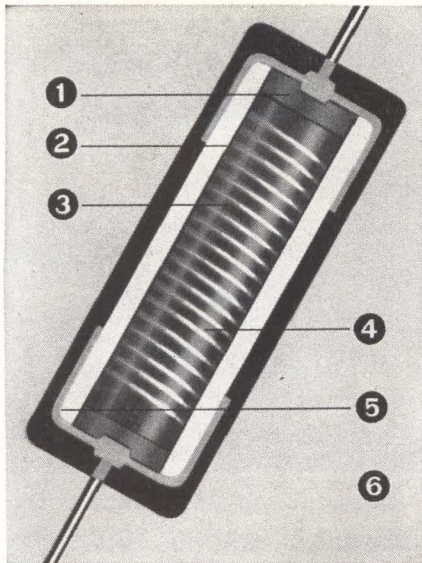

6 reasons why: **WESTON**[®] **VAMISTORS** PRECISION METAL FILM RESISTORS

have lowest noise... highest reliability

Weston Vamistors, the *most reliable* precision metal film resistors available, have the *lowest* average noise level. Using NBS resistor measurement techniques, Vamistors average below -33db (0.023 $\mu\text{V}/\text{V}$), and are guaranteed to have a level no greater than -20db (1 $\mu\text{V}/\text{V}$ in a decade of frequency).

The Vamistor's lowest noise and, therefore, outstanding reliability is a result of superior Weston design and specialized production techniques. Six major factors contribute to its remarkably low noise level:

- 1 Silver terminations are treated to prevent migration;
- 2 Tough glaze seals out moisture;
- 3 Resistance alloy is thermally bonded into glaze with patented Weston process;
- 4 Resistance spiral is precision-cut and controlled;
- 5 Capping method assures virtually perfect contact;
- 6 Incoming materials inspection, in-process control, testing and quality assurance programs guarantee specifications!

Weston Vamistors are available with the highest resistances and voltage ratings in sizes from $\frac{1}{8}$ to 2 watts. Tolerance: to 0.05%. Temperature coefficient: 0 ± 25 or $50 \text{ ppm}/^\circ\text{C}$. Stability: exceeds all MIL R-10509D specs. Write for details. We'll include Weston Spec 9800 covering High Reliability Vamistors.

WESTON 
Instruments & Electronics
Division of Daystrom, Incorporated, Newark 14, N. J.

Literature of the Week

TELEMETRY TRACKING SYSTEM Canoga Electronics Corp., 15330 Oxnard St., Van Nuys, Calif., has available a technical brochure covering the Teltrac vhf telemetry tracking system.

CIRCLE 321, READER SERVICE CARD

TUNING FORK RESONATORS Philamon Laboratories Inc., 90 Hopper St., Westbury, L. I., N. Y., offers a short form catalog on tuning fork resonators, filters and frequency generators. (322)

TUBE SOCKETS Connector Corp., 6025 No. Keystone Ave., Chicago 46, Ill. Data sheet 23A covers a complete line of versatile firm-fit Compactron tube sockets. (323)

WELDABLE STRAIN GAGES Microdot Inc., 220 Pasadena Ave., South Pasadena, Calif. An eight-page brochure describes the company's weldable strain gages. (324)

CONNECTORS Winchester Electronics, Inc., 19 Willard Rd., Norwalk, Conn. Condensed catalog No. 363 covers a line of connectors, accessories and terminals for missile, aerospace and commercial applications. (325)

COLOR TV CAMERA Tokyo Shibaura Electric Co., Ltd., Hibiya Mitsui Bldg. 12, Tokyo, Japan, has published a data sheet on the IK-32 color image orthicon camera. (326)

DRAINING RFI Corning Glass Works, Corning, N. Y., offers a brochure telling how radio frequency interference can be drained from fluorescent lighting fixtures. (327)

AUDIO SPECTRUM ANALYZER Kay Electric Co., Maple Ave., Morris County, Pine Brook, N. J., has available a catalog covering the Sona-Graph audio spectrum analyzer. (328)

REED RELAYS Douglas Randall Inc., 6 Pawcatuck Ave., Westerly, R. I. A set of five specification sheets offer a standard line of custom designed reed relays. (329)

MICROWAVE RECEIVER. Melabs, 3300 Hillview Ave., Stanford Industrial Park, Palo Alto, Calif. Brochure describes a versatile microwave laboratory receiver. (330)

NANOSECOND DATA Lumatron Electronics, 116 County Courthouse Road, New Hyde Park, N. Y., announces a data chart that lists 12 tables of parameters useful in the design and application of nanosecond circuits. (331)

POWER SUPPLY Electronic Engineering Co. of California, 1601 E. Chestnut Ave., Santa Ana, Calif. Catalog sheet describes model 745 power supply for a-c line/battery operation. (332)

TUBE BENDER Datex Corp., 1307 S. Myrtle Ave., Monrovia, Calif. A 4-



The perfect companion for professional recording

Foster's dynamic DF-1 is an omnidirectional bar-type microphone for both professional and home use. This versatile mike weighs only $\frac{1}{4}$ lb. including cord, and is just $\frac{3}{4}$ " long and $\frac{7}{8}$ " in diameter. Yet it has a range of 100 to 12,000 c.p.s. and sensitivity of -58dB ($50 \text{ K}\Omega$) $\pm 3\text{dB}$ at 1,000 c/s ($\text{OdB}=1\text{V}/\mu\text{bar}$). Your choice of 600 ohm, 10,000 ohm, or 50,000 ohm impedances.

Rugged and precision made, the DF-1 assures professional results right in your living room. Used with hi-fi, stereo, or tape recorder it faithfully recreates a broad band of audio frequencies — and takes up less space doing it. The DF-1 can be hand held, suspended from its neck cord, or clipped to your lapel. A strong diecast frame gives it complete protection for long trouble-free service.

You can get this outstanding all-new microphone now at popular prices. For further information write directly to the address below.



FOSTER ELECTRIC CO., LTD.

384 Shimo-Renjaku, Mitaka, Tokyo, Japan
CABLE: FOSTERELECTRIC MUSASHINOMITAKA

CIRCLE 208 ON READER SERVICE CARD
June 7, 1963 • electronics

page folder describes the PTB-100 tape controlled machine tool for automatically forming precise bends in thin-wall tubing. (333)

SILICON POWER TRANSISTORS Silicon Transistor Corp., Carle Place, L. I., N. Y., has published a 12-page brochure covering a wide line of silicon power transistors. (334)

R-F TEST EQUIPMENT Jerrold Electronics Corp., 15th and Lehigh Ave., Philadelphia 32, Pa., has published a short form catalog entitled "R-F Test Equipment for Quantitative Measurements." (335)

FAN Howard Industries, Inc., 1760 State St., Racine, Wis., announces a new catalog on the Cyclohm fan model 8010 with a 105 cfm air output figure. (336)

ACCELEROMETERS Columbia Research Laboratories, McDade Blvd. and Bullens Lane, Woodlyn, Pa. Data sheet describes miniature triaxial accelerometers for in-flight and laboratory test applications. (337)

LITERATURE INDEX P. R. Mallory & Co. Inc., Indianapolis, Ind., offers a 12-page booklet that contains descriptions of more than 100 Mallory catalogs and bulletins on components, dry battery systems, special metals and materials. (338)

ADJUSTABLE ROTARY POTS Weston-Instruments & Electronics Division, 614 Frelinghuysen Ave., Newark 14, N. J., offers a technical data sheet on Daystrom 319 series gangable potentiometers. (339)

PREAMPLIFIER SYSTEM Applied Technology, Inc., 930 Industrial Ave., Palo Alto, Calif. Specification sheet covers a preamplifier system for use from 0.55 to 10.75 Gc. (340)

DIGITAL SIGNAL SIMULATOR Telemetry, Inc., 12927 So. Budlong Ave., Gardena, Calif. Description and specifications of the model 510 digital signal simulator are provided in data sheet 14. (341)

RECORDER/REPRODUCER Winston Research Corp., 6711 S. Sepulveda Blvd., Los Angeles 45, Calif., has available a specification sheet on the model P-4000 which weighs less than 40 lb for a complete 14-track record/reproduce system. (342)

BATTERY PACKAGING Yardney Electric Corp., 40-52 Leonard St., New York 13, N. Y. Technical brochure describes latest developments in the design and packaging of silver-cadmium Silcad batteries. (343)

REGULATED POWER SUPPLIES Kepco Inc., 131-38 Sanford Ave., Flushing 52, N. Y. A 40-page reference handbook on applications of regulated power supplies for systems use is available. Request on company letterhead

CAMERA TUBES General Electric Co., 316 E. 9th St., Owensboro, Ky. Characteristics and operating data for five types of tv broadcast image orthicons are given in brochure ETR-3402A. (344)

TO SEE WHAT AIR CAN DO SEE GARDNER-DENVER

In the sixties alone we have added hundreds of new and improved products to our lines of compressors, rock drills, air tools, drilling rigs. So before you invest in new air equipment, find out—from Gardner-Denver—how air can serve you better.

"WIRE-WRAP" TOOLS CONNECT TERMINALS FOR KEEPS

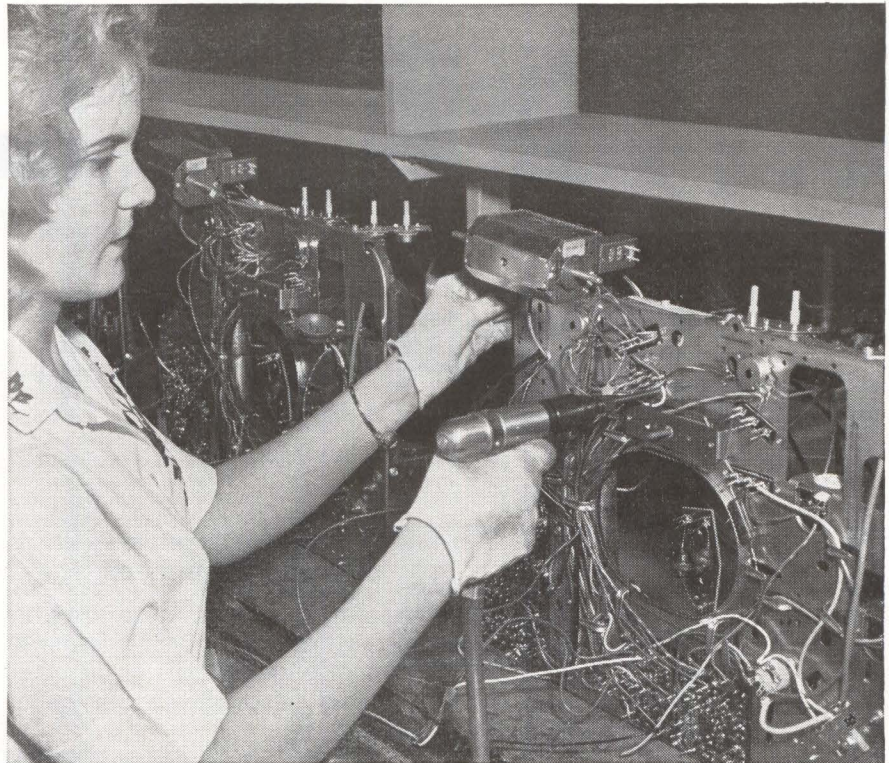

Make permanent, solderless connections that remain gas tight under severe corrosion and vibration conditions. More than 15 billion connections have been made this way—without a reported electrical failure.

Less than three seconds are required per connection.

For miniaturized components use "Wire-Wrap" tools with wire as fine as 30- or 32-gauge.

Take your choice of Gardner-Denver "Wire-Wrap" tools—air, electric or battery powered, or hand-operated models.

For complete information on "Wire-Wrap" tools—and automatic "Wire-Wrap" machines for modular panels—write for Bulletins 14-1 and 14-121.

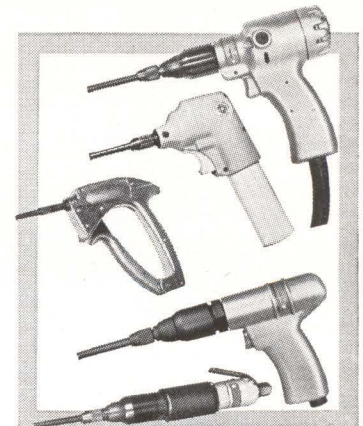

KEEP UP-TO-DATE WITH
GARDNER - DENVER

Gardner-Denver Company, Quincy, Illinois

Raytheon Promotes Three Executives



W. Rogers Hamel



Robert E. Sonnekson



John G. Stobo

RAYTHEON COMPANY, Lexington, Mass., has announced the elevation by the board of directors of three executives to the position of company vice presidents.

Elected were:

W. Rogers Hamel, general manager, Submarine Signal division, who joined Raytheon in 1951. He took his present position in July, 1959.

Robert E. Sonnekson, general manager, Commercial Apparatus and Systems division. He came to the company in 1958 from Bell Aircraft Corp., and was named to his current position in December, 1960.

John G. Stobo, assistant manager, Missile Systems division, a 21-year veteran of the company. He was named to his present post in December, 1962.

Vitro Electronics Appoints Stephens

ROBERT R. STEPHENS has been appointed manager of engineering for Vitro Electronics, a division of Vitro Corp. of America, Silver Spring, Md.

Stephens joined Vitro in 1961, and prior to taking his new post,

was chief engineer, products development, with the responsibility for initiating, expanding and converting Vitro's new and proprietary equipment to solid state circuitry and modular construction.

Royal Industries Elects McGraw

ELECTION of John T. McGraw as vice president of Royal Industries, Inc., is announced.

McGraw is executive vice president of Royal Industries' Vard division, Pasadena, Calif. He joined Vard as director of engineering in 1960, and was named executive vice president in October, 1962.

The Vard division designs and manufactures precision equipment for the nuclear and aerospace industries.

Beckman Acquires Sharp Laboratories

BECKMAN INSTRUMENTS, INC., Fullerton, Calif., has acquired Sharp Laboratories, Inc., of LaJolla, Calif., developer of advanced nuclear instrumentation.

Arnold O. Beckman, president of Beckman Instruments, said Sharp will continue to operate at its present location, functioning primarily as a developmental laboratory in the nuclear instrumentation field. The operation will continue to be headed by Rodman A. Sharp, who founded Sharp Laboratories three and a half years ago.

Metcom Elevates Wellesley Dodds

APPOINTMENT of Wellesley J. Dodds as president of Elcon Laboratories, Inc., Watertown, Mass., a wholly owned research subsidiary of Metcom, Inc., Salem, Mass., is announced.

Since December 1961, Dodds has been vice president of engineering of beam tubes at Metcom, where he

Martin-Orlando Reports Expansion



A \$2½-MILLION expansion program, including creation of a 127,800-square-foot research center, has been announced by G. T. Willey, vice president and general manager of Martin Marietta's Orlando division. Construction will be completed during this year. Facilities will be provided in the center for research in electromagnetics, electronics, physical sciences, aerospace physics, structures and mechanics and materials

LEASE A BRAND NEW PLANT

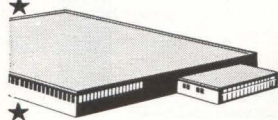

65¢ Sq. Ft.

*built for you in the finest
industrial location in the East*
THE PHILADELPHIA INDUSTRIAL PARK

651 Acres surrounding the North Philadelphia
Airport. Suburban environment with all
metropolitan utilities, services, conveniences.

Developer: **TISHMAN INDUSTRIAL PARKS, INC.**

Exclusive Agent:

BINSWANGER

CORPORATION • INDUSTRIAL LOCATION SPECIALISTS

1420 Walnut St., Phila. 2, Pa. • PE99nypacker 5-0202

CIRCLE 209 ON READER SERVICE CARD

Planning to change your address?

Use the form below to indicate a change of address. Because our issues are addressed in advance, please try to allow at least 5 weeks for change of address to become effective. Attach the address label from your most recent issue in the space provided below.

(Please print the following information for proper service)

Title or position.....

Name

Chief Job Responsibility.....

Distributor
Manufacturer

Company and Div.....

Product or Service Approx. No. of Employees

Address

City Zone State or Prov.

Mail to home address below:

Address

City Zone State or Prov.

Mail to: Fulfillment Manager, **electronics**
330 West 42nd Street, New York City 36, N. Y.

***Paste present mailing label or address
from wrapper or envelope here.**

in 1963 | 30% increase in number of visitors
 | 20% increase in number of exhibitors
for 1964 | projections indicate still greater
 | increases . . .

Exhibit at the INTERNATIONAL EXHIBITION OF ELECTRONIC COMPONENTS

FEBRUARY
7 TO 12, 1964
IN PARIS,
PORTE DE
VERSAILLES



**The largest display
in the world
covering the field
of electronics**

**All components, valves
and semiconductors,
measuring, testing
and electro-acoustic
equipments**

Send now for full information
and literature from:

**F.N.I.E.
FEDERATION NATIONALE
DES INDUSTRIES
ELECTRONIQUES**

23, RUE LUBECK—PARIS 16°
TEL. PASSY 01-16

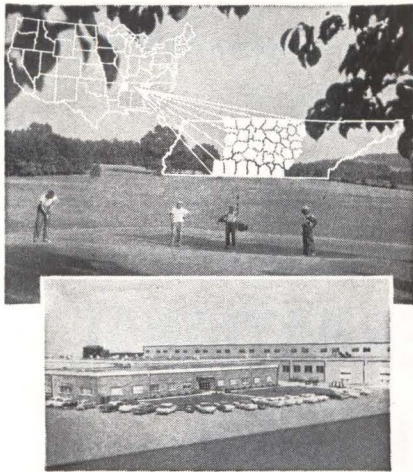

MIDDLE TENNESSEE

The Plus Location for Your Electronics Plant!

Consider the advantages of a Middle Tennessee location. You'll be in the center of an area with 23 atomic, electronic, and other research centers, including AEDC and the new state-sponsored Space Institute at Tullahoma, and NASA at Huntsville. You can draw on the facilities and faculties of 43 colleges and universities, 19 of which are in Middle Tennessee itself. In addition, Middle Tennessee also offers:

- An abundant supply of stable, easily trained, highly productive labor.
- Electric power as low as 4.25 mills per kwh, and low-cost natural gas, fuel oil and coal.
- Choice of 3 State-approved plans for local financing.
- Excellent 4-way transportation; air, rail, highway and water.
- Construction costs as low as \$5.50 per square foot, including air conditioning.
- A location central to America's major markets.
- Excellent climate with unusually fine educational, recreational and cultural advantages.



FREE BOOKLET — For your free copy of "Industrial Aptitude of Middle Tennessee", containing factual information on Location, Climate, Education, Recreation, Government, Taxes, Labor, Transportation, Utilities and Fuel, Financing Programs and Construction Costs, write or call:

M. C. Gravely, Jr., Executive Director
(telephone 256-8164, area code 615)

MIDDLE TENNESSEE INDUSTRIAL DEVELOPMENT ASSOCIATION

500 UNION ST. — DEPARTMENT 104
NASHVILLE 3, TENNESSEE

was responsible for gas plasma amplifiers and traveling wave devices.



Canoga Electronics Elects Dickinson

CANOGA ELECTRONICS CORP., Van Nuys, Calif., has elected Holley B. Dickinson president and member of the board of directors.

During his 25 years of general management and engineering experience, Dickinson has held the positions of president of Anadex Instruments, Inc.; vice president and one of the founders of American Systems, Inc.; and director of Data Lab division of Consolidated Electrodynamics Corp.

Canoga Electronics produces systems for telemetry tracking, radar, digital data handling, antennas, and pedestals.



Kollsman Promotes Frank Dupre

FRANK C. DUPRE has moved up from general manager to the newly created position of president of Kollsman Motor Corp., Dublin, Pa., a subsidiary of Standard Kollsman Industries. He was also named president of the company's Canadian subsidiary, Kollsman Motor (Canada) Ltd., Toronto. Kollsman

NEW MINIATURE DELAY LINES

1/4 CU. INCH PER μ SEC.

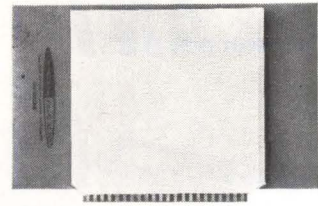

Total delay of 24.65 μ sec. in a 4 1/8" x 4" package



- Total weight: 8 1/2 oz.
- Total delay accuracy better than 1/2 of 1%
- Total delay to rise time ratio better than 40:1
- Distortion under 4%
- Temp. coefficient: 50 ppm \pm 20 ppm/ $^{\circ}$ C

WRITE FOR DETAILS
Opening exists for a Delay Line Design Engineer

ADMIRAL PALO ALTO

Palo Alto Division of Admiral Corporation
Stanford Industrial Park, Palo Alto, California

CIRCLE 210 ON READER SERVICE CARD

A NEW Catalog

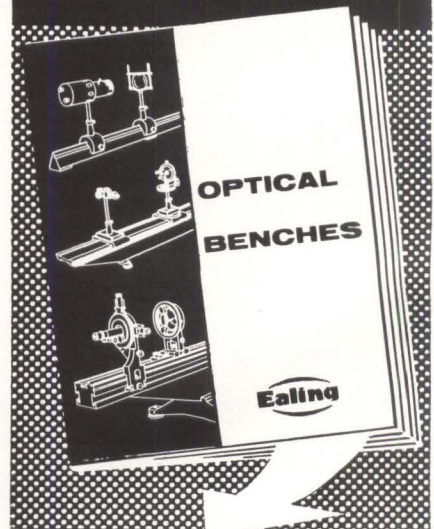

THE Ealing CORPORATION

2245 Massachusetts Ave.,
Cambridge 38, Massachusetts
Telephone: 617-491-1515

Motor produces high quality synchronous motors, servo motors and components, amplifiers and aircraft instruments.



Polarad Appoints Schindler

JOE P. SCHINDLER has been named vice president of marketing of Polarad Electronic Instruments division of Polarad Electronics Corp., Long Island City, N. Y. He was formerly director of marketing of the division.

Schindler brings to the vice presidency over 13 years of product development and engineering experience in addition to an extensive background in marketing and sales.



Alpha Wire Elects Vice President

HAROLD MASON has been elected vice president, manufacturing and engineering of Alpha Wire Corporation. He has been associated with Alpha for more than six years, and was previously plant manager and chief engineer.

In his new position, Mason will have complete responsibility for all manufacturing and engineering operations in all Alpha plants. Alpha, a subsidiary of Loral Electronics,

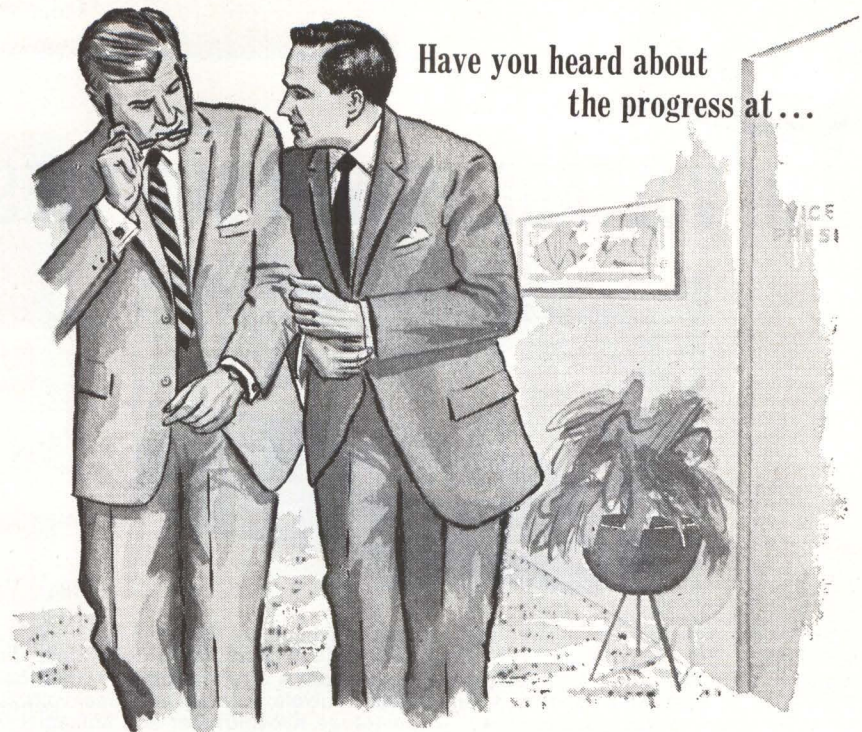

Have you heard about the progress at...

Florida's newest metropolitan industrial areas

General Electric chose Daytona Beach as the Headquarters of their Command Systems Division. The same advantages that impressed them are also available to you. LOW-COST INDUSTRIAL SITES; FAVORABLE TAXES; AMPLE POWER, WATER, AND FUEL; MINIMUM ABSENTEE-ISM, THANKS TO A MILD YEAR-ROUND CLIMATE AND CLEAN OCEAN AIR WITH A POLLEN COUNT OF LESS THAN ONE; AN INDUSTRY-MINDED COMMUNITY — ALL YOURS IN ...

DAYTONA BEACH

INDUSTRIAL AREAS

THRESHOLD OF THE RACE TO SPACE

Ormond Beach • Holly Hill • Daytona Beach • South Daytona • Daytona Beach Shores • Port Orange

THE DAYTONA BEACH AREA COMMITTEE OF 100 pledges its complete cooperation in helping you find a profitable industrial site. Direct your inquiry to J. Saxton Lloyd, Chairman, who will hold all such inquiries in his personal file in the very strictest confidence.

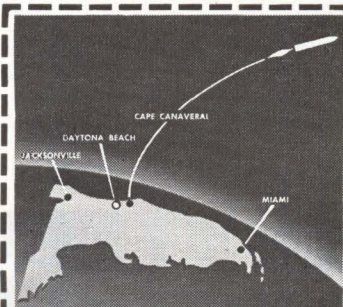

Mr. J. Saxton Lloyd, Chairman
Committee of 100
Daytona Beach Industrial Areas
Dept. B 12 — Daytona Beach, Fla.

Please send detailed information on the Daytona Beach Industrial Areas.

NAME.....TITLE.....
COMPANY.....
ADDRESS.....
CITY.....ZONE.....STATE.....

All inquiries held in strict confidence

NEW

HIGH VOLTAGE POWER SUPPLIES



PSR Series, pictured above offer these important features: Range 5 to 30 KV, 2 to 30 MA • Regulation $\pm .05\%$ • Ripple .1% RMS • Completely Solid State Circuitry • Light Weight • Rack Height $8\frac{3}{4}$ " maximum • Dry Insulation • Overload Protection • Reversible Polarity • Simplified Controls; coarse and fine voltage, ON-OFF meter reversing switch • Triple-Range Kilovoltmeter and Milliammeter. Write for New 1963 High Voltage Bulletin.

ELECTRONICS DIVISION
RESEARCH-COTTRELL, INC., BOUND BROOK, NEW JERSEY

CIRCLE 212 ON READER SERVICE CARD

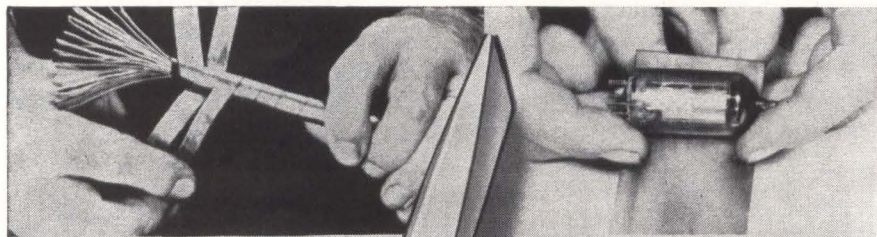

CUT IT, WRAP IT!

NETIC AND CO-NETIC
MAGNETIC SHIELDS
APPLIED
IN SECONDS

Guard against performance degradation from unpredictable magnetic field conditions to which your equipment may be exposed. Economical CO-NETIC and NETIC Magnetic Shielding Foils are adaptable to any size or shape components. Simply cut with ordinary scissors.

Available in continuous lengths on rolls up to 15" wide. Furnished in final annealed state.

Co-Netic and Netic alloys are not affected significantly by vibration or shock, assuring components performance repeatability over a wider range of flux intensities.

They are also non-retentive and do not require periodic annealing. When grounded, they shield electrostatic as well as magnetic fields. They have many applications in satellite instrumentation and many other magnetically sensitive devices.

MAGNETIC SHIELD DIVISION

Perfection Mica Co. Phone EVERglade 4-2122
1322 North Elston Avenue, Chicago 22, Illinois

has plants in New York City, Los Angeles, and Holbrook, Long Island.

Simpson Instruments Appoints Billman

CHARLES R. BILLMAN has been named executive vice president of Simpson Instruments, Inc., South Pasadena, Calif. He was formerly vice president of manufacturing for the Simpson Electric Co. of Chicago.

PEOPLE IN BRIEF

Gene Hegedus, formerly with Ryan Aeronautical Co., appointed engineering mgr. at Mechatronics div., Servomechanisms/Inc. **R. L. Pritchard**, previously with Texas Instruments, named director of engineering at Motorola's Semiconductor Products div. **U. Victor Turner** promoted to engineering mgr. for the Sperry Electro Devices Laboratory. **David L. Hill**, founder of Physical Science Corp., heads up its outgrowth, Nanosecond Systems, Inc. Associated with him as v-p for engineering is **Albert L. Whetstone**, recently with the U. of Pennsylvania Physics dept. **E. Grogan Shelor Jr.** moves up to director of engineering at Bendix Radio div. **Thomas Lyons** advances to mgr., quality assurance, at Potter Instrument Co., Inc. **Robert J. Weismann**, from mgr. of mfg. to mgr. of engineering for Ampex Corp. video and instrumentation div. Three promotions at United Aircraft Corporation's Norden div.; **Robert D. Rinehart** to component engineering mgr.; **Leo Botwin**, radar systems engineering mgr.; and **Frank S. Preston**, advance engineering mgr. Corning Glass Works ups **Richard A. O'Brien** to product mgr.-fluid amplifiers in its Electronic Products div. **Ronald T. Fogg**, ex-Canadian Aviation Electronics, Ltd., appointed v-p, manufacturing, of the Servotron Corp. **Hugh Brady** leaves Space Technology Labs to become director of the Apollo Program at the Milwaukee plants of AC Spark Plug div. of General Motors. **Donald Rappaport** elevated to v-p, g-m of the Pacific div. of Alpha Wire Corp.

electronics

WEEKLY QUALIFICATION FORM FOR POSITIONS AVAILABLE

ATTENTION: ENGINEERS, SCIENTISTS, PHYSICISTS

This Qualification Form is designed to help you advance in the electronics industry. It is unique and compact. Designed with the assistance of professional personnel management, it isolates specific experience in electronics and deals only in essential background information.

The advertisers listed here are seeking professional experience. Fill in the Qualification Form below.

STRICTLY CONFIDENTIAL

Your Qualification form will be handled as "Strictly Confidential" by ELECTRONICS. Our processing system is such that your form will be forwarded within 24 hours to the proper executives in the companies you select. You will be contacted at your home by the interested companies.

WHAT TO DO

1. Review the positions in the advertisements.
2. Select those for which you qualify.
3. Notice the key numbers.
4. Circle the corresponding key number below the Qualification Form.
5. Fill out the form completely. *Please print clearly.*
6. Mail to: Classified Advertising Div., ELECTRONICS, Box 12, New York 36, N. Y. (No charge, of course).

COMPANY	SEE PAGE	KEY #
ATOMIC ENERGY OF CANADA LIMITED Chalk River, Ontario, Canada	88	1
ATOMIC PERSONNEL INC. Philadelphia, Penna.	53*	2
GENERAL DYNAMICS/ASTRONAUTICS San Diego, California	33, 34	3
INTERNATIONAL BUSINESS MACHINES CORP. New York, New York	89	4
JERROLD ELECTRONICS CORPORATION Philadelphia, Penna.	88	5
LOCKHEED MISSILES & SPACE CO. Div. of Lockheed Aircraft Corp. Sunnyvale, California	49*	6
PAN AMERICAN WORLD AIRWAYS INC. Guided Missiles Range Div. Patrick AFB, Fla.	55*	7
UNION CARBIDE NUCLEAR COMPANY A Div. of Union Carbide Corporation Oak Ridge, Tennessee	88	8
U.S.A.F. AIR FORCE LOGISTICS COMMAND Joint Professional Placement Office New York, N. Y.	14	9

* These advertisements appeared in the May 31st issue.

(cut here)

electronics WEEKLY QUALIFICATION FORM FOR POSITIONS AVAILABLE

(cut here)

(Please type or print clearly. Necessary for reproduction.)

Personal Background

NAME

HOME ADDRESS

CITY ZONE STATE

HOME TELEPHONE

Education

PROFESSIONAL DEGREE(S)

MAJOR(S)

UNIVERSITY

DATE(S)

FIELDS OF EXPERIENCE (Please Check)

6763

- | | | |
|--|--|---------------------------------------|
| <input type="checkbox"/> Aerospace | <input type="checkbox"/> Fire Control | <input type="checkbox"/> Radar |
| <input type="checkbox"/> Antennas | <input type="checkbox"/> Human Factors | <input type="checkbox"/> Radio—TV |
| <input type="checkbox"/> ASW | <input type="checkbox"/> Infrared | <input type="checkbox"/> Simulators |
| <input type="checkbox"/> Circuits | <input type="checkbox"/> Instrumentation | <input type="checkbox"/> Solid State |
| <input type="checkbox"/> Communications | <input type="checkbox"/> Medicine | <input type="checkbox"/> Telemetry |
| <input type="checkbox"/> Components | <input type="checkbox"/> Microwave | <input type="checkbox"/> Transformers |
| <input type="checkbox"/> Computers | <input type="checkbox"/> Navigation | <input type="checkbox"/> Other |
| <input type="checkbox"/> ECM | <input type="checkbox"/> Operations Research | <input type="checkbox"/> |
| <input type="checkbox"/> Electron Tubes | <input type="checkbox"/> Optics | <input type="checkbox"/> |
| <input type="checkbox"/> Engineering Writing | <input type="checkbox"/> Packaging | <input type="checkbox"/> |

CATEGORY OF SPECIALIZATION

Please indicate number of months experience on proper lines.

	Technical Experience (Months)	Supervisory Experience (Months)
RESEARCH (pure, fundamental, basic)
RESEARCH (Applied)
SYSTEMS (New Concepts)
DEVELOPMENT (Model)
DESIGN (Product)
MANUFACTURING (Product)
FIELD (Service)
SALES (Proposals & Products)

CIRCLE KEY NUMBERS OF ABOVE COMPANIES' POSITIONS THAT INTEREST YOU

1 2 3 4 5 6 7 8 9 10 11 12 13 14 15 16 17 18 19 20 21 22 23 24 25



EMPLOYMENT OPPORTUNITIES

The Advertisements in this section include all employment opportunities—executive, management, technical, selling, office, skilled, manual, etc. Look in the forward section of the magazine for additional Employment Opportunities advertising.

Positions Vacant
Positions Wanted
Part Time Work

Civil Service Opportunities
Selling Opportunities Wanted
Selling Opportunities Offered

Employment Agencies
Employment Services
Labor Bureaus

DISPLAYED

The advertising rate is \$40.17 per inch for all advertising appearing in other than a contract basis. Contract rates quoted on request.

An advertising inch is measured 7/8" vertically on a column—3 columns—30 inches to a page.

Subject to Agency Commission.

Send NEW ADS to CLASSIFIED ADV. DIV. of ELECTRONICS, P.O. Box 12, N. Y. 36, N. Y.

RATES

\$2.70 per line, minimum 3 lines. To figure advance payment count 5 average words as a line.

Box Numbers—counts as 1 line.

Discount of 10% if full payment is made in advance for 4 consecutive insertions.

Not subject to Agency Commission.

UNDISPLAYED



PHYSICISTS AND ELECTRICAL ENGINEERS

for the
PHYSICS DIVISION
CHALK RIVER NUCLEAR LABORATORIES

The Electronics Branch of this Division has a number of openings for Graduates with M.Sc. or Ph.D. degrees in physics and electrical engineering who are interested in the application of digital techniques to data handling systems for nuclear physics research and to reactor control and safety problems. These positions offer excellent opportunities to do original circuit design and to participate in active physics research and reactor development programs.

Qualified physicists or engineers should send a resume of their qualifications and experience to:

FILE 5 A
ATOMIC ENERGY OF CANADA LIMITED
Chalk River, Ontario

INSTRUMENT TECHNICIANS THE OAK RIDGE NATIONAL LABORATORY Operated by UNION CARBIDE NUCLEAR COMPANY

at
Oak Ridge, Tennessee
HAS OPENINGS FOR

highly skilled instrument technicians to work with engineers in the installation and maintenance of process control and electronic instrumentation for nuclear reactors and associated experiments. Nuclear reactor control system experience desirable but not essential.

Minimum high school education, with additional training in either the physical sciences, instrumentation, or electronics, and at least 3 years experience in installation and maintenance of complex instrumentation and control systems. Entrance rate \$3.19 per hour; \$3.25 per hour after six months. Reasonable interview and relocation expenses paid by the Company.

Excellent Working Conditions
and
Employee Benefit Plans
An Equal Opportunity Employer

Send detailed resume to:
Central Employment Office

UNION CARBIDE NUCLEAR COMPANY
A Division of Union Carbide Corporation
Post Office Box M Oak Ridge, Tennessee

SENIOR DESIGN ENGINEER INDUSTRIAL TEST EQUIPMENT

Well established steadily expanding company has an immediate opening for a Senior Engr. with BSEE or equivalent who has acquired at least 5 yrs. of valuable experience in the design of test equipment with particular emphasis on high frequency. Salary commensurate with experience. Send resume and salary requirements to:

Director of Industrial Relations
Jerrod Electronics Corporation, 15th & Lehigh Sts.
Philadelphia, Pennsylvania

SEARCHLIGHT SECTION

(Classified Advertising)

BUSINESS OPPORTUNITIES
EQUIPMENT - USED or RESALE

DISPLAYED RATE

The advertising rate is \$27.25 per inch for all advertising appearing on other than a contract basis. Contract rates quoted on request. AN ADVERTISING INCH is measured 7/8 inch vertically on one column, 3 columns—30 inches—to a page. EQUIPMENT WANTED or FOR SALE ADVERTISEMENTS acceptable only in Displayed Style.

UNDISPLAYED RATE

\$2.70 a line, minimum 3 lines. To figure advance payment count 5 average words as a line. PROPOSALS, \$2.70 a line an insertion. BOX NUMBERS count as one line additional in undisplayed ads. DISCOUNT OF 10% if full payment is made in advance for four consecutive insertions of undisplayed ads (not including proposals).

RADIO RESEARCH INSTRUMENT CO.

AUTO-TRACK & TELEMETRY ANTENNA PEDESTALS
3 & 10 CM. SCR. 984 AUTOTRACK RADARS.
AN/TPS-10 SEARCH, AN/TPS-10 HT. FINDERS.
AN/FRN-228CA, AN/APS-10 NAVIG. & WEATHER.
AN/APS-15B PRECISION, AN/APQ-35B PRECISION.
AN/APS-37A SEARCH, DOZENS MORE.
5-12 MEGAWATT HIGH POWER PULSERS.

RADIO RESEARCH INSTRUMENT CO.
550 Fifth Ave., New York Judson 6-4691

RADAR SYSTEMS & COMPONENTS/ IMMEDIATE DELIVERY

CIRCLE 950 ON READER SERVICE CARD

LOOKING FOR USED/SURPLUS ELECTRONIC EQUIPMENT/COMPONENTS?

For an up-to-date listing of such equipment see Searchlight Section of May 10th.

Are you a COMPLETELY INFORMED electronics engineer?

Today you may be working in microwaves. But on what project will you be working tomorrow? You *could* have read **electronics** this past year and kept abreast of, say, microwave technology. *There were 96 individual microwave articles between July, 1961 and June, 1962!*

But suppose tomorrow you work in some area of standard electronic components, in semiconductors, in systems? Would you be up-to-date in these technologies? Did you read the more than 3,000 editorial pages that **electronics'** 28-man editorial staff prepared last year?

electronics is edited to keep you current *wherever* you work in the industry, *whatever* your job function(s). If you do not have your own copy of **electronics**, subscribe today via the Reader Service Card in this issue. Only 7½ cents a copy at the 3 year rate.

electronics

IBM asks basic questions in materials

How can we develop better semiconductors?

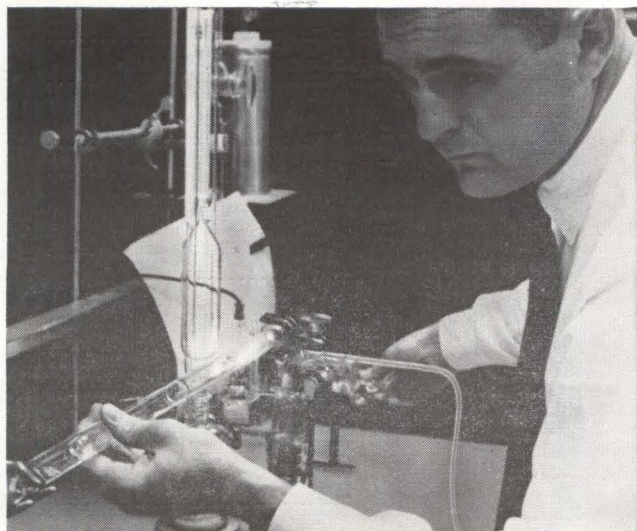

In this method of preparing ultrapure gallium arsenide, gallium reacts with arsenic in a quartz tube with oxygen added under pressure to suppress dissociation of SiO_2 .

The immense speeds at which computers must operate place stringent requirements on the transistors and diodes which perform calculations. To increase further the speed of semiconductor devices now operating in millionths or even billionths of a second requires not only refinements in present designs and fabrication techniques, but also new materials that are inherently superior to materials presently being used, like germanium and silicon. IBM has been working to transform the great potential of one such new material, gallium arsenide, into useful devices. Gallium arsenide has a much higher electron mobility than germanium and silicon. Thus it is potentially much faster. It has a larger band gap, permitting operation at higher temperatures. It is chemically and mechanically stable. However, the difficulty of producing gallium arsenide of sufficient purity has, until recently, limited its application.

IBM scientists have developed the reproducible processes, shown above, which greatly improve the purity of the material. Using their new processes, they can produce materials with electron mobilities—an important measure of purity—of about 8,000 $\text{cm}^2/\text{volt}\cdot\text{sec.}$, as compared with previously reported mobilities of about 6,000 $\text{cm}^2/\text{volt}\cdot\text{sec.}$ Mobilities in this high-purity gallium arsenide are about twice those of germanium and four times those of silicon. These mobilities may make it feasible to fabricate semiconductor devices of higher speed than previously available.

The potential of high-purity gallium arsenide was

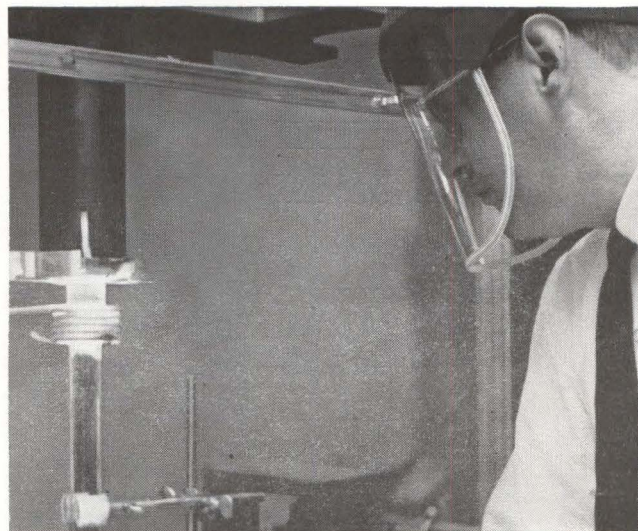

In this alternative method, gallium arsenide crystals are pulled from gallium and arsenic melted in aluminum nitride crucibles, which do not liberate silicon contaminants.

first exploited by IBM scientists in a new gallium arsenide-germanium heterojunction diode. The difference in conduction band energies between gallium arsenide and germanium permits a diode to be made using n-type material on both sides of the junction. In other words, n-type gallium arsenide is used on one side of the junction and n-type germanium on the other. Such a configuration virtually eliminates minority carriers. Since the chief barrier to faster diode switching has been minority-carrier storage time, the heterojunction device has the potential for much faster switching than conventional p-n junction diodes. Its calculated switching time is on the order of a few picoseconds (trillionths of a second). Measurements have shown it to be faster than the fastest available measuring circuits. This configuration had been tried earlier, but was unsuccessful until better gallium arsenide was made by IBM scientists. This is an example of the way in which the development of new materials like gallium arsenide makes it possible to produce components which can keep up with the increasing speeds of new generations of computers.

If you have been searching for an opportunity to make important contributions in materials, space, programming systems, or any of the other fields in which IBM scientists and engineers are finding answers to basic questions, please contact us. IBM is an Equal Opportunity Employer. Write to: Manager of Professional Employment, IBM Corp., Dept. 554F1, 590 Madison Avenue, New York 22, N. Y.

INDEX TO ADVERTISERS

Admiral Corp. Palo Alto Div.....	84	• Hewlett-Packard Company	6, 10 11, 61	Struthers-Dunn Inc.	63
• Acromag, Inc.	71	Hughes Aircraft Co.....	18, 19	Super Tool Co.....	25
Allen-Bradley Co.	13	• IT&T, Electron Tube Div.....	57	• Syntronic Instruments, Inc.....	78
• Ballantine Laboratories, Inc.....	73	International Resistance Co.....	65	• Tempo Instrument, Inc.....	38
Bausch & Lomb, Inc.....	69	• Japan Piezo Electric Co., Ltd.....	76	Texas Instruments Incorporated Industrial Products Group.....	27
Beattie-Coleman Inc.	58	Jerrold Electronics	4	United States Air Force.....	14
Bean & Co., Morris.....	22	Kidder Peabody & Co., Inc.....	79	United States Energy Corp.....	58
Bell Telephone Laboratories.....	15	Krohn-Hite Corp.	32	Weston Instruments A Division of Daystrom Inc.....	80
Binswanger Corp.	83	• Lambda Electronics Corp.....	5	White, S. S.....	74
• Borg Equipment Division Amphenol-Borg Electronics Corp.	37	Machlett Laboratories, Inc.....	21		
• Brush Instruments Div. of Clevite Corp.....	3rd cover	• Magnetic Shield Division of Perfection Mica Co...	86		
Chicago Dynamic Industries Inc....	79	Mallory and Co., Inc., P. R.....	30, 31 66, 67		
Cominco Products, Inc.....	78	Metcom Inc.	68		
• Coto-Coil Co., Inc.....	79	Middle Tennessee Industrial Development Association	84		
CTS of Berne, Inc.....	75	• North Atlantic Industries, Inc.....	59		
Daytona Beach	85	OKI Electric Industry Co., Ltd.....	71		
Ealing Corp., The.....	84	• Panduit Corp.	79		
Electronic Modules Corp.....	62	• Perfection Mica Co. Magnetic Shield Div.....	86		
Electronic Research Associates, Inc.	77	• Potter Instrument Co., Inc.....	17		
F. N. I. E.....	83	Precision Instrument Co.....	55		
Ford Instrument Co. Div. of Sperry Rand Corp.....	80	• Radio Corporation of America	4th cover		
• Foster Electric Co., Ltd.....	80	Research-Cottrell, Inc.	86		
Gardner-Denver Company	81	Seco Electronics, Inc.....	72		
General Dynamics/ Astronautics	33, 34	Spectra-Physics Inc.	28		
• General Electric Co. Rectifier Components Dept.....	29	Sprague Electric Co.....	9		
General Radio Co.....	2nd cover				
Gudebrod Bros. Silk Co., Inc.....	36				

CLASSIFIED ADVERTISING

F. J. Eberle, Business Mgr.

EMPLOYMENT OPPORTUNITIES 88, 89

EQUIPMENT

(Used or Surplus New)

For Sale 88

ADVERTISERS INDEX

Atomic Energy of Canada Limited	88
International Business Machines...	89
Jerrold Electronics Corporation...	88
• Radio Research Instrument Co.....	88
Union Carbide Nuclear Company a Division of Union Carbide Corporation	88

• See advertisement in the July 25, 1962 issue of *Electronics Buyers' Guide* for complete line of products or services.

This index and our Reader Service Numbers are published as a service. Every precaution is taken to make them accurate, but **electronics** assumes no responsibilities for errors or omissions.

electronics



Audit Bureau
of Circulation



Associated Business
Publications

Audited Paid Circulation

JAMES T. HAUPTLI

Advertising Sales Manager

DAVID CUNNIFF

Promotion Manager

Electronics Buyers' Guide

R. S. QUINT
General Manager

RICHARD J. TOMLINSON
Business Manager

THEODORE R. GEIPEL
Production Manager

ADVERTISING REPRESENTATIVES

ATLANTA (9):

Michael H. Miller, Robert C. Johnson
1375 Peachtree St. N.E., Trinity 5-0523
(area code 404)

BOSTON (16):

William S. Hodgkinson, Donald R. Furth
McGraw-Hill Building, Copley Square,
Congress 2-1160 (area code 617)

CHICAGO (11):

Harvey W. Wernecke, Robert M. Denmead
645 North Michigan Avenue, Mohawk 4-5800
(area code 312)

CLEVELAND (13):

Paul T. Fegley
55 Public Square, Superior 1-7000
(area code 216)

DALLAS (1):

Frank Le Beau
The Vaughn Bldg., 1712 Commerce St.
Riverside 7-9721 (area code 214)

DENVER (2):

John W. Patten
Tower Bldg., 1700 Broadway,
Alpine 5-2981 (area code 303)

HOUSTON (25):

Kenneth George
Prudential Bldg., Halcombe Blvd.,
Riverside 8-1280 (area code 713)

LOS ANGELES (17):

Ashley P. Hartman, John G. Zisch,
William C. Gries
1125 W. 6th St., Huntley 2-5450
(area code 213)

NEW YORK (36):

Donald H. Miller, Henry M. Shaw,
George F. Werner
500 Fifth Avenue, LO-4-3000
(area code 212)

PHILADELPHIA (3):

Warren H. Gardner, William J. Boyle
6 Penn Center Plaza, LOcust 8-4330
(area code 215)

SAN FRANCISCO (11):

Richard C. Alcorn
255 California Street, Douglas 2-4600
(area code 415)

LONDON W1:

Edwin S. Murphy Jr.
34 Dover St.

FRANKFURT/Main:

Mathée Herfurth
85 Westendstrasse

GENEVA:

Michael R. Zeynel
2 Place du Port

TOKYO:

George Olcott,
1, Kotohiracho, Shiba, Minato-ku

Actual width of record is 6 inches

At Brush it's a matter of record

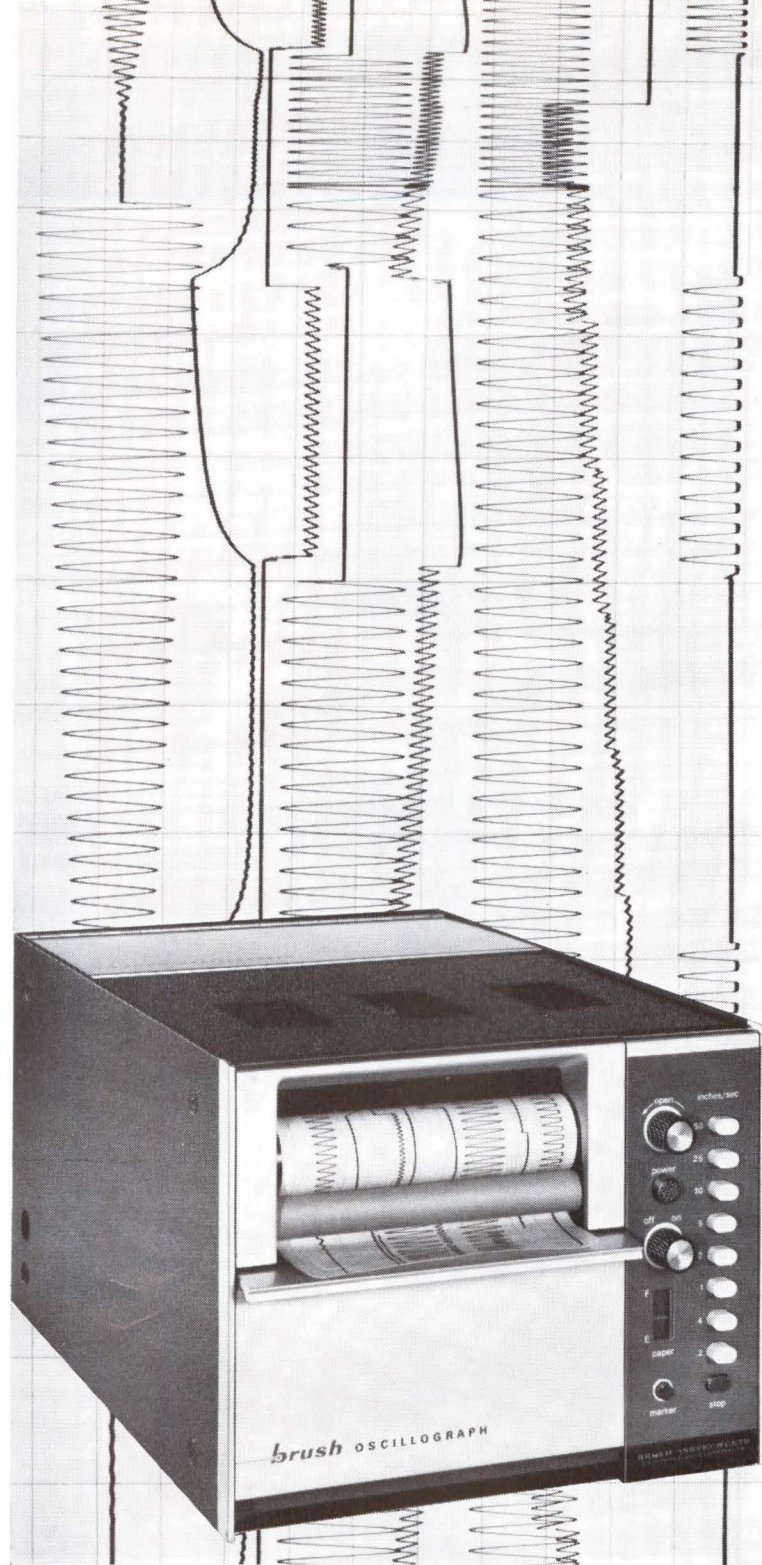

. . . and *this* record speaks for itself. It was made by the new oscillograph Series 2300 . . . a product of Brush's advanced recording system design. Its unique optical system produces these high contrast traces . . . at all writing speeds. An extremely stable tungsten light source eliminates cluttered records caused by ultra-violet "jitter" or RF interference. The start-up of this low-cost lamp is virtually instantaneous. Overall system linearity is better than 2%. Eight record speeds are controlled by pushbuttons. Paper take-up is built-in. A complete line of accessories accommodates special requirements. So now, you can record over the whole range of most-used frequencies with Brush systems incorporating all the known refinements in oscillography. Write for full details.

brush INSTRUMENTS
DIVISION OF CLEVITE 37TH AND PERKINS, CLEVELAND 14, OHIO

CIRCLE 901 ON READER SERVICE CARD

Now from RCA...

THE RECTIFIERS THAT STARTED A NEW ERA IN SPACE SAVINGS AND RELIABILITY!!!

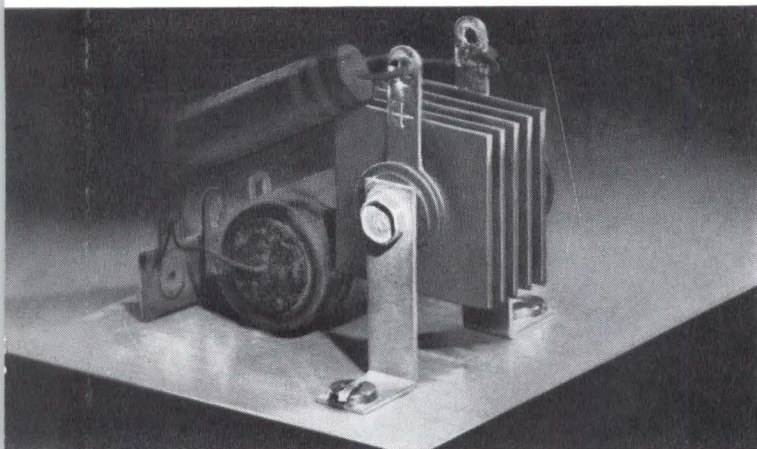

Space-consuming plate-type rectifiers take valuable chassis area, require additional space for adequate isolation and mounting hardware.

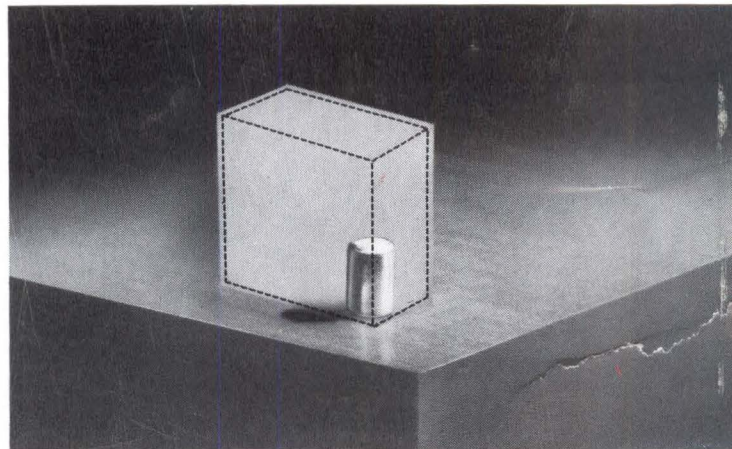

New, space-saving, single-ended tubular RCA silicon diffused-junction rectifiers cut chassis size and weight...ADD the proved reliability of silicon...at no extra cost.

NEW RCA 125-MA SILICON RECTIFIERS OFFER SPACE SAVINGS UP TO 90% AT NO EXTRA COST

Here's silicon rectifier reliability—in a hermetically sealed package—at prices you'd expect to pay for selenium types. RCA 1N3754, 1N3755, and 1N3756 now provide the dependability of the silicon diffused junction in 125-milliampere rectifiers for the 100- to 400-PRV range.

By combining the small size of the standard hermetically sealed TO-1 transistor case and the small size of the silicon junction, RCA engineers have reduced rectifier space requirements up to 90% compared with conventional plate-type rectifiers. These tiny 125-ma units measure $\frac{3}{8}$ " x $\frac{1}{4}$ " diameter compared with conventional 100-ma selenium units which occupy approximately a cubic inch.

If your product can use the long-life advantages of silicon rectifiers... if you can make use of substantial space savings... call your RCA Representative now or write RCA Semiconductor and Materials Division, Commercial Engineering, Sec. EN6-1, Somerville, N.J.



NEW 1000-VOLT INSULATED AXIAL-LEAD RECTIFIER 1N3563 Now Available in Quantity

For high-voltage applications, RCA has now added a new member to its family of axial-lead tubular silicon diffused-junction rectifiers. This new 400-ma rectifier is hermetically sealed in the standard TO-1 size transistor case and insulated with an extremely-high-dielectric plastic.

Ask your RCA Representative about the new 1,000-Volt Rectifier and the eight other types in RCA's family of axial-lead tubular silicon rectifiers with PRV's from 200 to 800 volts.

Available through your RCA Distributor

RCA SEMICONDUCTOR AND MATERIALS DIVISION FIELD OFFICES—East: 744 Broad St., Newark 2, N. J., HU 5-3900 • 605 Marlon Pike, Erlton, N. J., HA 8-4802 • 731 James St., Room 402, Syracuse 3, N. Y., GR 4-5591 • Greater Baltimore Area, 1725 "K" St., N.W., Washington 6, D.C., FE 7-8500 • **Northeast:** 64 "A" St., Needham Heights 94, Mass., HI 4-7200 • **Southeast:** 1520 Edgewater Dr., Suite No. 1, Orlando, Fla., GA 4-4768 • **Central:** Suite 1154 Merchandise Mart Plaza, Chicago 54, Ill., 527-2900 • 2132 East 52 St., Indianapolis 5, Ind., CL 1-1405 • 5805 Excelsior Blvd., Minneapolis 15, Minn., WE 9-0676 • 714 New Center Bldg., Detroit 2, Mich., TR 5-5600 • 7905 Carpenter Freeway, Dallas 7, Texas, ME 1-9720 • Continental Terrace Bldg., 2785 North Speer Blvd., Room 301, Denver 11, Colo., 477-1688 • **West:** 6801 E. Washington Blvd., Los Angeles 22, Calif., RA 3-8361 • 1838 El Camino Real, Burlingame, Calif., OX 7-1620 • 2250 First Ave. So., Seattle 4, Wash., MA 2-8816 • **Government:** 224 N. Wilkinson St., Dayton 2, Ohio, BA 6-2366 • 1725 "K" St., N.W., Washington 6, D.C., FE 7-8500 • RCA INTERNATIONAL DIVISION, 30 Rockefeller Plaza, New York 20, N. Y., Cable Address: RADIOINTER, N. Y.

CIRCLE 902 ON READER SERVICE CARD



The Most Trusted Name in Electronics