

4-POLE VOLTAGE CONTROLLED FILTER

DESCRIPTION

The SSM2044 is a low cost 4-pole voltage controlled filter whose design has been optimized for use as an electronic music lowpass filter. On-chip voltage control of resonance allows direct and easy interfacing with programmers and controllers. A novel filtering technique* provides extended control range, low noise and high control rejection for "pop"-free performance. The filter can also be used as a low distortion sinewave oscillator. No external ladder network is required making the device a real cost and space saver in polyphonic applications.

FEATURES

- Low Cost
- High Control Rejection (40db typical for 1000 to 1 sweep)
- $\pm 18V$ to $\pm 5V$ Supplies
- Minimum External Parts Count
- Current Output
- 90db Signal-to-Noise
- 10,000 to 1 Minimum Sweep Range
- On-Chip Resonance Control
- Differential Signal Inputs
- Stable Resonance Over Frequency Sweep

*Patent applied for.

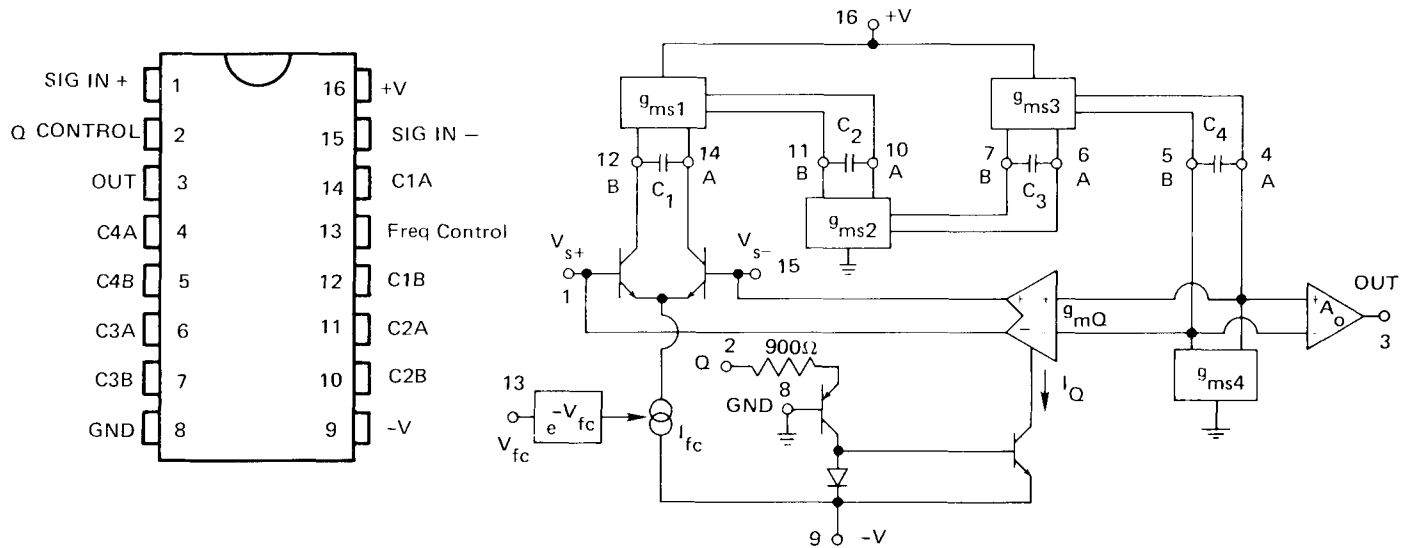

Functional Block Diagram

SPECIFICATIONS

STORAGE TEMPERATURE

OPERATING TEMPERATURE

@ $V_s = \pm 15$ and $T_A = 25^\circ\text{C}$

-55°C to $+125^\circ\text{C}$

0°C to $+70^\circ\text{C}$

PARAMETER	MIN	TYP	MAX	UNITS	CONDITIONS
Positive Supply Range	+5	+15	+18	V	$V_{FC} = \text{GND}$ $V_{FC} = \text{GND}$
Negative Supply Range	-5	-15	-18	V	
Positive Supply Current	1.0	1.4	2.0	mA	
Negative Supply Current	4.5	6.2	8.0	mA	
Frequency Control Range	10,000:1	50,000:1	—		$V_{s+} = V_{s-} = \text{GND}$ $-90\text{mV} \leq V_{FC} \leq +90\text{mV}$ $V_{s+} = V_{s-} = V_{FC} = \text{GND}$ Untrimmed
Frequency Control Feedthrough	—	-40db	-30db		
Output Offset $I_O/I_{O\text{Max}}$		0.05	0.2		
Frequency Control Offset f/fnom	0.6	1	1.5		
Q Control Input Impedance	675	900	1200	Ω	$V_{OC} \geq 0.7\text{V}$ $-90\text{mV} \leq V_{fc} \leq +90\text{mV}$ Untrimmed Trimmed
Q Current at Oscillation	400	425	450	μA	
Q Control Feedthrough	—	-30db	-20db		
Q Control Feedthrough			-60db		
Max Available Control Current	1.25	1.7	2.2	mA	
Freq. Control Input Range	-120	—	+180	mV	
Max Output Signal Current $I_{O\text{Max}}$	± 300	± 400	± 520	μA	
Signal to Noise	—	90db	—		

*FINAL SPECIFICATIONS MAY BE SUBJECT TO CHANGE.

Figure 1 below shows the amplitude vs frequency response for the 2044 at different Q or resonance settings. The solid curve is the response of the filter at minimum Q which is a gradual rolloff approaching -24db/octave at high frequencies. As Q is increased, low frequency components are suppressed and components near the cutoff frequency are emphasized. For all Q settings below oscillation the final rolloff at high frequencies is -24db/octave. At high Q settings the filter will oscillate with a pure sinewave at the cutoff frequency. This waveform can be used as a tone source if the design procedures given below are followed.

The second figure below shows Q or resonance of a four-pole lowpass filter as a function of feedback or Q control current. The function changes very slowly with control current at the low end but increases very rapidly as oscillation is approached. In general, this type of filter causes a problem when designing a Q panel control that has the right *feel*. The optimum control pot would have the reciprocal of this response; a requirement approximated by an audio pot connected in reverse of its normal configuration: a "reverse audio" pot. To obtain maximum resolution from the pot, a resistor that is one-third of its value can be connected in series to ground. This will discard the lower 25% of the Q response curve where almost nothing happens. Figure 4.

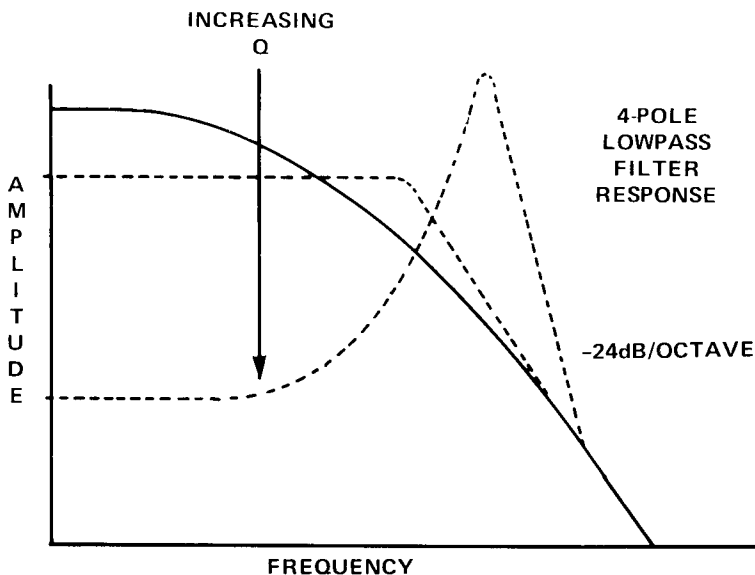

Figure 1

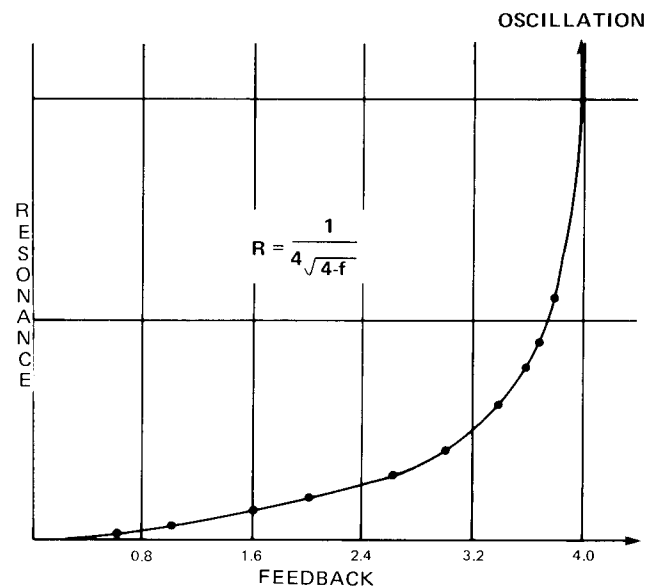

Figure 2

