

Processing DCF77-time signals
with the MB90670/5 series
using the ICU

© Fujitsu Microelectronics Europe GmbH, Microcontroller Application Group

History

18 th Feb. 97	MM	V1.0	started
28 th June 00	TKa	V1.1.	New format

Warranty and Disclaimer

To the maximum extent permitted by applicable law, Fujitsu Mikroelektronik GmbH restricts its warranties and its liability for **all products delivered free of charge** (eg. software include or header files, application examples, application Notes, target boards, evaluation boards, engineering samples of IC's etc.), its performance and any consequential damages, on the use of the Product in accordance with (i) the terms of the License Agreement and the Sale and Purchase Agreement under which agreements the Product has been delivered, (ii) the technical descriptions and (iii) all accompanying written materials. In addition, to the maximum extent permitted by applicable law, Fujitsu Mikroelektronik GmbH disclaims all warranties and liabilities for the performance of the Product and any consequential damages in cases of unauthorised decompiling and/or reverse engineering and/or disassembling. **Note, all these products are intended and must only be used in an evaluation laboratory environment.**

1. Fujitsu Mikroelektronik GmbH warrants that the Product will perform substantially in accordance with the accompanying written materials for a period of 90 days from the date of receipt by the customer. Concerning the hardware components of the Product, Fujitsu Mikroelektronik GmbH warrants that the Product will be free from defects in material and workmanship under use and service as specified in the accompanying written materials for a duration of 1 year from the date of receipt by the customer.
2. Should a Product turn out to be defect, Fujitsu Mikroelektronik GmbH's entire liability and the customer's exclusive remedy shall be, at Fujitsu Mikroelektronik GmbH's sole discretion, either return of the purchase price and the license fee, or replacement of the Product or parts thereof, if the Product is returned to Fujitsu Mikroelektronik GmbH in original packing and without further defects resulting from the customer's use or the transport. However, this warranty is excluded if the defect has resulted from an accident not attributable to Fujitsu Mikroelektronik GmbH, or abuse or misapplication attributable to the customer or any other third party not relating to Fujitsu Mikroelektronik GmbH.
3. To the maximum extent permitted by applicable law Fujitsu Mikroelektronik GmbH disclaims all other warranties, whether expressed or implied, in particular, but not limited to, warranties of merchantability and fitness for a particular purpose for which the Product is not designated.
4. To the maximum extent permitted by applicable law, Fujitsu Mikroelektronik GmbH's and its suppliers' liability is restricted to intention and gross negligence.

NO LIABILITY FOR CONSEQUENTIAL DAMAGES

To the maximum extent permitted by applicable law, in no event shall Fujitsu Mikroelektronik GmbH and its suppliers be liable for any damages whatsoever (including but without limitation, consequential and/or indirect damages for personal injury, assets of substantial value, loss of profits, interruption of business operation, loss of information, or any other monetary or pecuniary loss) arising from the use of the Product.

Should one of the above stipulations be or become invalid and/or unenforceable, the remaining stipulations shall stay in full effect.

.

In many applications, exact time information is essential. Using a LF receiver for the German time standard DCF77 can be a simple, but effective solution for this problem. But how to decode the time-signal ? This application note shows how to connect a DCF77 receiver to a MB90678 using the input capture function.

The 1978 law on time standards defines legal time in Europe on the basis of “Coordinated World Time (UTC)” and gives the PTB (Physikalisch-technische Bundesanstalt, Germany) responsibility for the keeping and broadcasting of legal time. Legal time in Europe is either Middle European Time (Mitteleuropäische Zeit) : MEZ(D) = UTC(PTB) + 1h or Middle European Summer Time MESZ(D) = UTC(PTB) + 2h and is generated in the PTB Atomic Clock in Braunschweig. It is transmitted from a 50kW-transmitter in Mainflingen (near Frankfurt) on the frequency 77.5 kHz with a relative deviation of the carrier (averaged over a day) of $< 1^{-12}$. The signal is transmitted in a 24-hour continuous service. Short interruptions (of a few minutes) are possible because of servicing, when switching to a backup transmitter or antenna. Thunderstorms can cause longer interruptions to the service.

The carrier is amplitude-modulated with second marks. At the beginning of each second (with the exception of the 59th second of each minute), the carrier amplitude is reduced to 25% for the duration of either 100 or 200ms. The start of the carrier reduction marks the precise beginning of the second. The minute is marked by the absence of the previous second mark. It is possible to achieve accuracy better than 1ms at distances of several hundred kilometers around Frankfurt.

The transmission of the numerical values for minute, hour, day, weekday, month and year are BCD-encoded through the pulse duration modulation of the second marks. A second mark with duration 0.1s encodes a binary 0 and a duration of 0.2s encodes 1. The order of encoding is shown in diagram 1. In the case of transmission of MEZ, mark 18 has a duration of 0.2s and mark 17 a duration of 0.1s. If MESZ is being transmitted, this is reversed. Furthermore, an approaching transition from MEZ to MESZ or back is announced by extending mark 16 from 0.1 to 0.2s for one hour prior to the changeover.

Mark number	Encodes (0.1s = logic “0” ; 0.2s = logic “1”)
0	Minute, always 0
1-14	Reserved
15	0=Normal antenna, 1=backup antenna in use
16	1=Approaching change from MEZ to MESZ or back (1 hour before)
17,18	Time zone 0,1=MEZ; 1,0=MESZ
19	The leap second is encoded in this bit one hour prior to occurrence.
20	Start bit for encoded time, always 1
21-27	1, 2, 4, 8, 10, 20, 40 Minutes
28	P1 maintains even parity for marks 21-28
29-34	1,2,4,8,10,20 Hours
35	P2 maintains even parity for marks 29-35
36-41	Day in month (1, 2, 4, 8, 10, 20)
42-44	Day in week (1,2,4)
45-49	Month number (1, 2, 4, 8, 10)
50-57	Year (1, 2, 4, 8, 10, 20, 40, 80)
58	P3 maintains even parity for marks 36-58 There is no mark transmitted for the 59th second.

Diagram 1 : Encoding diagram

To obtain the code, any active antenna capable of receiving 77kHz and demodulating the signal can be used. Such devices can be purchased by a number of electronic distributors in Europe. To feed the signal into the microcontroller, the input capture unit (ICU) of the MB90670/5 series is purpose-built. This module detects rising or falling edges, measures timeslots and generates interrupts. The maximum capture accuracy is 250 ns.

Diagram 2 shows the example application using a FZD01020 active antenna connected to the input capture pin ASR1 of the MCU. The written demo software drives a dot matrix display connected to port 6 (see last issue of spectrum!) to show the actual time and date. Additionally the MCU sends the time-information via RS232 to a connected PC once the program is running. If the signal will not be received anymore, an internal timer (16-bit timer0) will continue to count the seconds up until the DCF77-signal is available again.

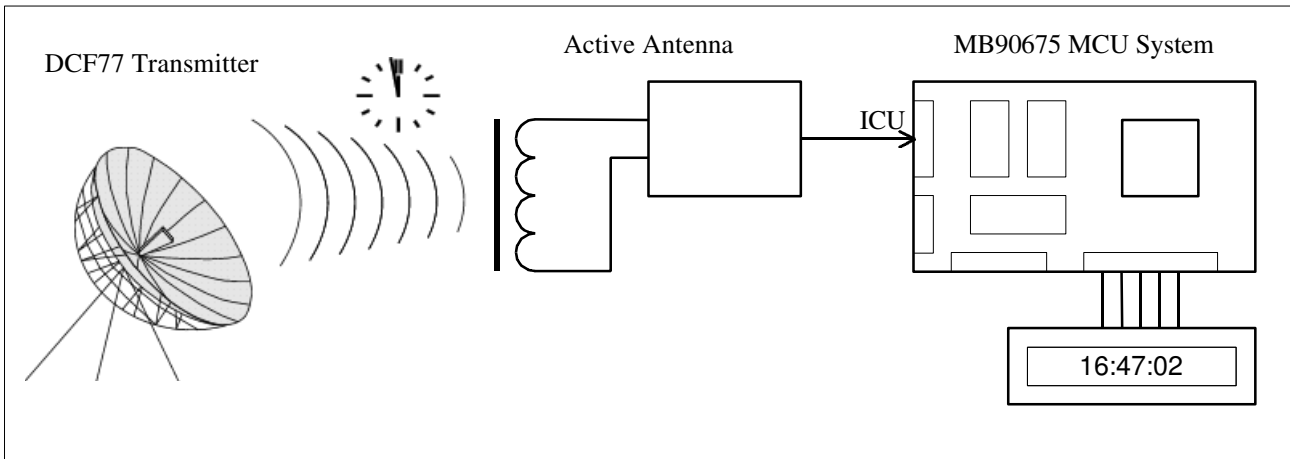

Diagram 2 : A simple time processing system using the MB90675

A system like this has many advantages compared to a normal quartz-based clock :

- very accurate time (+/- 1 second in 1 Mio. years!)
- can be a timebase for a whole computer network
- automatic recognition of MEZ and MESZ
- automatic recognition of leap years and minutes (!!!)
- easy to program accurate alarms over month

The input capture unit can be set up easily and then works independently from the CPU, so that a “decode-DFC77”-task can be run almost in the background of a main MCU-program. The MB90670/75 series feature four input capture units, so other applications needing edge detecting can be run simultaneously. For further information (democode etc.) please contact the MCU-group in FMG.

```

/*
*****
**
**          DFC77-CLOCK          **
**
** for MB90678 (16bit-Starterkit) **
** can be run with Emulator      **
**
** reads DFC77-Signal-Pulses via ICU1 (ASR1-Pin) **
** decodes the time signal and displays it on a LCD **
** connected to Port 6 (default-LCD-Type : LTN111) **
** (active antenna is FZD01020 by Channel Microelectronics **
** don't forget to add a pullup-resistor for signal-output **
** of antenna - it's an open-drain type)          **
**
** Author : Markus Mierse        **
** Version : 1 (backup timer for "no-signal"-case disabled) **
** Date   : 17.2.97              **
**
** (C) Fujitsu Mikroelektronik GmbH 1997          **
**
*****
*/

```

```
#include <sample\extn\mb90675.h>      /* for all Register Names */
```

```
/*----- variables -----*/
```

```

typedef unsigned char BYTE;    /* BYTE definition */

int cursor;                    /* display position */

int i;                          /* general purpose integer variable */
int counter;                   /* counter for timer 0 */
int index;                     /* index (0-58) of time protocol */
int begin;                     /* 1 if begun to decode */

int min;                       /* update time and date variables */
int hr;
int day;
int dow;
int month;
int year;

int sec;                       /* actual time and date */
int minr;
int hrr;
int dayr;
int dowl;
int monthr;
int yearr;

long int puls;                 /* pulswidth of received signal */
long int dist;                 /* distance from last puls */
long int t1;                   /* pulsvariable */

```

```
/*----- prototypes -----*/
```

```

void Init_Timer16(void);       /* init timer routine */
void Init_ICU(void);          /* init ICU */
void decode(void);           /* decode-routine */
void Init_Timer24(void);      /* init 24-bit-timer routine */

__interrupt
void Timer16(void);           /* ISR for timer0 */

__interrupt
void Timer24of(void);         /* ISR for 24-bit timer overflow */

__interrupt
void ICU1(void);             /* ISR for ICU1 */

void initdisp(void);         /* display routines */
void outb(unsigned char);
void busy(void);
void print(char *Name2);
void printnum(int n);
void printtime(int h,int m,int s);
void printdate(int dw,int dr,int mr, int yr);
void wait(int i);

```

```

/*-----*/
/*                               MAIN PROGRAM                               */
/*-----*/

void main(void)
{
    initdisp();           /* setup display on port 6 */
    print("DFC77-TIMER"); /* show header */

/*  Init_Timer16();      /* init 16-bit timer 0 (disabled) */

    Init_Timer24();      /* init 24-bit timer */
    Init_ICU();          /* init ICU */

    dist = 0;           /* init variables */
    begin = 0;
    i = 0;
    minr = 0;
    hrr = 0;
    sec = 0;
    dayr = 0;
    dowr = 0;
    monthr = 0;
    yearr = 0;

#pragma asm
    MOV     ILM, #7      ; allow all interrupts with level<7
    OR     CCR, #H'40   ; enable interrupts
#pragma endasm

    while(1);          /* dummy loop (wait for interrupt)*/
}

/*----- function bodies -----*/

/*-----*/
/* Initial Routine for ICU : This routine sets the ICU0 as input */
/*-----*/

void Init_ICU(void)
{
    ICR07 = 6;         /* INT level 6 for ICU interrupt */

    ICC_IRE0 = 0;     /* 1=Interrupt enable for ICU#0..3 */
    ICC_IRE1 = 1;
    ICC_IRE2 = 0;
    ICC_IRE3 = 0;

    ICC_IRO = 0;     /* Interrupt request (set to 0) */
    ICC_IR1 = 0;
    ICC_IR2 = 0;
    ICC_IR3 = 0;

    ICC_EG0 = 0;     /* detect : 0=no edges, 1=rising edges */
    ICC_EG1 = 1;     /*           2=falling or 3=both edges */
    ICC_EG2 = 0;
    ICC_EG3 = 0;
}

```

```

/*-----*/
/* Interrupt Service Routine : Input capture unit 1 (Pin P65) */
/*-----*/
__interrupt
void ICU1(void)
{
    ICC_IR1 = 0; /* clear interrupt request */
    if (ICC_EG1 == 1) /* If rising edge was detected */
    {
        dist = ((ICR1 - t1) / 10000); /* measure distance from last puls */
        ICC_EG1 = 2; /* detect falling edge now */
        TCCR_CLR = 0; /* reset 24-bit-timer */
    }
    else /* If falling edge was detected */
    {
        t1 = ICR1;
        puls = (t1 / 1000); /* puls : 400..500=100ms ; 800..900=200ms */
        if ((puls > 400) && (puls < 500)) /* 0 received (100ms) */
        {
            if (dist < 700) /* within normal protocol ? */
            {
                sec++; /* next second */
                if ((sec == 10) || (sec == 20) || (sec == 30) || (sec == 40) || (sec == 50))
                    printdate(dowr,dayr,monthr,yearr); /* show date every 10 seconds */
                else
                    printtime(hrr,minr,sec); /* show time */
                if (begin == 1) /* if tracing protocol */
                {
                    index++; /* increase mark */
                    if (index == 58) /* protocol finished ? */
                    {
                        hrr = hr; /* update time & date */
                        minr = min;
                        dayr = day;
                        dowr = dow;
                        monthr = month;
                        yearr = year;
                    }
                }
            }
            else /* begin of protocol and new minute */
            {
                begin = 1;
                index = 0;
                sec = 0;
                hr = 0;
                min = 0;
                day = 0;
                dow = 0;
                month = 0;
                year = 0;
            }
        }
        if ((puls > 800) && (puls < 900)) /* 1 received */
        {
            if (dist < 700) /* within normal protocol ? */
            {
                sec++; /* next second */
                if ((sec == 10) || (sec == 20) || (sec == 30) || (sec == 40) || (sec == 50))
                    printdate(dowr,dayr,monthr,yearr); /* show date every 10 seconds */
                else
                    printtime(hrr,minr,sec); /* show time */
                if (begin == 1) /* tracing marks ? */
                {
                    index++; /* increase mark */
                    decode(); /* decode protocol */
                    if (index == 58) /* protocol finished ? */
                    {
                        hrr = hr; /* update time & date */
                        minr = min;
                        dayr = day;
                        dowr = dow;
                        monthr = month;
                        yearr = year;
                    }
                }
            }
            else
            {
                begin = 0; /* WRONG ! Do not begin to decode */
                sec = 0;
            }
        }
        ICC_EG1 = 1; /* detect raising edge again */
    }
}

```



```

/*-----*/
/* Decode : This procedure decodes the puls-code into time & date*/
/* currently no parity-check (marks 28,35,58), no additional */
/* information (backup antenna, time zone etc) */
/*-----*/

void decode(void)
{
  switch(index)
  {
    case 21: {min++; break;} /* 21-27 minutes */
    case 22: {min = min + 2; break;}
    case 23: {min = min + 4; break;}
    case 24: {min = min + 8; break;}
    case 25: {min = min + 10; break;}
    case 26: {min = min + 20; break;}
    case 27: {min = min + 40; break;}
    case 29: {hr++; break;} /* 29-34 hours */
    case 30: {hr = hr + 2; break;}
    case 31: {hr = hr + 4; break;}
    case 32: {hr = hr + 8; break;}
    case 33: {hr = hr + 10; break;}
    case 34: {hr = hr + 40; break;}
    case 36: {day++; break;} /* 36-41 day in month */
    case 37: {day = day + 2; break;}
    case 38: {day = day + 4; break;}
    case 39: {day = day + 8; break;}
    case 40: {day = day + 10; break;}
    case 41: {day = day + 20; break;}
    case 42: {dow++; break;} /* 42-44 day in week */
    case 43: {dow = dow + 2; break;}
    case 44: {dow = dow + 4; break;}
    case 45: {month++; break;} /* 45-49 month */
    case 46: {month = month + 2; break;}
    case 47: {month = month + 4; break;}
    case 48: {month = month + 8; break;}
    case 49: {month = month + 10; break;}
    case 50: {year++; break;} /* 50-57 year */
    case 51: {year = year + 2; break;}
    case 52: {year = year + 4; break;}
    case 53: {year = year + 8; break;}
    case 54: {year = year + 10; break;}
    case 55: {year = year + 20; break;}
    case 56: {year = year + 40; break;}
    case 57: {year = year + 80; break;}
  }
}

/*-----*/
void Init_Timer24(void) /* init free run timer */
{
  ICR06 = 6; /* INT level 6 */

  TCCR_STP = 0; /* stop timer */

  TCCR_CLR = 0; /* 0=clear timer */
  TCCR_PRO = 0; /* 0=select clock : PLL/4 */
  TCCR_IVF = 0; /* 0=clear interrupt request */
  TCCR_IVFE = 1; /* 1=enable overflow INT */
  TCCR_TIM = 0; /* 0=clear interrupt request */
  TCCR_TIME = 0; /* 1=enable bit interm. INT */
  TCCR_TIS1 = 0; /* 01=set bit period to 1024us */
  TCCR_TIS0 = 1;

  /* TCCR_STP = 1; /* start timer (disabled) */
}

/*-----*/
/* Interrupt Service Routine : 24-bit timer overflow */
/* occurs every 4.1 seconds */
/* currently only used to indicate that no signal is available */
/*-----*/

__interrupt
void Timer24of(void)
{
  TCCR_IVF = 0; /* clear int request */
  /* occurs every 4.194 seconds */

  print("NO DFC-SIGNAL..."); /* show error message */
}

```

```

/*-----*/
/* Initial Routine for 16-bit timer0 : This routine sets the */
/* control register bits for reload-timer use and writes the */
/* appropriate value to the reload-register dep. on clock speed */
/*-----*/

void Init_Timer16(void)
{
    ICR09 = 6;                /* INT level 6 for timer interrupt */

    TMCSSR0_CSL1 = 1;        /* Clock : 00 = PLL/2 (with 16MHz = 0.125us) */
    TMCSSR0_CSLO = 0;        /* 01 = PLL/8 (0.5us) ; 10 = PLL/32 (2us) */
    TMCSSR0_MOD2 = 0;        /* 000 = Input trigger pin disabled */
    TMCSSR0_MOD1 = 0;
    TMCSSR0_MOD0 = 0;
    TMCSSR0_OUTE = 0;        /* 0 = TOUT-pin disabled */
    TMCSSR0_OUTL = 0;        /* 0 = TOUT-pin output level */
    TMCSSR0_RELD = 1;        /* 1 = reload timer; 0 = one shot timer */
    TMCSSR0_INTE = 1;        /* 1 = Interrupt enable */
    TMCSSR0_UF = 0;          /* 0 = Underflow Interrupt disable */
    TMCSSR0_CNTE = 1;        /* 1 = timer enable - wait for trigger */

    TMRLR0 = 50000;          /* Reload-value for 16 MHz-clock source */

    TMCSSR0_TRG = 1;        /* Trigger : ...Go ! */

}

/*-----*/
/* Interrupt Service Routine : 16-bit timer 0 */
/* occurs every second - counts seconds up when no signal is */
/* available. Currently disabled... */
/*-----*/
__interrupt
void Timer16(void)
{
    TMCSSR0_UF = 0;          /* clear int request */

    counter++;
    if (counter == 10)        /* 10 * 100msec = 1s */
    {
        if (begin == 0) {sec++;} /* increase second only if no signal */

        if (sec == 60)        /* check beginning of new min, hour */
        {
            sec = 0;
            minr++;
            if (minr == 60)
            {
                minr = 0;
                hrr++;
                if (hrr == 24)
                {
                    hrr = 0;
                }
            }
        }
    }

    /* every 10 seconds display date for one second */

    if ((sec == 10) || (sec == 20) || (sec == 30) || (sec == 40) || (sec == 50))
    {
        printdate(dowr, dayr, monthr, yearr);
    }
    else
    {
        printtime(hrr, minr, sec);
    }
    counter = 0;
}
}

```

```

/*-----*/
/* Display routines (Display LTN111 connected to port 6) */
/*-----*/

void initdisp(void)          /* This Routine initializes the LCD on port6 */
{
    DDR6=0x0DF;             /* Port 6 Output except P65 (ICU1 !) */
    PDR6=0;                 /* Port 6 Off*/

    PDR6=0x013;             /* Startup sequence */
    PDR6=0x03;
    wait(1000);
    PDR6=0x013;
    PDR6=0x03;
    wait(1000);
    PDR6=0x013;
    PDR6=0x03;
    wait(1000);
    PDR6=0x012;
    PDR6=0x02;

    outb(0x028);            /* Switch to 4-bit mode */
    outb(0x0C);             /* Cursor Off (on=0x0F) */
    outb(0x06);            /* No shift */
    outb(0x03);            /* Cursor home */
    outb(0x01);            /* Display clear */
}

void outb(unsigned char a)  /* send one byte to the display */
{
    BYTE b;

    cursor++;
    if (cursor == 9)
    {
        PDR6=0x01C;         /* correct position !LNT111-R only!*/
        PDR6=0x00C;
        PDR6=0x010;
        PDR6=0;
        busy();
    }
    b=(a & 0x0F0);          /* shift upper nibble */
    b = b >> 4;             /* to lower nibble */
    if (a & 0x080) {b=(b | 0x080);};
    /* but keep Bit 7 */
    b=(b & 135);           /* set other bits to zero */
    b=(b | 16);            /* set E line */
    PDR6=b;                /* send to LCD */
    b=(b & 135);           /* clear E line */
    PDR6=b;                /* send to LCD */
    b=(a & 143);           /* take lower nibble */
    b=(b | 16);            /* set E line */
    PDR6=b;                /* send to LCD */
    b=(b & 143);           /* clear E line */
    PDR6=b;                /* send to LCD */
    busy();                /* wait for busy-line */
}

void busy(void)             /* This Routine polls the busy-line */
{
    BYTE b;
    PDR6=0;                 /* Port 3 Off before reading ! */
    b=1;
    while (b)               /* wait for Busy-line */
    {
        DDR6=0x0D0;         /* set Bus as input to read Bit .3 (Busy) */
        PDR6=0x05F;         /* busy request */
        b=PDR6_PD63;        /* read Port */
        PDR6_PD64 = 0;
        PDR6_PD64 = 1;     /* toggle E */
        PDR6_PD64 = 0;
        PDR6_PD66 = 0;
        DDR6=0x0DF;        /* reset Port to output */
    }
}

```

```

void print(char *Name2)          /* This Routine displays a String */
{
    unsigned char c;
    BYTE b;
    int l,l;
    outb(1);                      /* Display clear */
    l=strlen(Name2);
    cursor=0;
    for (i=0; i<l; i++)          /* go through string */
    {
        c=(Name2[i]);           /* pick char */
        b=(c | 128);
        outb(b);                /* and display it */
    }
}

void printnum(int n)            /* show integer value on LCD display */
{
    float x;
    int l;
    if (n < 10)                  /* only one digit value */
    {
        outb(0x0b0);
        outb(0x0b0);
        outb((n+48) | 128);
    }
    else if (n >= 10 && n<100)   /* two digit value */
    {
        outb(0x0b0);
        outb(((n/10)+48) | 128);
        x = n-(10*(n / 10));
        l = x;
        outb((l+48) | 128);
    }
    else if (n >= 100)          /* show three digits */
    {
        outb(((n/100)+48) | 128);
        x = n-(100*(n / 100));
        n = x;
        outb(((n/10)+48) | 128);
        x = n-(10*(n / 10));
        l = x;
        outb((l+48) | 128);
    }
}

void printdate(int dw,int dr,int mr, int yr) /* show date on LCD display */
{
    float x;
    int l;

    outb(1);                      /* Display clear */

    switch(dw)                    /* display day of week */
    {
        case 1:{outb(77 | 128); outb(79 | 128); break;} /* MO */
        case 2:{outb(84 | 128); outb(85 | 128); break;} /* TU */
        case 3:{outb(87 | 128); outb(69 | 128); break;} /* WE */
        case 4:{outb(84 | 128); outb(72 | 128); break;} /* TH */
        case 5:{outb(70 | 128); outb(82 | 128); break;} /* FR */
        case 6:{outb(83 | 128); outb(65 | 128); break;} /* SA */
        case 7:{outb(83 | 128); outb(85 | 128); break;} /* SU */
    }
    outb(32 | 128);

    if (dr < 10)                  /* day in month : only one digit value */
    {
        outb(0x0b0);
        outb((dr+48) | 128);
    }
    else if (dr >= 10 && dr<100) /* two digit value */
    {
        outb(((dr/10)+48) | 128);
        x = dr-(10*(dr / 10));
        l = x;
        outb((l+48) | 128);
    }

    outb(46 | 128);

    if (mr < 10)                  /* month : only one digit value */

```

```

    {
        outb(0x0b0);
        outb((mr+48) | 128);
    }
else if (mr >= 10 && mr<100)    /* two digit value */
    {
        outb(((mr/10)+48) | 128);
        x = mr-(10*(mr / 10));
        l = x;
        outb((l+48) | 128);
    }

    outb(46 | 128);

    if (yr < 10)                /* year : only one digit value */
    {
        outb(0x0b0);
        outb((yr+48) | 128);
    }
else if (yr >= 10 && yr<100)    /* two digit value */
    {
        outb(((yr/10)+48) | 128);
        x = yr-(10*(yr / 10));
        l = x;
        outb((l+48) | 128);
    }
}

void printtime(int h,int m,int s)    /* show time on LCD display hh:mm:ss */
{
    float x;
    int l;
    outb(1);                    /* Display clear */

    if (h < 10)                /* hours : only one digit value */
    {
        outb(0x0b0);
        outb((h+48) | 128);
    }
else if (h >= 10 && h<100)    /* two digit value */
    {
        outb(((h/10)+48) | 128);
        x = h-(10*(h / 10));
        l = x;
        outb((l+48) | 128);
    }

    outb(58 | 128);

    if (m < 10)                /* minutes : only one digit value */
    {
        outb(0x0b0);
        outb((m+48) | 128);
    }
else if (m >= 10 && m<100)    /* two digit value */
    {
        outb(((m/10)+48) | 128);
        x = m-(10*(m / 10));
        l = x;
        outb((l+48) | 128);
    }

    outb(58 | 128);

    if (s < 10)                /* seconds : only one digit value */
    {
        outb(0x0b0);
        outb((s+48) | 128);
    }
else if (s >= 10 && s<100)    /* two digit value */
    {
        outb(((s/10)+48) | 128);
        x = s-(10*(s / 10));
        l = x;
        outb((l+48) | 128);
    }
}

/*-----*/
void wait(int i)
{
    for (; i ; i--);    /* very simple delay loop */
}
/*-----*/

```