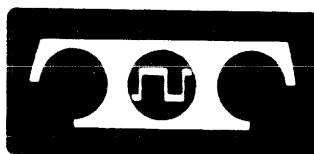




BULLETIN 1149B

PARTS

MODEL 28  
PAGE PRINTER SET  
(KSR & RO)



**TELETYPE<sup>®</sup>**  
CORPORATION

5555 TOUHY AVENUE, SKOKIE, ILLINOIS



BULLETIN 1149B

PARTS

MODEL 28  
PAGE PRINTER SET  
(KSR & RO)



**TELETYPE<sup>®</sup>**  
CORPORATION

5555 TOUHY AVENUE, SKOKIE, ILLINOIS

© 1953 and 1961 by Teletype Corporation in the United States.  
Copyright in all countries participating in International Con-  
vention and Pan American Conventions. All rights reserved  
including rights of translation into all languages.  
© 1963 by Teletype Corporation. All rights reserved.

Printed in U.S.A.

## LIST OF EFFECTIVE PAGES

CHANGE 12 - APRIL, 1963

(Supersedes January, 1962 Issue)

Page Number	Change In Effect	Page Number	Change In Effect
A	Change 12	3-78 to 3-82	Change 9
B	Change 12	3-83	Change 11
C to E	Change 11	3-84 to 3-86	Change 9
F to I	Change 12	3-87	Change 11
J to K	Change 11	3-88 to 3-92	Change 9
L to P	Change 10	3-93 to 3-105	Change 11
Q	Change 12	4-1 to 4-2	Change 9
1-1 to 1-5	Change 9	4-3 to 4-4	Change 11
1-6	Change 11	4-5	Change 9
1-7 to 1-13	Change 9	4-6	Change 11
1-14 to 1-15	Change 11	4-7 to 4-8	Change 9
1-16 to 1-27	Change 9	4-9 to 4-10	Change 11
1-28 to 1-29	Change 11	5-1	Change 9
1-30 to 1-31	Change 9	5-2 to 5-4	Change 11
1-32	Change 11	5-5 to 5-6	Change 9
2-1	Change 9	5-7	Change 11
2-2	Change 10	5-8 to 5-9	Change 9
2-2A to 2-3	Change 11	5-10	Change 11
2-4 to 2-6	Change 9	5-11 to 5-13	Change 9
2-7	Change 11	5-14	Change 11
2-8	Change 9	5-15 to 5-16	Change 9
2-9	Change 11	5-17	Change 10
2-10 to 2-12	Change 9	5-18 to 5-23	Change 9
2-13 to 2-14	Change 11	5-24	Change 10
2-15 to 2-20	Change 9	5-25 to 5-32	Change 9
2-21 to 2-31	Change 11	5-33	Change 11
3-1	Change 9	5-34 to 5-38	Change 9
3-2	Change 10	5-39	Change 11
3-3 to 3-18	Change 9	5-40	Change 10
3-19	Change 11	5-41 to 5-43	Change 11
3-20 to 3-21	Change 9	5-44	Change 10
3-22	Change 11	5-45	Change 11
3-23	Change 9	5-46 to 5-48	Change 10
3-24	Change 10	5-49 to 5-61	Change 11
3-25 to 3-30	Change 9	6-1 to 6-2	Change 9
3-31	Change 11	6-3	Change 11
3-32	Change 9	6-4 to 6-5	Change 9
3-33	Change 11	6-6	Change 11
3-34	Change 9	6-7 to 6-19	Change 9
3-35	Change 11	6-20	Change 11
3-36 to 3-41	Change 9	6-21 to 6-26	Change 9
3-42 to 3-44	Change 11	6-27 to 6-28	Change 10
3-45 to 3-46	Change 9	6-29 to 6-33	Change 11
3-47	Change 11	7-1 to 7-2	Change 9
3-48	Change 9	7-3	Change 11
3-49	Change 11	7-4 to 7-5	Change 9
3-50 to 3-51	Change 9	7-6 to 7-7	Change 11
3-52	Change 10	7-8 to 7-10	Change 9
3-53 to 3-55	Change 11	7-11	Change 11
3-56 to 3-57	Change 9	7-12 to 7-17	Change 9
3-58	Change 11	7A-1 to 7A-19	Change 12
3-59 to 3-76	Change 9	8-1	Change 9
3-77	Change 11	8-2 to 8-17	Change 11

The above list indicates the effective pages as of issue date. Upon receipt of Change Pages, insert them numerically and discard any superseded pages.

The MODEL 28 PAGE PRINTER SET (KSR & RO) . . . . . is made up of a group of basic component units in various combination. These include a keyboard or base, typing unit, motor unit, electrical service unit, distributor (optional) and cabinet or cover. The following chart lists the bulletins covering the components of the KSR & RO Sets: P-parts ordering information, A & L-adjustments and lubrication and D & T-description and principles of operation. (Bell System refer to standardized A & L information).

BASIC UNITS	CODES DESCRIPTIONS	BULLETINS		
		P	D & T	A & L
PAGE PRINTER	• LP Typing Unit	1149B	216B	217B
KEYBOARD	• LK Send-Receive Keyboard			
BASE	• LB Receiving Only Base			
MOTOR	• LMU Motor Unit			
ELECTRICAL SERVICE UNIT	• LESU Electrical Service Unit			
KEYTOPS AND TYPEPALLETS	Miscellaneous Keytops and Murray and Gothic Style Pallets	1164B	---	---
DISTRIBUTOR	LD Multiple Wire Distributor	1159B	234B	
COVER OR CABINET	• LAC Table Model or Floor Model Console Cabinet • LPC Skin Tight Cover (Table or Rack Mounted) • LBAC Stack Mounted Printer Cabinet	1149B	216B	217B
PAPER WINDER	PW and LPW Paper Winder	1129B	---	Note 2

• Parts ordering information for these components is covered in this bulletin.

NOTES:

1. Installation instructions covering a typical KSR Set may be found in Specification 5759S.
2. Installation and adjustments covering the Paper Winder may be found in Specification 5148S.
3. Maintenance Tools - see Bulletin 1124B for ordering information.

PARTS PECULIAR TO WALL MOUNTED UNITS ARE SHOWN IN SECTION 7A



TABLE OF CONTENTS

Figure		Page	Figure		Page
SECTION 1 - MARK II BASE (LB), KEYBOARD (LK) AND VARIABLE FEATURES					
(For modification kits applicable to Mark II and Mark III Keyboards and Bases see Section 2)					
1-1	Keyboard or Base Mechanism	1-2	1-21	152911 Modification Kit to Provide Signal Line Breaking Mechanism - Less Switch (Mark II Base)	1-18
1-2	Keyboard and Base Cables	1-3		152344 Modification Kit to Provide Signal Line Breaking Mechanism (Mark II Base)	1-18
1-3	Code Bar Mechanism	1-4	1-22	152342 Modification Kit to Provide Local-Remote Switch (Mark II Base)	1-19
1-4	Function and Code Levers	1-5		154681 Modification Kit to Provide Print Suppression Switch (Mark II Base)	1-19
1-5	Intermediate Gear Mechanism	1-6	1-23	152338 Modification Kit to Provide Time Delay Mechanism (Mark II Keyboard or Base)	1-20
1-6	Intermediate Gear Mechanism	1-6	1-24	152918 Modification Kit to Provide Local Back Space Mechanism (Mark II Keyboard)	1-21
1-7	Carriage Return Mechanism	1-7	1-25	152916 Modification Kit to Provide Local Reverse Line Feed Mechanism (Mark II Keyboard)	1-22
1-8	Keyboard Lock and Local Line Feed Mechanism	1-7	1-26	Auxiliary Cables (Mark II Keyboard or Base)	1-23
1-9	Keyboard Mechanism	1-8	1-27	154783 Modification Kit to Equip a Keyboard with "Off-Line" Contacts	1-24
1-10	Base Mechanism	1-9	1-28	154783 Modification Kit to Equip a Keyboard with "Off-Line" Contacts	1-25
1-11	Signal Generator Mechanism	1-10	1-29	158359 Modification Kit to Provide Busy Key Switch (Mark II Base)	1-26
1-12	Signal Generator Mechanism	1-11	1-30	Tachometer and Governor Adjustment Linkage (Mark II Keyboard or Base)	1-27
1-13	Signal Generator Mechanism	1-12		Numerical Index	1-28
1-14	Signal Generator Mechanism	1-13			
1-15	Keylever Assemblies	1-14			
	Additional Keylever Assemblies	1-15			
1-16	152333 Modification Kit to Provide Electrical Signal Line Break Mechanism (Mark II Keyboard)	1-16			
	153902 Modification Kit to Provide Mechanical Signal Line Break Mechanism (Mark II Keyboard)	1-16			
1-17	151887 Modification Kit to Provide Repeat on Space Mechanism (Mark II Keyboard)	1-16			
1-18	Gear Sets	1-17			
1-19	152343 Modification Kit to Provide End-of-Line Switch Mechanism (Mark II Keyboard)	1-17			
1-20	152334 Modification Kit to Provide Paper Feed-Out Motor Starting Mechanism (Mark II Keyboard or Base)	1-18			

SECTION 2 - MARK III KEYBOARD (LK) AND VARIABLE FEATURES

2-1	Keyboard Base Mechanism	2-2	2-18	Old Style Repeat on Space Mechanism	2-16
2-1A	Keyboard Base for Remote Control Gear Shift Mechanism	2-2A	2-19	163775 Modification Kit to Provide Repeat on Space Mechanism	2-16
2-2	Function Bail Mechanism	2-3	2-20	154146 Modification Kit to Provide Local Back Space Mechanism	2-17
2-3	Intermediate Gear Mechanism	2-3	2-21	154145 Modification Kit to Provide Local Reverse Line Feed Mechanism	2-18
2-4	Keyboard Mechanism	2-4	2-22	164005 Modification Kit to Provide Universal Keyboard Switch Mechanism	2-19
2-5	Variable Features of Keyboard Mechanism	2-5	2-23	164660 Modification Kit to Provide Synchronous Pulsed Transmission (100 MA)	2-20
2-6	Code Bar Mechanism	2-6	2-24	162641 and 163359 Modification Kits to Provide Variable Speed Gear Shift Mechanism (Mark II and Mark III Keyboard and Base)	2-21
2-7	Universal Bail Mechanism	2-7	2-25	154142 Modification Kit to Provide Time Delay Mechanism	2-22
2-8	Bail Lock Mechanism	2-7	2-26	174410 Contact Box Assembly with RF Suppression-Polar Transmission	2-23
2-9	Signal Generator Frame Mechanism	2-8	2-27	Answer Back Mechanism	2-24
2-10	Signal Generator Shaft Mechanism	2-9	2-28	Answer Back Mechanism	2-25
2-11	Signal Generator Front Plate Mechanism	2-10	2-29	Uncoded Code Blade	2-26
2-12	Signal Generator Rear Plate Mechanism	2-11	2-30	Speed Shift Gear Bracket Assembly	2-27
2-13	154165 Contact Box Assembly with Arc Suppression - Neutral Transmission	2-12		Numerical Index	2-28
2-14	154225 and 162892 Contact Box Assemblies with RF Suppression - Neutral and Polar Transmission	2-13			
2-15	164926 Modification Kit to Provide Paper Winding Facilities for Send-Receive and Receive-Only Bases Mounted in an Apparatus Cabinet (Mark II and Mark III Keyboard and Base)	2-14			
2-16	154147 Modification Kit to Provide Local Paper Feed-Out Motor Starting Mechanism	2-15			
2-17	154141 and 164494 Modification Kits to Provide Electrical Signal Line Break Mechanism	2-15			

TABLE OF CONTENTS (Continued)

Figure		Page	Figure		Page
SECTION 3 - TYPING UNIT (LP) AND VARIABLE FEATURES					
3-1	Left Side Frame Mechanism	3-2	3-59	152312 Modification Kit to Convert Printer for Use with Lightweight Set	3-61
3-2	Right Side Frame Mechanism	3-3	3-60	152315 and 154743 Modification Kits to Provide Manual Selection of Stunt Box Operation	3-62
3-3	Left and Right Side Frames Mechanism	3-4	3-61	152317 Modification Kit to Provide Horizontal Tabulator XD Control	3-63
3-4	Left and Right Side Frames Mechanism	3-5	3-62	152337 and 157509 Modification Kits to Provide On-Line Stunt Shift Control	3-64
3-5	Pressure Roller Mechanism	3-6	3-63	152340 Modification Kit to Provide Multi-Copy Paper Handling	3-65
3-6	Pressure Roller Mechanism	3-7	3-64	152345 Modification Kit to Provide Off-Line Stunt Shift Control	3-66
3-7	Space Suppression Mechanism	3-8	3-65	152348 Automatic Carriage Return and Line Feed and 153945 "O" Code Bar and Bellcrank Modification Kits	3-67
3-8	Space Suppression Mechanism	3-9	3-66	152350 Modification Kit to Provide Keyboard Lock	3-68
3-9	Paper Spindle and Reset Bail Mechanism	3-10	3-67	153919 Modification Kit to Provide Auxiliary Connector	3-68
3-10	Paper Spindle and Reset Bail Mechanism	3-11	3-68	152915 and 157511 Modification Kits to Provide Local Reverse Line Feed	3-69
3-11	Reset Bail Mechanism	3-12	3-69	Sprocket Feed Paper Handling Modification Kits (Typing Unit and Cabinet)	3-70
3-12	Sprocket Feed Mechanism	3-13	3-70	153910 Modification Kit to Provide Function Suppression for "AZ" Stunt Box	3-71
3-13	Line Feed and Platen Mechanism	3-14	3-71	153911 Modification Kit to Provide Continuous Spacing	3-72
3-14	Left Side Linkage and Rocker Shaft Mechanism	3-15	3-72	153911 Modification Kit to Provide Continuous Spacing	3-73
3-15	Left Side Linkage and Stripper Blade Mechanism	3-16	3-73	154727 Modification Kit to Provide Auxiliary Connector	3-74
3-16	Right Side Linkage and Type Box Carriage Mechanism	3-17	3-74	153742 Modification Kit to Provide Four Lines Per Inch	3-75
3-17	Right Side Linkage and Type Box Carriage Mechanism	3-18	3-75	155051 Auxiliary Cable Assembly	3-76
3-18	Main Shaft Mechanism	3-19	3-76	154753 Modification Kit to Provide Auxiliary Connector	3-76
3-19	Main Shaft Mechanism	3-20	3-77	154755 Modification Kit to Provide Five Spaces Per Inch Horizontally	3-77
3-20	Line Feed Clutch and Function Clutch Mechanism	3-21	3-78	159395 Modification Kit to Provide Six Spaces Per Inch Horizontally	3-77
3-21	Trip Shaft Mechanism	3-22	3-79	154792 Modification Kit to Provide Twelve Spacer Per Inch Horizontally	3-77
3-22	Trip Shaft Mechanism	3-23	3-80	154760 through 154769 Modification Kits to Provide Vertical Tabulation	3-78
3-23	Spring Drum and Spacing Drum Mechanism	3-24	3-81	154770 Modification Kit to Provide Vertical Tabulation on Upper Case "J" and "Z"	3-79
3-24	Spring Drum and Spacing Mechanism	3-25	3-82	154778 Modification Kit to Provide External Pulse Shift Feature	3-80
3-25	Front Plate Mechanism	3-26	3-83	154778 Modification Kit to Provide External Pulse Shift Feature	3-81
3-26	Front Plate Mechanism	3-27	3-84	154780 Modification Kit to Provide Horizontal Tabulator XD Control	3-82
3-27	Front Plate Mechanism	3-28	3-85	154785 Modification Kit to Provide Universal Contact	3-83
3-28	Front Plate Mechanism	3-29	3-86	157508 Modification Kit to Provide Horizontal Tabulation	3-84
3-29	Front Plate Mechanism	3-30	3-87	157508 Modification Kit to Provide Horizontal Tabulation	3-85
3-30	Code Bar Positioning Mechanism	3-31	3-88	152917 and 157510 Modification Kits to Provide Local Backspace	3-86
3-31	Code Bar Positioning Mechanism	3-32	3-89	160886 Modification Kit to Provide Local Form Feed-Out	3-87
3-32	Selector Mechanism	3-33	3-90	163292 Modification Kit to Provide Eight Spaces Per Inch Mechanism	3-87
3-33	Selector Knob Mechanism	3-34	3-91	161280 Modification Kit to Provide On-Line Reverse Line Feed	3-88
3-34	Selector Magnet Mechanism	3-35	3-92	163183 Modification Kit to Provide D.C. Magnet Operated Print Suppression	3-89
3-35	Selector Magnet Mechanism	3-36	3-93	163947 Modification Kit to Provide Improved Manual Platen Line Feed	3-90
3-36	Right Ribbon Feed Mechanism	3-37	3-94	163535 Modification Kit to Provide Transmitter Control for the Vertical Tabulator	3-90
3-37	Left Ribbon Feed Mechanism	3-38	3-95	164270 Modification Kit to Provide Copy Display	3-91
3-38	Code Bar Mechanism	3-39	3-96	157514 Modification Kit to Provide Automatic Carriage Return and Line Feed	3-92
3-39	Code Bar Mechanism	3-40	3-97	172181 Modification Kit to Provide Copy Display	3-92
3-40	Printing Carriage Mechanism	3-41	3-98	163146 Modification Kit to Provide Universal Contact	3-93
3-41	Type Box and Pallets	3-42	3-99	159366 Modification Kit to Provide Paper-Out Alarm	3-94
3-42	Early Design Type Box and Pallets	3-43	3-100	179369** Modification Kit to Provide Copy Display	3-95
	Typepallet Chart	3-44	3-101	Selective Calling Function Lever Modification Kits	3-96
	Typepallet Chart	3-45		Numerical Index	3-97
3-43	Stunt Box (Major Components)	3-46			
3-44	Stunt Box (Major Components Variables)	3-47			
3-45	Shift Mechanism Components	3-48			
3-46	Stunt Box (Latching Components)	3-49			
3-47	Switch Assemblies and Components	3-50			
3-48	Switch Assemblies and Components	3-51			
3-49	Cable Assemblies	3-52			
3-50	Function Bars	3-53			
	Function Bar Condition Chart	3-54			
	Function Bar Condition Chart	3-55			
3-51	151799 Modification Kit to Provide Latches for Paper Spindle	3-56			
3-52	159362 Modification Kit to Provide Spacers for Centering Narrow Paper Roll on Spindle	3-56			
3-53	152302 Modification Kit to Provide Page Feed-Out on Upper Case "Z"	3-57			
3-54	152303 and 176821 Modification Kits to Provide Page Feed-Out Transmitter Control	3-58			
3-55	Modification Kits to Provide Page Feed-Out Form Length Gear and Disk	3-58			
3-56	152304 Modification Kit to Provide Horizontal Tabulation Mechanism	3-59			
3-57	152304 Modification Kit to Provide Horizontal Tabulation	3-60			
3-58	153912 Modification Kit to Provide FIGS. - LTRS. Code Bar Manual Shifting	3-61			

TABLE OF CONTENTS (Continued)

Figure		Page	Figure		Page
SECTION 4 - MOTOR UNIT (LMU)					
4-1	LMU3 Synchronous Motor Unit		4-2	154628 Governor Assembly	4-7
4-2	Series Motor	4-2	4-3	LMU21 Synchronous Motor Unit	4-8
4-3	150845 Governor Assembly	4-3	4-4	Series Motor Mounting Parts	4-9
4-4	Series Motor Mounting Parts	4-4	4-5	Numerical Index	4-10
4-5	Series Motor Mounting Parts with RF Suppression	4-5	4-6		

SECTION 5 - CABINETS (LAC AND LBAC) AND COVER (LPC) ARE VARIABLE FEATURES

5-1	LAC2-2** LAC203** LAC204** LAC213** LAC215** and LAC216** Cabinets	5-2	5-32	Variable Features for LPC204** and LPC205** Covers	5-28
5-2	Variable Features for LAC202** Cabinet	5-2	5-33	164345** Modification Kit to Equip an Electrical Service Unit with Auxiliary Terminal Blocks	5-29
5-3	Variable Features for LAC203** LAC204** LAC213** LAC215** and LAC216** Cabinets	5-3		164331 Modification Kit to Add Terminal Block and Cables for Selective Calling	5-29
5-4	152349** Modification Kit to Provide Paper Supply and Accumulating Shelf	5-4	5-34	LPC206** and LPC207** Covers	5-30
5-5	153901** Modification Kit to Provide Paper Winder Mounting Bracket	5-5	5-35	Variable Features for LPC206** and LPC207**	5-31
5-6	159373 Modification Kit to Provide Apparatus Mounting Rack	5-6	5-36	Variable Features for LPC207**	5-32
5-7	152300** Modification Kit to Provide Directory Holder	5-6	5-37	Cabinet Body Assembly (LBAC211**)	5-33
5-8	152910** Modification Kit to Provide Directory Holder	5-7	5-38	Slide Mechanism (LBAC211**)	5-34
5-9	153926 Modification Kit to Provide Sprocket Feed Rear Paper Guide	5-7	5-39	Send-Receive Keyboard Cover (LBAC211**)	5-34
5-10	152901** and 153900** Modification Kits to Provide Offset Copyholders	5-7	5-40	Relay Rack Frame Assembly (LBAC211**)	5-35
5-11	152902 Modification Kit to Equip A Cabinet with A Busy Lamp	5-8	5-41	Terminal Blocks and Cable Connectors (LBAC211**)	5-35
5-12	153920 and 154741 Modification Kits to Adapt A Cabinet for Selective Calling	5-9	5-42	Door Arm Mechanism (LBAC211**)	5-36
5-13	152319 Modification Kit to Provide Additional Terminal Connections on Cabinet	5-10	5-43	172700** Door Assembly (LBAC211**)	5-36
5-14	159357 Modification Kit to Provide 5.5 Volt A.C. Incandescent Copylight System	5-11	5-44	Receiving Only Base Plate (LBAC211**)	5-37
5-15	6 Volt A.C. Incandescent Copylight System	5-12	5-45	Paper Winder Shelf for Send-Receive Base (LBAC211**)	5-38
5-16	LAC205** Console Cabinet	5-13	5-46	Cabinet Body Assembly (LBAC227**)	5-39
5-17	Variable Features for LAC205** Console Cabinet	5-14	5-47	Panel Mounting Assembly (LBAC227**)	5-40
5-18	160224 Modification Kit to Add Open and Busy Line Indicator Lights	5-15	5-48	Cover Assembly (LBAC227**)	5-41
5-19	145278 and 154756 Modification Kits to Add Form-Out Mechanism to Console Cabinet	5-16	5-49	Slide Assemblies (LBAC227** and LBAC233**)	5-41
5-20	154793 Modification Kit to Add Shock Mounts to a Console Cabinet	5-17	5-50	Base Plate Assembly (LBAC227**)	5-42
5-21	154754** Modification Kit to Provide a Sub-Base for a Console Cabinet	5-18	5-51	Mounting Rack Assembly (LBAC227** and (LBAC233**)	5-43
5-22	154777 Modification Kit to Provide D.C. Incandescent Copylight System	5-19	5-52	145220 Modification Kit to Provide Key and Lamp Assembly	5-44
5-23	159375 Modification Kit to Convert and A.C. Copylight System to a 60 Volt D.C. Copylight System	5-20	5-53	144600 Modification Kit to Provide Key and Lamp Assembly	5-44
5-24	154641 Modification Kit to Add Signal Line Electrical Noise Suppressor	5-21	5-54	173097** Modification Kit to Provide Shelf for a Console Cabinet	5-45
5-25	151988 Modification Kit to Add Power Line Electrical Noise Suppressor	5-22	5-55	145450 Modification Kit to Provide Key and Lamp Assembly	5-46
5-26	159390 Modification Kit to Provide and Apparatur Mounting Rack in an LAC205** Console Cabinet	5-22	5-56	145010 Modification Kit to Provide Key and Lamp Assembly	5-46
5-27	163796** Modification Kit to Provide Shelf for a Console Cabinet	5-23	5-57	145017 Rectifier - 48 Volts D.C.	5-47
5-28	Cables for the LAC213** and LAC215** Cabinets	5-23	5-58	145070 Modification Kit to Provide Key and Lamp Assembly	5-48
5-29	LPC202** and LPC203** Covers	5-24	5-59	173238 Modification Kit to Add Ready Light to LAC Cabinet	5-49
5-30	Variable Features for LPC202** and LPC203** Covers	5-25	5-60	174458 Modification Kit to Provide LAC Cabinet with a Paper Tearing Plate	5-49
5-31	LPC204** and LPC205** Covers	5-26	5-61	178387 Modification Kit to Provide High Voltage Static Eliminator	5-50
		5-27	5-62	178897** Modification Kit to Provide Offset Copyholder	5-51
			5-63	176714 Modification Kit to Provide Low Paper and Paper Out Alarm	5-52
			5-64	Control Panel Assembly (LBAC233**)	5-53
			5-65	Keyboard Panel Assembly (LBAC233**)	5-53
			5-66	Top and Middle Cover Assemblies (LBAC233**)	5-54
			5-67	Bottom Cover Assembly (LBAC233**)	5-54
			5-68	Base Plate Assembly (LBAC233**)	5-55
			5-69	Electrical Service Assembly (LBAC233**)	5-56
				Numerical Index	5-57

## TABLE OF CONTENTS (Continued)

Figure		Page	Figure		Page
SECTION 6 - ELECTRICAL SERVICE UNIT (LESU) AND VARIABLE FEATURES					
6-1	Electrical Service Unit	6-2	6-20	155785 Cable Extension	6-18
6-2	Electrical Service Unit	6-3	6-21	159397 Modification Kit to Convert a 152623 Line Relay Mounting Assembly to a 160226 Assembly	6-18
6-3	Variables for Electrical Service Units	6-4	6-22	160966 Modification Kit to Provide Transmitter and Reperforator Control	6-19
6-4	151995 and 152330 Modification Kit to Add Line Pad Resistor	6-4	6-23	Variable Features for Electrical Service Unit	6-20
6-5	151400, 153040 and 153251 Electrical Motor Control Assemblies	6-5	6-24	Cable Assembly Chart	6-20
6-6	151999 and 152950 Rectifier and Cable Assemblies (120 MA)	6-6	6-25	162361 Rectifier and Cable Assembly (500 MA)	6-21
6-7	151882 Line Relay Mounting Assembly	6-7	6-26	163969 and 163697 Relay Panel Assemblies	6-22
6-8	152623 and 160226 Line Relay Mounting Assemblies	6-7	6-27	164503 Rectifier Assembly	6-23
6-9	152744 Line Test Key Assembly	6-8	6-28	164271 Electrical Service Assembly	6-24
6-10	162625 Line Test Key Assembly	6-9	6-29	173363 Modification Kit to Adapt a 164271 Electrical Service Assembly for use in an LBAC211** Cabinet	6-24
6-11	152021 Capacitor-Resistor Assembly	6-10	6-30	154732 and 154779 Modification Kits to Add a Relay Shift Unit to an Electrical Service Unit	6-25
6-12	152624 Capacitor-Resistor Assembly	6-11	6-31	152999 Filter and Bell Assembly	6-26
6-13	152332 Relay Motor Control Assembly	6-12	6-32	Electrical Service Unit	6-27
6-14	93073 Modification Kit to Add 1500 OHM Resistor	6-13	6-33	Electrical Service Units (Accessory Groups)	6-28
6-15	152331 Rectifier Assembly	6-14	6-34	176810 Answer Back Control Relay Assembly	6-29
6-16	157216 Line Relay Mounting Assembly	6-15	6-35	176694 (Motor Control) and 176698 (Slow Release) Relay Assemblies	6-29
6-17	160223 Auxiliary Cable Assembly	6-16		Numerical Index	6-30
6-18	155558 D.C. Control Relay Assembly	6-16			
6-19	154747 Modification Kit to Equip and Electrical Service Unit for Continuous Spacing	6-17			

## SECTION 7 - NOTES OF EXPLANATION, CONVERSION AND MODIFICATION KITS

## SECTION 7A - PECULIARITIES TO WALL MOUNTED UNITS

7A-1	Keyboard and Base Mechanism	7A-2	7A-11	194086 Modification Kit to Adapt Wall Mounted Printer for Selective Calling	7A-11
7A-2	Keyboard Mechanism	7A-3	7A-12	176985 Rectifier and Cable Assembly (500 MA)	7A-12
7A-3	Trip Lever Mechanism	7A-4	7A-13	178518 Motor Control Assembly	7A-13
7A-4	Ball Lock Mechanism	7A-5	7A-14	178507 Selector Magnet Driver Assembly	7A-14
7A-5	LMU27 Synchronous Motor Unit	7A-6	7A-15	Back Plate Assembly	7A-15
7A-6	Right and Left Side Frames	7A-7	7A-16	Wall Mounted Cabinet	7A-16
7A-7	Main Shaft Mechanism	7A-8	7A-17	Copyholder Tray, Hood and Front Plate	7A-17
7A-8	Sprocket Feed Paper Handling Modification Kits	7A-9		Numerical Index	7A-18
7A-9	Electrical Service Unit	7A-10			
7A-10	176921 Transformer and Relay Assembly				

## SECTION 8 - MASTER NUMERICAL INDEX

Components of the Model 28 PAGE PRINTER SET covered in this bulletin		
MARK II BASE		LB3, 4, 5, 8, 200**
MARK II KEYBOARD		LK3, 4, 5, 7
MARK III KEYBOARD		LK6, 8, 9, 10, 11, 12, 13, 14, 15, 16, 18, 19, 20, 22, 23, 25, 26, 29
MARK II TYPING UNIT	Friction Feed	LP3, 4, 5, 6, 8
	Sprocket Feed	LP7, 9
MARK III TYPING UNIT	Friction Feed	LP10, 12, 13, 14, 15, 16, 17, 18, 19, 20, 21, 23, 24, 25, 26, 27, 34, 35, 39, 40, 41, 42, 43, 45, 47, 49, 54, 59, 64, 65, 68, 76, 82, 99, 101, 103
	Sprocket Feed	LP11, 22, 28, 29, 30, 31, 32, 33, 36, 37, 38, 44, 46, 48, 50, 51, 52, 53, 55, 56, 57, 60, 61, 62, 63, 69, 70, 71, 72, 73, 78, 79, 80, 81, 83, 85, 86, 87, 88, 89, 92, 93, 100
MOTOR UNIT		LMU3, 4, 6, 10, 21, 28
ELECTRICAL SERVICE UNIT		LESU5, 6, 7, 8, 17, 26, 31, 41, 42, 45, 46, 58, 59, 67
CABINET	Table Model	LAC203**, 213**
	Console Model	LAC202**, 204**, 205**, 215**, 216**, 217**
	Stack Mounting	LBAC211**, 227**, 233**
SKIN TIGHT COVER		LPC202**, 203**, 204**, 205**, 206**, 207**

Components of the Model 28 WALL MOUNTED PAGE PRINTER SET covered in this bulletin		
BASE		LB31
KEYBOARD		LK27
TYPING UNIT	Friction Feed	LP96
	Sprocket Feed	LP95, 97, 102
MOTOR UNIT		LMU27
ELECTRICAL SERVICE UNIT		LESU72
SKIN TIGHT COVER		LPC209**, 210**

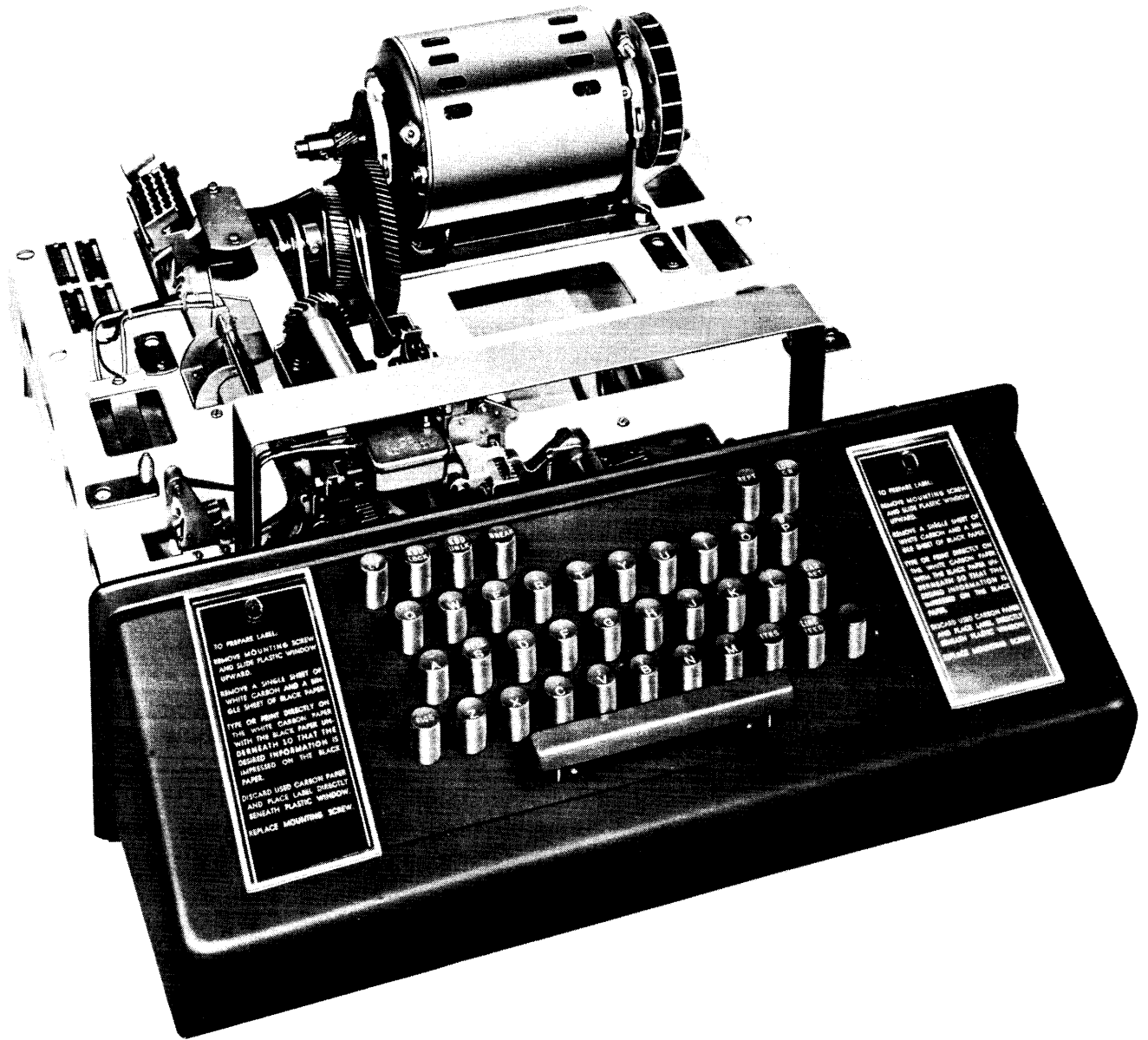
BELL SYSTEM AND TELETYPE CODE CROSS-REFERENCE					
Unit Description	Bell System Code	Teletype Code	Unit Description	Bell System Code	Teletype Code
BASE OR KEYBOARD	28A	LK3RC106	TYPING UNIT	28D	LP15RX/AR
	28B	LB4/146		28LA	LP18RA/AGN
	28B-1	LB4/218		28E	LP19RX/AN
	28L	LB31		28B-2	LP28RX/AES
	28C	LK5RC131		28B	LP28RX/AR
	28D	LK16ARC		28C	LP29RX/AEL
	28E	LK22BR5		28B-1	LP31WB/AX
	28G	LK26BRX		28F	LP32RX/AN
	28K	LK27ARC		28G	LP33RX/AEK
	28F	LB9/146		28J	LP41RX/AEG
MOTOR UNIT	28A	LMU3	28J-1	LP47RX/AEG	
	28B	LMU6	28H	LP49RX/AED	
	28LA	LMU21	28H-1	LP49RX/AFA	
ELECTRICAL SERVICE UNIT	28A	LESU5/102	28H-2	LP49RX/AFB	
	28B	LESU7/184	28K	LP49RX/AFC	
	28E	LESU7/134	28L	LP49RX/AFG	
	28E-1	LESU31	28Y	LP49RX/AGU	
	28LC	LESU58/256	28B	LP60RX/AFN	
	28LC-1	LESU58/257	28C	LP61RX/AFP	
	28LD	LESU59/256	28F	LP62RX/AFQ	
	28LD-1	LESU59/257	28G	LP63RX/AFW	
	28M	LESU67	28U	LP70RX/AGE	
	28T	LESU72	28W	LP71RX/AGF	
	CABINET	28A**	LAC202**107	28LD	LP80RA/AGP
		28B**	LAC204**240	28LE	LP81RA/AGP
		28C**	LAC203**241	28LB	LP82RA/AGQ
28D**		LAC204**250	28LC	LP82RA/AGR	
28E**		LAC203**238	28B	LP86RX/AGX	
28LB**		LAC215**	28C	LP87RX/AGY	
28J**		LAC216**	28F	LP88RX/AGZ	
28LA**		LBAC227**	28G	LP89RX/AHA	
COVER		28A**	LPC205**	28S	LP92RX/AHD
		28L**	LPC209**	28AA	LP93RX/AHE
	28M**	LPC210**	28AG	LP95RX/AGE	
60 WPM  GEAR SETS 75 WPM  100 WPM	28A	151060	28AJ	LP96RX/AR	
	28A-1	161293	28AE	LP97YK/AGE	
	28B	151075	28LF	LP100RA/AHL	
	28B-1	161294	28AH	LP102RX/AGE	
	28C	151100	TYPE BOX	28A	151930 (RA)
	28C-1	161295		28A-1	155701 (WY)
COPYHOLDER	28A**	152901**		28A-2	161362 (XR)
	28B**	153900**		28B	152881 (RB)
PAPER SUPPLY BOX	28A**	152349**		28B-1	161363 (XS)
				28C	151931 (RC)
				28C-1	161364 (XT)
				28D	151937 (RD)
				28D-1	157018 (WN)
				28D-2	161365 (XV)
			28E	155709 (XH)	
			28E-1	155693 (WP)	
			28F	154643 (RV)	
			28F-1	153518 (WA)	
			28G	164348 (YK)	
			28H	176651 (YP)	

BELL SYSTEM ONLY

When ordering parts from this bulletin, prefix each number with the letters TP.

PAINT FINISH COLOR CODE CHART				
(For Parts and Assemblies Requiring a Paint Finish)				
Color	Finish Suffixes			
	Wrinkle	Smooth	Textured Vinyl	Smooth Vinyl
Black	AA (37)	BB (34)		
Dark Brown	AD (39)			
Gray Green	AB (40)	BK	GA (45)	
Charcoal Gray	AL	BZ		HA
Dark Gray			GB	
Light Gray		EJ		HE
Beige Gray				HE
Light Beige		EL		HC
Moss Green		EN		HD
Eye Rest Green		EA		
Turquoise		EV		
Aqua Blue		EK		
Brussels Light Blue		EC		
Med. Blue		ES		
Cherry Red		EF		
Pastel Yellow		EG		
White		EH		
Ivory		EM		
Beige		ET		
Rose Beige		ER		
Rose Pink		EV		

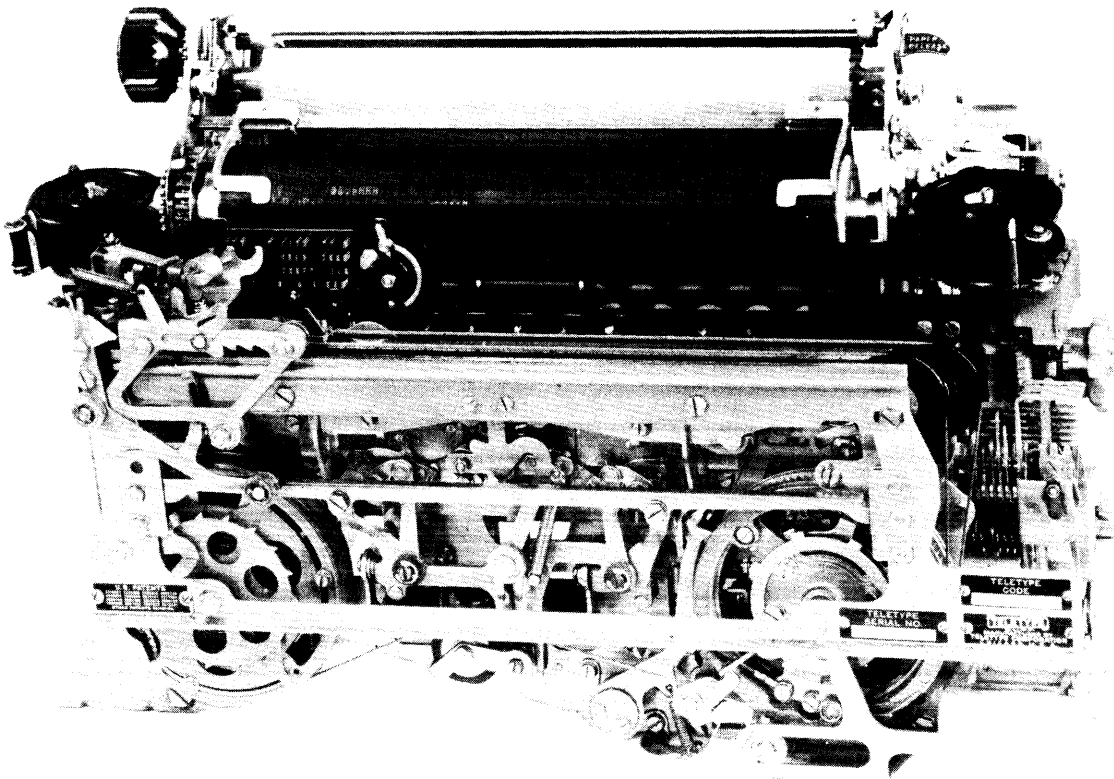
Numbers in parenthesis ( ) indicate BELL SYSTEM CODE.  
Suffix to be applied following the Part Number.



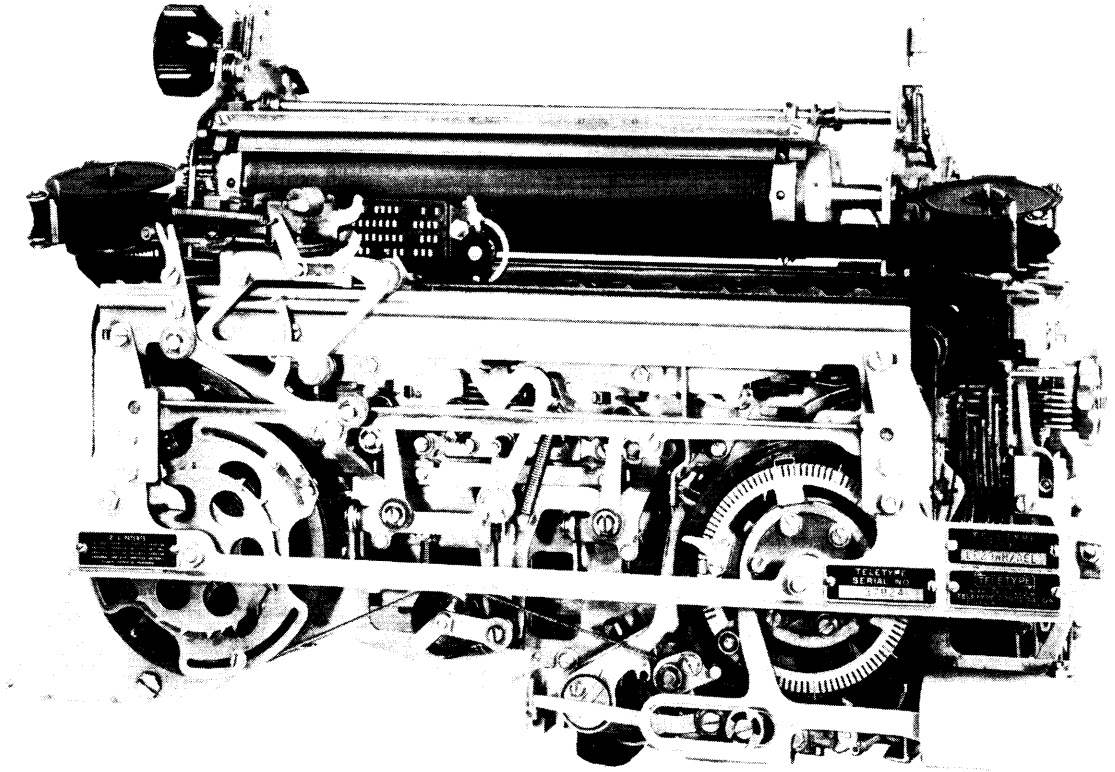
MODEL 28 KEYBOARD (LK) WITH MOTOR UNIT (LMU)



1149B

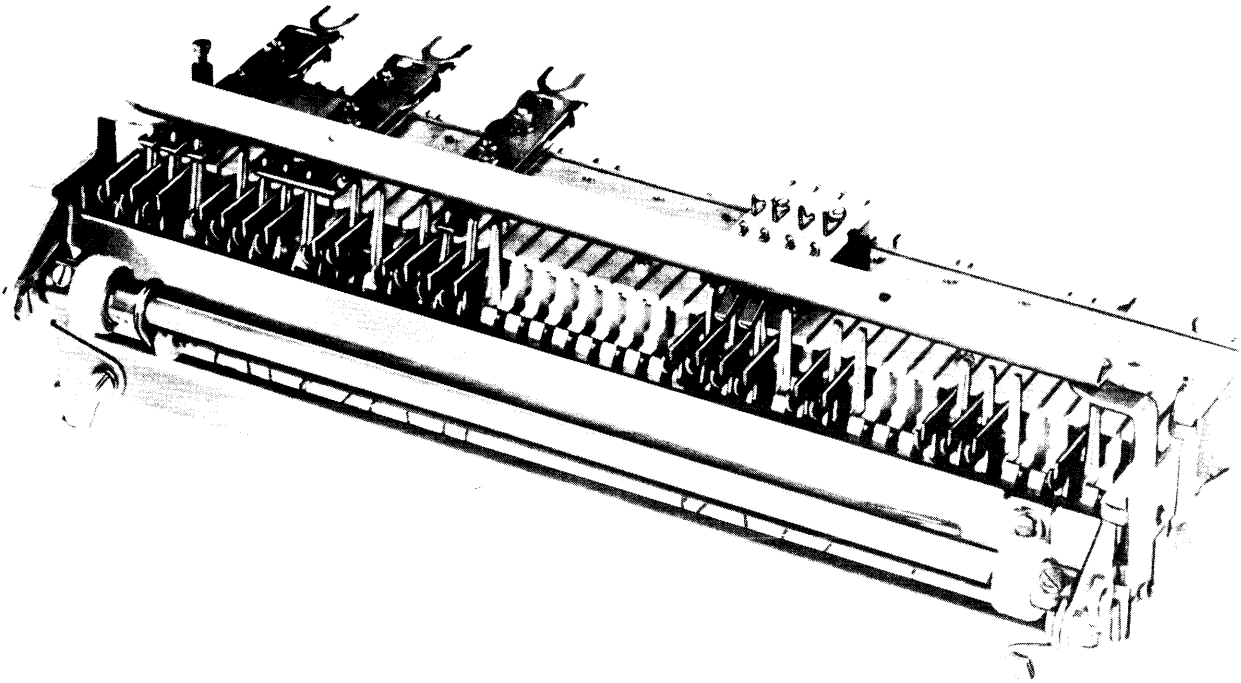


MODEL 28 FRICTION FEED TYPING UNIT (LP)



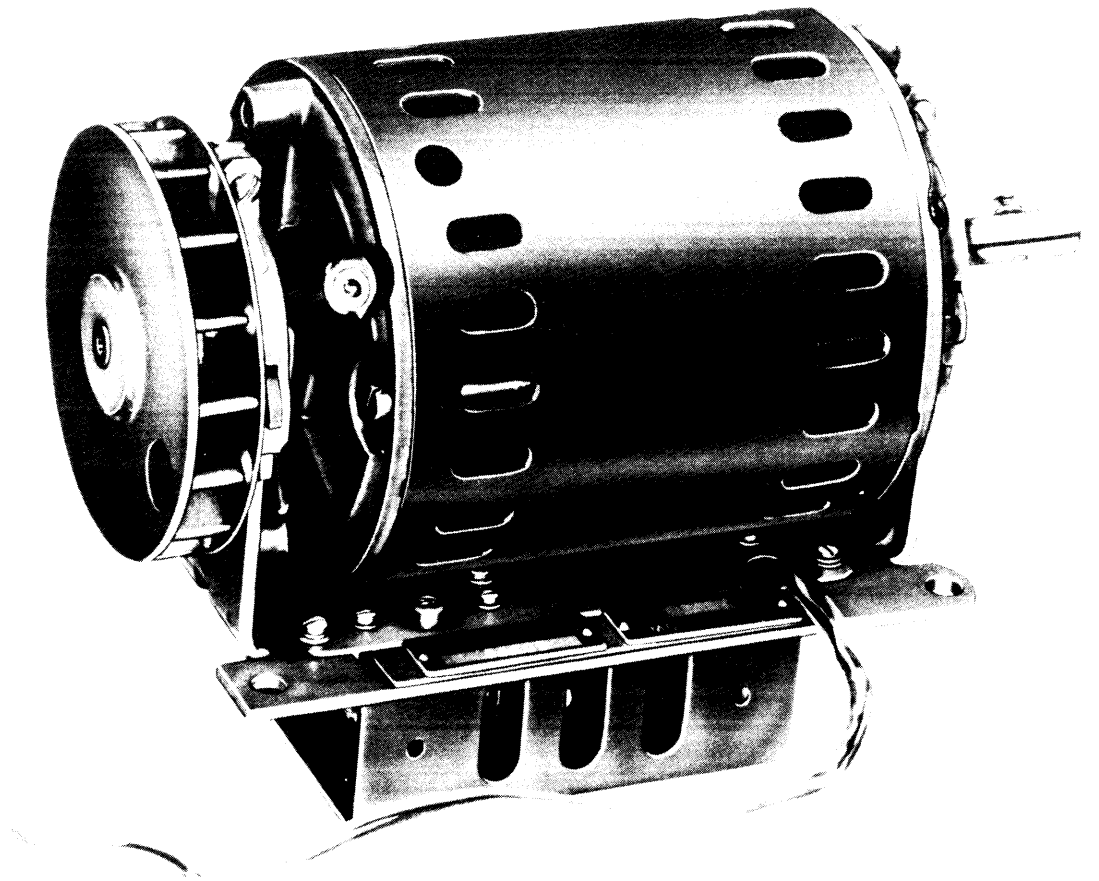
MODEL 28 SPROCKET FEED TYPING UNIT (LP)

1149B



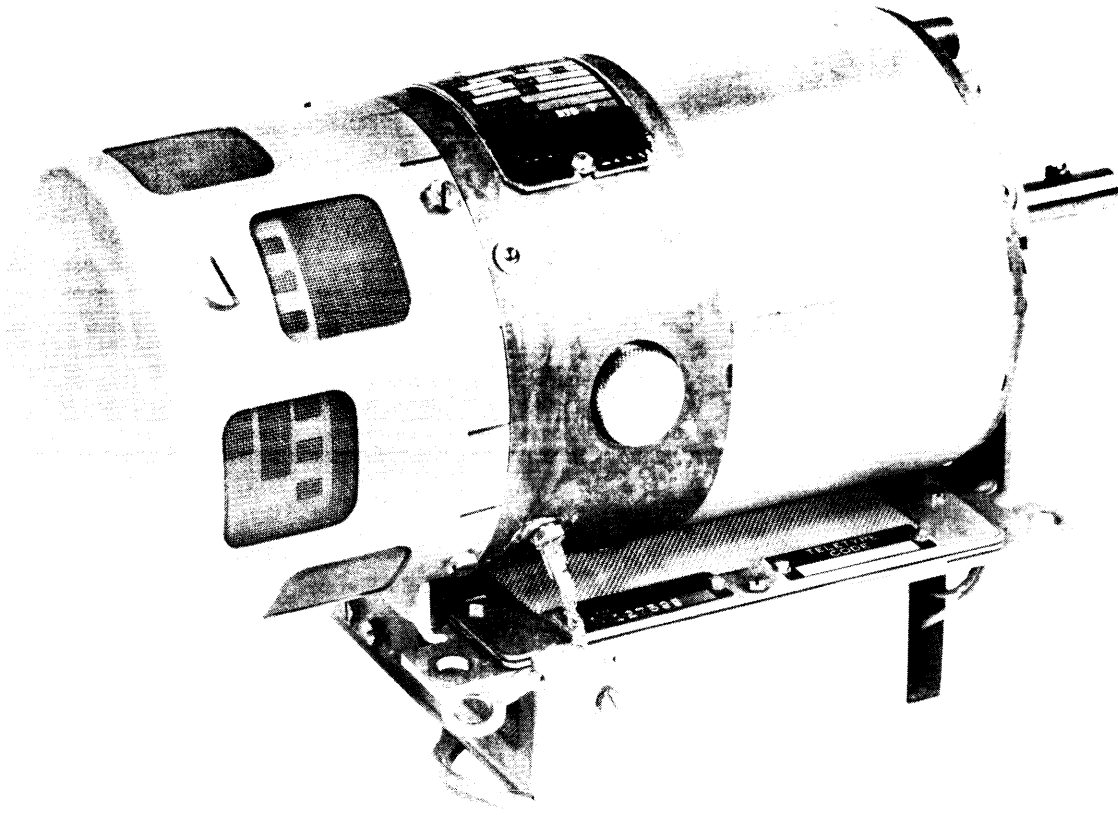
STUNT BOX FOR THE MODEL 28 TYPING UNIT

1149B

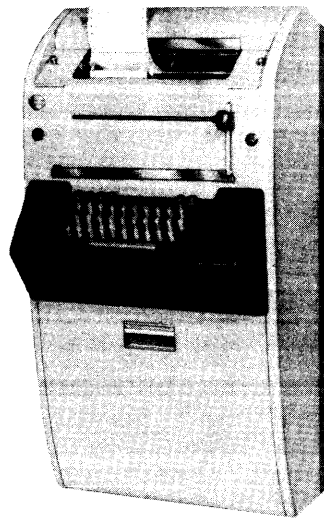


MODEL 28 SYNCHRONOUS MOTOR UNIT (LMU)

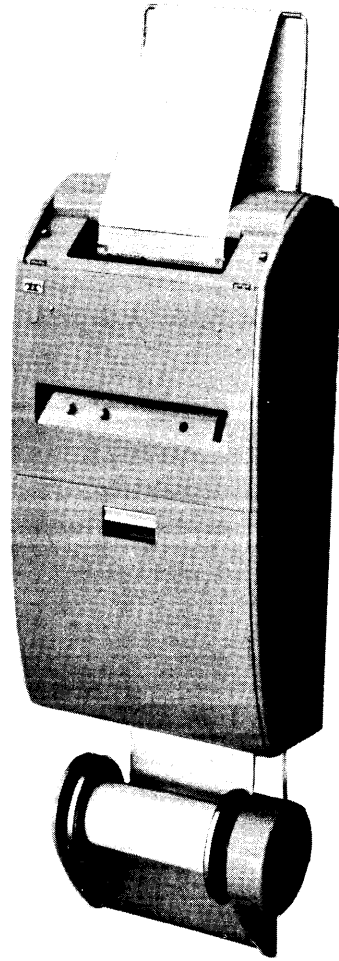
1149B



MODEL 28 GOVERNED MOTOR UNIT (LMU)



WALL MOUNTED SET  
SEND/RECEIVE (KSR)

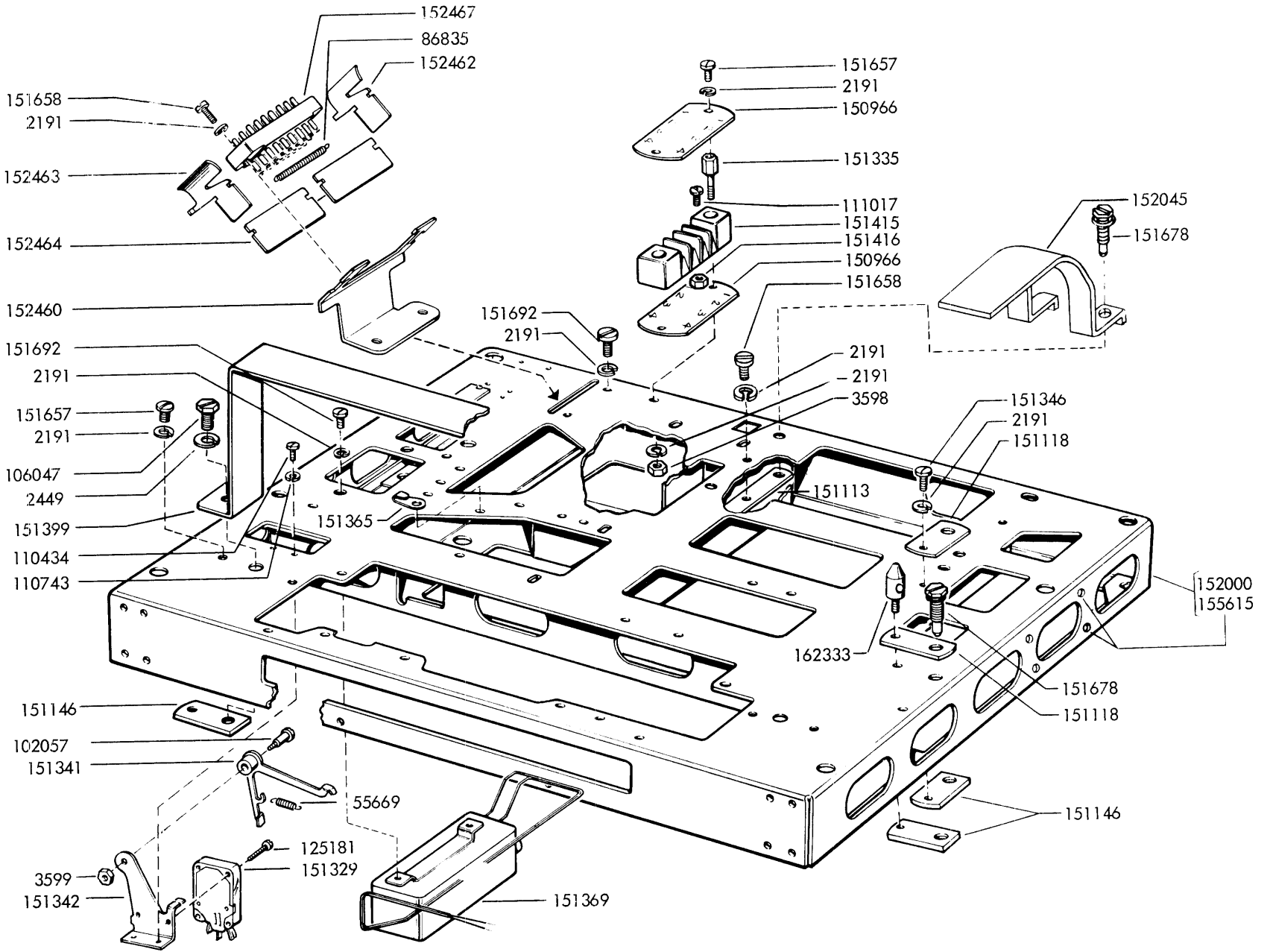


WALL MOUNTED SET  
RECEIVE ONLY (RO)

# **SECTION 1**

## **MARK II BASE AND KEYBOARD**

FIGURE 1-1. KEYBOARD OR BASE MECHANISM



11498



MARK II KEYBOARD (LK) AND BASE (LB) MAIN CABLES					
UNIT	CABLE ASSEMBLY	WIRING DIAGRAM	UNIT	CABLE ASSEMBLY	WIRING DIAGRAM
LK3	151348	2862WD	LB3	153110	2862WD
LK4	153674	2882WD	LB4,5, 8,200	153622 153803	2883WD
LK5	153621	2882WD	LB9	153622 153803	3810WD
LK7	153796	3419WD			

FOR AUXILIARY CABLES SEE FIGURE 1-26.

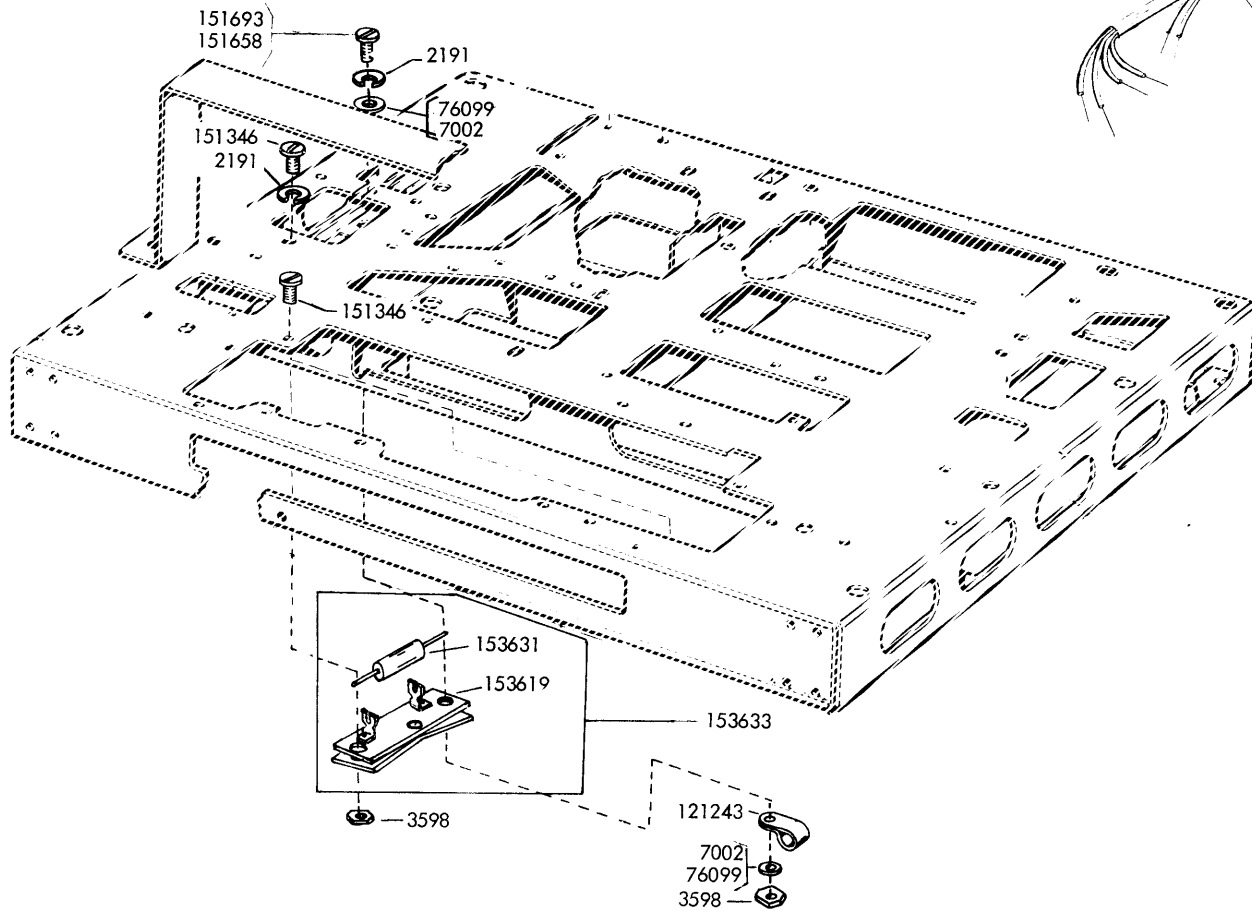
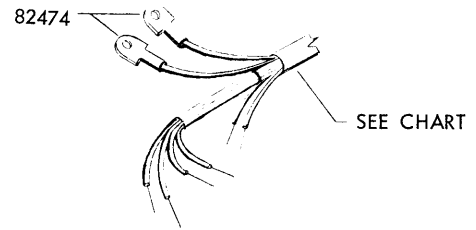
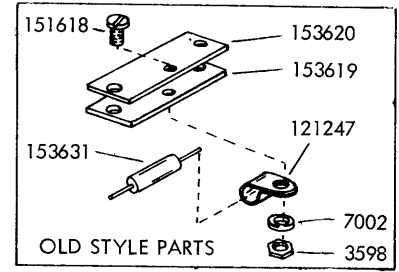


FIGURE 1-2. KEYBOARD AND BASE CABLES

1149B

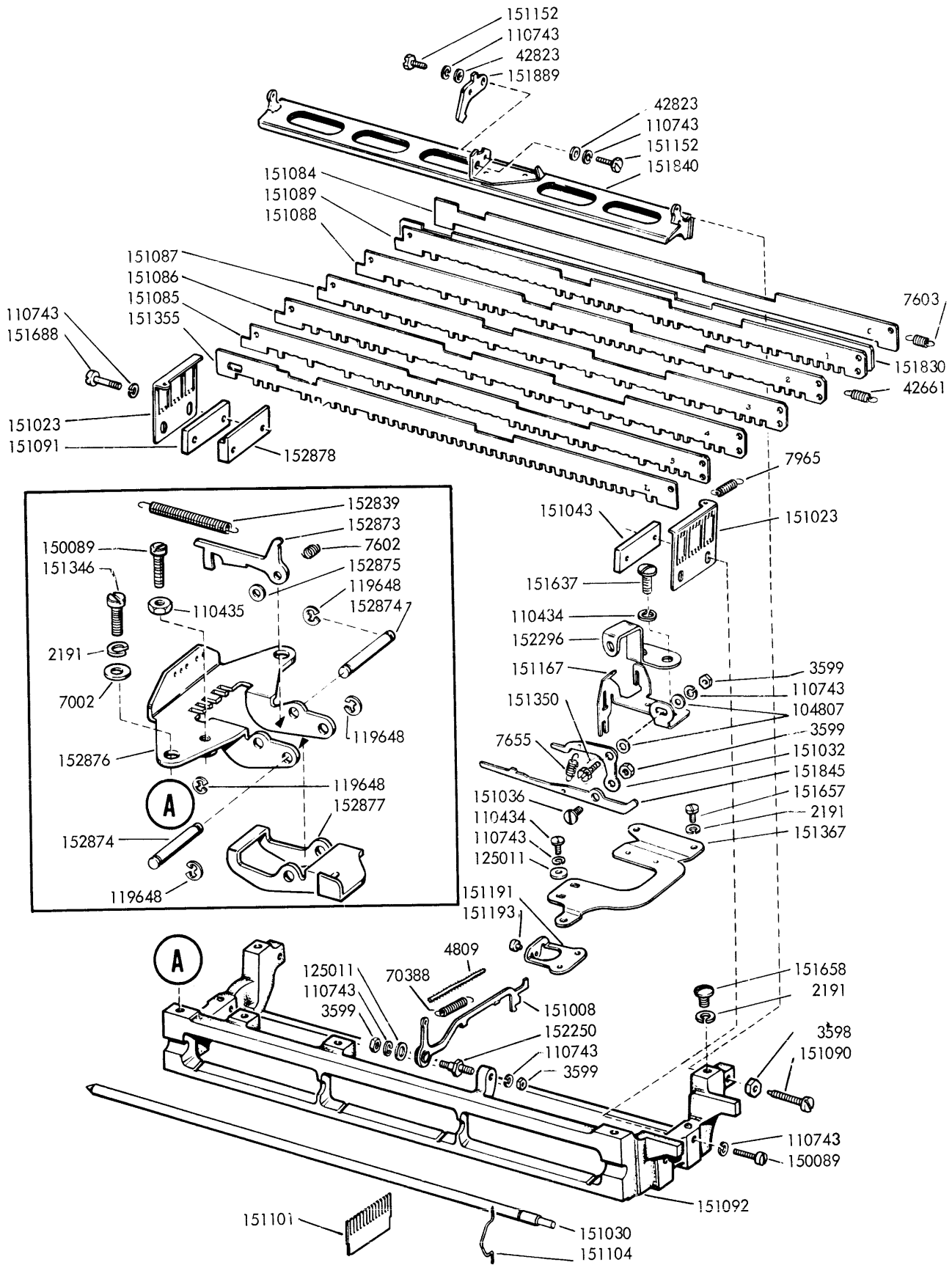
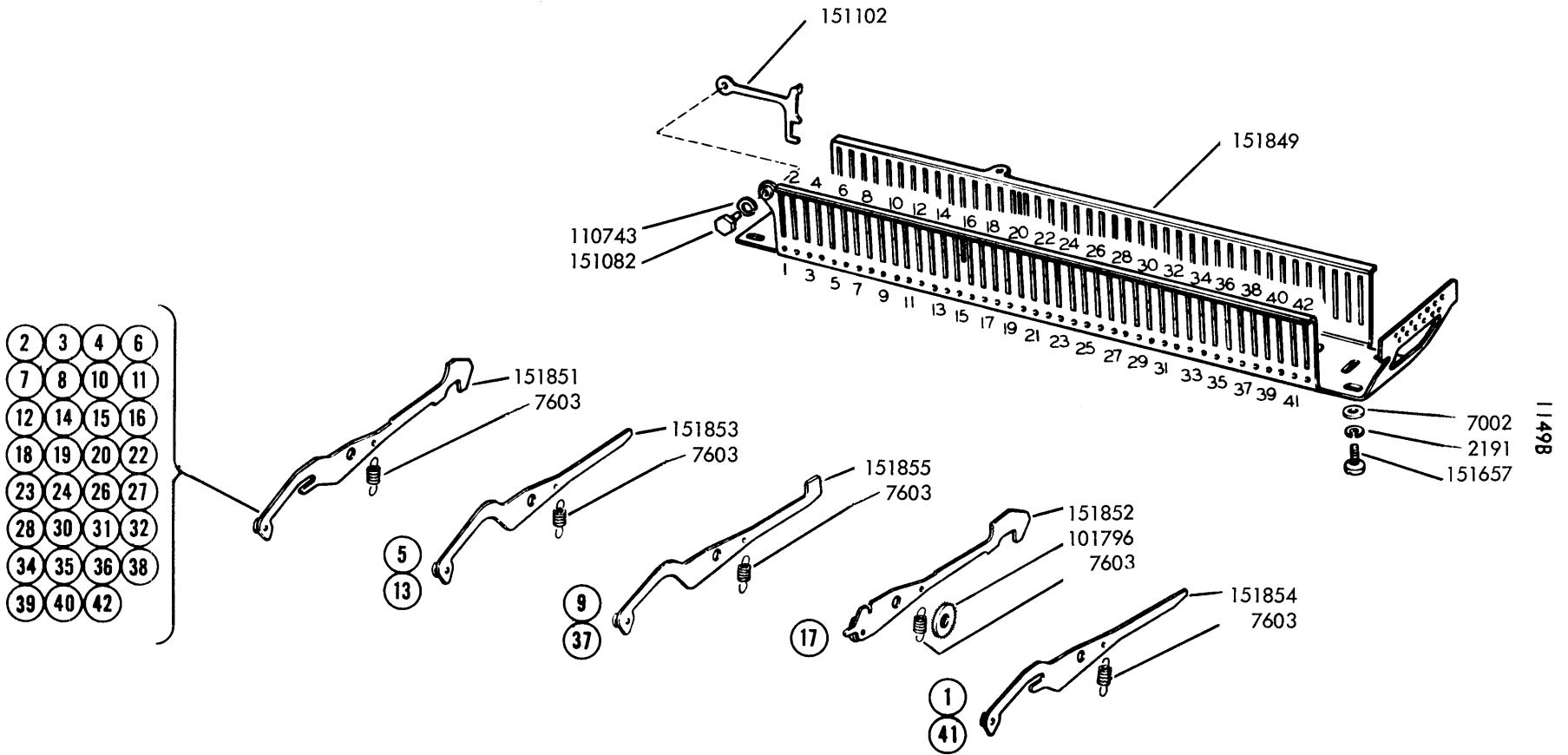


FIGURE 1-3. CODE BAR MECHANISM

FIGURE 1-4. FUNCTION AND CODE LEVERS



11498

1149B

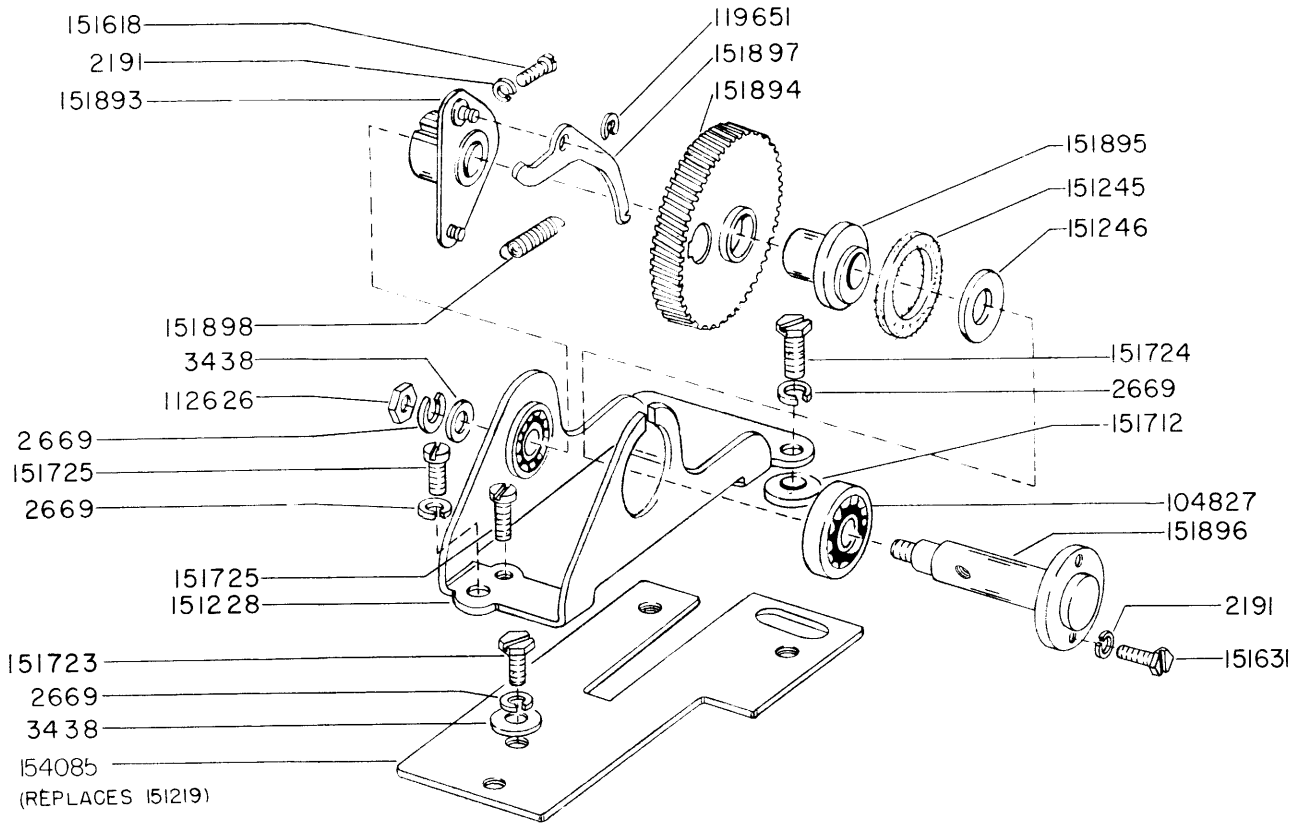


FIGURE I-5 INTERMEDIATE GEAR MECHANISM

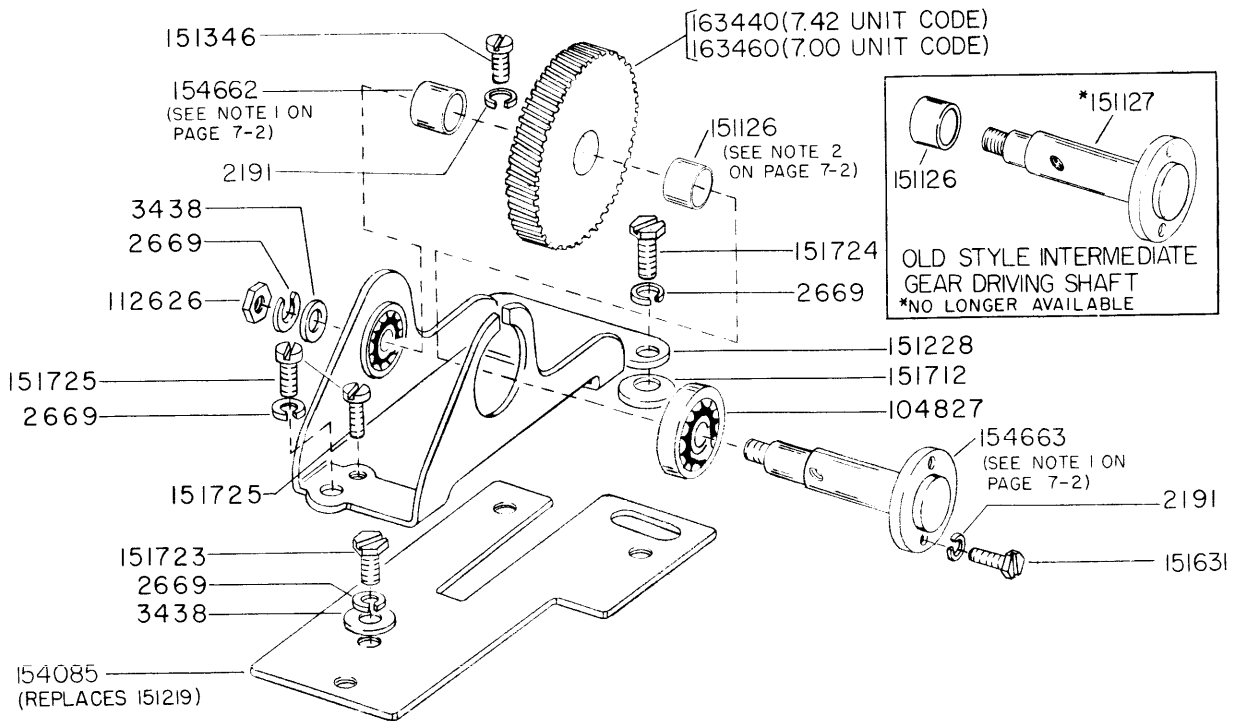


FIGURE I-6 INTERMEDIATE GEAR MECHANISM

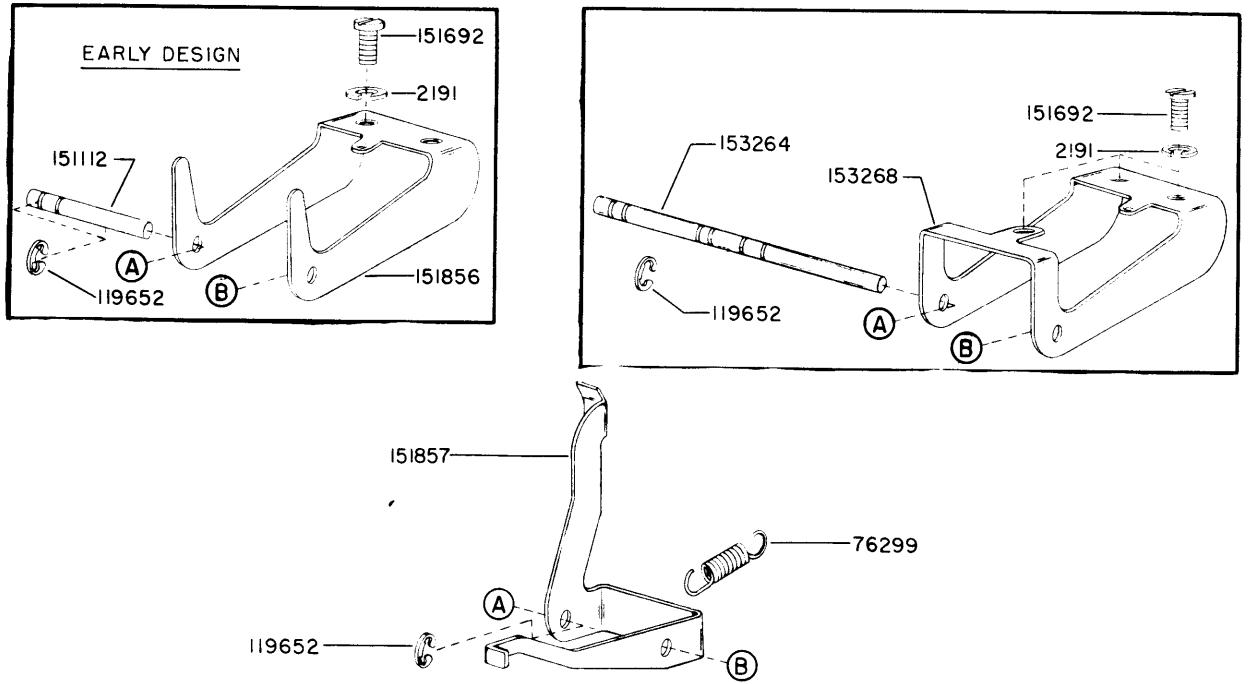


FIGURE I-7. CARRIAGE RETURN MECHANISM

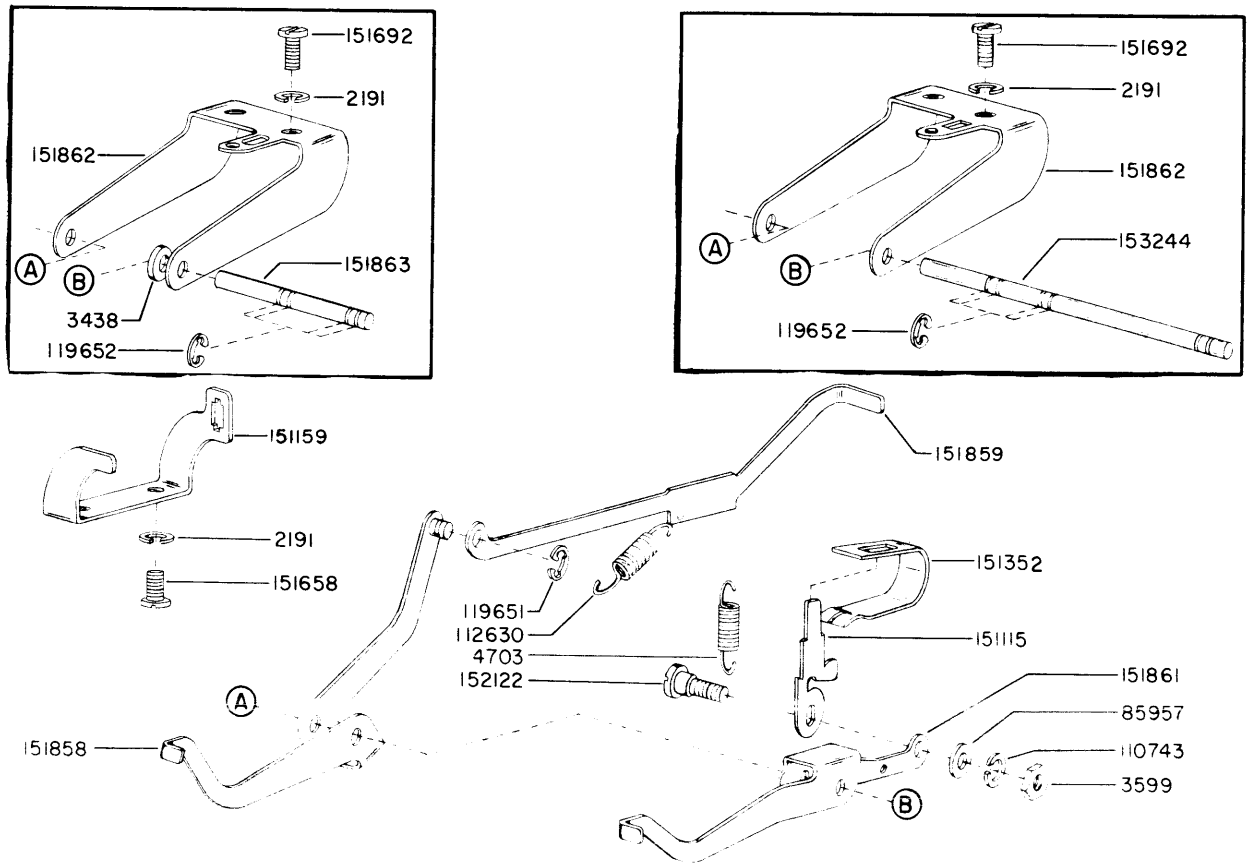
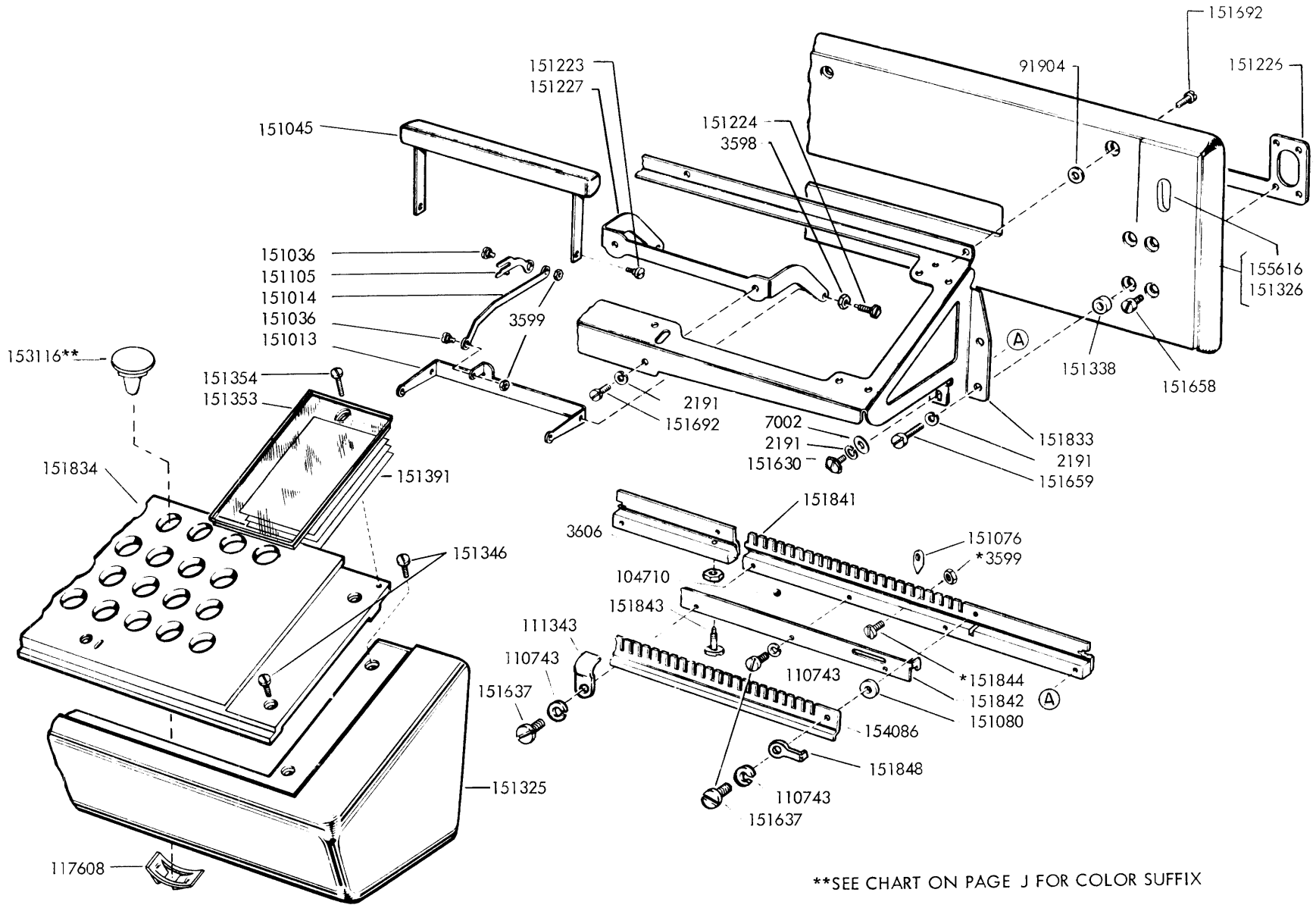


FIGURE I-8. KEYBOARD LOCK AND LOCAL LINE FEED MECHANISM

FIGURE 1-9. KEYBOARD MECHANISM



1149B

\*\*SEE CHART ON PAGE J FOR COLOR SUFFIX

\*DISCONTINUED ON LATER MODELS

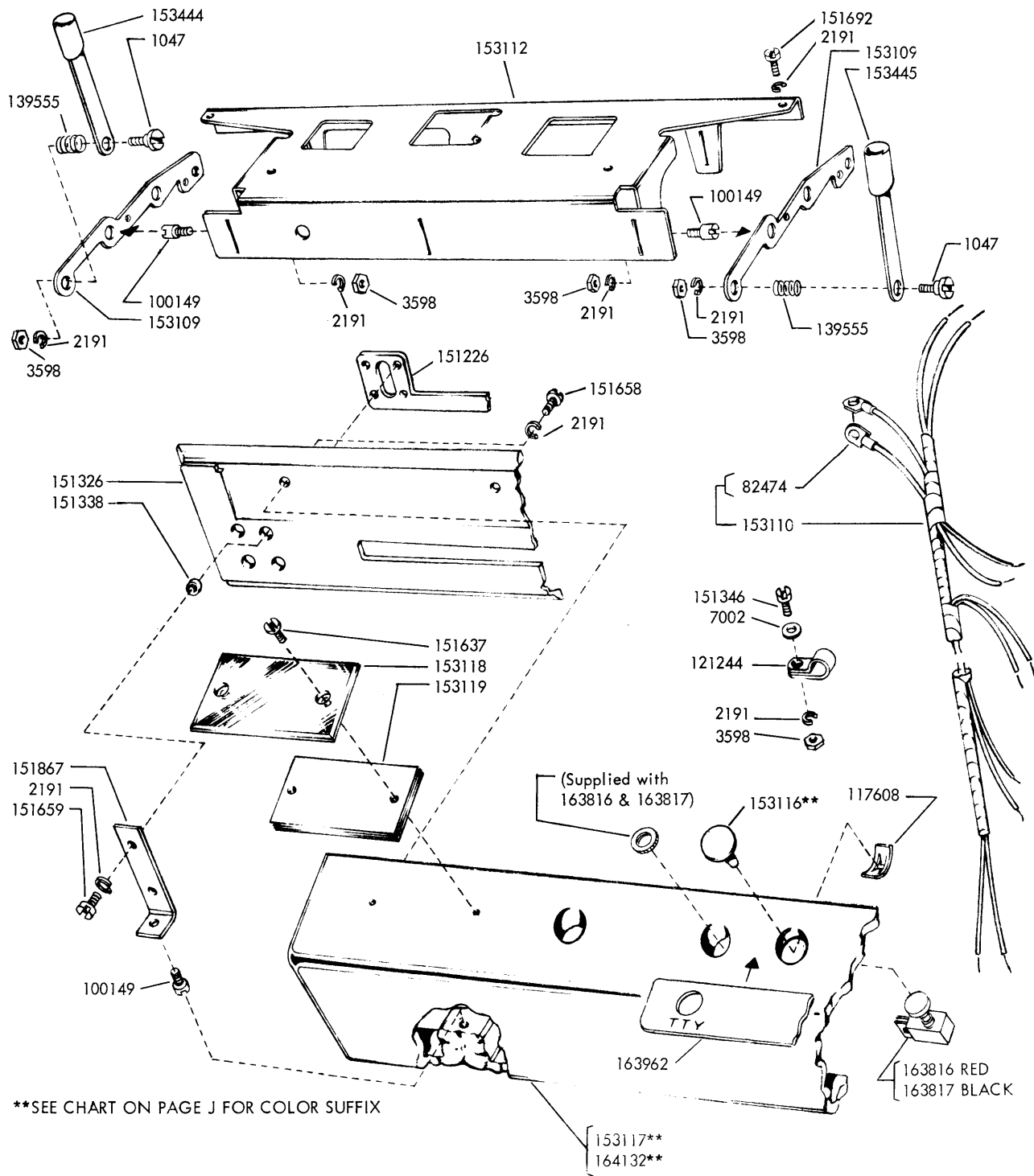


FIGURE 1-10. BASE MECHANISM

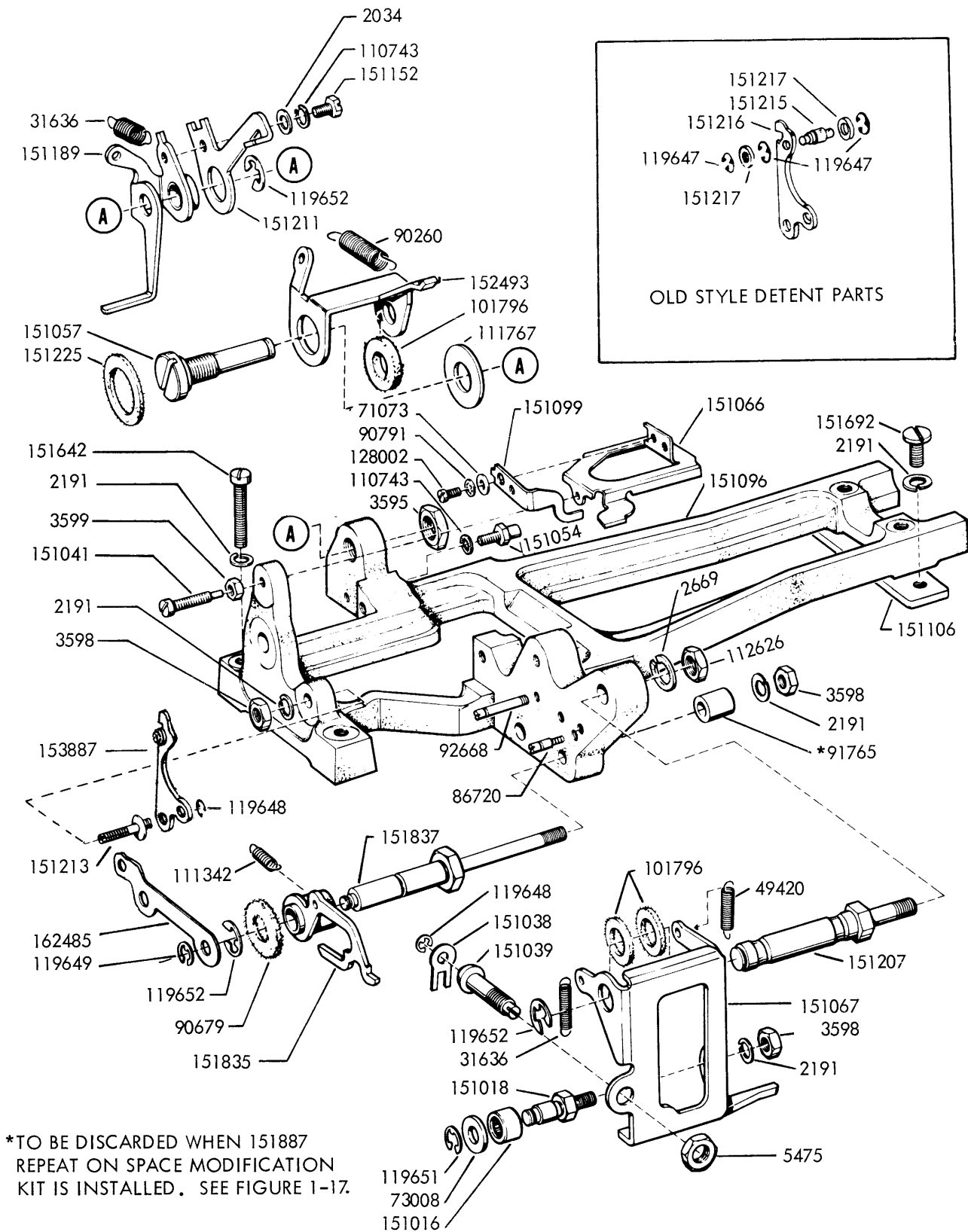
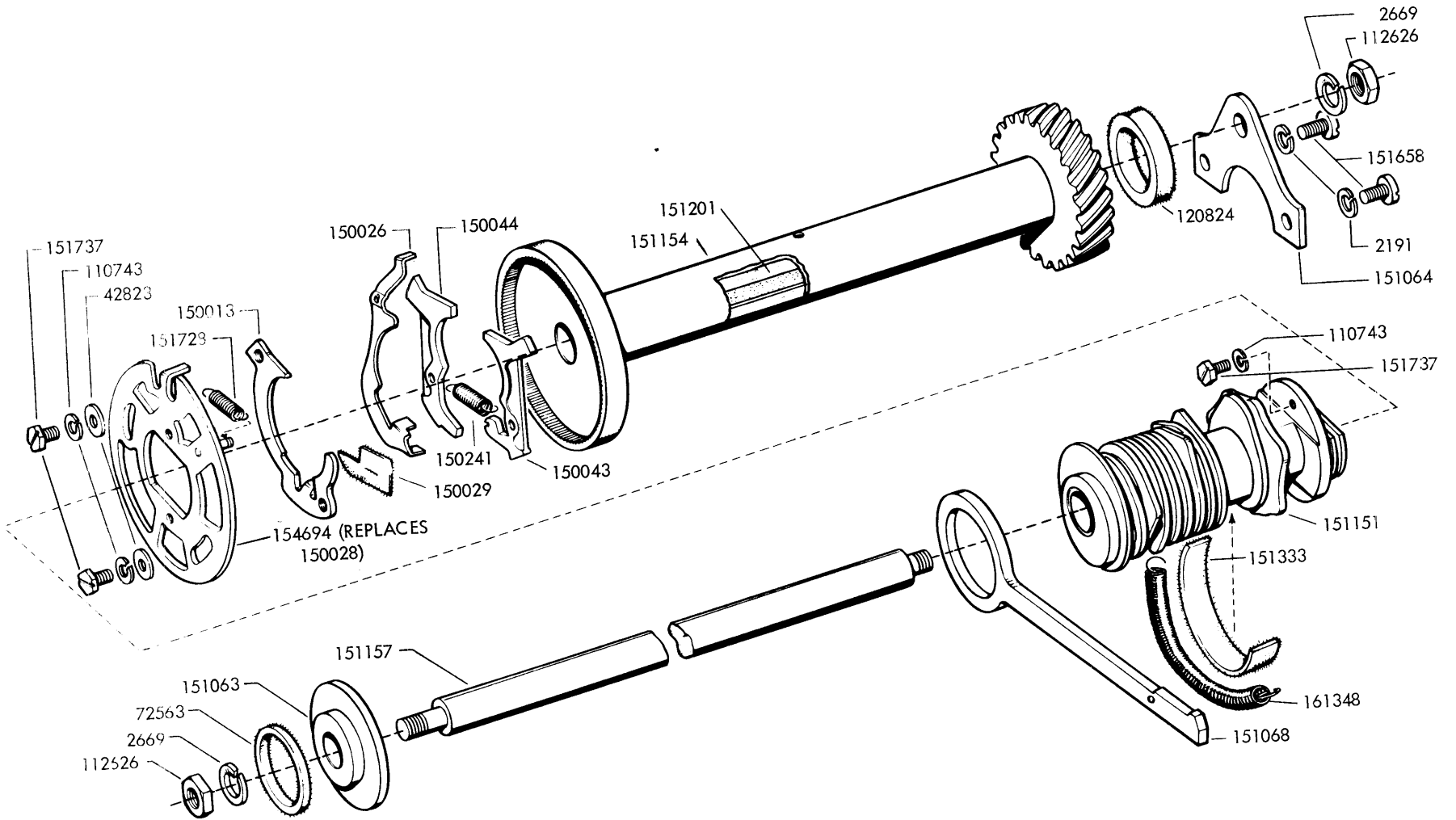


FIGURE 1-11. SIGNAL GENERATOR MECHANISM



FIGURE 1-12. SIGNAL GENERATOR MECHANISM



1149B

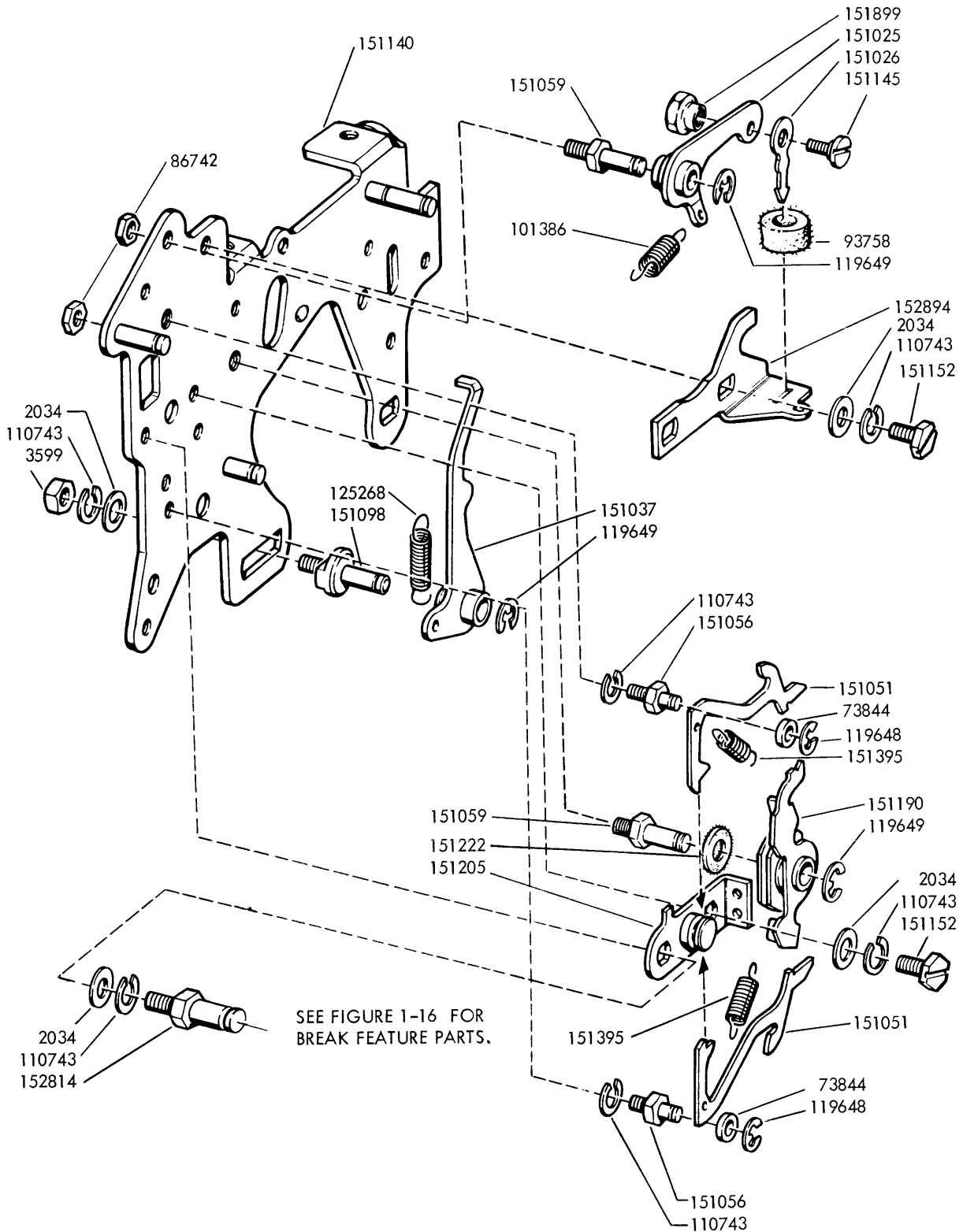


FIGURE 1-13. SIGNAL GENERATOR MECHANISM

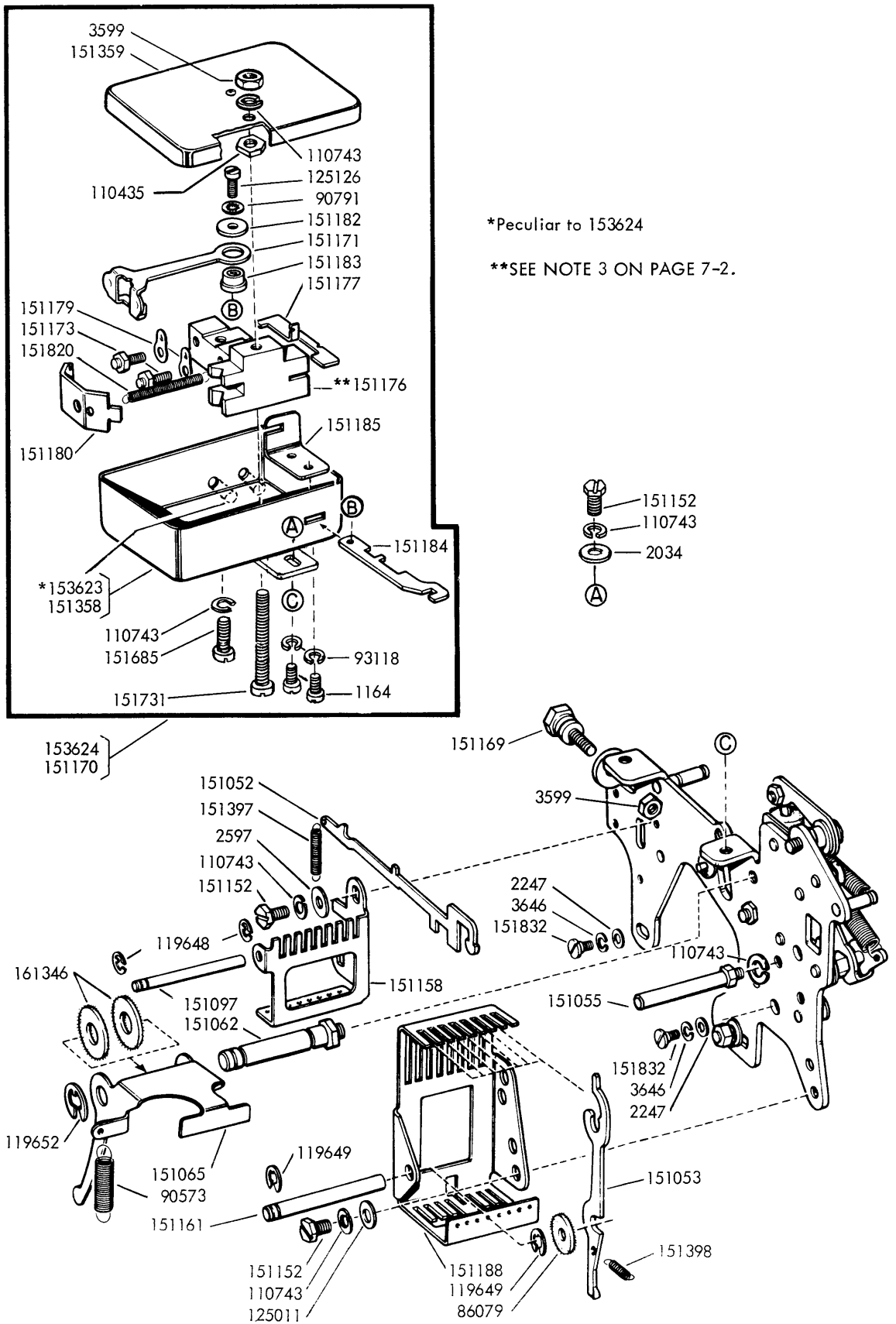
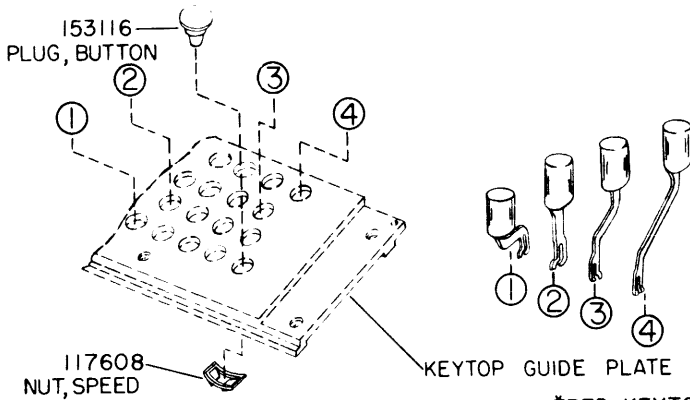
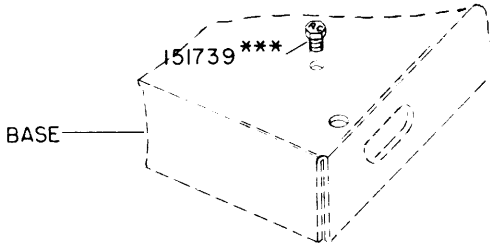


FIGURE 1-14. SIGNAL GENERATOR MECHANISM



NOTE:  
PART NUMBER OF 151739  
IDENTIFICATION SCREW TO  
INCLUDE TWO OR THREE LETTER  
SUFFIX OF KEYTOP  
ARRANGEMENT.



\*RED KEYTOPS, ALL OTHER KEYTOPS ARE GRAY-GREEN  
ALL CHARACTERS ARE WHITE

KEYTOP DESCRIPTION	PART NUMBER	KEYTOP DESCRIPTION	PART NUMBER	KEYTOP DESCRIPTION	PART NUMBER	KEYTOP DESCRIPTION	PART NUMBER	KEYTOP DESCRIPTION	PART NUMBER
E 3	151294	Q 1	151292	W 2	151293	LTRS	151320	*KBD LOCK	151289
I 8	151299	R 4	151295	X /	151314	LINE FEED	151321	*BREAK	151290
M •	151319	S BELL	151303	Y 6	151297	*LOC LF	151286	*REPT	151291
O 9	151300	T 5	151296	CAR RET	151311	*LOC CR	151287	*SEND	164434
P 0	151901	U 7	151298	FIGS	151312	*KBD UNLK	151288	*RECEIVE	164435

KEYLEVER ASSEMBLIES					KEYLEVER ASSEM. MOD. KITS				
KEYTOP DESCRIPTION	PART NUMBER	KEYTOP ARRANGEMENTS				151934 ARA TO ARC	152904 ARC TO ARD	152905 ARC TO ARB	152906 ARC TO ARA
		ARA	ARB	ARC	ARD				
A -	151302	X	X	X					
A ↑	152001				X	X			
B P	151317	X						X	
B 5/8	151909		X	X	X				
B ⊕	152002				X	X			
C 1/8	151907		X	X	X				
C ○	152003				X	X			
C :	151315	X						X	
D \$	151304	X	X	X					
D ↗	152004				X	X			
F !	151305	X						X	
F 1/4	151902		X	X	X				
F →	152005				X	X			
G &	151306	X	X	X					
G ↘	152006				X	X			
H #	152009	X	X				X	X	
H STOP	151903			X	X				
H ↓	152008				X	X			
J ▽	151308	X	X				X	X	

KEYLEVER ASSEMBLIES					KEYLEVER ASSEM. MOD. KITS				
KEYTOP DESCRIPTION	PART NUMBER	KEYTOP ARRANGEMENTS				151934 ARA TO ARC	152904 ARC TO ARD	152905 ARC TO ARB	152906 ARC TO ARA
		ARA	ARB	ARC	ARD				
J ↙	152010				X		X		
J ,	151904			X		X			
K (	151309	X						X	
K 1/2	151905		X	X		X			
K ←	152011				X		X		
L )	151310	X						X	
L 3/4	151906		X	X		X			
L ↖	152012				X		X		
N 7/8	151910		X	X		X			
N ⊕	152013				X		X		
N ,	151318	X						X	
V 3/8	151908		X	X		X			
V ⊕	152014				X		X		
V ;	151316	X						X	
Z "	151313	X	X	X					
Z +	152015				X		X		
-	151322								
-	152016				X		X		

FIGURE I-15. KEYLEVER ASSEMBLIES

## ADDITIONAL KEYLEVER ASSEMBLIES (ALSO SEE BULLETIN 1164B)

KEYTOP DESCRIPTION	PART NUMBER	KEYTOP DESCRIPTION	PART NUMBER	KEYTOP DESCRIPTION	PART NUMBER
A #	154530	F 1/3	158435	N	152138
A +	157329	G	157323	N OFF	155029
A	157365	G ON	154527	N n	157353
A ?	158418	G ↓	154532	N *	157357
A @	158438	G TAB	155037	N START	157942
B RUSH	152133	G ♂	157348	N %	157946
B OFF	152136	G TFO	157356	N &	157949
B	154525	G FO	157359	N @	157951
B %	155034	G £	157955	N +	157959
B &	157342	G :	158422	N ⊕	157970
B *	157345	G OFF	158444	N -	158412
B " "	157354	G •	158454	N )	158427
B EJT	157334	H	151307	N ∅	151301
B ↓	157944	H £	152007	P ∅	151301
B DZ	157961	H +	157358	R TAB	158450
B @	158414	H OFF	154528	S ↓	152131
B #	158417	H ∘	155026	S ∩	154535
B -	158419	H ∘ ?	157360	S ON	155030
B ¢	158434	H →	157968	S /	157328
B TAB	158443	H FO	158431	S s	157351
B ON	158452	H &	158440	S #	158439
B W-R-U	164457	J	152134	S STOP	158445
C	154523	J J	157349	S 7	157327
C #	155035	J YIP	157362	U	154524
C 1/4	157321	J ∅	152017	V %	152139
C %	157339	J ¢	152018	V =	157325
C ON	157343	J BELL	152132	V *	155033
C c	157346	J x	154533	V #	155039
C 1/2	157945	J ON	155031	V &	157336
C ¢	157957	J 1/2	157320	V ¢	157361
C &	157964	J *	157340	V x	157943
C (	158410	J %	157341	V ∇	157950
C +	158420	J YD	157958	V EA	157953
C O	158441	J Yd	157962	V ∘	157960
D ?	154531	J #	157965	V ⊕	157971
D	155038	J =	158423	V )	158411
D ∘	157322	J TAB	158447	V -	158415
D ⊕	157326	K	154521	V ,	158428
D OFF	157331	K &	157338	V ±	158442
D /	157355	K k	157350	X #	154529
D &	157956	K NYC	157363	X	157332
D ∅	157967	K STOP	157941	X FO	158430
D ;	158421	K ↓	158424	Z	152135
D BO	158448	K +	158453	Z TAB	155027
D TAB	158455	L	154522	Z ON	155028
E #	157940	L &	157947	Z OFF	155032
F	154520	L L	157966	Z %	157337
F %	152020	L .	158425	Z z	157352
F #	152130	L ?	158436	Z VERT	157344
F ¢	155025	L ATL	158449	Z FO	157948
F &	155036	L OFF	158451	Z ↓	158429
F 3/4	155040	M STOP	152019	Z *	158437
F f	157347	M #	157335	LOC RLF	153283
F CHI	157364	M %	157952	LOC B SP	153284
F ñ	157963	M	157366	. .	152137
F TAB	158406	M #	157954	- ∇	154534
F DATA	158408	M ∞	157969	BELL -	157330
F ↓	158409	M (	158426	ON .	157333
F *	158413	M M	158432	. .	158407
F F	158433	N	154526	- .	158416
				HERE IS	163852

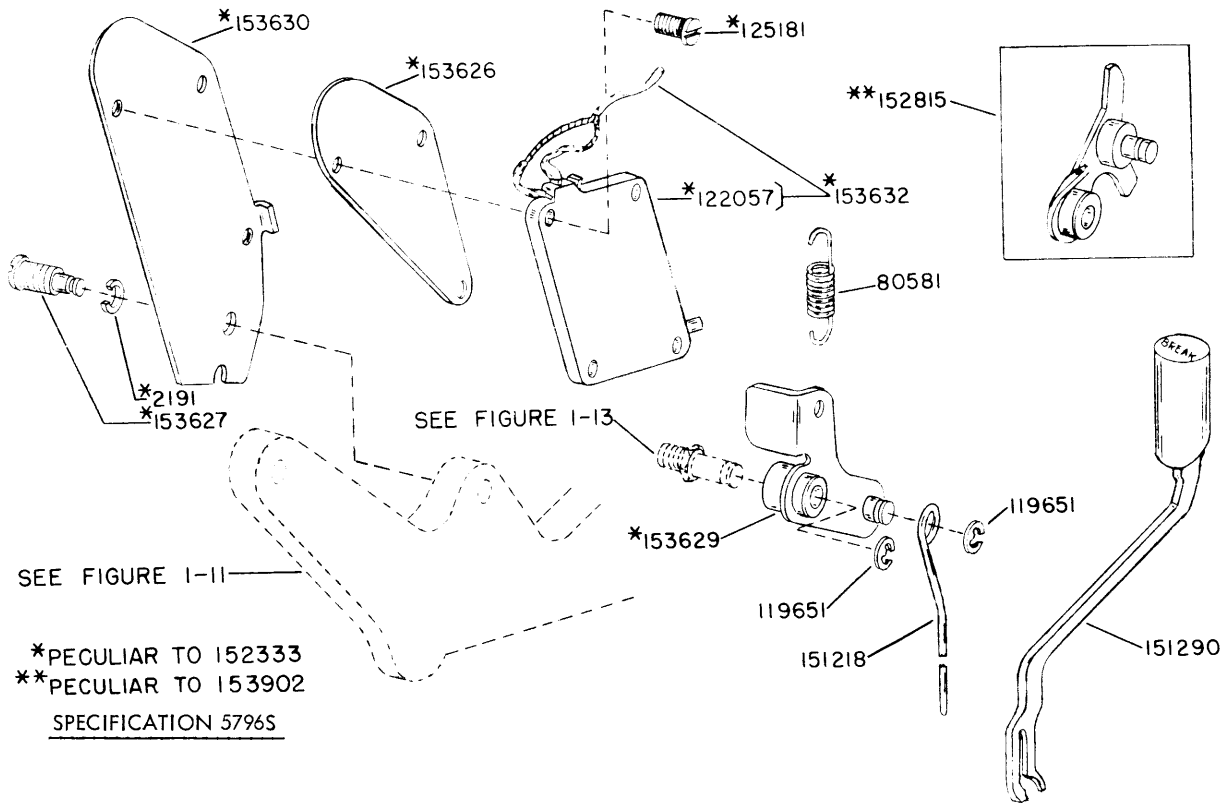


FIGURE 1-16. 152333 MODIFICATION KIT TO PROVIDE ELECTRICAL SIGNAL LINE BREAK MECHANISM (MARK II KEYBOARD)  
153902 MODIFICATION KIT TO PROVIDE MECHANICAL SIGNAL LINE BREAK MECHANISM (MARK II KEYBOARD)

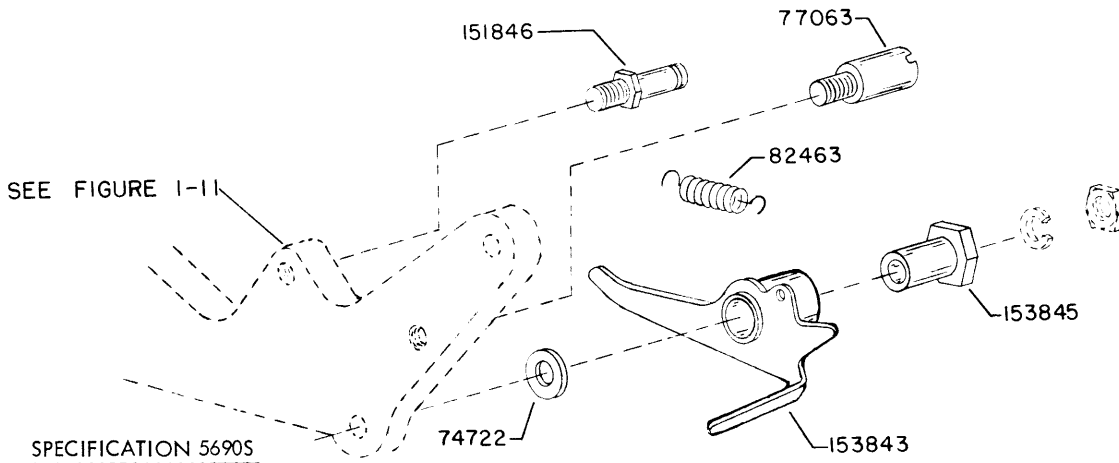
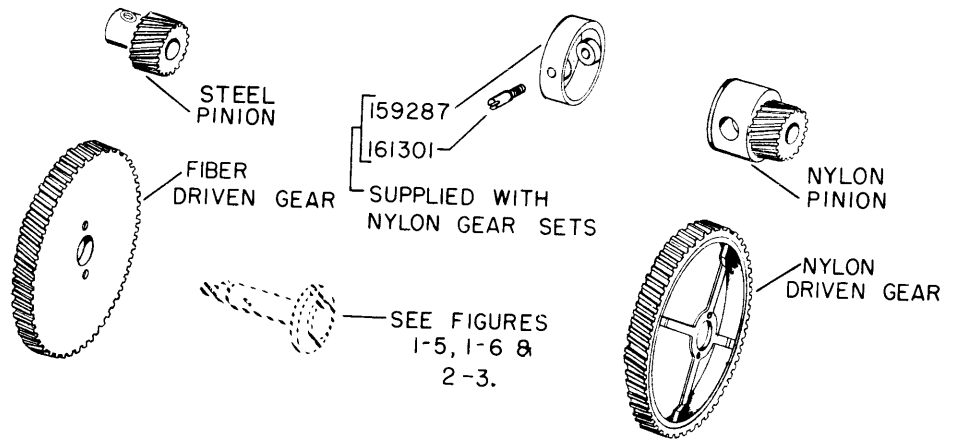


FIGURE 1-17. 151887 MODIFICATION KIT TO PROVIDE REPEAT ON SPACE MECHANISM (MARK II KEYBOARD)

1149B



GEAR SETS — 5 LEVEL CODE											
WPM	OPM	BAUD	UNIT CODE	SET NUMBER		PINION			GEAR		
				FIBER	NYLON	TEETH	STEEL	NYLON	TEETH	FIBER	NYLON
60	368	45.45	7.42	151060	161293	14	151130	159278	96	151131	159279
				*159660	—	10	*159661	—	57	*159662	—
				**161111	—	14	**161106	—	96	151131	—
67	404	50	7.42	152766	—	13	152765	—	81	152764	—
				*159667	—	15	*159663	—	78	*159664	—
71	428	50	7.00	—	163504	18	—	163461	117	—	163462
75	460	56.88	7.42	151075	161294	17	151132	159281	93	151133	159282
				*159675	—	14	*159665	—	64	*159666	—
100	600	74.2	7.42	151100	161295	20	151134	159284	84	151135	159285
				*159700	—	20	*159668	—	70	*159669	—
				—	—	20	**153993	—	84	151135	—
107	643	75	7.00	—	163505	24	—	163463	104	—	163464

\* GEAR SETS, PINIONS AND GEARS MARKED WITH AN ASTERISK (\*) ARE USED WITH SYNCHRONOUS MOTORS OPERATING AT 3000 RPM ON 50 CYCLES.  
 \*\* SPECIAL GEARS FOR LMU10.

FIGURE I-18. GEAR SETS

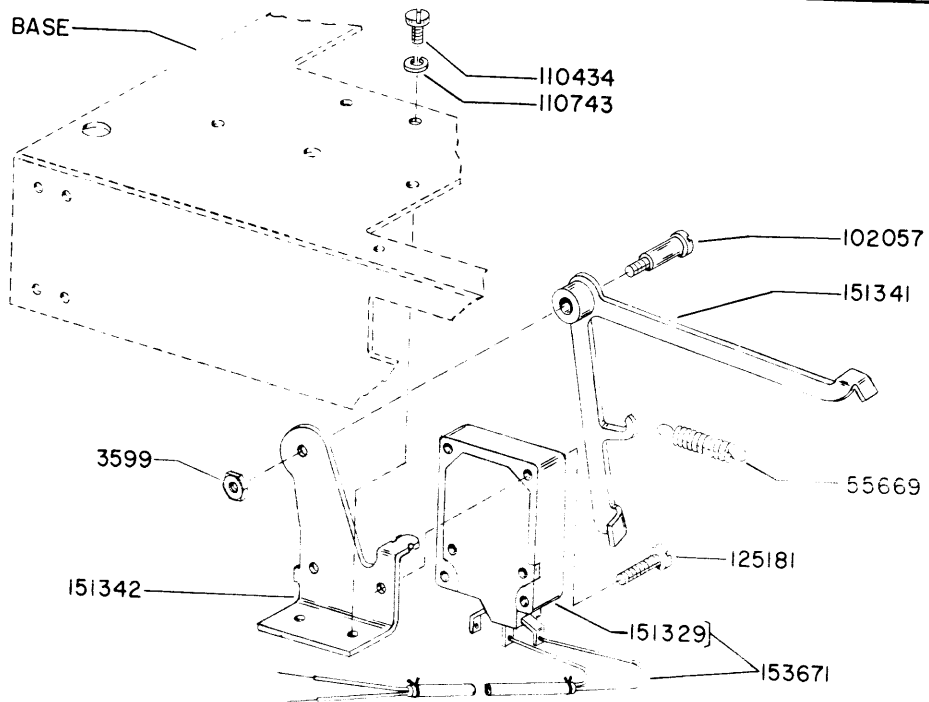
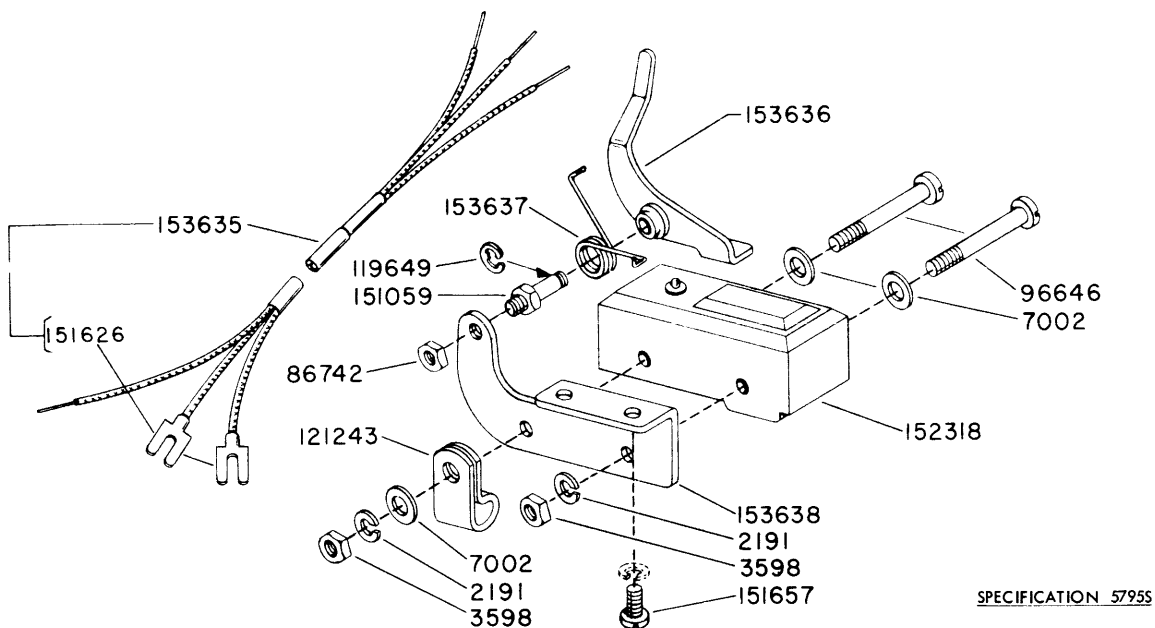
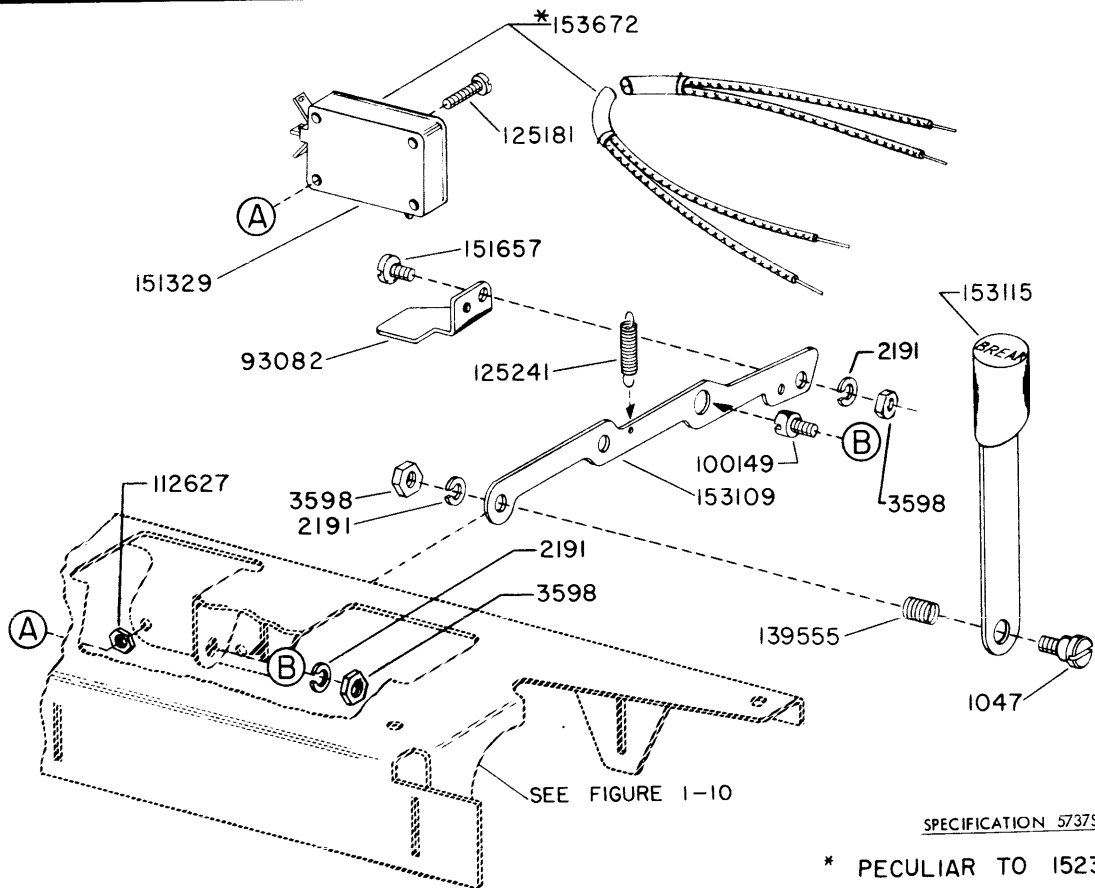


FIGURE I-19. 152343 MODIFICATION KIT TO PROVIDE END-OF-LINE SWITCH MECHANISM



SPECIFICATION 57955

FIGURE I-20. 152334 MODIFICATION KIT TO PROVIDE PAPER FEED-OUT MOTOR STARTING MECHANISM (MARK II KEYBOARD OR BASE)

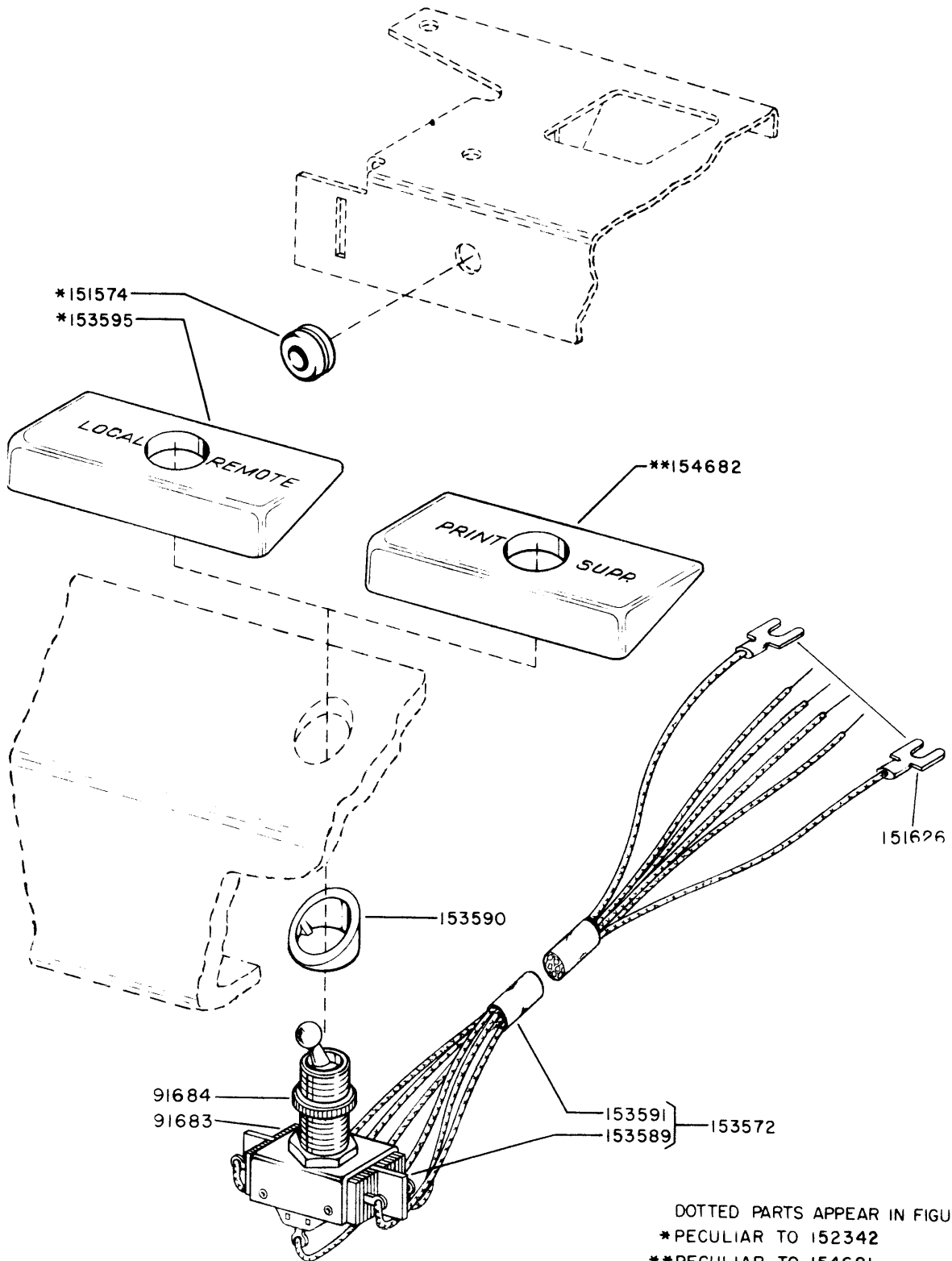


SPECIFICATION 57375

\* PECULIAR TO 152344

FIGURE I-21. 152911 MODIFICATION KIT TO PROVIDE SIGNAL LINE BREAKING MECHANISM-LESS SWITCH (MARK II BASE)  
 152344 MODIFICATION KIT TO PROVIDE SIGNAL LINE BREAKING MECHANISM (MARK II BASE)





DOTTED PARTS APPEAR IN FIGURE I-10  
 \*PECULIAR TO 152342  
 \*\*PECULIAR TO 154681

FIGURE I-22. 152342 MODIFICATION KIT TO PROVIDE LOCAL-REMOTE SWITCH (MARK II BASE)

154681 MODIFICATION KIT TO PROVIDE PRINT SUPPRESSION SWITCH (MARK II BASE)

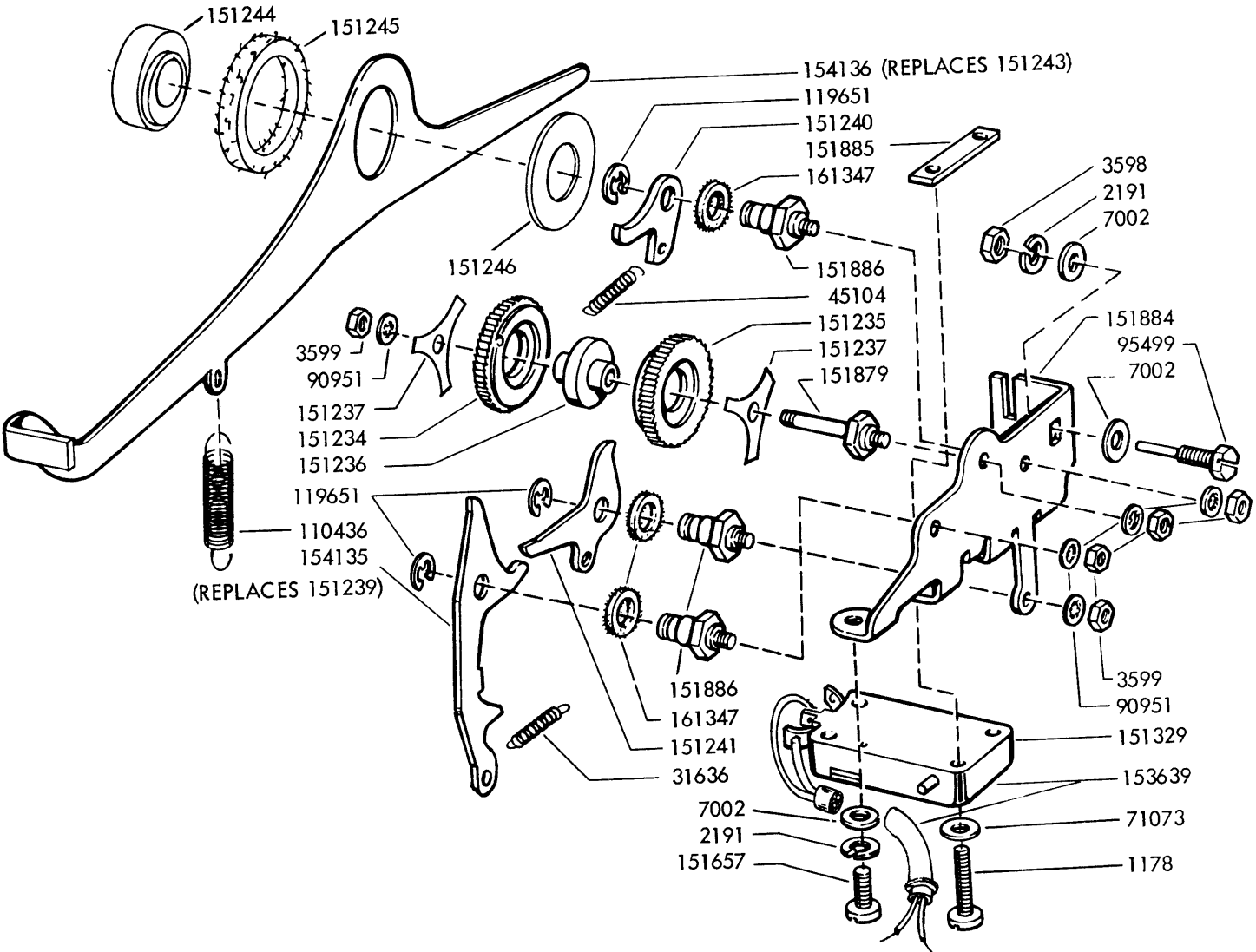
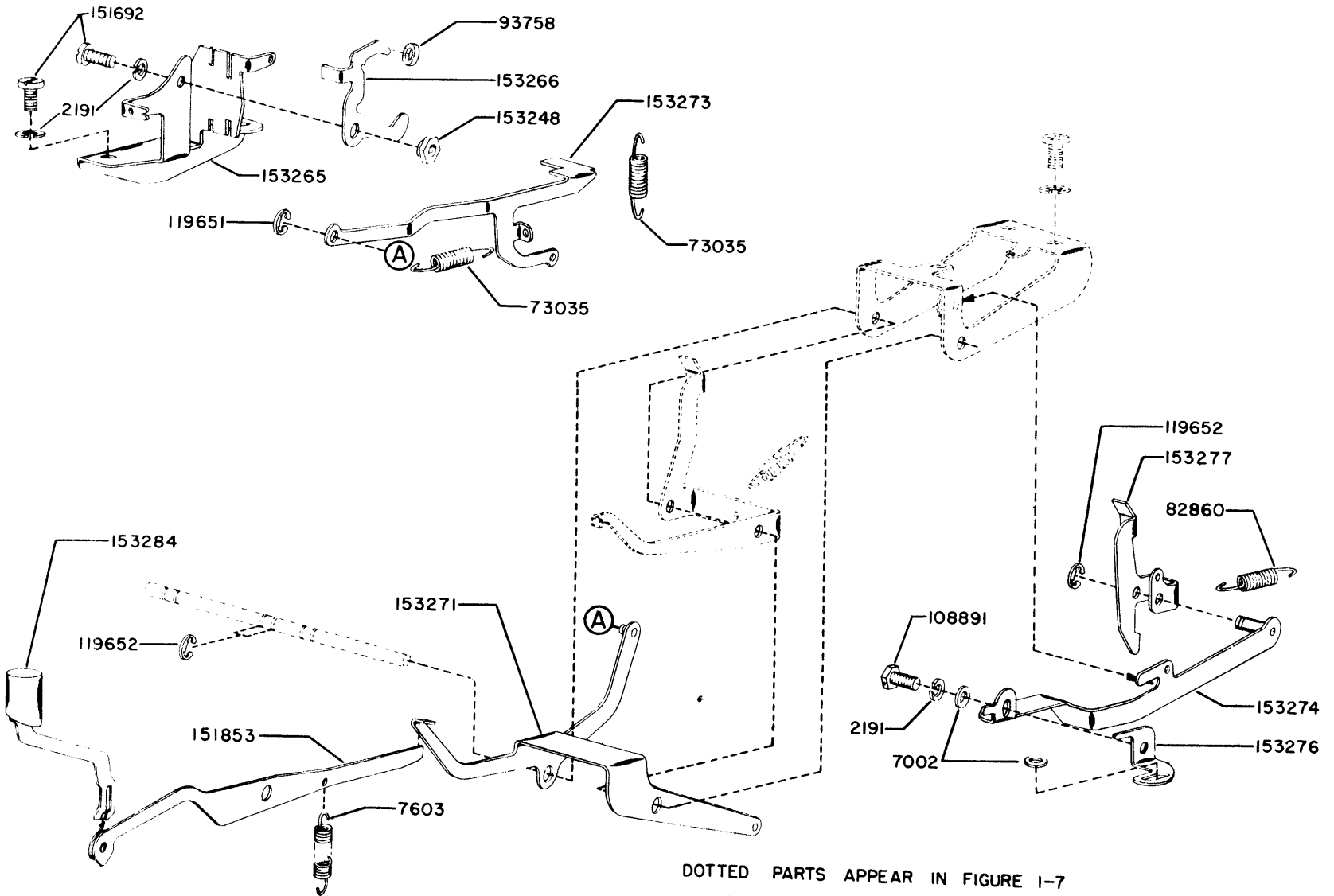


FIGURE 1-23. 152338 MODIFICATION KIT TO PROVIDE TIME DELAY MECHANISM  
(MARK II KEYBOARD OR BASE)

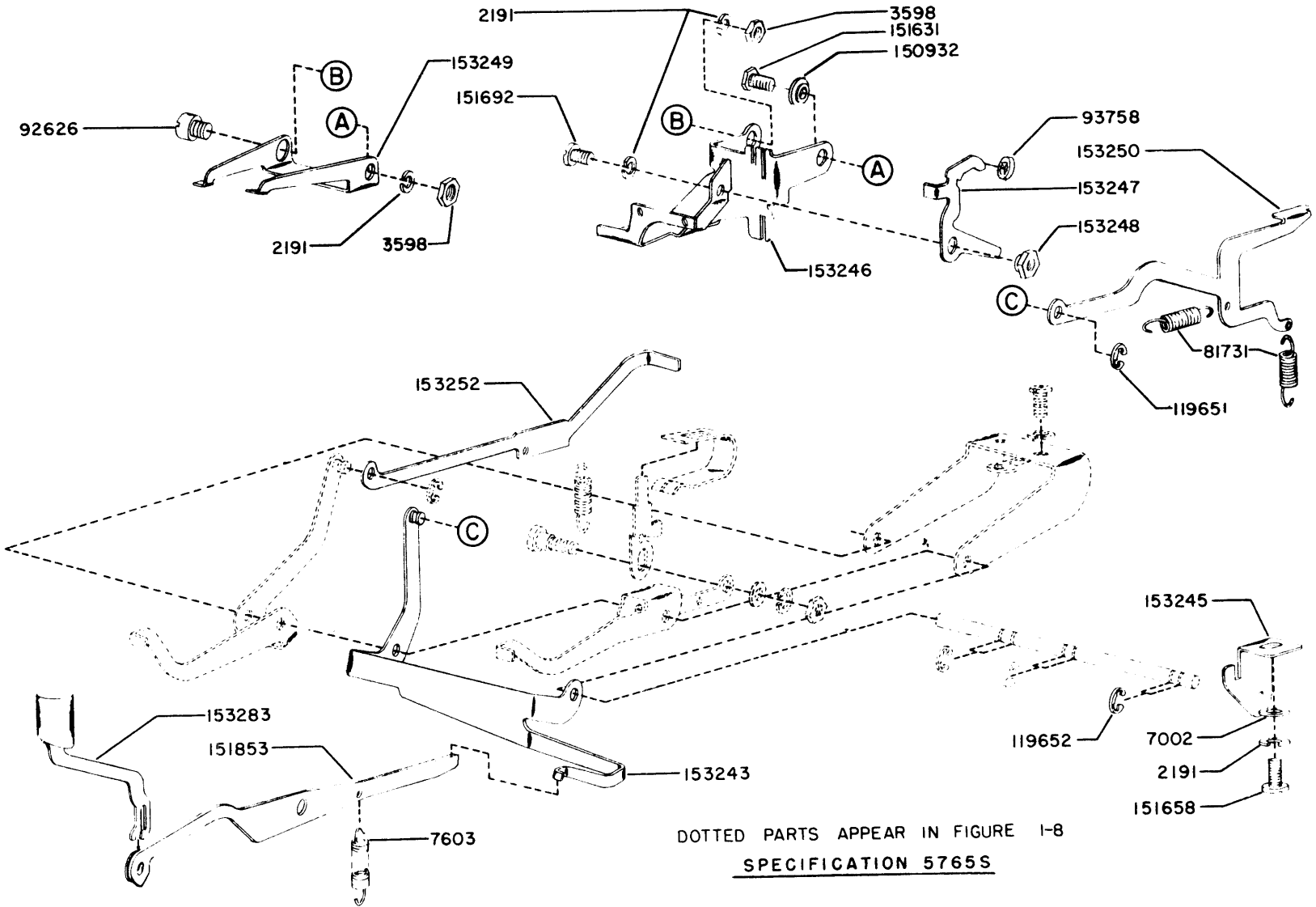
SPECIFICATION 5661S

FIGURE 1-24. 152918 MODIFICATION KIT TO PROVIDE LOCAL BACK SPACE MECHANISM (MARK II KEYBOARD)



DOTTED PARTS APPEAR IN FIGURE 1-7  
SPECIFICATION 5765 S

FIGURE 1-25. 152916 MODIFICATION KIT TO PROVIDE LOCAL REVERSE LINE FEED MECHANISM (MARK II KEYBOARD)



DOTTED PARTS APPEAR IN FIGURE 1-8  
SPECIFICATION 5765S

11498

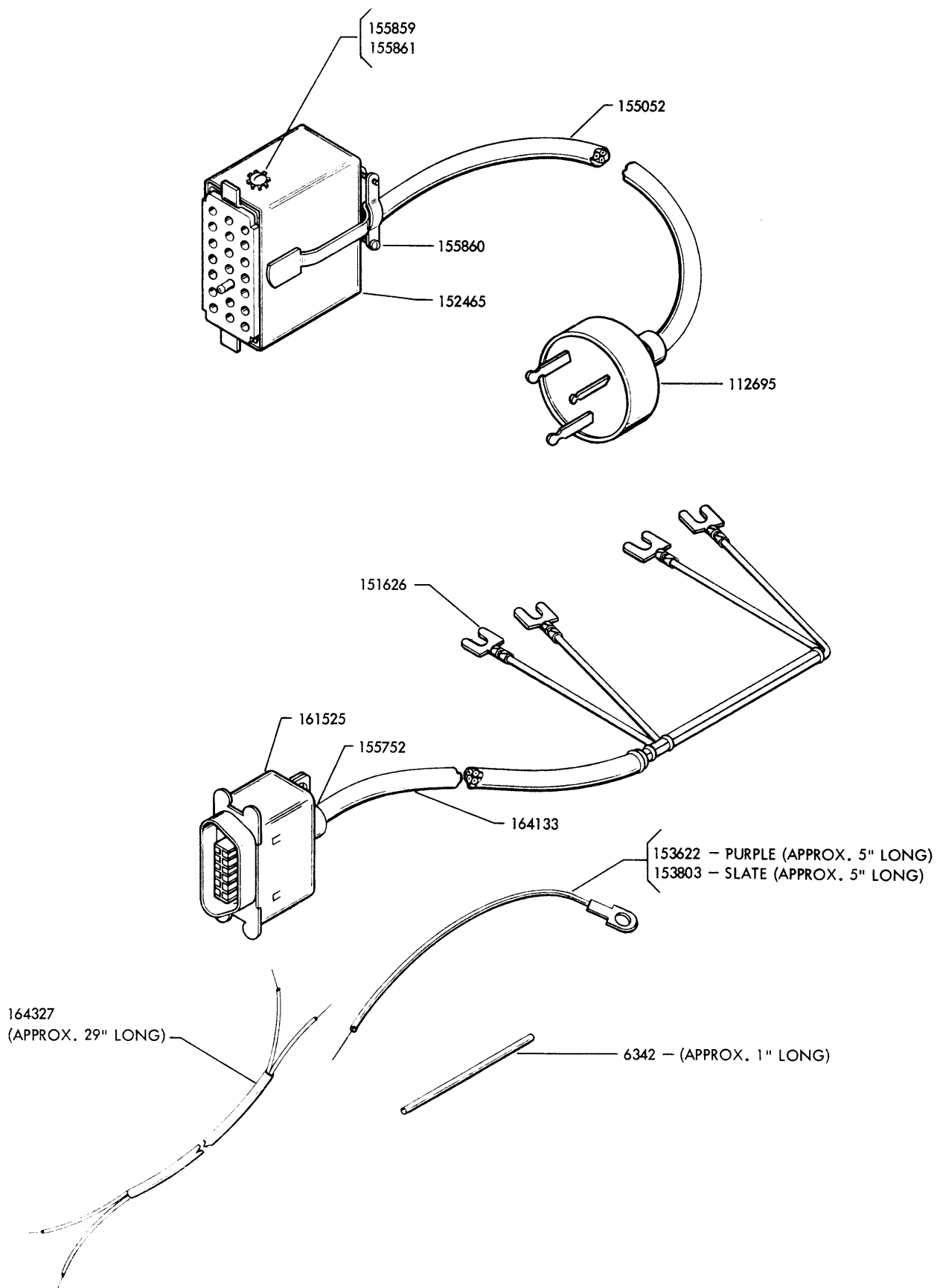
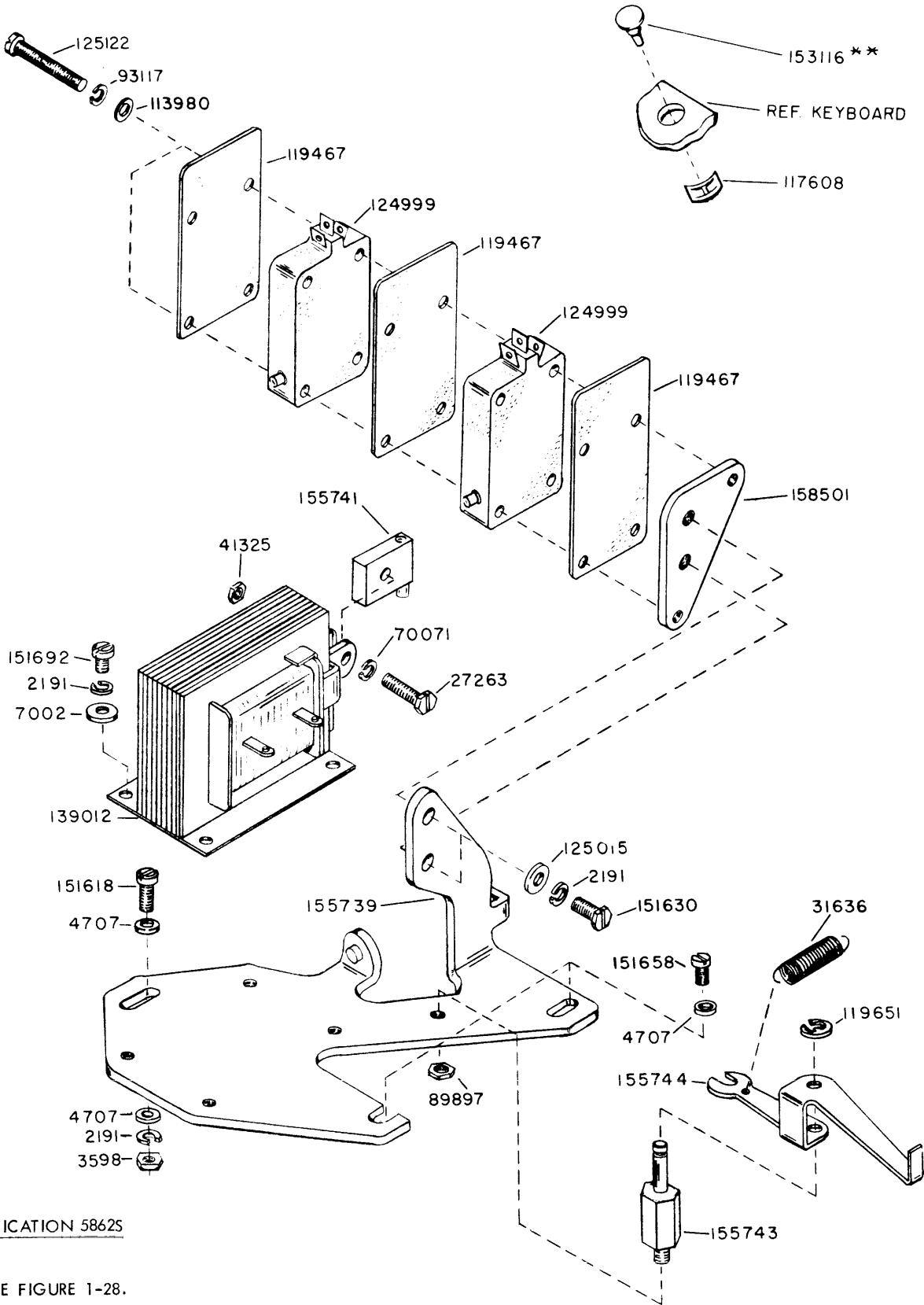


FIGURE 1-26. AUXILIARY CABLES (MARK II KEYBOARD OR BASE)

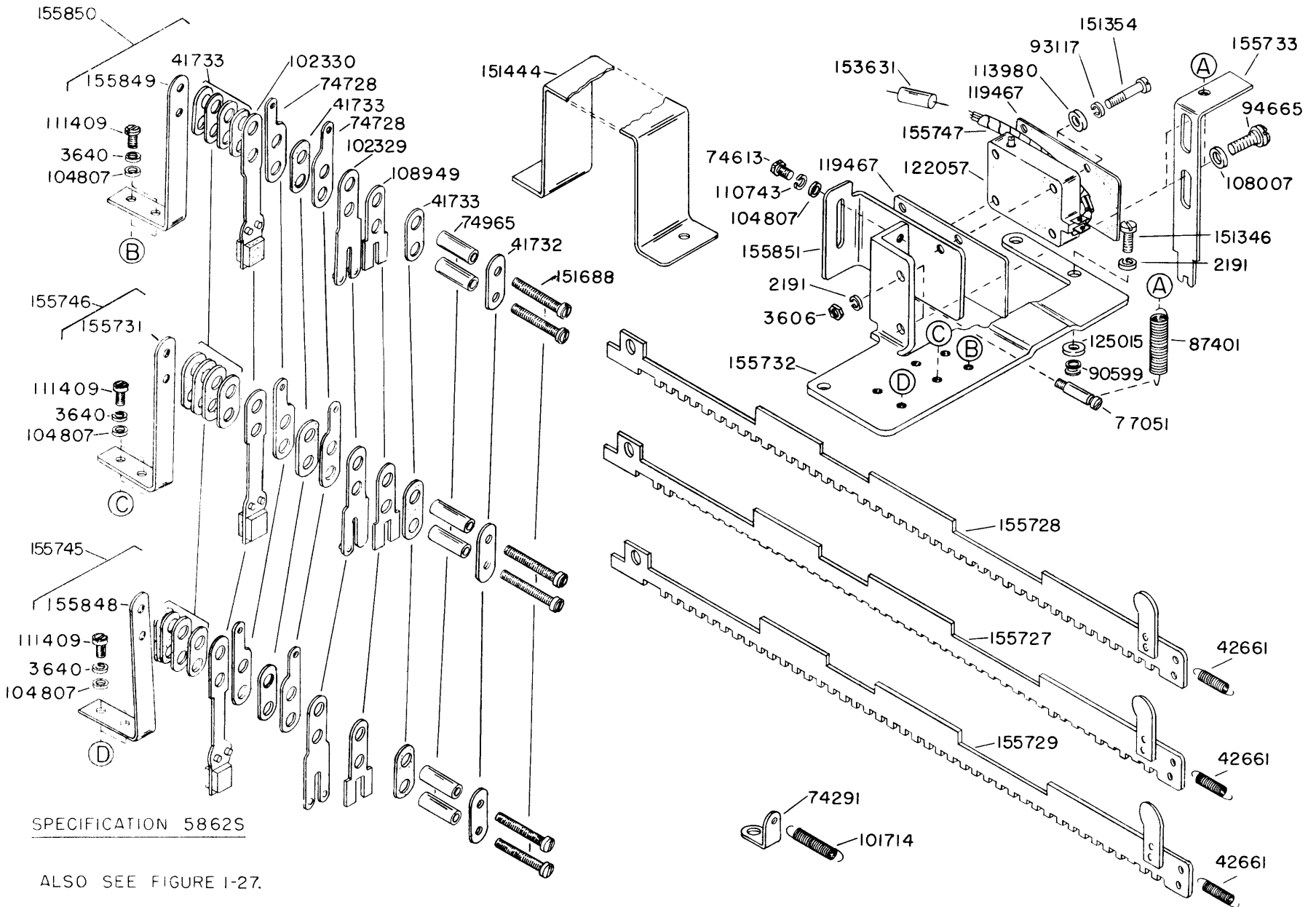


SPECIFICATION 58625

ALSO SEE FIGURE 1-28.

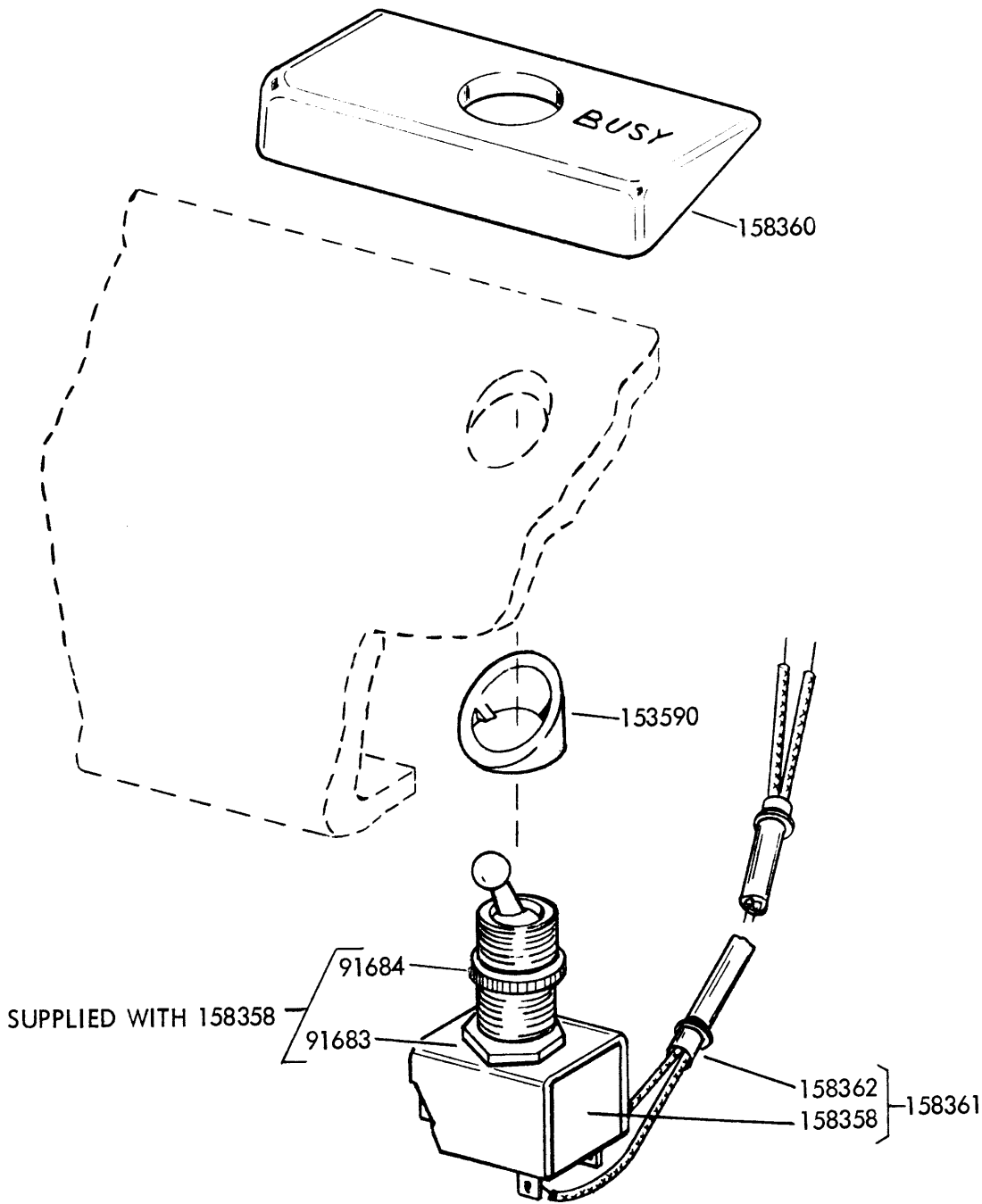
FIGURE 1-27 154783 MODIFICATION KIT TO EQUIP A KEYBOARD WITH "OFF-LINE" CONTACTS

FIGURE I-28 154783 MODIFICATION KIT TO EQUIP A KEYBOARD WITH "OFF-LINE" CONTACTS



SPECIFICATION 5862S

ALSO SEE FIGURE I-27.



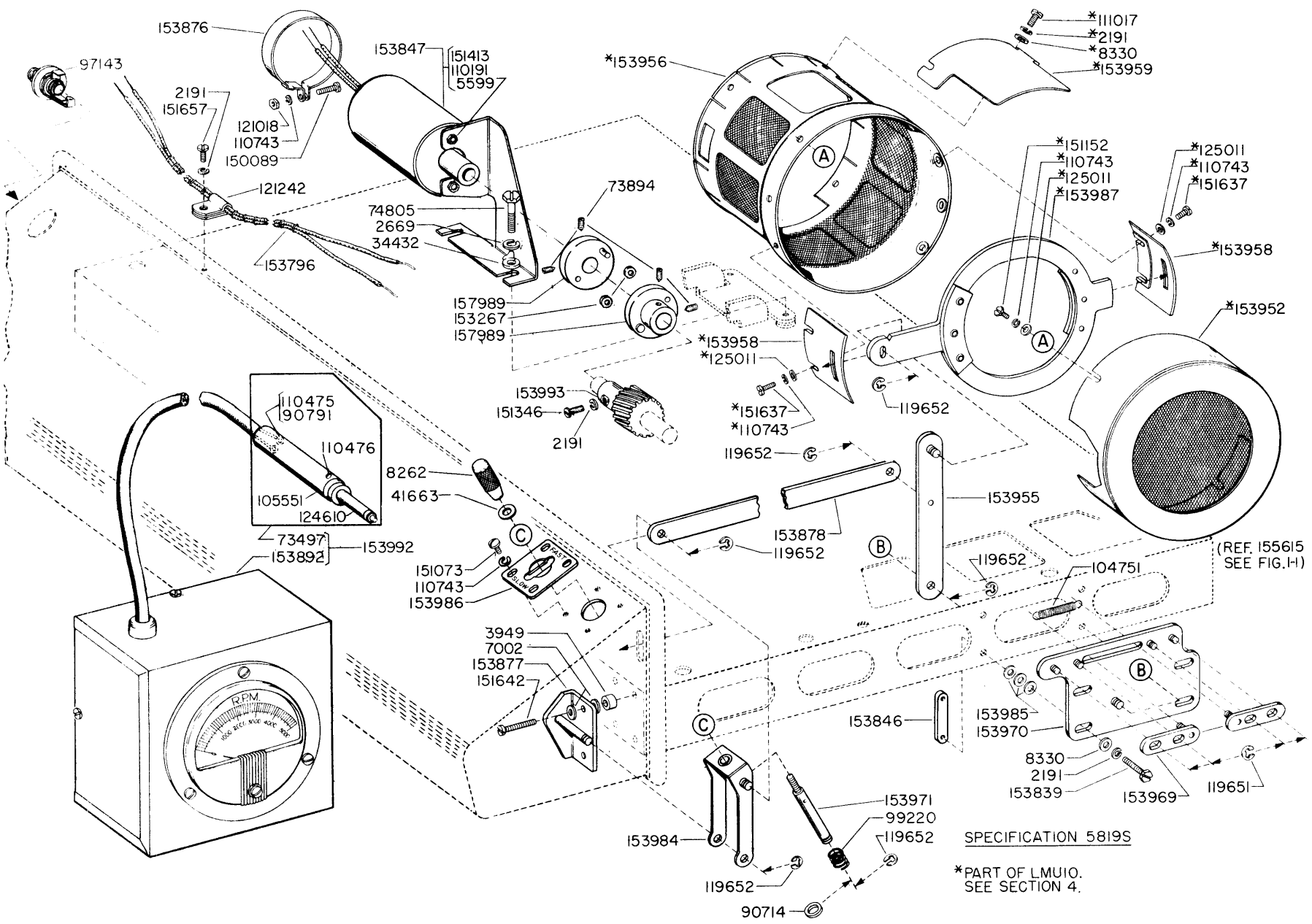
SPECIFICATION 5772S

FIGURE 1-29. 158359 MODIFCATION KIT TO PROVIDE BUSY KEY SWITCH  
(MARK II BASE)



CHANGE 9

FIGURE 1-30. TACHOMETER AND GOVERNOR ADJUSTMENT LINKAGE



11498

## NUMERICAL INDEX - SECTION I

Part Number	Description and Page Number	Part Number	Description and Page Number	Part Number	Description and Page Number
1047	Screw, Shoulder (6-40) 1-9, 1-18	74805	Screw (10-32 x 3/4 Hex) 1-27	108007	Space 1-25
1164	Screw (6-40 x 3/16 Fil) 1-13	74965	Bushing 1-25	108891	Screw (6-40 x 3/16 Hex) 1-21
1178	Screw (2-56 x 7/16 Fil) 1-20	76099	Washer, Flat 1-3	108949	Stiffener 1-25
2034	Washer, Flat 1-10, 1-12, 1-13	76299	Spring 1-7	110191	Washer, Lock 1-27
2191	Washer, Lock (Sev.)	77051	Post, Spring 1-25	110434	Screw (4-40 x 3/16 Hex) 1-2, 1-4, 1-17
2247	Washer, Flat 1-13	77063	Screw, Stop (4-40) 1-16	110435	Nut (4-40 Hex) 1-4, 1-13
2449	Washer, Lock 1-2	80581	Spring 1-16	110436	Spring 1-20
2597	Washer, Flat 1-13	81731	Spring 1-22	110475	Screw (2-64 x 3/32 Spl) 1-27
2669	Washer, Lock (Sev.)	82463	Spring 1-16	110476	Screw (4-48 x 3/32 Spl) 1-27
3438	Washer, Flat 1-6, 1-7	82474	Terminal 1-3, 1-9	110743	Washer, Lock (Sev.)
3595	Nut (1/4-32 Hex) 1-10	82860	Spring 1-21	111017	Screw (6-40 x 5/16 Fil) 1-2, 1-3, 1-27
3598	Nut (6-40 Hex) (Sev.)	85957	Washer, Flat 1-7	111342	Spring 1-10
3599	Nut (4-40 Hex) (Sev.)	86079	Washer, Felt 1-13	111343	Clamp 1-8
3606	Nut (6-40 Hex) 1-8, 1-25	86720	Post, Spring 1-10	111409	Screw (4-40 x 7/32 Fil) 1-25
3640	Washer, Lock 1-25	86742	Nut (4-40 Hex) 1-12, 1-18	111767	Washer, Flat 1-10
3646	Washer, Lock 1-13	86835	Spring 1-2	112626	Nut (10-32 Hex) 1-6, 1-10, 1-11
3949	Collar 1-27	87401	Spring 1-25	112627	Nut (2-56 Hex) 1-18
4703	Spring 1-7	89897	Nut (10-32 Hex) 1-24	112630	Spring 1-7
4707	Washer, Flat 1-24	90260	Spring 1-10	112695	Connector, Plug (3 Pt) 1-23
4809	Wick, Felt 1-4	90573	Spring 1-13	113980	Washer, Flat 1-24, 1-25
5475	Nut (3/16-40) 1-10	90599	Shim (.008") 1-25	117608	Nut, Speed 1-8, 1-9, 1-14, 1-24
5599	Nut (8-32 Hex) 1-27	90679	Washer, Felt 1-10	119467	Insulator 1-24, 1-25
6342	Wire 1-23	90714	Washer, Flat 1-27	119647	Ring, Retaining 1-10
7002	Washer, Flat (Sev.)	90791	Washer, Lock 1-10, 1-13, 1-27	119648	Ring, Retaining (Sev.)
7602	Spring 1-4	90951	Washer, Lock 1-20	119649	Ring, Retaining (Sev.)
7603	Spring 1-4, 1-5, 1-21, 1-22	91683	Nut (15/32-32 Hex) 1-19, 1-26	119650	Ring, Retaining (Sev.)
7655	Spring 1-4	91684	Nut (15/32-32 Ring) 1-19, 1-26	119651	Ring, Retaining (Sev.)
7965	Spring 1-4	91765	Spacer 1-10	119652	Ring, Retaining (Sev.)
8262	Knob 1-27	91904	Washer, Flat 1-8	119653	Ring, Retaining (Sev.)
8330	Washer, Flat 1-27	92626	Stud 1-22	120824	Washer, Felt 1-11
27263	Screw (5-40 x 7/16 Hex) 1-24	92668	Post, Spring 1-10	121018	Nut (4-40 Hex) 1-27
31636	Spring 1-10, 1-20, 1-24	93082	Extension 1-18	121242	Clamp, Cable 1-27
34432	Washer, Flat 1-27	93117	Washer, Lock 1-24, 1-25	121243	Clamp, Cable 1-3, 1-18
41325	Nut (5-40 Hex) 1-24	93118	Washer, Lock 1-13	121244	Clamp, Cable 1-9
41663	Washer, Flat 1-27	93758	Washer, Felt 1-12, 1-21, 1-22	121247	Clamp, Cable 1-3
41732	Plate, Clamp 1-25	94665	Screw, Shoulder (6-40) 1-25	122057	Switch 1-16, 1-25
41733	Insulator 1-25	95499	Screw, Pilot (6-40) 1-20	124610	Plug 1-27
42661	Spring 1-4, 1-24	96646	Screw (6-40 x 3/64 Fil) 1-18	124999	Switch 1-24
42823	Washer, Flat 1-4, 1-11	97143	Jack 1-27	125011	Washer, Flat (Sev.)
45104	Spring 1-20	99220	Spring 1-27	125015	Washer, Flat (Sev.)
49420	Spring 1-10	100149	Stud 1-9, 1-18	125122	Screw (2-56 x 3/4 Fil) 1-24
55669	Spring 1-2, 1-17	101386	Spring 1-12	125126	Screw (2-56 x 9/32 Fil) 1-13
70071	Washer, Lock 1-24	101714	Spring 1-25	125181	Screw (2-56 x 3/8 Fil) 1-2, 1-16, 1-17, 1-18
70388	Spring 1-4	101796	Washer, Felt 1-5, 1-10	125241	Spring 1-18
71073	Washer, Flat 1-10, 1-20	102057	Screw, Shoulder (4-40) 1-2, 1-17	125268	Spring 1-12
72563	Washer, Felt 1-11	102329	Spring, Contact 1-25	128002	Screw (2-56 x 3/16 Fil) 1-10
73008	Washer, Flat 1-10	102330	Spring, Contact 1-25	139012	Solenoid 1-24
73035	Spring 1-16	104710	Bearing, Ball 1-8	139555	Spring 1-9, 1-18
73497	Plug (Red) 1-27	104751	Spring 1-27	150013	Disk, Adjusting 1-11
73844	Washer, Flat 1-12	104807	Washer, Flat 1-4, 1-25		
73894	Screw, Set (6-40) 1-27	104827	Bearing, Ball 1-6		
74291	Bracket 1-25	105551	Shell, Red 1-27		
74613	Screw (4-40 x 1/4 Hex) 1-25	106047	Screw (1/4-32 x 1/2 Hex) 1-2		
74722	Washer, Flat 1-16				
74728	Terminal 1-24				

## NUMERICAL INDEX - SECTION I (Continued)

Part Number	Description and Page Number	Part Number	Description and Page Number	Part Number	Description and Page Number
150026	Lever, Shoe 1-11	151096	Frame, Signal	151213	Stud, Eccentric 1-10
150028	Disk 1-11		Generator 1-10	151215	Shaft 1-10
150029	Wick, Felt 1-11	151097	Shaft 1-13	151216	Detent 1-10
150043	Shoe, Clutch 1-11	151098	Stud 1-12	151217	Roller 1-10
150044	Shoe, Clutch 1-11	151099	Extension 1-10	151218	Rod 1-16
150089	Screw (4-40 x 1/2 Fil) 1-4, 1-27	151100	Gear Set 1-17	151219	Plate 1-6
150241	Spring 1-11	151101	Guide 1-4	151222	Washer, Felt 1-12
150932	Bushing, Shoulder 1-22	151102	Pawl 1-5	151223	Screw, Shoulder (4-40) 1-8
150966	Insulator 1-2	151104	Clip 1-4		
151008	Lever, Latch 1-4	151105	Extension 1-8	151224	Screw, Pilot (6-40) 1-8
151013	Bail 1-8	151106	Plate 1-10		
151014	Link 1-8	151112	Shaft 1-7	151225	Washer, Felt 1-10
151016	Bearing, Roller 1-10	151113	Strip 1-2, 1-3	151226	Strip 1-8, 1-9
151018	Stud 1-10	151115	Plunge 1-7	151227	Bracket 1-8
151023	Guide 1-4	151116	Stud, Locating 1-2, 1-3	151228	Bracket 1-6
151025	Lever, Detent 1-12	151118	Plate, Spacing 1-2, 1-3	151234	Wheel 1-20
151026	Arm, Toggle 1-12			151235	Wheel 1-20
151030	Shaft 1-4	151126	Spacer 1-6	151236	Hub 1-20
151032	Bellcrank 1-4	151127	Shaft 1-6	151237	Spring 1-20
151036	Screw, Shoulder (4-40) 1-4, 1-8	151130	Pinion (14T) 1-17	151239	Pawl 1-20
151037	Lever 1-12	151131	Gear (96T) 1-17	151240	Pawl 1-20
151038	Plate, Guide 1-10	151132	Pinion (17T) 1-17	151241	Lever 1-20
151039	Stud 1-10	151133	Gear (93T) 1-17	151243	Pawl 1-20
151041	Screw, Pilot (4-40) 1-10	151134	Pinion (20T) 1-17	151244	Bushing, Eccentric 1-20
151043	Plate 1-4	151135	Gear (84T) 1-17	151245	Washer, Felt 1-6, 1-20
151045	Bar, Space 1-8	151140	Plate 1-12	151246	Washer, Spacing 1-6, 1-20
151051	Lever, Intermediate 1-12	151145	Screw, Shoulder (2-56) 1-12		
151052	Lever, Selector 1-13	151146	Strap, Mounting 1-2	151286	Keylever Assembly 1-14
151053	Lever, Transfer 1-13	151151	Sleeve, Cam 1-11	151287	Keylever Assembly 1-14
151054	Stud 1-10	151152	Screw (4-40 x 3/16 Hex) 1-4, 1-10, 1-12, 1-13, 1-27	151288	Keylever Assembly 1-14
151055	Post 1-13			151289	Keylever Assembly 1-14
151056	Stud 1-12	151154	Sleeve 1-11	151290	Keylever Assembly 1-14 1-16
151057	Screw, Pilot (1/4-32) 1-10	151157	Shaft 1-11	151291	Keylever Assembly 1-14
151059	Stud 1-12, 1-18	151158	Guide 1-13	151292	Keylever Assembly 1-14
151060	Gear Set 1-17	151159	Bracket 1-7	151293	Keylever Assembly 1-14
151062	Stud 1-13	151161	Shaft 1-13	151294	Keylever Assembly 1-14
151063	Washer, Spacing 1-11	151167	Bracket 1-4	151295	Keylever Assembly 1-14
151064	Plate 1-11	151169	Screw, Adjusting (4-40) 1-13	151296	Keylever Assembly 1-14
151065	Bail 1-13			151297	Keylever Assembly 1-14
151066	Bail 1-10	151170	Box Assembly, Contact 1-13	151298	Keylever Assembly 1-14
151067	Bail 1-10			151299	Keylever Assembly 1-14
151068	Lever, Reset 1-11	151171	Toggle 1-13	151300	Keylever Assembly 1-14
151073	Screw (4-40 x 5/32 Fil) 1-27	151173	Screw, Contact 1-13	151301	Keylever Assembly 1-14
151075	Gear Set 1-17	151176	Base 1-13	151302	Keylever Assembly 1-14
151076	Wedge, Lock 1-8	151177	Terminal 1-13	151303	Keylever Assembly 1-14
151080	Washer, Spacing 1-8	151179	Terminal 1-13	151304	Keylever Assembly 1-14
151081	Retainer, Wedge 1-8	151180	Link 1-13	151305	Keylever Assembly 1-14
151082	Screw, Pilot (4-40) 1-5	151182	Washer, Insulating 1-13	151306	Keylever Assembly 1-14
151084	Bar, Clutch Trip 1-4			151307	Keylever Assembly 1-15
151085	Bar, Code (#5) 1-4	151183	Insulator 1-13	151308	Keylever Assembly 1-14
151086	Bar, Code (#4) 1-4	151184	Extension 1-13	151309	Keylever Assembly 1-14
151087	Bar, Code (#3) 1-4	151185	Guide 1-13	151310	Keylever Assembly 1-14
151088	Bar, Code (#2) 1-4	151188	Guide 1-13	151311	Keylever Assembly 1-14
151089	Bar, Code (#1) 1-4	151189	Bail 1-10	151312	Keylever Assembly 1-14
151090	Screw, Pilot (6-40) 1-4	151190	Lever, Oscillating 1-12	151313	Keylever Assembly 1-14
151091	Plate 1-4			151314	Keylever Assembly 1-14
151092	Frame 1-4	151191	Bracket 1-4	151315	Keylever Assembly 1-14
		151193	Bumper 1-4	151316	Keylever Assembly 1-14
		151201	Wick, Felt 1-11	151317	Keylever Assembly 1-14
		151205	Plate 1-12	151318	Keylever Assembly 1-14
		151207	Stud 1-10	151319	Keylever Assembly 1-14
		151211	Lever, Stop 1-10	151320	Keylever Assembly 1-14
				151321	Keylever Assembly 1-14

## NUMERICAL INDEX - SECTION 1 (Continued)

Part Number	Description and Page Number	Part Number	Description and Page Number	Part Number	Description and Page Number
151322	Keylever Assembly 1-14	151692	Screw (6-40 x 3/16 Fil) (Sev.)	151903	Keylever Assembly 1-14
151325	Cover 1-8	151693	Screw (6-40 x 9/16 Fil) 1-3	151904	Keylever Assembly 1-14
151326	Plate, Sealing 1-8, 1-9	151712	Button, Pivot 1-6	151905	Keylever Assembly 1-14
151329	Switch 1-2, 1-17, 1-18, 1-20	151723	Screw (10-32 x 3/8 Hex) 1-6, 1-27	151906	Keylever Assembly 1-14
151333	Sleeve, Felt 1-11	151724	Screw (10-32 x 5/8 Hex) 1-6	151907	Keylever Assembly 1-14
151335	Stud 1-2	151725	Screw (10-32 x 3/4 Fil) 1-6	151908	Keylever Assembly 1-14
151338	Collar 1-8, 1-9	151728	Spring 1-11	151909	Keylever Assembly 1-14
151341	Lever 1-2, 1-17	151731	Screw (4-40 x 7/8 Fil) 1-13	151910	Keylever Assembly 1-14
151342	Bracket 1-2, 1-17	151737	Screw (4-40 x 11/64 Hex) 1-11	151934	Keylever Conversion 1-14
151346	Screw (6-40 x 3/8 Fil) 1-2, 1-3, 1-4, 1-6, 1-8, 1-9, 1-25, 1-27	151739**	Screw, Identification (6-40) 1-14	152000	Base 1-2
151348	Cable Assembly 1-2, 1-3	151820	Spring 1-13	152001	Keylever Assembly 1-14
151350	Screw, Shoulder (4-40) 1-4	151830	Bar, Upstop 1-4	152002	Keylever Assembly 1-14
151352	Spring 1-7	151832	Screw, Shoulder (6-40) 1-13	152003	Keylever Assembly 1-14
151353	Cover, Label 1-8	151833	Frame, Front 1-8	152004	Keylever Assembly 1-14
151354	Screw (2-56 x 15/32 Fil) 1-8, 1-25	151834	Plate 1-8	152005	Keylever Assembly 1-14
151355	Bar, Lock 1-4	151835	Lever 1-10	152006	Keylever Assembly 1-14
151358	Box, Contact (without Eyelets) 1-13	151837	Stud 1-10	152007	Keylever Assembly 1-15
151359	Cover 1-13	151840	Bail 1-4	152008	Keylever Assembly 1-14
151365	Terminal 1-2	151841	Channel, Lock Ball 1-8	152009	Keylever Assembly 1-14
151367	Plate 1-4	151842	Retainer, Lock Ball 1-8	152010	Keylever Assembly 1-14
151369	Suppressor, Electrical Noise 1-2	151843	Screw, Adjusting (6-40) 1-8	152011	Keylever Assembly 1-14
151391	Label Set 1-8	151844	Screw, Stop (4-40) 1-8	152012	Keylever Assembly 1-14
151395	Spring 1-12	151845	Lever 1-4	152013	Keylever Assembly 1-14
151397	Spring 1-13	151846	Post, Spring 1-16	152014	Keylever Assembly 1-14
151398	Spring 1-13	151848	Lock 1-8	152015	Keylever Assembly 1-14
151399	Bracket 1-2	151849	Guide 1-5	152016	Keylever Assembly 1-14
151413	Washer, Flat 1-27	151851	Lever 1-5	152017	Keylever Assembly 1-15
151415	Block, Terminal 1-2	151852	Lever 1-5	152018	Keylever Assembly 1-15
151416	Nut (6-40 Hex) 1-2	151853	Lever 1-5, 1-21, 1-22	152019	Keylever Assembly 1-15
151444	Bracket 1-25	151854	Lever 1-5	152020	Keylever Assembly 1-15
151574	Grommet 1-19	151855	Lever 1-5	152045	Guard, Gear 1-2
151618	Screw (6-40 x 7/16 Fil) 1-3, 1-6, 1-24	151856	Bracket 1-7	152122	Screw, Shoulder (4-40) 1-7
151626	Terminal 1-18, 1-19, 1-23	151857	Bail 1-7	152130	Keylever Assembly 1-15
151630	Screw (6-40 x 1/4 Hex) 1-8, 1-24	151858	Bail 1-7	152131	Keylever Assembly 1-15
151631	Screw (6-40 x 5/16 Hex) 1-6, 1-22	151859	Link 1-7	152132	Keylever Assembly 1-15
151637	Screw (4-40 x 1/4 Fil) 1-4, 1-8, 1-9, 1-27	151861	Bail 1-7	152133	Keylever Assembly 1-15
151642	Screw (6-40 x 3/4 Fil) 1-27	151862	Bracket 1-7	152134	Keylever Assembly 1-15
151657	Screw (6-40 x 1/4 Fil) 1-2, 1-4, 1-5, 1-18, 1-20, 1-27	151863	Shaft 1-7	152135	Keylever Assembly 1-15
151658	Screw (6-40 x 5/16 Fil) (Sev.)	151867	Bracket 1-9	152136	Keylever Assembly 1-15
151659	Screw (6-40 x 1/2 Fil) 1-8, 1-9	151879	Stud 1-20	152137	Keylever Assembly 1-15
151678	Screw, Pilot (1/4-32) 1-2	151884	Bracket 1-20	152138	Keylever Assembly 1-15
151685	Screw (4-40 x 5/16 Fil) 1-13	151885	Plate, Nut 1-20	152139	Keylever Assembly 1-15
151688	Screw (4-40 x 5/8 Fil) 1-4, 1-25	151886	Stud 1-20	152250	Stud, Eccentric 1-4
		151887	Modification Kit 1-10, 1-16	152296	Bracket 1-4
		151889	Extension 1-4	152318	Switch 1-18
		151893	Plate 1-6	152333	Modification Kit 1-16
		151894	Gear (48T) 1-6	152334	Modification Kit 1-18
		151895	Bushing, Eccentric 1-6	152338	Modification Kit 1-20
		151896	Shaft 1-6	152342	Modification Kit 1-19
		151897	Lever 1-6	152343	Modification Kit 1-17
		151898	Spring 1-6	152344	Modification Kit 1-18
		151899	Nut, Shoulder (2-56 Hex) 1-12	152460	Bracket 1-2
		151901	Keylever Assembly 1-14	152462	Latch 1-2
		151902	Keylever Assembly 1-14	152463	Latch 1-2
				152464	Insulator 1-2
				152465	Connector, Receptacle (20 Pt) 1-23
				152467	Connector, Plug (20 Pt) 1-2
				152493	Lever 1-10
				152764	Gear (81T) 1-17
				152765	Pinion (13T) 1-17
				152766	Gear Set 1-17
				152814	Stud 1-12

## NUMERICAL INDEX - SECTION 1 (Continued)

Part Number	Description and Page Number	Part Number	Description and Page Number	Part Number	Description and Page Number
152815	Lever 1-16	153624	Box Assembly, Contact 1-13	154532	Keylever Assembly 1-15
152839	Spring 1-4			154533	Keylever Assembly 1-15
152873	Latch 1-4	153626	Insulator 1-16	154534	Keylever Assembly 1-15
152874	Shaft 1-4	153627	Screw, Pilot (6-40) 1-16	154535	Keylever Assembly 1-15
152875	Spacer 1-4			154662	Spacer 1-6
152876	Bracket 1-4	153629	Lever 1-16	154663	Shaft 1-6
152877	Bail 1-4	153630	Bracket 1-16	154681	Modification Kit 1-19
152878	Bracket 1-4	153631	Network 1-3, 1-25	154682	Bracket 1-19
152894	Bracket 1-12	153632	Cable Assembly 1-16	154694	Disk 1-11
152904	Keylever Conversion 1-14	153633	Suppression Assembly, Spark 1-3	154783	Modification Kit 1-24, 1-25
152905	Keylever Conversion 1-14	153635	Cable Assembly 1-18	155025	Keylever Assembly 1-15
152906	Keylever Conversion 1-14	153636	Lever 1-18	155026	Keylever Assembly 1-15
		153637	Spring 1-18	155027	Keylever Assembly 1-15
152911	Modification Kit 1-18	153638	Bracket 1-18	155028	Keylever Assembly 1-15
152916	Modification Kit 1-22	153639	Cable Assembly 1-20	155029	Keylever Assembly 1-15
152918	Modification Kit 1-21	153671	Cable Assembly 1-17	155030	Keylever Assembly 1-15
153109	Lever 1-9, 1-18	153672	Cable Assembly 1-18	155031	Keylever Assembly 1-15
153110	Cable Assembly 1-3, 1-9	153674	Cable Assembly 1-3	155032	Keylever Assembly 1-15
		153796	Cable Assembly 1-3, 1-27	155033	Keylever Assembly 1-15
153112	Bracket 1-9	153803	Wire 1-3, 1-23	155034	Keylever Assembly 1-15
153115	Keylever Assembly 1-18	153839	Screw (6-40 x 5/8 Hex) 1-27	155035	Keylever Assembly 1-15
153116**	Plug, Button 1-8, 1-9, 1-14, 1-24			155036	Keylever Assembly 1-15
		153843	Lever 1-16	155037	Keylever Assembly 1-15
153117**	Cover 1-9	153845	Bushing, Eccentric 1-16	155038	Keylever Assembly 1-15
153118	Cover, Label 1-9			155039	Keylever Assembly 1-15
153119	Label Set 1-9	153846	Plate, Nut 1-27	155040	Keylever Assembly 1-15
153243	Bail 1-22	153847	Generator 1-27	155052	Cable Assembly 1-23
153244	Shaft 1-7	153876	Clamp, Cable 1-27	155615	Base 1-2, 1-27
153245	Bracket 1-22	153877	Bracket 1-27	155616	Plate, Sealing 1-8
153246	Bracket 1-22	153878	Link 1-27	155727	Bar, Code 1-25
153247	Lever 1-22	153887	Detent 1-10	155728	Bar, Code 1-25
153248	Bushing, Shoulder 1-21, 1-22	153892	Meter 1-27	155729	Bar, Code 1-25
		153902	Modification Kit 1-16	155731	Bracket, Contact 1-25
153249	Bail 1-22	153952	Cap 1-27	155732	Bracket 1-25
153250	Link 1-22	153955	Lever 1-27	155733	Lever 1-25
153252	Link 1-22	153956	Cover 1-27	155739	Bracket 1-24
153264	Shaft 1-7	153958	Plate, Guide 1-27	155741	Block w/Pin 1-24
153265	Link 1-21	153959	Plate, Cover 1-27	155743	Stud 1-24
153266	Lever 1-21	153969	Slide 1-27	155744	Bail 1-24
153267	Washer, Felt 1-27	153970	Plate, Bearing 1-27	155745	Contact Assembly 1-25
153268	Bracket 1-7	153971	Plunger 1-27	155746	Contact Assembly 1-25
153271	Bail 1-21	153984	Bail 1-27	155747	Cable Assembly 1-25
153273	Link 1-21	153985	Shim 1-27	155752	Sleeve, Insulating 1-23
153274	Lever 1-21	153986	Plate, Identification 1-27	155848	Bracket 1-25
153276	Bracket 1-21			155849	Bracket 1-25
153277	Bail 1-21	153987	Bracket, Slide 1-27	155850	Contact Assembly 1-25
153283	Keylever Assembly 1-15, 1-22	153992	Meter Assembly 1-27	155851	Bracket 1-25
		153993	Pinion (20T) 1-17, 1-27	155859	Screw (4-40 x 1/8 Binding) 1-23
153284	Keylever Assembly 1-15, 1-21	154085	Plate 1-6	155860	Screw (4-40 x 3/8 Rd) 1-23
		154086	Retainer, Wedge Lock 1-8		
153444	Keylever Assembly 1-9	154135	Pawl 1-20	155861	Washer, Lock 1-23
153445	Keylever Assembly 1-9	154520	Keylever Assembly 1-15	157320	Keylever Assembly 1-15
153572	Cable Assembly w/Switch 1-19	154521	Keylever Assembly 1-15	157321	Keylever Assembly 1-15
153589	Switch 1-19	154522	Keylever Assembly 1-15	157322	Keylever Assembly 1-15
153590	Spacer 1-19, 1-26	154523	Keylever Assembly 1-15	157323	Keylever Assembly 1-15
153591	Cable Assembly 1-19	154524	Keylever Assembly 1-15	157325	Keylever Assembly 1-15
153595	Block, Mounting 1-19	154525	Keylever Assembly 1-15	157326	Keylever Assembly 1-15
153619	Board w/Terminals 1-3	154526	Keylever Assembly 1-15	157327	Keylever Assembly 1-15
153620	Insulator 1-3	154527	Keylever Assembly 1-15	157328	Keylever Assembly 1-15
153621	Cable Assembly 1-3	154528	Keylever Assembly 1-15	157329	Keylever Assembly 1-15
153622	Wire 1-3, 1-23	154529	Keylever Assembly 1-15	157330	Keylever Assembly 1-15
153623	Box, Contact (with Eyelets) 1-13	154530	Keylever Assembly 1-15	157331	Keylever Assembly 1-15
		154531	Keylever Assembly 1-15	157332	Keylever Assembly 1-15

## NUMERICAL INDEX - SECTION I (Continued)

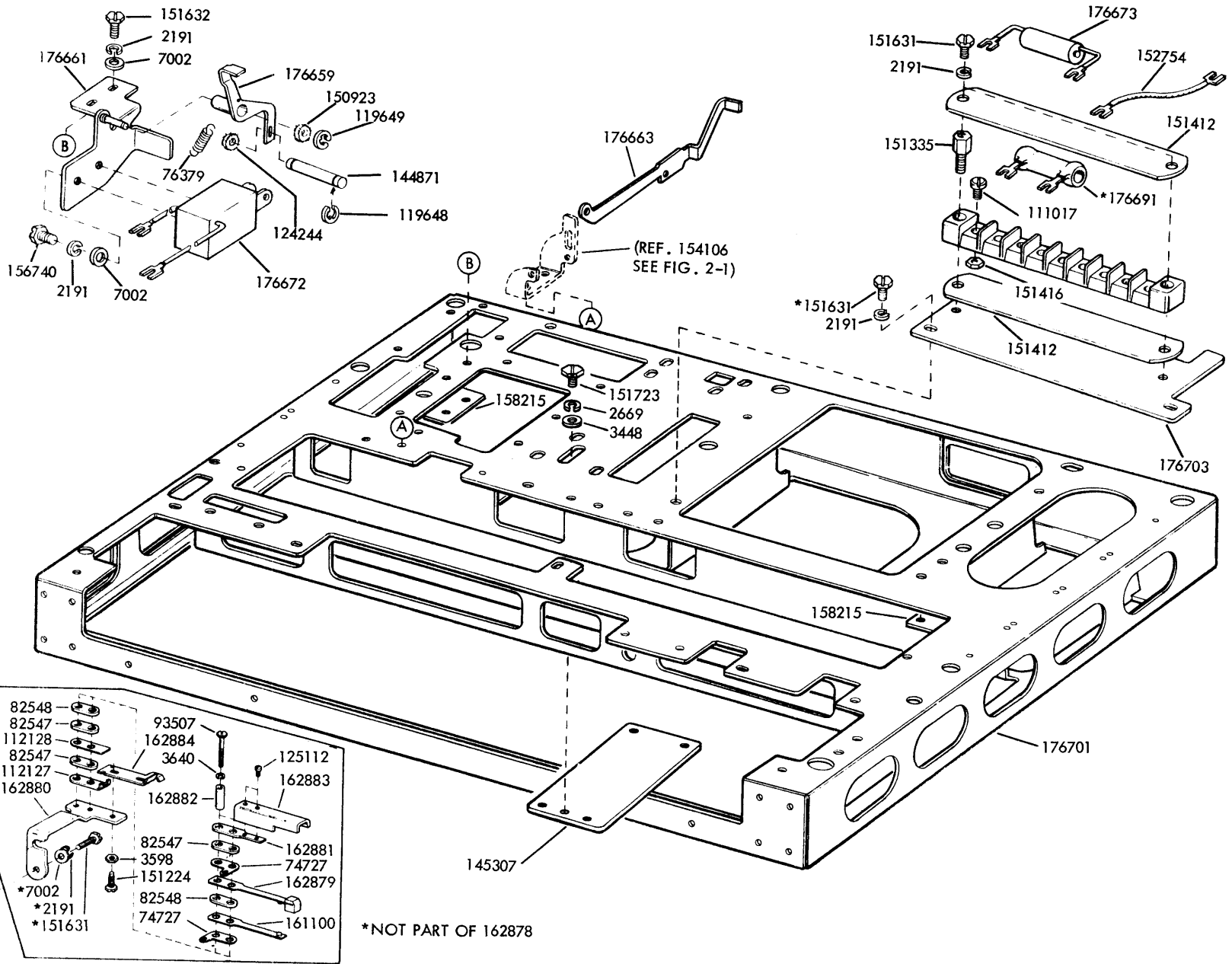
Part Number	Description and Page Number	Part Number	Description and Page Number	Part Number	Description and Page Number
157334	Keylever Assembly 1-15	157963	Keylever Assembly 1-15	158447	Keylever Assembly 1-15
157335	Keylever Assembly 1-15	157964	Keylever Assembly 1-15	158448	Keylever Assembly 1-15
157336	Keylever Assembly 1-15	157965	Keylever Assembly 1-15	158449	Keylever Assembly 1-15
157337	Keylever Assembly 1-15	157966	Keylever Assembly 1-15	158450	Keylever Assembly 1-15
157338	Keylever Assembly 1-15	157967	Keylever Assembly 1-15	158451	Keylever Assembly 1-15
157339	Keylever Assembly 1-15	157968	Keylever Assembly 1-15	158452	Keylever Assembly 1-15
157340	Keylever Assembly 1-15	157969	Keylever Assembly 1-15	158453	Keylever Assembly 1-15
157341	Keylever Assembly 1-15	157970	Keylever Assembly 1-15	158454	Keylever Assembly 1-15
157342	Keylever Assembly 1-15	157971	Keylever Assembly 1-15	158455	Keylever Assembly 1-15
157343	Keylever Assembly 1-15	157989	Hub 1-27	158501	Plate 1-24
157344	Keylever Assembly 1-15	158358	Switch, Toggle 1-26	159278	Pinion (14T) 1-17
157345	Keylever Assembly 1-15	158359	Modification Kit 1-26	159279	Gear (96T) 1-17
157346	Keylever Assembly 1-15	158360	Block, Switch Mounting 1-26	159281	Pinion (17T) 1-17
157347	Keylever Assembly 1-15			159282	Gear (93T) 1-17
157348	Keylever Assembly 1-15	158361	Cable Assembly 1-26	159284	Pinion (20T) 1-17
157349	Keylever Assembly 1-15	158362	Cable 1-26	159285	Gear (84T) 1-17
157350	Keylever Assembly 1-15	158406	Keylever Assembly 1-15	159287	Retainer, Pinion 1-17
157351	Keylever Assembly 1-15	158407	Keylever Assembly 1-15	159660	Gear Set 1-17
157352	Keylever Assembly 1-15	158508	Keylever Assembly 1-15	159661	Pinion (10T) 1-17
157353	Keylever Assembly 1-15	158409	Keylever Assembly 1-15	159662	Gear (57T) 1-17
157354	Keylever Assembly 1-15	158410	Keylever Assembly 1-15	159663	Pinion (15T) 1-17
157355	Keylever Assembly 1-15	158411	Keylever Assembly 1-15	159664	Gear (78T) 1-17
157356	Keylever Assembly 1-15	158412	Keylever Assembly 1-15	159665	Pinion (14T) 1-17
157357	Keylever Assembly 1-15	158413	Keylever Assembly 1-15	159666	Gear (64T) 1-17
157358	Keylever Assembly 1-15	158414	Keylever Assembly 1-15	159667	Gear Set 1-17
157359	Keylever Assembly 1-15	158415	Keylever Assembly 1-15	159668	Pinion (20T) 1-17
157360	Keylever Assembly 1-15	158416	Keylever Assembly 1-15	159669	Gear (70T) 1-17
157361	Keylever Assembly 1-15	158417	Keylever Assembly 1-15	159675	Gear Set 1-17
157362	Keylever Assembly 1-15	158418	Keylever Assembly 1-15	159700	Gear Set 1-17
157363	Keylever Assembly 1-15	158419	Keylever Assembly 1-15	161106	Pinion (14T) 1-17
157364	Keylever Assembly 1-15	158420	Keylever Assembly 1-15	161111	Gear Set 1-17
157365	Keylever Assembly 1-15	158421	Keylever Assembly 1-15	161293	Gear Set 1-17
157366	Keylever Assembly 1-15	158422	Keylever Assembly 1-15	161294	Gear Set 1-17
157367	Keylever Assembly 1-15	158423	Keylever Assembly 1-15	161295	Gear Set 1-17
157940	Keylever Assembly 1-15	158424	Keylever Assembly 1-15	161301	Post 1-17
157941	Keylever Assembly 1-15	158425	Keylever Assembly 1-15	161346	Washer, Felt 1-13
157942	Keylever Assembly 1-15	158426	Keylever Assembly 1-15	161347	Washer, Felt 1-20
157943	Keylever Assembly 1-15	158427	Keylever Assembly 1-15	161348	Spring 1-11
157944	Keylever Assembly 1-15	158428	Keylever Assembly 1-15	161525	Connector, Plug (14 Pt) 1-23
157945	Keylever Assembly 1-15	158429	Keylever Assembly 1-15	162333	Stud 1-2, 1-3
157946	Keylever Assembly 1-15	158430	Keylever Assembly 1-15	162485	Plate 1-10
157947	Keylever Assembly 1-15	158431	Keylever Assembly 1-15	163440	Gear (48T) 1-6
157948	Keylever Assembly 1-15	158432	Keylever Assembly 1-15	163460	Gear (55T) 1-6
157949	Keylever Assembly 1-15	158433	Keylever Assembly 1-15	163461	Pinion (18T) 1-17
157950	Keylever Assembly 1-15	158434	Keylever Assembly 1-15	163462	Gear (117T) 1-17
157951	Keylever Assembly 1-15	158435	Keylever Assembly 1-15	163463	Pinion (24T) 1-17
157952	Keylever Assembly 1-15	158436	Keylever Assembly 1-15	163464	Gear (104T) 1-17
157953	Keylever Assembly 1-15	158437	Keylever Assembly 1-15	163504	Gear Set 1-17
157954	Keylever Assembly 1-15	158438	Keylever Assembly 1-15	163505	Gear Set 1-17
157955	Keylever Assembly 1-15	158439	Keylever Assembly 1-15	163816	Switch (Red) 1-9
157956	Keylever Assembly 1-15	158440	Keylever Assembly 1-15	163817	Switch (Black) 1-9
157957	Keylever Assembly 1-15	158441	Keylever Assembly 1-15	163852	Keylever Assembly 1-15
157958	Keylever Assembly 1-15	158442	Keylever Assembly 1-15	163962	Plate 1-9
157959	Keylever Assembly 1-15	158443	Keylever Assembly 1-15	164132**	Cover 1-9
157960	Keylever Assembly 1-15	158444	Keylever Assembly 1-15	164133	Cable 1-9, 1-23
157961	Keylever Assembly 1-15	158445	Keylever Assembly 1-15	164327	Cable 1-23
157962	Keylever Assembly 1-15			164434	Keylever Assembly 1-14
				164435	Keylever Assembly 1-14
				164457	Keylever Assembly 1-15

**SECTION 2**  
**MARK III KEYBOARD**





FIGURE 2-1A. KEYBOARD BASE MECHANISM FOR REMOTE CONTROLLED GEAR SHIFT MECHANISM



1149B

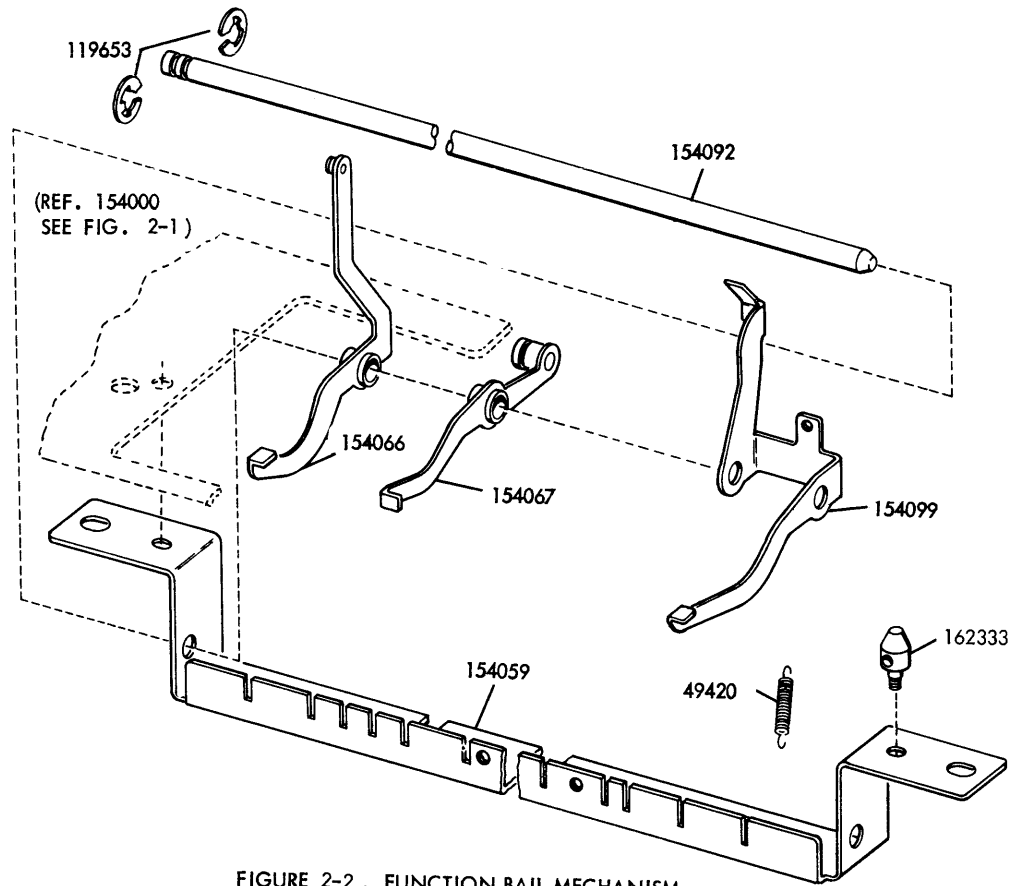
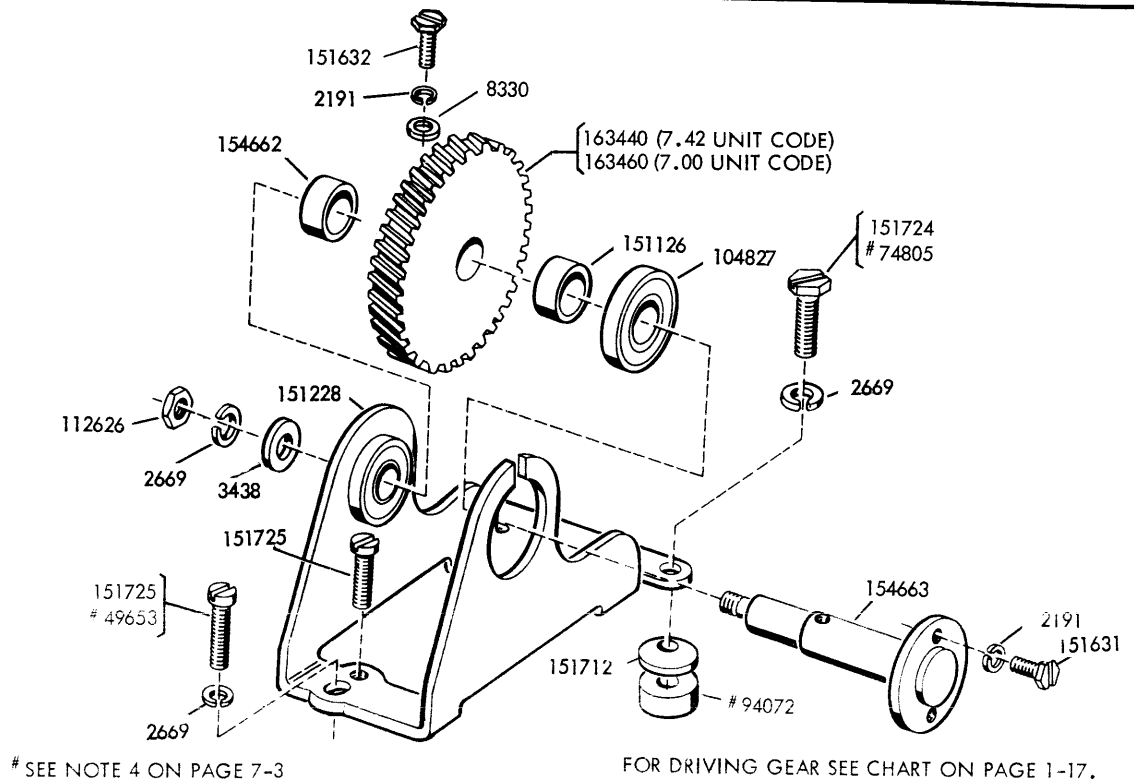


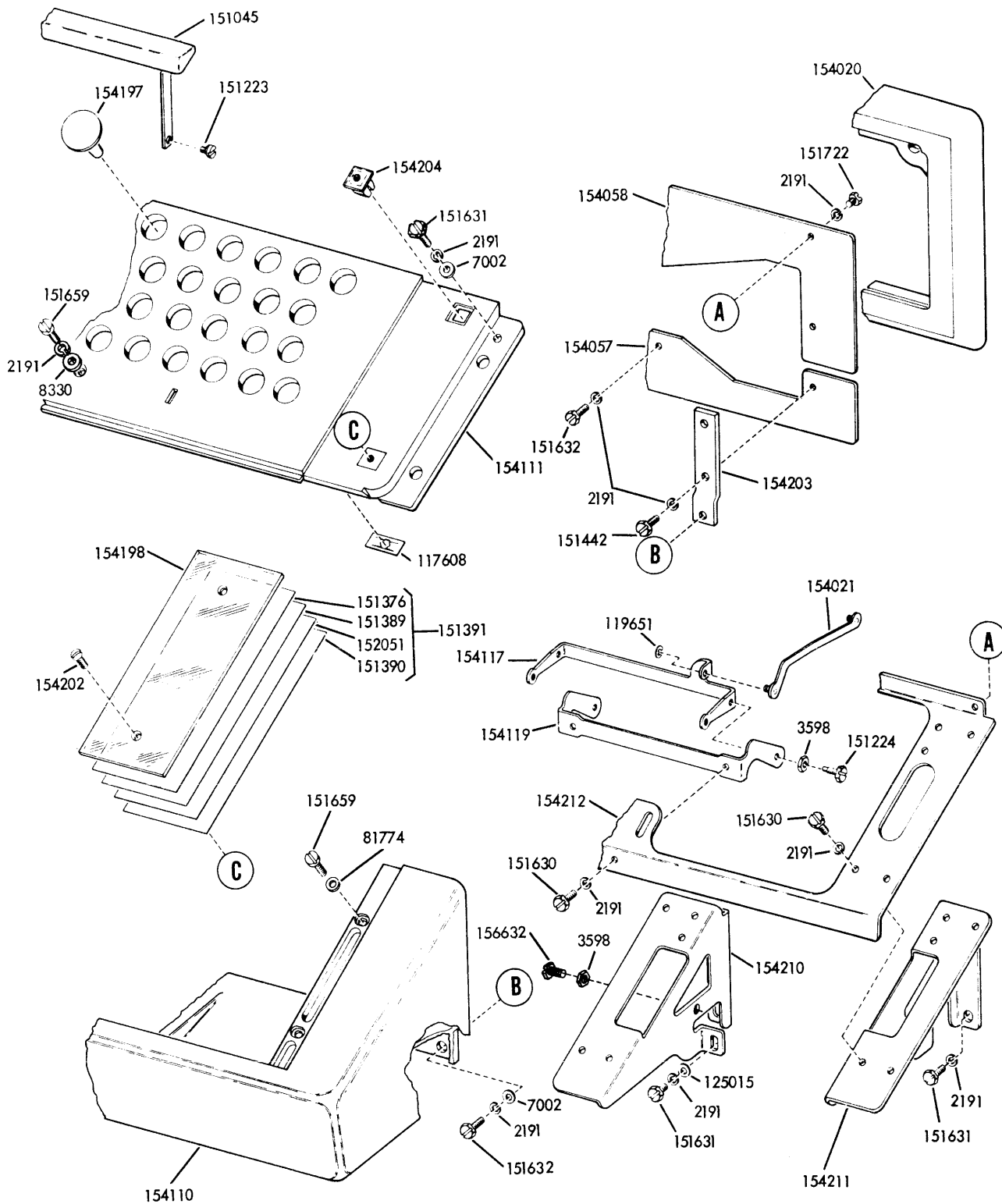
FIGURE 2-2 . FUNCTION BAIL MECHANISM



# SEE NOTE 4 ON PAGE 7-3

FOR DRIVING GEAR SEE CHART ON PAGE 1-17.

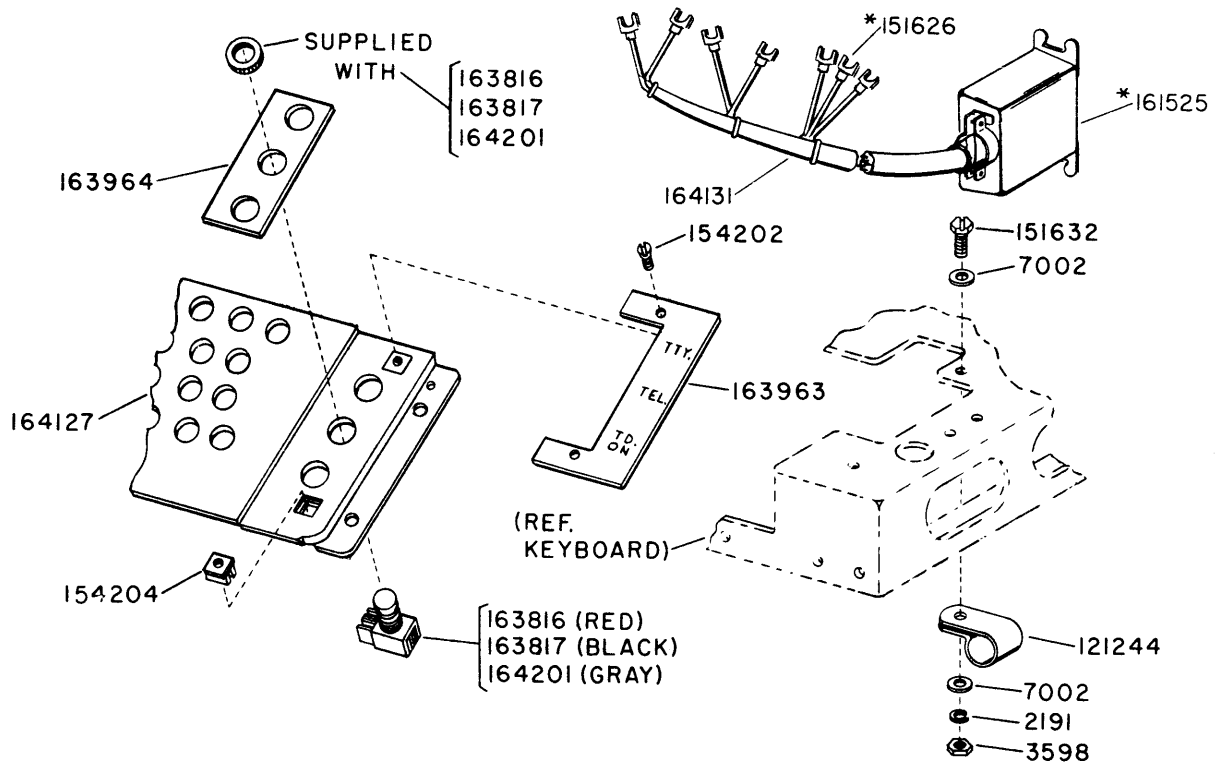
FIGURE 2-3 INTERMEDIATE GEAR MECHANISM



FOR KEYLEVER ASSEMBLIES  
SEE PAGES 1-14 AND 1-15.

FIGURE 2-4. KEYBOARD MECHANISM

1149B



\*PART OF 164131

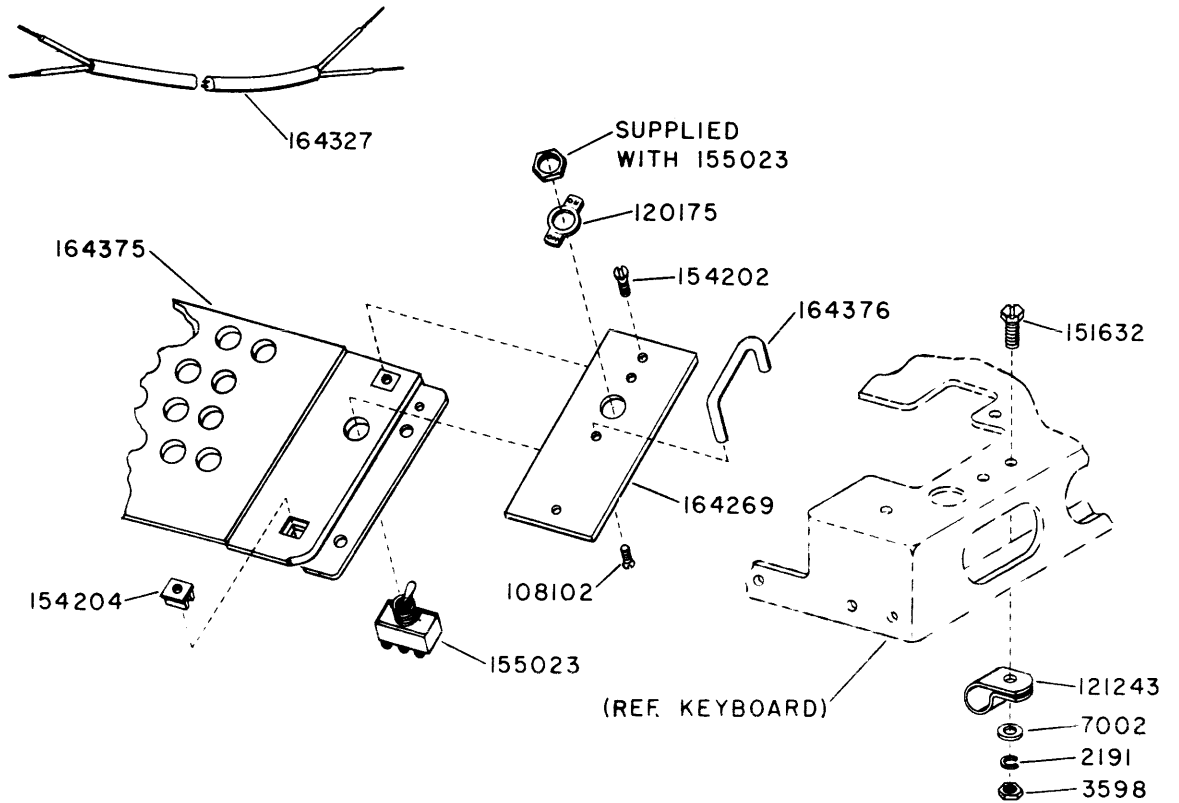
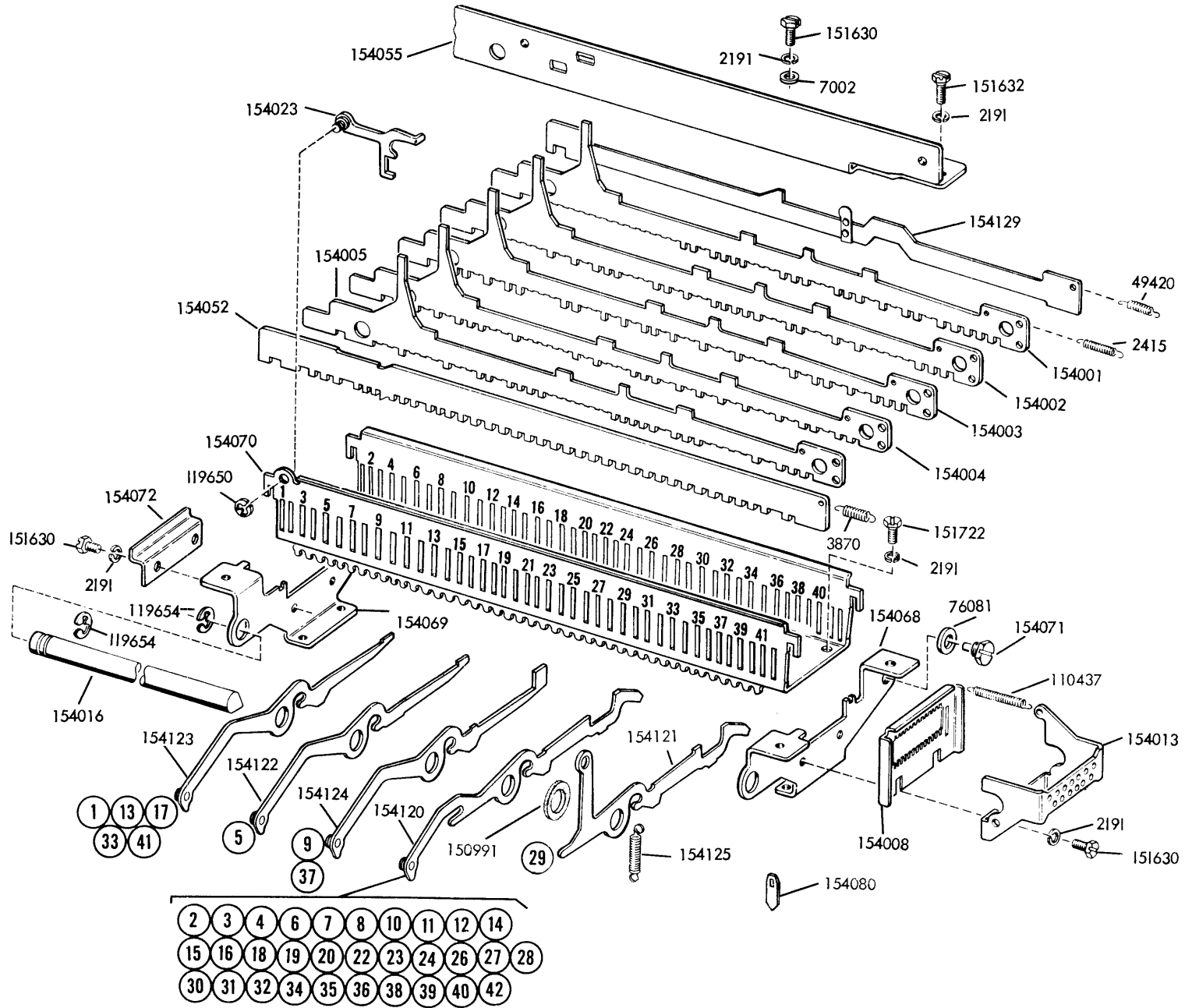


FIGURE 2-5. VARIABLE FEATURES OF KEYBOARD MECHANISM

FIGURE 2-6. CODE BAR MECHANISM



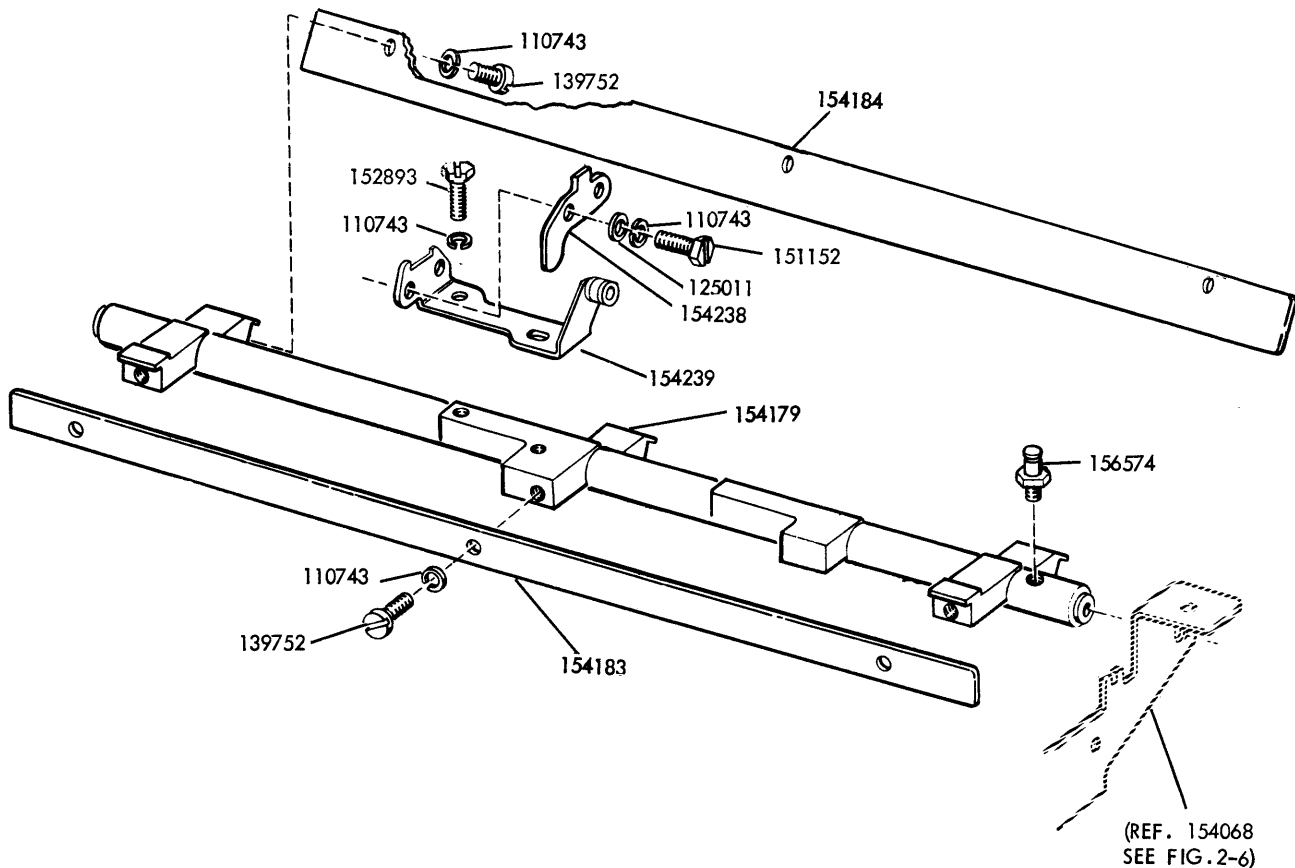
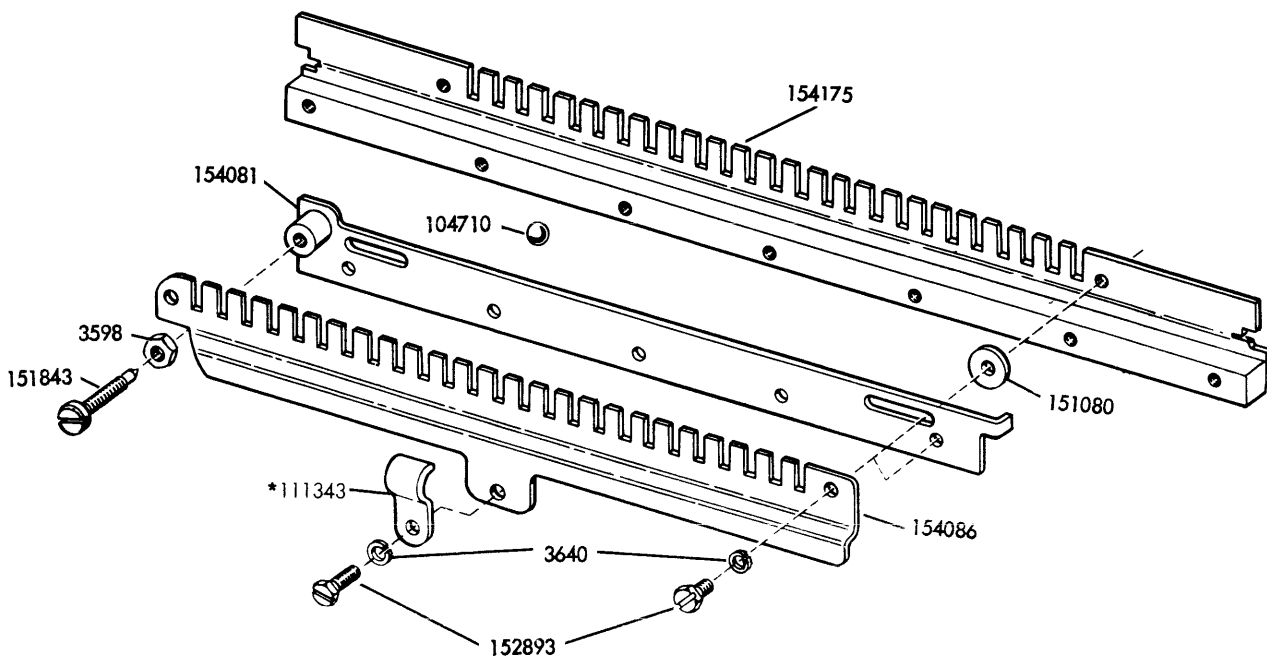
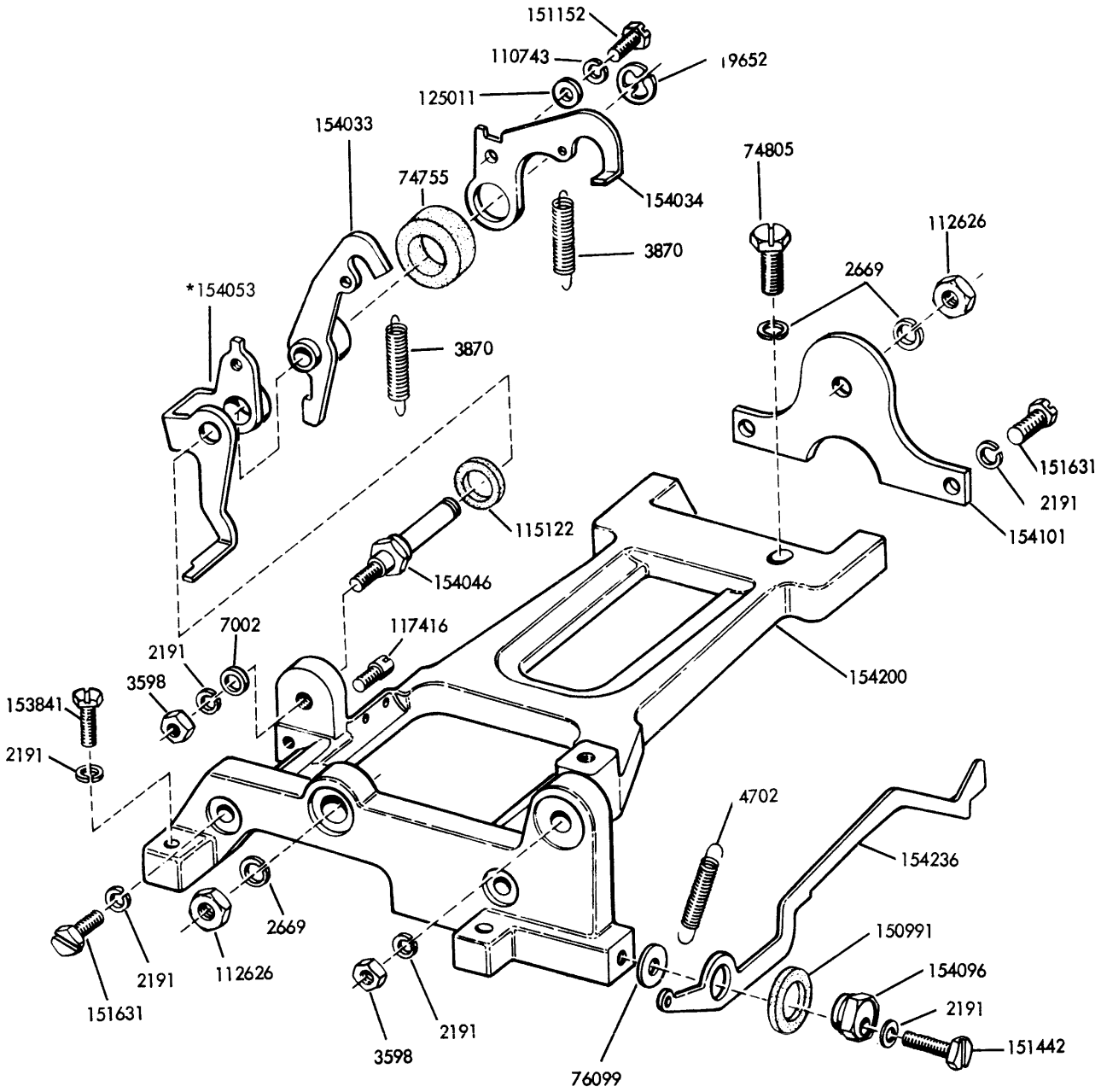


FIGURE 2-7. UNIVERSAL BAIL MECHANISM



\*SEE NOTE 1 ON PAGE 7-3.

FIGURE 2-8. BALL LOCK MECHANISM



\*SEE NOTE 2 ON PAGE 7-3.

FIGURE 2-9. SIGNAL GENERATOR FRAME MECHANISM

FIGURE 2-10. SIGNAL GENERATOR SHAFT MECHANISM

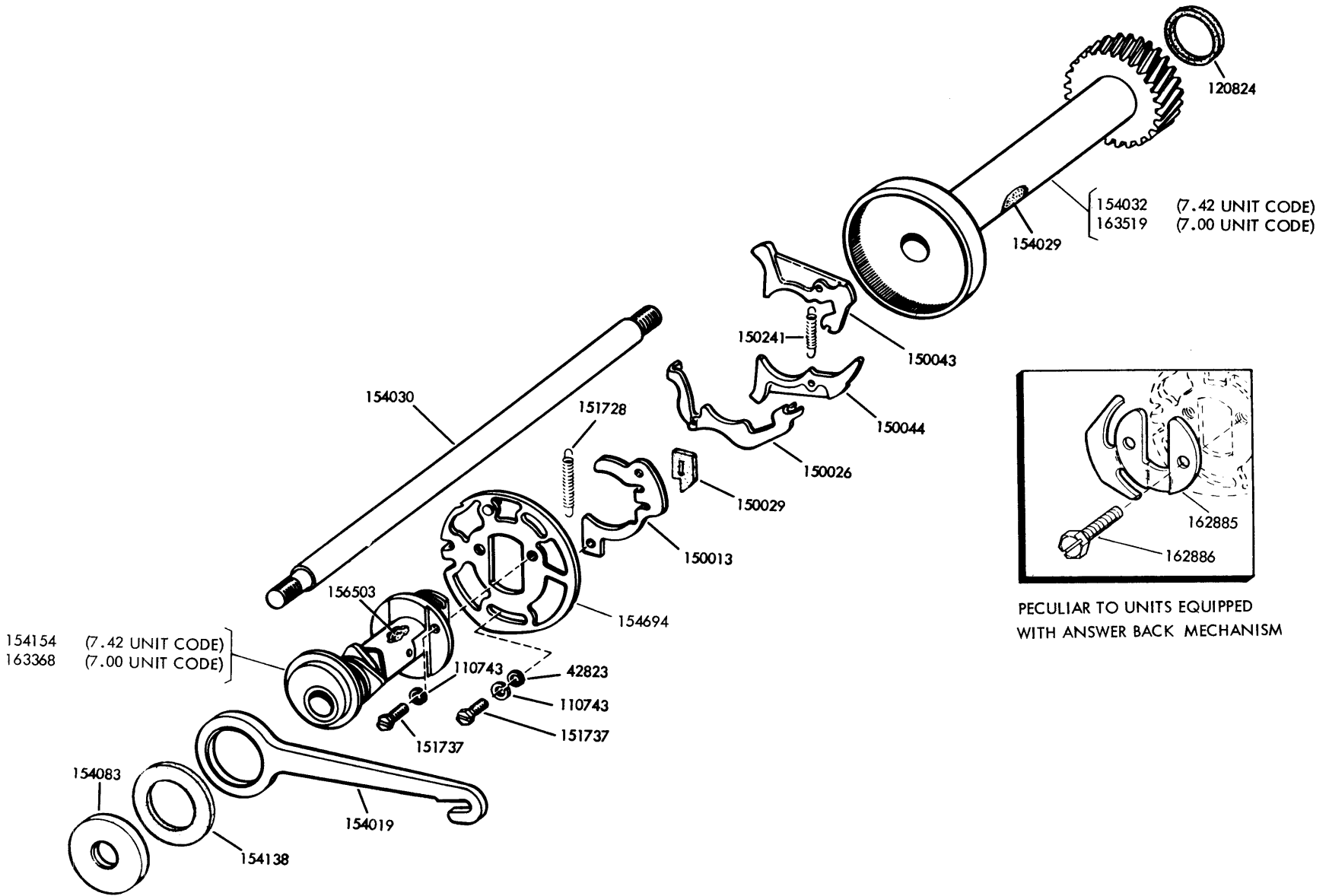




FIGURE 2-11. SIGNAL GENERATOR FRONT PLATE MECHANISM.

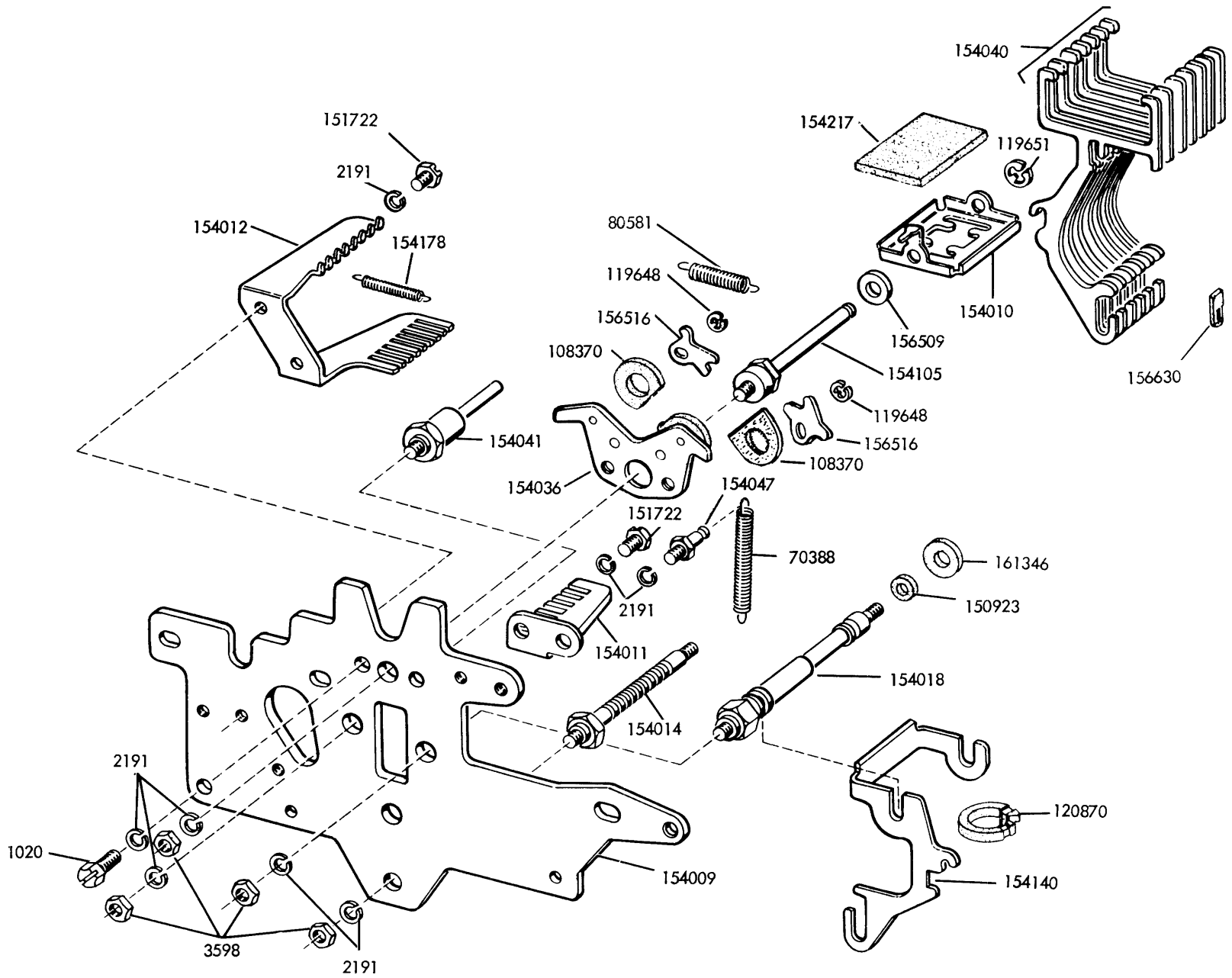
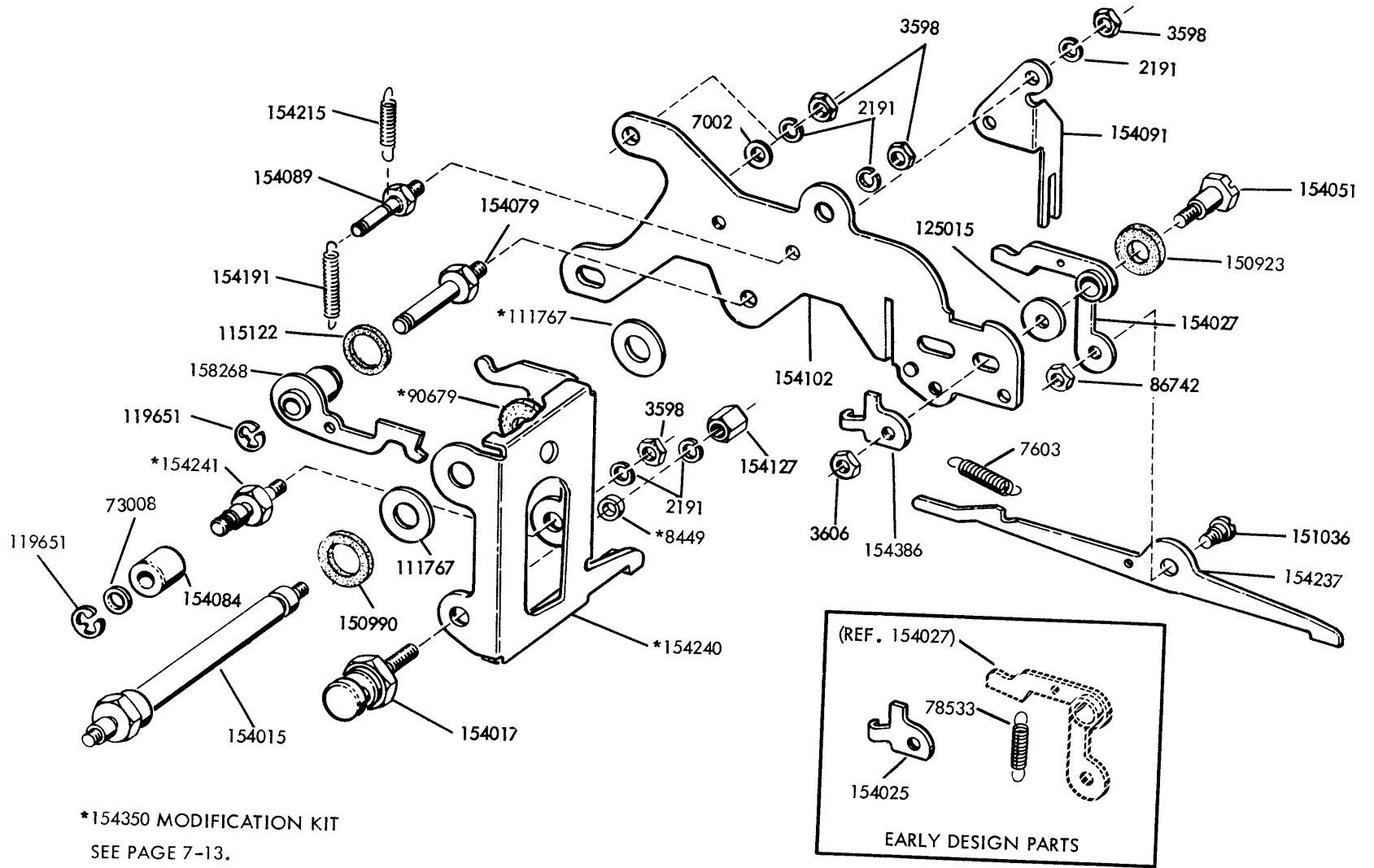
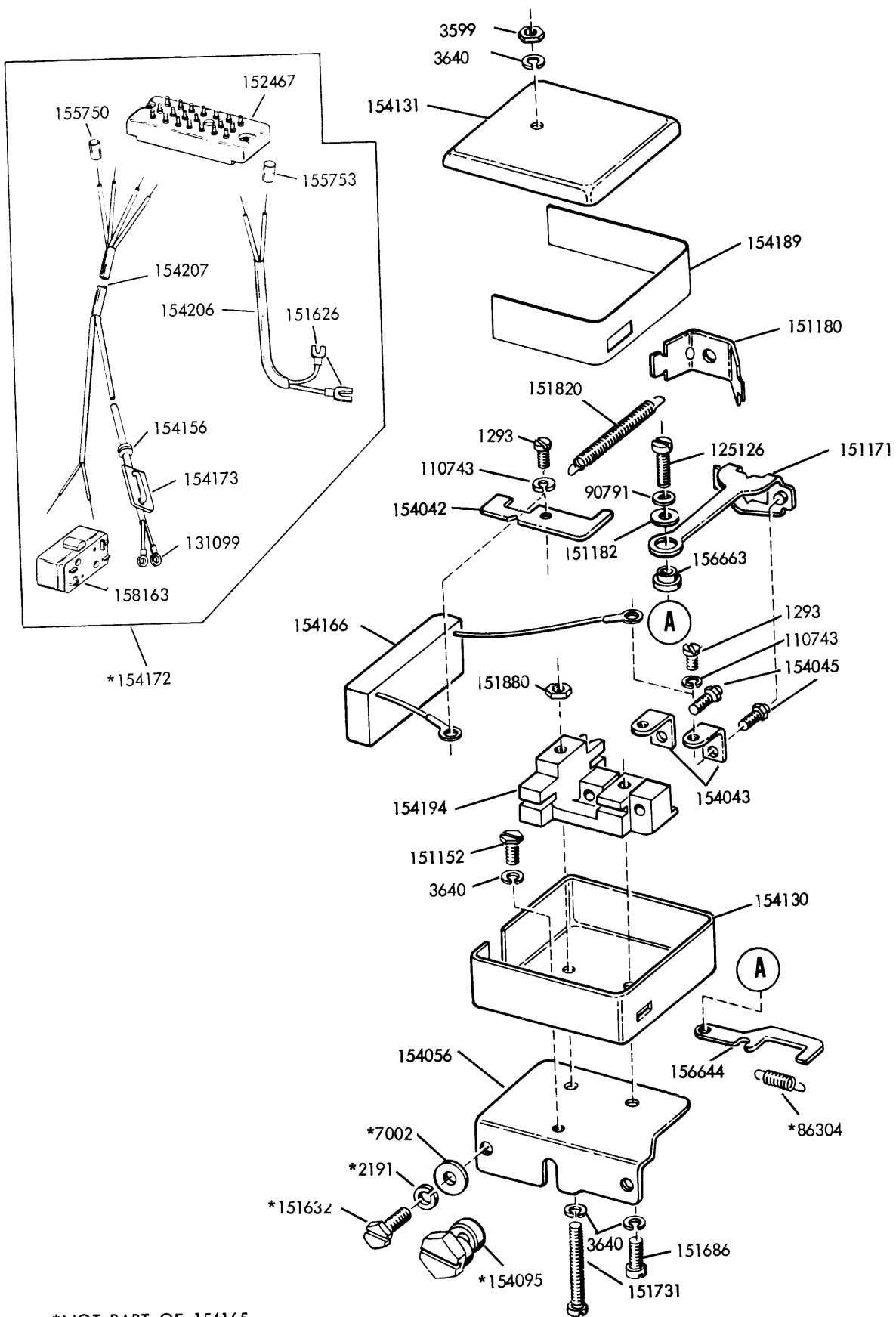


FIGURE 2-12. SIGNAL GENERATOR REAR PLATE MECHANISM



1149B



\*NOT PART OF 154165

FIGURE 2-13. 154165 CONTACT BOX ASSEMBLY WITH ARC SUPPRESSION - NEUTRAL TRANSMISSION

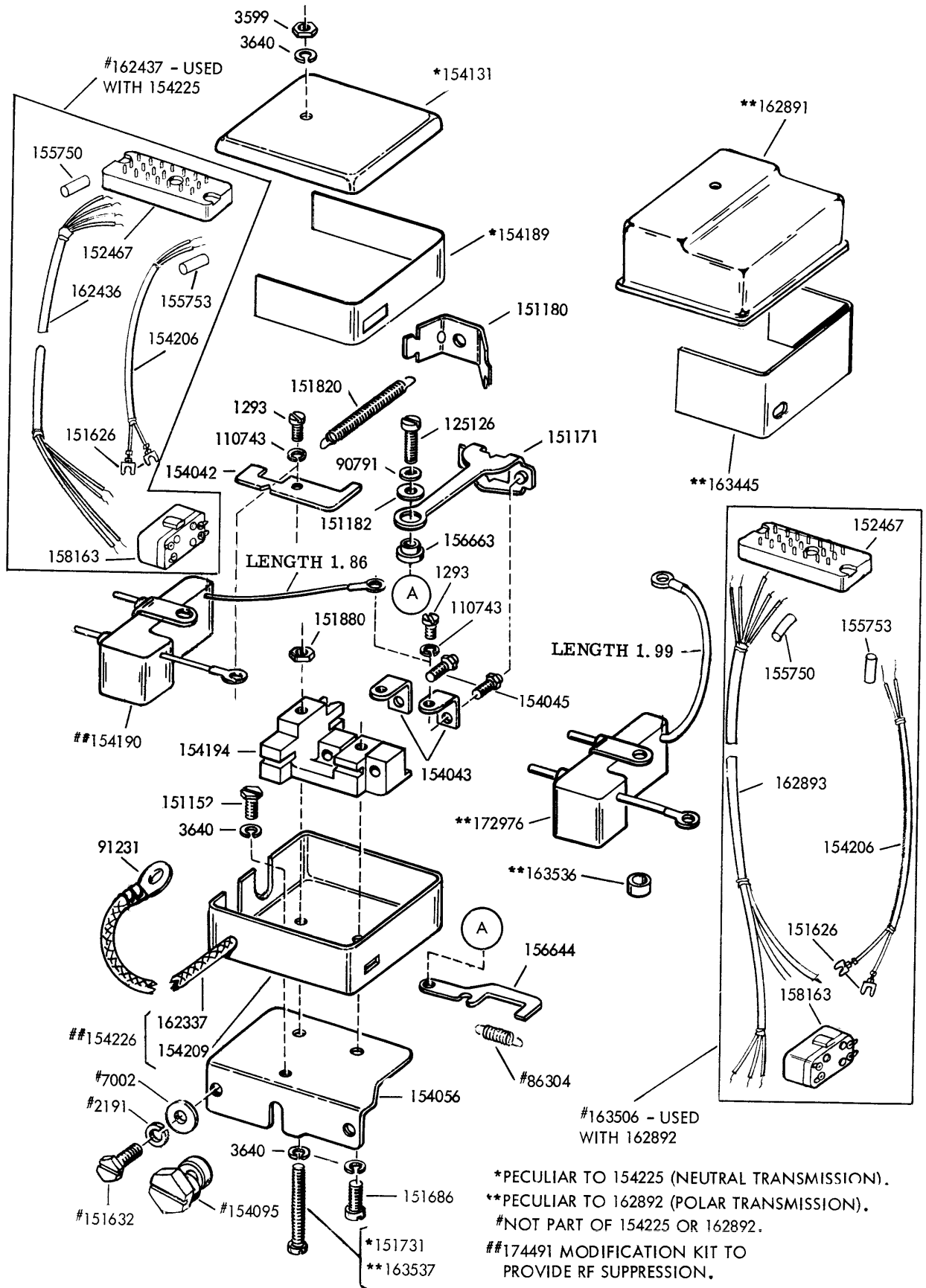


FIGURE 2-14. 154225 AND 162892 CONTACT BOX ASSEMBLIES WITH RF SUPPRESSION - NEUTRAL AND POLAR TRANSMISSION

DRIVEN WHEEL DIAMETER	DRIVEN WHEEL	"O" RING BELT
6-3/16"	164723	164734
5-1/2"	*146313	*146314

SPECIFICATION 59825

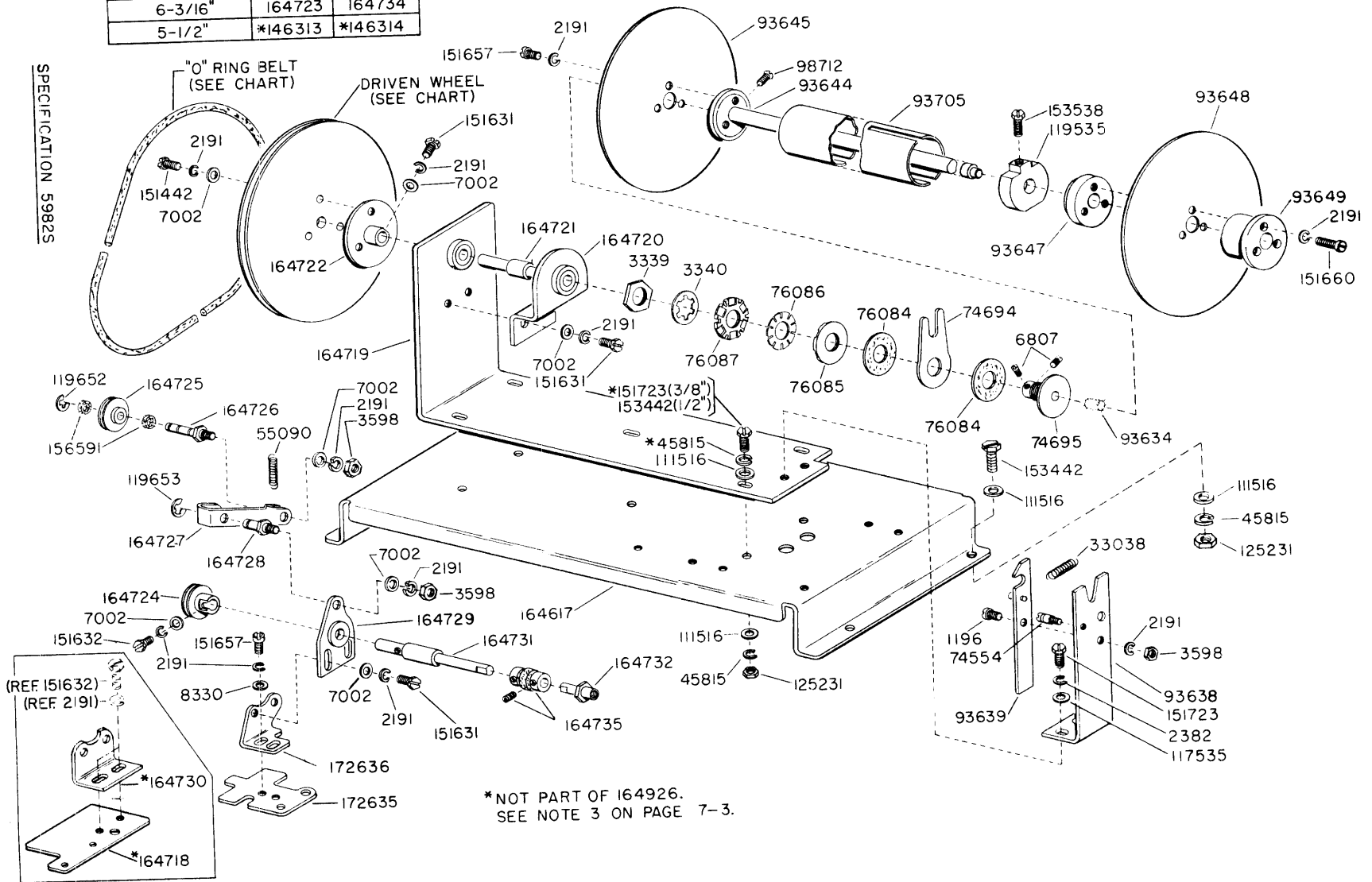
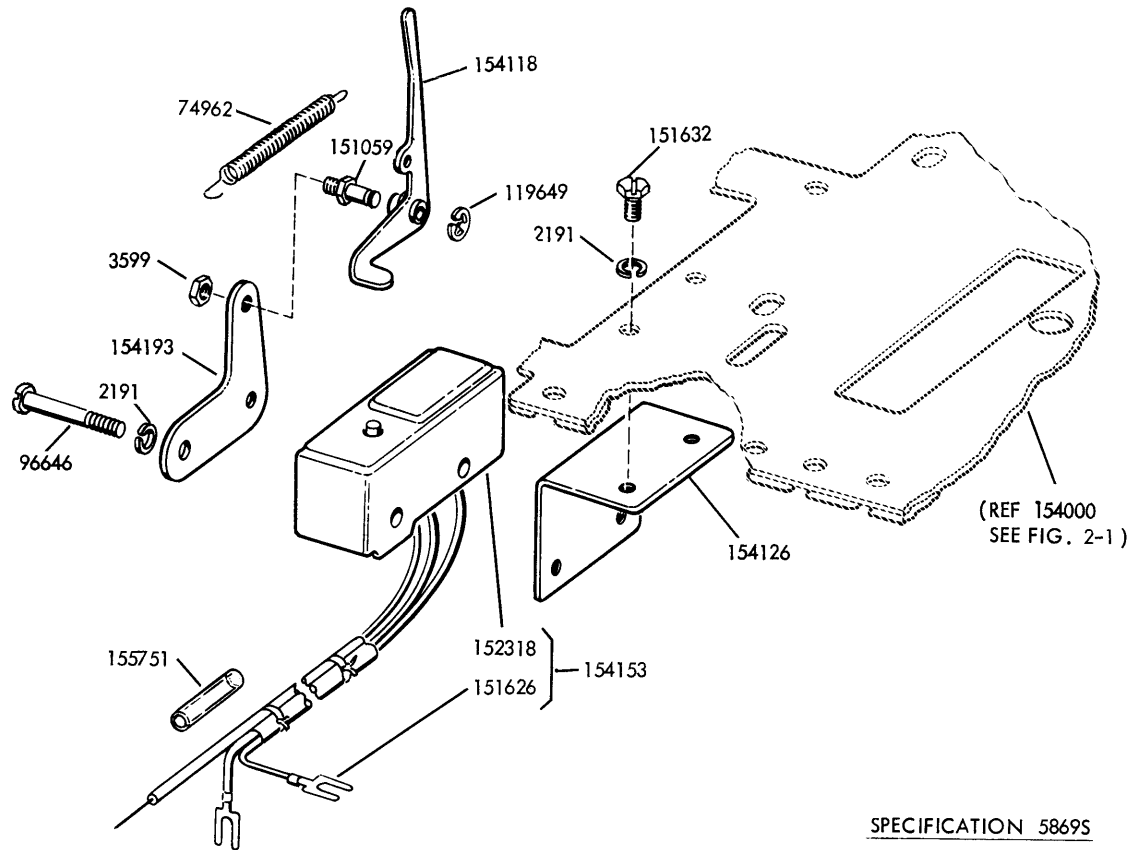


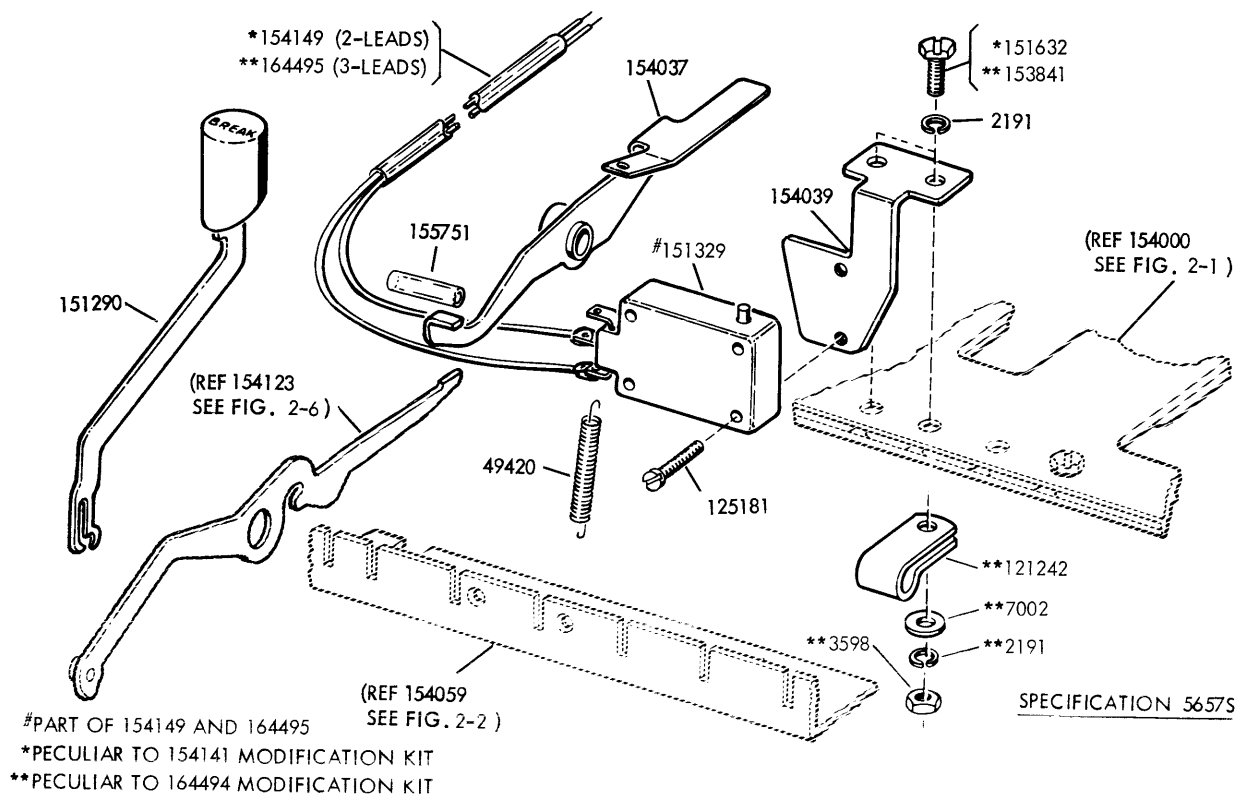
FIGURE 2-15. 164926 MODIFICATION KIT TO PROVIDE PAPER WINDING FACILITIES FOR SEND-RECEIVE AND RECEIVE-ONLY BASES MOUNTED IN AN APPARATUS CABINET (LBAC)

CHANGE II



SPECIFICATION 5869S

FIGURE 2-16. 154147 MODIFICATION KIT TO PROVIDE LOCAL PAPER FEED-OUT MOTOR STARTING MECHANISM (MARK III KEYBOARD)

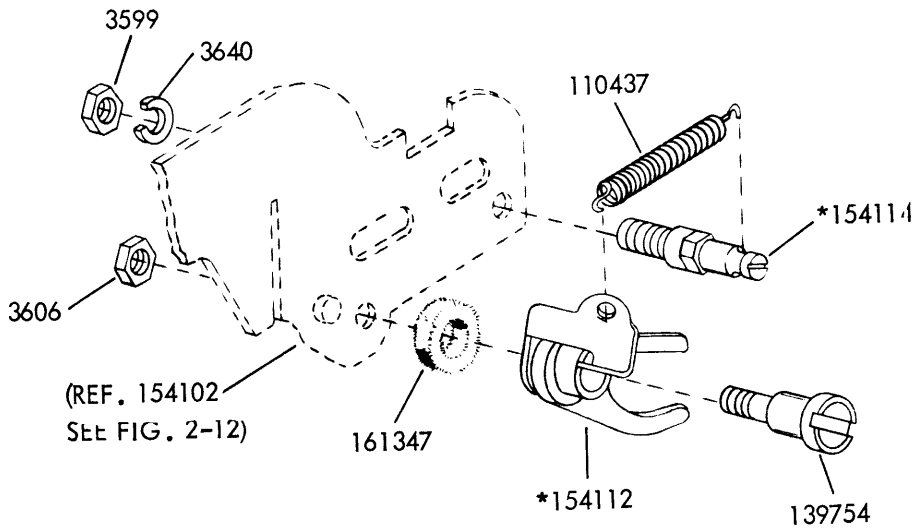


SPECIFICATION 5657S

- #PART OF 154149 AND 164495
- \*PECULIAR TO 154141 MODIFICATION KIT
- \*\*PECULIAR TO 164494 MODIFICATION KIT

FIGURE 2-17. 154141 AND 164494 MODIFICATION KIT TO PROVIDE ELECTRICAL SIGNAL LINE BREAK MECHANISM (MARK III KEYBOARD)

1149B



\*NOT AVAILABLE (ORDER 163775).

FIGURE 2-18. OLD STYLE REPEAT ON SPACE MECHANISM

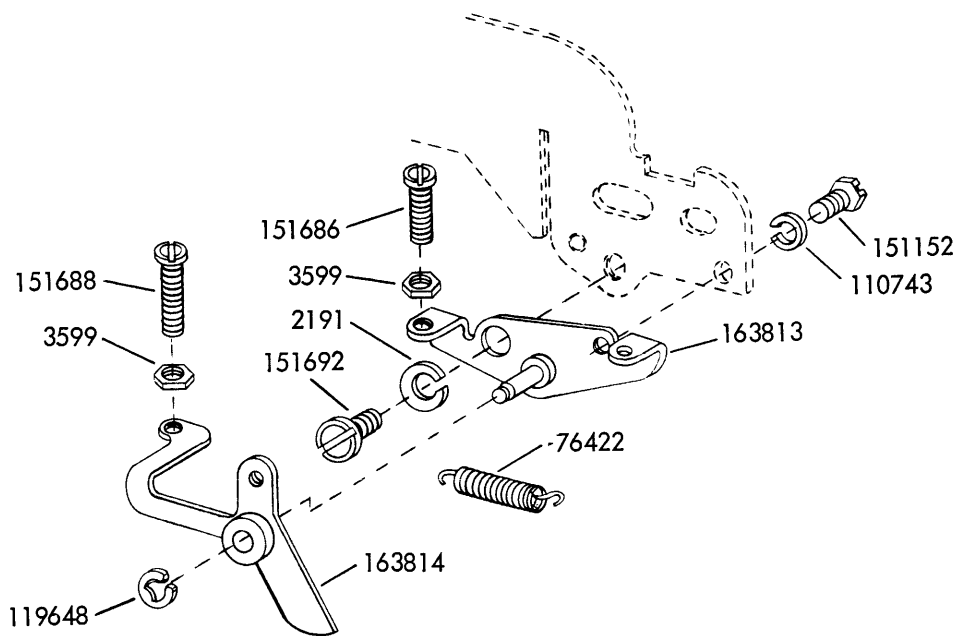
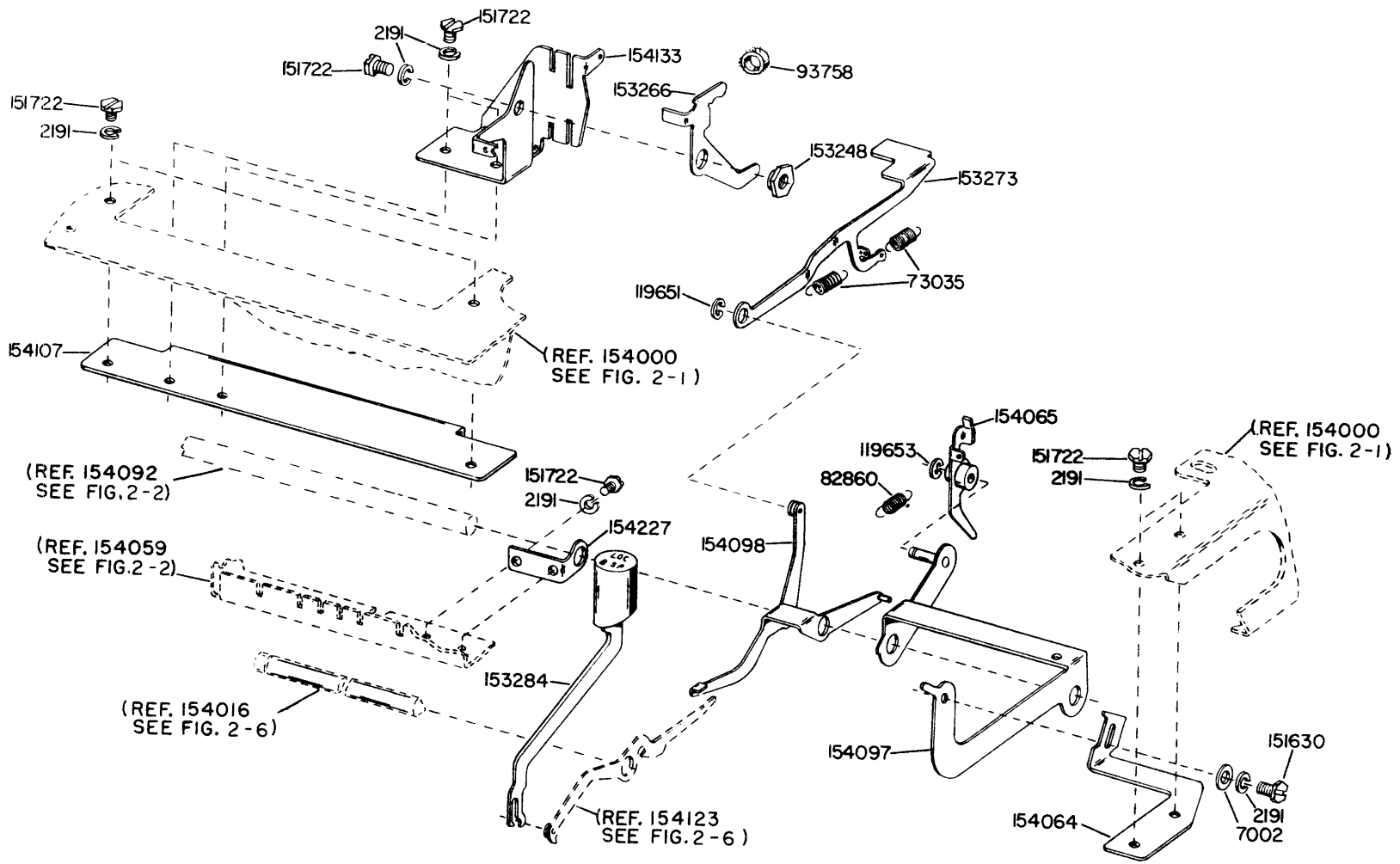


FIGURE 2-19. 163775 MODIFICATION KIT TO PROVIDE REPEAT ON SPACE MECHANISM (MARK III KEYBOARD)

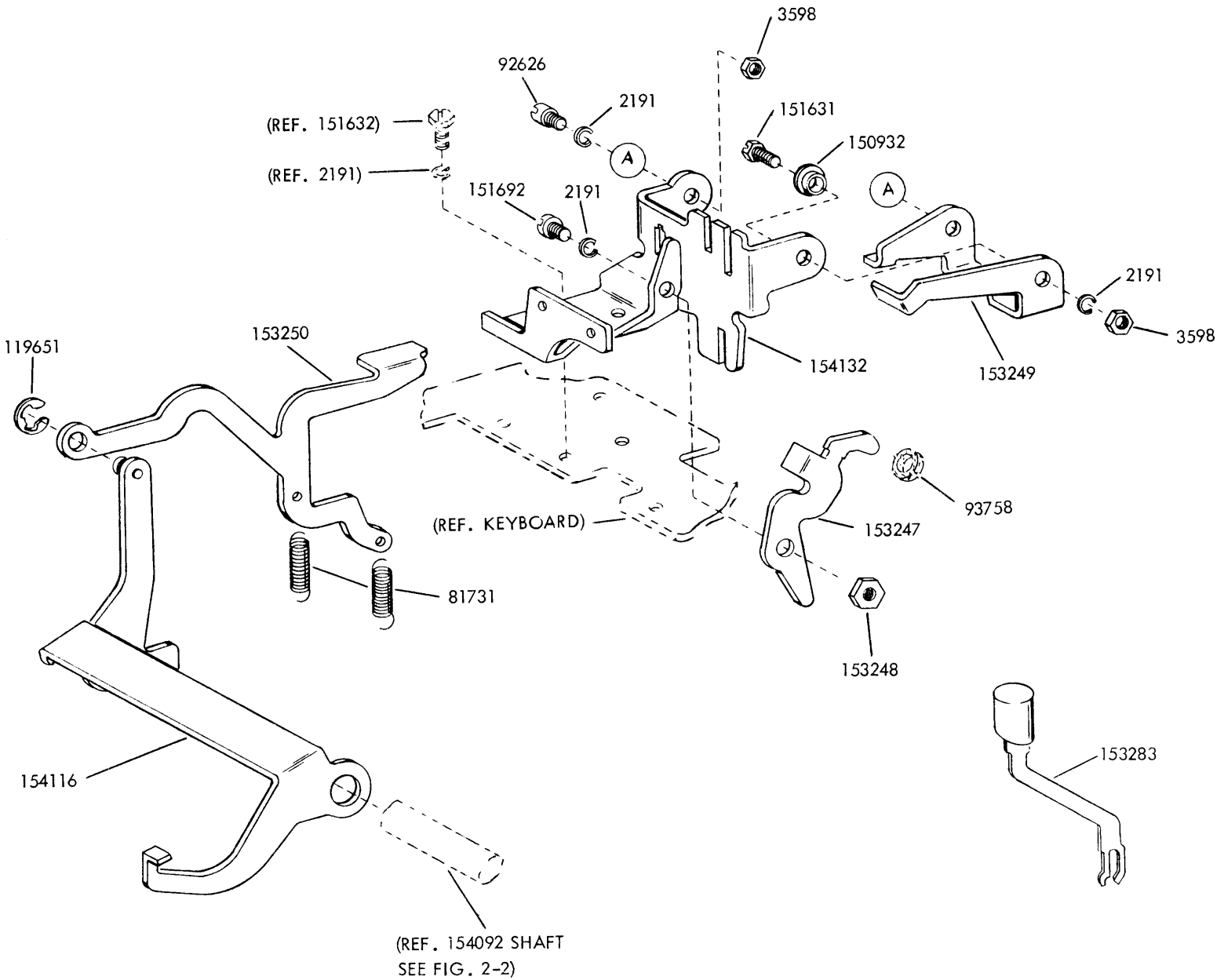


SPECIFICATION 5766S

FIGURE 2-20. 154146 MODIFICATION KIT TO PROVIDE LOCAL BACK SPACE MECHANISM (MARK III KEYBOARD)

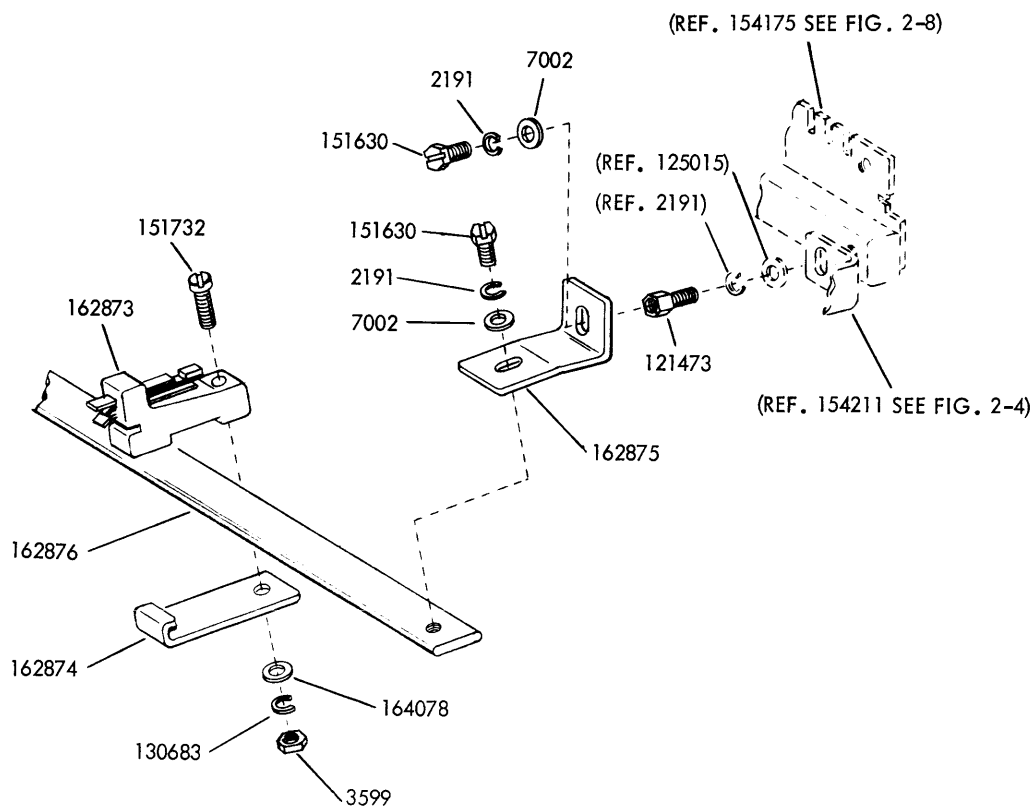
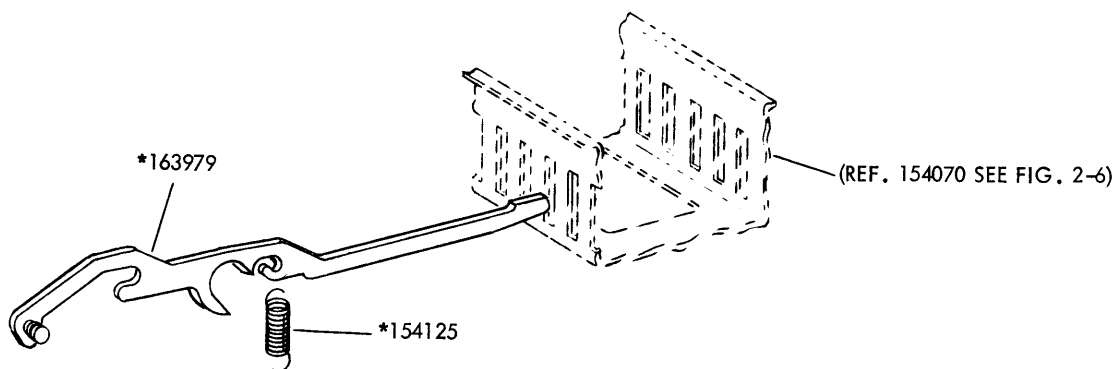
CHANGE 9





SPECIFICATION 5765S

FIGURE 2-21. 154145 MODIFICATION KIT TO PROVIDE LOCAL REVERSE LINE FEED MECHANISM  
(MARK III KEYBOARD)



\*NOTE: REQUIRED ONLY WHEN ADDITIONAL KEYLEVER IS USED.

SPECIFICATION 59725

FIGURE 2-22. 164005 MODIFICATION KIT TO PROVIDE UNIVERSAL KEYBOARD SWITCH MECHANISM (MARK III KEYBOARD)

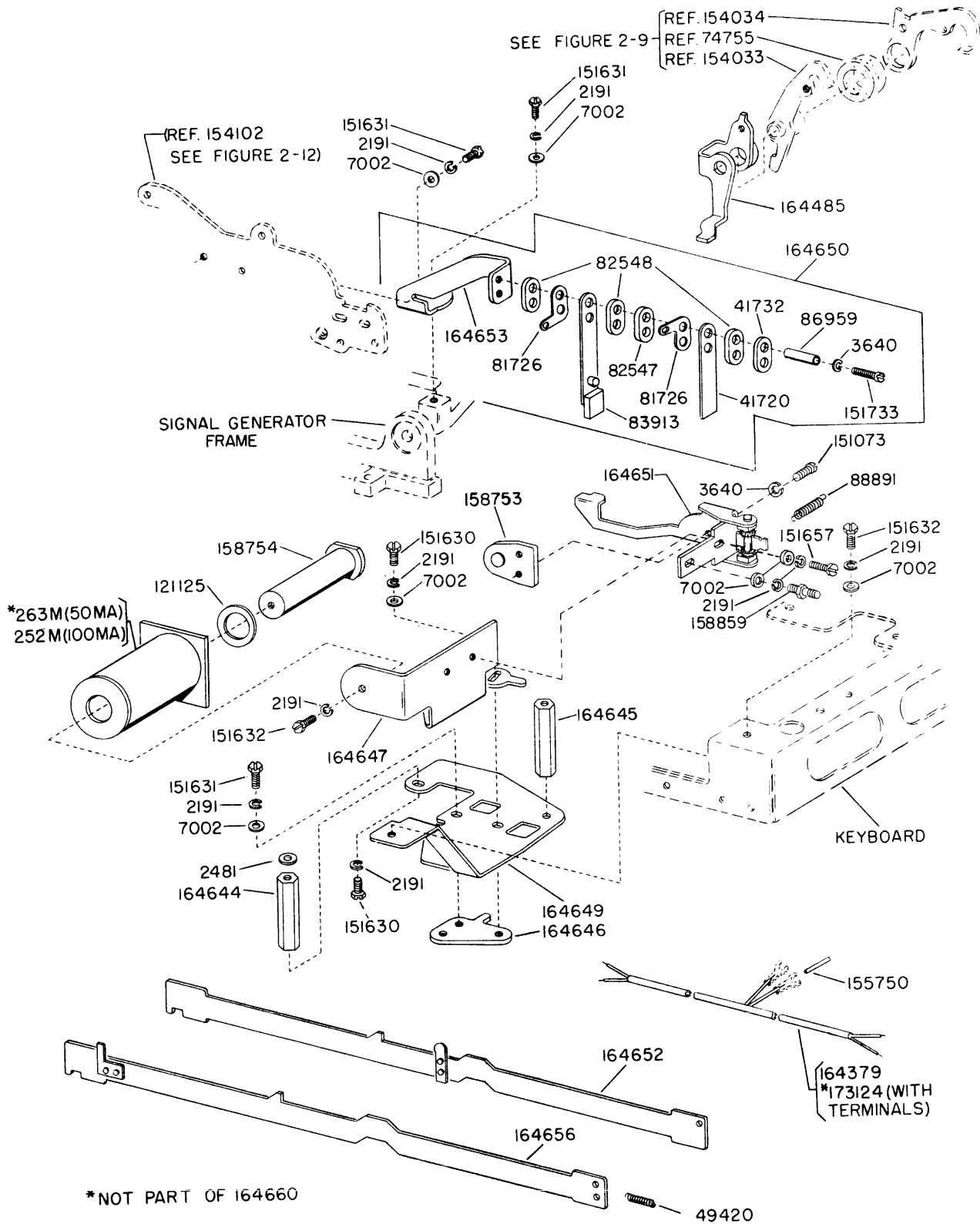
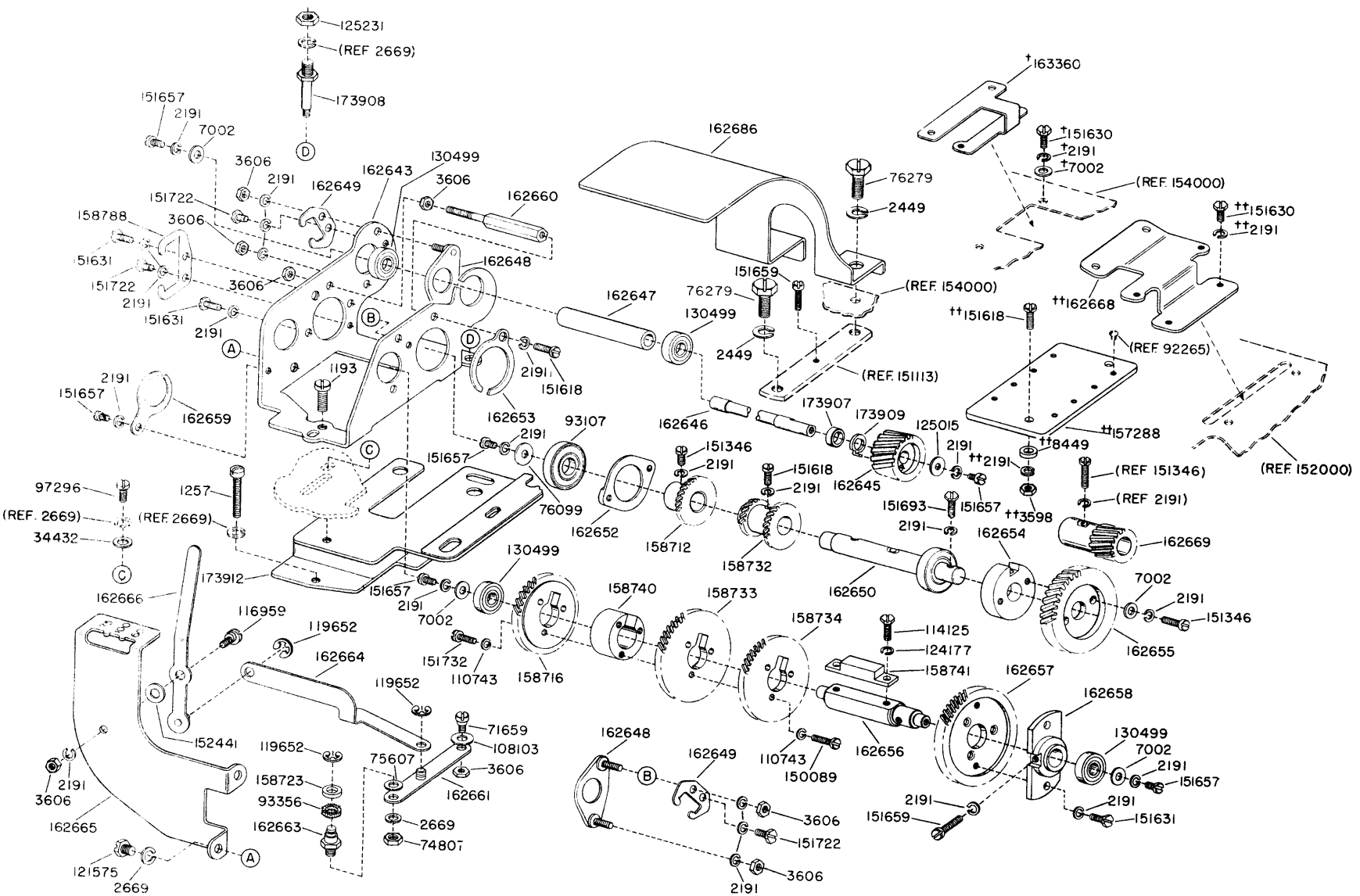


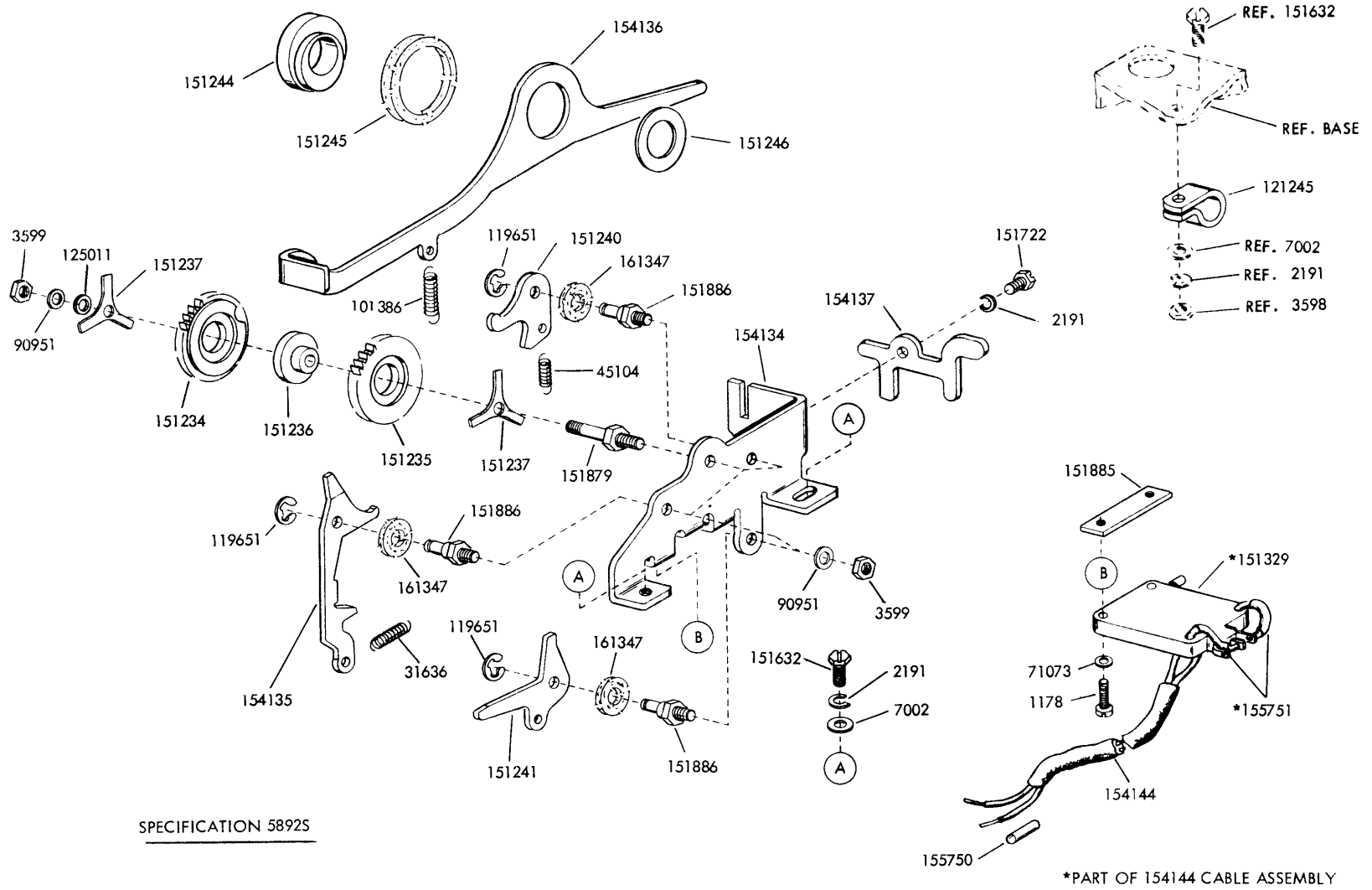
FIGURE 2-23. 164660 MODIFICATION KIT TO PROVIDE SYNCHRONOUS PULSED TRANSMISSION-100MA (MARK III KEYBOARD)



† PECULIAR TO 163359  
 †† PECULIAR TO 162641

FIGURE 2-24 162641 MODIFICATION KIT TO PROVIDE VARIABLE GEAR SHIFT MECHANISM (MARK II KEYBOARD OR BASE)  
 163359 MODIFICATION KIT TO PROVIDE VARIABLE GEAR SHIFT MECHANISM (MARK III KEYBOARD)

FIGURE 2-25. 154142 MODIFICATION KIT TO PROVIDE KEYBOARD WITH TIME DELAY MECHANISM (MARK III KEYBOARD)



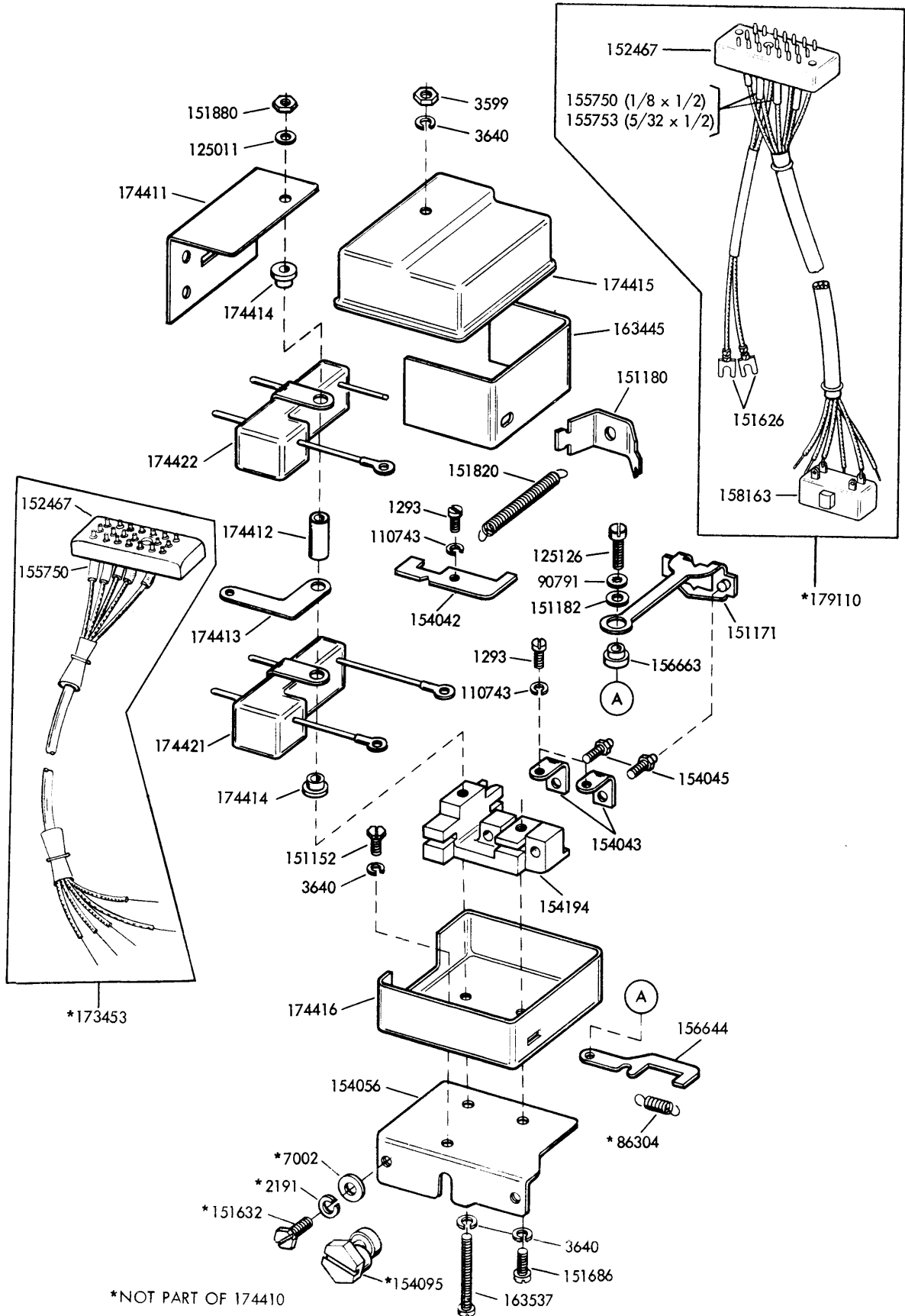
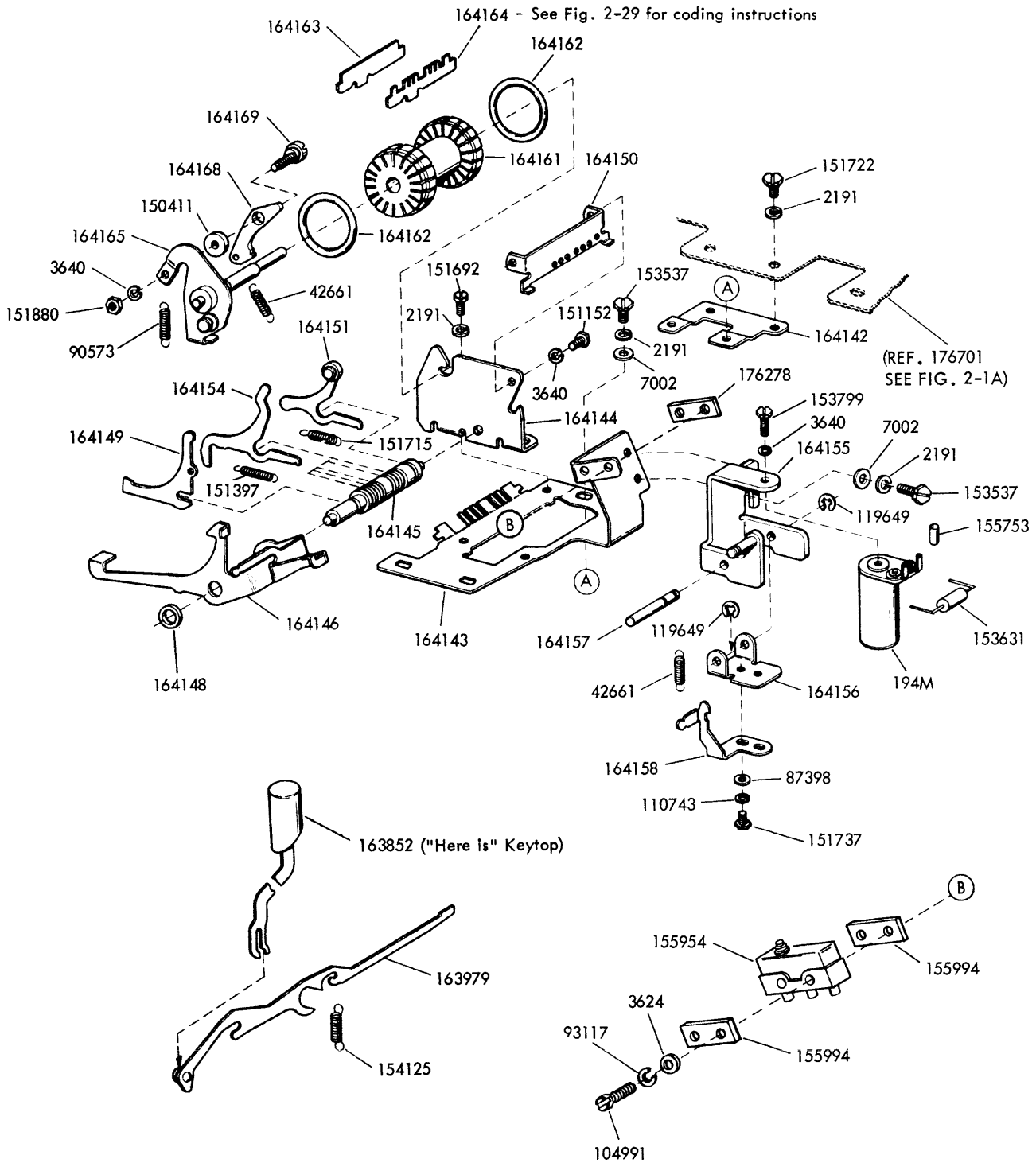
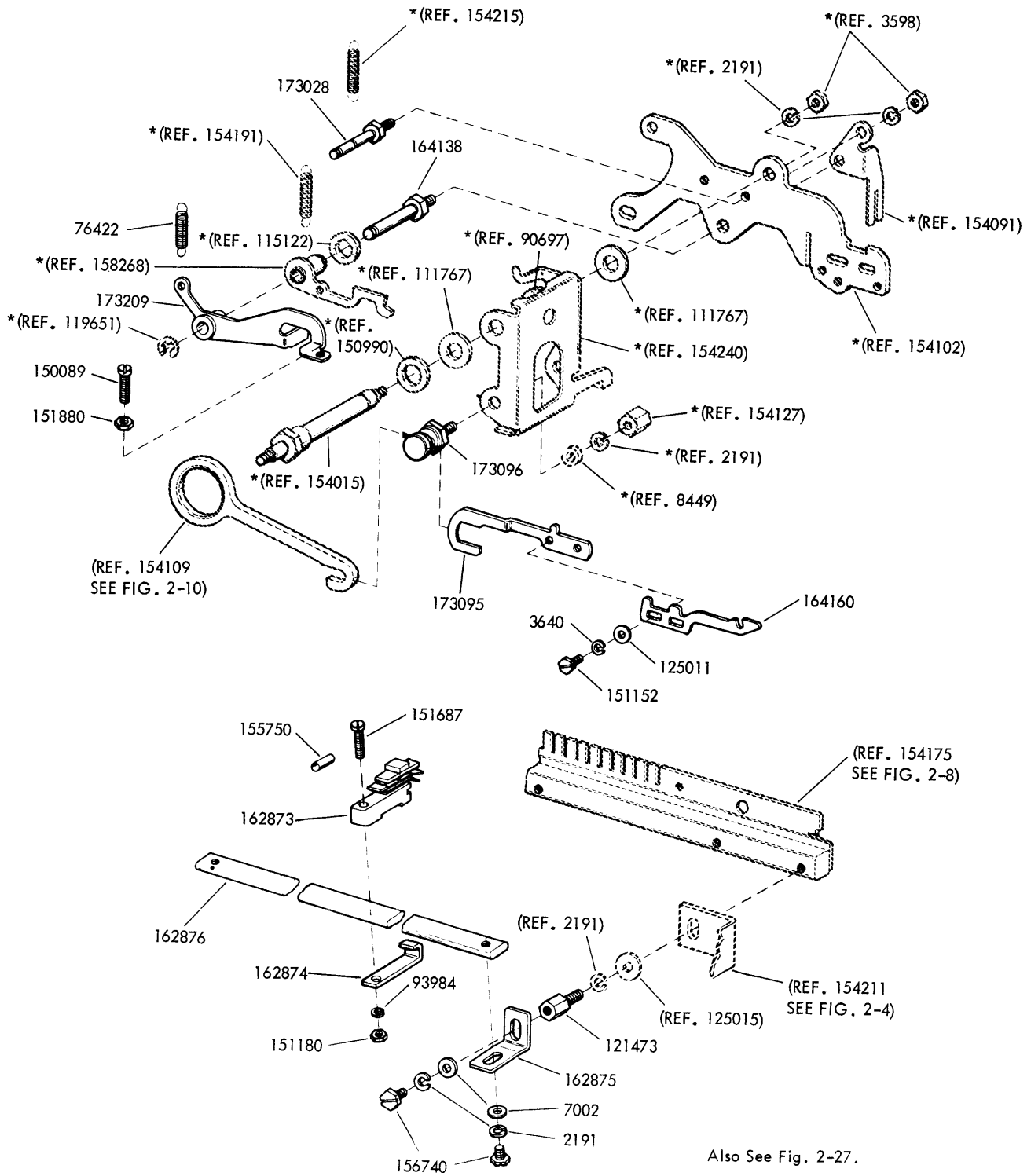


FIGURE 2-26. 174410 CONTACT BOX ASSEMBLY WITH RF SUPPRESSION - POLAR TRANSMISSION



Also See Fig. 2-28

FIGURE 2-27. ANSWER BACK MECHANISM



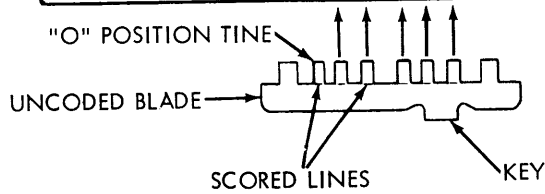
\*These reference parts are shown on Fig. 2-12.

FIGURE 2-28. ANSWER BACK MECHANISM



CHARACTER	CODE				
	1	2	3	4	5
A	X	X			
B	X			X	X
C		X	X	X	
D	X			X	
E	X				
F	X		X	X	
G		X		X	X
H			X		X
I		X	X		
J	X	X		X	
K	X	X	X	X	
L		X			X
M			X	X	X
N			X	X	
O				X	X
P		X	X		X
Q	X	X	X		X
R		X		X	
S	X		X		
T					X
U	X	X	X		
V		X	X	X	X
W	X	X			X
X	X		X	X	X
Y	X		X		X
Z	X				X
CARRIAGE RETURN				X	
LINE FEED		X			
LETTERS SHIFT	X	X	X	X	X
FIGURES SHIFT	X	X		X	X
SPACE			X		
BLANK					

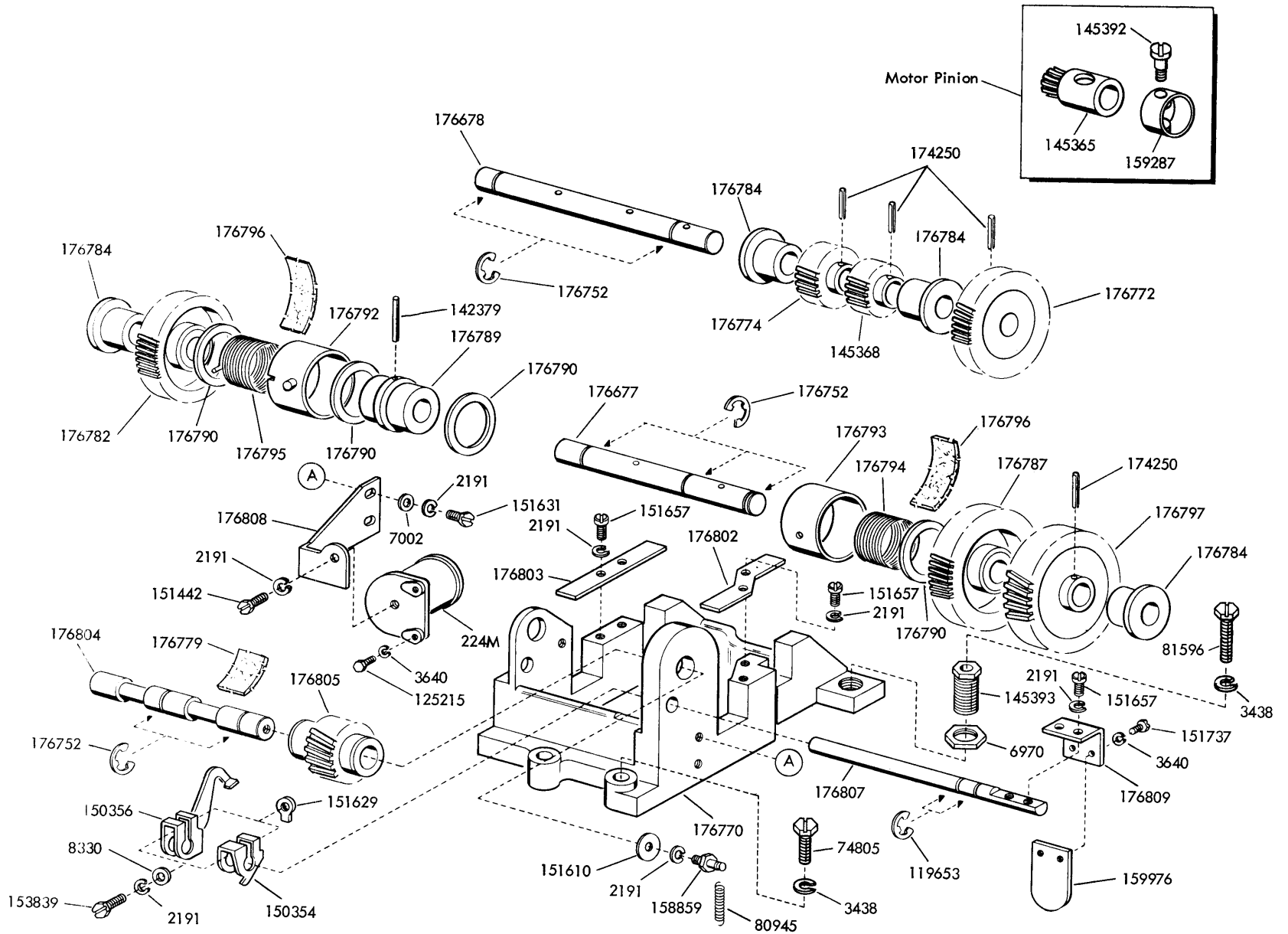
— LEAVE TINE  
 — REMOVE TINE



Coding Instructions for the Code Blades used in the Answer Back Feature on an LK Keyboard Base.

FIGURE 2-29. UNCODED CODE BLADE

FIGURE 2-30. SPEED SHIFT GEAR BRACKET ASSEMBLY



## NUMERICAL INDEX - SECTION 2

Part Number	Description and Page Number	Part Number	Description and Page Number	Part Number	Description and Page Number
194M	Coil, Magnet 2-24	76099	Washer, Flat 2-8, 2-21	119648	Ring, Retaining (Sev.)
224M	Coil, Magnet 2-26	76379	Spring 2-2A	119649	Ring, Retaining (Sev.)
252A	Coil, Magnet 2-20	76422	Spring 2-16,2-25	119650	Ring, Retaining (Sev.)
263M	Coil, Magnet 2-20	78533	Spring 2-11	119651	Ring, Retaining (Sev.)
1020	Screw (6-40 x 1/4 Hex) 2-10	80945	Spring 2-26	119652	Ring, Retaining (Sev.)
1161	Screw (6-40 x 1/4 Fil) 2-14	81596	Screw (10-32 x 1/2 Hex) 2-26	119653	Ring, Retaining (Sev.)
1178	Screw (2-56 x 7/16 Fil) 2-22	81726	Terminal 2-20	119654	Ring, Retaining 2-6
1193	Screw (10-32 x 7/8 Fil) 2-21	81731	Spring 2-18	120175	Plate, Instruction (On-Off) 2-5
1196	Screw (6-40 x 9/32 Fil) 2-14	81774	Washer, Flat 2-4	120824	Washer, Felt 2-9
1210	Screw (2-56 x 5/8 Fil) 2-2	82547	Insulator 2-2A,2-20	120870	Wick, Felt 2-10
1257	Screw (10-32 x 1-1/8 Fil) 2-21	82548	Insulator 2-2A,2-20	121125	Washer, Spring 2-20
1293	Screw (4-40 x 1/8 Fil) 2-12,2-13, 2-23	82860	Spring 2-17	121242	Clamp, Cable (1/8 ID) 2-2,2-15
2191	Washer, Lock (Sev.)	83913	Spring, Contact 2-20	121243	Clamp, Cable (3/16 ID) 2-5
2382	Washer, Lock 2-14	86304	Spring 2-12,2-13	121244	Clamp, Cable (1/4 ID) 2-5
2415	Spring 2-6	86742	Nut (4-40 Hex) 2-11	121245	Clamp, Cable (5/16 ID) 2-2,2-22
2449	Washer, Lock 2-21	86959	Bushing 2-20	121473	Post 2-19,2-25
2481	Washer, Flat 2-20	87398	Spring 2-24	121575	Screw (10-32 x 5/16 Hex) 2-21
2669	Washer, Lock (Sev.)	88891	Spring, Armature 2-20	124177	Washer, Lock 2-21
3339	Nut (9/16-32 Hex) 2-14	90573	Spring 2-24	124244	Washer, Felt 2-2A
3340	Washer, Lock 2-14	90679	Washer, Felt 2-11	125011	Washer, Flat (Sev.)
3438	Washer, Flat 2-2,2-2A,2-3,2-25, 2-26	90791	Washer, Lock 2-12,2-13,2-23	125015	Washer, Flat (Sev.)
3598	Nut (6-40 Hex) (Sev.)	90951	Washer, Lock 2-22	125112	Screw (2-55 x 1/8 Fil) 2-2A
3599	Nut (4-40 Hex) (Sev.)	91231	Terminal 2-13	125126	Screw (2-56 x 9/32 Fil) 2-12,2-13, 2-23
3606	Nut (6-40 Hex) 2-11,2-16,2-21	92265	Screw (2-56 x 1/8 Rd) 2-21	125181	Screw (2-56 x 3/8 Fil) 2-15
3624	Washer, Flat 2-24	92626	Stud 2-18	125231	Nut (10-32 Hex) 2-14,2-21
3640	Washer, Lock 2-2,2-2A,2-7,2-12, 2-13,2-16,2-20,2-23,2-24,2-25, 2-26	93107	Bearing, Ball 2-21	130499	Bearing, Ball 2-21
3870	Spring 2-2,2-6,2-8	93117	Washer, Lock 2-24	130683	Washer, Lock 2-19
4702	Spring 2-8	93118	Washer, Lock 2-2	131099	Terminal 2-12
6807	Screw, Set (6-40) 2-14	93356	Washer, Felt 2-21	139752	Screw (4-40 x 11/64 Fil) 2-7
6970	Nut (3/8-32 Hex) 2-26	93507	Screw (4-40 x 3/4 Hex) 2-2A	139754	Screw, Shoulder (6-40) 2-16
7002	Washer, Flat (Sev.)	93634	Wick, Felt 2-14	142379	Pin, Roll 2-26
8330	Washer, Flat 2-3,2-4,2-14,2-26	93638	Bracket 2-14	144871	Shaft 2-2A
8449	Collar 2-11,2-21	93639	Latch w/Post 2-14	145307	Plate, Nut 2-2A
31636	Spring 2-21	93644	Shaft w/Hub 2-14	145365	Gear (20T) 2-26
33038	Spring 2-14	93645	Flange w/Pin 2-14	145368	Gear (27T) 2-2A
34432	Washer, Flat 2-21	93647	Hub 2-14	145392	Post 2-26
41720	Spring, Contact 2-20	93648	Flange 2-14	145393	Bushing 2-26
41732	Plate, Clamp 2-20	93649	Knob 2-14	146313	Wheel 2-14
42661	Spring 2-24	93705	Cylinder (8-1/2") 2-14	146314	Belt 2-14
42823	Washer, Flat 2-9	93758	Washer, Felt 2-17,2-18	150013	Disk, Adjusting 2-9
45104	Spring 2-22	93984	Washer, Lock 2-24	150026	Lever, Shoe 2-9
45815	Washer, Lock 2-14	94072	Bushing 2-3	150029	Wick, Felt 2-9
49420	Spring 2-3,2-6,2-15,2-20	96646	Screw (6-40 x 1-3/64 Fil) 2-15	150043	Shoe, Clutch 2-9
49653	Screw (10-32 x 13/16 Fil) 2-3	97296	Screw (10-32 x 5/16 Rd) 2-21	150044	Shoe, Clutch 2-9
55090	Spring 2-14	98712	Screw (4-40 x 1/4 Flat) 2-14	150089	Screw (4-40 x 1/2 Fil) 2-21,2-25
55669	Spring 2-2	101386	Spring 2-22	150241	Spring 2-9
70388	Spring 2-10	102057	Screw, Shoulder (4-40) 2-2	150411	Washer, Flat 2-24
71073	Washer, Flat 2-22	104710	Bearing, Ball 2-7	150536	Spring 2-26
71659	Screw, Shoulder (6-40) 2-21	104827	Bearing, Ball 2-3	150923	Washer, Felt 2-2A,2-10,2-11
73008	Washer, Flat 2-11	104991	Screw (2-56 x 1/2 Fil) 2-24	150932	Bushing, Shoulder 2-18
73035	Spring 2-17	108102	Screw (4-40 x 1/4 Flat) 2-5	150966	Insulator 2-2
73705	Block, Terminal 2-14	108103	Washer, Flat 2-21	150990	Washer, Felt 2-11
74554	Post, Spring 2-14	108370	Washer, Felt 2-10	150991	Washer, Felt 2-6, 2-8
74694	Arm 2-14	110437	Spring 2-6	151036	Screw, Shoulder (4-40) 2-11
74695	Sleeve, Clutch 2-14	110743	Washer, Lock (Sev.)	151045	Bar, Space 2-4
74755	Washer, Felt 2-8	111017	Screw (6-40 x 5/16 Fil) 2-2,2-2A	151059	Stud 2-15
74805	Screw (10-32 x 3/4 Hex) 2-3,2-8, 2-26	111343	Clamp 2-7	151073	Screw (4-40 x 5/32 Fil) 2-20
74807	Nut (10-32 Hex) 2-21	111516	Washer, Flat 2-14	151080	Washer, Spacing 2-7
74962	Spring 2-15	111767	Washer, Flat 2-11	151113	Strip 2-2
75607	Washer, Flat 2-21	112127	Retainer 2-2A	151118	Plate, Spacing 2-2
76081	Washer, Flat 2-6	112128	Plate, Retainer 2-2A	151126	Spacer 2-3
76084	Washer, Felt 2-14	112626	Nut (10-32 Hex) 2-3,2-8	151146	Strap, Mounting 2-2
76085	Disk, Friction 2-14	112630	Spring 2-2	151152	Screw (4-40 x 3/16 Hex) 2-7,2-8, 2-12,2-13,2-16,2-23,2-24,2-25
76086	Spring 2-14	114125	Screw (6-40 x 3/8 Hex) 2-21	151171	Toggle 2-12,2-13,2-23
76087	Nut, Friction 2-14	115122	Washer, Felt 2-8,2-11	151180	Link 2-12,2-13,2-17
		116959	Screw, Eccentric 2-21	151182	Washer, Insulating 2-12,2-13,2-23
		117416	Stud 2-8	151223	Screw, Shoulder (4-40) 2-4
		117535	Washer, Flat 2-14	151224	Screw, Pilot (6-40) 2-2A,2-4
		117608	Nut, Speed 2-4		
		119535	Bushing 2-14		

## NUMERICAL INDEX - SECTION 2 (Continued)

Part Number	Description and Page Number	Part Number	Description and Page Number	Part Number	Description and Page Number
151228	Bracket 2-3	152463	Latch 2-2	154066	Lever 2-3
151234	Ratchet 2-22	152464	Insulator 2-2	154067	Lever 2-3
151235	Ratchet 2-22	152467	Connector, Plug (20 Pt) 2-2,2-12, 2-13,2-23	154068	Bracket, Right 2-6
151236	Hub 2-22			154069	Bracket, Left 2-6
151237	Spring 2-22	152754	Jumper 2-2A	154070	Guide 2-6
151240	Pawl, Latch 2-22	152893	Screw (4-40 x 1/4 Hex) 2-7	154071	Screw, Pilot (1/4-32) 2-6
151241	Lever, Latch 2-22	153247	Lever 2-18	154072	Bracket 2-6
151244	Bushing, Eccentric 2-22	153248	Bushing, Shoulder 2-17,2-18	154076	Plate 2-2
151245	Washer, Felt 2-22	153249	Bail, Transfer 2-18	154079	Stud 2-11
151246	Shim (.020") 2-22	153250	Link 2-18	154080	Lock, Wedge 2-6
151290	Keylever Assembly 2-15	153252	Link 2-2	154081	Retainer, Ball 2-7
151329	Switch 2-15,2-22	153266	Lever 2-17	154083	Spacer 2-9
151335	Stud 2-2,2-2A	153273	Link 2-17	154084	Bearing, Needle 2-11
151346	Screw (6-40 x 3/8 Fil) 2-21	153283	Keylever Assembly 2-18	154085	Plate 2-2
151352	Spring 2-2	153284	Keylever Assembly 2-17	154086	Retainer, Wedge 2-6, 2-7
151376	Label 2-4	153442	Screw (10-32 x 1/2 Hex) 2-14	154087	Plate 2-2
151389	Paper, Carbon 2-4	153537	Screw (6-40 x 9/32 Hex) 2-14,2-24	154088	Plate 2-2
151390	Label 2-4	153538	Screw (6-40 x 7/16 Hex) 2-14	154089	Post 2-11
151391	Label Set 2-4	153817	Screw (4-40 x 3/8 Hex) 2-2	154091	Guide 2-11
151397	Spring 2-24	153839	Screw (6-40 x 5/8 Hex) 2-26	154092	Shaft 2-3
151412	Insulator 2-2A	153841	Screw (6-40 x 9/16 Hex) 2-8,2-15	154095	Eccentric 2-12,2-13
151415	Block, Terminal 2-2	154000	Base 2-2	154096	Bushing 2-8
151416	Nut (6-40 Hex) 2-2,2-2A	154001	Bar, Code (#1) 2-6	154097	Lever 2-17
151442	Screw (6-40 x 1/2 Hex) 2-4,2-8,2-14, 2-26	154002	Bar, Code (#2) 2-6	154098	Bail 2-17
		154003	Bar, Code (#3) 2-6	154099	Bail 2-3
151610	Washer, Flat 2-26	154004	Bar, Code (#4) 2-6	154101	Plate 2-8
151618	Screw (6-40 x 7/16 Fil) 2-21	154005	Bar, Code (#5) 2-6	154102	Plate 2-11
151626	Terminal 2-2,2-5,2-15	154008	Guide 2-6	154105	Post 2-10
151629	Nut (6-40 Lug) 2-26	154009	Plate 2-10	154106	Bracket 2-2
151630	Screw (6-40 x 1/4 Hex) (Sev.)	154010	Bail 2-10	154107	Bracket 2-17
151631	Screw (6-40 x 5/16 Hex) (Sev.)	154011	Guide 2-10	154109	Plunger 2-2
151632	Screw (6-40 x 3/8 Hex) (Sev.)	154012	Guide 2-10	154110	Hood, Keyboard 2-4
151657	Screw (6-40 x 1/4 Fil) 2-14,2-20, 2-21,2-26	154013	Bracket 2-6	154111	Plate 2-4
		154014	Post 2-10	154112	Lever 2-16
151659	Screw (6-40 x 1/2 Fil) 2-4,2-21	154015	Post 2-11	154114	Post 2-16
151660	Screw (6-40 x 7/8 Fil) 2-14	154016	Shaft 2-6	154115	Plate 2-2
151678	Screw, Pilot (1/4-32) 2-2	154017	Stud 2-11	154116	Bail w/Stud 2-18
151686	Screw (4-40 x 3/8 Fil) 2-12,2-13, 2-16,2-23	154018	Post 2-10	154117	Bail 2-4
		154019	Follower 2-9	154118	Lever 2-15
151687	Screw (4-40 x 1/2 Fil) 2-25	154020	Seal 2-4	154119	Bracket 2-4
151688	Screw (4-40 x 5/8 Fil) 2-16	154021	Link 2-4	154120	Lever 2-6
151692	Screw (6-40 x 3/16 Fil) 2-16,2-18, 2-24	154023	Latch 2-6	154121	Lever 2-6
		154025	Plate, Adjusting 2-11	154122	Lever 2-6
151693	Screw (6-40 x 9/16 Fil) 2-21	154027	Bellcrank 2-11	154123	Lever 2-6
151694	Screw (6-40 x 11/32 Fil) 2-2	154029	Wick, Felt 2-9	154124	Lever 2-6
151712	Button, Pivot 2-3	154030	Shaft 2-9	154125	Spring 2-6, 2-19,2-24
151715	Spring 2-24	154032	Sleeve, Gear 2-9	154126	Bracket 2-15
151722	Screw (6-40 x 3/16 Hex) 2-2,2-4, 2-6,2-10,2-17,2-21,2-22,2-24	154033	Lever 2-8	154127	Nut (6-40 Hex) 2-11
		154034	Lever 2-8	154129	Bar 2-6
151723	Screw (10-32 x 3/8 Hex) 2-2A,2-14	154036	Plate 2-10	154130	Box, Contact 2-12
151724	Screw (10-32 x 5/8 Hex) 2-3	154037	Lever 2-15	154131	Cover 2-12,2-13
151725	Screw (10-32 x 3/4 Fil) 2-3	154039	Bracket 2-15	154132	Bracket 2-18
151728	Spring 2-9	154040	Post 2-10	154133	Bracket 2-17
151731	Screw (4-40 x 7/8 Fil) 2-12,2-13	154041	Post 2-10	154134	Bracket 2-22
151732	Screw (4-40 x 11/32 Fil) 2-19,2-21	154042	Terminal 2-12,2-13,2-23	154135	Pawl, Contact 2-22
151733	Screw (4-40 x 9/16 Fil) 2-20	154043	Terminal 2-12,2-13,2-23	154136	Pawl 2-22
151737	Screw (4-40 x 11/64 Hex) 2-9,2-24, 2-26	154045	Screw, Contact (4-40) 2-12,2-13, 2-23	154137	Lever, Adjusting 2-22
		154046	Stud 2-8	154138	Washer, Felt 2-9
151820	Spring 2-12,2-13,2-23	154047	Post 2-10	154140	Bail 2-10
151843	Screw, Adjusting (6-40) 2-7	154051	Screw, Shoulder (6-40) 2-11	154141	Modification Kit 2-15
151879	Stud 2-22	154052	Bar 2-6	154142	Modification Kit 2-22
151880	Nut (4-40 Hex) 2-12,2-13,2-23, 2-25	154053	Bail 2-8	154144	Cable Assembly 2-22
		154055	Bracket 2-6	154145	Modification Kit 2-18
151885	Plate, Nut 2-22	154056	Bracket 2-12,2-13,2-23	154146	Modification Kit 2-17
151886	Stud 2-22	154057	Plate 2-4	154147	Modification Kit 2-15
152045	Guard, Gear 2-2	154058	Plate 2-4	154149	Cable Assembly 2-15
152051	Tissue 2-4	154059	Bracket 2-3	154153	Cable Assembly 2-15
152318	Switch 2-15	154064	Bracket 2-17	154154	Cam 2-9
152441	Washer, Flat 2-21	154065	Lever 2-17	154156	Grommet 2-12
152462	Latch 2-2			154165	Box Assembly, Contact 2-12

## NUMERICAL INDEX - SECTION 2 (Continued)

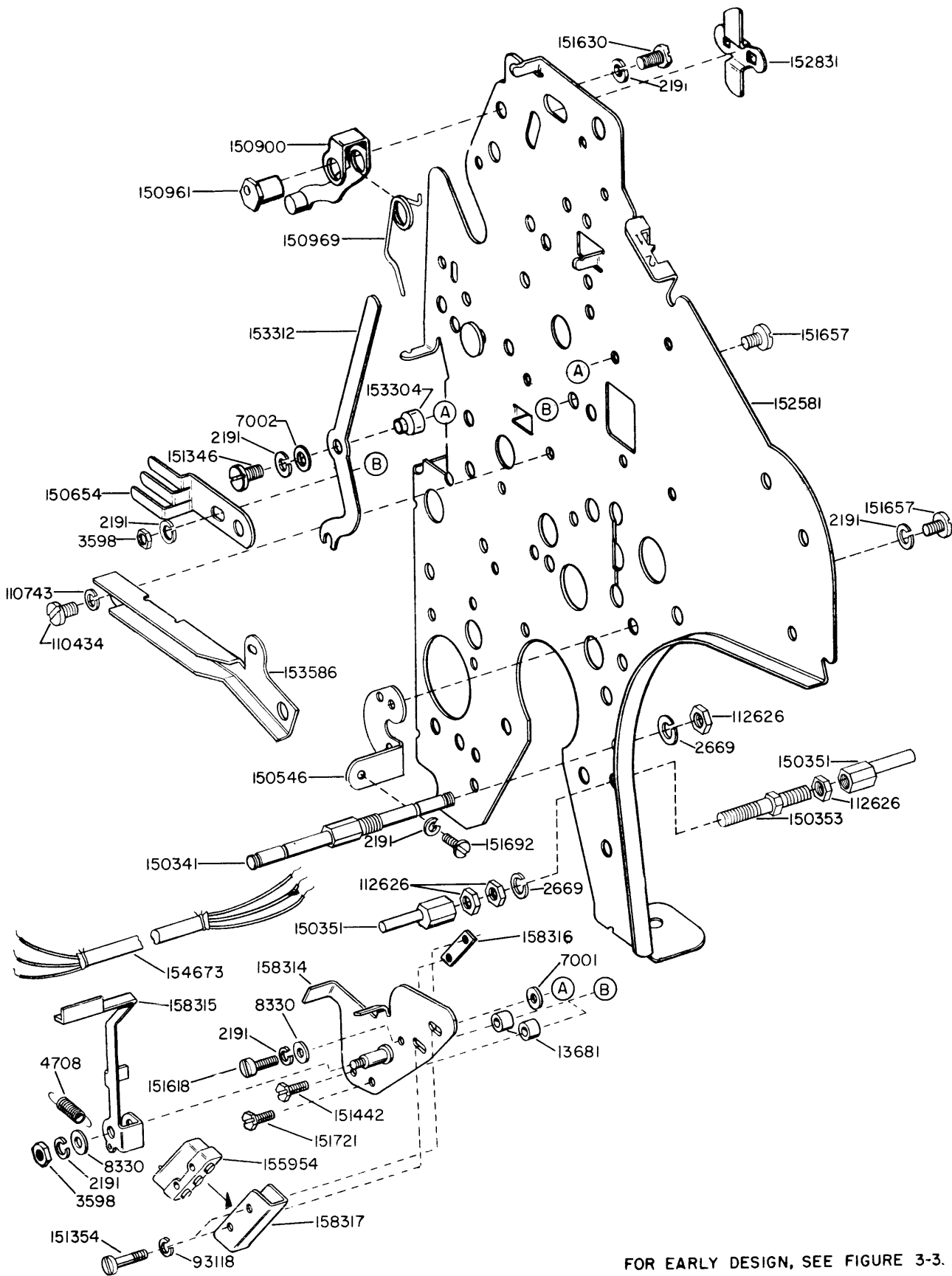
Part Number	Description and Page Number	Part Number	Description and Page Number	Part Number	Description and Page Number
154166	Suppressor, Arc 2-12	158732	Gear (24T and 18T) 2-21	163775	Modification Kit 2-16
154172	Cable Assembly 2-12	158733	Gear (44T) 2-21	163813	Plate w/Stud 2-16
154173	Plate 2-12	158734	Gear (47T) 2-21	163814	Lever w/Hub 2-16
154175	Channel, Lock Ball 2-7	158740	Block 2-21	163816	Switch (Red) 2-5
154176	Bracket 2-2	158741	Bar 2-21	163817	Switch (Black) 2-5
154178	Spring 2-10	158753	Armature 2-20	163852	Keylever Assembly 2-24
154179	Bail 2-7	158754	Core, Magnet 2-20	163963	Plate 2-5
154183	Blade, Front 2-7	158788	Clamp, Bearing 2-21	163964	Plate 2-5
154184	Blade, Rear 2-7	158859	Post 2-20,2-26	163979	Lever w/Stud 2-19,2-26
154189	Insulator 2-12,2-13	159287	Isolator 2-26	164005	Modification Kit 2-19
154190	Filter w/Terminals 2-13	159976	Armature 2-26	164078	Washer, Flat 2-19
154191	Spring 2-11	161100	Spring, Contact 2-2A	164127	Plate 2-5
154193	Plate 2-15	161346	Washer, Felt 2-10	164131	Cable Assembly 2-5
154194	Base 2-12,2-13,2-23	161347	Washer, Felt 2-16, 2-22	164138	Stud 2-25
154197	Plug, Button 2-4	161525	Connector, Plug (14 Pt) 2-5	164143	Plate, Mounting 2-24
154198	Window 2-4	162337	Strap 2-13	164144	Plate, Side 2-24
154199	Shim (.005") 2-2	162436	Cable Assembly 2-13	164145	Pivot 2-24
154200	Frame 2-8	162437	Cable Assembly 2-13	164146	Lever, Stop 2-24
154201	Shim (.014") 2-2	162641	Modification Kit 2-21	164148	Spacer 2-24
154202	Screw, Special 2-4,2-5	162643	Bracket 2-21	164149	Lever, Blocking 2-24
154203	Bracket 2-4	162645	Gear (21T) 2-21	164150	Bracket, Spring 2-24
154204	Grommet 2-4, 2-5	162646	Shaft 2-21	164154	Lever, Sensing 2-24
154206	Cable Assembly 2-12,2-13	162647	Sleeve 2-21	164155	Yoke, Magnet 2-24
154207	Cable Assembly 2-12	162648	Plate 2-21	164156	Armature 2-24
154208	Bracket 2-2	162649	Retainer 2-21	164157	Shaft 2-24
154209	Box, Contact 2-13	162650	Shaft W/Bearing 2-21	164160	Link, Drive 2-25
154210	Bracket 2-4	162652	Plate 2-21	164161	Drum, Message 2-24
154211	Bracket 2-4	162653	Retainer 2-21	164162	Ring, Retainer 2-24
154212	Frame 2-4	162654	Hub 2-21	164163	Blade, Stop 2-24
154215	Spring 2-11	162655	Gear (42T) 2-21	164164	Blade, Code 2-24
154217	Wick 2-10	162656	Shaft 2-21	164165	Plate, Drive 2-24
154225	Box Assembly, Contact 2-13	162657	Gear (48T) 2-21	164168	Pawl, Stepping 2-24
154226	Box w/Strap 2-13	162658	Hub 2-21	164169	Stud, Eccentric 2-24
154227	Bracket 2-17	162659	Retainer 2-21	164201	Switch (Gray) 2-5
154236	Lever 2-8	162660	Post 2-21	164269	Plate 2-5
154237	Lever 2-11	162661	Link w/Stud 2-21	164327	Cable Assembly 2-5
154238	Extension 2-7	162663	Stud 2-21	164375	Plate 2-5
154239	Extension w/Post 2-7	162664	Link 2-21	164376	Guard 2-5
154240	Bail 2-11	162665	Bracket 2-21	164379	Cable Assembly 2-20
154241	Stud 2-11	162666	Lever w/Stud 2-21	164485	Bail w/Hub 2-20
154330	Plate 2-11	162668	Bracket 2-21	164494	Modification Kit 2-15
154350	Modification Kit 2-11	162669	Gear (15T) 2-21	164495	Cable Assembly 2-15
154386	Plate, Adjusting 2-11	162686	Guard 2-21	164617	Base 2-14
154662	Spacer 2-3	162873	Contact Assembly, Universal 2-19, 2-25	164644	Post 2-20
154663	Shaft 2-3			164645	Post 2-20
154694	Disk 2-9	162874	Clamp 2-19,2-25	164646	Plate, Nut 2-20
155023	Switch, Toggle 2-5	162875	Bracket 2-19,2-25	164647	Bracket 2-20
155750	Sleeve, Insulating 2-2,2-12,2-13, 2-20,2-22, 2-23,2-25	162876	Bar 2-19,2-26	164649	Plate 2-20
		162878	Contact Assembly 2-2A	164650	Contact Assembly 2-20
155751	Sleeve, Insulating 2-15,2-22	162879	Spring, Contact 2-2A	164651	Bail, Armature 2-20
155753	Sleeve, Insulating 2-13,2-24	162880	Bracket 2-2A	164652	Bar, Universal 2-20
155944	Post 2-24	162881	Plate 2-2A	164653	Bracket 2-20
155954	Switch 2-24	162882	Bushing 2-2A	164656	Bar, Clutch Trip 2-20
156503	Wick, Felt 2-9	162883	Guard, Contact 2-2A	164660	Modification Kit 2-20
156509	Washer, Flat 2-10	162884	Arm 2-2A	164718	Plate, Adapter 2-14
156516	Latch 2-10	162885	Cam 2-9	164719	Bracket Assembly 2-14
156574	Post 2-7	162886	Screw (4-40 x 7/32 Hex) 2-9	164720	Bracket Assembly 2-14
156591	Washer, Felt 2-14	162891	Cover 2-13	164721	Shaft 2-14
156630	Washer, Felt 2-10	162892	Box Assembly, Contact 2-13	164722	Hub 2-14
156632	Screw (6-40 x 13/32 Hex) 2-4	162893	Cable Assembly 2-13	164723	Wheel 2-14
156644	Link 2-12,2-13,2-23	163359	Modification Kit 2-21	164724	Pulley 2-14
156663	Insulator 2-12,2-13,2-23	163360	Bracket 2-21	164725	Pulley 2-14
156740	Screw (6-40 x 7/32 Hex) 2-2A,2-25	163368	Cam 2-9	164726	Post 2-14
157288	Plate, Adapter 2-21	163440	Gear (48T) 2-3	164727	Lever 2-14
158163	Switch 2-2,2-12,2-13	163445	Insulator 2-13,2-23	164728	Post 2-14
158164	Lever 2-2	163460	Gear (55T) 2-3	164729	Bracket Assembly 2-14
158268	Latch, Code Bar Bail 2-11	163506	Cable Assembly 2-13	164731	Shaft 2-14
158712	Gear (26T) 2-21	163519	Sleeve, Gear 2-9	164732	Shaft 2-14
158716	Gear (39T) 2-21	163536	Screw 2-13	164734	Belt 2-14
158723	Roller 2-21	163537	Screw (4-40 x 1-1/2 Fil)2-13,2-23	164735	Coupling, Flexible 2-14

1149B

NUMERICAL INDEX - SECTION 2 (Continued)

Part Number	Description and Page Number	Part Number	Description and Page Number	Part Number	Description and Page Number
164926	Modification Kit 2-14	174414	Bushing, Insulator 2-23	176782	Gear (63T) 2-26
172635	Plate 2-14	174415	Cover 2-23	176784	Flange, Bearing 2-26
172636	Bracket 2-14	174416	Box, Contact 2-23	176787	Gear (66T) 2-26
172976	Filter w/Terminals 2-13	174421	Filter W/Terminals 2-23	176789	Hub 2-26
173028	Post, Spring 2-25	174422	Filter W/Terminals 2-23	176790	Washer, Bearing 2-26
173029	Lever, Latch 2-25	174491	Modification Kit 2-13	176792	Sleeve 2-26
173095	Link, Drive 2-25	176278	Plate, Nut 2-24	176793	Sleeve 2-26
173096	Stud, Eccentric 2-25	176659	Lever, Trip 2-2A	176794	Spring 2-26
173124	Cable Assembly 2-2	176661	Bracket 2-2A	176795	Spring 2-26
173453	Cable Assembly 2-23	176663	Link 2-2A	176796	Wick, Felt 2-26
173712	Cable Assembly 2-2	176672	Solenoid, Feed Out 2-2A	176797	Gear (48T) 2-26
173907	Spacer 2-21	176673	Suppressor, Spark 2-2A	176799	Gear, (35T) 2-26
173908	Post 2-21	176677	Shaft, Clutch 2-26	176802	Plate, Bearing 2-26
173909	Washer, Locking 2-21	176678	Shaft, Driver 2-26	176803	Plate, Bearing 2-26
173912	Plate Assembly 2-21	176691	Resistor (500 ohms) 2-2A	176804	Shaft, Idler 2-26
174250	Pin, Roll 2-26	176703	Plate, Mounting 2-2A	176805	Gear (25) 2-26
174410	Box Assembly, Contact <u>2-23</u>	176752	Ring Retaining 2-26	176807	Shaft, Trip 2-26
174411	Insulator 2-23	176770	Bracket 2-26	176808	Bracket 2-26
174412	Spacer 2-3	176772	Gear (56T) 2-26	176809	Bracket 2-26
174413	Terminal 2-23	176774	Gear (42T) 2-26	179110	Cable Assembly 2-23

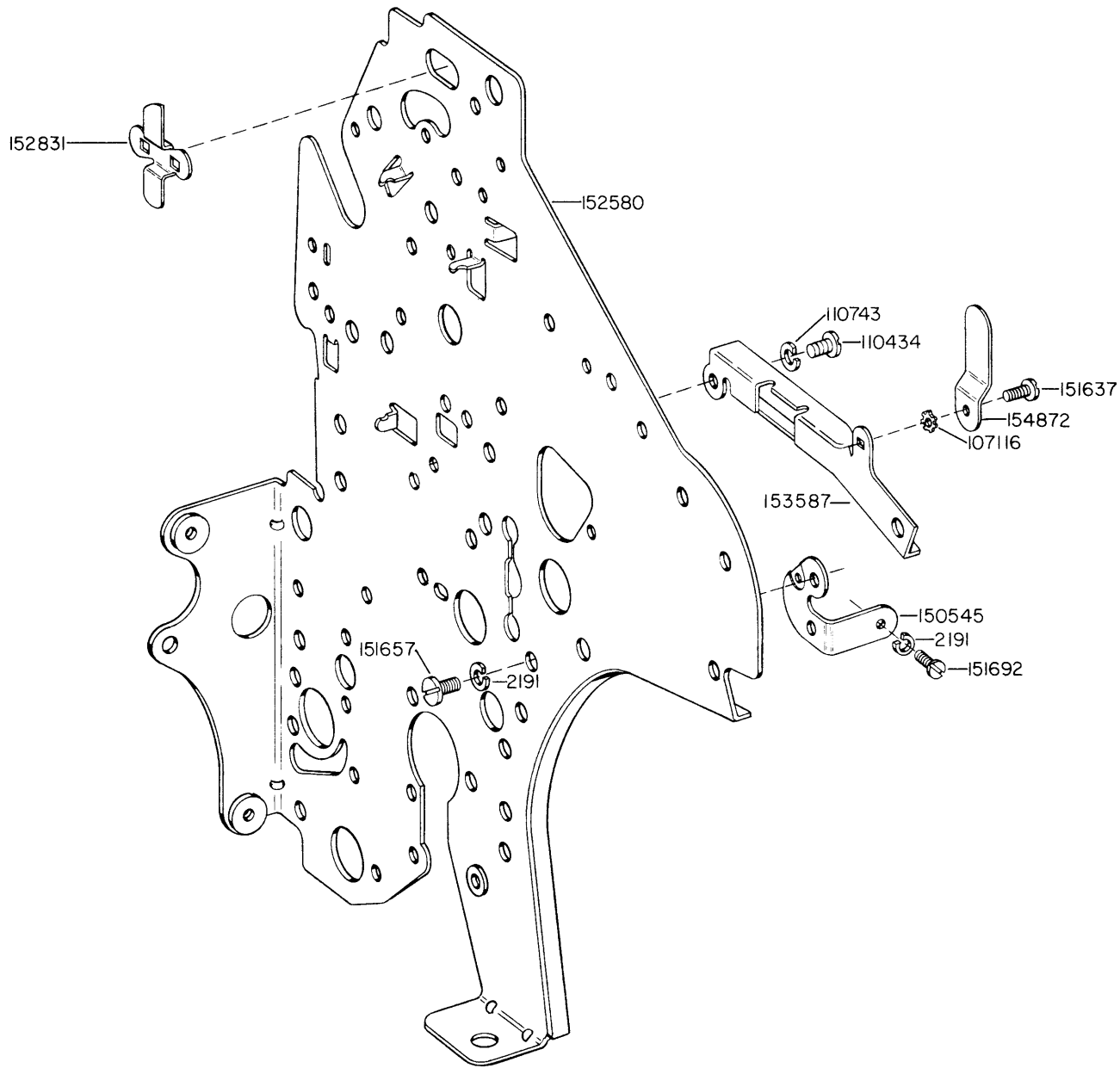
**SECTION 3**  
**TYPING UNIT**



FOR EARLY DESIGN, SEE FIGURE 3-3.

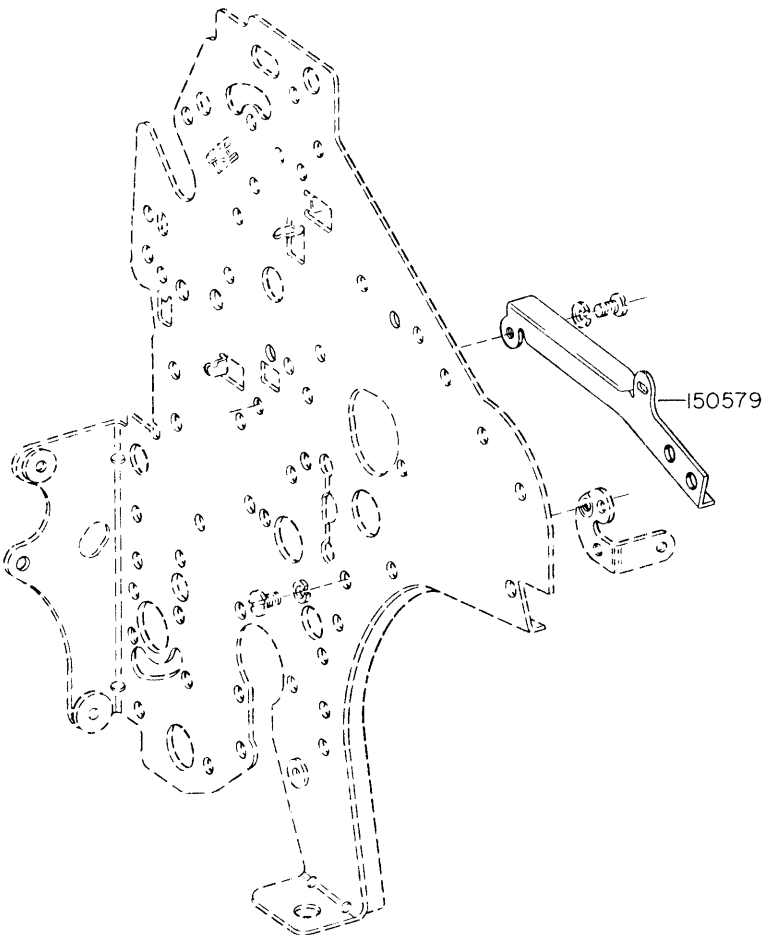
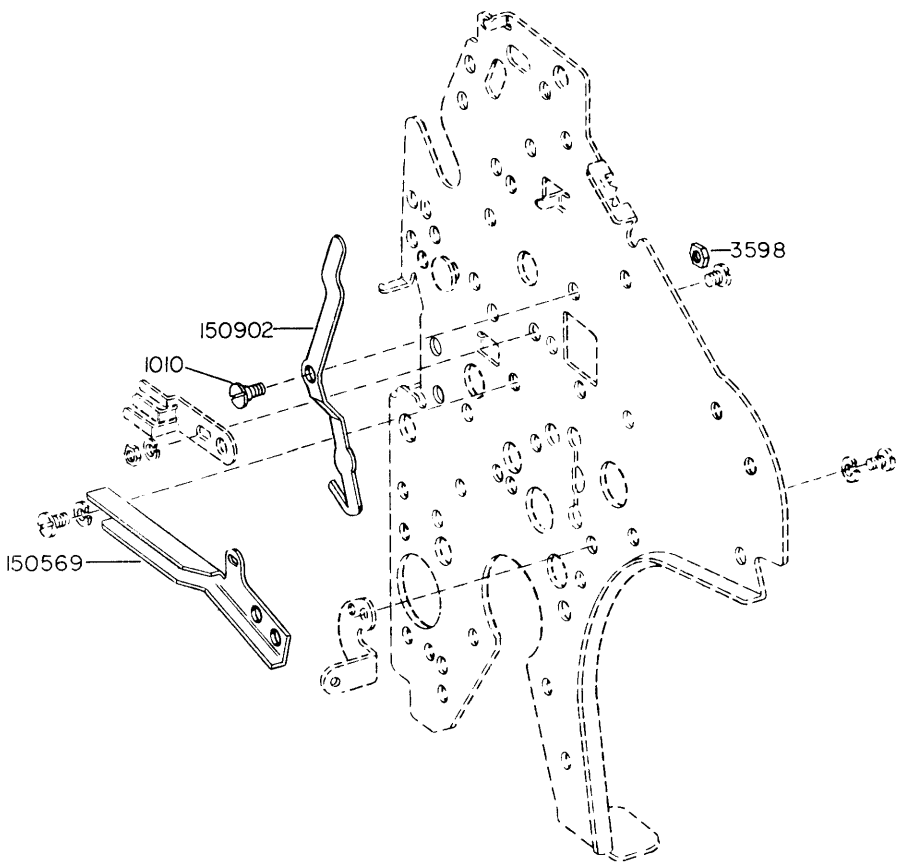
FIGURE 3-1 LEFT SIDE FRAME MECHANISM





FOR EARLY DESIGN, SEE FIGURE 3-3.

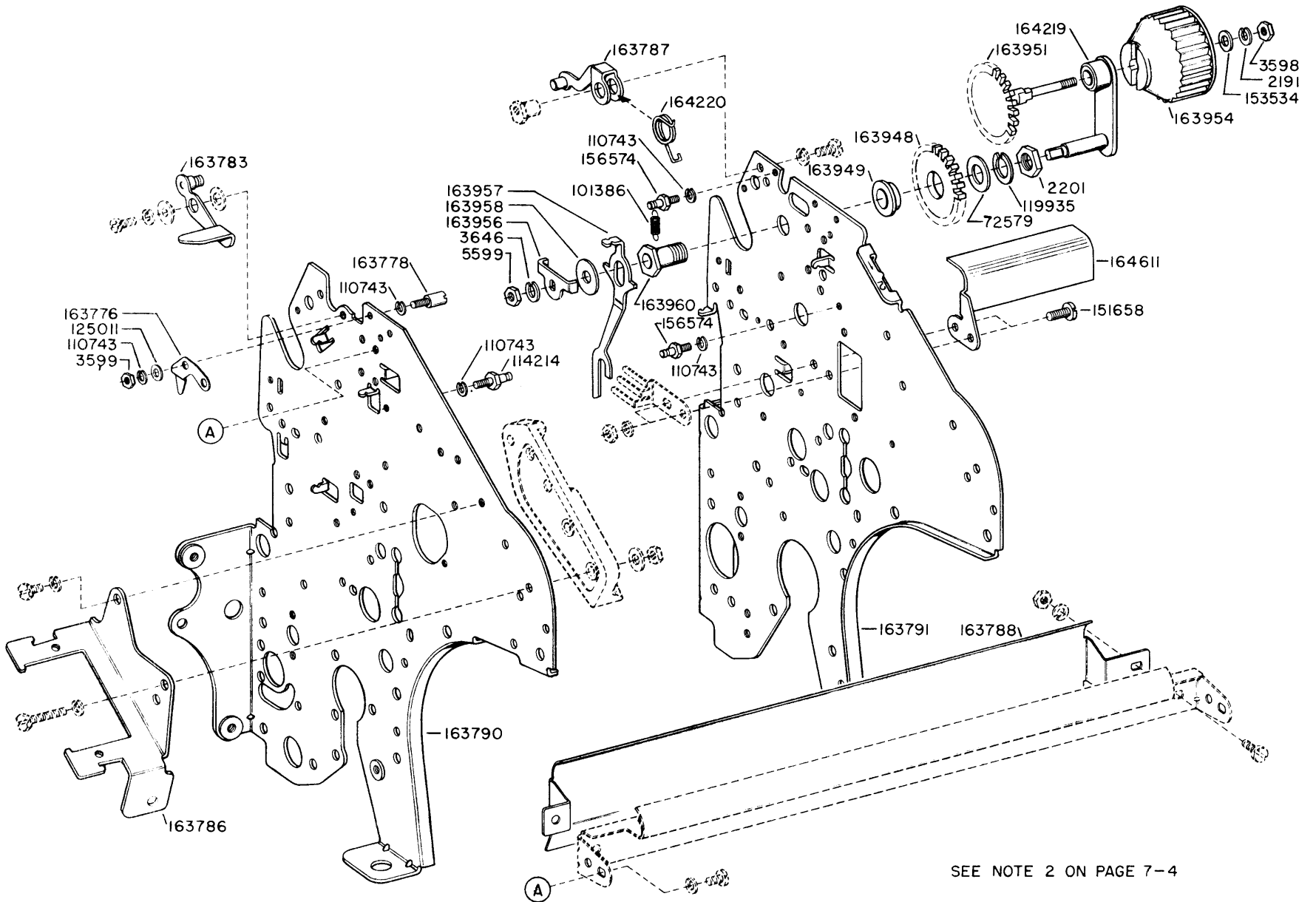
FIGURE 3-2. RIGHT SIDE FRAME MECHANISM



SEE NOTE 1 ON PAGE 7-4  
EARLY DESIGN PARTS

FIGURE 3-3 LEFT AND RIGHT SIDE FRAMES MECHANISM

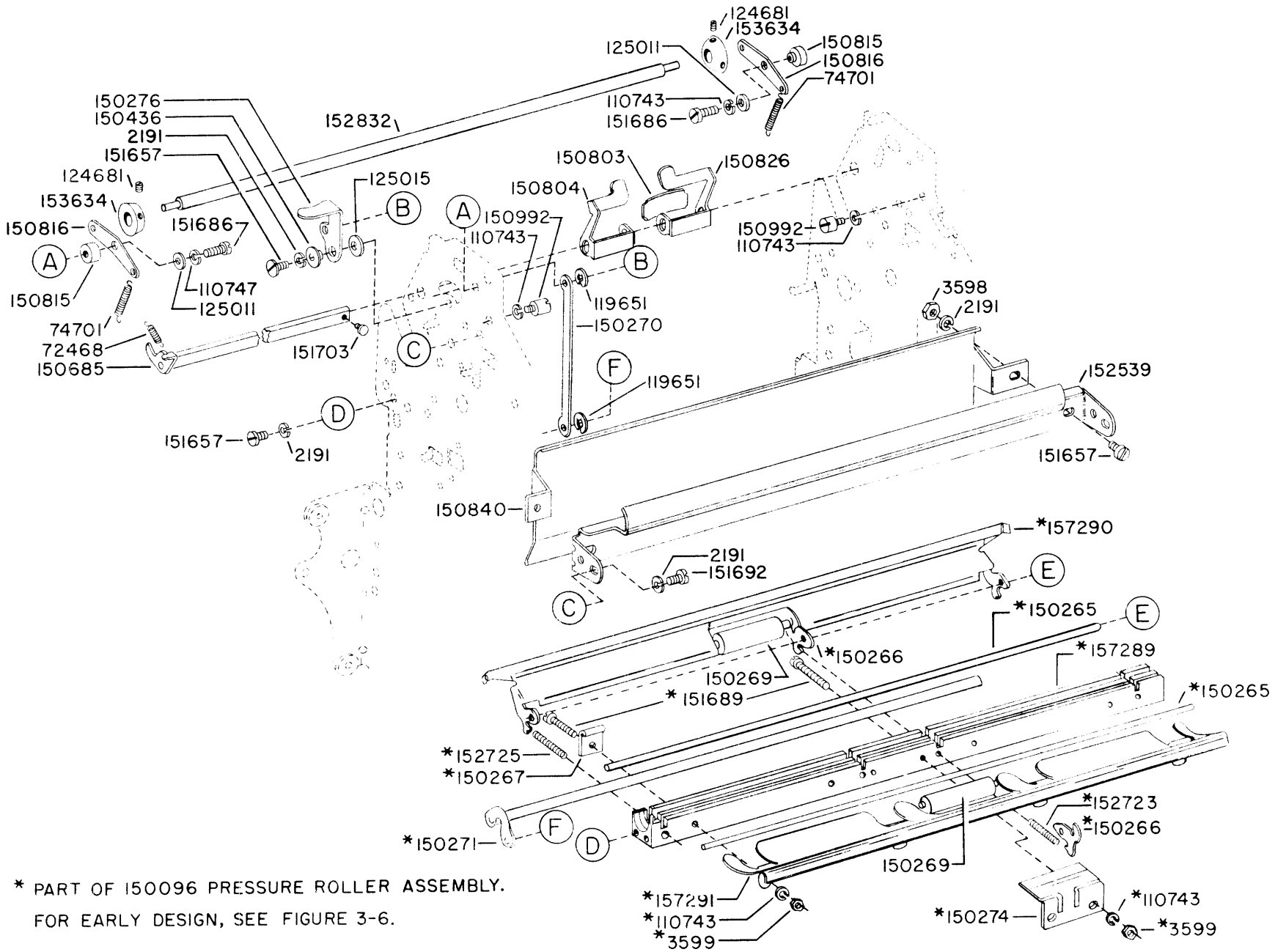
FIGURE 3-4 LEFT AND RIGHT SIDE FRAMES MECHANISM



11498

SEE NOTE 2 ON PAGE 7-4

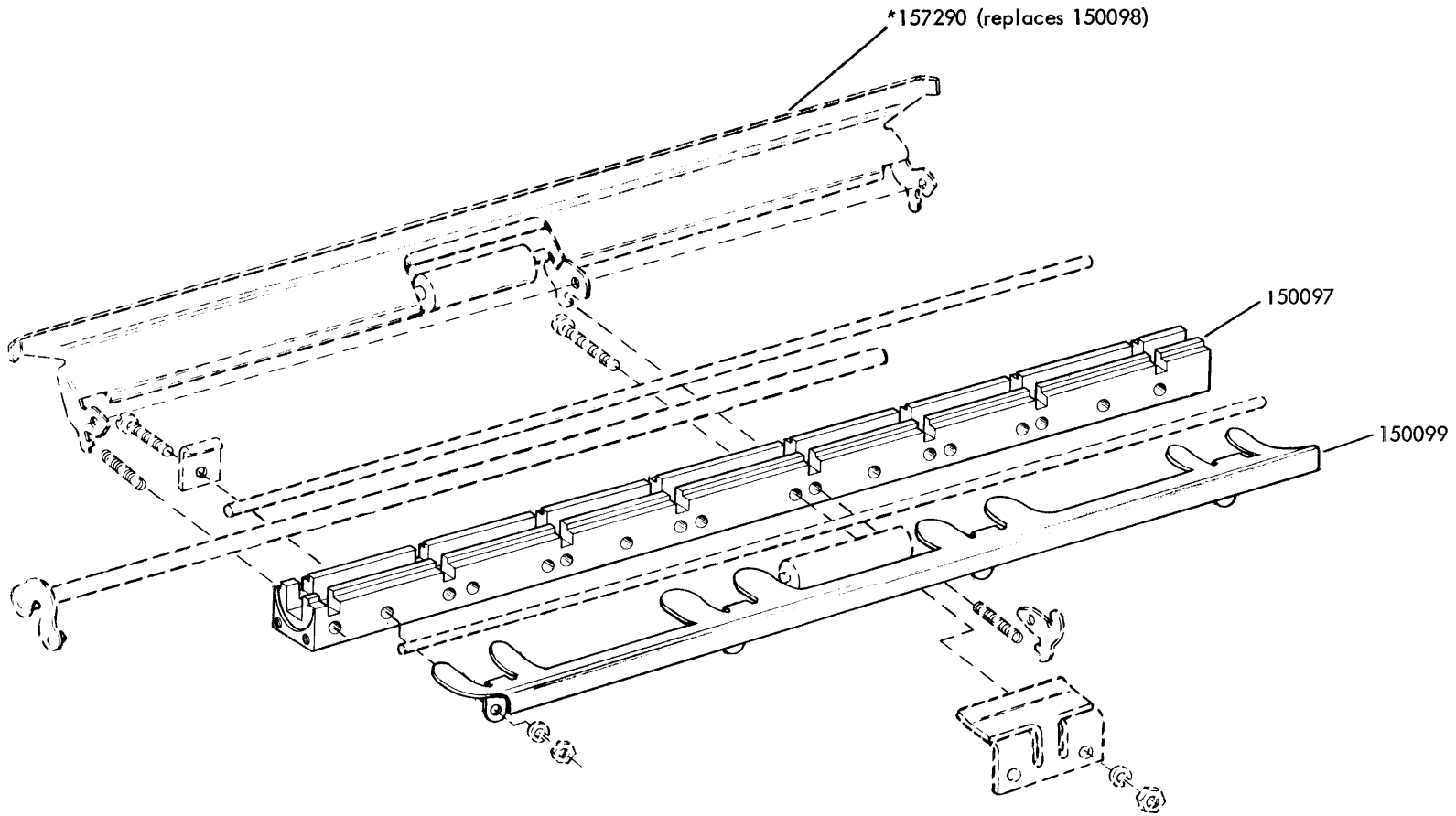
FIGURE 3-5. PRESSURE ROLLER MECHANISM



11498

\* PART OF 150096 PRESSURE ROLLER ASSEMBLY.  
FOR EARLY DESIGN, SEE FIGURE 3-6.

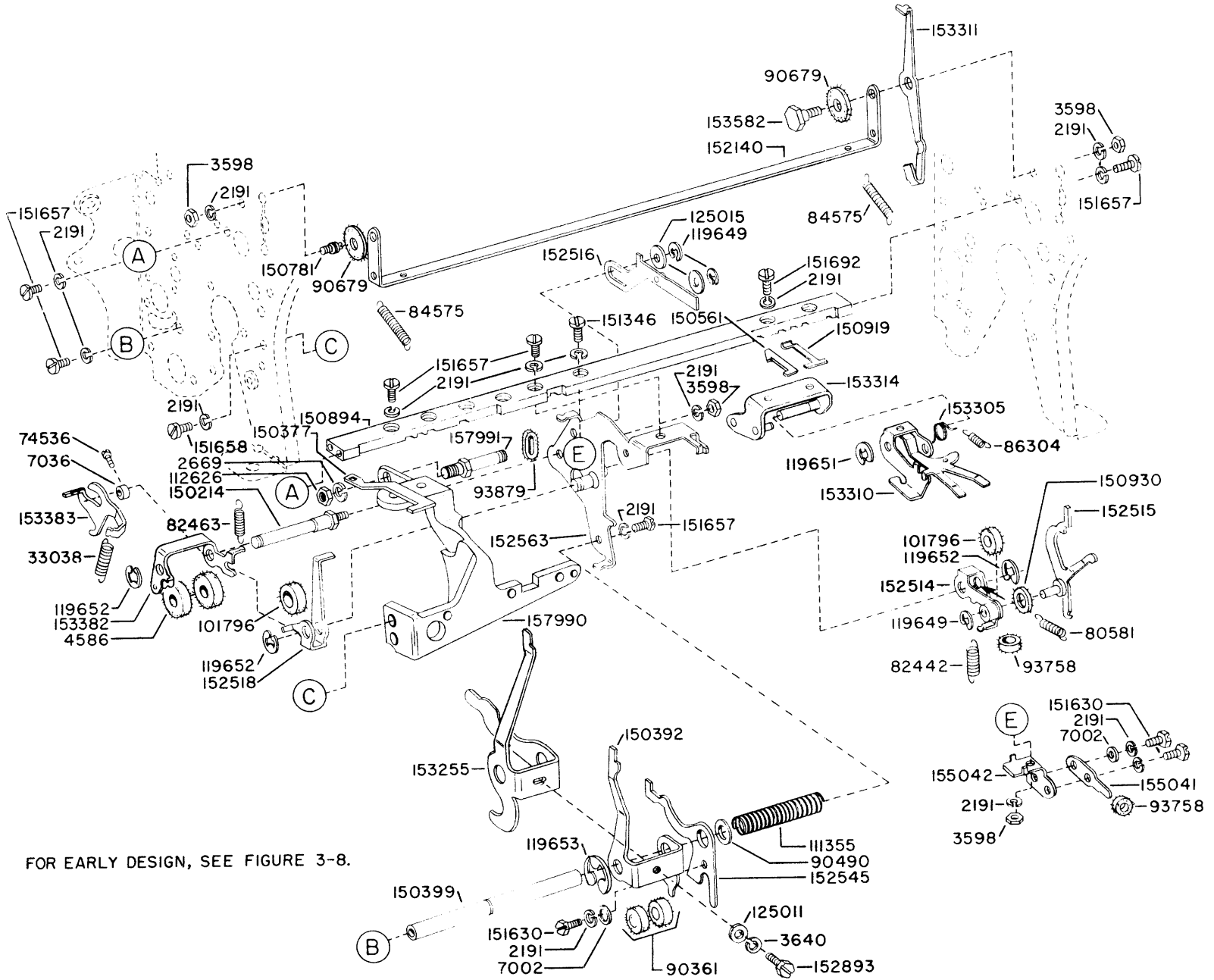
FIGURE 3-6. PRESSURE ROLLER MECHANISM



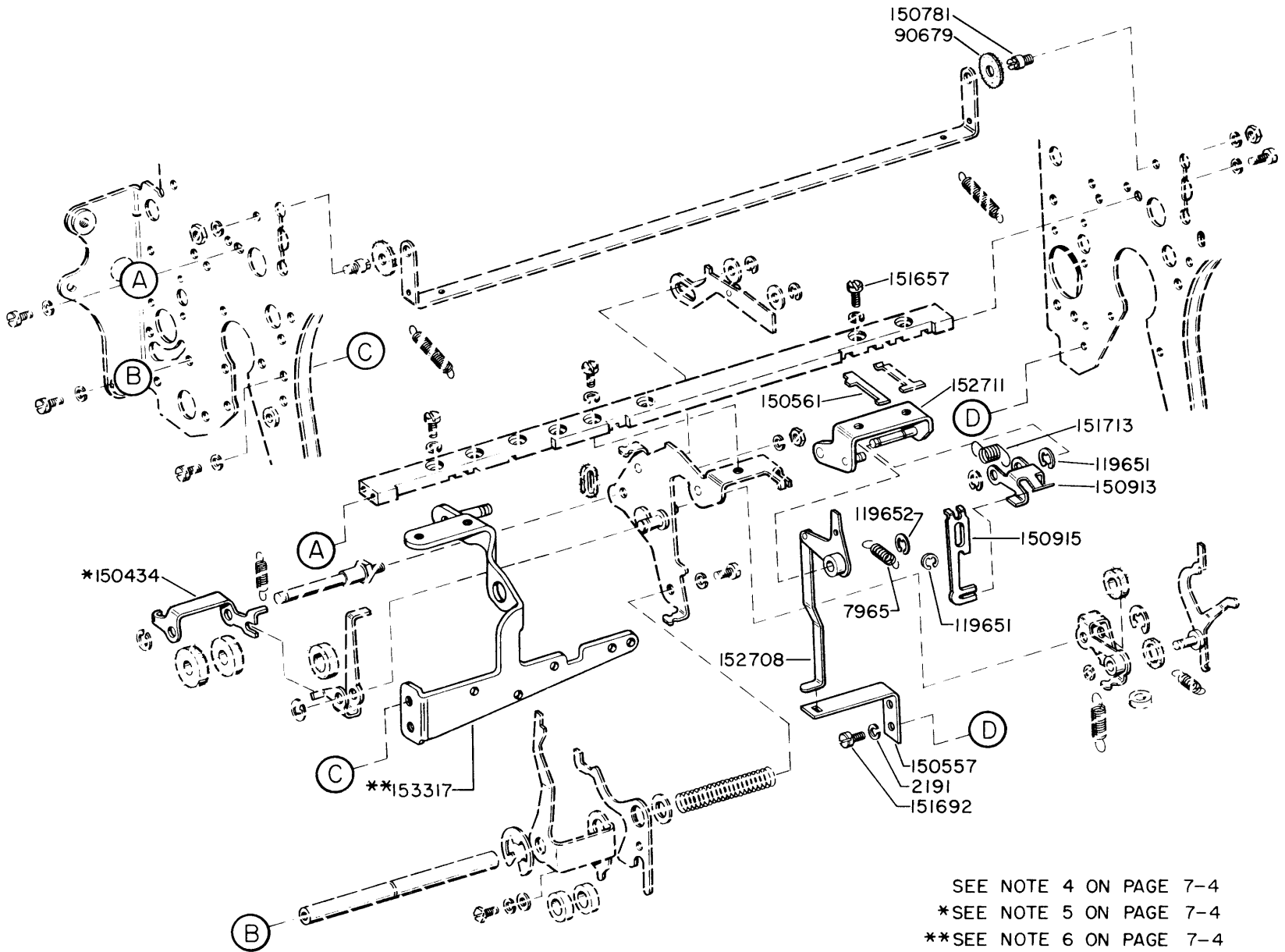
11498

\*SEE NOTE 3 ON PAGE 7-4  
EARLY DESIGN PARTS

FIGURE 3-7. SPACE SUPPRESSION MECHANISM



FOR EARLY DESIGN, SEE FIGURE 3-8.



SEE NOTE 4 ON PAGE 7-4  
 \*SEE NOTE 5 ON PAGE 7-4  
 \*\*SEE NOTE 6 ON PAGE 7-4

EARLY DESIGN PARTS

FIGURE 3-8 SPACE SUPPRESSION MECHANISM

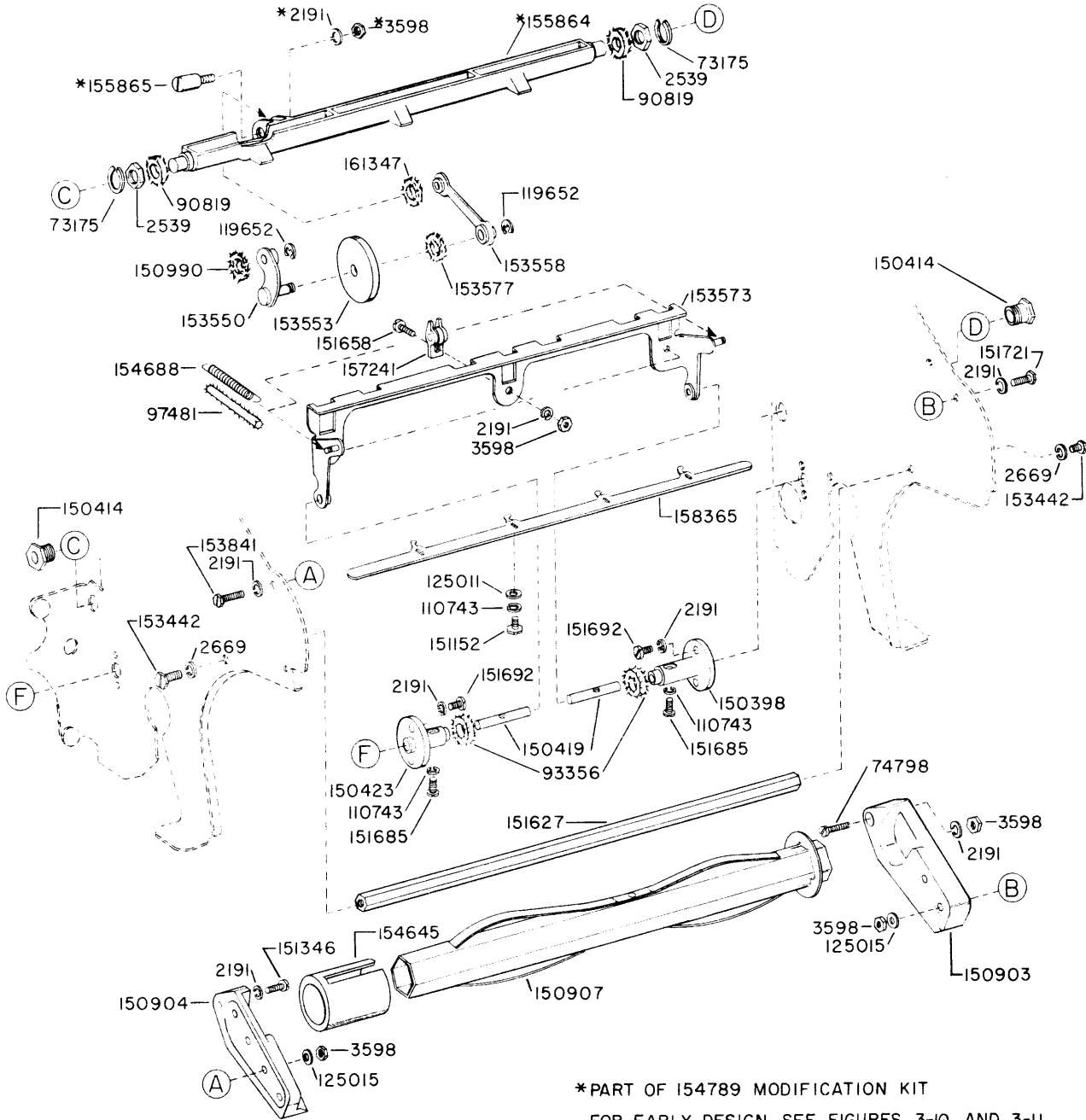
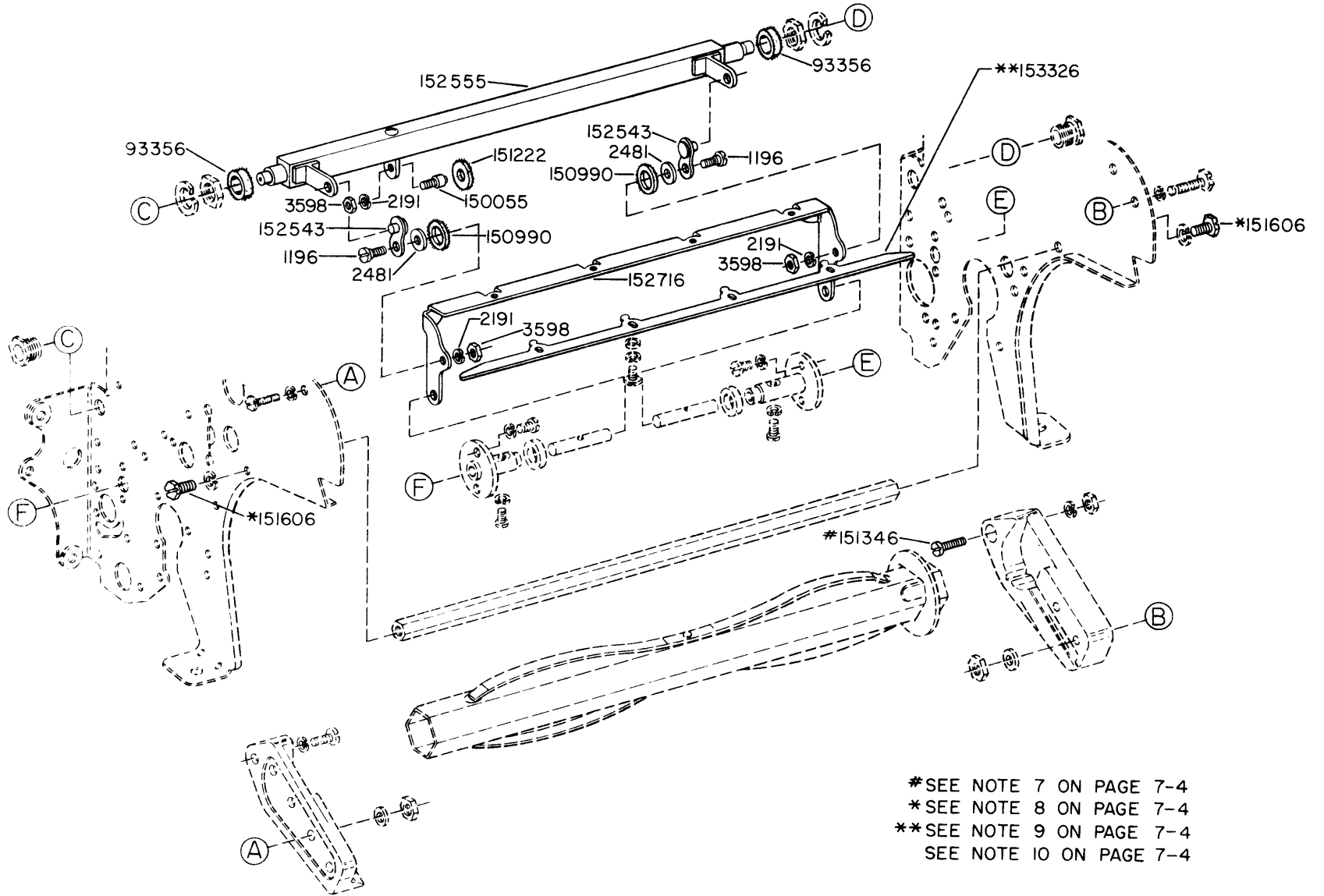


FIGURE 3-9. PAPER SPINDLE AND RESET BAIL MECHANISM

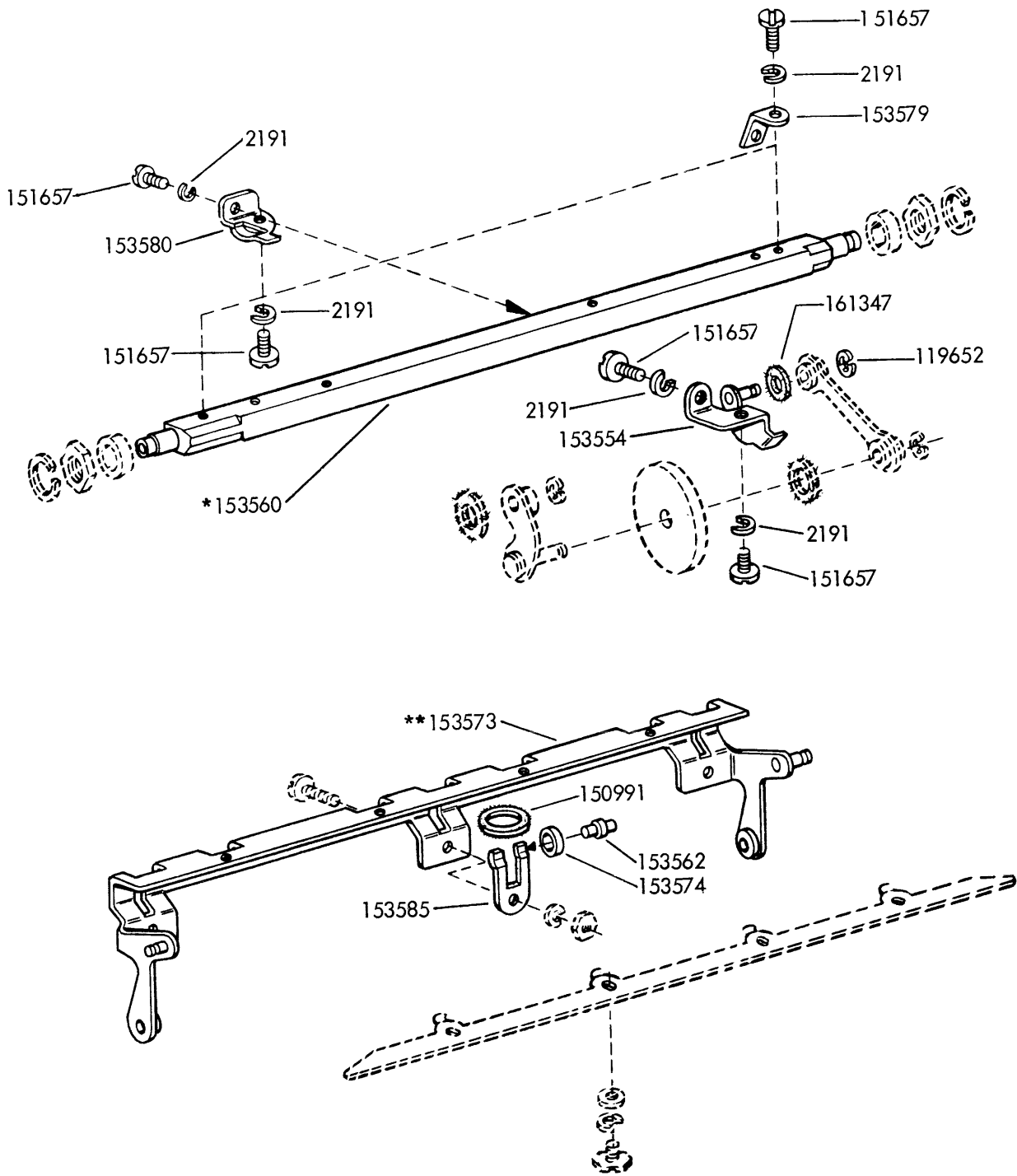


FIGURE 3-10 PAPER SPINDLE AND RESET BAIL MECHANISM



\*SEE NOTE 7 ON PAGE 7-4  
\*SEE NOTE 8 ON PAGE 7-4  
\*\*SEE NOTE 9 ON PAGE 7-4  
SEE NOTE 10 ON PAGE 7-4

EARLY DESIGN PARTS

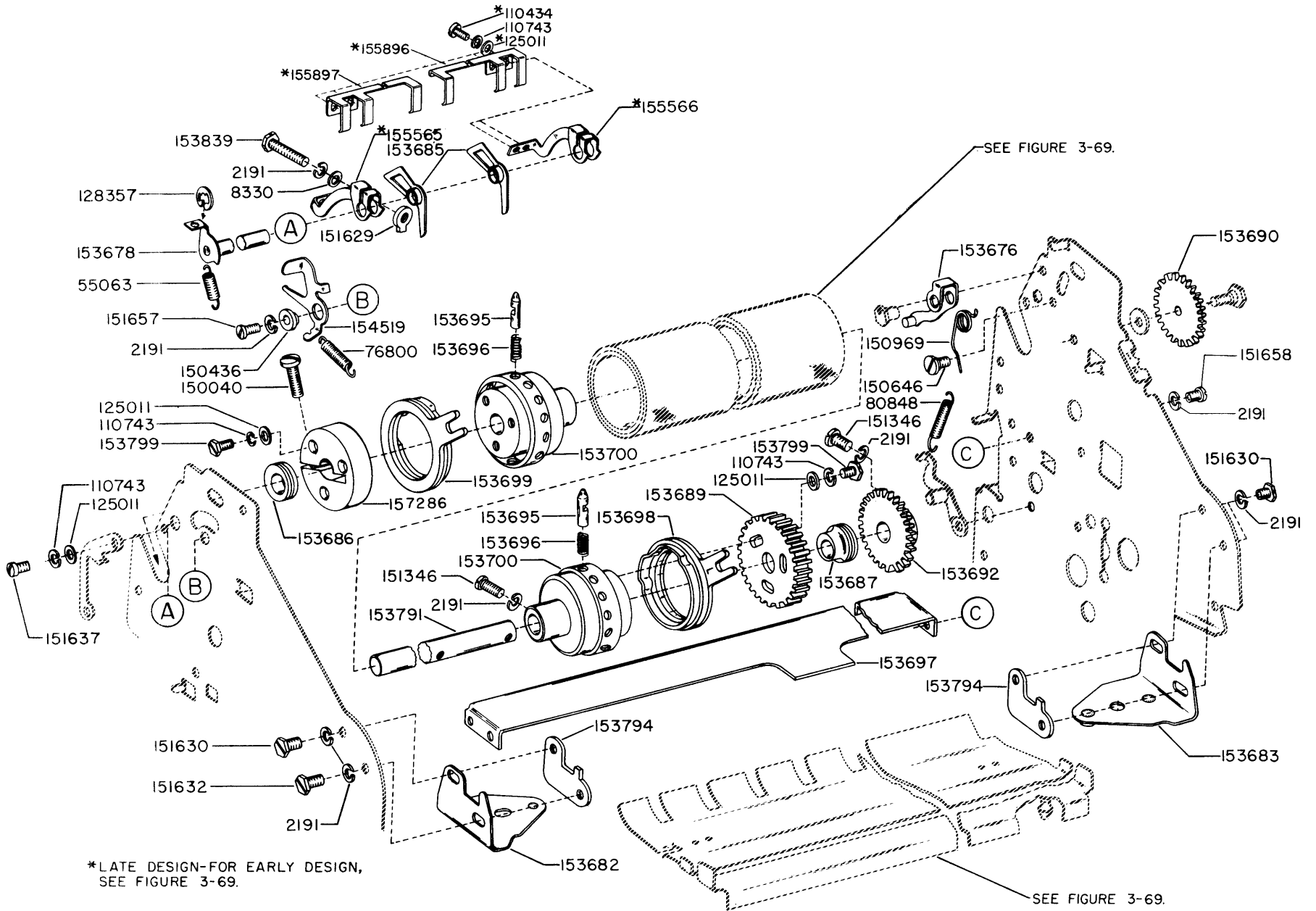


\*SEE NOTE 11 ON PAGE 7-4  
\*\*SEE NOTE 12 ON PAGE 7-4

EARLY DESIGN PARTS

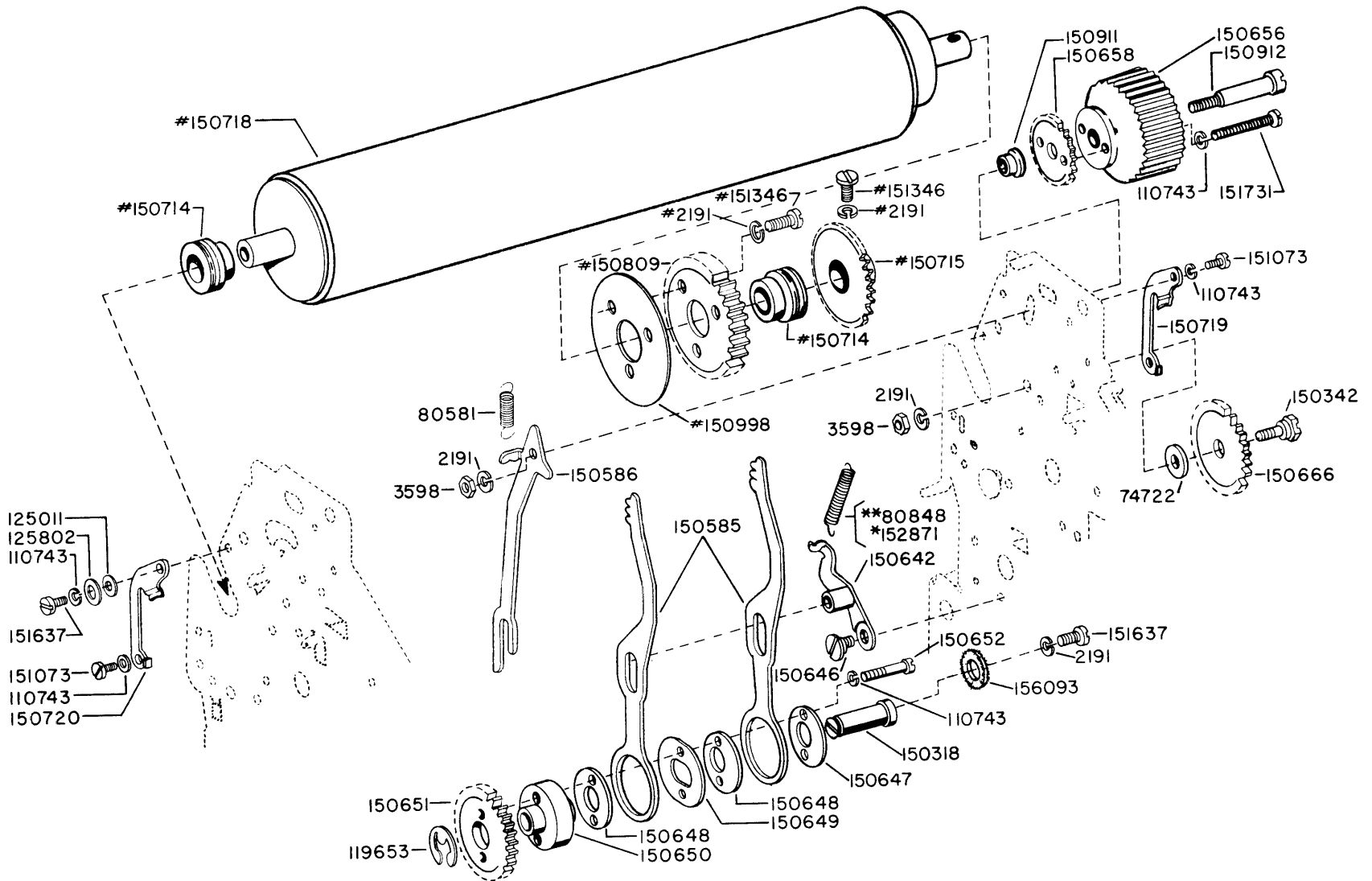
FIGURE 3-II. RESET BAIL MECHANISM

FIGURE 3-12. SPROCKET FEED MECHANISM



\*LATE DESIGN-FOR EARLY DESIGN, SEE FIGURE 3-69.

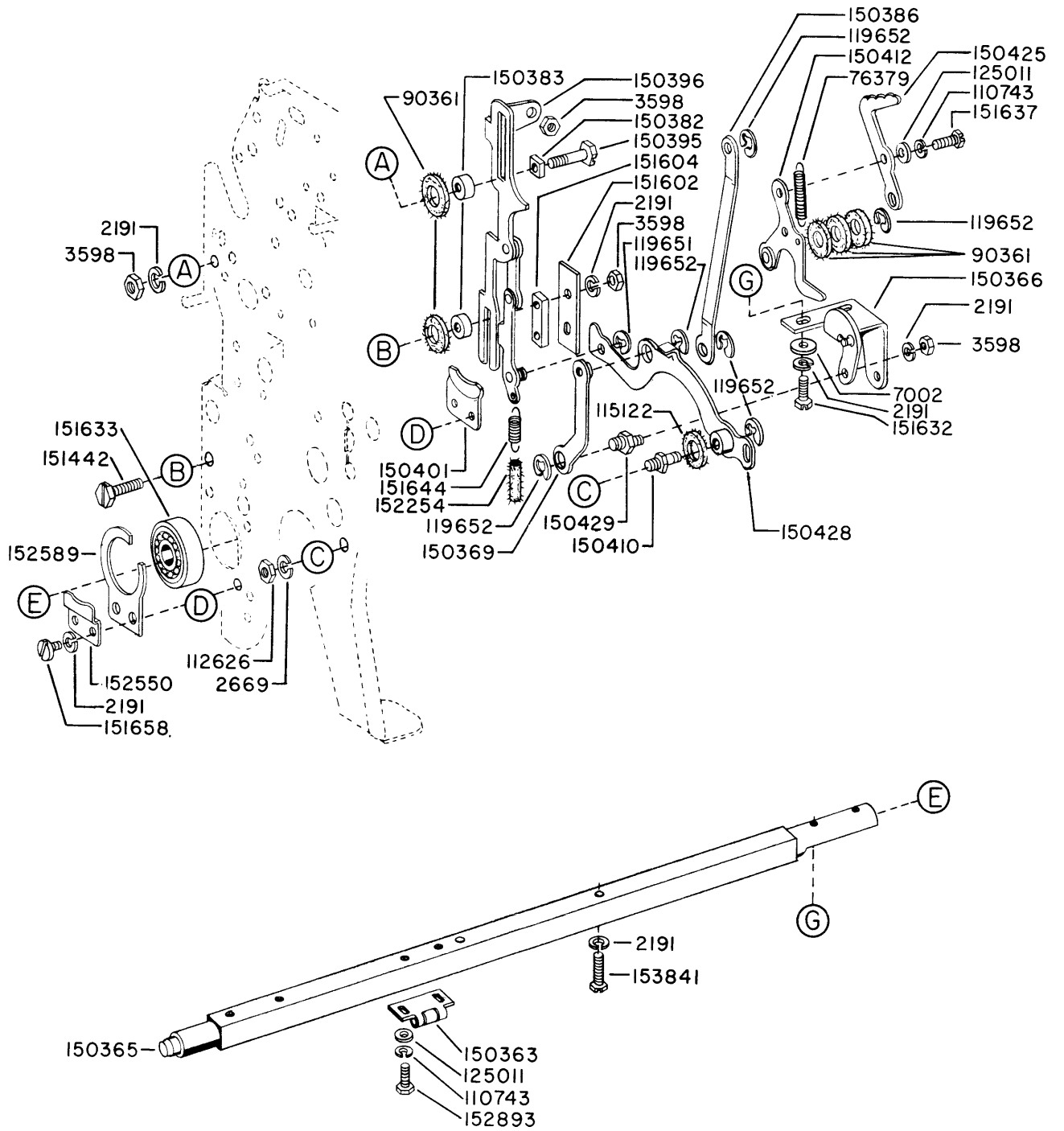
FIGURE 3-13 LINE FEED AND PLATEN MECHANISM



- \* PECULIAR TO FRICTION FEED UNITS.
- \*\* PECULIAR TO SPROCKET FEED UNITS.

\*PART OF 150833 PLATEN ASSEMBLY

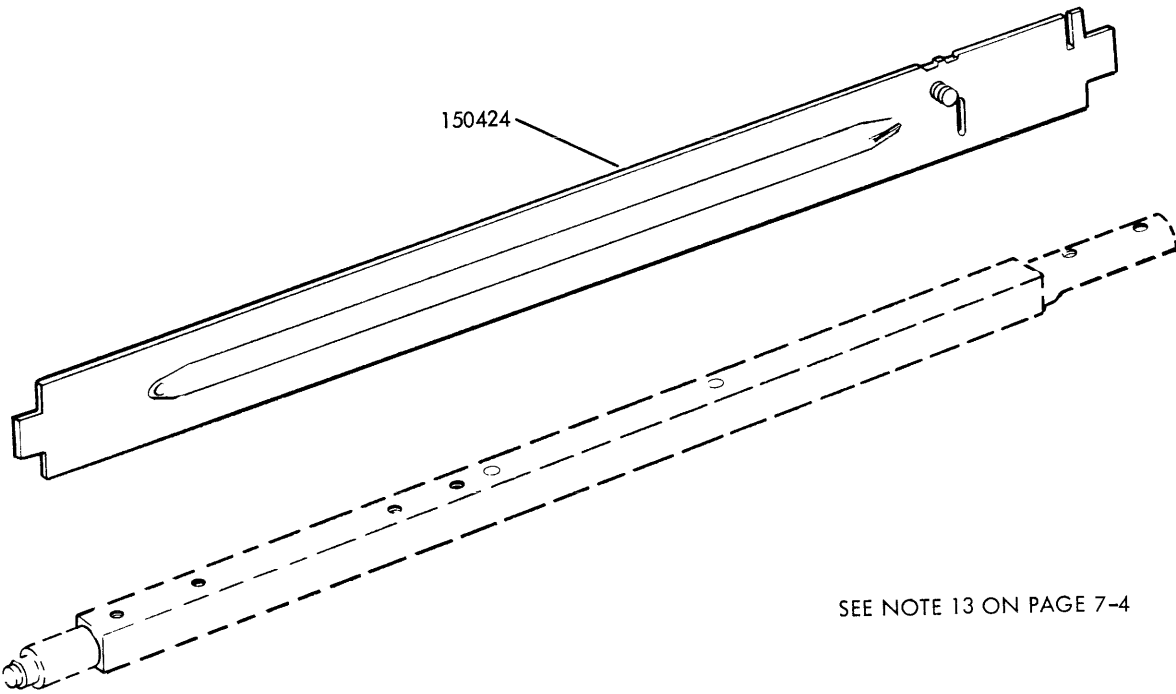
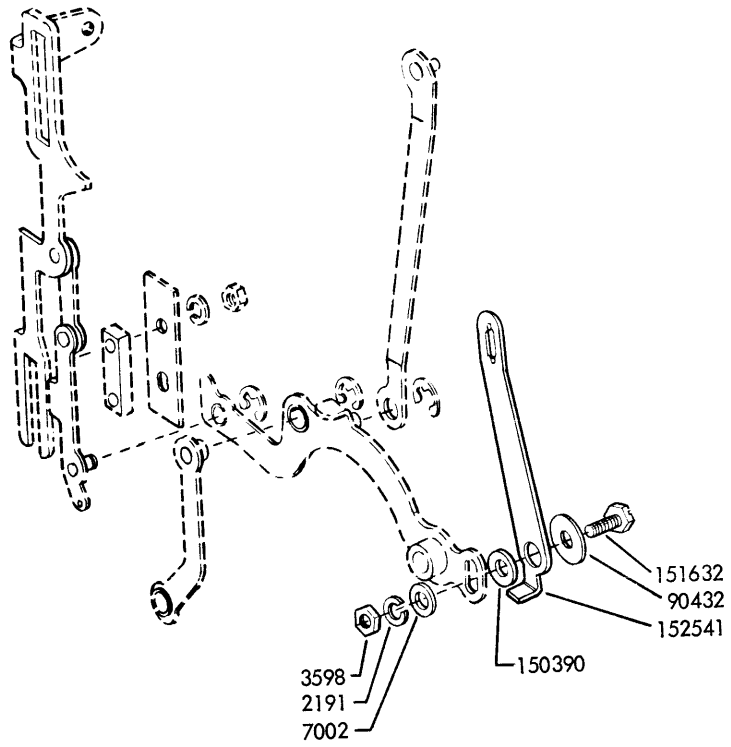
1149B



FOR EARLY DESIGN, SEE FIGURE 3-15.

FIGURE 3-14. LEFT SIDE LINKAGE AND ROCKER SHAFT MECHANISM

1149B

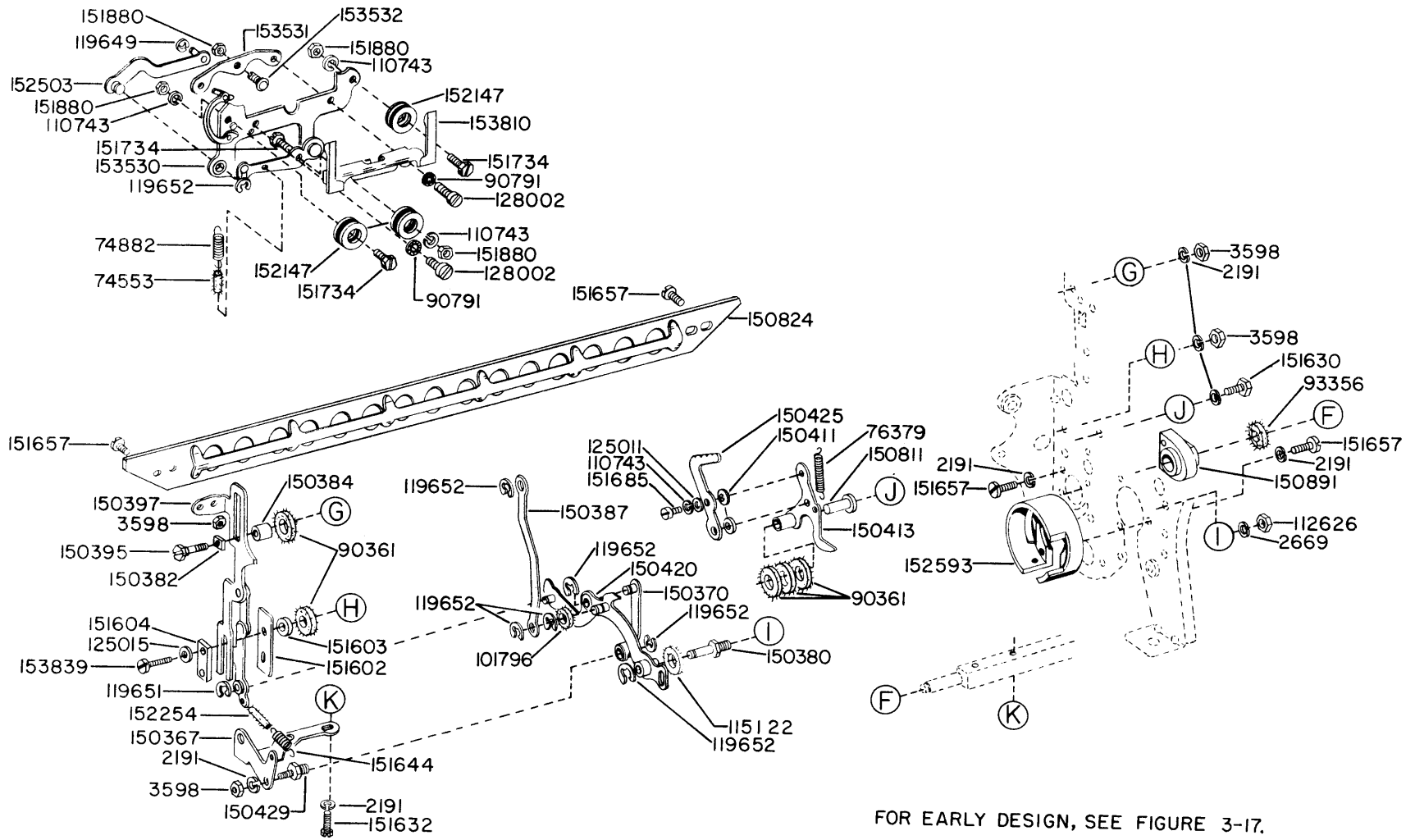


SEE NOTE 13 ON PAGE 7-4

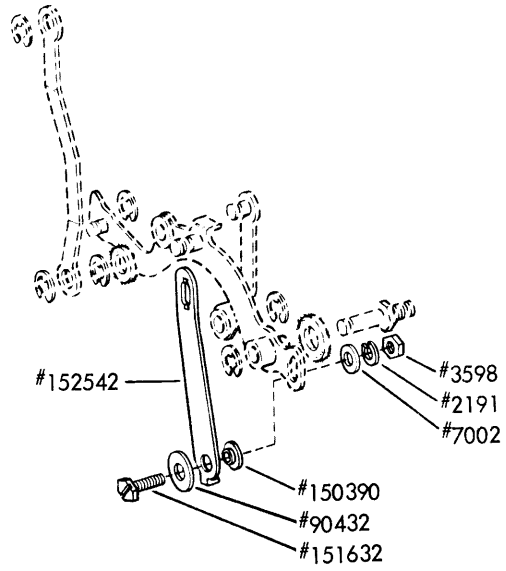
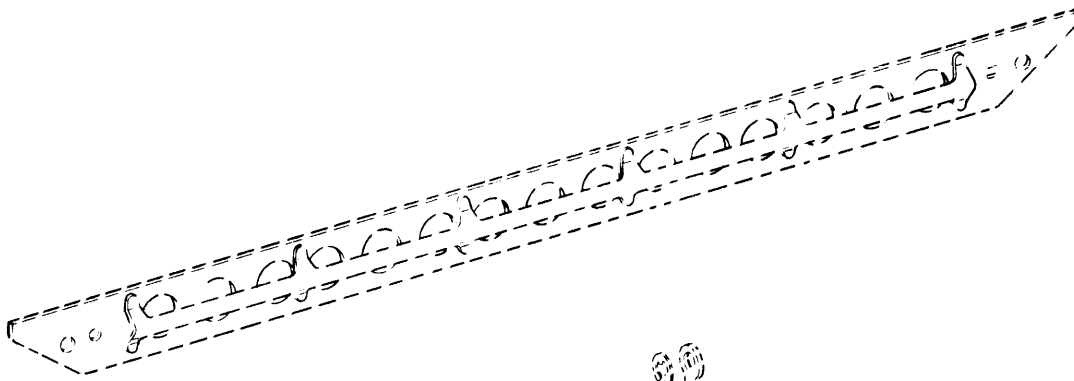
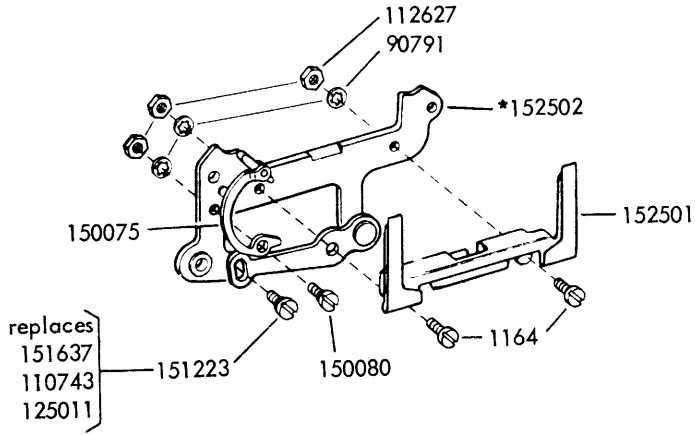
EARLY DESIGN PARTS

FIGURE 3-15. LEFT SIDE LINKAGE AND STRIPPER BLADE MECHANISM

FIGURE 3-16. RIGHT SIDE LINKAGE AND TYPE BOX CARRIAGE MECHANISM



FOR EARLY DESIGN, SEE FIGURE 3-17.



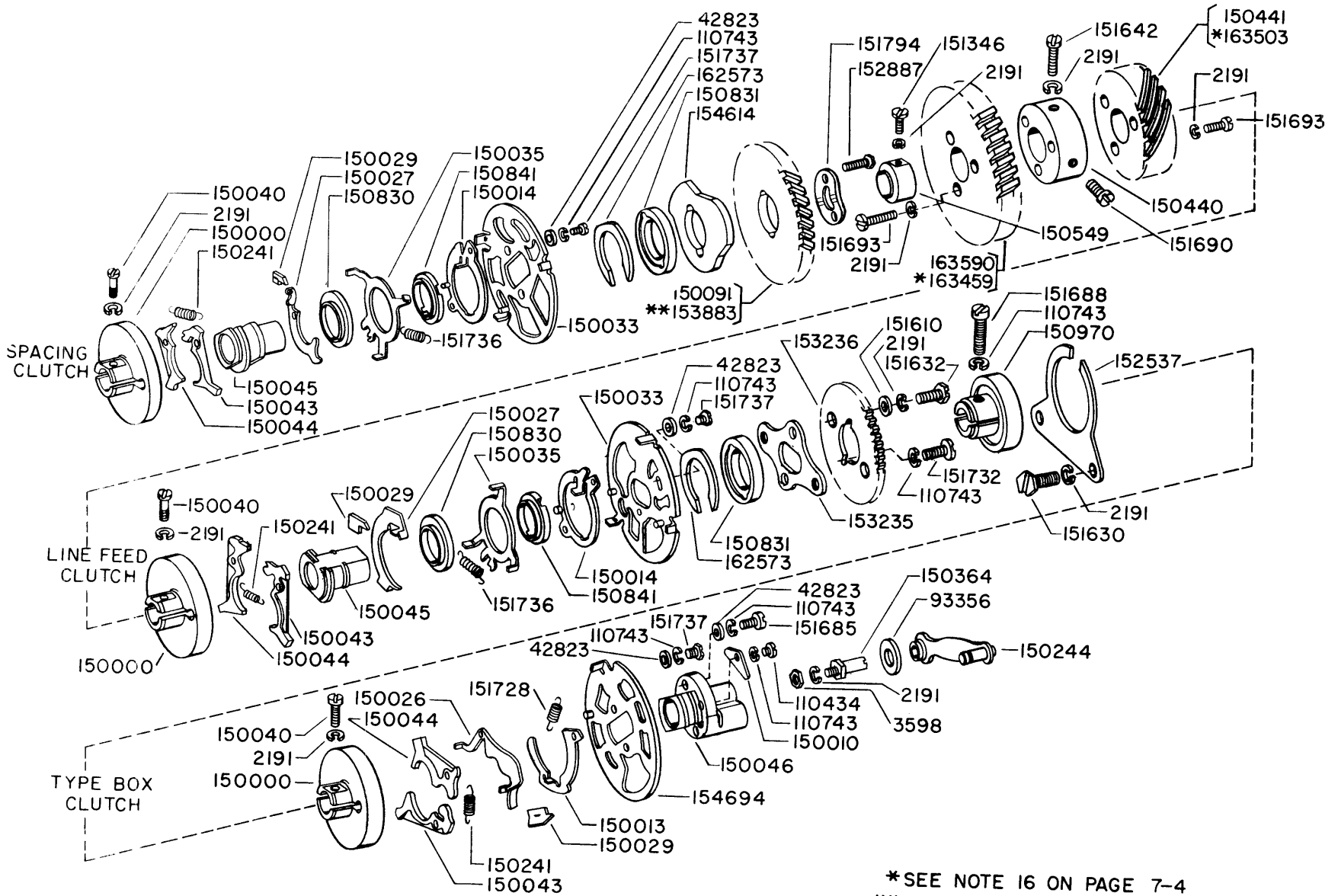
#SEE NOTE 14 ON PAGE 7-4  
 \*SEE NOTE 15 ON PAGE 7-4

EARLY DESIGN PARTS

FIGURE 3-17. RIGHT SIDE LINKAGE AND TYPE BOX CARRIAGE MECHANISM



FIGURE 3-18. MAIN SHAFT MECHANISM

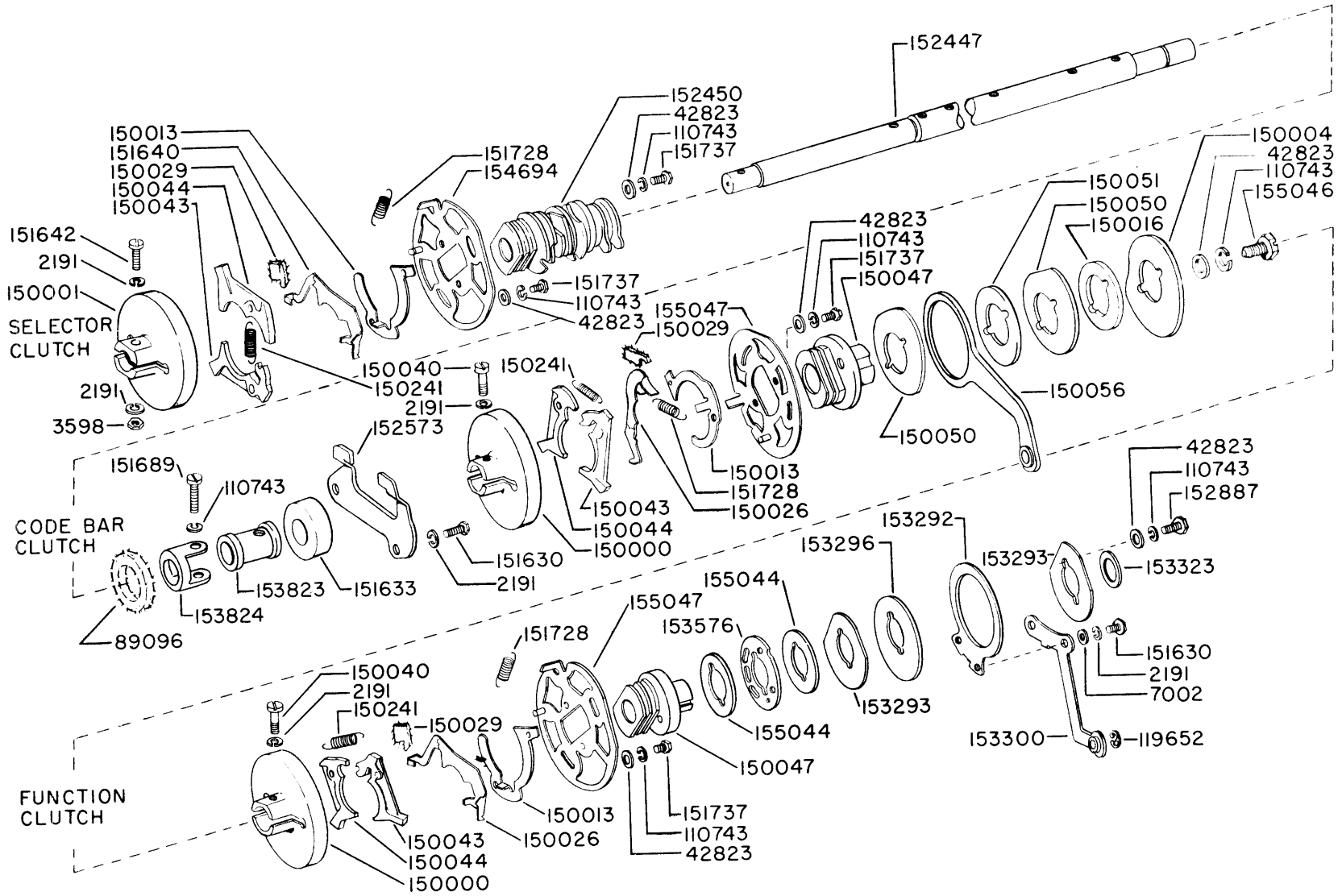


11498

\* SEE NOTE 16 ON PAGE 7-4  
 \*\* SEE NOTE 17 ON PAGE 7-4

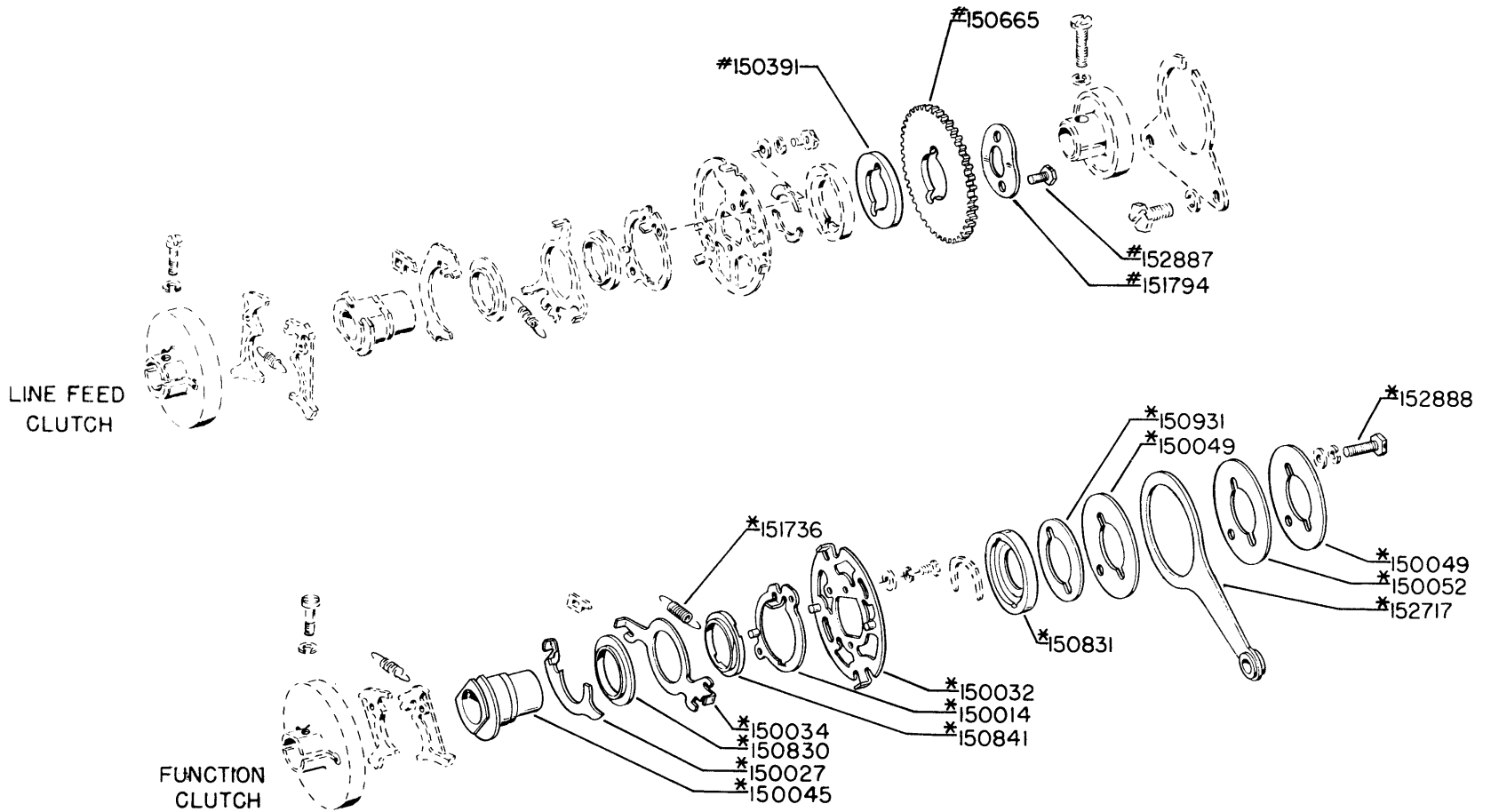
FOR EARLY DESIGN, SEE FIGURE 3-20.

FIGURE 3-19. MAIN SHAFT MECHANISM



11498

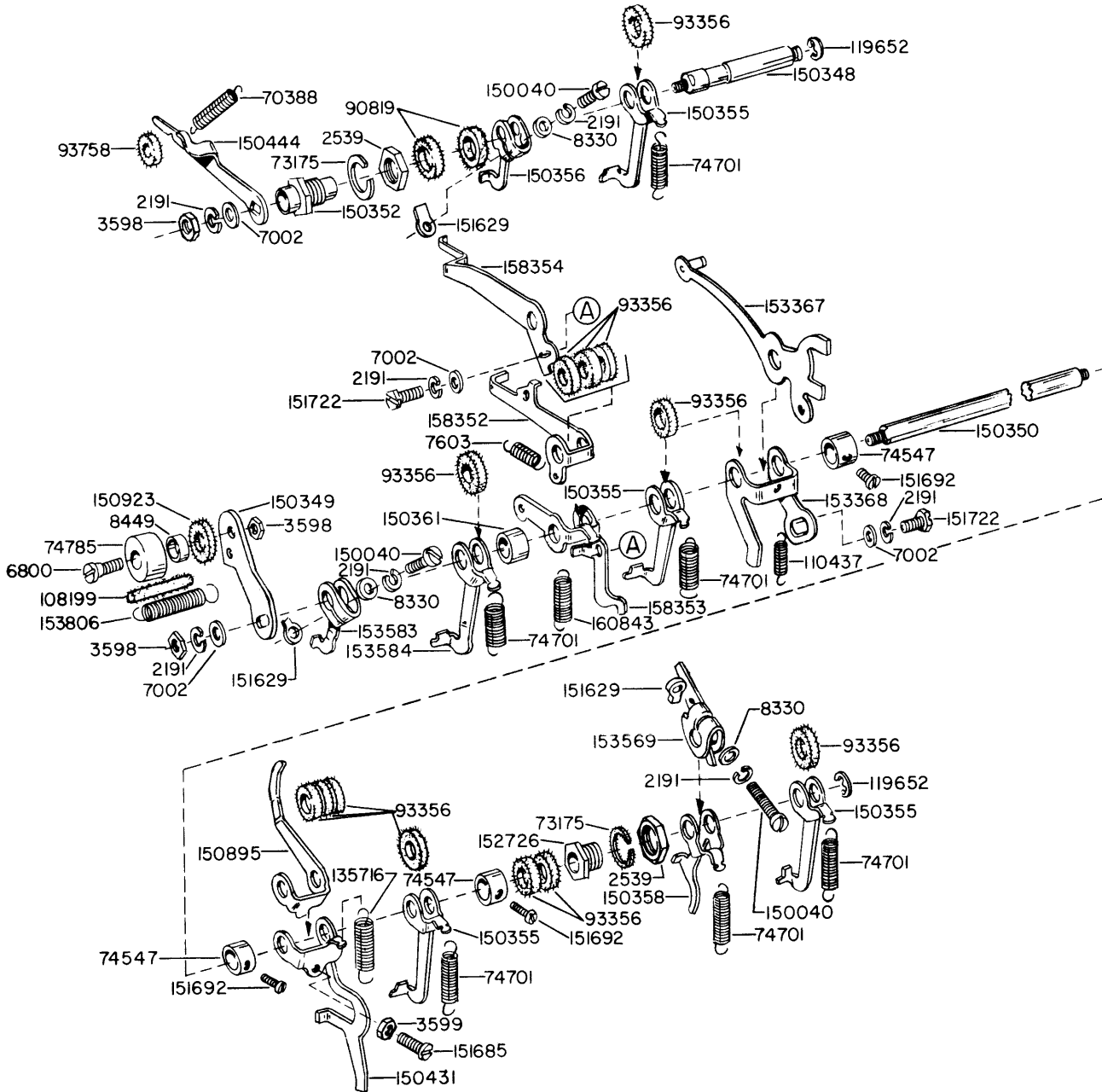
FOR EARLY DESIGN, SEE FIGURE 3-20.



11498

# SEE NOTE 18 ON PAGE 7-4  
 \* SEE NOTE 19 ON PAGE 7-4

EARLY DESIGN PARTS



FOR EARLY DESIGN, SEE FIGURE 3-22.

FIGURE 3-21. TRIP SHAFT MECHANISM

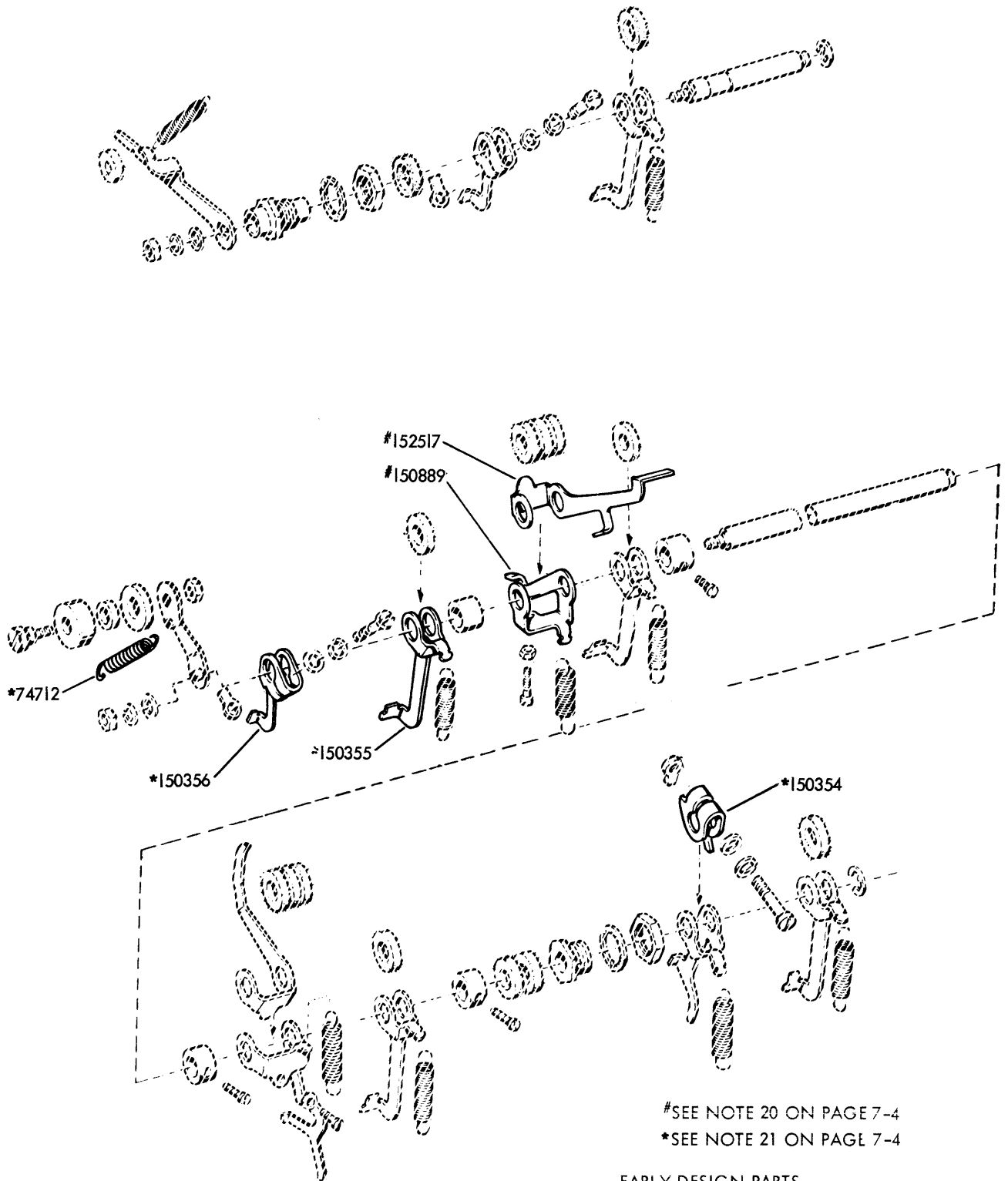
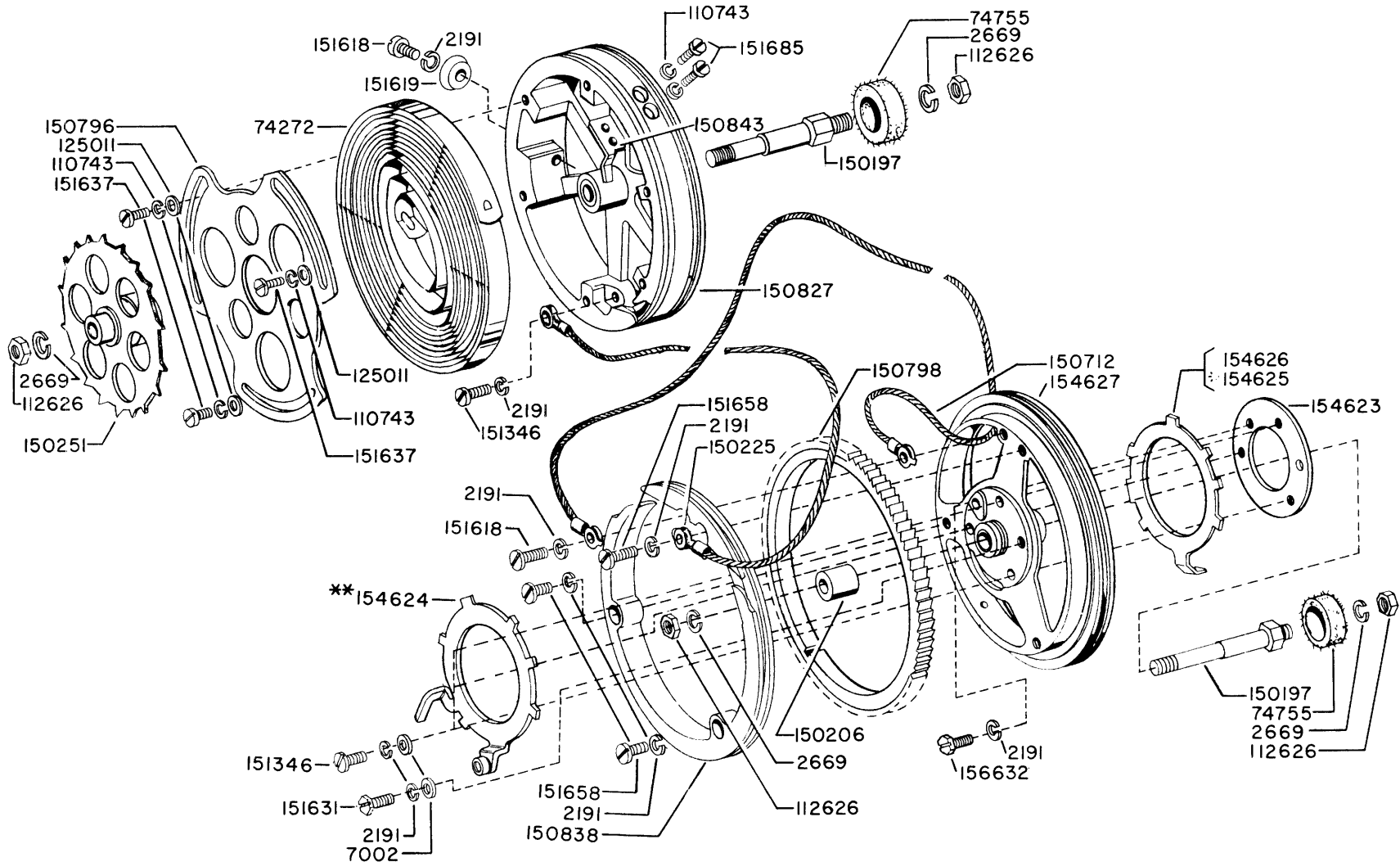


FIGURE 3-22. TRIP SHAFT MECHANISM

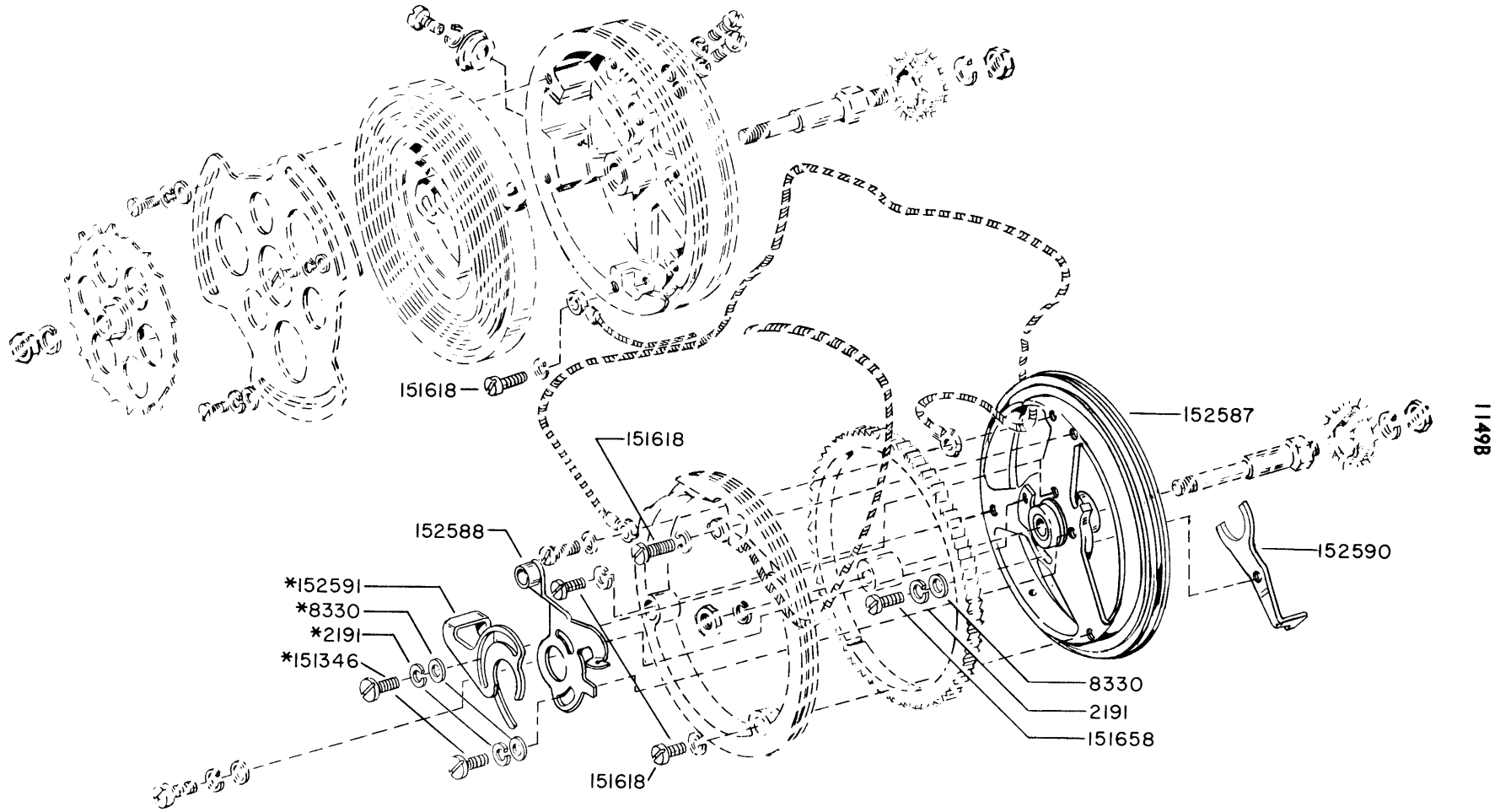
FIGURE 3-23. SPRING DRUM AND SPACING DRUM MECHANISM



\*\* THE 154624 RING HAS BEEN REDESIGNED BUT RETAINS ITS ORIGINAL NUMBER

\*SEE NOTE 22 ON PAGE 7-4 FOR EARLY DESIGN, SEE FIGURE 3-24

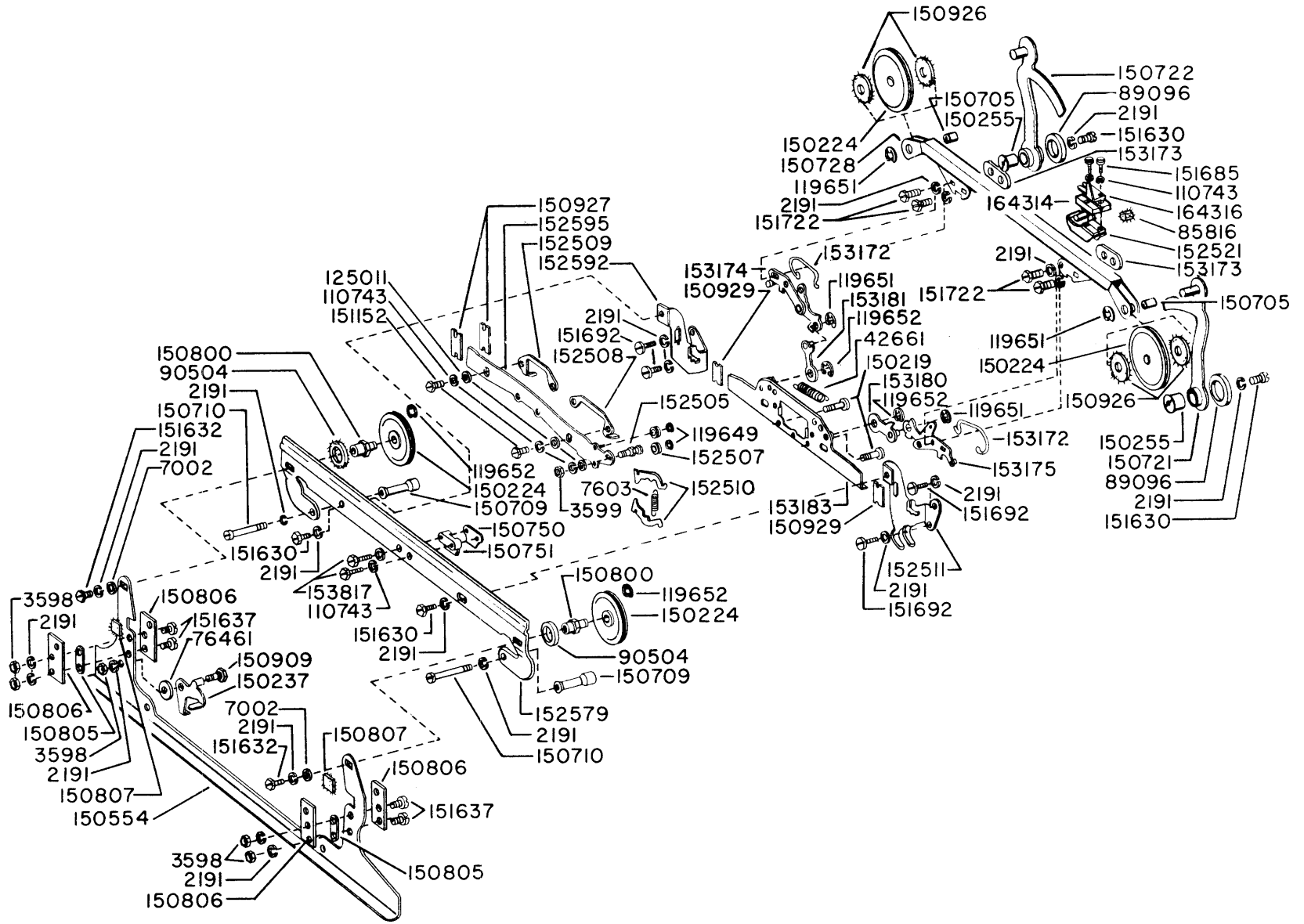
FIGURE 3-24 SPRING DRUM AND SPACING DRUM MECHANISM



SEE NOTE 23 ON PAGE 7-4  
\*SEE NOTE 24 ON PAGE 7-4

EARLY DESIGN PARTS

FIGURE 3-25 FRONT PLATE MECHANISM

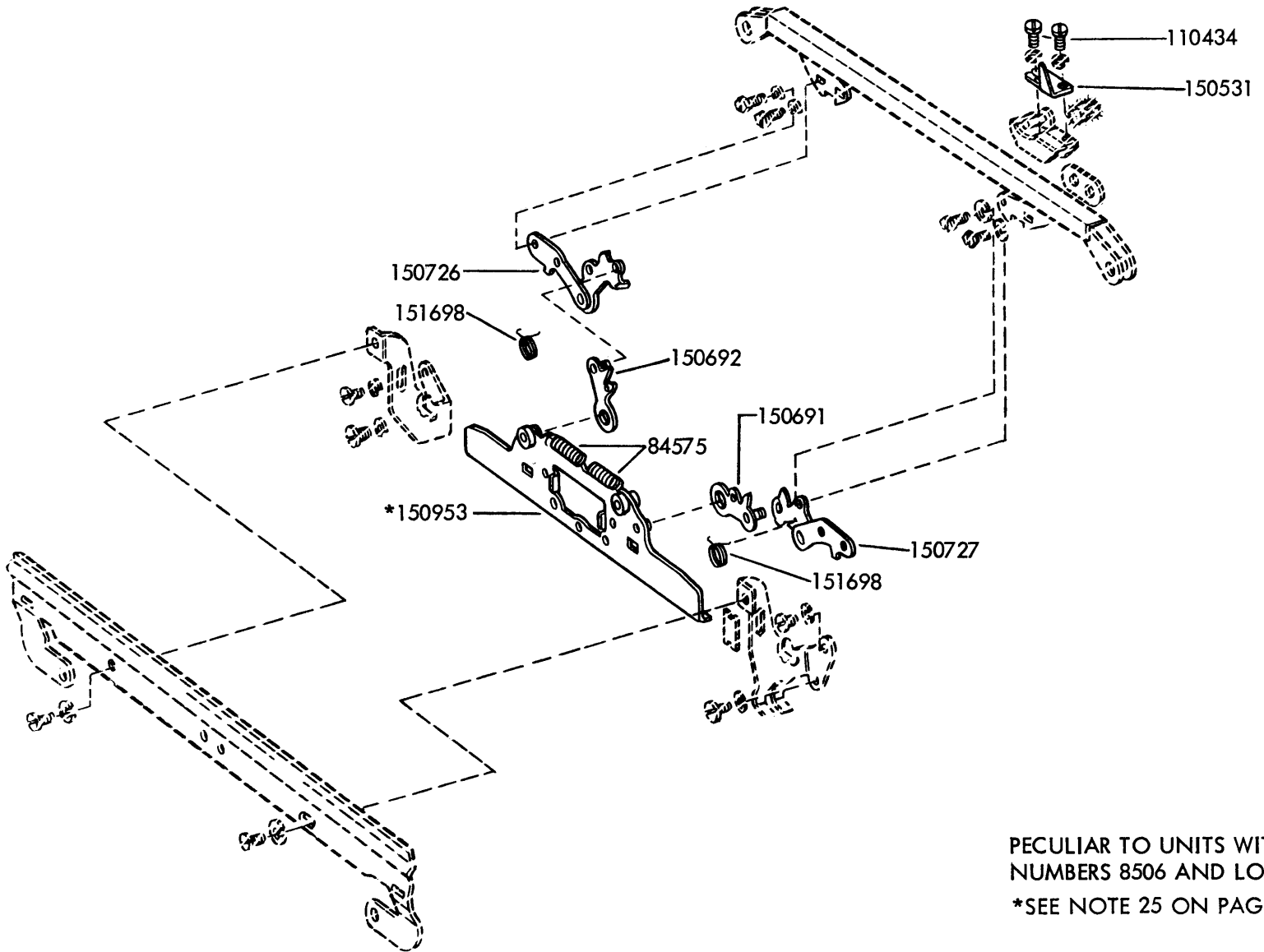


11498

FOR EARLY DESIGN, SEE FIGURE 3-26.



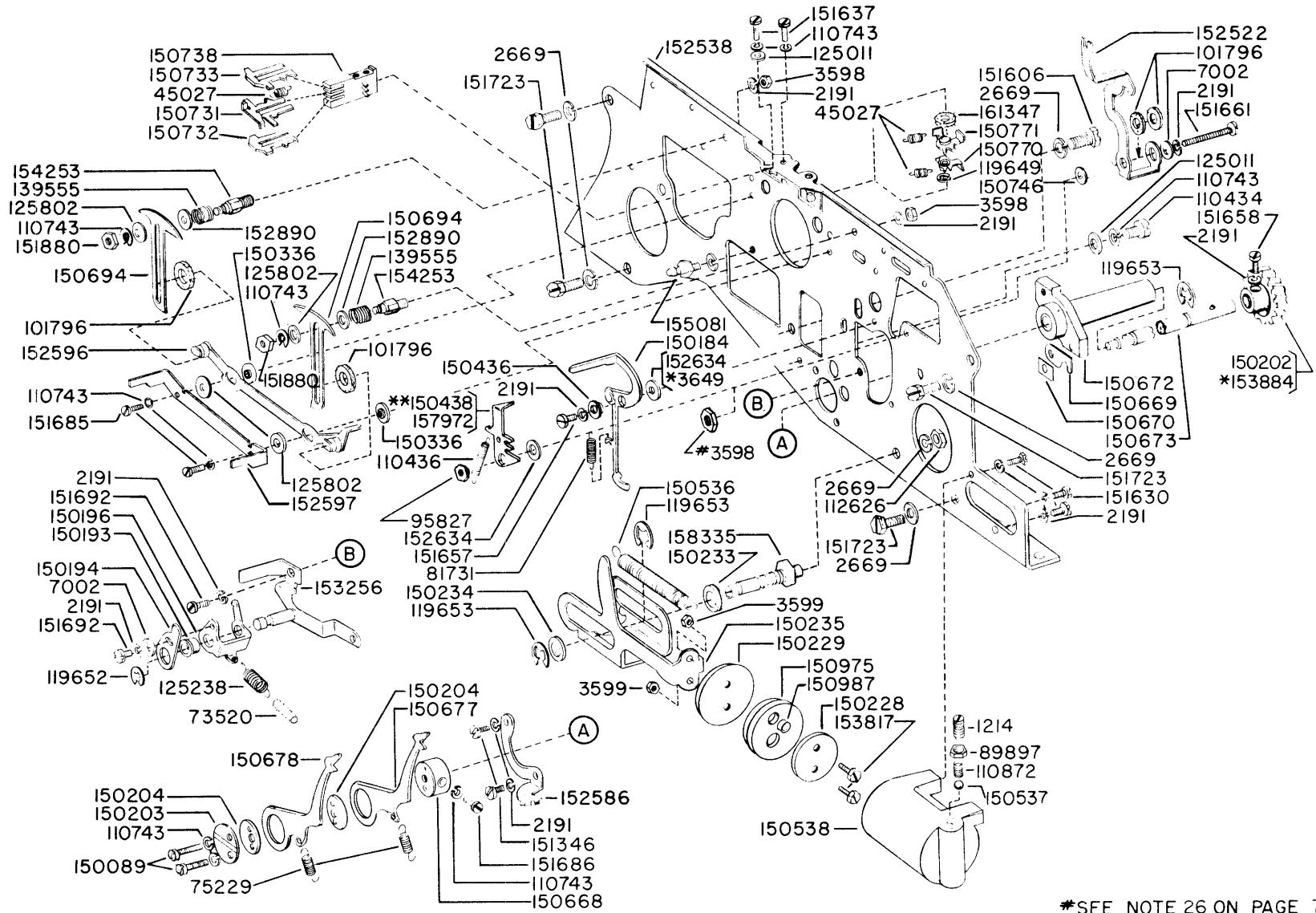
FIGURE 3-26. FRONT PLATE MECHANISM



PECULIAR TO UNITS WITH SERIAL  
NUMBERS 8506 AND LOWER  
\*SEE NOTE 25 ON PAGE 7-4

EARLY DESIGN PARTS

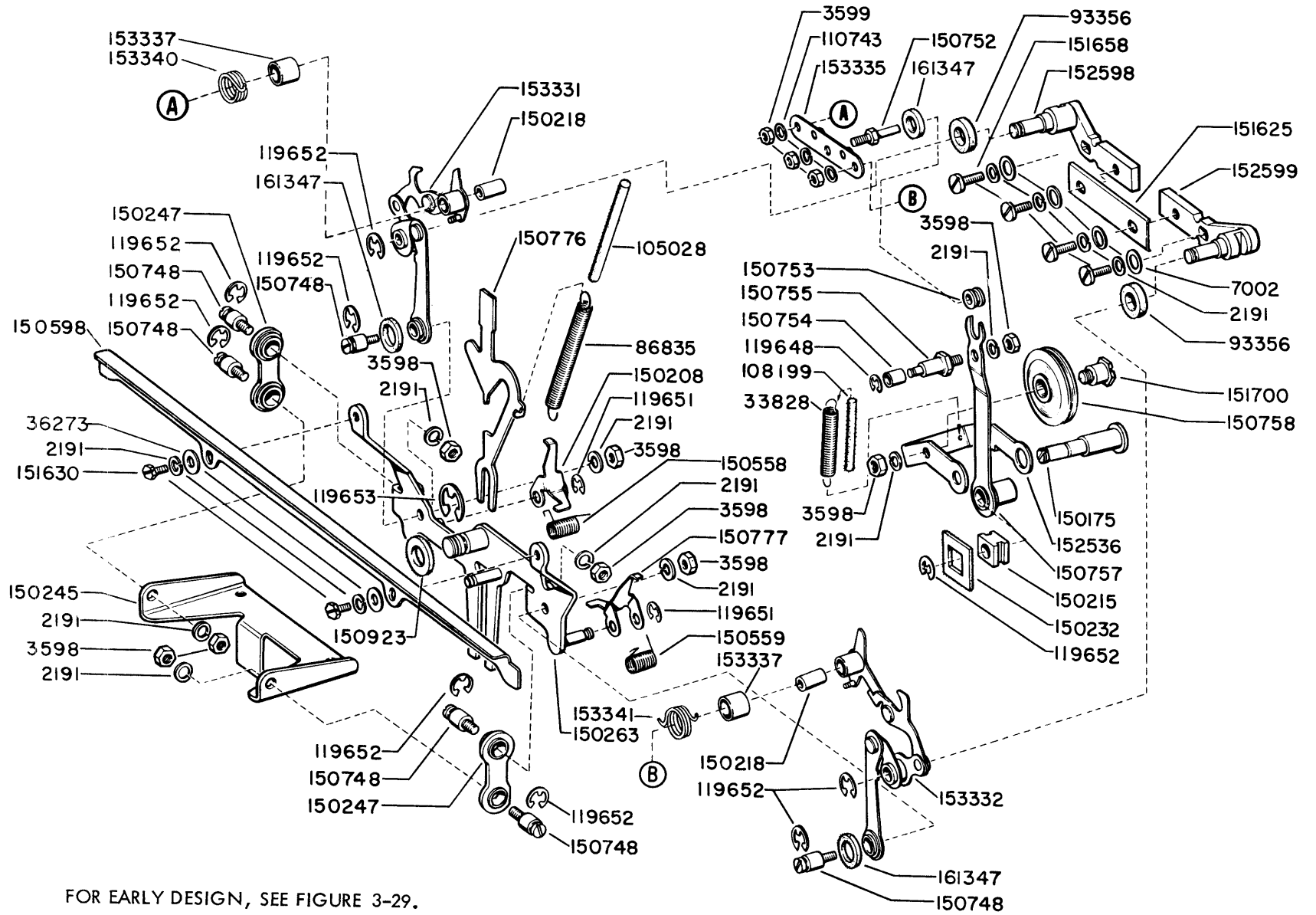
FIGURE 3-27. FRONT PLATE MECHANISM



11498

\*SEE NOTE 26 ON PAGE 7-4  
 \*SEE NOTE 27 ON PAGE 7-5  
 \*\*SEE NOTE 28 ON PAGE 7-5

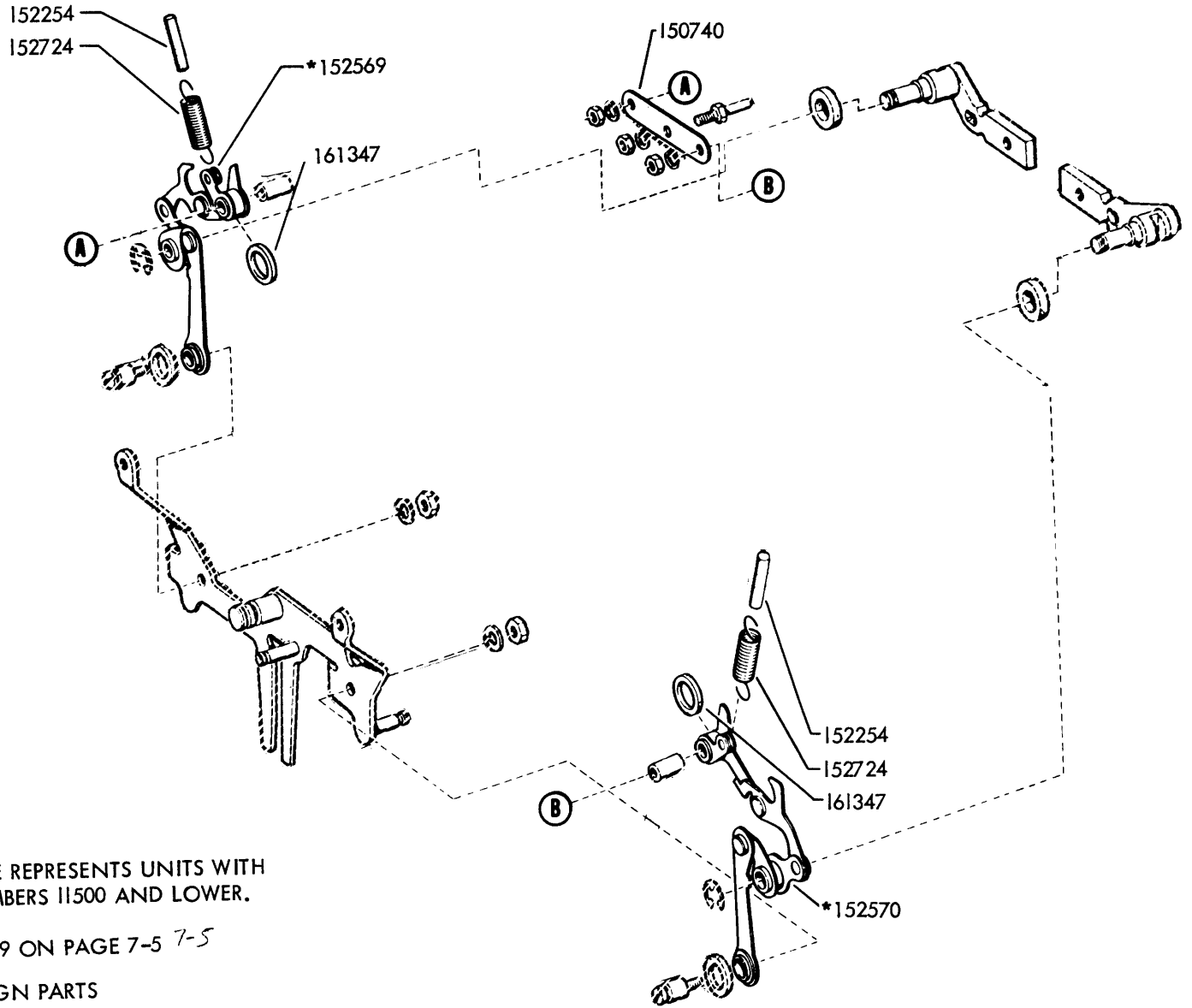
FIGURE 3-28. FRONT PLATE MECHANISM



11498

FOR EARLY DESIGN, SEE FIGURE 3-29.

FIGURE 3-29 FRONT PLATE MECHANISM

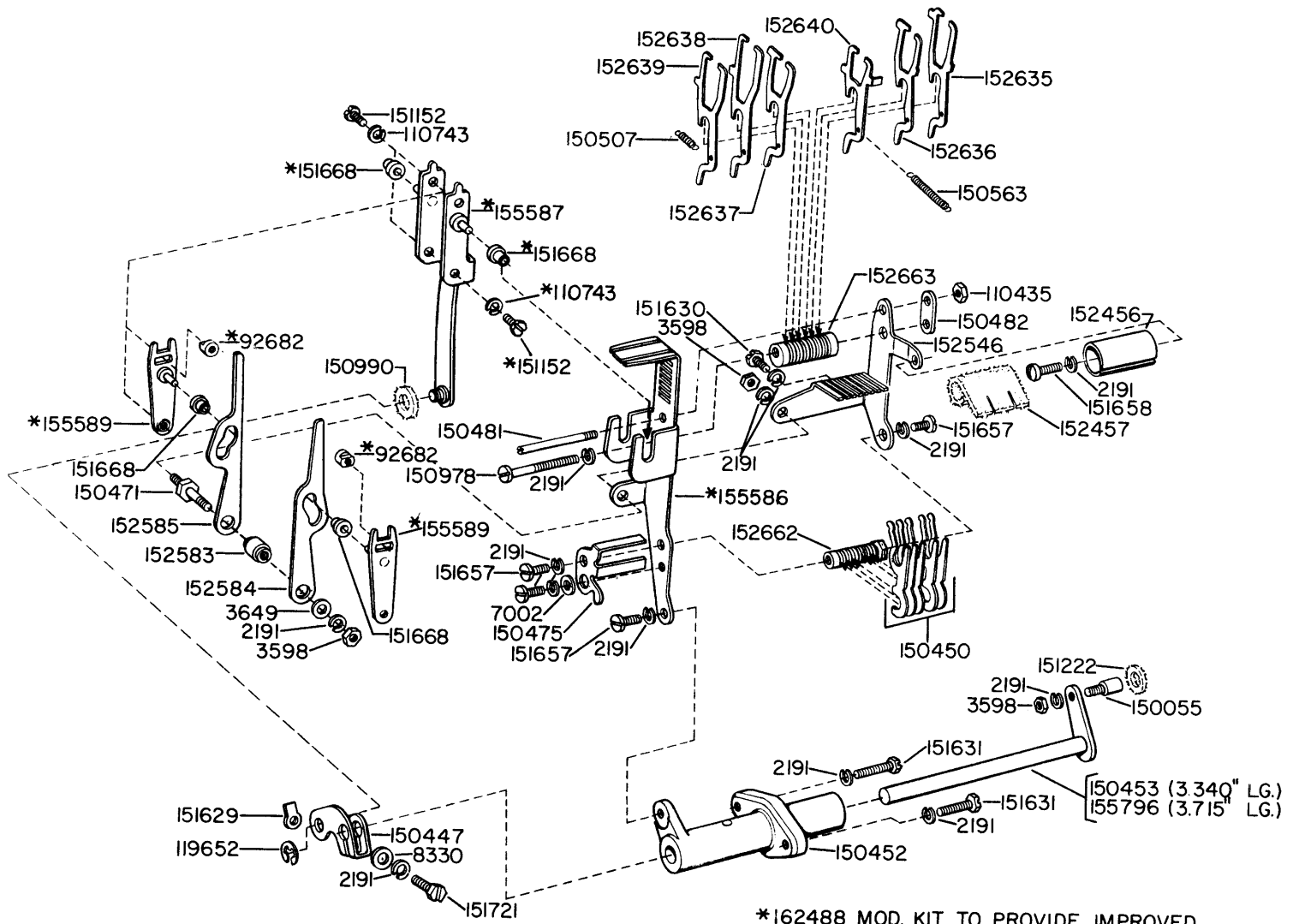


THIS FIGURE REPRESENTS UNITS WITH SERIAL NUMBERS 11500 AND LOWER.

\*SEE NOTE 29 ON PAGE 7-5 7-5

EARLY DESIGN PARTS

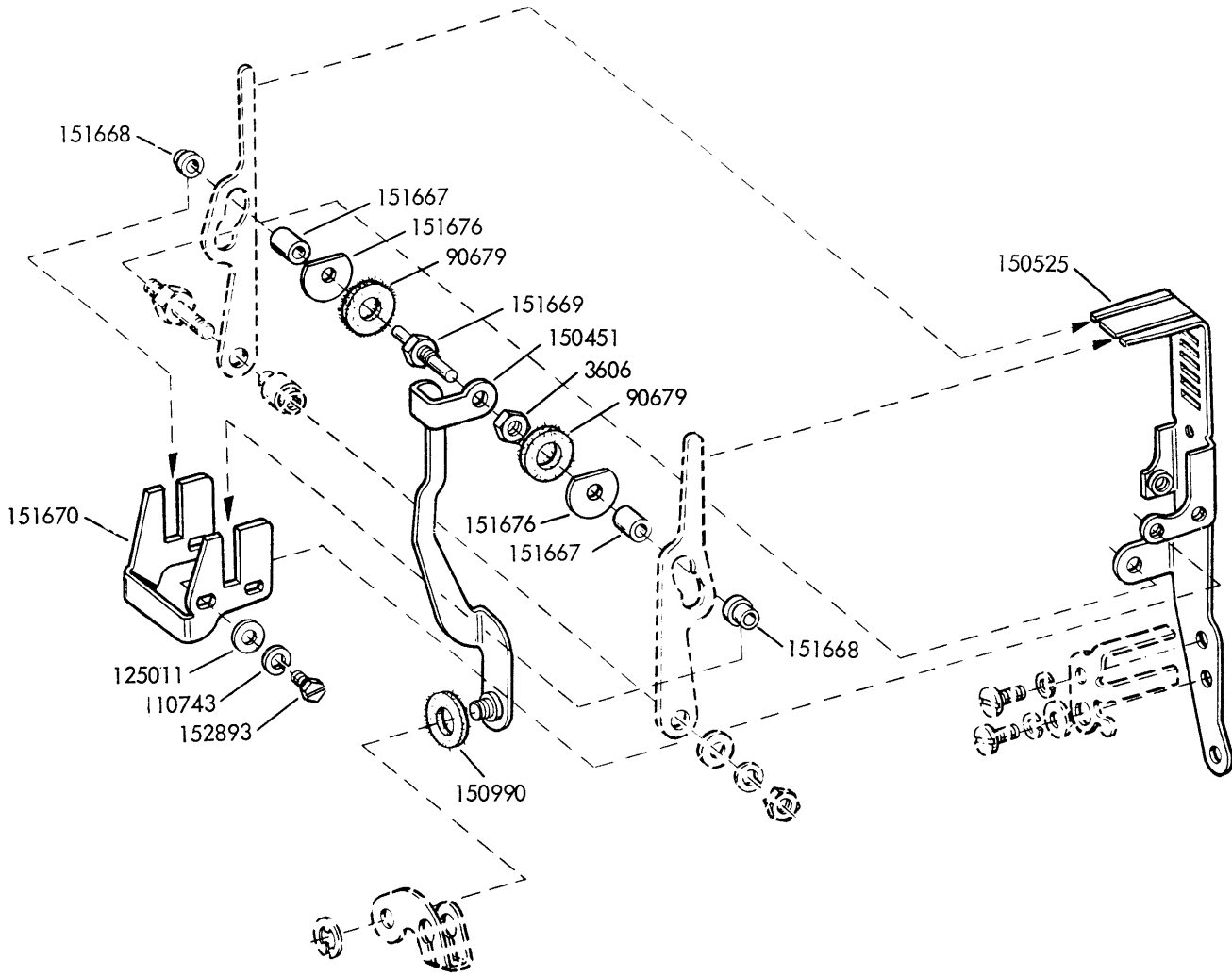
FIGURE 3-30. CODE BAR POSITIONING MECHANISM



11498

\*162488 MOD. KIT TO PROVIDE IMPROVED CODE BAR POSITIONING MECHANISM

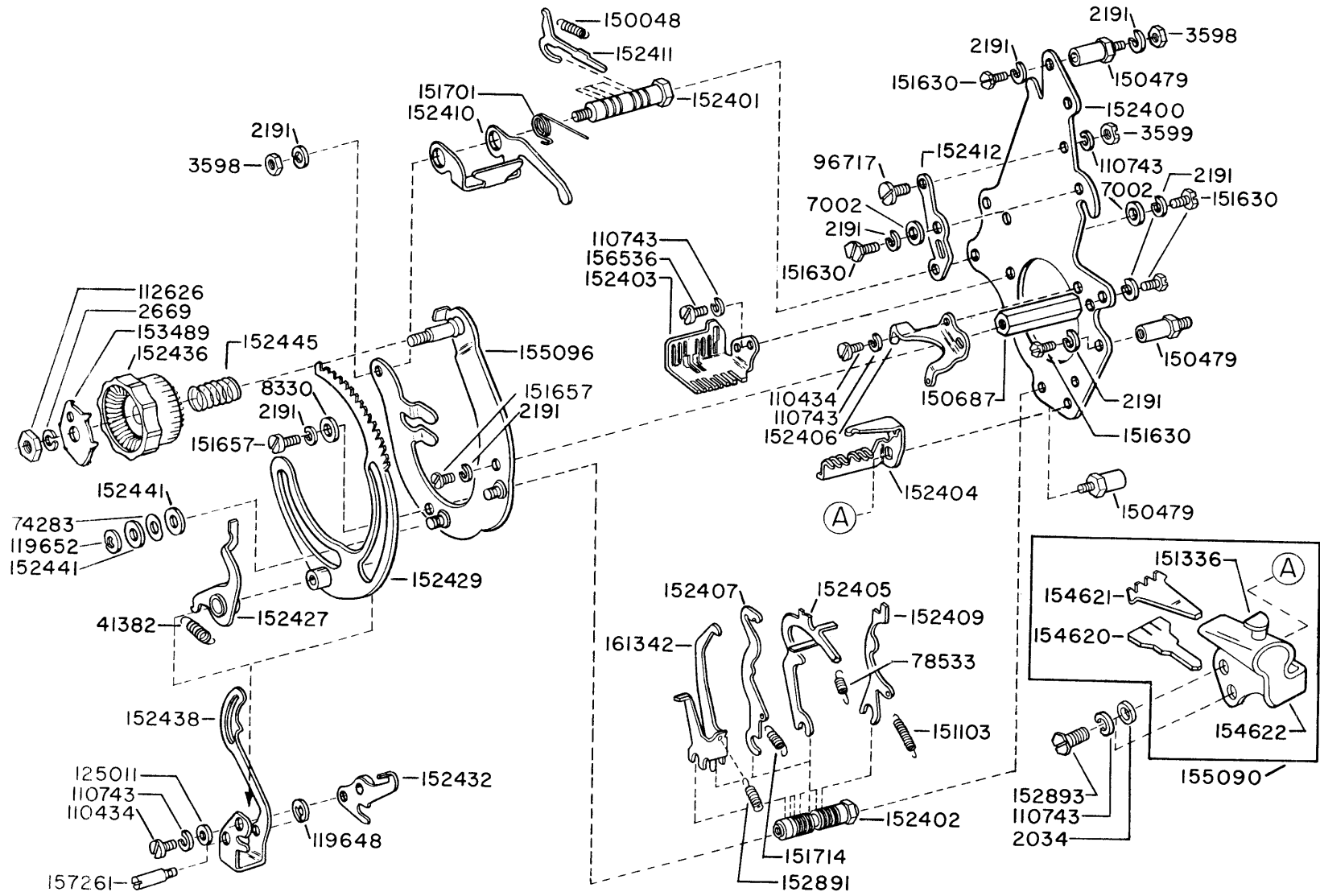
FOR EARLY DESIGN, SEE FIGURE 3-31.



EARLY DESIGN PARTS

FIGURE 3-31. CODE BAR POSITIONING MECHANISM

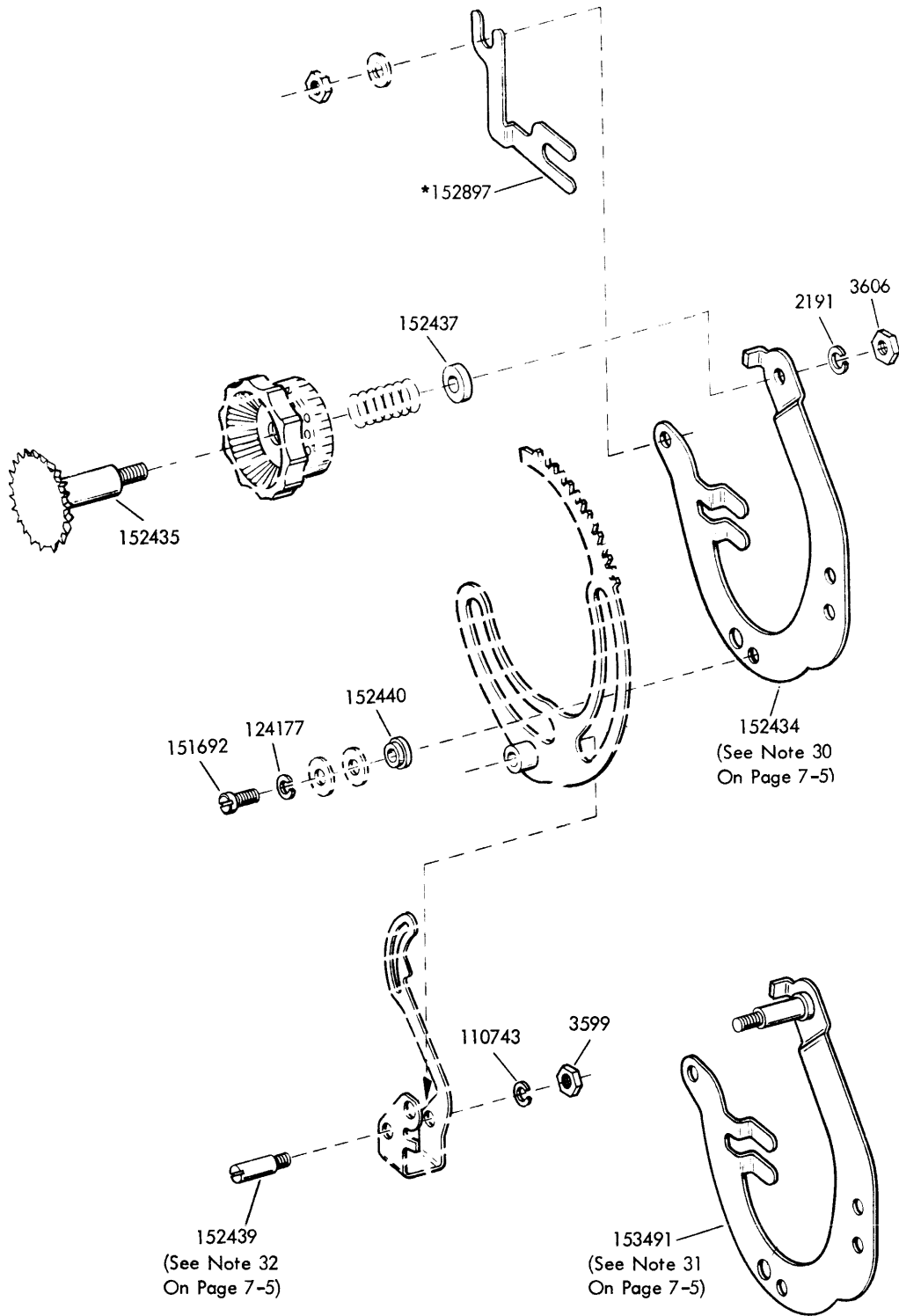
FIGURE 3-32. SELECTOR MECHANISM



11498

FOR EARLY DESIGN, SEE FIGURE 3-33.

1149B



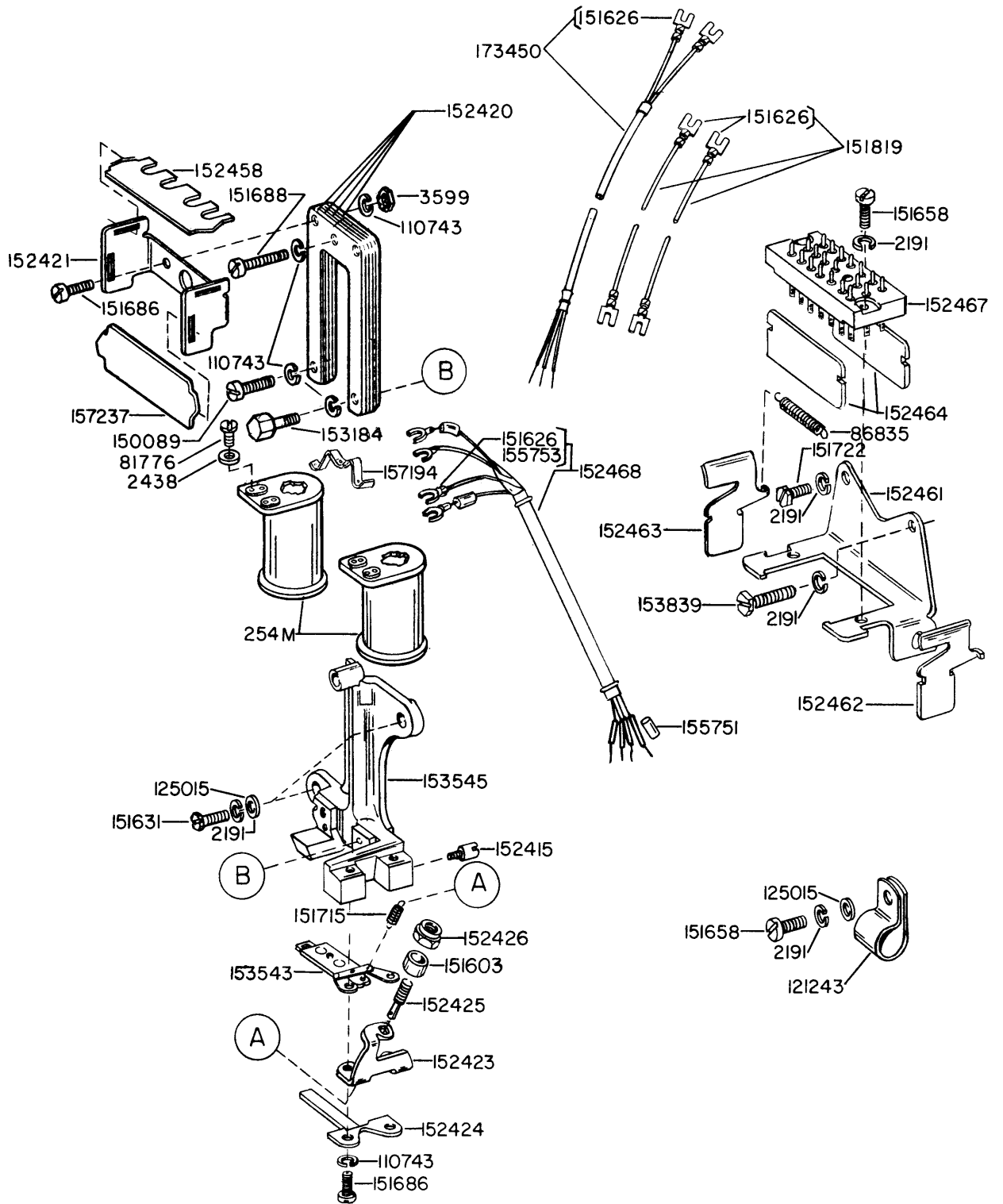
\*USED ON UNITS WITH SERIAL NUMBERS 11755 AND BELOW

EARLY DESIGN PARTS

FIGURE 3-33. SELECTOR KNOB MECHANISM



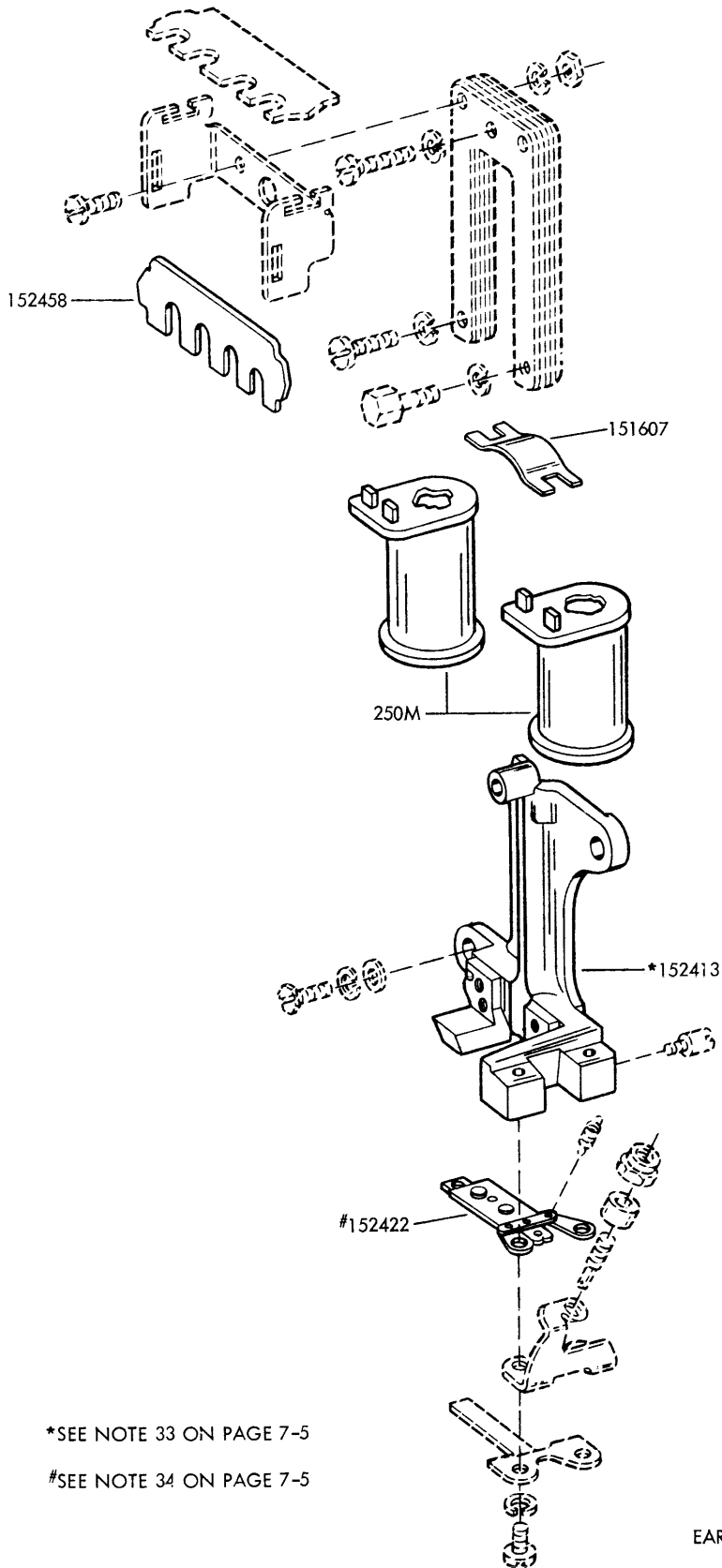
1149B



FOR EARLY DESIGN, SEE FIGURE 3-35.

FIGURE 3-34. SELECTOR MAGNET MECHANISM

1149B



\*SEE NOTE 33 ON PAGE 7-5

#SEE NOTE 34 ON PAGE 7-5

FIGURE 3-35. SELECTOR MAGNET MECHANISM

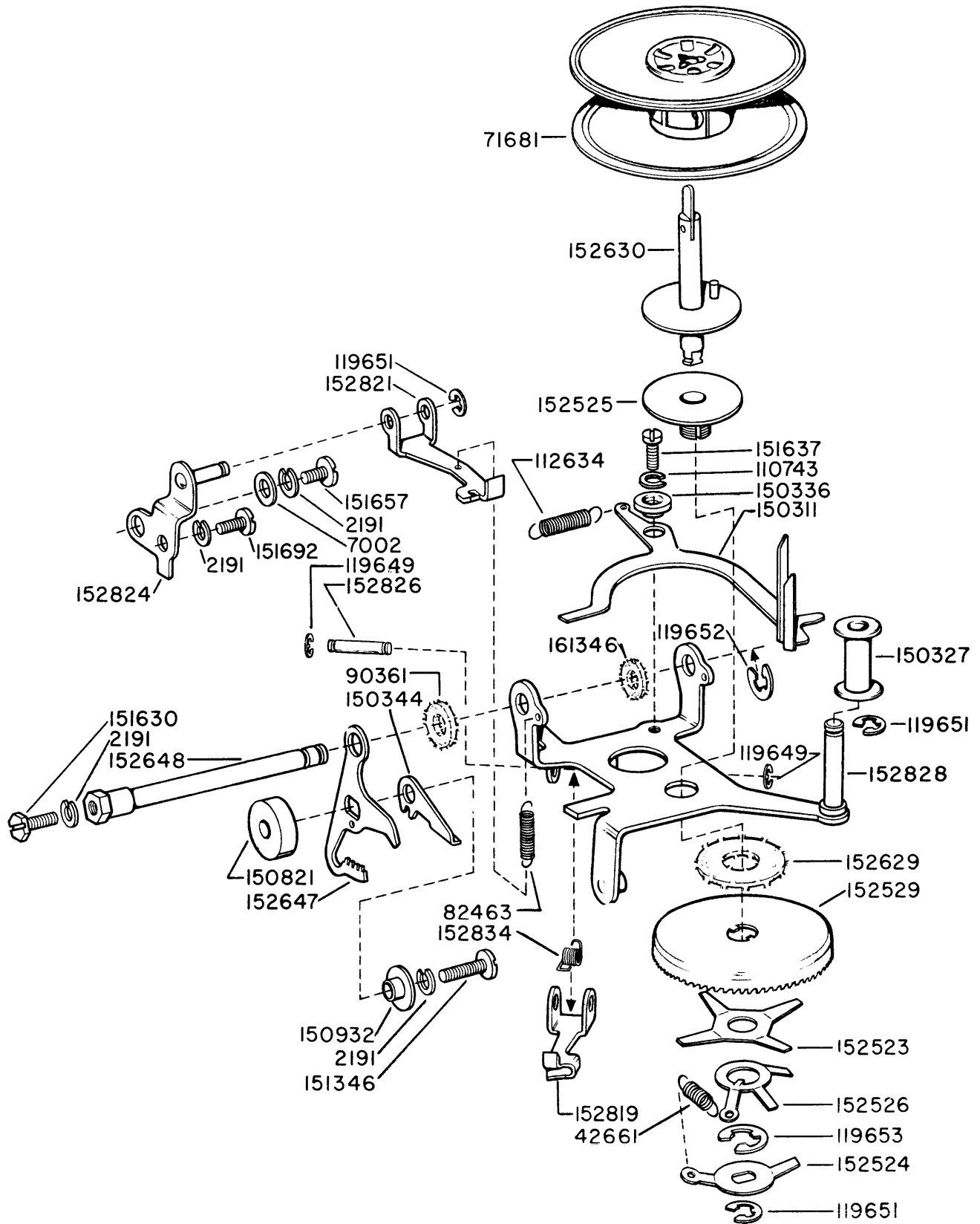
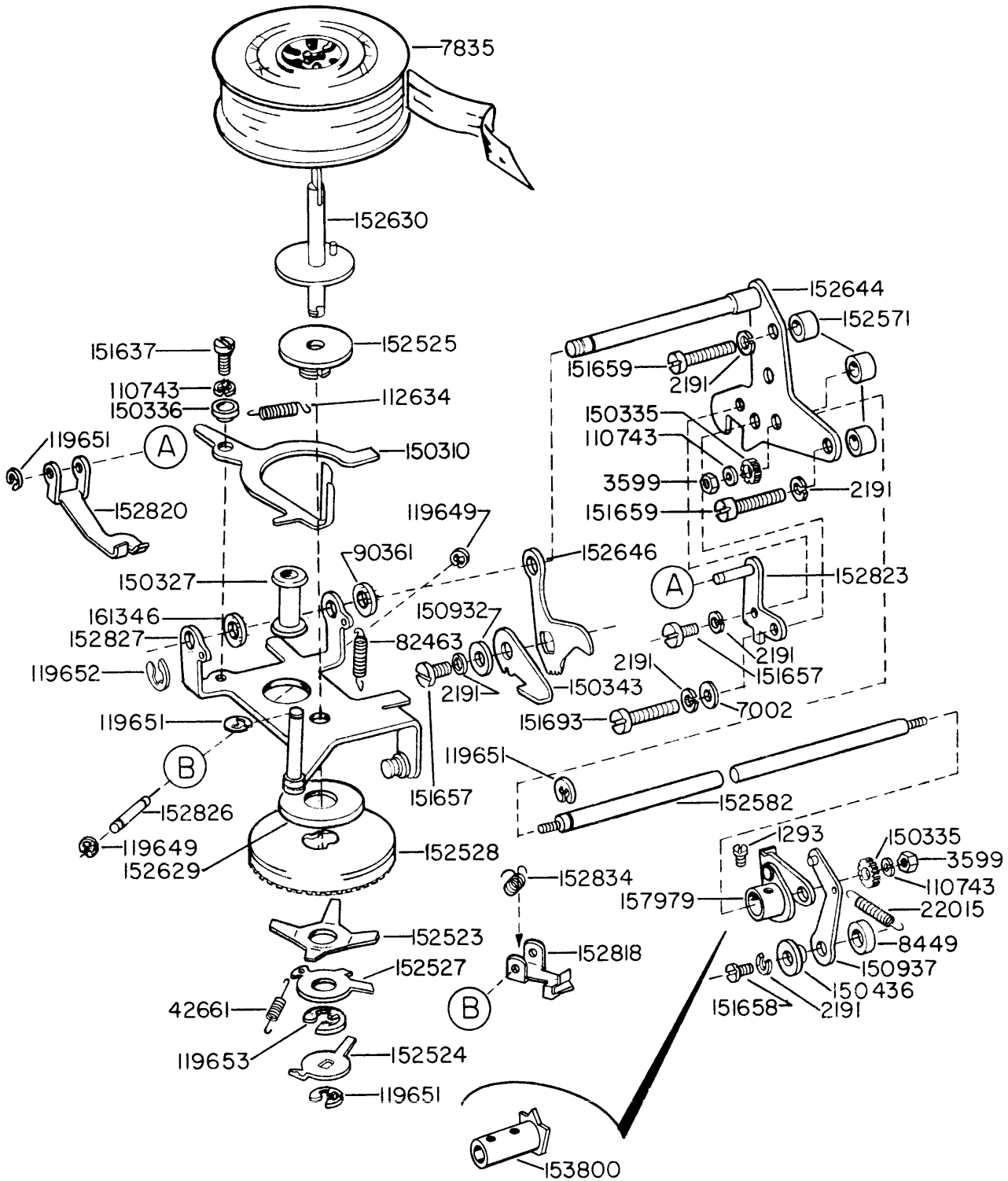


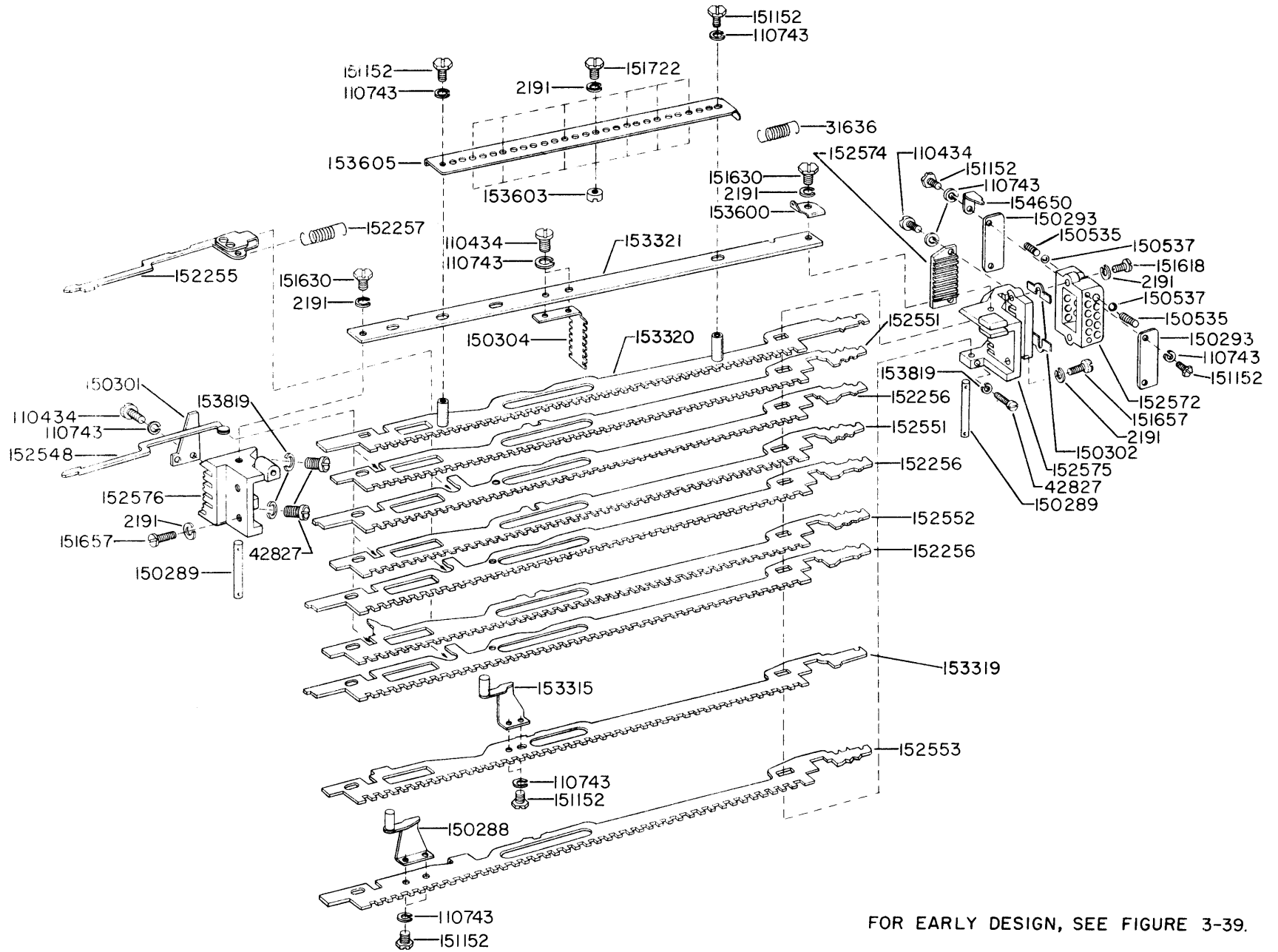
FIGURE 3-36 RIGHT RIBBON FEED MECHANISM



EARLY DESIGN CAM DETENT

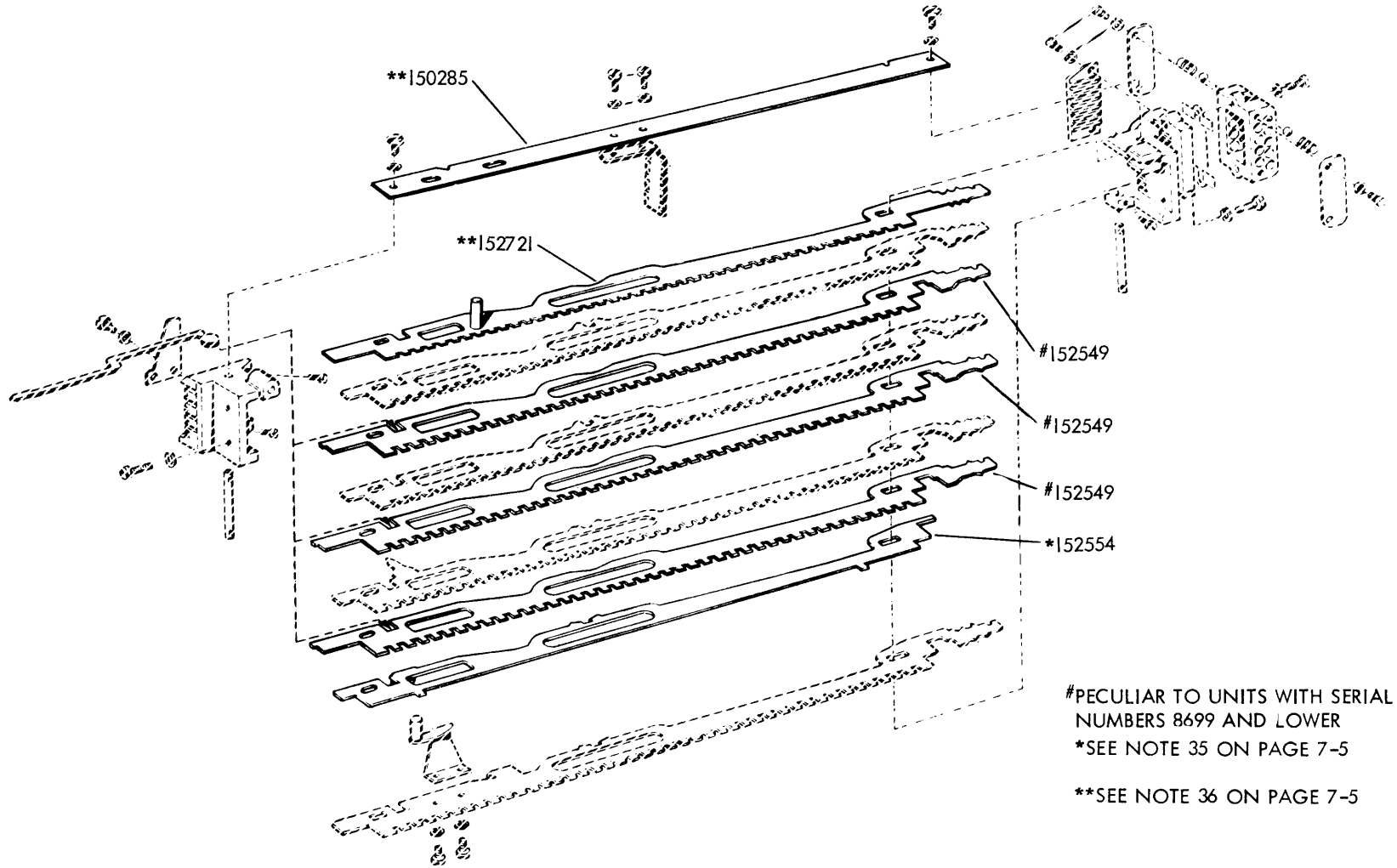
FIGURE 3-37. LEFT RIBBON FEED MECHANISM

FIGURE 3-38 CODE BAR MECHANISM



11498

FOR EARLY DESIGN, SEE FIGURE 3-39.



#PECULIAR TO UNITS WITH SERIAL NUMBERS 8699 AND LOWER

\*SEE NOTE 35 ON PAGE 7-5

\*\*SEE NOTE 36 ON PAGE 7-5

EARLY DESIGN PARTS

FIGURE 3-39. CODE BAR MECHANISM

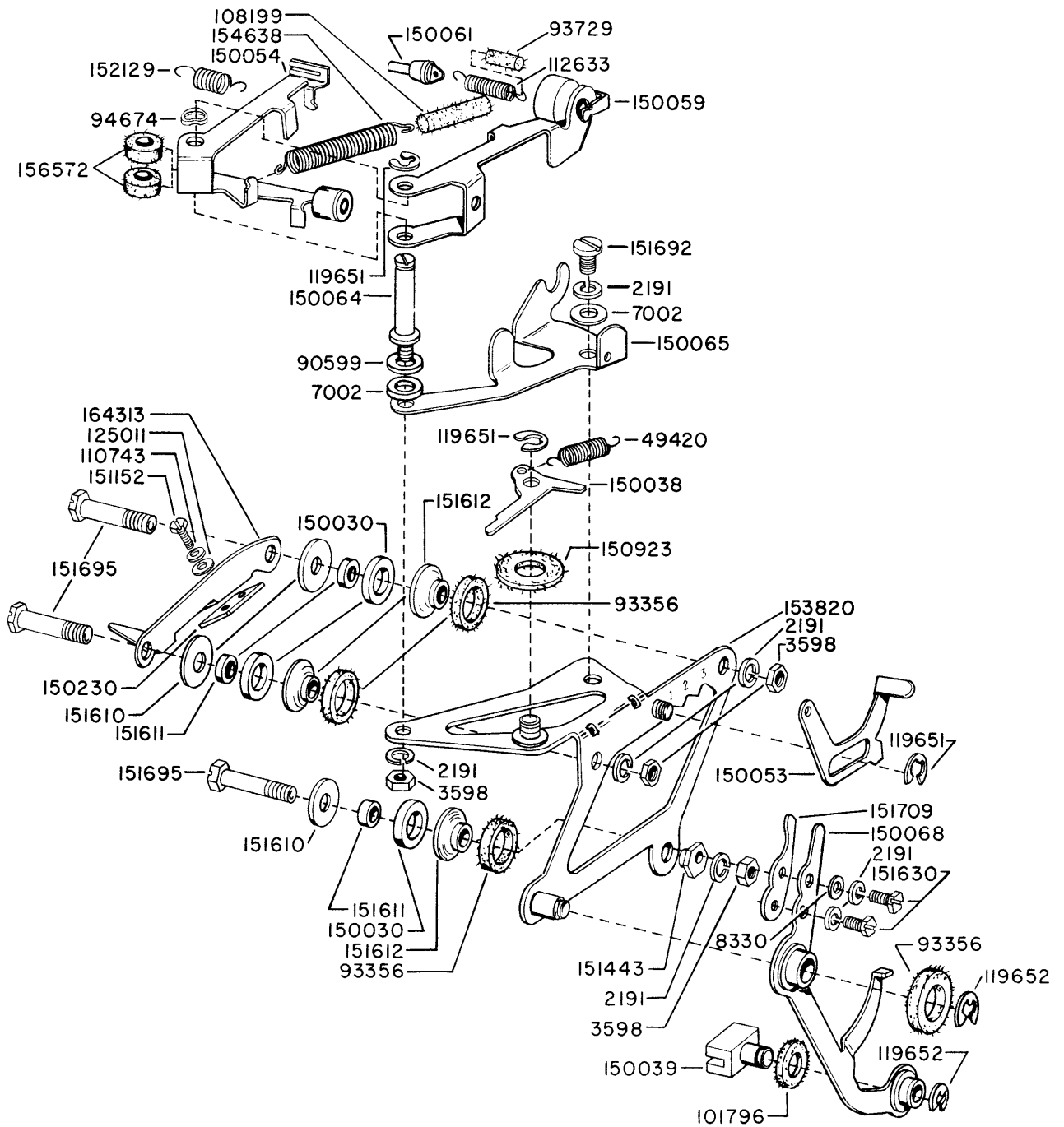
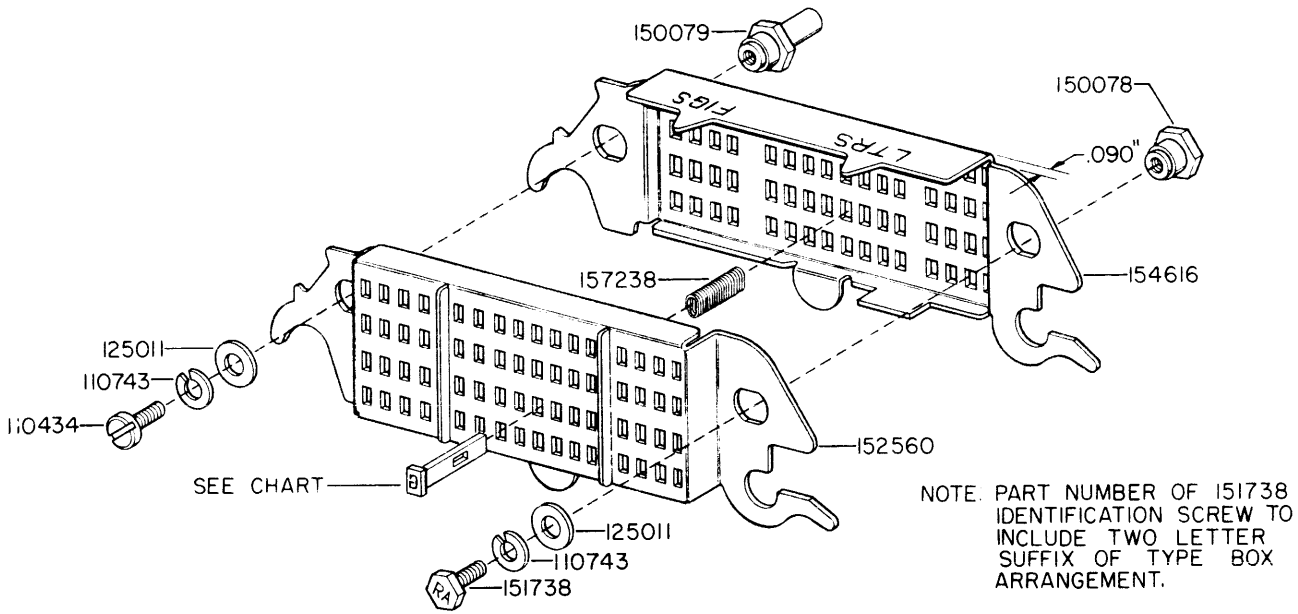


FIGURE 3-40 PRINTING CARRIAGE MECHANISM

1149B



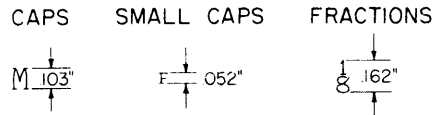
MURRAY STYLE PALLETS

PALLET	NUMBER	PALLET	NUMBER
A	157600	S	157618
B	157601	T	157619
C	157602	U	157620
D	157603	V	157621
E	157604	W	157622
F	157605	X	157623
G	157606	Y	157624
H	157607	Z	157625
I	157608	1	157626
J	157609	2	157627
K	157610	3	157628
L	157611	4	157629
M	157612	5	157630
N	157613	6	157631
O	157614	7	157632
P	157615	8	157633
Q	157616	9	157634
R	157617	-	157642

THE ABOVE PALLETS ARE COMMON TO ALL MURRAY STYLE ARRANGEMENTS

SEE PAGES 3-44 AND 3-45 FOR PALLET ARRANGEMENTS.

MURRAY STYLE PALLETS  
(10 CHARACTERS PER INCH SPACING)



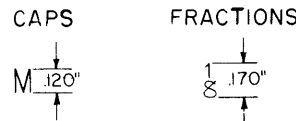
GOthic STYLE PALLETS  
(10 OR 12 CHARACTERS PER INCH SPACING)



LARGE GOthic STYLE PALLETS  
(5, 6 OR 8 CHARACTERS PER INCH SPACING)



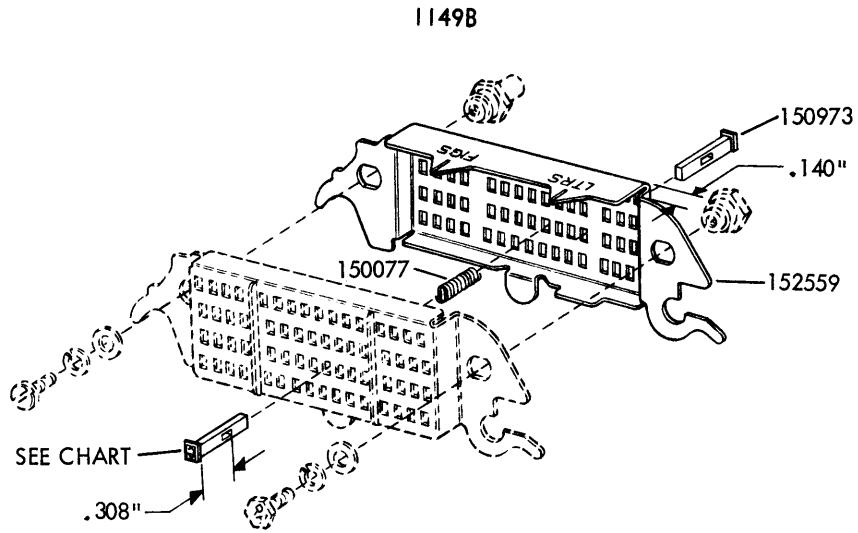
LONG GOthic STYLE PALLETS  
(10 CHARACTERS PER INCH SPACING)



FOR EARLY DESIGN, SEE FIGURE 3-42.

FIGURE 3-41. TYPE BOX AND PALLETS





MURRAY STYLE PALLETS

PALLET NUMBER	PALLET NUMBER	PALLET NUMBER	PALLET NUMBER
A 150100	X 150123	! 150146	↘ 151947
B 150101	Y 150124	& 150147	↙ 151948
C 150102	Z 150125	; 150148	+ 151949
D 150103	1 150126	/ 150149	○ 151950
E 150104	2 150127	▼ 150150	⊙ 151951
F 150105	3 150128	150151	⊕ 151952
G 150106	4 150129	150152	⊗ 151953
H 150107	5 150130	150153	X 154536
I 150108	6 150131	150154	Ñ 154537
J 150109	7 150132	150155	∞ 154538
K 150110	8 150133	150156	Δ 154539
L 150111	9 150134	150157	⊞ 154540
M 150112	— 150143	¢ 150158	□ 154541
N 150113	. 150135	# 150159	⊞ 154542
O 150114	, 150136	% 150160	⊞ 154543
P 150115	" 150137	∞ 150161	∧ 154544
Q 150116	( 150138	* 150162	∨ 154545
R 150117	? 150139	← 151941	⊞ 154546
S 150118	∅ 150140	→ 151942	@ 154547
T 150119	) 150141	↓ 151943	154548
U 150120	£ 150142	↑ 151944	° 154549
V 150121	\$ 150144	↘ 151945	BLANK 150973
W 150122	: 150145	↙ 151946	

SEE NOTE 37 ON PAGE 7-5

FIGURE 3-42. EARLY DESIGN TYPE BOX AND PALLETS



**\*GOTHIC STYLE PALLETS  
(12-TO-INCH SPACING)**

PALLET	NUMBER	155705 "XD"	155706 "XE"	155707 "XF"	161362 "XR"	161363 "XS"	161364 "XT"	161365 "XU"	162056 "XZ"
		&	155467	X	X	X	X	X	X
\$	155468	X	X	X	X	X	X	X	X
%	155470			X					X
2	155471	X	X		X	X			
4	155472	X	X		X	X			
#	155473	X	X		X	X			X
8	155474	X			X	X			
5	155475	X			X	X			
8	155476	X			X	X			
3	155477	X			X	X			
3	155478	X			X	X			
+	155479							X	
,	157637	X	X	X	X	X	X	X	X
"	157638	X	X	X	X	X	X	X	X
'	157639	X			X	X			X
;	157640	X	X	X					X
:	157641	X	X	X					
?	157644	X	X	X					
)	157645	X			X				X
(	157646	X	X	X					X
!	157647			X					
←	161366							X	
→	161367							X	
↓	161368							X	
↑	161369						X		
↖	161370						X		
↗	161371						X		
↘	161372						X		
↙	161373						X		
O	161374						X		
0	161375						X		
0	161376						X		
0	161377						X		

THE PALLETS LISTED BELOW ARE COMMON TO ALL GOTHIC STYLE ARRANGEMENTS (12-TO-INCH SPACING)

PALLET	NUMBER	PALLET	NUMBER
A	155432	T	155451
B	155433	U	155452
C	155434	V	155453
D	155435	W	155454
E	155436	X	155455
F	155437	Y	155456
G	155438	Z	155457
H	155439	1	155458
I	155440	2	155459
J	155441	3	155460
K	155442	4	155461
L	155443	5	155462
M	155444	6	155463
N	155445	7	155464
O	155446	8	155465
P	155447	9	155466
Q	155448	/	155469
R	155449	.	157636
S	155450	-	157642

\*USED WITH 154792 MOD. KIT (SEE FIGURE 3-79)

**\*LARGE GOTHIC STYLE PALLETS**

PALLET	NUMBER	154643 "RV"	153518 "WA"	160755 "XM"	160999 "XP"	163295 "YC"	161081 "YG"	164218 "YJ"	164348 "YK"
		∅	157764	X	X				
,	157766	X	X	X	X	X	X	X	X
"	157767	X	X	X	X	X	X	X	X
'	157768	X	X				X	X	X
;	157769	X	X				X	X	
:	157770	X	X				X	X	
-	157771	X	X	X	X	X	X	X	X
?	157773	X	X				X	X	
(	157774	X	X				X	X	
)	157775	X	X				X	X	
!	157776	X	X					X	
#	157779	X	X	X			X	X	X
1	157823		X	X					
1	157824		X	X					
3	157825		X	X					
1	157826		X	X					
5	157827		X	X					
3	157828		X	X					
7	157829		X	X					
1	163308						X	X	
4	163309						X	X	
3	163310						X	X	
1	163311						X	X	
5	163312						X	X	
3	163313						X	X	
7	163314						X	X	

THE PALLETS LISTED BELOW ARE COMMON TO ALL LARGE GOTHIC STYLE ARRANGEMENTS

PALLET	NUMBER	PALLET	NUMBER
A	157729	U	157749
B	157730	V	157750
C	157731	W	157751
D	157732	X	157752
E	157733	Y	157753
F	157734	Z	157754
G	157735	1	157755
H	157736	2	157756
I	157737	3	157757
J	157738	4	157758
K	157739	5	157759
L	157740	6	157760
M	157741	7	157761
N	157742	8	157762
O	157743	9	157763
P	157744	.	157765
Q	157745	/	157772
R	157746	\$	157777
S	157747	&	157778
T	157748		

\*USED WITH 154755 OR 159395 MOD. KIT (SEE FIGURES 3-77 AND 3-78)

**LONG GOTHIC STYLE PALLETS**

PALLET	NUMBER	155693 "WP"	155709 "XH"	162058 "YA"
		:	155654	X
(	155657	X	X	
)	155658	X	X	
0	155660	X		
0	155661	X		
0	155662	X		
→	155663	X		
*	155664	X		
∞	155665	X		
\$	155667		X	X
?	155668		X	
!	155669		X	
:	155670		X	
,	155671		X	
.	155672		X	X
"	155673		X	X
7	155885		X	
5	155886		X	
1	155887		X	
3	155888		X	
1	155889		X	
3	155890		X	
1	155891		X	

THE PALLETS LISTED BELOW ARE COMMON TO ALL LONG GOTHIC STYLE ARRANGEMENTS

PALLET	NUMBER	PALLET	NUMBER
A	155618	U	155638
B	155619	V	155639
C	155620	W	155640
D	155621	X	155641
E	155622	Y	155642
F	155623	Z	155643
G	155624	1	155644
H	155625	2	155645
I	155626	3	155646
J	155627	4	155647
K	155628	5	155648
L	155629	6	155649
M	155630	7	155650
N	155631	8	155651
O	155632	9	155652
P	155633	'	155653
Q	155634	-	155655
R	155635	/	155656
S	155636	#	155659
T	155637	&	155666

TYPEPALLET CHART

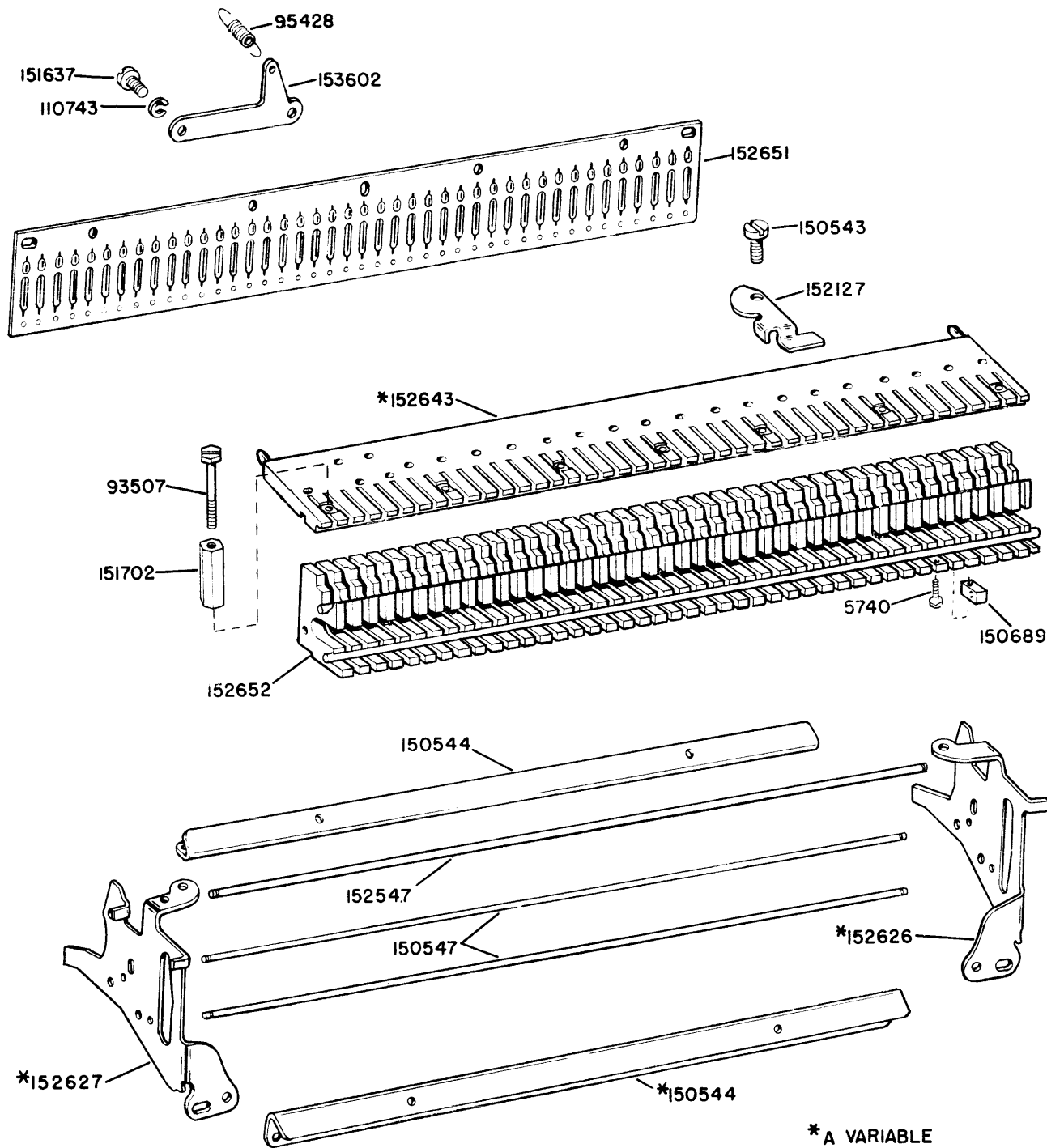
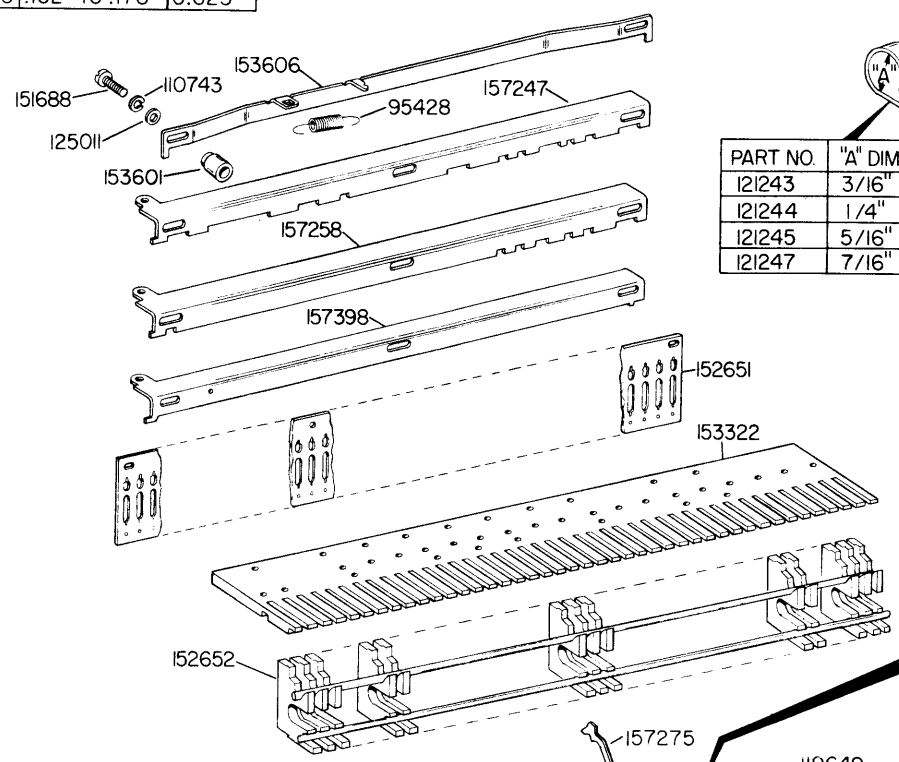
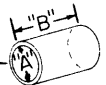


FIGURE 3-43. STUNT BOX—MAJOR COMPONENTS

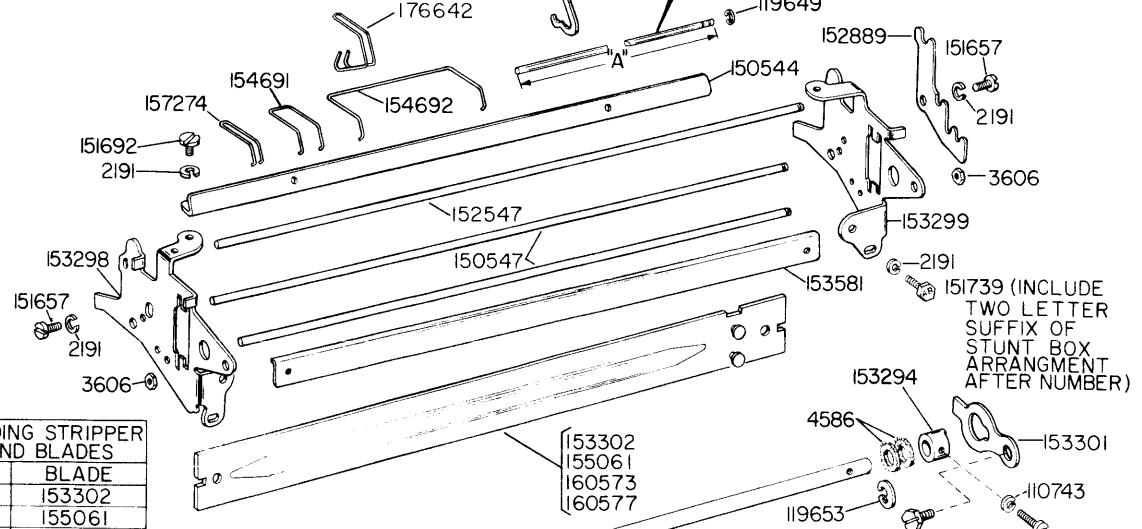
PART NO.	"A" DIM.	"B" DIM.
155750	.091" TO .101"	0.500"
155751	.114" TO .124"	1.000"
155752	.057" TO .067"	0.375"
155753	.114" TO .124"	0.500"
155754	.057" TO .067"	0.500"
155755	.162" TO .178"	0.625"



80342
125015

PART NO.	"A" DIM
121243	3/16"
121244	1/4"
121245	5/16"
121247	7/16"

PART NO.	"A" DIM.
153318	6.077
153838	1.062
154666	3.237
154667	2.796
154668	1.921
154669	5.640
155071	1.484
155072	3.890
155073	4.984
155074	7.390
155075	7.828
155076	2.139



CORRESPONDING STRIPPER SLIDES AND BLADES	
SLIDE	BLADE
153303	153302
155060	155061
160572	160573
160576	160577

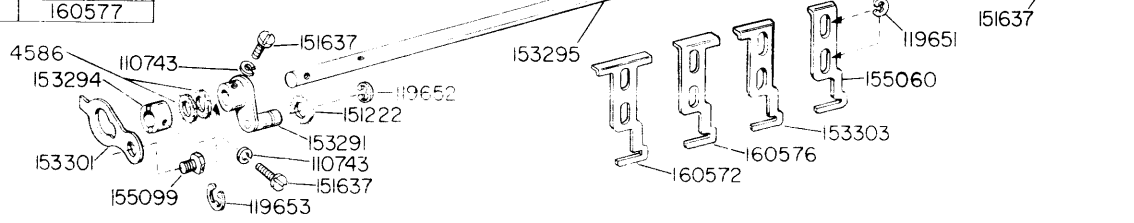


FIGURE 3-44 STUNT BOX-MAJOR COMPONENT VARIABLES

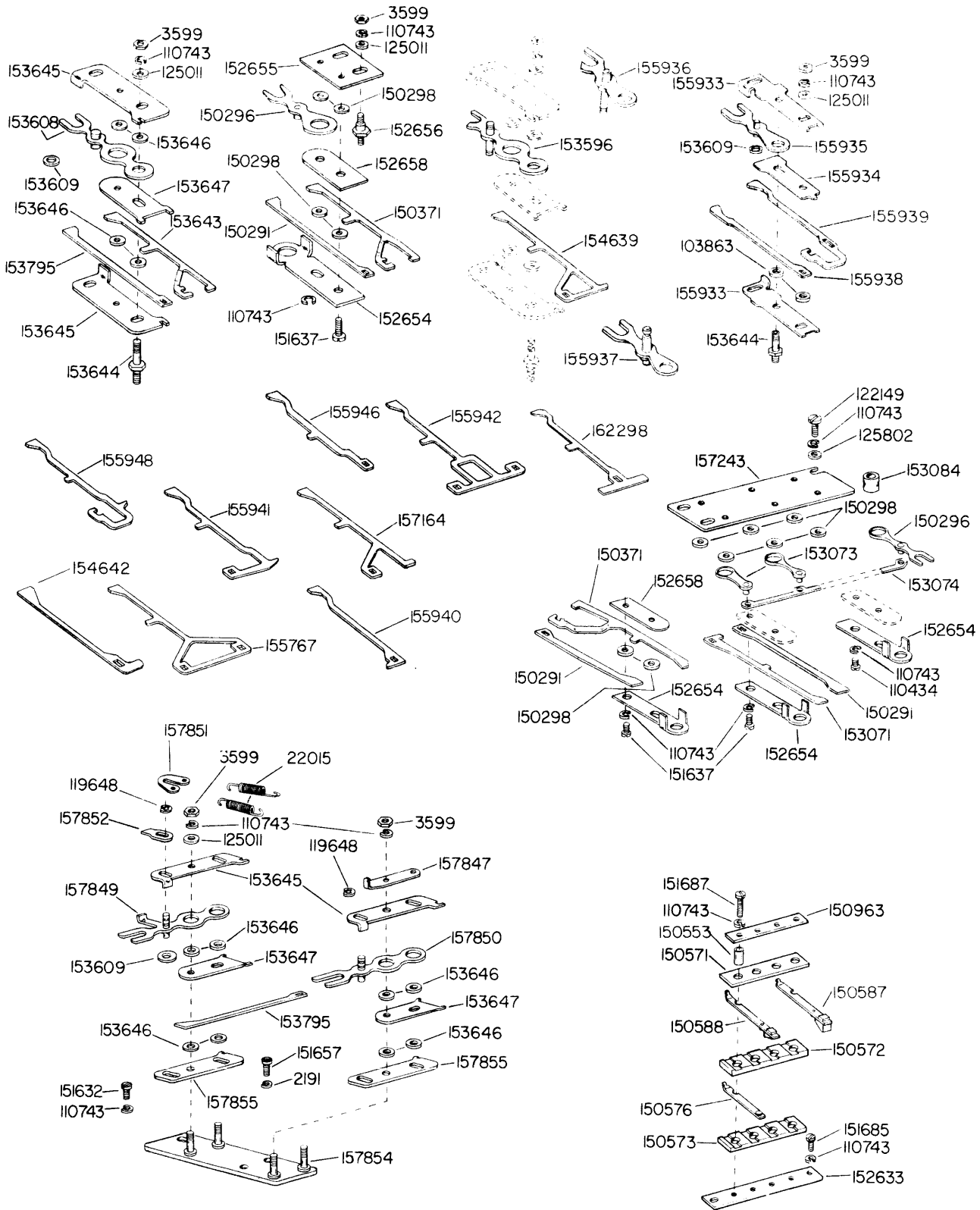


FIGURE 3-45. SHIFT MECHANISM COMPONENTS

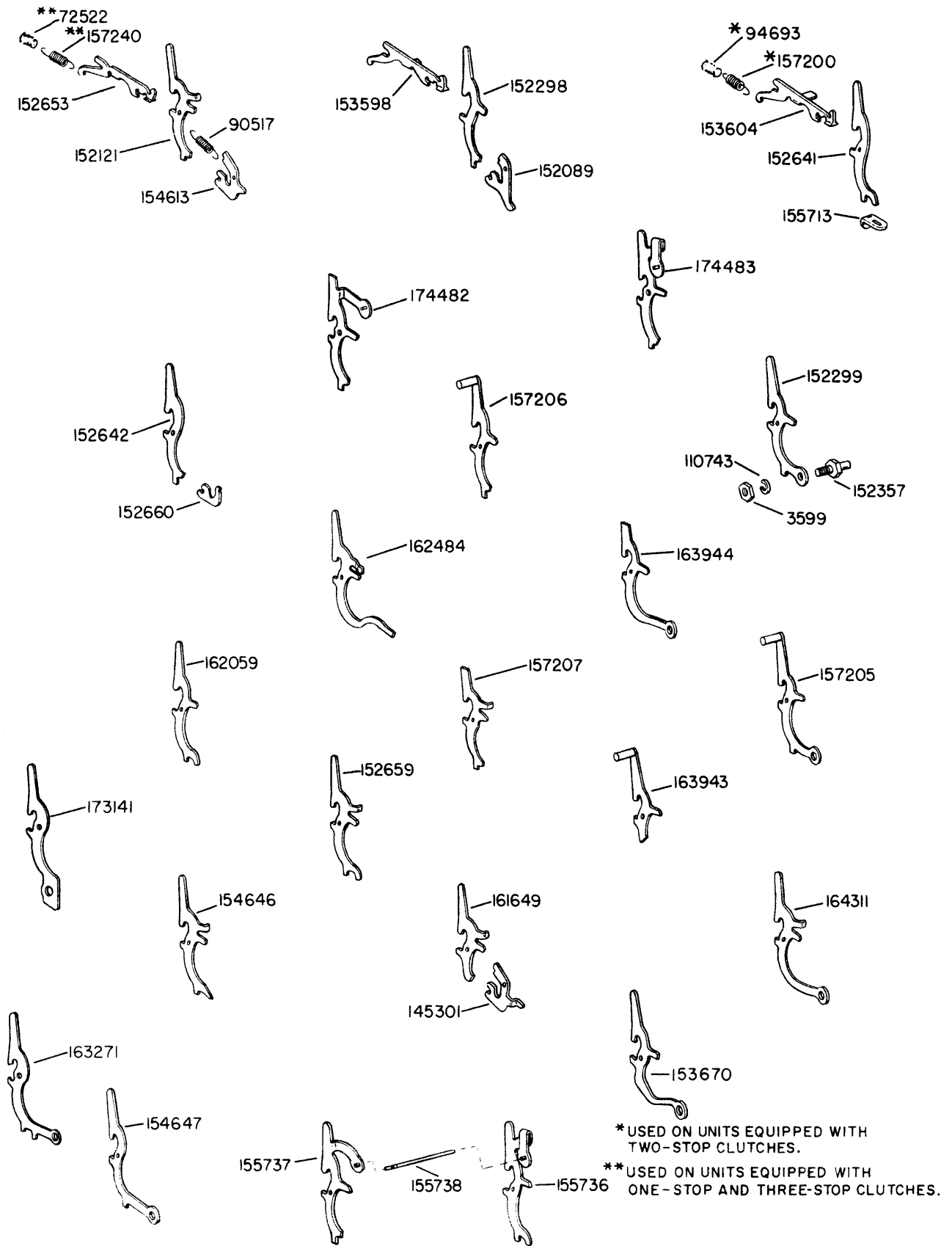
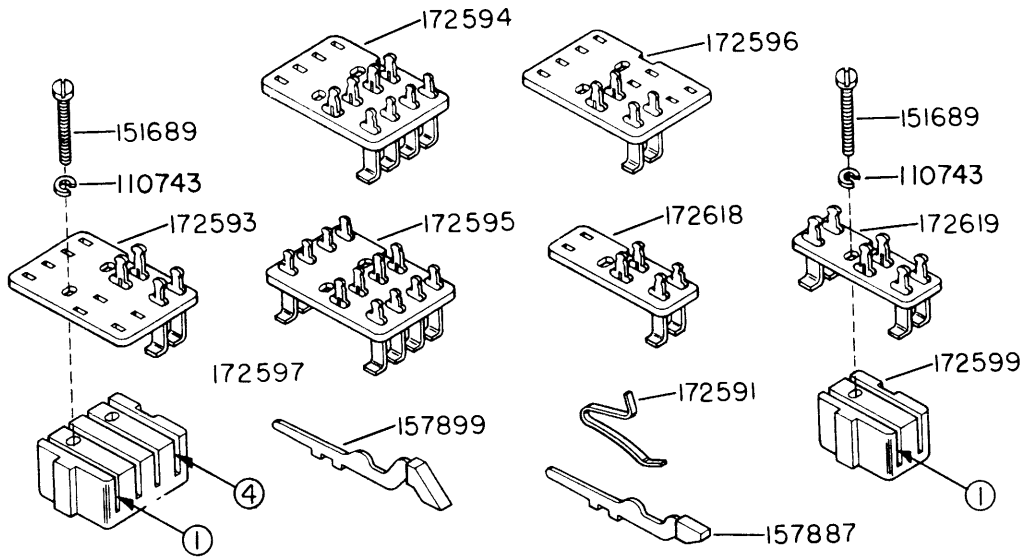


FIGURE 3-46. STUNT BOX—LATCHING COMPONENTS

1149B



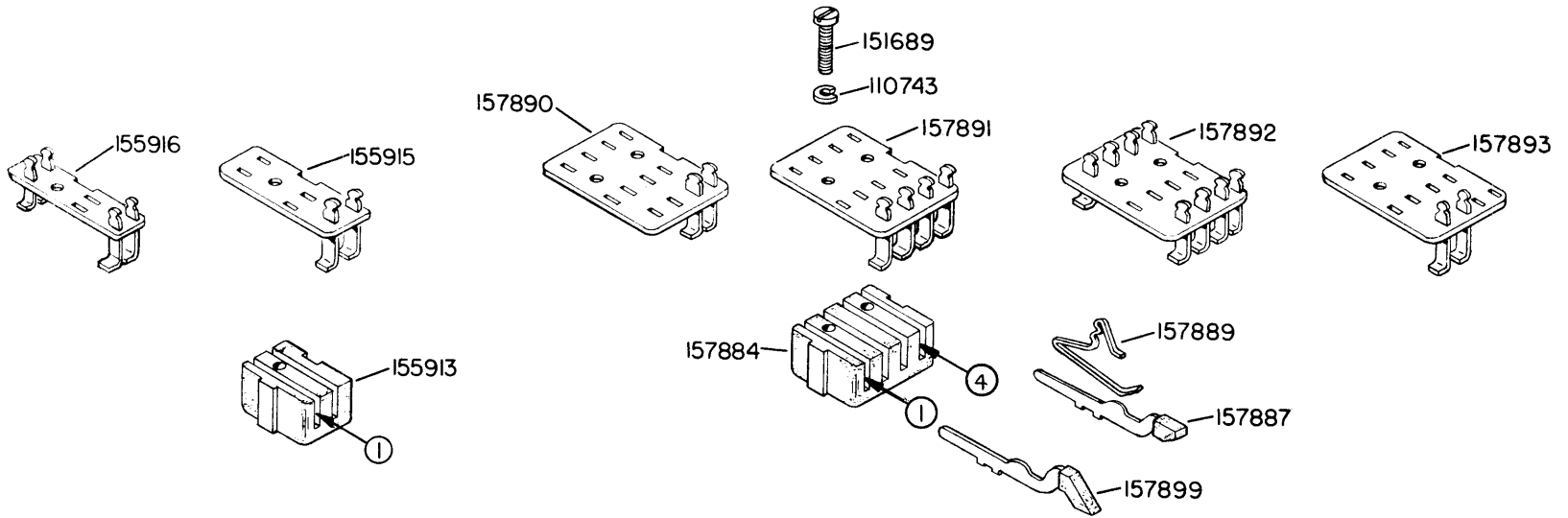
SWITCH ASSEMBLY NO.	CONTACT PLATE NO.	CONTACT ARM POSITION				SWITCH ASSEMBLY NO.	CONTACT PLATE NO.	CONTACT ARM POSITION			
		1	2	3	4			1	2	3	4
172500	172593			157887	157887	172546	172595	157899		157887	
172501	172593			157887		172547	172595	157887	157899	157887	
172502	172593				157887	172548	172596		157899		
172503	172594	157887	157899	157899	157887	172549	172595				157887
172504	172594	157887				172550	172595	157899			157899
172505	172594	157899			157899	172551	172594		157887	157887	157887
172506	172594		157887			172552	172594	157899		157887	157887
172507	172594	157899				172553	172595		157887	157899	
172508	172594	157887	157899			172554	172594		157899		157899
172509	172594	157899		157899		172555	172595	157899	157887	157899	157899
172510	172594	157899		157899	157887	172556	172595	157887	157887		157887
172511	172594	157899	157899	157899	157899	172557	172594	157887		157887	157887
172512	172594	157887	157887	157899		172558	172595	157899			
172513	172593			157899		172559	172594	157899	157887		
172514	172594	157887	157887	157887	157887	172560	172595	157899	157899	157887	157887
172515	172594	157887	157887	157887		172561	172594		157887	157899	
172516	172594		157887		157887	172562	172594			157899	
172517	172594	157899	157887	157899	157887	172563	172594	157887	157899	157887	157899
172518	172594		157887	157899	157887	172564	172594	157899	157887		157899
172519	172594	157899			157887						
172520	172594	157899		157887	157899						
172521	172593				157899						
172522	172594	157887	157899		157887						
172523	172594	157899	157887	157887	157899						
172524	172594	157887			157887						
172525	172595	157887	157887	157887	157887						
172526	172596		157887								
172527	172595			157887							
172528	172595	157887		157887							
172529	172595			157887	157887						
172530	172595	157887	157887	157887							
172531	172595	157887		157887	157887						
172532	172595	157887									
172533	172595	157887	157887								
172534	172594		157899	157887							
172535	172594			157899	157887						
172536	172594	157899	157887	157899							
172538	172595		157887	157887	157887						
172539	172595		157887		157887						
172540	172594		157899	157887	157887						
172541	172594	157899	157887	157887	157887						
172542	172594	157887	157899	157887	157887						
172543	172594	157889		157887							
172544	172595		157899		157887						
172545	172595	157899		157899							

FOR EARLY DESIGN, SEE FIGURE 3-48

FIGURE 3-47. SWITCH ASSEMBLIES AND COMPONENTS



FIGURE 3-48. SWITCH ASSEMBLIES AND COMPONENTS



SWITCH ASSEMBLY NO.	CONTACT PLATE NO.	CONTACT ARM POSITION		SWITCH ASSEMBLY NO.	CONTACT PLATE NO.	CONTACT ARM POSITION				SWITCH ASSEMBLY NO.	CONTACT PLATE NO.	CONTACT ARM POSITION			
		1	2			1	2	3	4			1	2	3	4
155917	155915	157887		157070	157890			157887	157887	160192	157892	157887		157887	157887
155918	155915		157887	157071	157890				157887	160193	157892	157887			
155919	155915	157887	157887	157072	157890					160194	157892	157887	157887		
155920	155916	157887		157073	157891	157887	157899	157899	157887	160195	157891		157899	157887	
155921	155916		157887	157074	157891	157887				160196	157891			157899	157887
155922	155916	157887	157887	157075	157891	157899			157899	160197	157891	157899	157887	157899	157887
155923	155915	157899	157899	157076	157891		157887			160198	157891		157899	157887	
155924	155915	157899	157899	157077	157891	157899				160199	157892		157887	157887	157887
155925				157078	157891	157887	157899			160200	157892		157887		157887
155926				157079	157891	157899		157899		160201	157891		157899	157887	157887
155927				157080	157891	157899		157899	157887	160202	157891	157899	157887	157887	157887
155928				157081	157891	157899	157899	157899	157899	160203	157891	157887	157899	157887	157887
155929				157082	157891	157887	157887	157899		160204	157891	157899	157887		
				157083	157890			157899		160205	157892		157899		157887
				157084	157891	157887	157887	157887	157887	160206	157892	157899		157899	
				157085	157891	157887	157887	157887		160207	157892	157899		157887	
				157086	157891		157887		157887	160208	157892	157887	157899	157887	
				157087	157891	157899	157887	157899	157887	160209	157893		157899		
				157088	157891		157887	157899	157887	160210	157892				157887
				157089	157891	157899			157887	160211	157892	157899			157899
				157090	157891	157899		157887	157899	160212	157891	157899	157887	157887	157887
				157091	157890				157899	160213	157891	157899		157887	157887
				157092	157891	157887	157899		157887	160214	157892		157887	157899	
				157093	157891	157899	157887	157887	157899	160215	157891		157887	157899	
				157094	157891	157887			157887	160216	157892	157899	157887	157899	157899
				157095	157892	157887	157887	157887	157887	160217	157892	157887	157887		157887
				157096	157893		157887			160218	157891	157887		157887	157887
				157097	157892			157887		160219	157892	157899	157899	157887	157887
				157098	157892	157887		157887		160220	157891	157899	157887		
				157099	157892			157887	157887	160221					
				157100	157892	157887	157887	157887		160222					

SEE NOTE 38 ON PAGE 7-5

EARLY DESIGN PARTS

1149B

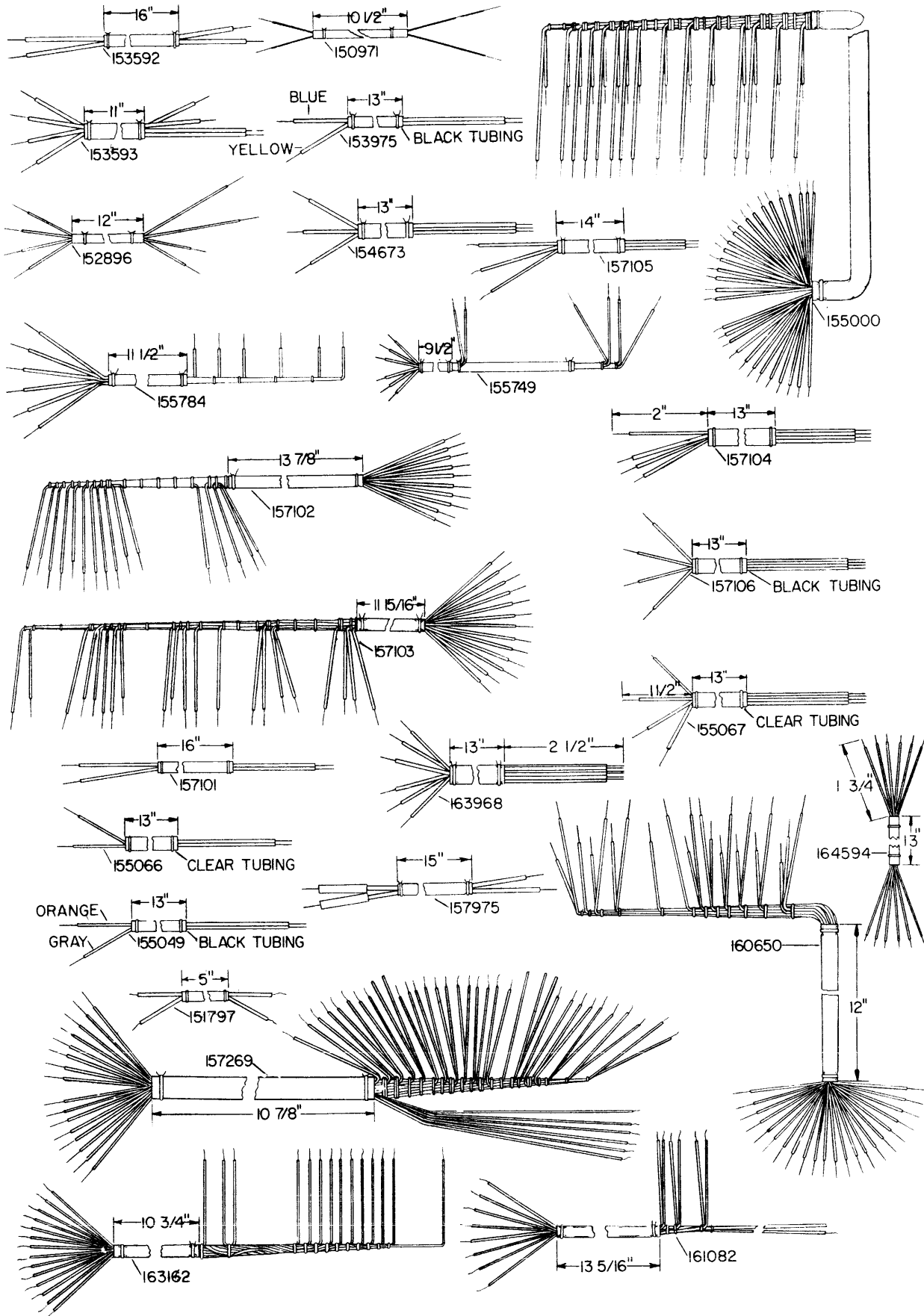
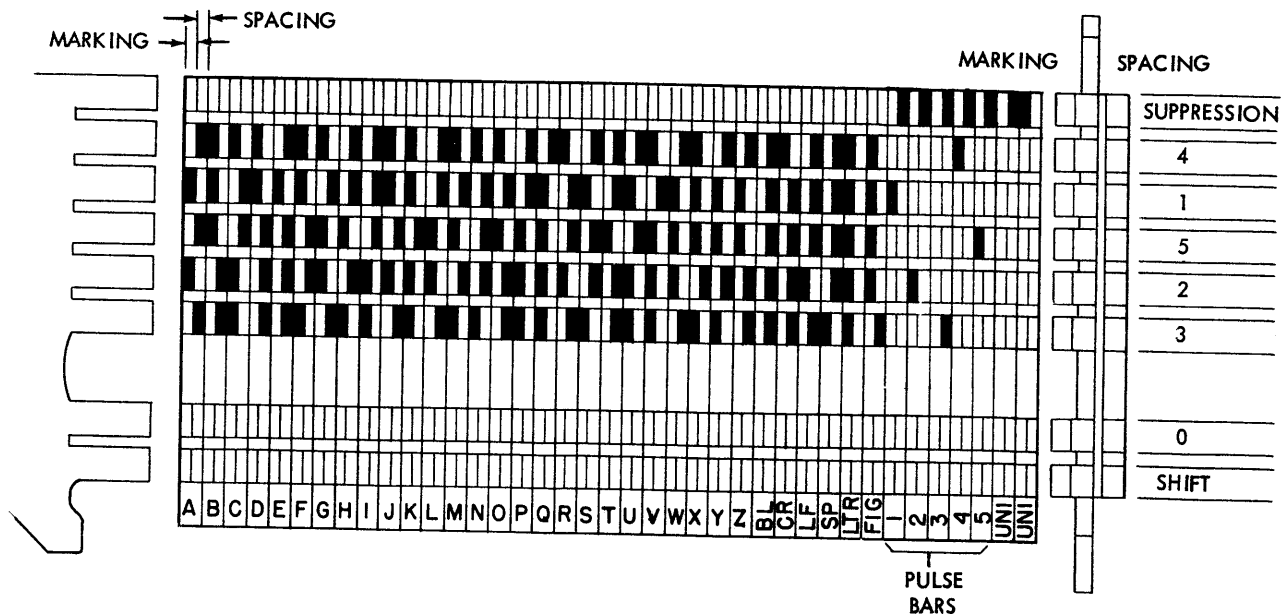


FIGURE 3-49 CABLE ASSEMBLIES

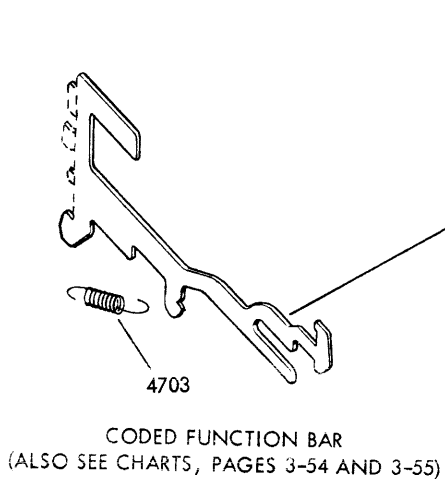


BLANK SQUARES INDICATE THE TINES THAT SHOULD BE REMOVED TO CODE THE 153440 FUNCTION BAR.

ADDITIONAL CODE BAR LEVELS AT WHICH THE FUNCTION BAR CAN BE CONTROLLED:

SUPPRESSION TINES	MARKING SPACING	NON-PRINT PRINT
0 TINES	MARKING SPACING	SELECT NON-SELECT
SHIFT TINES	MARKING SPACING	UPPER CASE LOWER CASE

THESE TERMS APPLY ONLY TO SELECTIVE CALLING



- 152665 — THROUGH — 152704
- 153160 — THROUGH — 153169
- 153409 — THROUGH — 153438
- 153520 — THROUGH — 153528
- 155100 — THROUGH — 155135
- 155141 — THROUGH — 155145
- 155176 — THROUGH — 155180
- 155191 — THROUGH — 155218
- 155246 — THROUGH — 155250
- 155286 — THROUGH — 155290
- 155296 — THROUGH — 155300
- 155306 — THROUGH — 155307
- 155311 — THROUGH — 155315
- 155326 — THROUGH — 155330
- 155336 — THROUGH — 155340
- 155366 — THROUGH — 155370
- 162636 — THROUGH — 162640

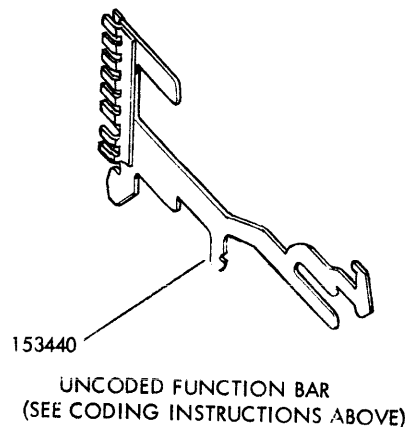
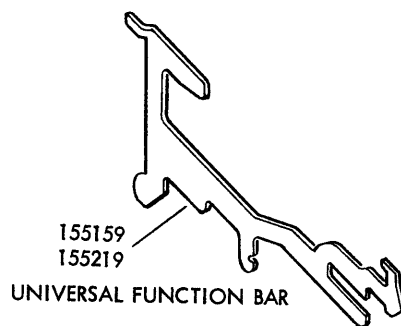
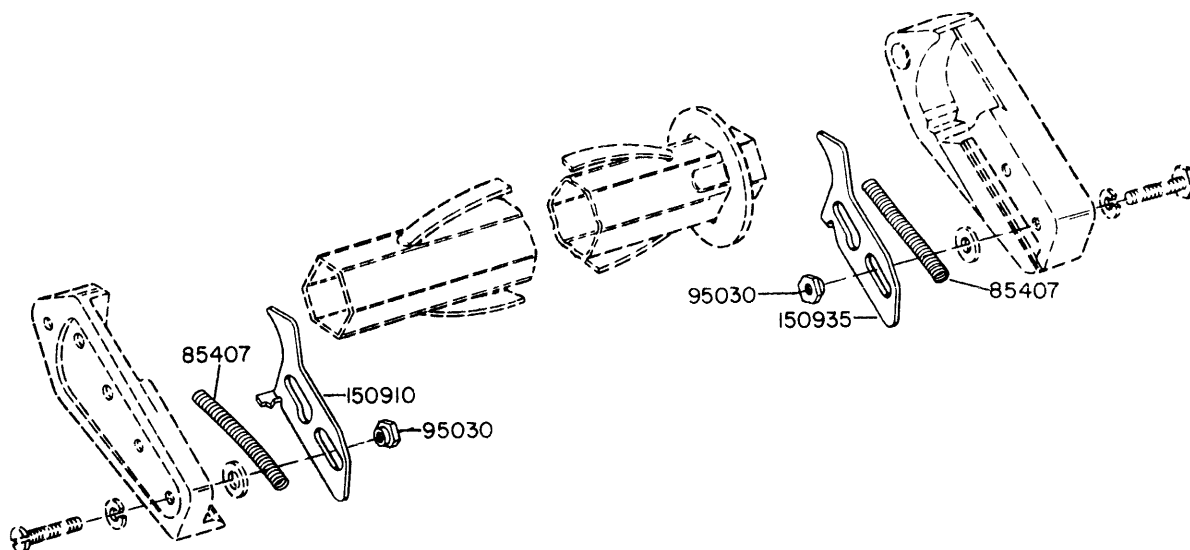


FIGURE 3-50. FUNCTION BARS

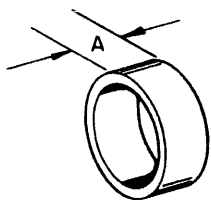
CONDITION OF TYPING UNIT FOR FUNCTION BAR SELECTION		NO RESTRICTIONS	UPPER CASE	LOWER CASE	SELECT	NON-SELECT	PRINT	NON-PRINT	CONDITION OF TYPING UNIT FOR FUNCTION BAR SELECTION
CHARACTER OR FUNCTION 153440 UNCODED FUNCTION BAR IS AVAILABLE FOR USE ON ANY CHAR- ACTER OR FUNCTION BY REMOVING TINES	A	152676			155100	153409	155191		A
	B	152677	153526		155101	153410	155192		B
	C	152678	153520		155102	153411	155193		C
	D	152679	153521		155103	153412	155194		D
	E	152680	153166		155104	153413	155195		E
	F	152681	153160	155326	155105	153414	155196	155286	F
	G	152682	153162	155327	155106	153415	155197	155287	G
	H	152683	152673	155328	155107	153416	155198	155288	H
	I	152684	155249	155329	155108	153417	155199	155289	I
	J	152685	152694	155330	155109	153418	155200	155290	J
	K	152686			155110	153419	155201		K
	L	152687	153522		155111	153420	155202		L
	M	152688	152674		155112	153421	155203		M
	N	152689	153523		155113	153422	155204		N
	O	152690	153528		155114	153423	155205		O
	P	152691	155250	155336	155115	153424	155206	155296	P
	Q	152692	153165	155337	155116	153425	155207	155297	Q
	R	152695	153167	155338	155117	153426	155208	155298	R
	S	152696	152672	155339	155118	153427	155209	155299	S
	T	152697	153524	153169	155119	153428	155210	155300	T
	U	152698	155248	155340	155120	153429	155211		U
	V	152699	153164		155121	153430	155212		V
	W	152700	153163		155122	153431	155213		W
	X	152701	153525		155123	153432	155214		X
	Y	152702	153527		155124	153433	155215		Y
	Z	152703	153161		155125	153434	155216	155306	Z
		152669	152693	152675	155312		155217	155307	BLANK
		152665			155313		153438		LETTERS
	152666							FIGURES	
	155129			155314	152670			SPACE	
	152667			155128		155127		CARRIAGE-RETURN	
	152668			155315		153435	155130	LINE FEED	
	152704	153168		155311	152671			ANY CHARACTER OR FUNCTION	
				155132				M & N	
				155218				M & V	
						162636		PULSE #1	
						162637		" 2	
						162638		" 3	
						162639		" 4	
						162640		" 5	
						155159	155219	UNIV.	
POSITION OF FUNCTION BAR TINES	SUPPRESSION LEVEL ZERO LEVEL SHIFT LEVEL		MARKING	SPACING	MARK-ING	SPACING	MARKING	SUPPRESSION LEVEL ZERO LEVEL SHIFT LEVEL	

CONDITION OF TYPING UNIT FOR FUNCTION BAR SELECTION		PRINT NON-SELECT	PRINT UPPER CASE	PRINT SELECT	SELECT LOWER CASE	PRINT LOWER CASE	SELECT UPPER CASE	NON-SELECT LOWER CASE	CONDITION OF TYPING UNIT FOR FUNCTION BAR SELECTION
CHARACTER OR FUNCTION	A								A
	B								B
	C								C
	D								D
	E								E
	F		155141						F
	G		155135						G
	H		155142		155133				H
	I		155143						I
	J		155131						J
	K		155144						K
	L		155145						L
	M								M
	N								N
	O								O
	P					155176		155366	P
	Q					155177		155367	Q
	R					155178		155368	R
	S		153437			155179		155369	S
	T					155180		155370	T
	U								U
	V								V
	W								W
	X								X
	Y								Y
	Z		155134				155246	155247	Z
BLANK								BLANK	
LETTERS								LETTERS	
FIGURES								FIGURES	
SPACE								SPACE	
CARRIAGE-RETURN								CARRIAGE-RETURN	
LINE FEED								LINE FEED	
ANY CHARACTER OR FUNCTION		153436		155126				ANY CHARACTER OR FUNCTION	
M & N								M & N	
M & V								M & V	
PULSE #1								PULSE #1	
" 2								" 2	
" 3								" 3	
" 4								" 4	
" 5								" 5	
UNIV.								UNIV.	
POSITION OF FUNCTION BAR TINES	SUPPRESSION LEVEL ZERO LEVEL SHIFT LEVEL	SPACING SPACING	SPACING MARKING	SPACING MARKING	MARKING SPACING	SPACING SPACING	MARKING MARKING	SPACING SPACING	SUPPRESSION LEVEL ZERO LEVEL SHIFT LEVEL



SPECIFICATION 5767S

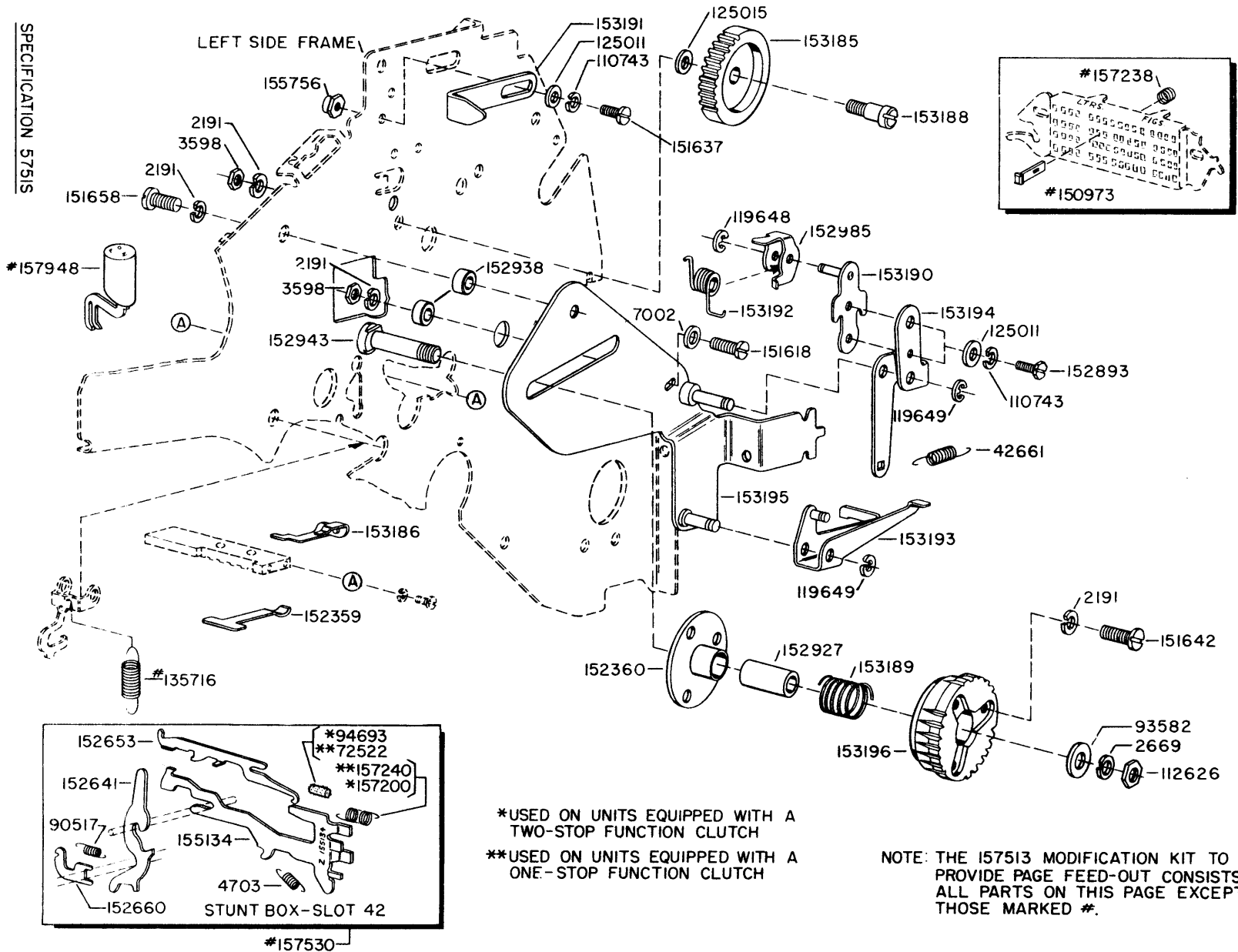
FIGURE 3-51 151799 MODIFICATION KIT TO PROVIDE LATCHES FOR PAPER SPINDLE



PART NO.	DIM "A"
155581	.250
155582	.500
155583	1.000
155584	2.000

FIGURE 3-52 159362 MODIFICATION KIT TO PROVIDE SPACERS FOR CENTERING NARROW PAPER ROLL ON SPINDLE

FIGURE 3-53. 152302 MODIFICATION KIT TO PROVIDE PAGE FEED-OUT ON UPPER CASE "Z"



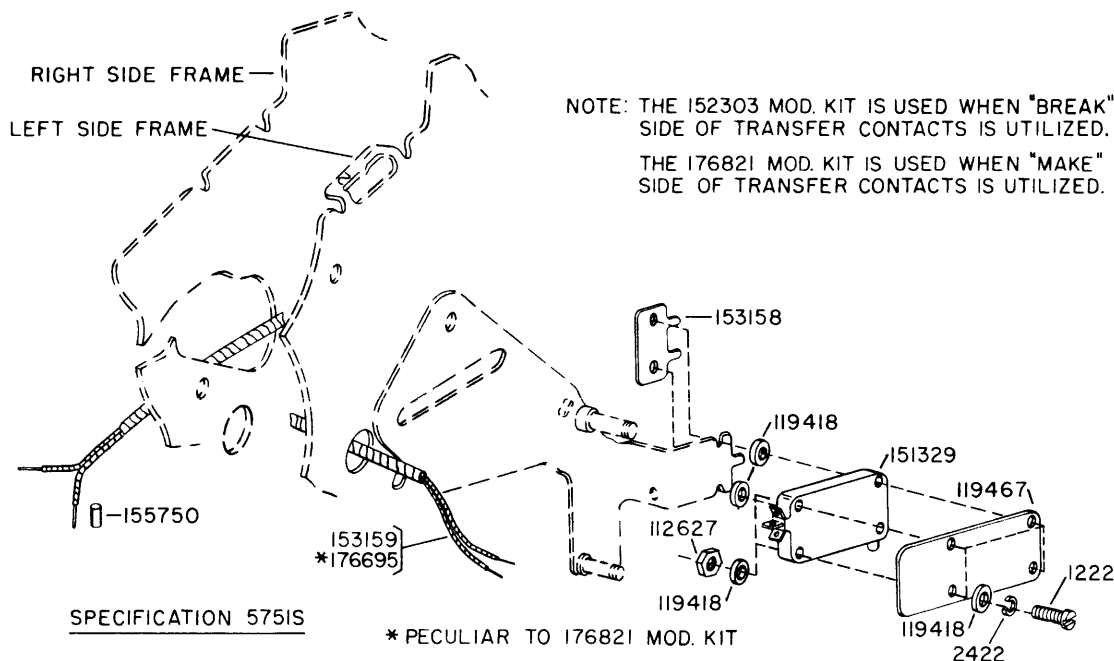


FIGURE 3-54. 152303 AND 176821 MODIFICATION KITS TO PROVIDE PAGE FEED-OUT TRANSMITTER CONTROL

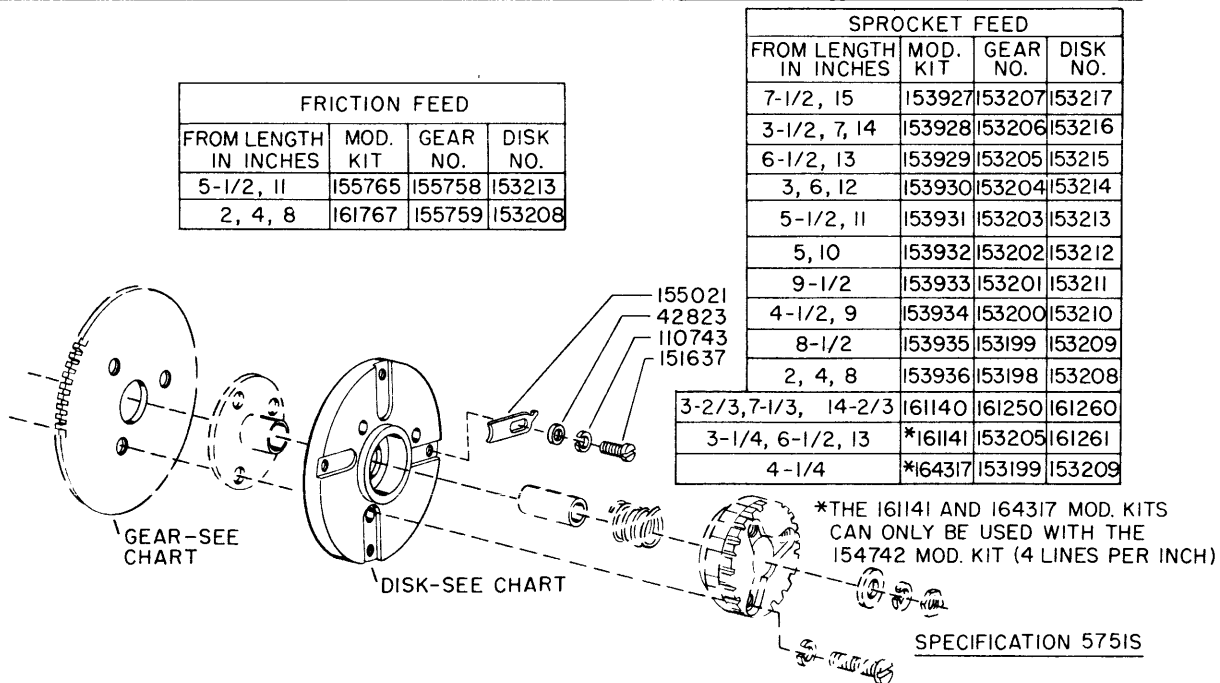
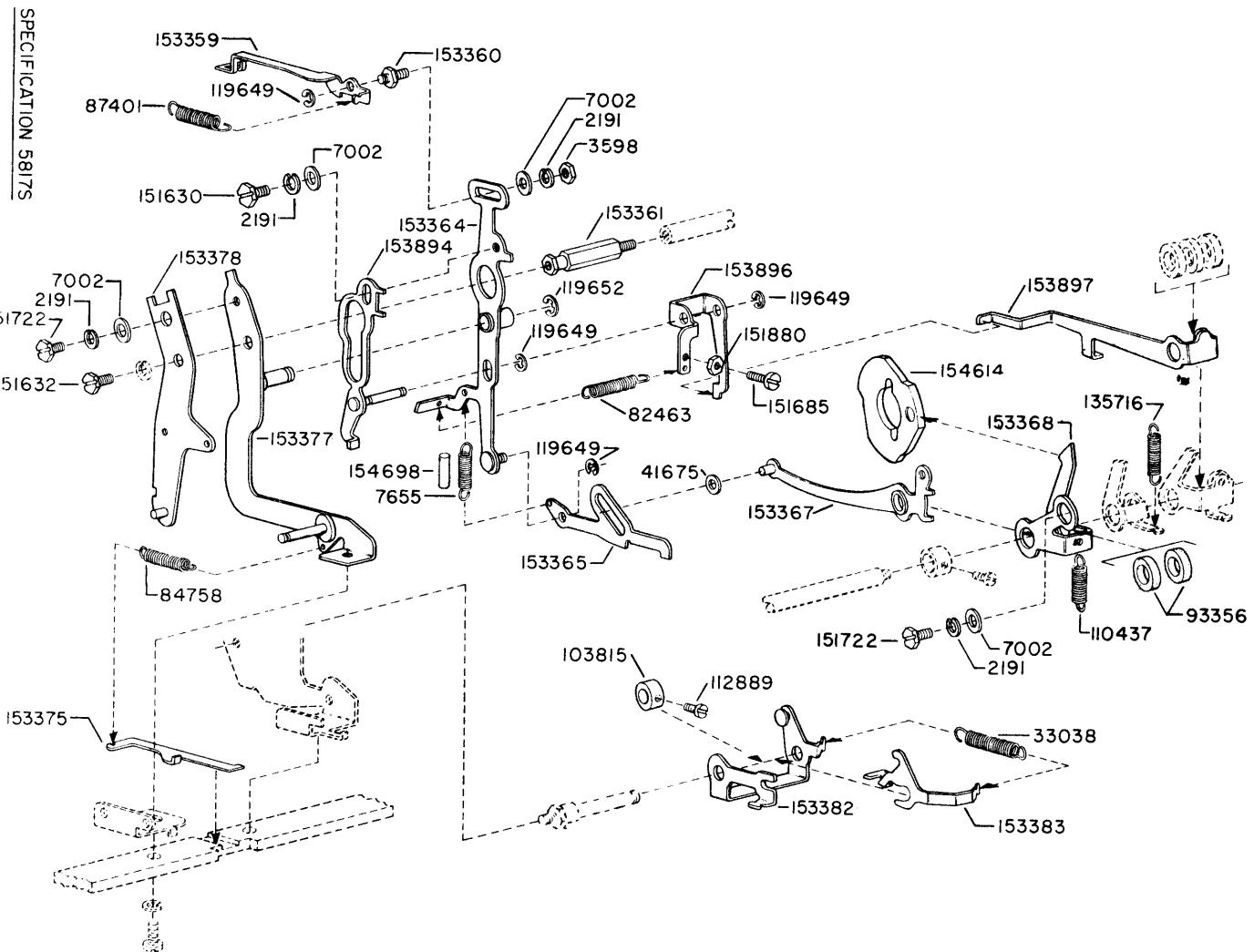


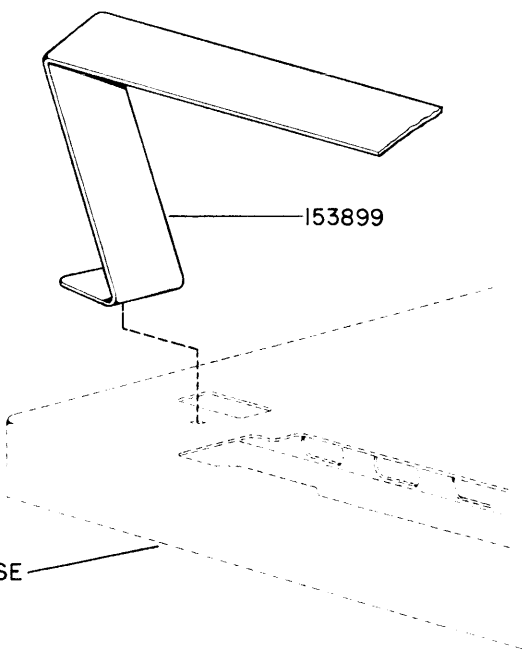
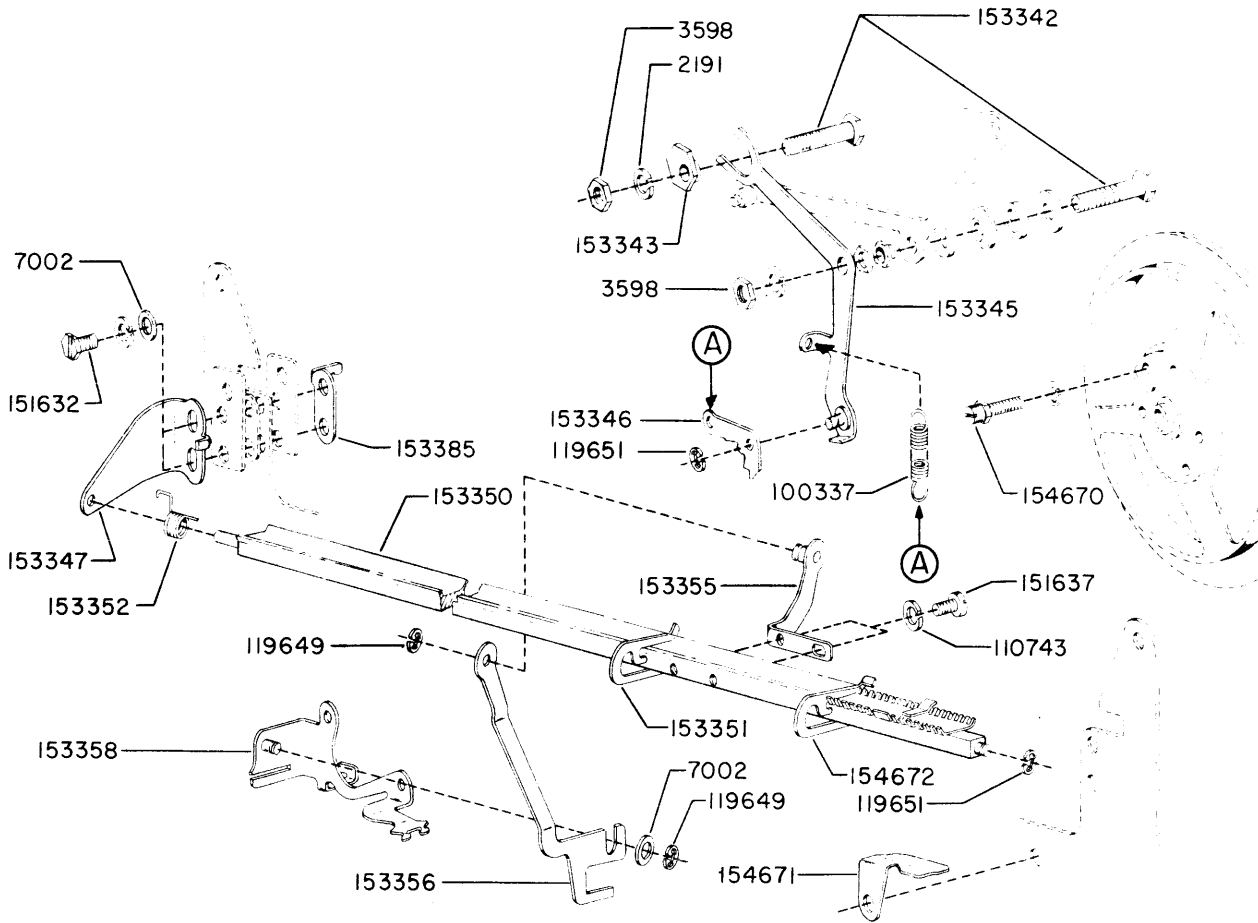
FIGURE 3-55 MODIFICATION KITS TO PROVIDE PAGE FEED-OUT FORM LENGTH GEAR AND DISK



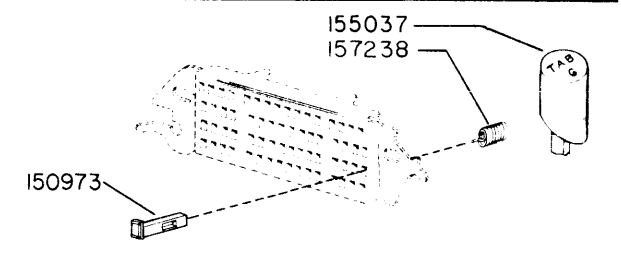
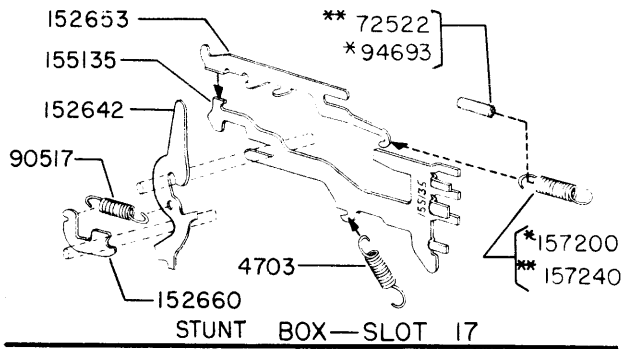


SPECIFICATION 5817S

FIGURE 3-56 152304 MODIFICATION KIT TO PROVIDE HORIZONTAL TABULATION MECHANISM  
(CONTINUED ON NEXT PAGE)



SPECIFICATION 5817S



- \*USED ON UNITS EQUIPPED WITH A TWO-STOP FUNCTION CLUTCH
- \*\*USED ON UNITS EQUIPPED WITH A ONE-STOP FUNCTION CLUTCH

FIGURE 3-57. 152304 MODIFICATION KIT TO PROVIDE HORIZONTAL TABULATION (CONTINUED FROM PRECEDING PAGE)

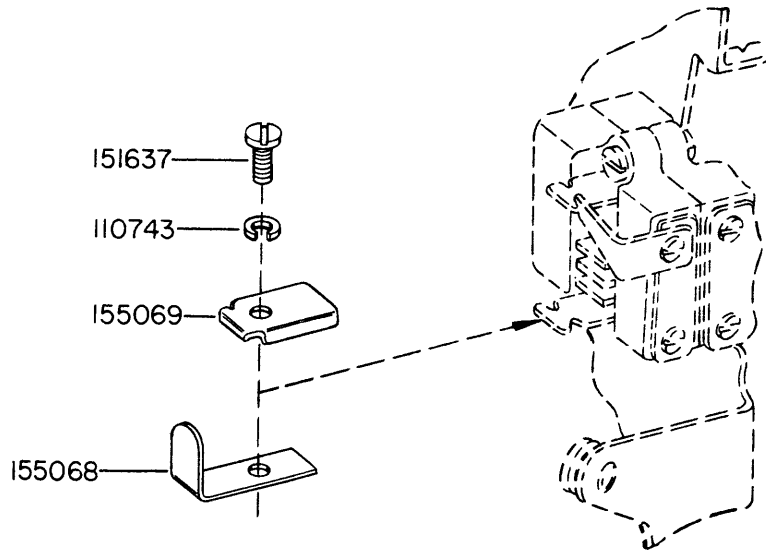
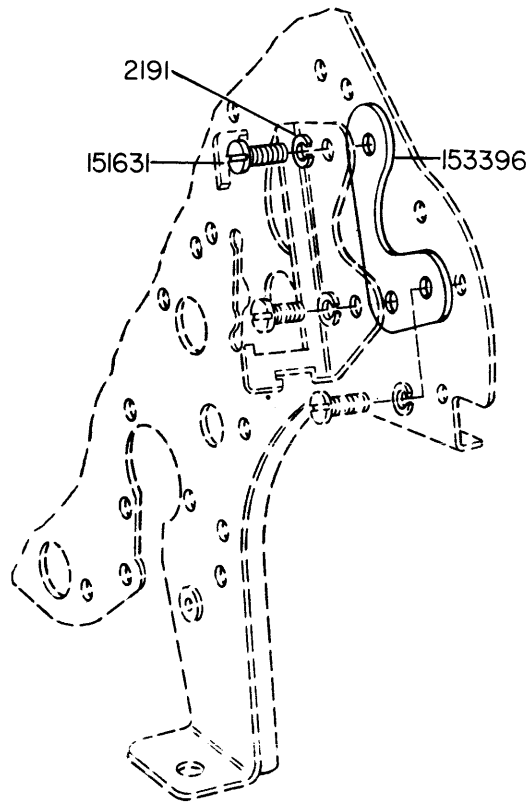
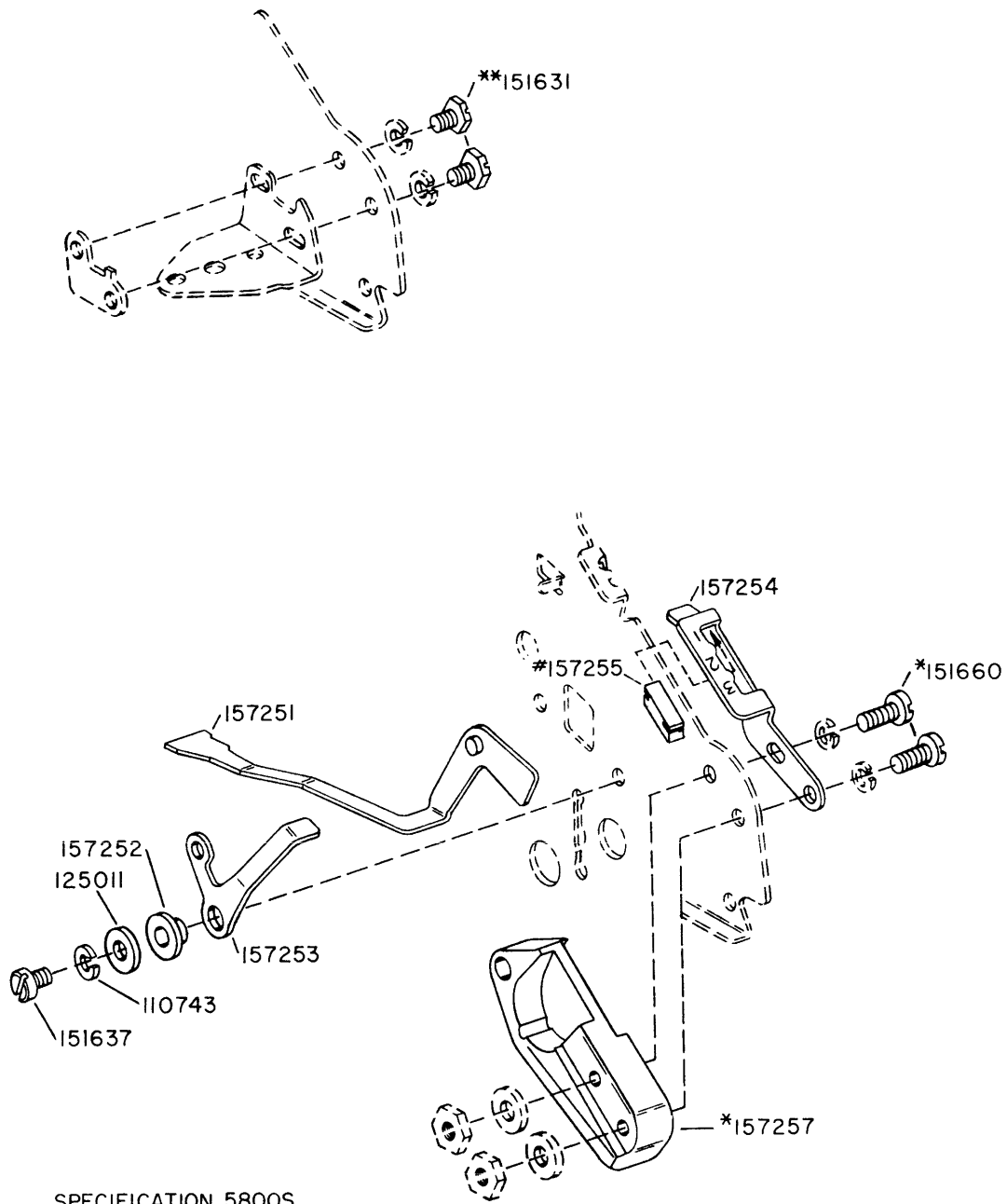


FIGURE 3-58. 153912 MODIFICATION KIT TO PROVIDE FIGS.—LTRS. CODE BAR MANUAL SHIFTING



SPECIFICATION 5793S

FIGURE 3-59. 152312 MODIFICATION KIT TO CONVERT PRINTER FOR USE WITH LIGHTWEIGHT SET

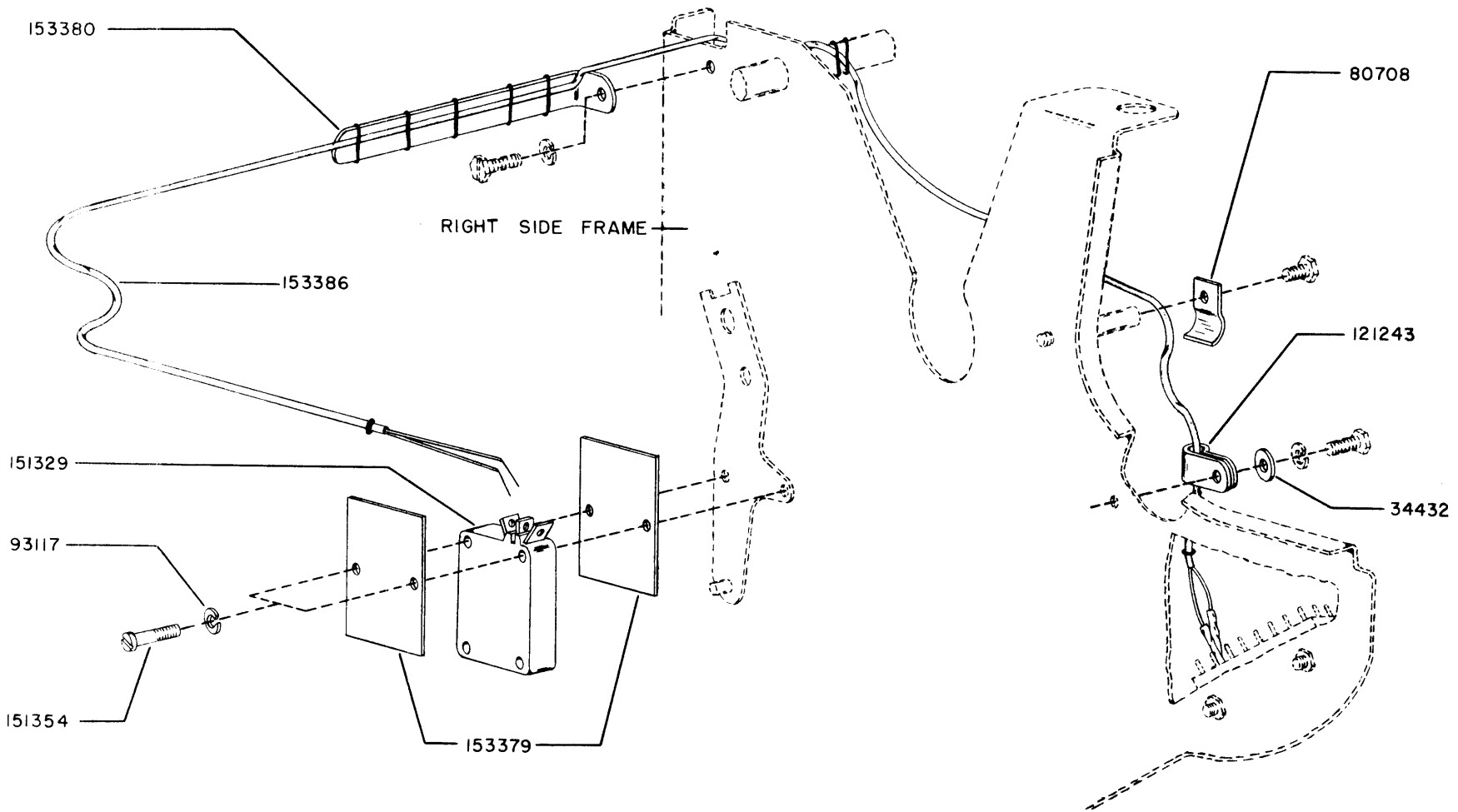


SPECIFICATION 5800S

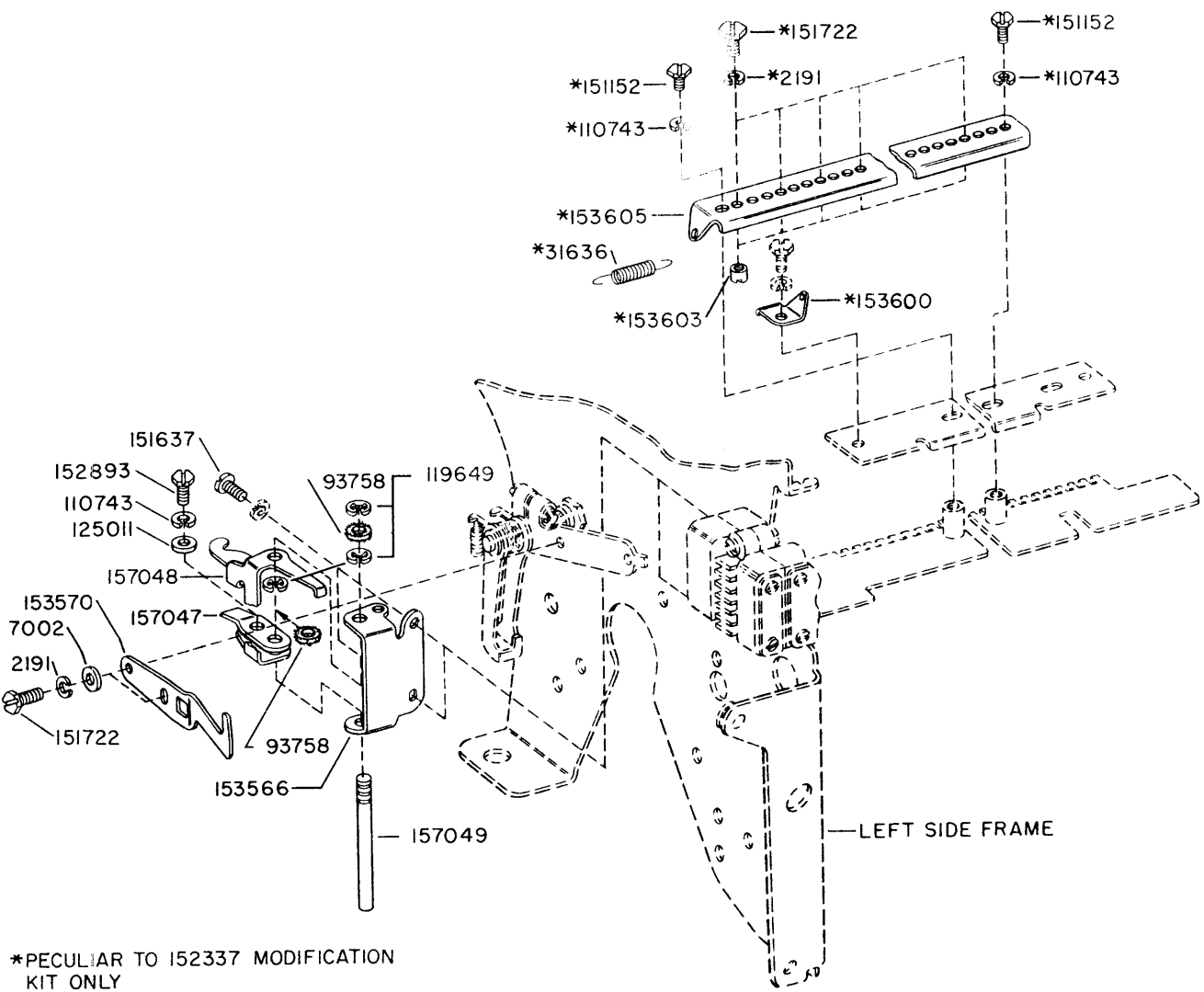
- #PECULIAR TO SPROCKET FEED UNITS HAVING EXTERNAL PULSE SHIFT
- \* PECULIAR TO 154743
- \*\* PECULIAR TO 152315

FIGURE 3-60. 152315 AND 154743 MODIFICATION KITS TO PROVIDE MANUAL SELECTION OF STUNT BOX OPERATION

FIGURE 3-61. 152317 MODIFICATION KIT TO PROVIDE HORIZONTAL TABULATOR XD CONTROL



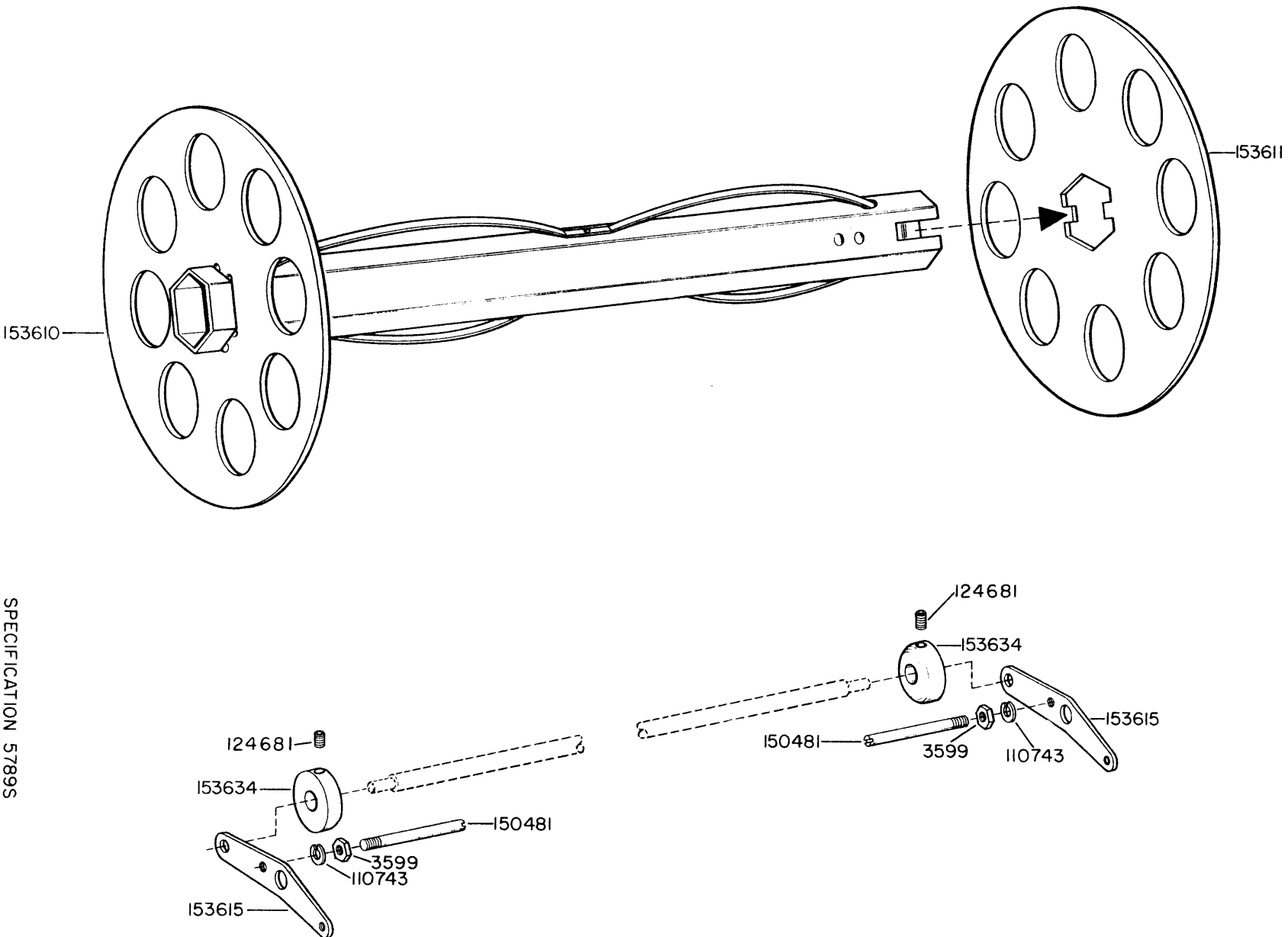
SPECIFICATION 5817S



\*PECULIAR TO 152337 MODIFICATION  
KIT ONLY

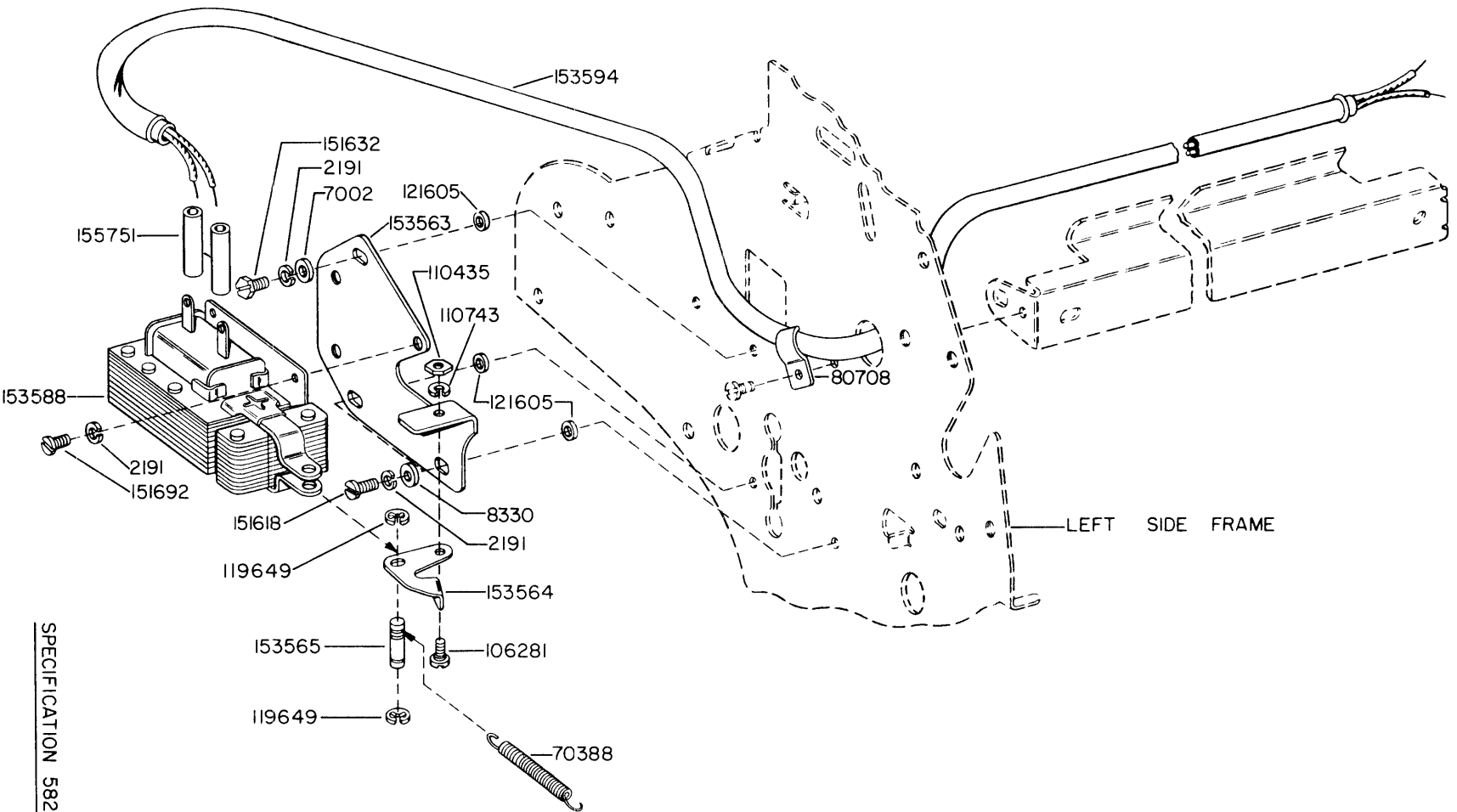
SPECIFICATION 58235

FIGURE 3-62 152337 AND 157509 MODIFICATION KITS TO PROVIDE ON-LINE STUNT  
SHIFT CONTROL



SPECIFICATION 5789S

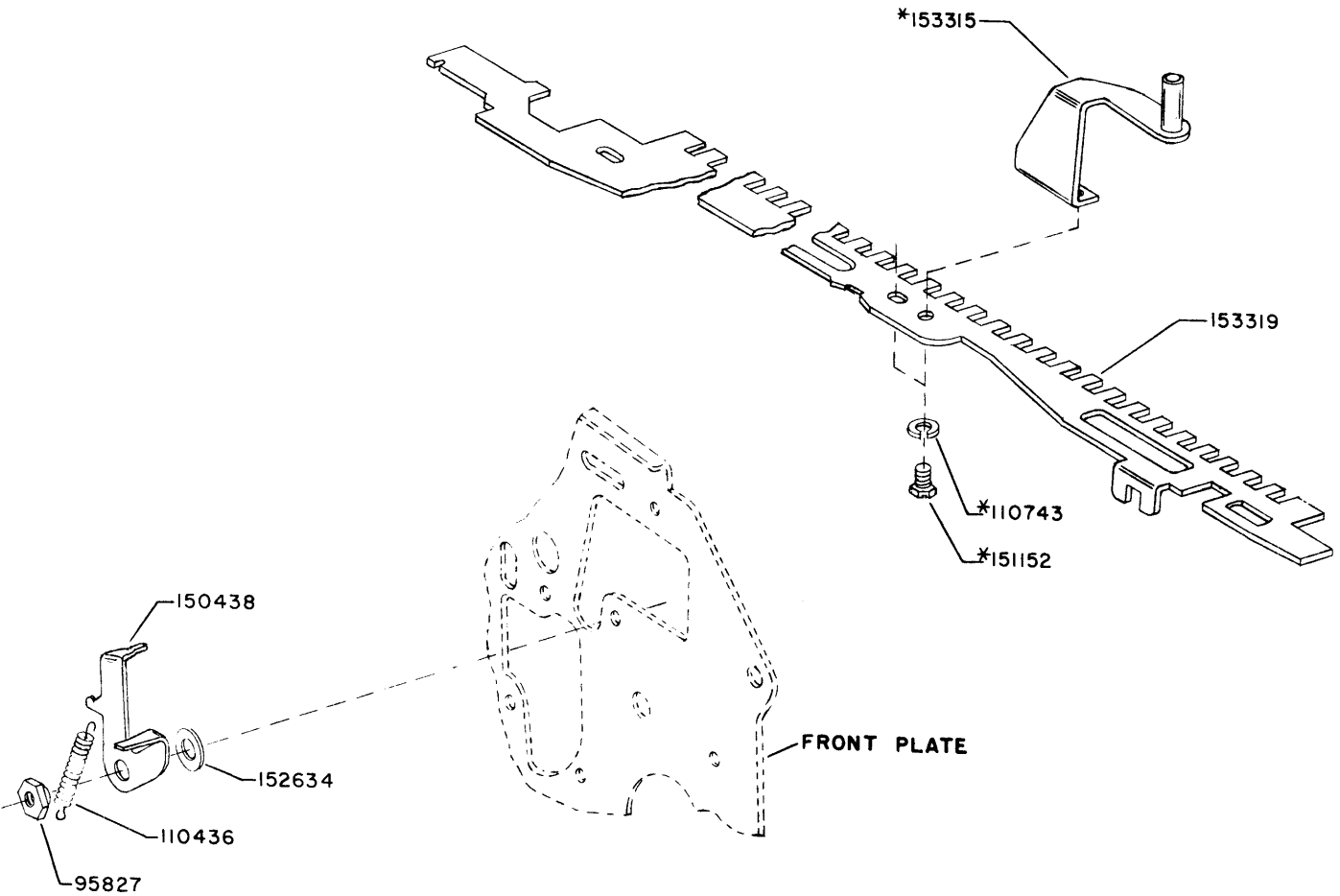
FIGURE 3-63 152340 MODIFICATION KIT TO PROVIDE MULTI-COPY PAPER HANDLING



SPECIFICATION 58235

FIGURE 3-64. 152345 MODIFICATION KIT TO PROVIDE OFF-LINE STUNT SHIFT CONTROL





\*PECULIAR TO 153945  
 \*\*PECULIAR TO 152348

SPECIFICATION 57885

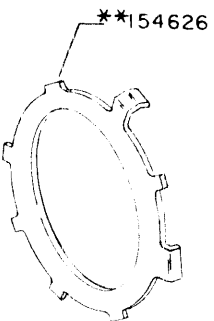


FIGURE 3-65. 152348 AUTOMATIC CARRIAGE RETURN AND LINE FEED AND 153945 "O"  
 CODE BAR AND BELLCRANK MODIFICATION KITS

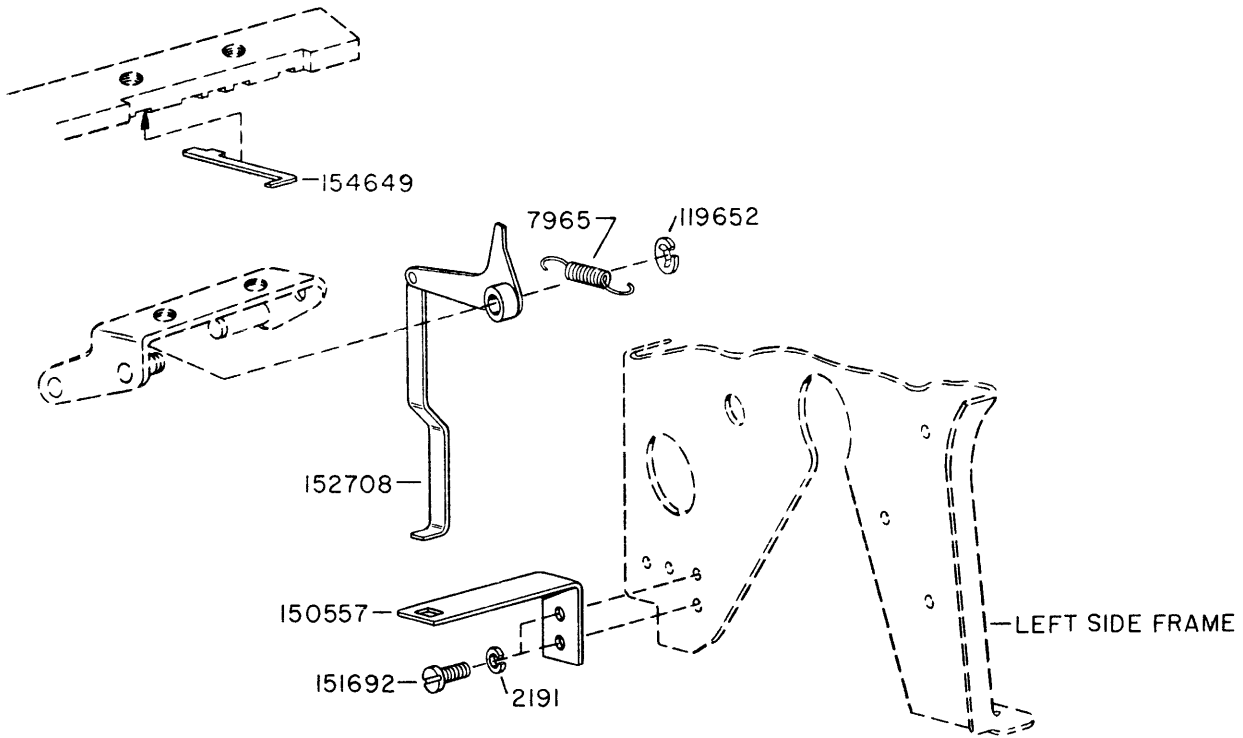
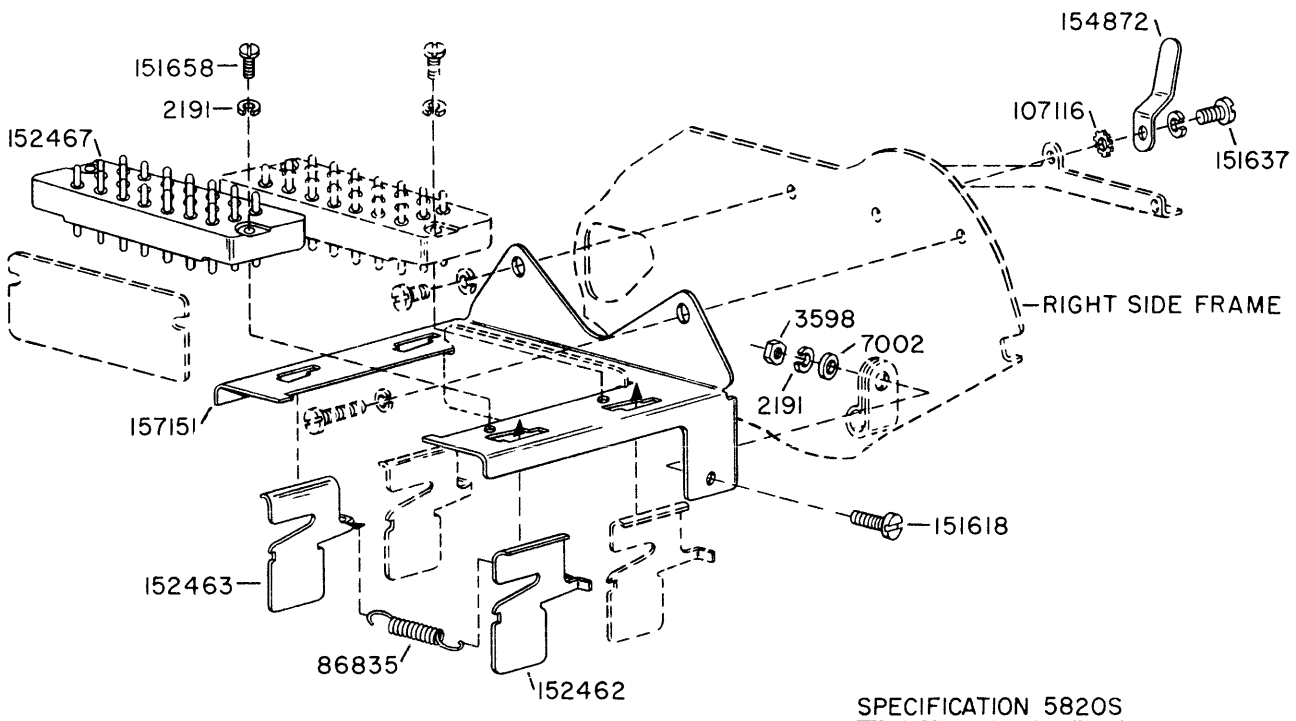
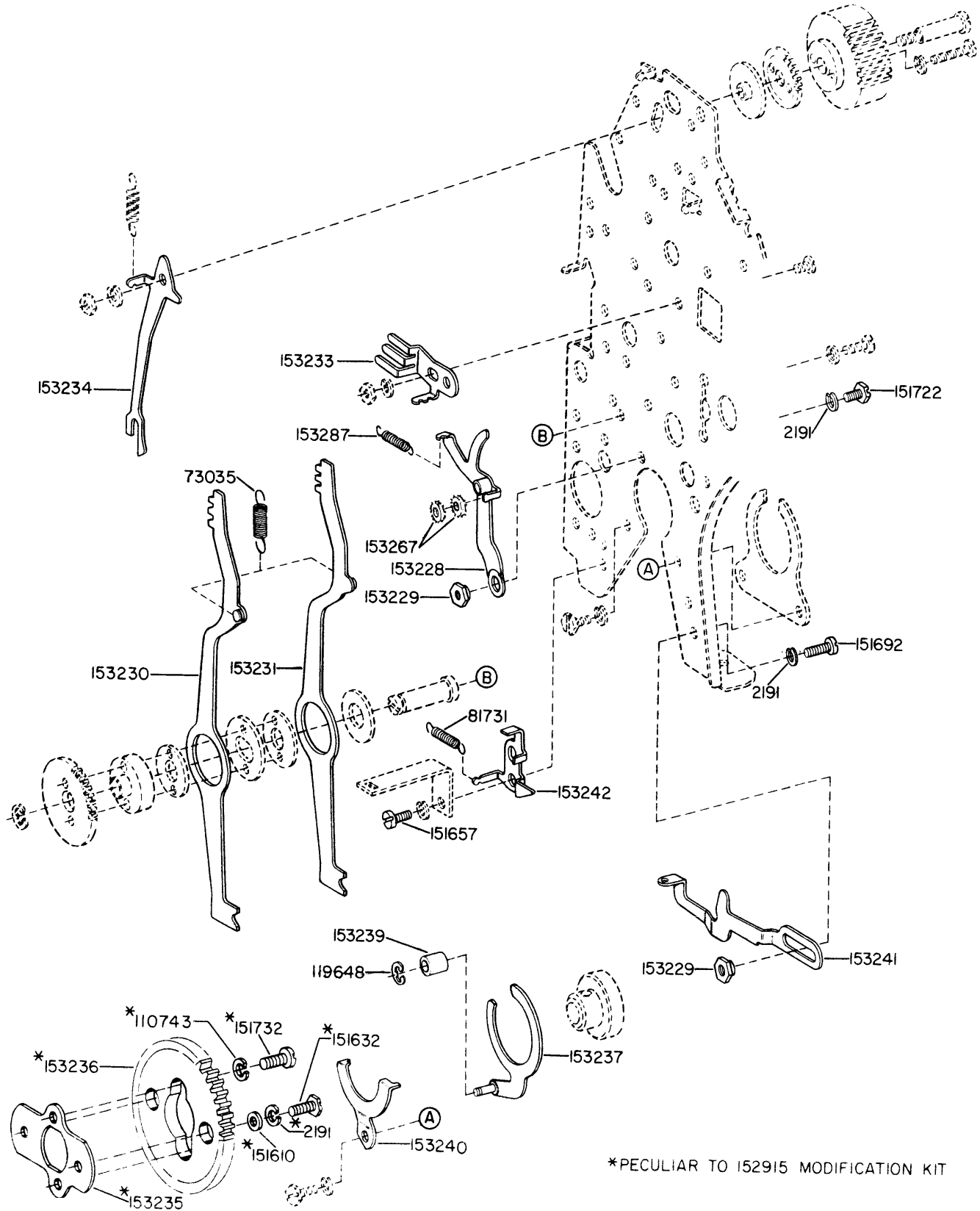


FIGURE 3-66. 152350 MODIFICATION KIT TO PROVIDE KEYBOARD LOCK



SPECIFICATION 5820S

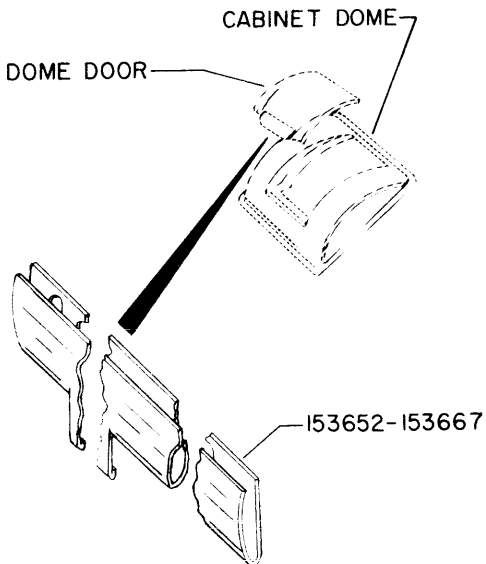
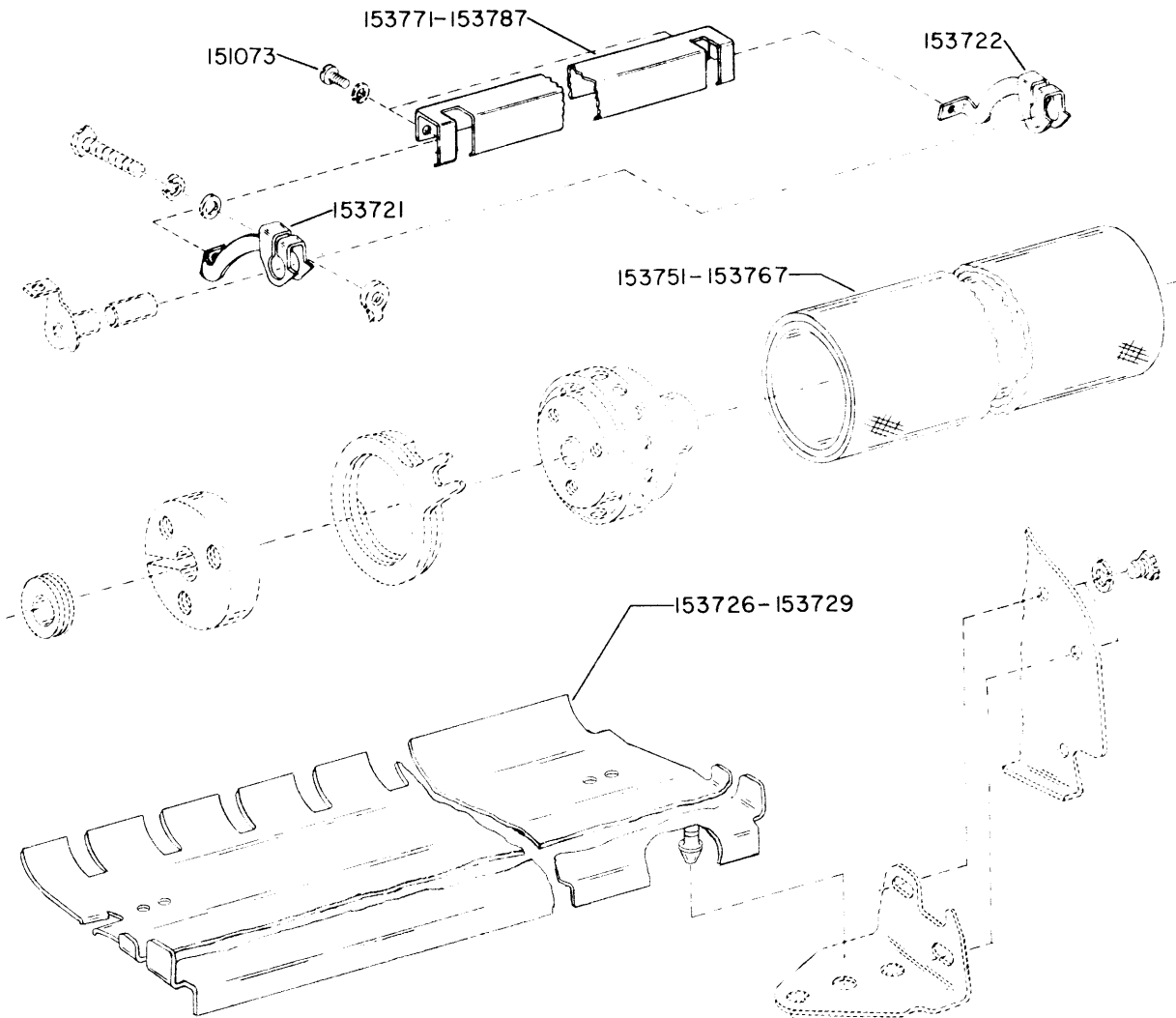
FIGURE 3-67. 153919 MODIFICATION KIT TO PROVIDE AUXILIARY CONNECTOR



SPECIFICATION 5765S

FIGURE 3-68 152915 AND 157511 MODIFICATION KITS TO PROVIDE LOCAL REVERSE LINE FEED

11498

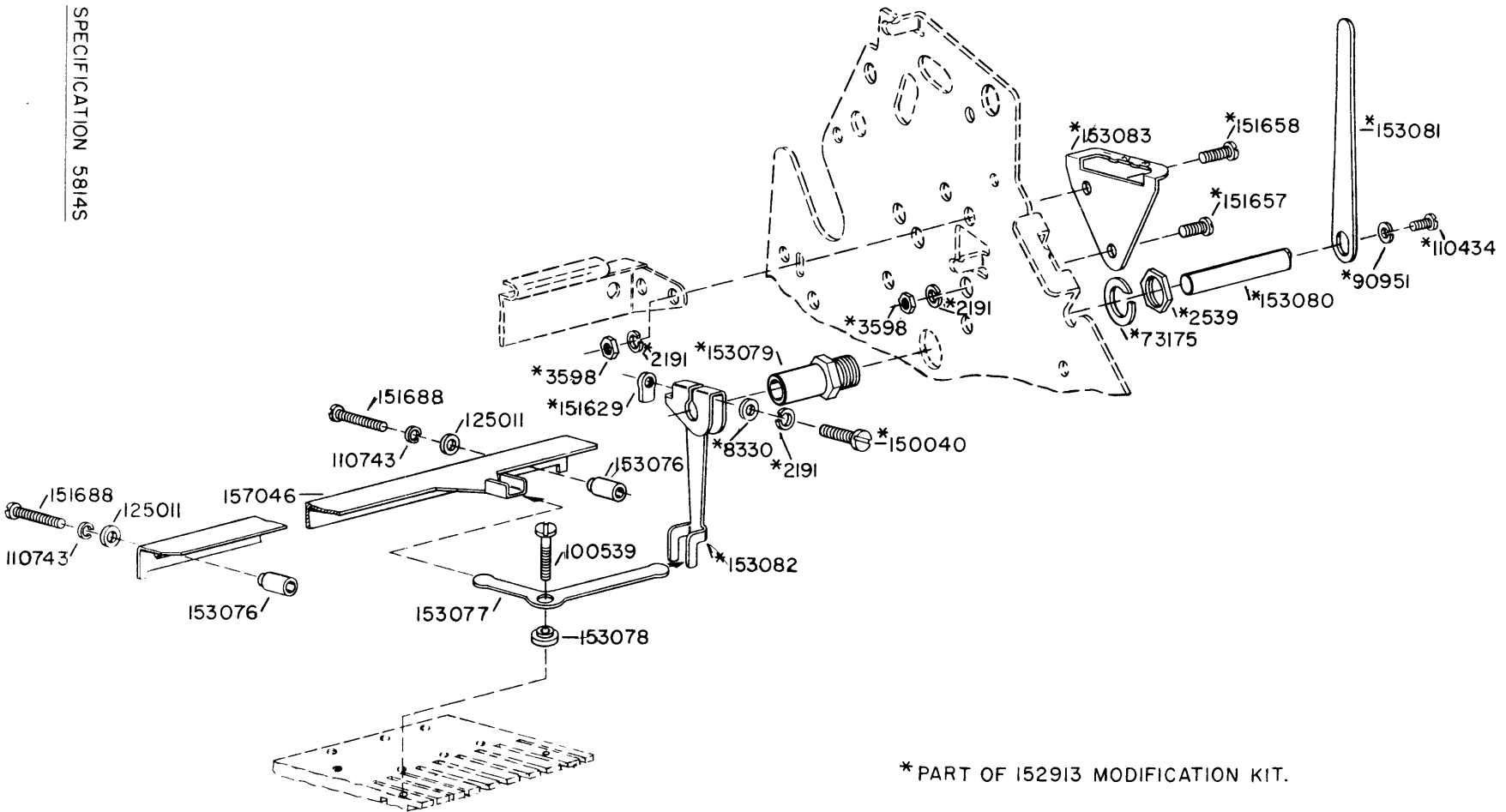


* PAPER WIDTHS	PAPER TRAY	GUIDE BRACKET	MOD. KIT: PAPER HANDLING PARTS		
			KIT. NO.	PLATEN	FORM GUIDE
9"	153727	153771	153701	153751	153652
8-1/2"	153726	153772	153702	153752	153653
8"	153727	153773	153703	153753	153654
7-1/2"	153726	153774	153704	153754	153655
7"	153727	153775	153705	153755	153656
6-1/2"	153726	153776	153706	153756	153657
6-3/8"	153728	153777	153707	153757	153658
6-1/4"	153729	153778	153708	153758	153659
6"	153727	153779	153709	153759	153660
5-3/4"	153728	153780	153710	153760	153661
5-1/2"	153726	153781	153711	153761	153662
5"	153727	153782	153712	153762	153663
4-1/2"	153726	153783	153713	153763	153664
4-5/16"	153729	153784	153714	153764	153665
4-1/4"	153728	153785	153715	153765	153665
4"	153727	153786	153716	153766	153666
3-5/8"	153726	153787	153717	153767	153667

\* THE WIDTH SHOWN IS THE OVERALL DIMENSION OF THE PAPER AND THE DISTANCE BETWEEN SPROCKET PIN HOLES IS 1/2" LESS.  
SPECIFICATION 5792S

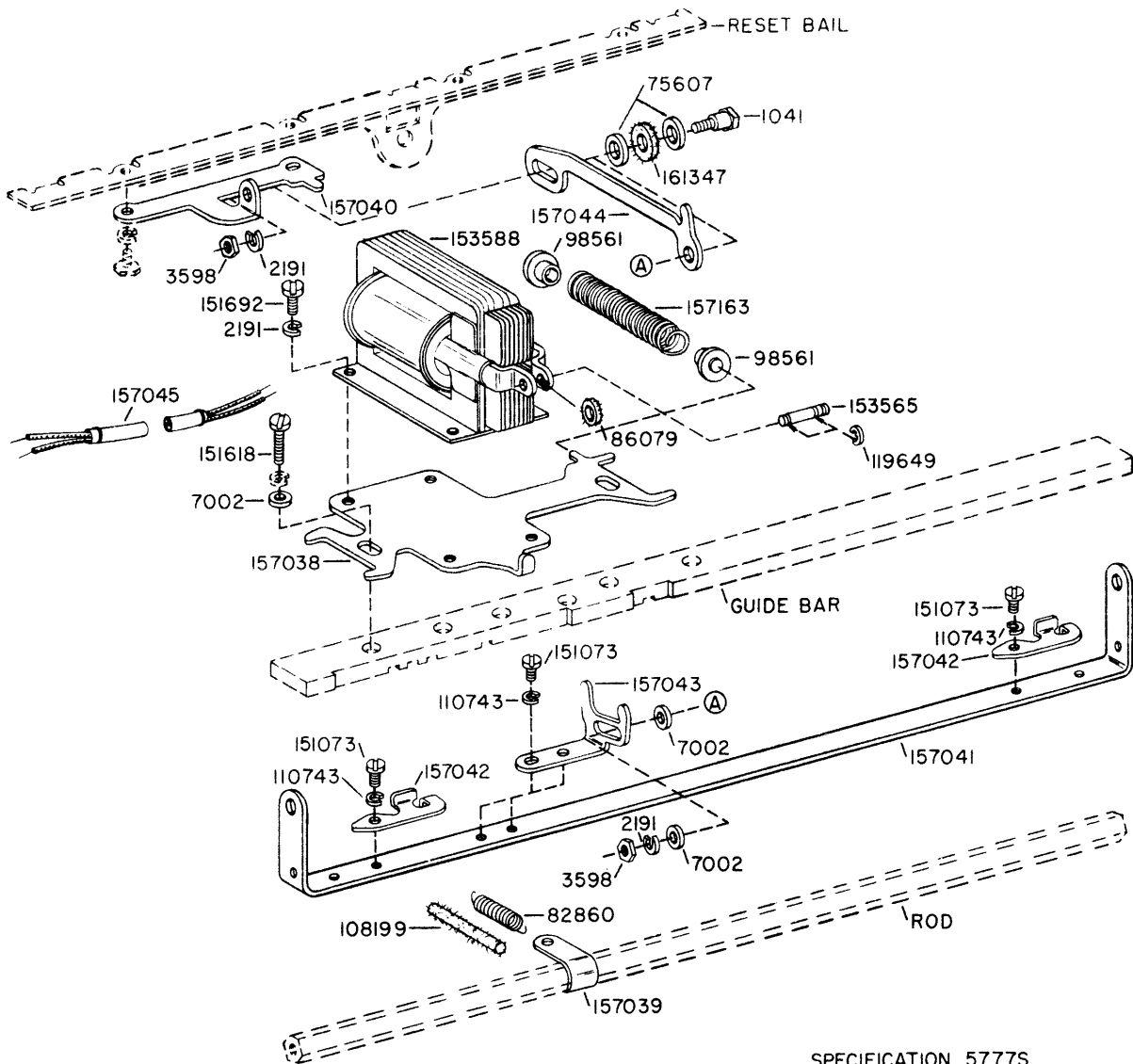
SEE FIGURE I-10 FOR PHANTOMED PARTS

FIGURE 3-69. SPROCKET FEED PAPER HANDLING MODIFICATION KITS (TYPING UNIT AND CABINET)



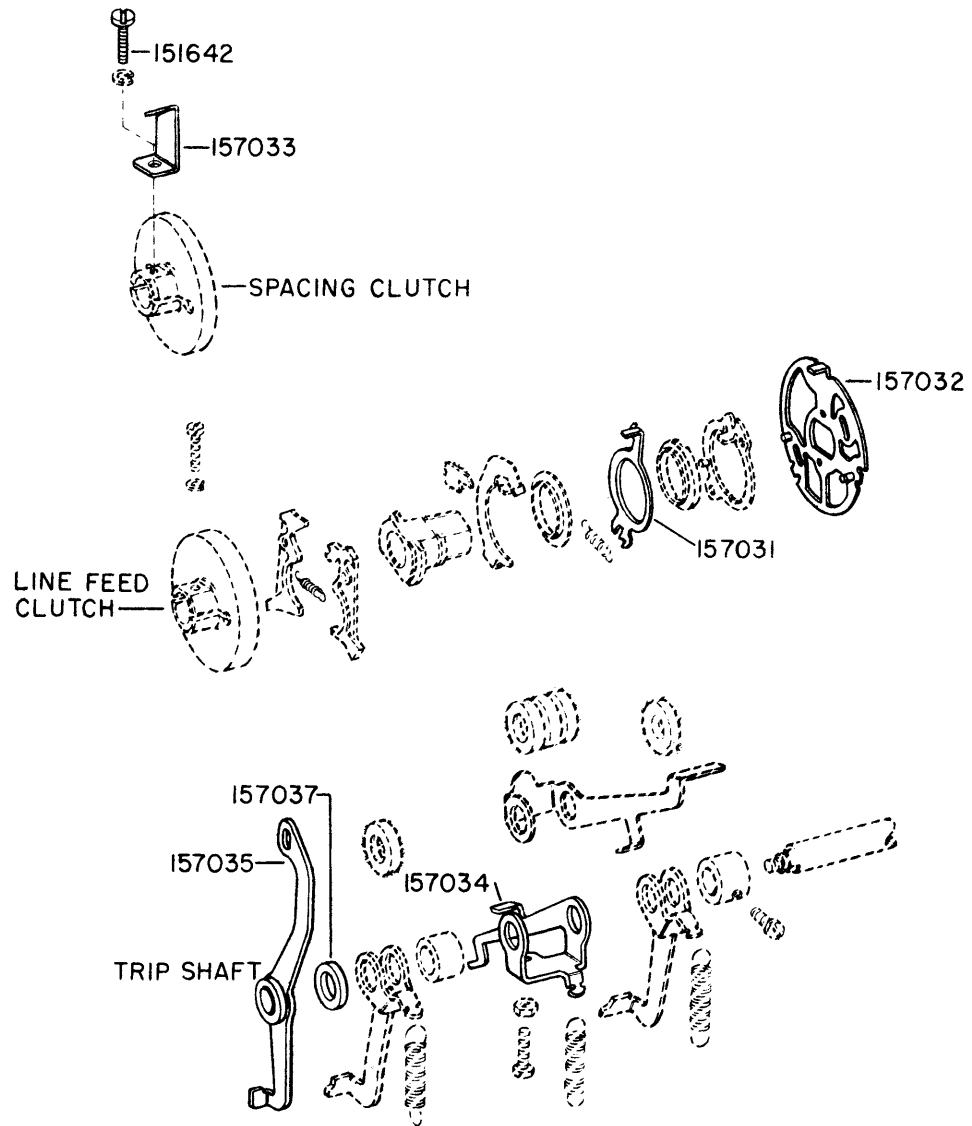
SPECIFICATION 5814S

FIGURE 3-70 153910 MODIFICATION KIT TO PROVIDE FUNCTION SUPPRESSION FOR "AZ" STUNT BOX



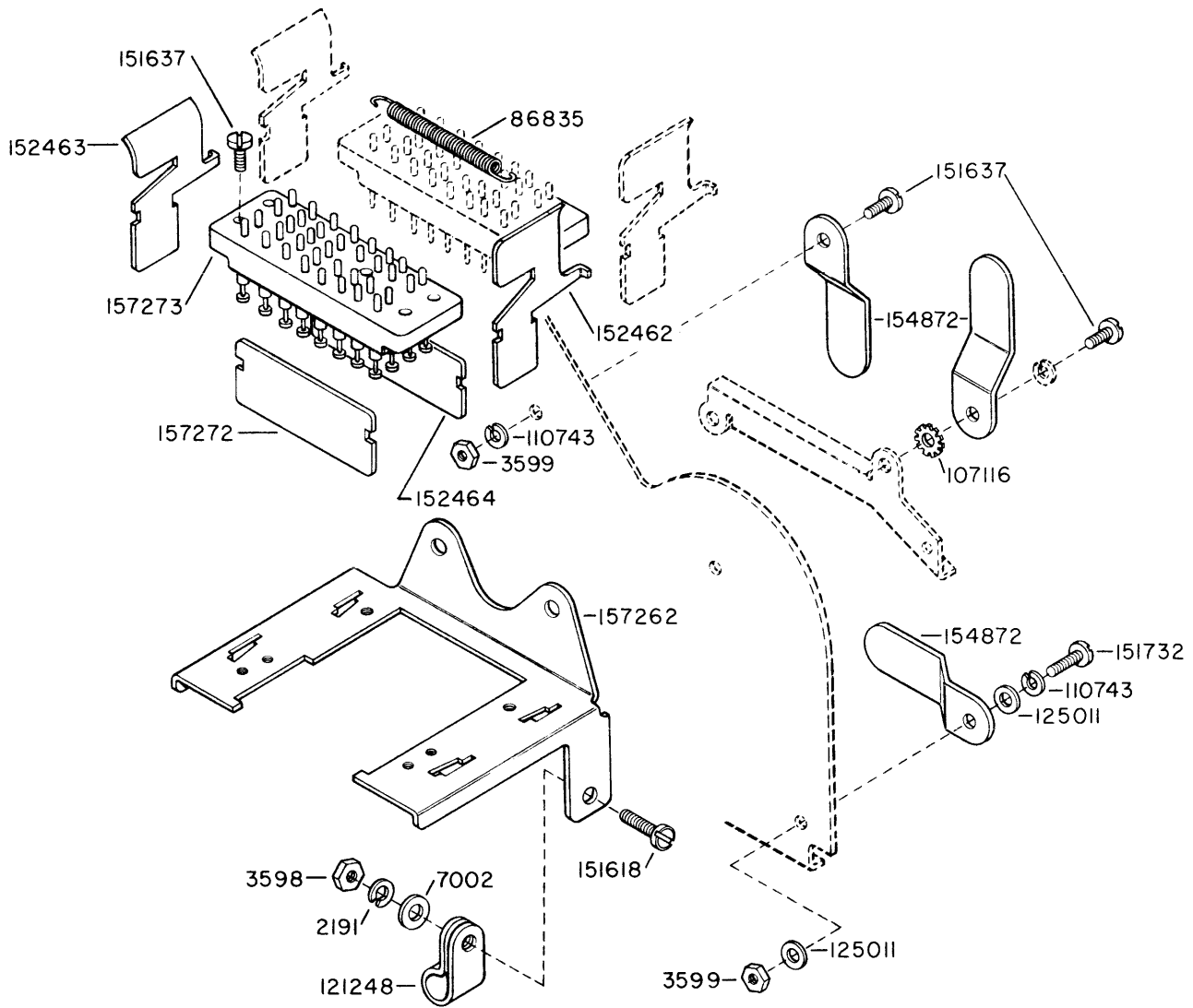
SPECIFICATION 5777S

FIGURE 3-71. 1539II MODIFICATION KIT TO PROVIDE CONTINUOUS SPACING  
(CONTINUED ON NEXT PAGE)



SPECIFICATION 5777S

FIGURE 3-72. 1539II MODIFICATION KIT TO PROVIDE CONTINUOUS SPACING  
(CONTINUED FROM PRECEDING PAGE)

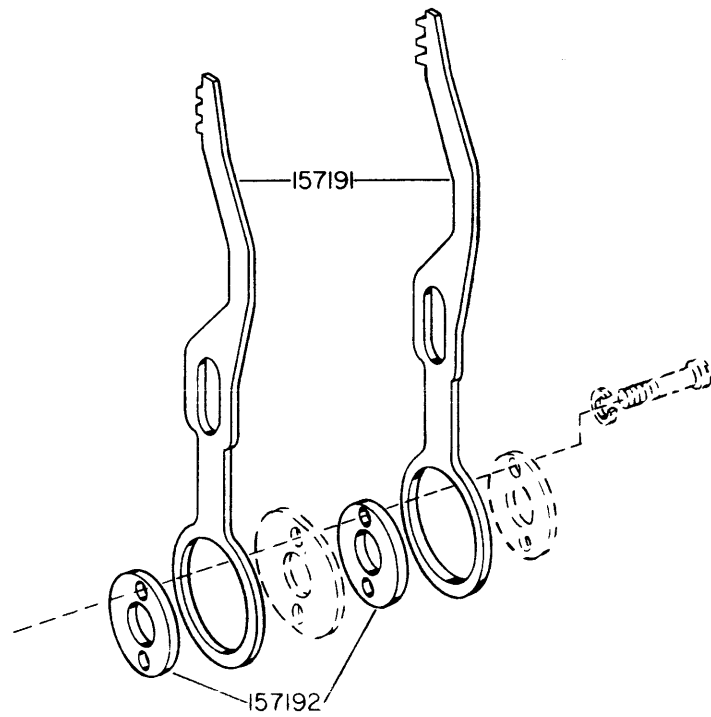
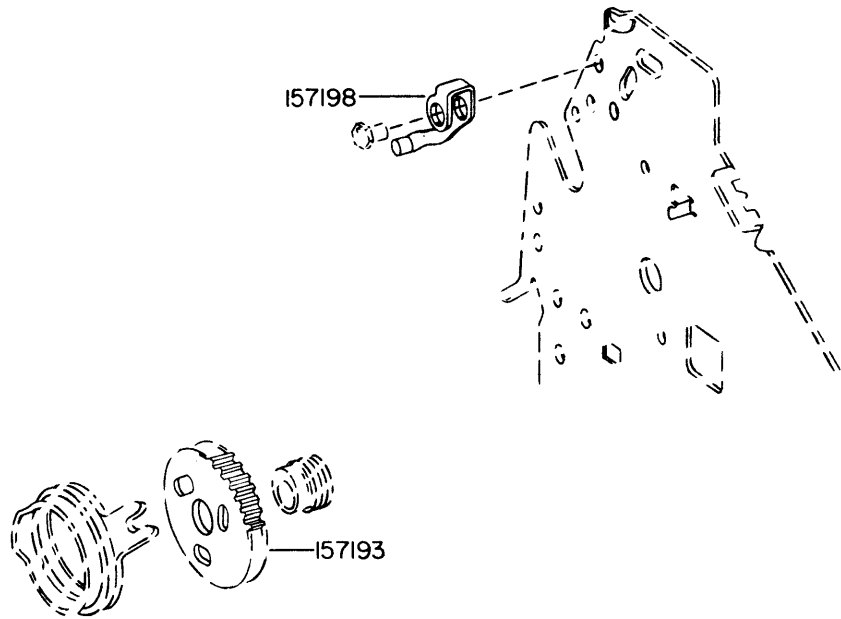


SPECIFICATION 5839S

FIGURE 3-73. I54727 MODIFICATION KIT TO PROVIDE AUXILIARY CONNECTOR



1149B



SPECIFICATION 5854S

FIGURE 3-74. 154742 MODIFICATION KIT TO PROVIDE FOUR LINES PER INCH

11498

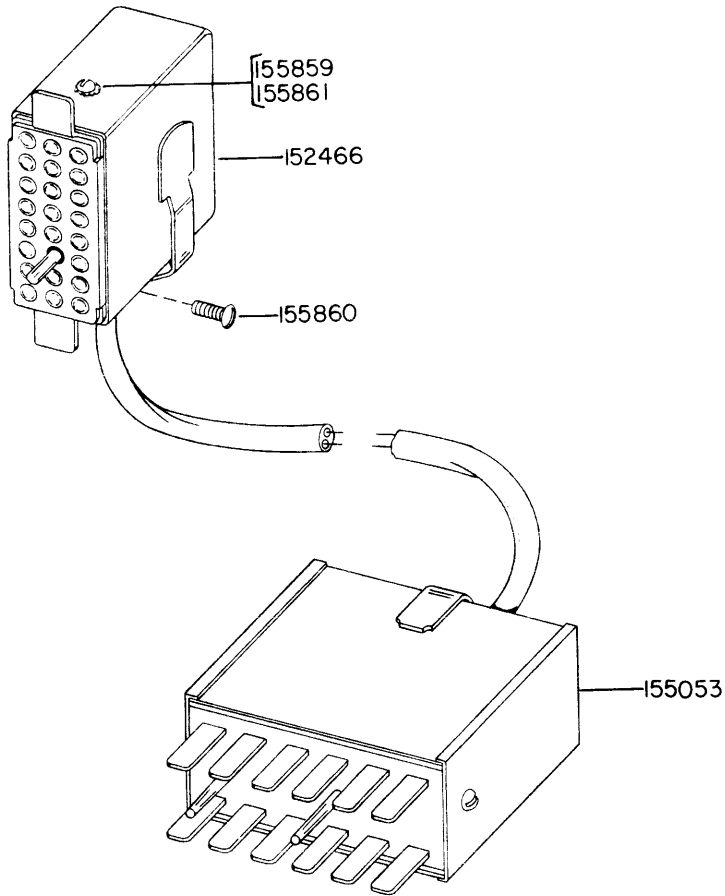
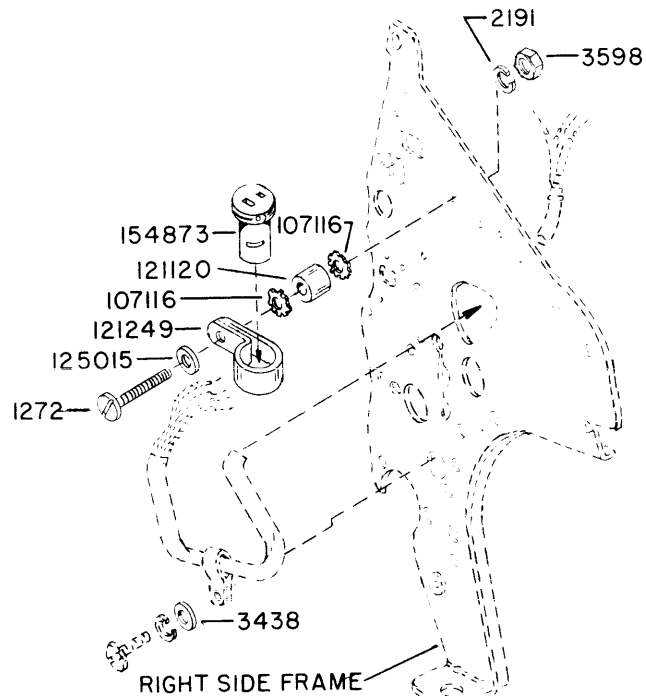


FIGURE 3-75. I55051 AUXILIARY CABLE ASSEMBLY



SPECIFICATION 5821S

FIGURE 3-76. I54753 MODIFICATION KIT TO PROVIDE AUXILIARY CONNECTOR

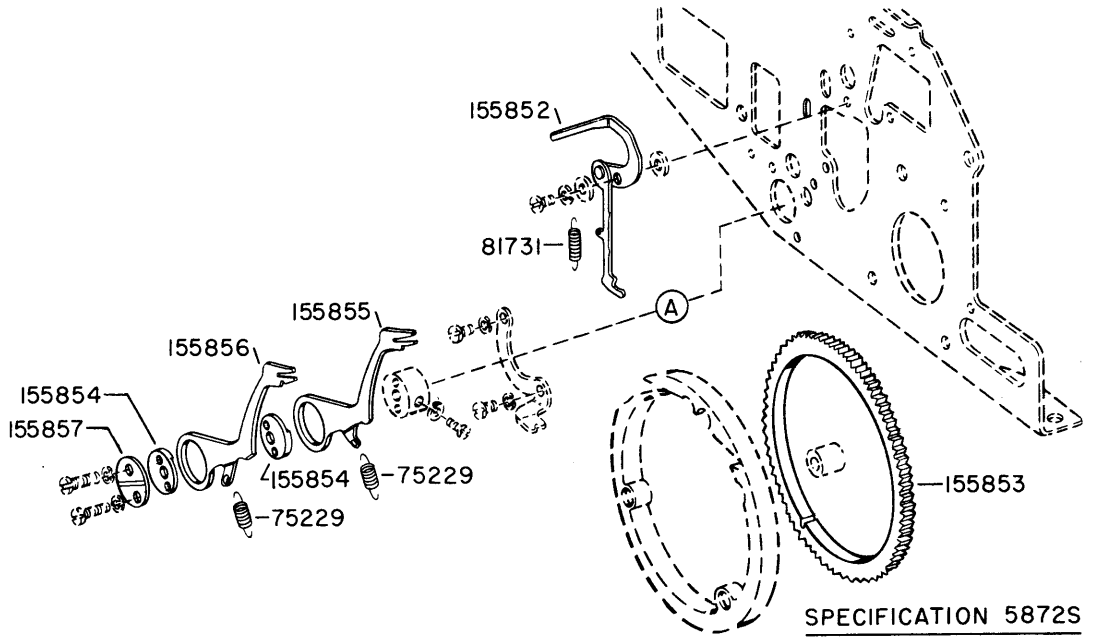


FIGURE 3-77. 154755 MODIFICATION KIT TO PROVIDE 5 SPACES PER INCH HORIZONTALLY

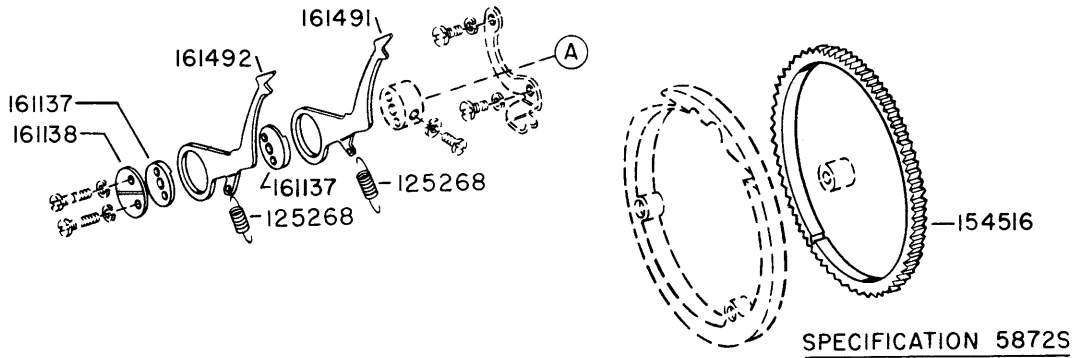


FIGURE 3-78. 159395 MODIFICATION KIT TO PROVIDE 6 SPACES PER INCH HORIZONTALLY

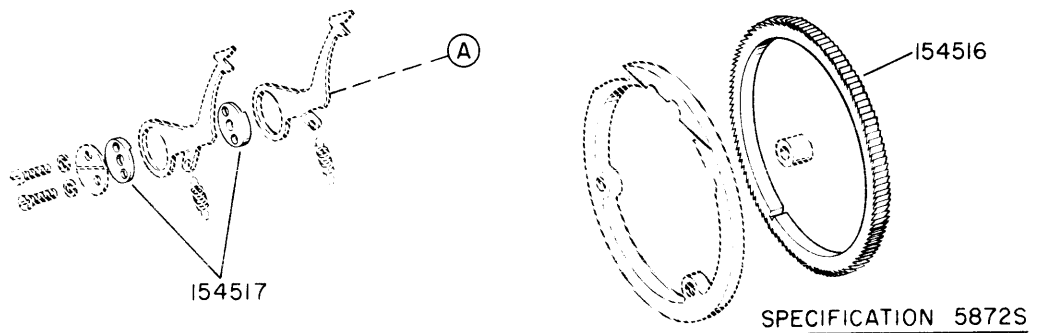
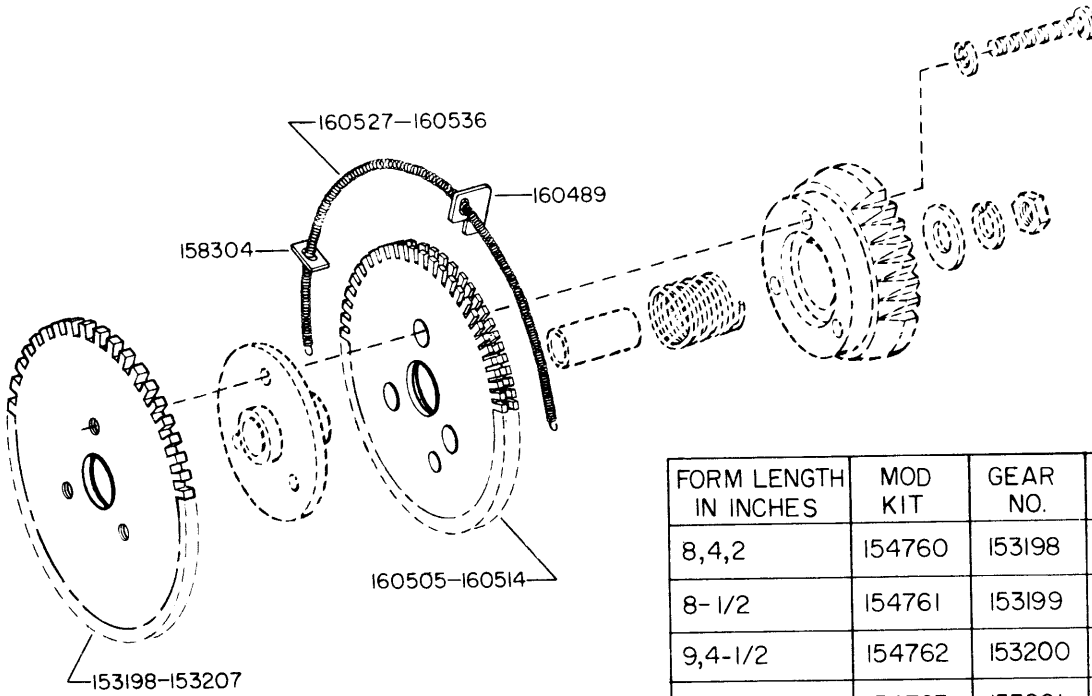


FIGURE 3-79. 154792 MODIFICATION KIT TO PROVIDE 12 SPACES PER INCH HORIZONTALLY



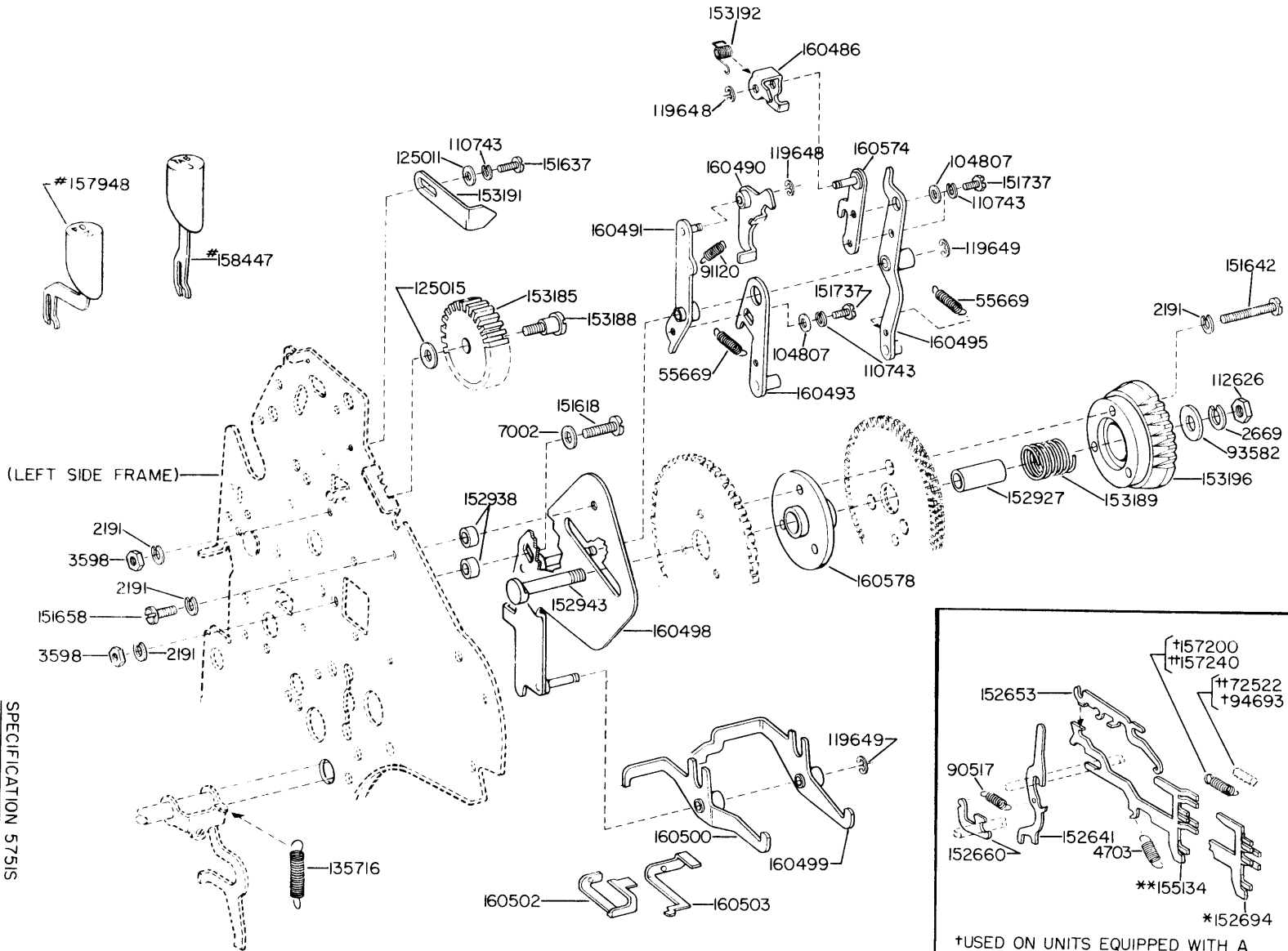
FOR PHANTOMED PARTS,  
SEE FIGURE 3-31.

FORM LENGTH IN INCHES	MOD KIT	GEAR NO.	DISK NO.	SPRING NO.
8,4,2	154760	153198	160505	160527
8-1/2	154761	153199	160506	160528
9,4-1/2	154762	153200	160507	160529
9-1/2	154763	153201	160508	160530
10,5	154764	153202	160509	160531
11,5-1/2	154765	153203	160510	160532
12,6,3	154766	153204	160511	160533
13,6-1/2	154767	153205	160512	160534
14,7,3-1/2	154768	153206	160513	160535
7-1/2,15	154769	153207	160514	160536

SPECIFICATION 575IS

FIGURE 3-80. 154760 THROUGH 154769 MODIFICATION  
KITS TO PROVIDE VERTICAL TABULATION

FIGURE 3-81 154770 MODIFICATION KIT TO PROVIDE VERTICAL TABULATION ON UPPER CASE "J" AND "Z"



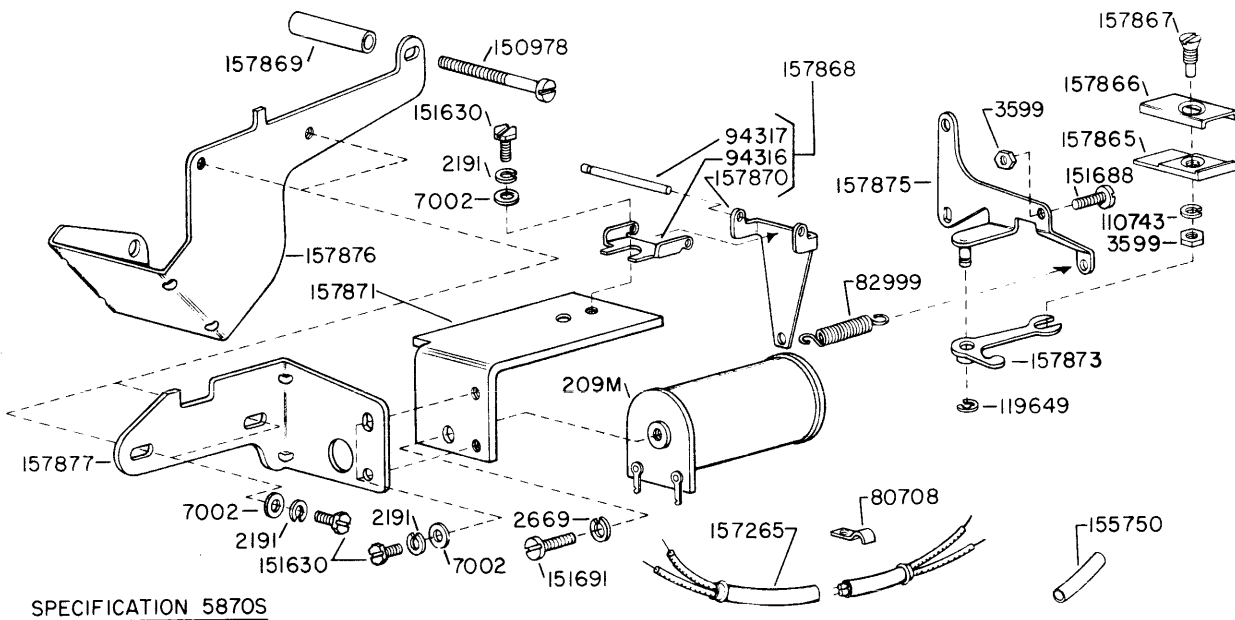
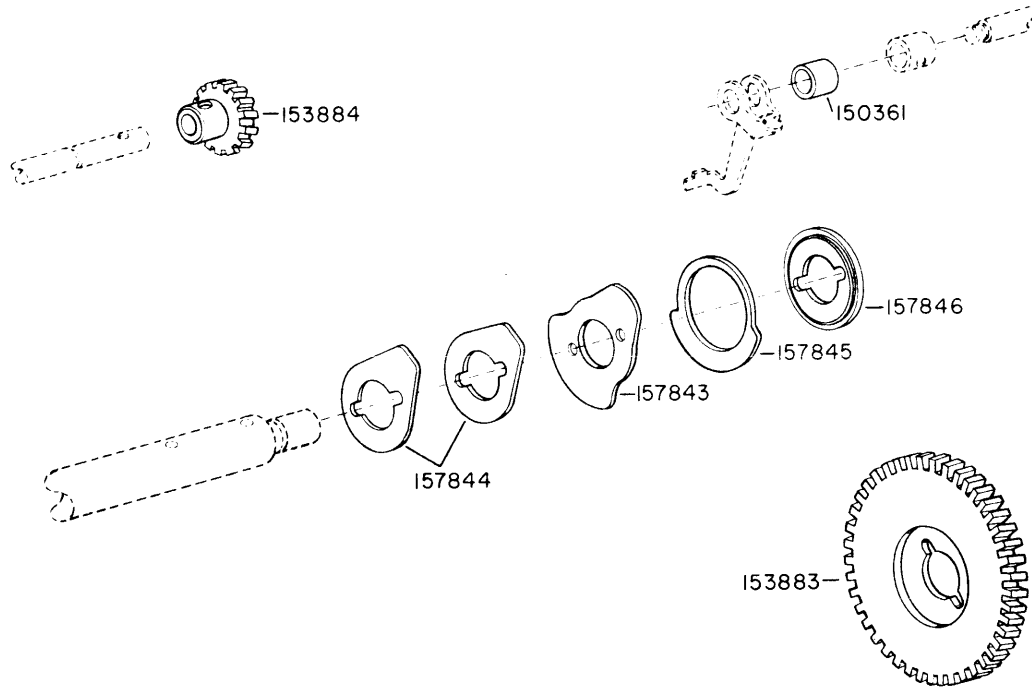
SPECIFICATION 57515

THE 154771 MODIFICATION KIT TO PROVIDE VERTICAL TABULATION CONSISTS OF ALL PARTS ON THIS PAGE EXCEPT THOSE MARKED #.

†157200	††157240
††72522	†94693
152653	
90517	
152660	
152641	
4703	
**155134	
*152694	

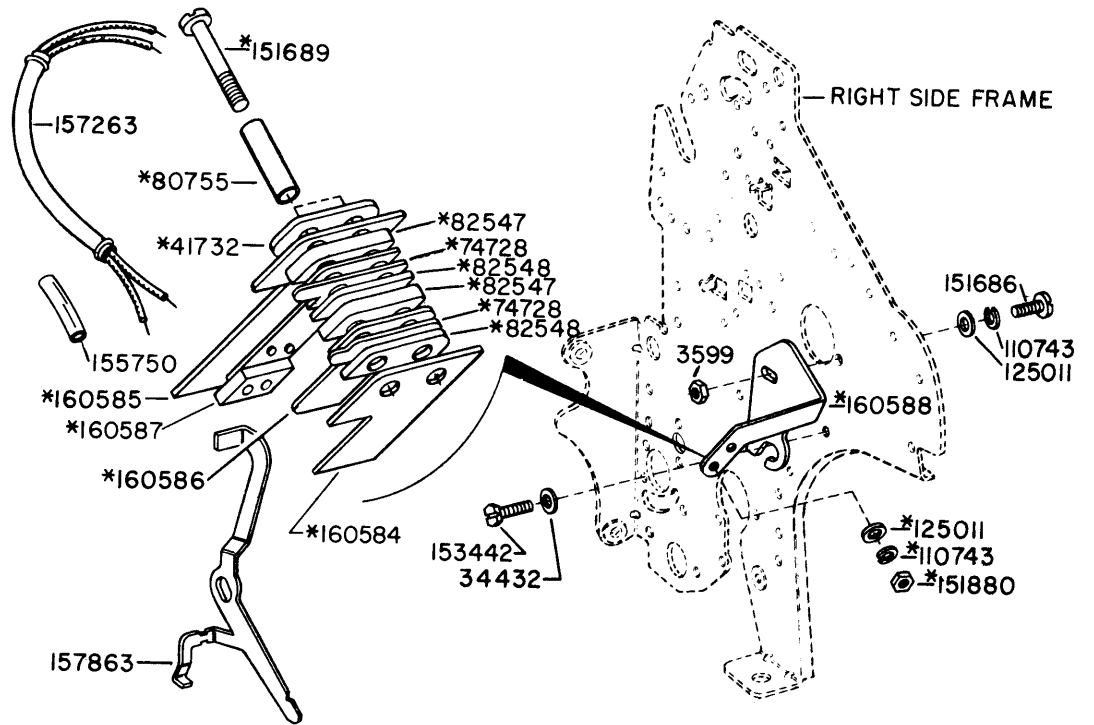
†USED ON UNITS EQUIPPED WITH A TWO-STOP FUNCTION CLUTCH  
 ††USED ON UNITS EQUIPPED WITH A ONE-STOP FUNCTION CLUTCH

#157530 (SLOT 42) \*PECULIAR TO 157531  
 #157531 (SLOT 41) \*\*PECULIAR TO 157530

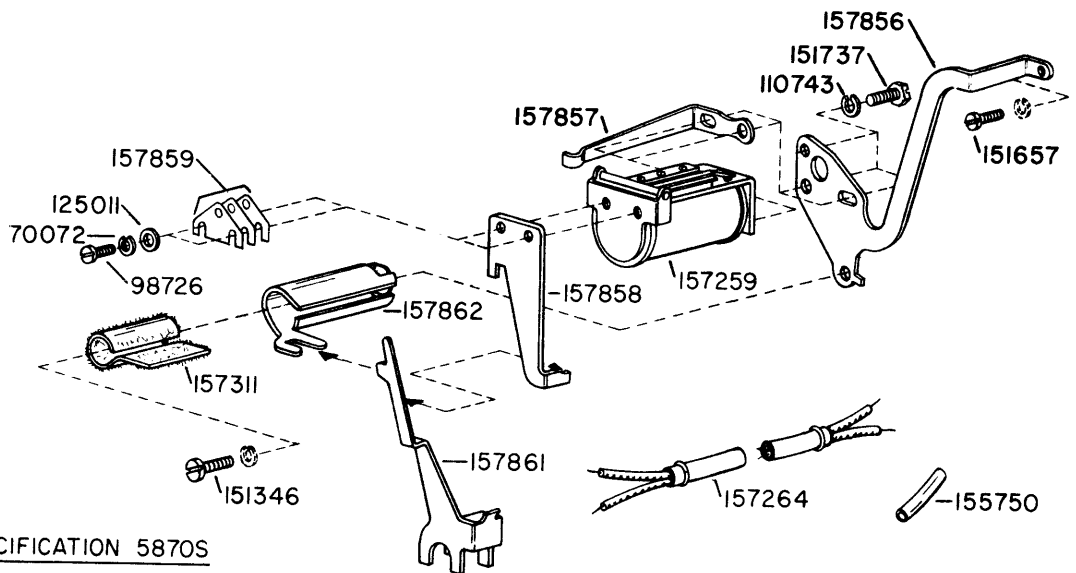


SPECIFICATION 5870S

FIGURE 3-82. 154778 MODIFICATION KIT TO PROVIDE EXTERNAL PULSE SHIFT FEATURE (CONTINUED ON NEXT PAGE)

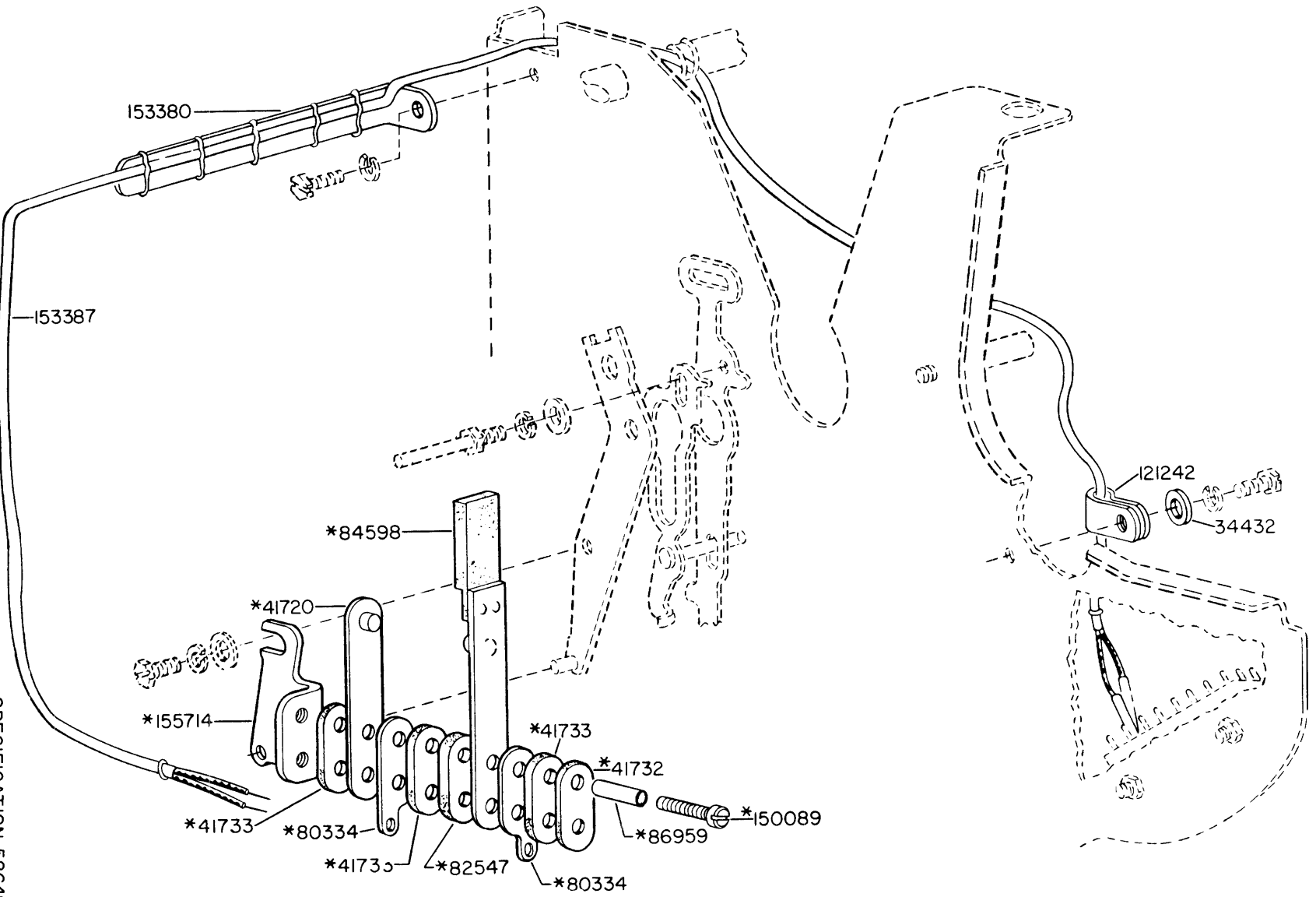


\* PART OF 160589 CONTACT ASSEMBLY



SPECIFICATION 5870S

FIGURE 3-83. 154778 MODIFICATION KIT TO PROVIDE EXTERNAL PULSE SHIFT FEATURE (CONTINUED FROM PRECEDING PAGE)

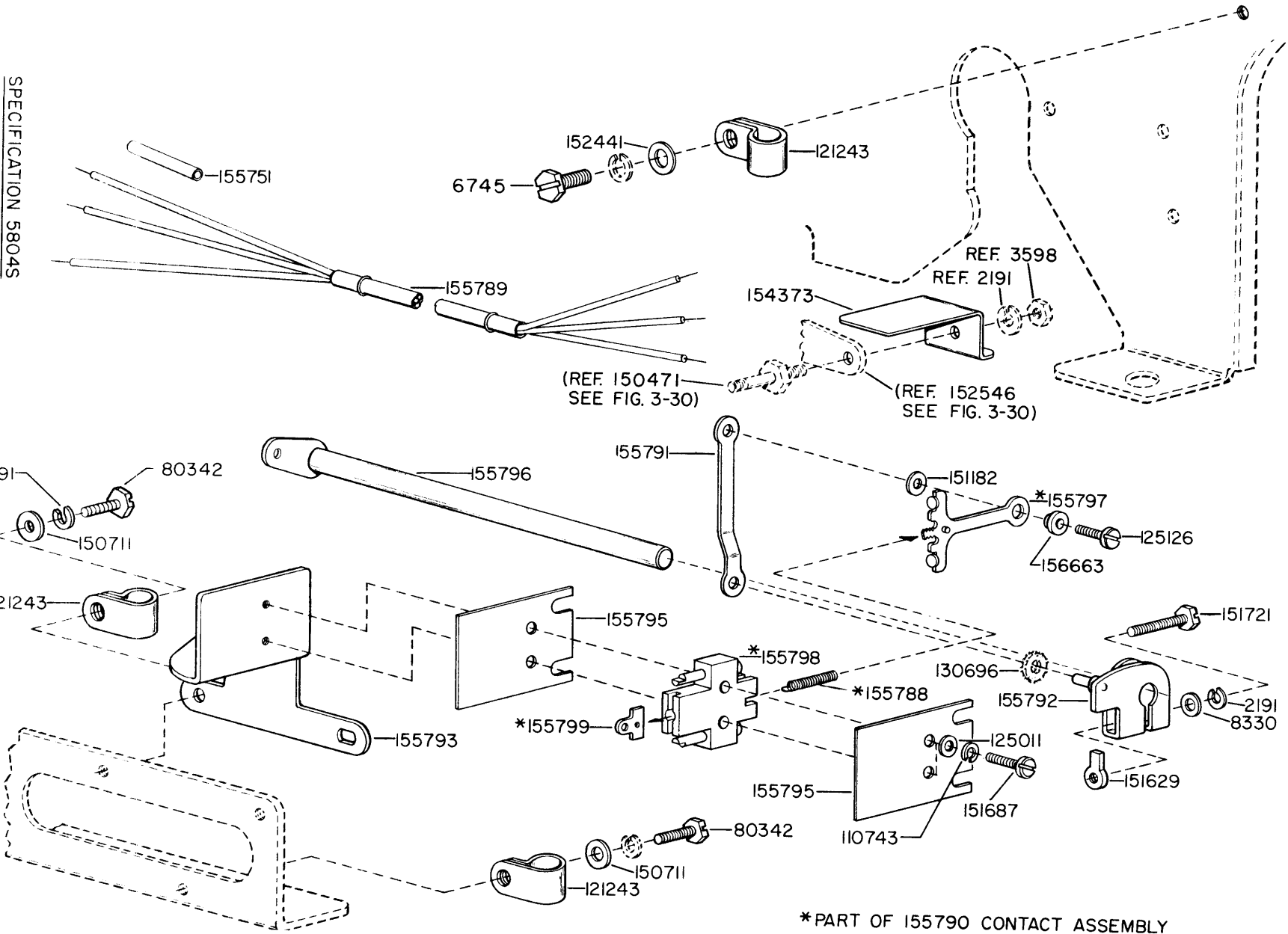


SPECIFICATION 5864S

\*PART OF 155721 CONTACT ASSEMBLY

FIGURE 3-84. 154780 MODIFICATION KIT TO PROVIDE HORIZONTAL TABULATOR XD CONTROL



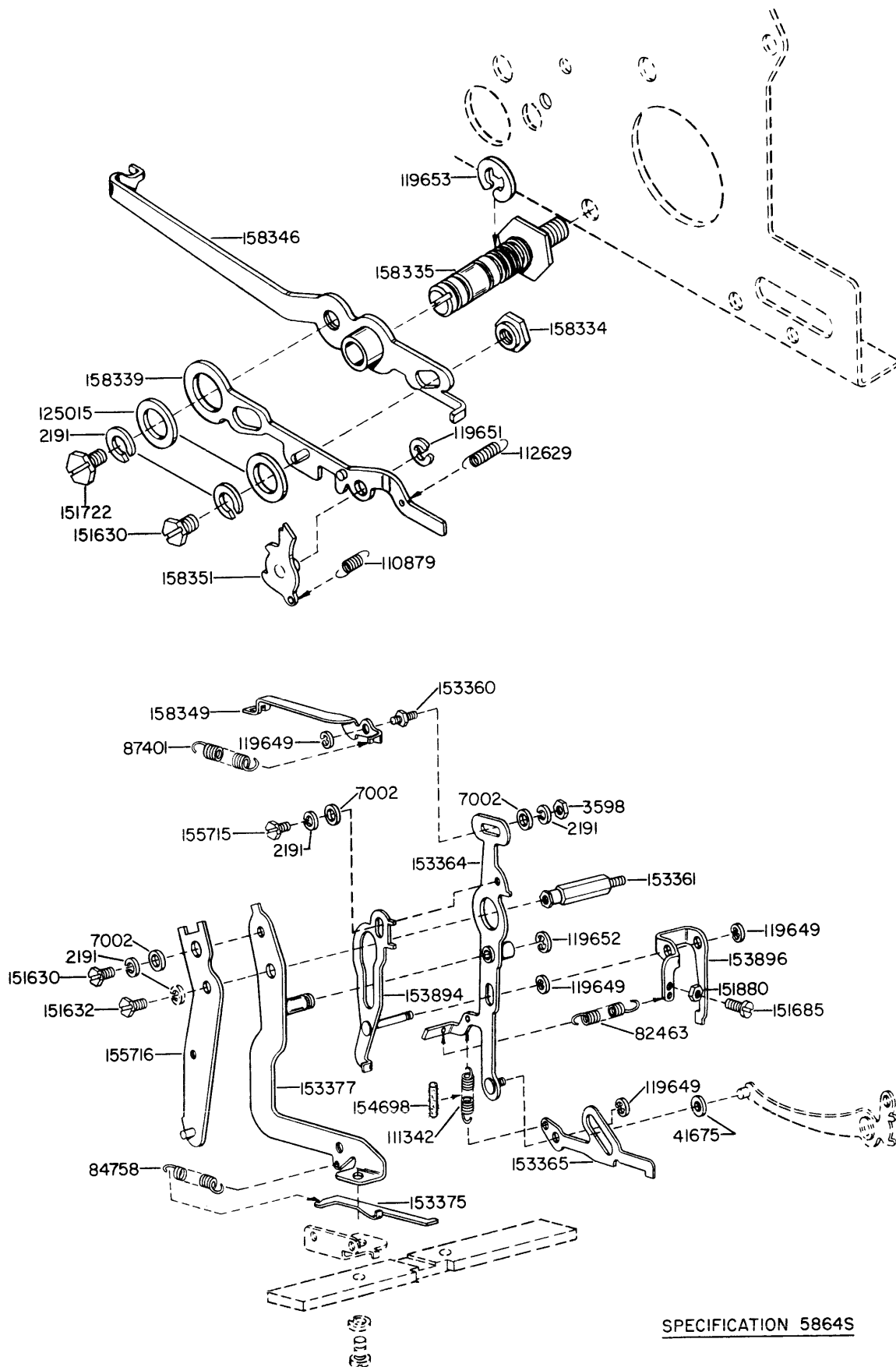


SPECIFICATION 58045

\*PART OF 155790 CONTACT ASSEMBLY

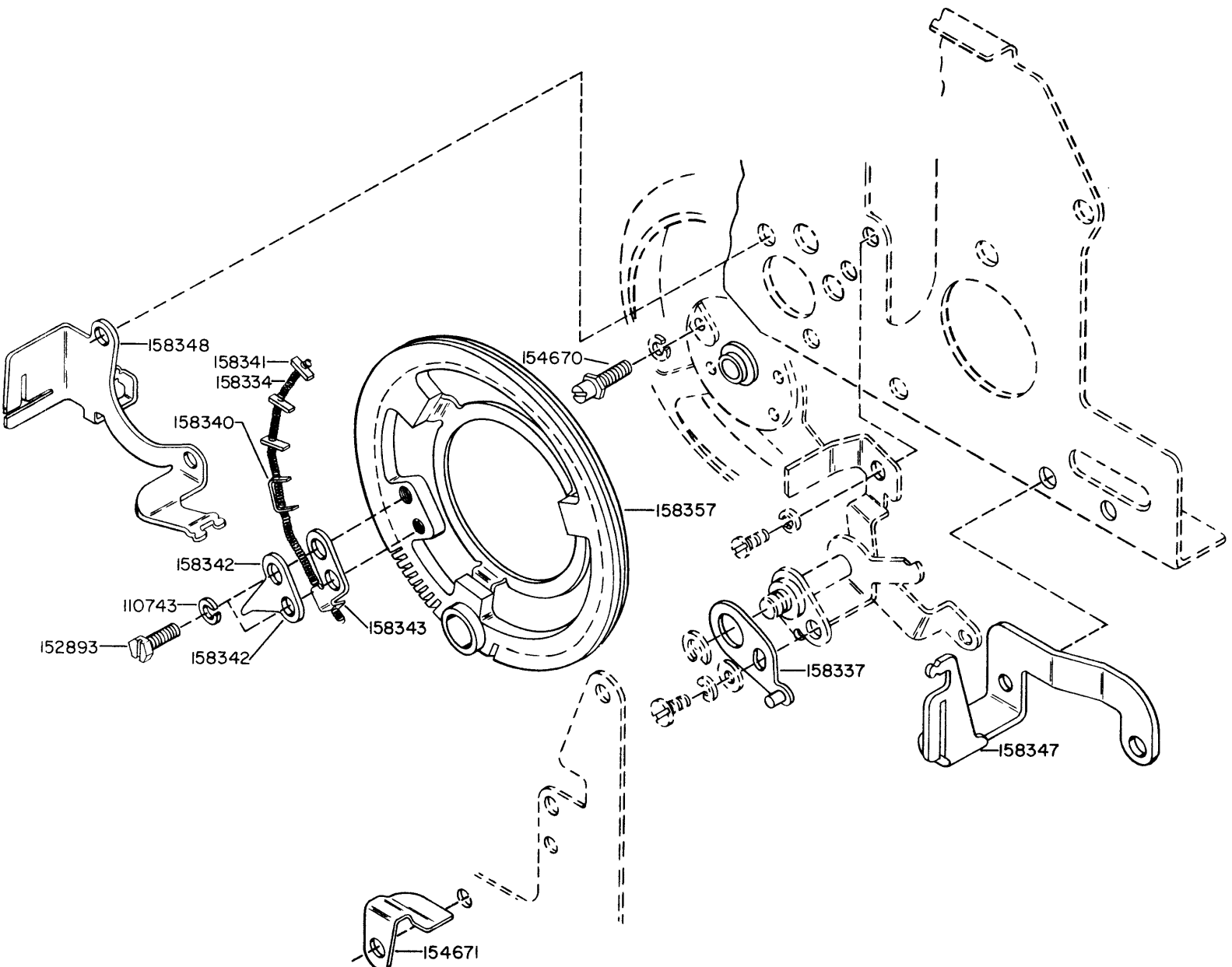
FIGURE 3-85. 154785 MODIFICATION KIT TO PROVIDE UNIVERSAL CONTACTS  
 CHANGE II

1149B



SPECIFICATION 5864S

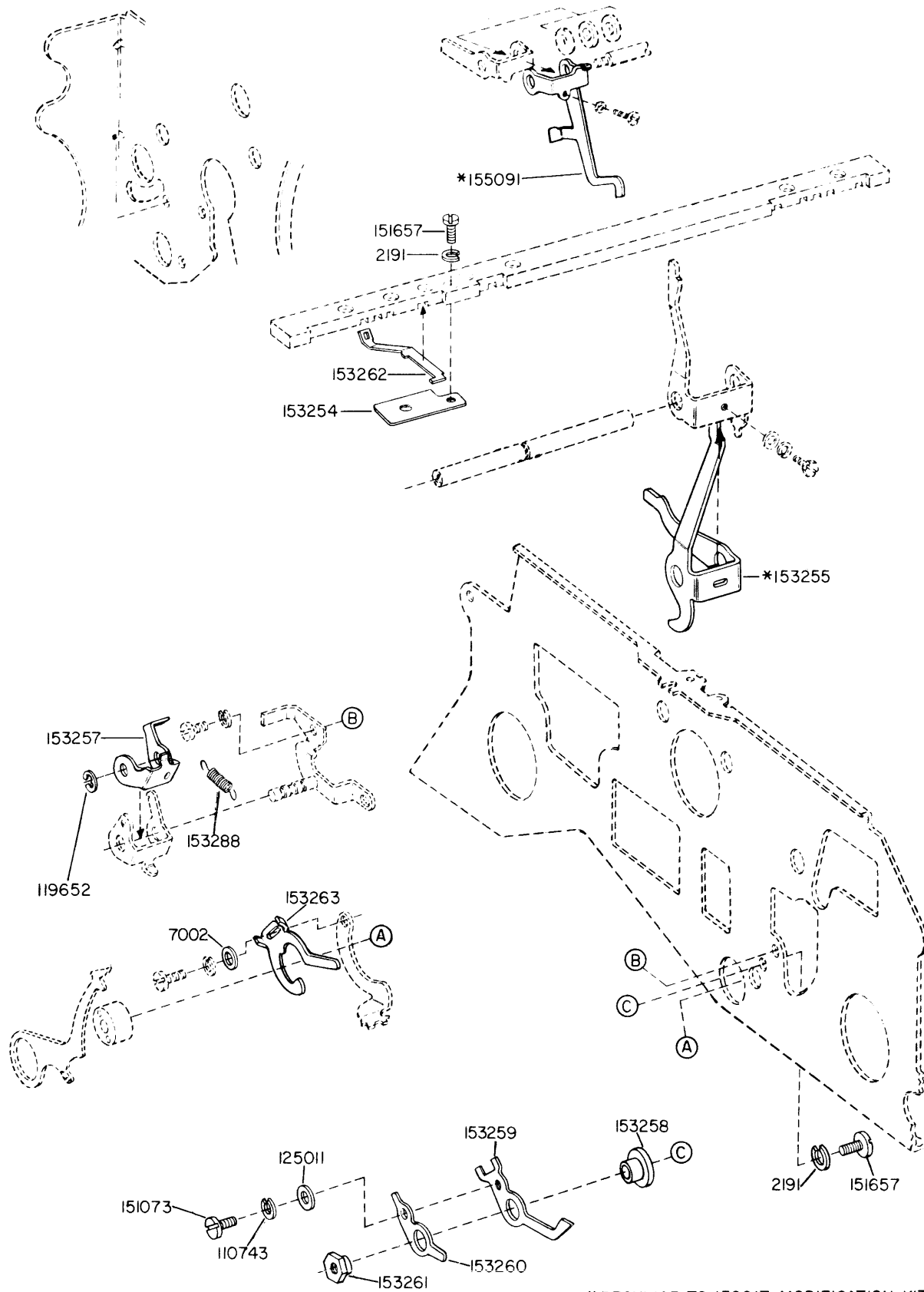
FIGURE 3-86. 157508 MODIFICATION KIT TO PROVIDE HORIZONTAL TABULATION  
(CONTINUED ON NEXT PAGE)



SPECIFICATION 58645

FIGURE 3--87. 157508 MODIFICATION KIT TO PROVIDE HORIZONTAL TABULATION  
(CONTINUED FROM PRECEDING PAGE)

1149B



SPECIFICATION 5766S

\* PECULIAR TO 152917 MODIFICATION KIT

FIGURE 3-88. 152917 AND 157510 MODIFICATION KITS TO PROVIDE LOCAL BACK SPACE

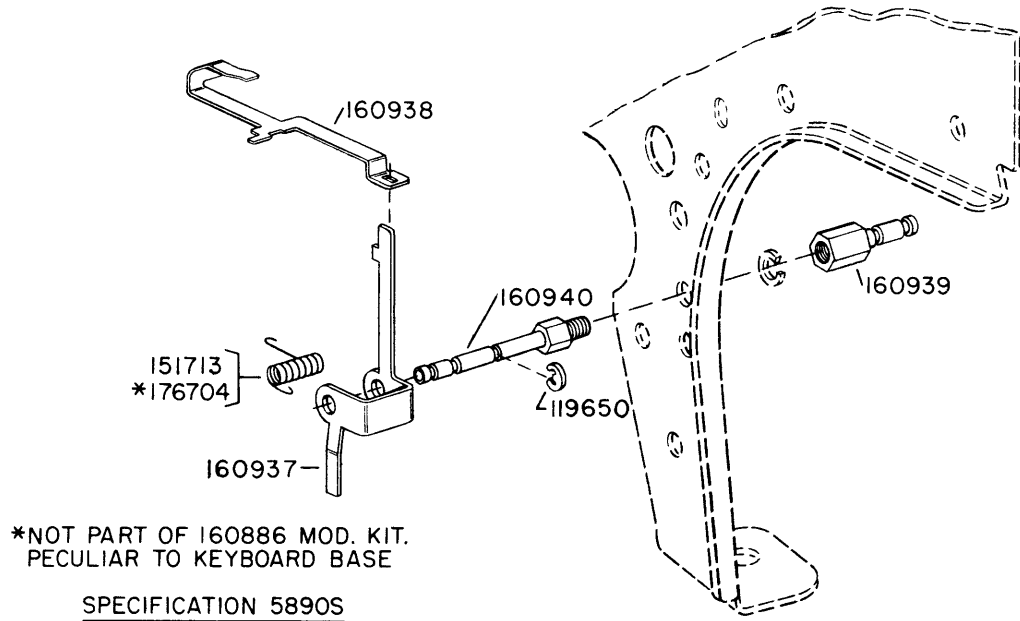


FIGURE 3-89. 160886 MODIFICATION KIT TO PROVIDE LOCAL FORM FEED-OUT (RECEIVING ONLY BASE)

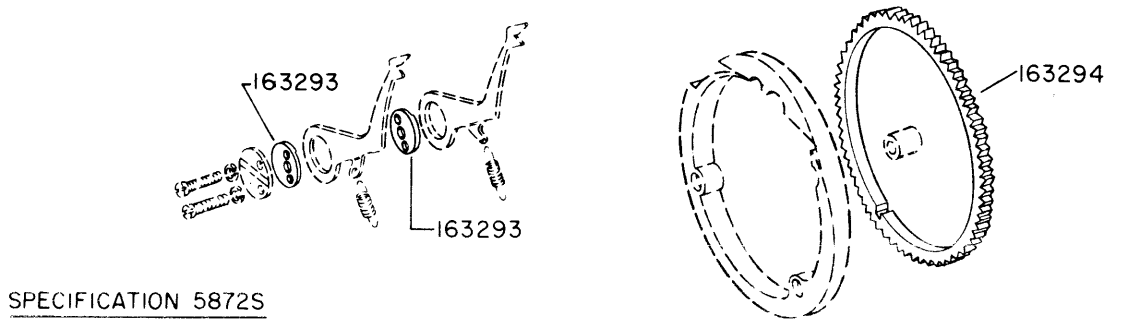
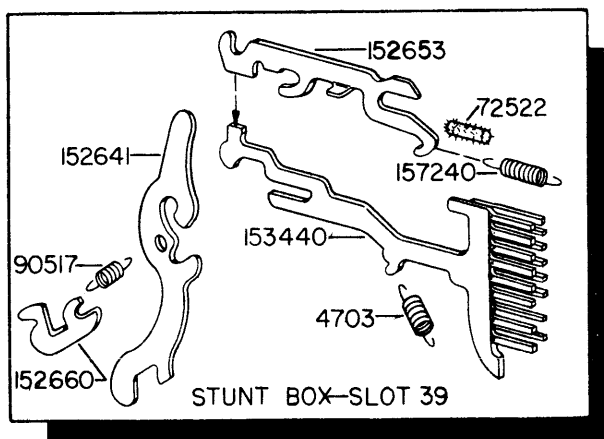
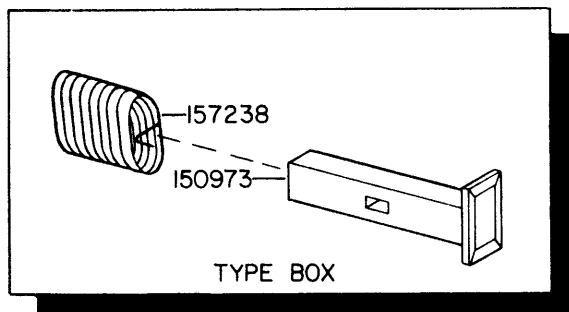
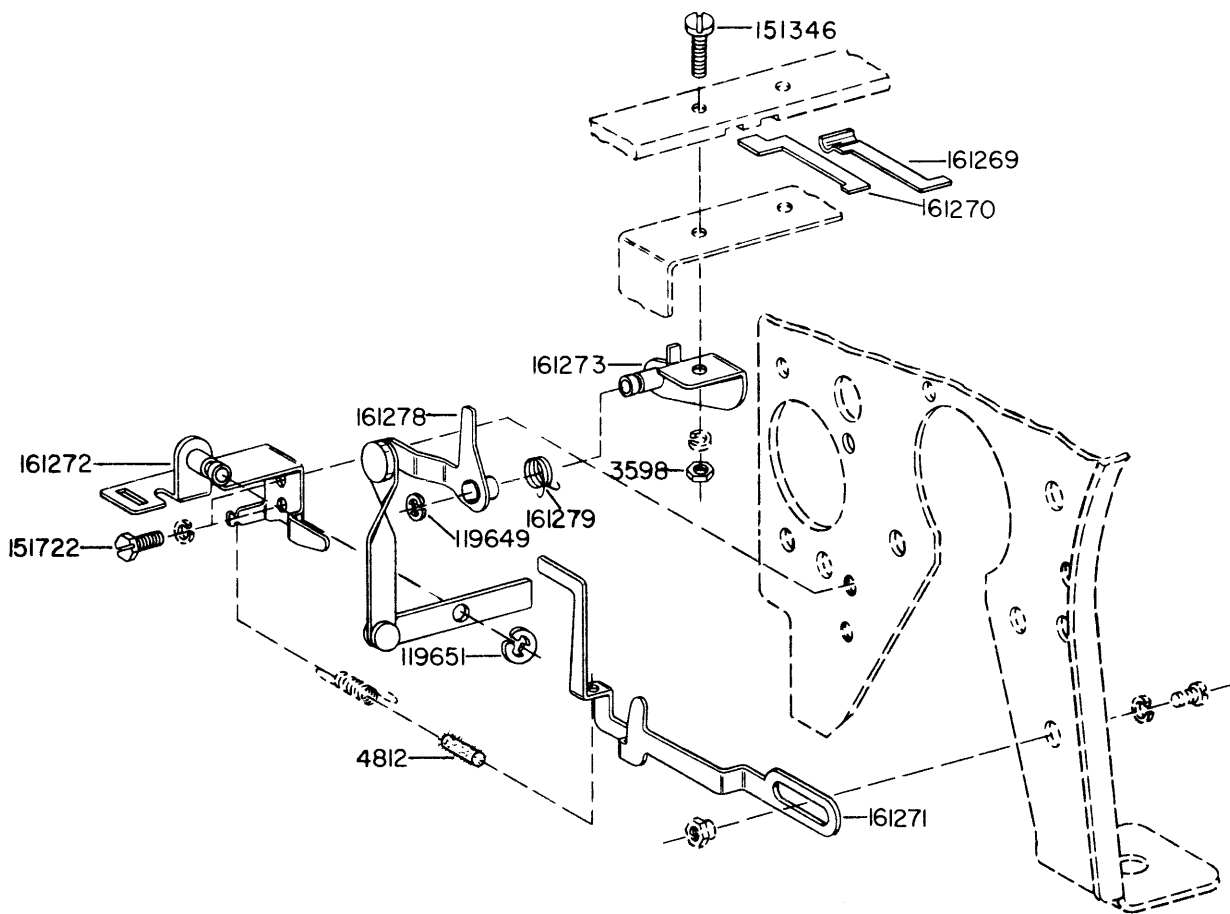
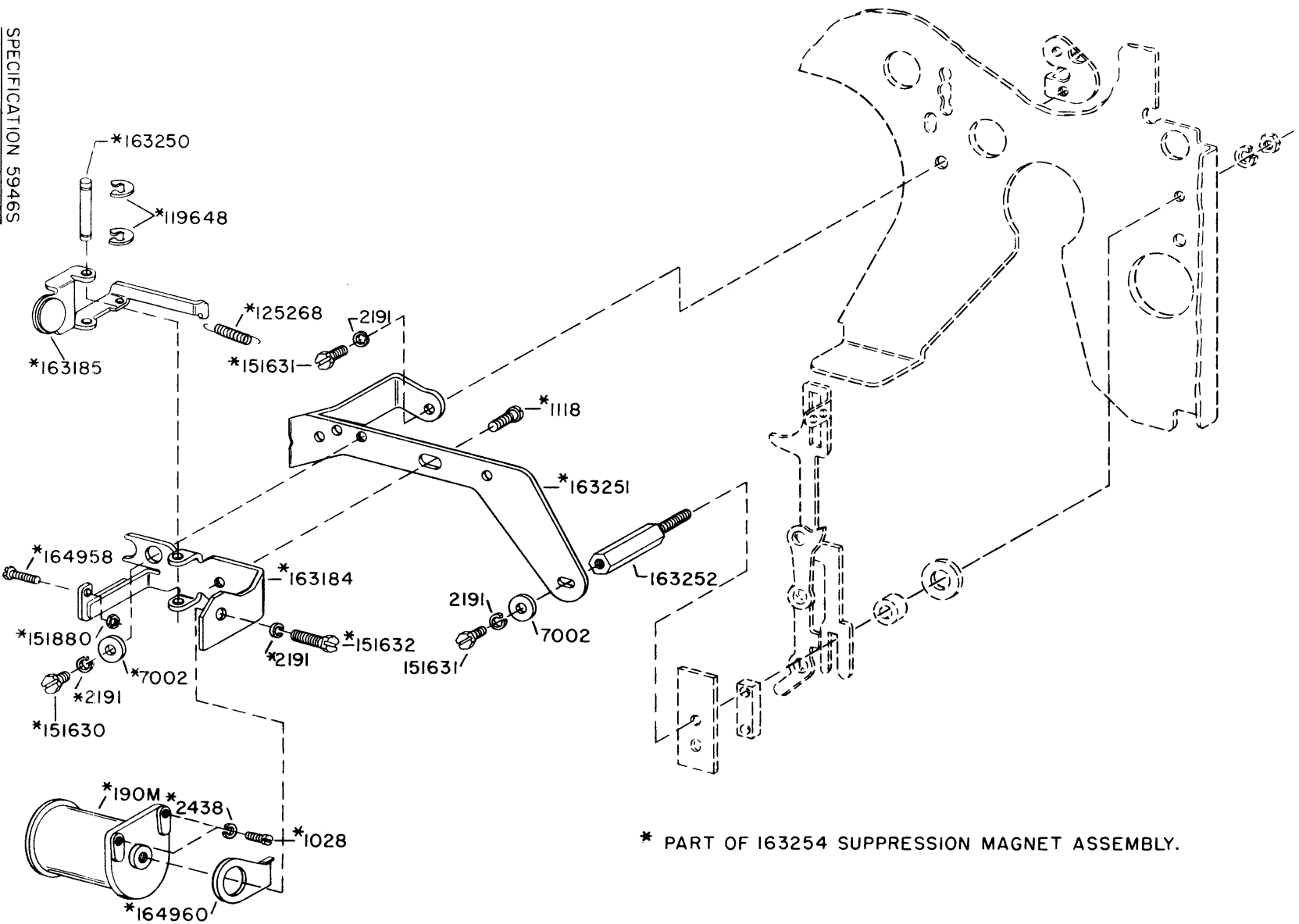


FIGURE 3-90 163292 MODIFICATION KIT TO PROVIDE 8 SPACES PER INCH MECHANISM



SPECIFICATION 5898S

FIGURE 3-91. 161280 MODIFICATION KIT TO PROVIDE ON-LINE REVERSE LINE FEED



SPECIFICATION 5946S

FIGURE 3-92. 163183 MODIFICATION KIT TO PROVIDE D.C. MAGNET OPERATED PRINT SUPPRESSION

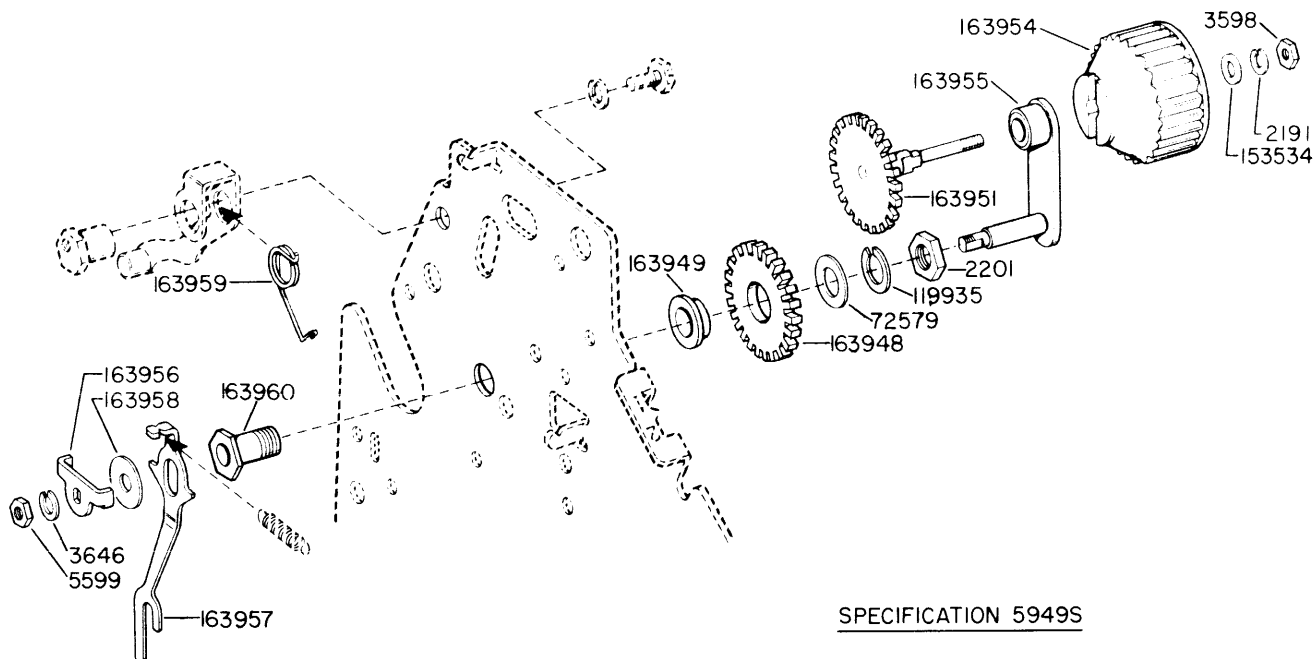


FIGURE 3-93. 163947 MODIFICATION KIT TO PROVIDE IMPROVED MANUAL PLATEN LINE FEED

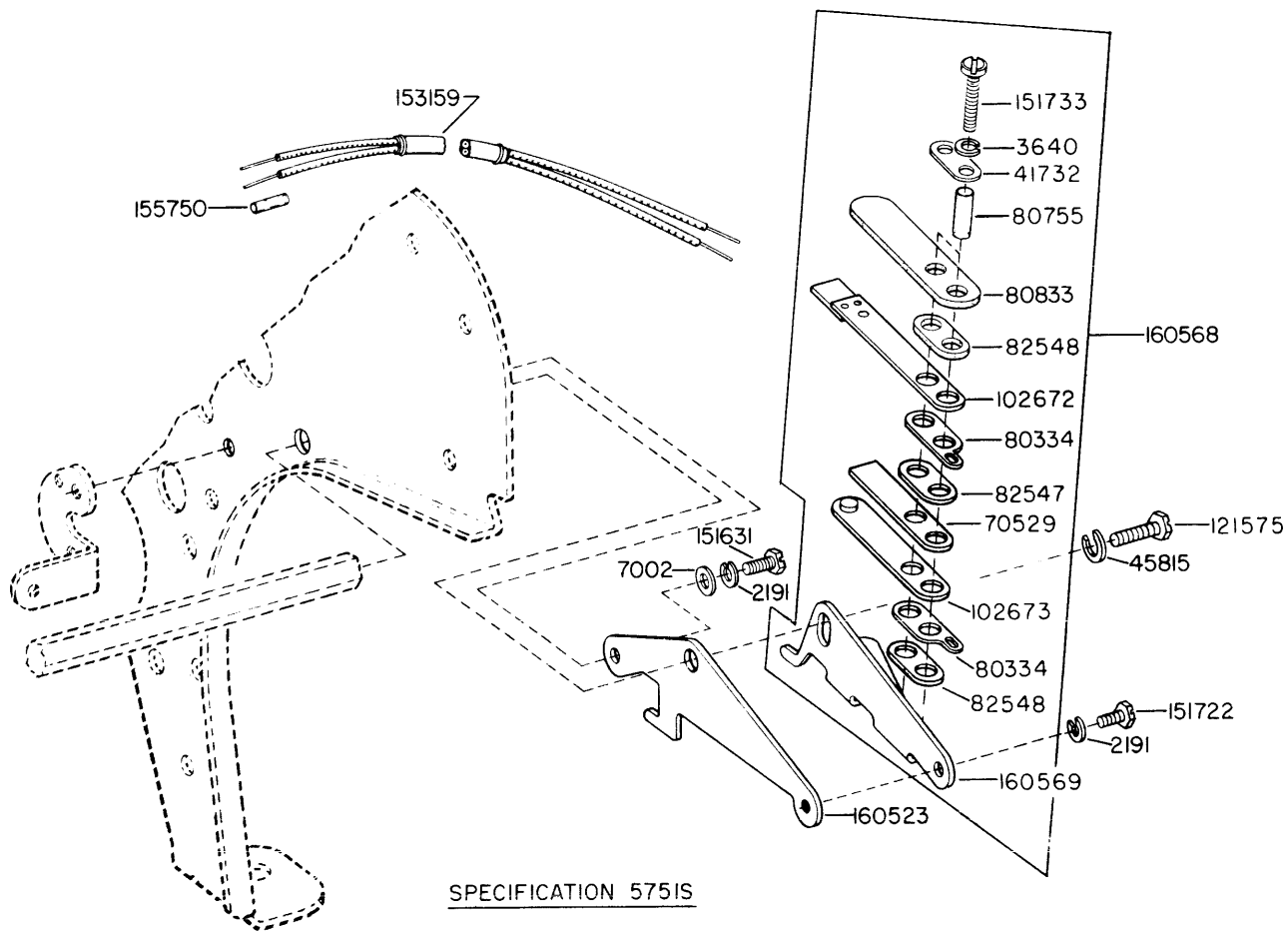
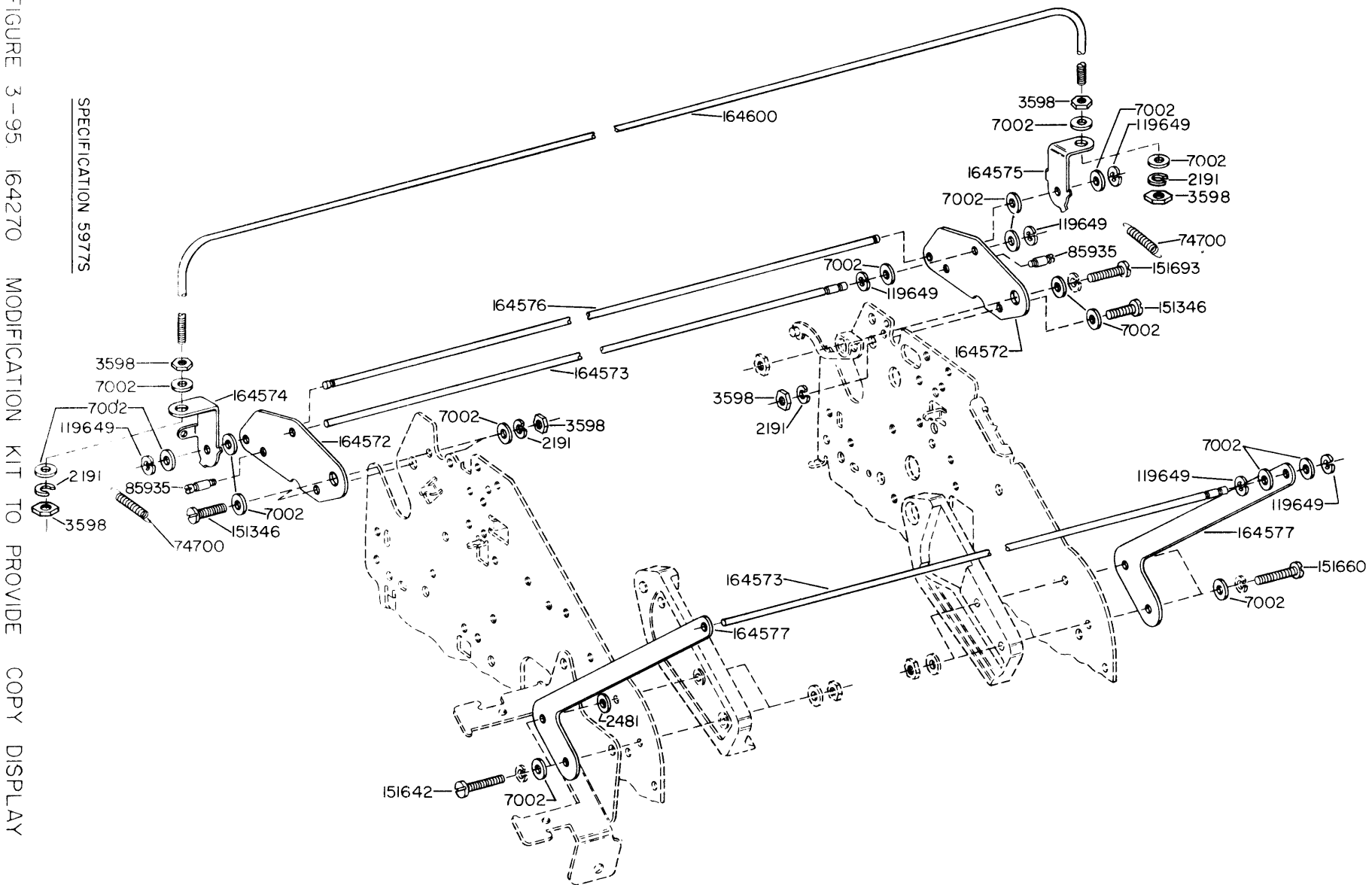


FIGURE 3-94. 163535 MODIFICATION KIT TO PROVIDE TRANSMITTER CONTROL FOR THE VERTICAL TABULATOR





SPECIFICATION 5977S

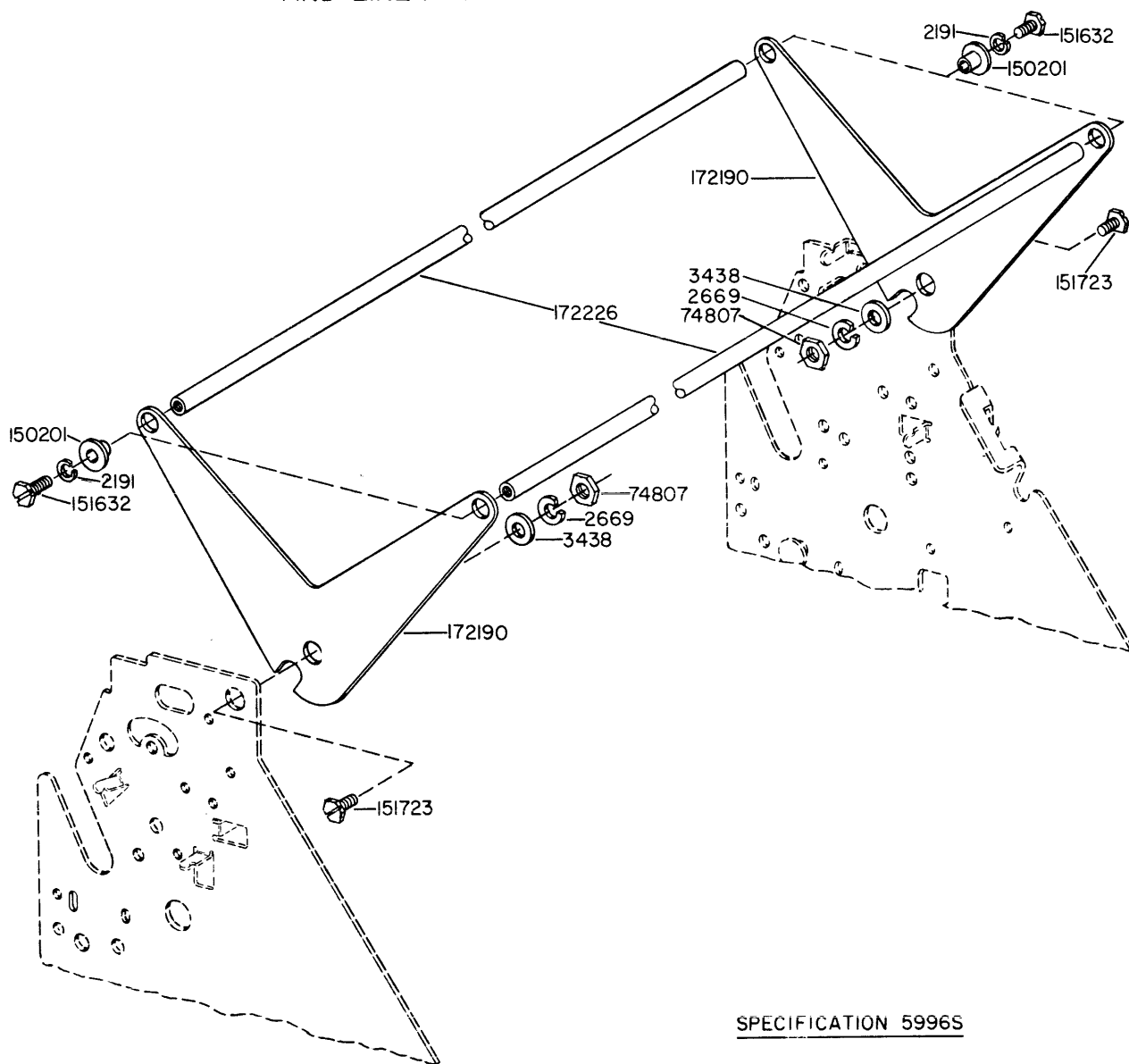
FIGURE 3-95 164270 MODIFICATION KIT TO PROVIDE COPY DISPLAY

CHANGE 9

1149B

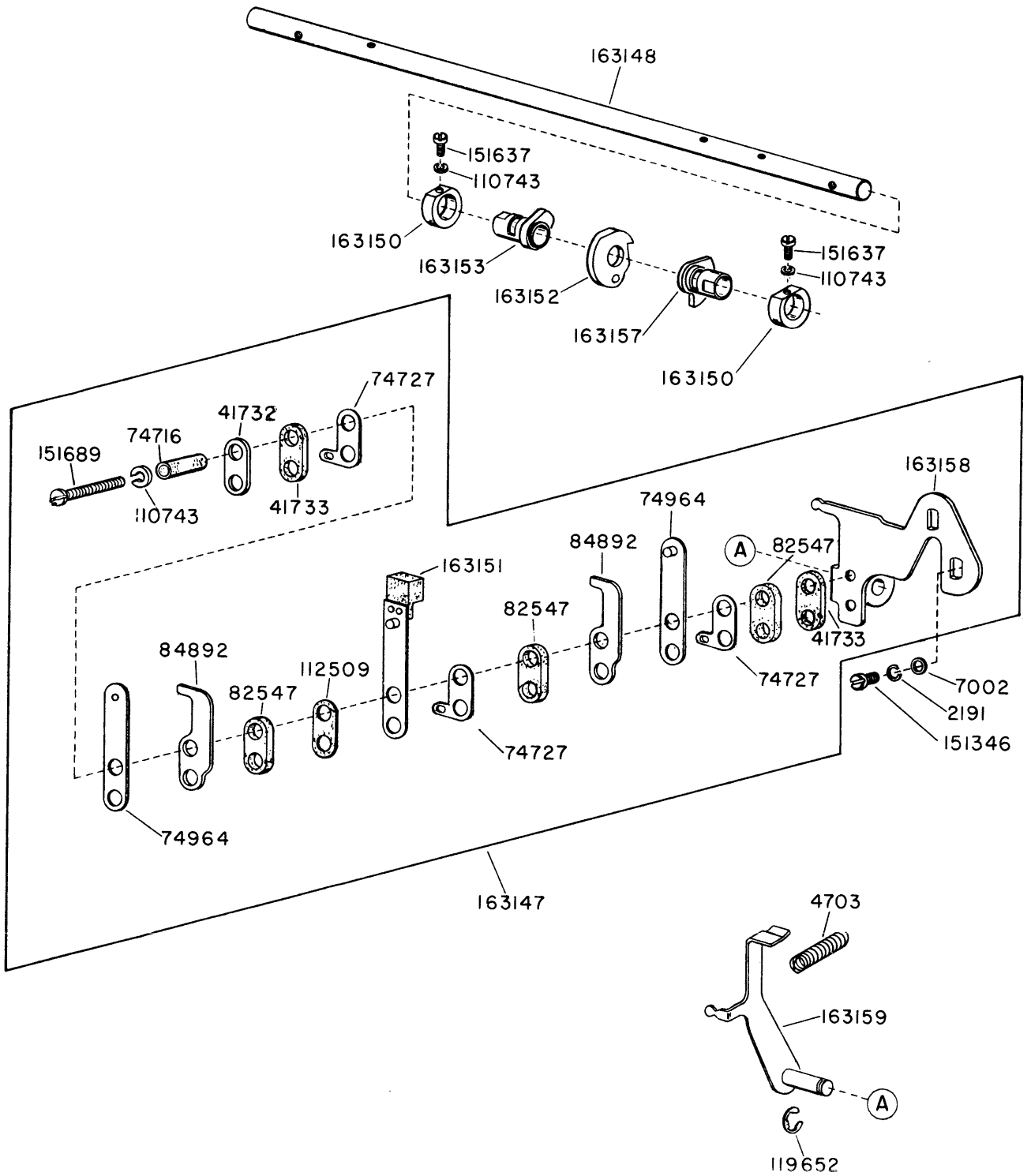
SPECIFICATION 5783S

FIGURE 3-96. 157514 MODIFICATION KIT TO PROVIDE AUTOMATIC CARRIAGE RETURN AND LINE FEED



SPECIFICATION 5996S

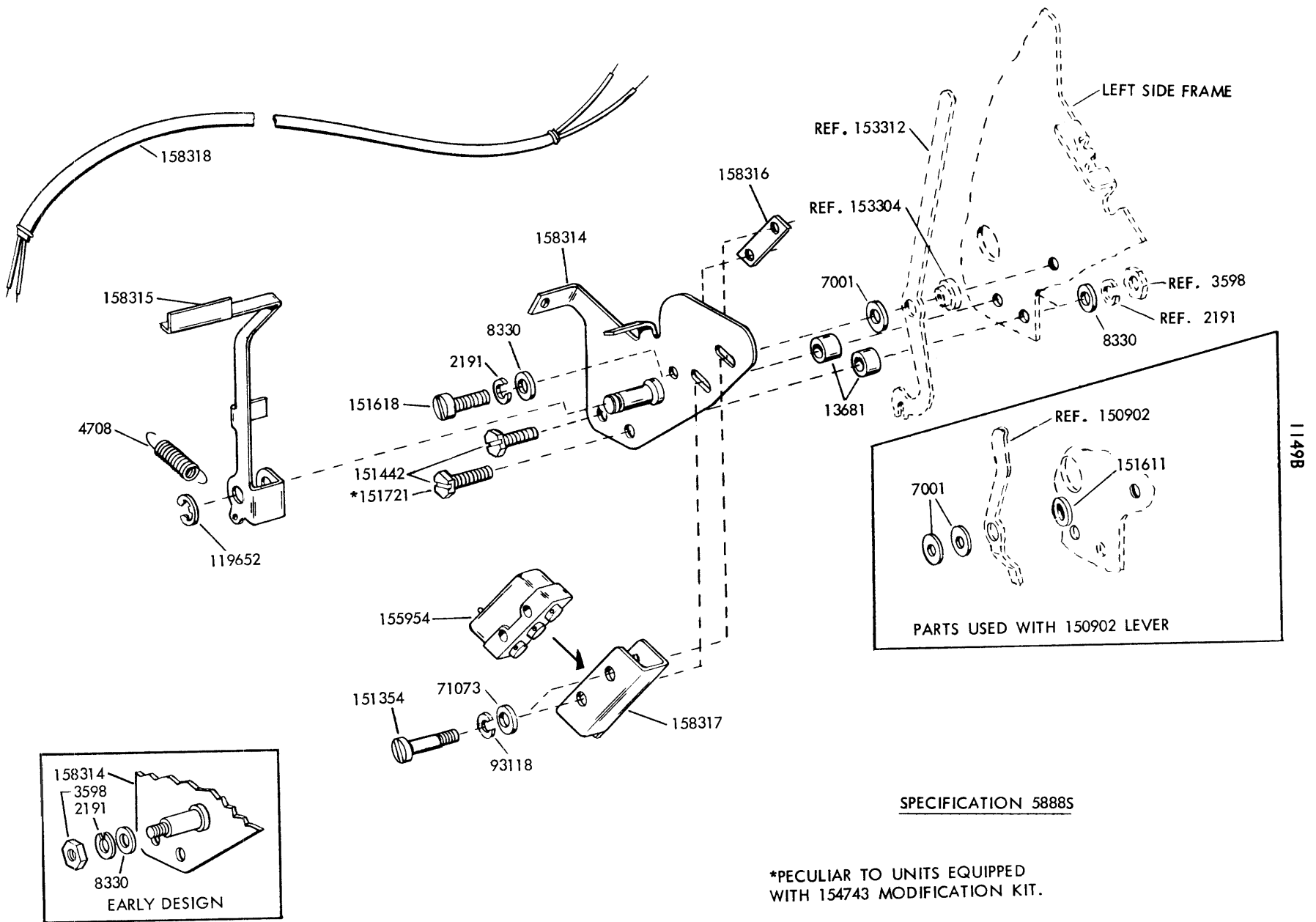
FIGURE 3-97. 172181 MODIFICATION KIT TO PROVIDE COPY DISPLAY



SPECIFICATION 5804S

FIGURE 3-98. 163146 MODIFICATION KIT TO PROVIDE UNIVERSAL CONTACT

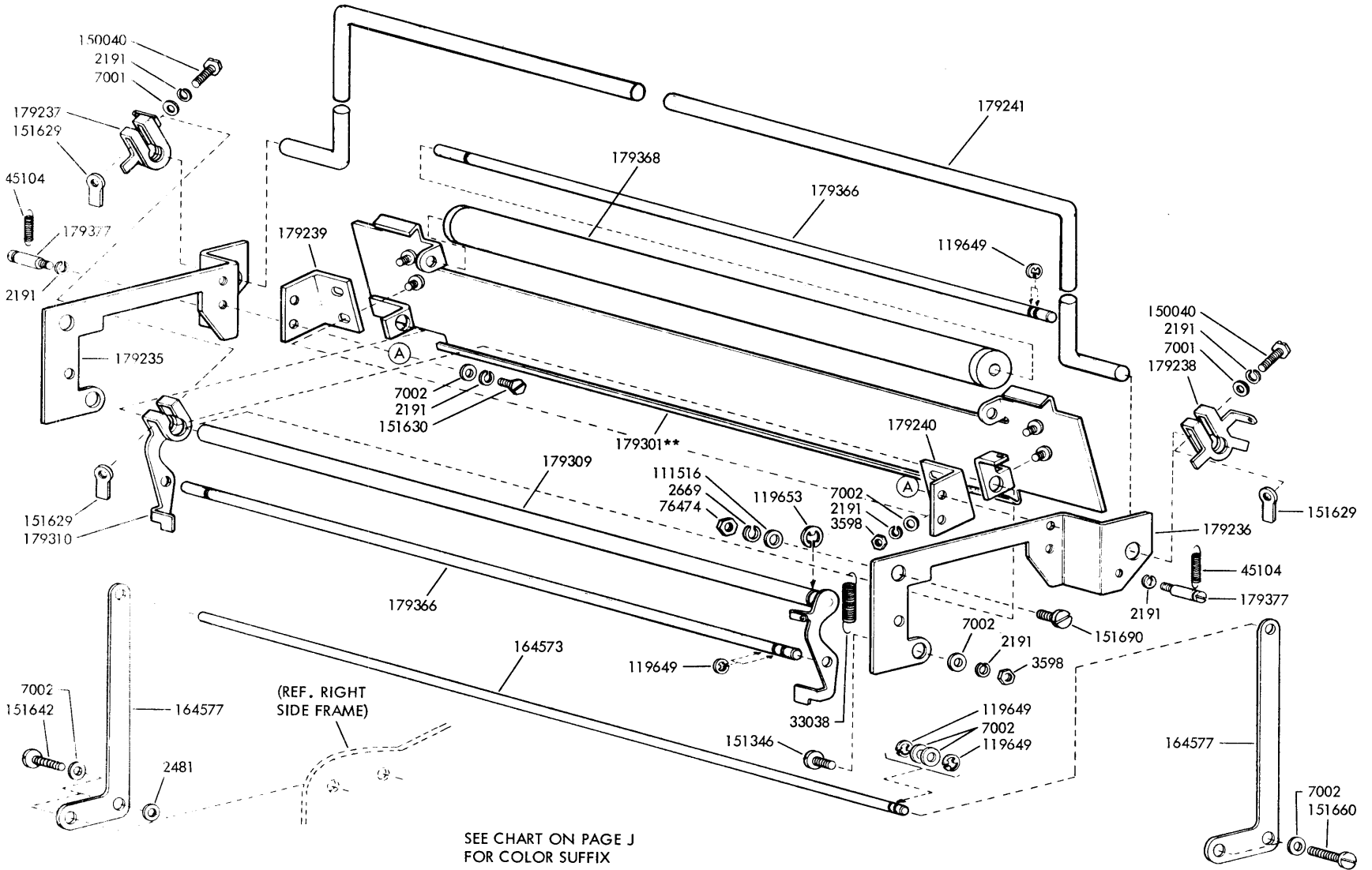
FIGURE 3-99. 159366 MODIFICATION KIT TO EQUIP A FRICTION FEED PRINTER WITH PAPER-OUT ALARM  
CHANGE II



SPECIFICATION 58885

\*PECULIAR TO UNITS EQUIPPED WITH 154743 MODIFICATION KIT.

FIGURE 3-100. 179369\*\* MODIFICATION KIT TO PROVIDE COPY DISPLAY



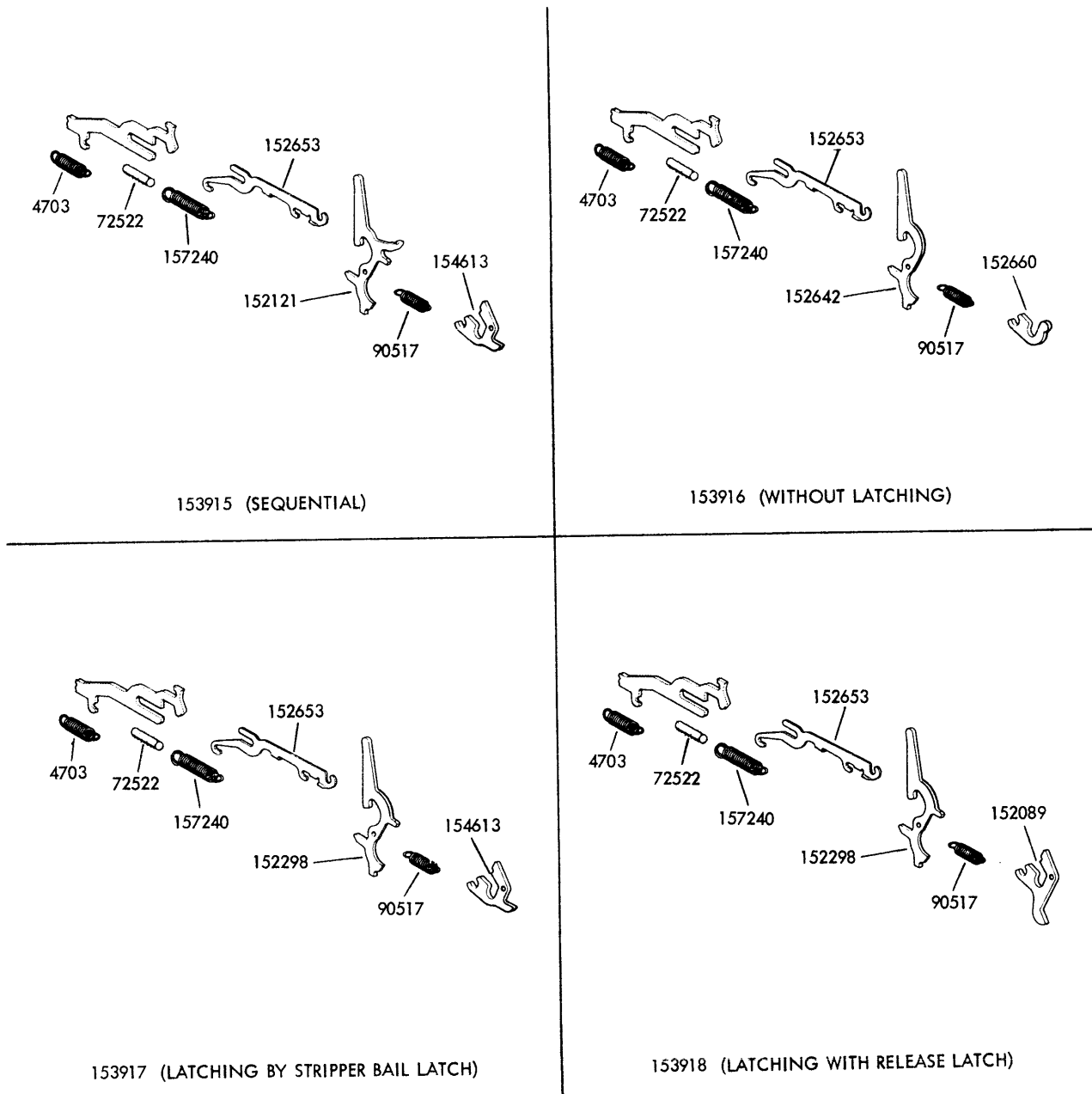


FIGURE 3-101. SELECTIVE CALLING FUNCTION LEVER MODIFICATION KITS

## NUMERICAL INDEX - SECTION 3

Part Number	Description and Page Number	Part Number	Description and Page Number	Part Number	Description and Page Number
190M	Coil, Magnet 3-89	55669	Spring 3-79	90490	Shim (.005) 3-8
209M	Coil, Magnet 3-80	70072	Washer, Lock 3-81	90504	Washer, Felt 3-26
250M	Coil, Magnet 3-35, 3-36	70388	Spring 3-22, 3-66	90517	Spring 3-49, 3-57, 3-60, 3-79, 3-88, 3-96
254M	Coil, Magnet 3-35	70529	Stiffener 3-90	90599	Shim 3-41
1010	Screw, Shoulder (6-40) 3-4	71073	Washer, Flat 3-94	90679	Washer, Felt 3-8, 3-9, 3-32
1028	Screw (4-40 x 17/32 Fil) 3-89	71681	Spool, Ribbon 3-37	90791	Washer, Lock 3-17, 3-18
1041	Screw (6-40 x 15/64 Fil) 3-72	72468	Spring 3-6	90819	Washer, Felt 3-10, 3-22
1118	Screw, Shoulder (6-40) 3-89	72522	Wick, Felt 3-49, 3-57, 3-60, 3-79, 3-88, 3-96	90951	Washer, Lock 3-71
1164	Screw (2-56 x 3/16 Fil) 3-17, 3-18	72579	Washer, Flat 3-5, 3-90	91120	Spring 3-79
1196	Screw, Shoulder (4-40) 3-11	73035	Spring 3-69	92682	Nut (4-40 Spl) 3-31
1214	Screw, Set (10-32) 3-28	73175	Washer, Lock 3-10, 3-22, 3-71	93117	Washer, Lock 3-63
1222	Screw (2-56 x 1/2 Fil) 3-58	73520	Wick, Felt 3-28	93118	Washer, Lock 3-2, 3-94
1272	Screw (6-40 x 11/16 Fil) 3-76	74272	Spring 3-24	93356	Washer, Felt 3-10, 3-11, 3-17, 3-19, 3-22, 3-29, 3-41, 3-59
1293	Screw (4-40 x 1/8 Fil) 3-38	74283	Washer, Spring 3-33	93507	Screw (4-40 x 3/4 Hex) 3-46
2034	Washer, Flat 3-33	74536	Screw (6-40 x 5/32 Fil) 3-8	93582	Washer, Flat 3-57, 3-79
2191	Washer, Lock (Sev.)	74547	Collar 3-22	93729	Wick, Felt 3-41
2201	Nut (5/16-32 Hex) 3-5, 3-90	74553	Wick, Felt 3-17	93758	Washer, Felt 3-8, 3-22, 3-64
2422	Washer, Lock 3-58	75700	Spring 3-91	93879	Oiler, Felt 3-8
2438	Washer, Flat 3-35, 3-89	74701	Spring 3-6, 3-22	94316	Yoke 3-80
2481	Washer, Flat 3-11, 3-91, 3-95	74712	Spring 3-8, 3-23	94317	Shaft 3-80
2539	Nut (3/8-32 Hex) 3-10, 3-22, 3-71	74716	Bushing 3-93	94674	Washer, Cup 3-41
2669	Washer, Lock 3-2, 3-8, 3-10, 3-15, 3-17, 3-24, 3-28, 3-33, 3-57, 3-79, 3-80, 3-92, 3-95	74722	Washer, Flat 3-14	94693	Wick, Felt 3-49, 3-57, 3-60, 3-79
3438	Washer, Flat 3-76, 3-92	74727	Terminal, Contact 3-93	95030	Nut (6-40 Shoulder) 3-56
3598	Nut (6-40 Hex) (Sev.)	74728	Terminal, Contact 3-81	95428	Spring 3-46, 3-47
3599	Nut (4-40 Hex) (Sev.)	74755	Washer, Felt 3-24	95827	Bushing 3-28, 3-67
3606	Nut (6-40 Hex) 3-32, 3-34, 3-47	74785	Roller 3-22	96717	Screw, Shoulder (4-40) 3-33
3646	Washer, Lock 3-8, 3-90	74798	Screw (6-40 x 31/64 Fil) 3-10	97481	Wick, Felt 3-10
3646	Washer, Lock 3-5, 3-90	74807	Nut (10-32 Hex) 3-92	98561	Bushing 3-72
3649	Washer, Flat 3-28, 3-31	74882	Spring 3-17	98726	Screw (3-48 x 1/4 Fil) 3-81
4586	Washer, Felt 3-8, 3-47	74964	Spring, Contact 3-93	100337	Spring 3-60
4703	Spring 3-53, 3-57, 3-69, 3-79, 3-88, 3-93, 3-96	75229	Spring 3-28, 3-77	100359	Screw (3-48 x 5/8 Fil) 3-71
4708	Spring 3-2, 3-94	75607	Washer, Flat 3-72	101386	Spring 3-5
4812	Wick, Felt 3-88	76379	Spring 3-15, 3-17	101796	Washer, Felt 3-8, 3-17, 3-28, 3-41
5599	Nut (8-32 Hex) 3-5, 3-90	76461	Washer, Flat 3-26	102672	Spring, Contact 3-90
5740	Screw (2-56 x 1/4 Fil) 3-46	76474	Nut (10-32 Hex) 3-95	102673	Spring, Contact 3-90
6800	Screw, Shoulder (6-40) 3-22	76800	Spring 3-13	103815	Collar, Set 3-59
7001	Washer, Flat 3-2, 3-94, 3-95	78533	Spring 3-33	103863	Spacer 3-48
7002	Washer, Flat (Sev.)	80334	Terminal, Contact 3-82, 3-90	104807	Washer, Flat 3-79
7036	Collar, Set 3-8	80342	Screw (6-40 x 11/32 Hex) 3-47, 3-83	105028	Wick, Felt 3-29
7603	Spring 3-22, 3-26	80581	Spring 3-8, 3-14	106281	Screw, Shoulder (4-40) 3-66
7655	Spring 3-59	80708	Clamp, Wire 3-63, 3-66, 3-80	107116	Washer, Lock 3-3, 3-68, 3-74, 3-76
7835	Spool w/Ribbon 3-38	80755	Bushing, Insulating 3-81, 3-90	108199	Wick, Felt 3-22, 3-29, 3-41, 3-72
7965	Spring 3-9, 3-68	80833	Guard, Contact Spring 3-90	110434	Screw (4-40 x 3/16 Fil) 3-2, 3-3, 3-13, 3-19, 3-27, 3-28, 3-33, 3-39, 3-42, 3-48, 3-71, 3-77
8330	Washer, Flat 3-2, 3-13, 3-22, 3-25, 3-31, 3-33, 3-41, 3-66, 3-71, 3-83, 3-94	80848	Spring 3-13, 3-14	110435	Nut (4-40 Hex) 3-31, 3-66
8449	Collar 3-22, 3-38	81731	Spring 3-28, 3-69, 3-77	110436	Spring 3-28, 3-67
13681	Washer, Flat 3-2, 3-94	81778	Screw (4-40 x 3/16 Fil) 3-35	110437	Spring 3-22, 3-59
22015	Spring 3-38, 3-48	82442	Spring 3-8	110743	Washer, Lock (Sev.)
31636	Spring 3-39, 3-64	82463	Spring 3-8, 3-37, 3-38, 3-59, 3-84	110747	Washer, Lock 3-6
33038	Spring 3-8, 3-59, 3-95	82547	Insulator 3-81, 3-82, 3-90, 3-93	110872	Spring 3-26
33828	Spring 3-29	82548	Insulator 3-81, 3-90	110879	Spring 3-84
34432	Washer, Flat 3-63, 3-81, 3-82	82860	Spring 3-72	111342	Spring 3-84
36273	Washer, Flat 3-29	82999	Spring 3-80	111355	Spring 3-8
41382	Spring 3-33	84575	Spring 3-8, 3-26, 3-27	111516	Washer, Flat 3-95
41675	Washer, Flat 3-59, 3-84	84598	Spring, Contact 3-82	112509	Insulator 3-93
41720	Spring, Contact 3-82	84758	Spring 3-59, 3-84	112626	Nut (10-32 Hex) 3-2, 3-8, 3-15, 3-17, 3-24, 3-28, 3-33, 3-57, 3-79
41732	Plate, Clamp 3-81, 3-82, 3-90, 3-93	84892	Stiffener 3-93	112627	Nut (2-56 Hex) 3-17, 3-18, 3-58
41733	Insulator 3-82, 3-93	85407	Spring 3-56	112629	Spring 3-84
42661	Spring 3-26, 3-37, 3-38, 3-57	85816	Wick, Felt 3-26	112633	Spring 3-41
42823	Washer, Flat 3-19, 3-20, 3-58	85935	Post, Spring 3-91	112634	Spring 3-37, 3-38
42827	Screw (3-48 x 1/4 Fil) 3-39	86079	Washer, Felt 3-72	112889	Screw (4-40 x 1/8 Fil) 3-59
45027	Spring 3-28	86304	Spring 3-8	114214	Bushing 3-5
45104	Spring 3-95	86835	Spring 3-29, 3-35, 3-68, 3-74	115122	Washer, Felt 3-15, 3-17
45815	Washer, Lock 3-90	86959	Bushing 3-82	119418	Washer, Flat 3-58
49420	Spring 3-41	87401	Spring 3-59, 3-84	119467	Insulator 3-58
55063	Spring 3-13	89096	Washer, Felt 3-20, 3-26	119648	Ring, Retaining (Sev.)
		89897	Nut (10-32 Hex) 3-28		
		90361	Washer, Felt 3-8, 3-15, 3-17, 3-37, 3-38		
		90432	Washer, Flat 3-15, 3-16, 3-17, 3-18		

1149B

NUMERICAL INDEX - SECTION 3 (Continued)

Part Number	Description and Page Number	Part Number	Description and Page Number	Part Number	Description and Page Number
119649	Ring, Retaining (Sev.)	150077	Sprina 3-43	150336	Bushina 3-28, 3-37, 3-38
119650	Ring, Retaining 3-87	150078	Nut, Shoulder (4-40) 3-42	150341	Post, Sprina 3-2
119651	Ring, Retaining (Sev.)	150079	Stud 3-42	150342	Screw, Shoulder (6-40) 3-14
119652	Ring, Retaining (Sev.)	150080	Screw, Shoulder (2-56) 3-17, 3-18	150343	Lever 3-38
119653	Ring, Retaining (Sev.)	150089	Screw (4-40 x 1/2 Fil) 3-28, 3-35, 3-82	150344	Lever 3-37
119935	Washer, Lock 3-5, 3-90	150091	Gear, Helical Driving (27T) 3-19	150348	Shaft 3-22
121120	Collar, Spacing 3-76	150096	Roller Assembly, Pressure 3-6	150349	Arm, Follower 3-22
121242	Clamp, Cable (1/8") 3-82	150097	Bar, Cross 3-7	150350	Shaft 3-22
121243	Clamp, Cable (3/16") 3-35, 3-47, 3-63, 3-83	150098	Bail, Pressure 3-7	150351	Stud, Eccentric 3-2
121244	Clamp, Cable (1/4") 3-47	150099	Guide, Paper 3-7	150352	Bushina 3-22
121245	Clamp, Cable (5/16") 3-47	150100	through	150353	Stud 3-2
121247	Clamp, Cable (7/16") 3-47	150162	Pallet, Type 3-43	150354	Arm, Trip 3-23
121248	Clamp, Cable (1/2") 3-74	150175	Stud 3-29	150355	Lever, Latch 3-22, 3-23
121249	Clamp, Cable (5/8") 3-76	150184	Link 3-28	150356	Lever, Trip 3-22, 3-23
121575	Screw (10-32 x 5/16 Hex) 3-90	150193	Hub 3-28	150358	Lever, Trip 3-22
121605	Bushing 3-66	150194	Plate 3-28	150361	Spacer 3-22, 3-80
122149	Screw (4-40 x 5/8 Hex) 3-48	150196	Bail 3-28	150363	Plate w/Roller and Shaft 3-15
124177	Washer, Lock 3-34	150197	Stud 3-24	150364	Stud, Eccentric 3-19
124681	Screw, Set (6-40) 3-6, 3-65	150201	Bushina 3-92	150365	Shaft, Rocker 3-15
125011	Washer, Flat (Sev.)	150202	Gear, Driven (18T) 3-28	150366	Bracket 3-15
125015	Washer, Flat (Sev.)	150203	Washer, Retaining 3-28	150367	Bracket 3-17
125126	Screw (2-56 x 9/32 Fil) 3-83	150204	Cam, Eccentric 3-28	150369	Link 3-15
125238	Spring 3-28	150206	Spacer 3-24	150370	Link 3-17
125268	Sprina 3-77, 3-89, 3-92	150208	Bail 3-29	150371	Slide 3-48
125802	Washer, Flat 3-14, 3-28, 3-48	150214	Stud, Bearing 3-8	150377	Arm 3-8
128002	Screw (2-56 x 3/16 Fil) 3-17	150215	Block, Guide 3-29	150380	Stud 3-17
128357	Rina, Retaining 3-13	150218	Bushina 3-29	150382	Block, Guide 3-15, 3-17
130696	Washer, Felt 3-83	150219	Screw (4-40 x 1/2 Sa) 3-26	150383	Spacer 3-15
135716	Sprina 3-22, 3-57, 3-59, 3-79	150222	Rope, Draw Wire 3-24	150384	Spacer 3-17
139555	Sprina 3-28	150228	Spacer 3-28	150386	Link 3-15
145301	Latch 3-49	150229	Retainer 3-28	150387	Link, Ribbon Drive 3-17
150000	Drum, Clutch 3-19, 3-20	150230	Plate 3-41	150390	Bushing 3-15, 3-16, 3-17, 3-18
150001	Drum, Clutch 3-20	150232	Retainer, Oil 3-29	150391	Spacer 3-21
150004	Cam, Code Bar Clutch 3-20	150233	Roller 3-28	150392	Bail 3-8
150013	Disk, Adjusting 3-19, 3-20	150234	Roller 3-28	150395	Screw, Shoulder (6-40) 3-15, 3-17
150014	Disk, Adjusting 3-19, 3-21	150235	Slide, Transfer 3-28	150396	Lever 3-15
150016	Spacer, Clutch 3-20	150237	Lever, Escapement 3-26	150397	Lever 3-17
150026	Lever, Shoe 3-19, 3-20	150241	Sprina 3-19, 3-20	150398	Stud, Pivot 3-10
150027	Lever, Shoe 3-19, 3-21	150244	Link 3-19	150399	Shaft 3-8
150029	Wick, Felt 3-19, 3-20	150245	Bracket 3-29	150401	Clamp 3-15
150030	Roller, Bearing 3-41	150247	Link 3-29	150410	Stud 3-15
150032	Disk, Clutch Cam (2 Stop) 3-21	150251	Wheel, Ratchet 3-24	150411	Washer, Flat 3-17
150033	Disk 3-19	150255	Bushina 3-26	150412	Arm, Follower 3-15
150034	Disk 3-21	150263	Bail 3-29	150413	Arm, Follower 3-17
150035	Disk 3-19	150265	Shaft 3-6	150414	Bushing 3-10
150038	Latch 3-41	150266	Lever, Guide 3-6	150419	Shaft 3-10
150039	Slide, Printing Arm 3-41	150267	Clamp 3-6	150420	Lever 3-17
150040	Screw (6-40 x 5/8 Fil) 3-13, 3-19, 3-20, 3-22, 3-71, 3-95	150269	Roller, Pressure 3-6	150423	Stud, Pivot 3-10
150043	Shoe 3-19, 3-20	150270	Link 3-6	150424	Blade 3-15, 3-16
150044	Shoe 3-19, 3-20	150271	Arm 3-6	150425	Lever, Lock 3-15, 3-17
150045	Bearing, Sleeve 3-19, 3-21	150274	Bracket, Clamp 3-6	150428	Lever 3-15
150046	Bearing 3-19	150276	Lever 3-6	150429	Stud, Eccentric 3-15, 3-17
150047	Bearing 3-20	150285	Bar, Tie 3-39, 3-40	150431	Lever, Trip 3-22
150048	Sprina 3-33	150288	Bracket 3-39	150434	Bail, Transfer 3-27
150049	Spacer, Clutch 3-21	150289	Stud 3-39	150436	Bushing 3-6, 3-13, 3-28
150050	Spacer, Clutch 3-20	150291	Slide 3-48	150438	Bellcrank 3-28, 3-67
150051	Cam, Eccentric 3-20	150293	Plate, Retaining 3-39	150440	Hub 3-19
150052	Cam, Eccentric 3-21	150296	Fork 3-48	150441	Gear, Helical Driven (12T) 3-19
150053	Bracket 3-41	150298	Bushing 3-48	150444	Lever, Trip Shaft 3-22
150054	Bail w/Roller 3-41	150301	Plate, Retaining 3-39	150447	Arm 3-31
150055	Stud 3-11, 3-31	150302	Shim 3-39	150450	Arm 3-31
150056	Arm 3-20	150304	Bracket, Guide 3-39	150451	Link 3-32
150059	Bail 3-41	150310	Lever, Ribbon 3-38	150452	Bearing 3-31
150061	Head, Print Hammer 3-41	150311	Lever, Ribbon 3-37	150453	Shaft 3-31
150064	Stud 3-41	150318	Stud 3-14	150471	Stud 3-31
150065	Bracket, Stop 3-41	150327	Roller 3-37, 3-38	150475	Bracket, Backstop 3-31
150068	Arm 3-41	150335	Gear, Spur (12T) 3-38	150479	Stud 3-33
150075	Latch 3-18			150481	Shaft 3-31, 3-65
				150482	Plate 3-31
				150507	Spring 3-31



## NUMERICAL INDEX - SECTION 3 (Continued)

Part Number	Description and Page Number	Part Number	Description and Page Number	Part Number	Description and Page Number
150525	Bracket 3-32	150728	Rail 3-26	150963	Plate, Retaining 3-48
150531	Bracket 3-27	150731	Slide 3-28	150969	Spring 3-2, 3-13
150535	Spring 3-39	150732	Slide 3-28	150970	Bearing 3-19
150536	Spring 3-28	150733	Slide 3-28	150971	Cable Assembly 3-52
150537	Bearing, Ball 3-28, 3-39	150738	Guide 3-28	150973	Pallet, Dummy 3-43, 3-57, 3-60, 3-88
150538	Cylinder, Dashpot 3-28	150740	Plate 3-30	150975	Cup, Dashpot 3-28
150543	Screw (3-48 x 13/32 Fil) 3-46	150746	Bushing 3-28	150978	Screw (6-40 x 1-1/8 Fil) 3-31, 3-80
150544	Handle 3-46, 3-47	150748	Stud 3-29	150987	Spacer 3-28
150545	Bracket 3-3	150750	Plate 3-26	150990	Washer, Felt 3-10, 3-11, 3-31, 3-32
150546	Bracket 3-2	150751	Block, Guide 3-26	150991	Washer, Felt 3-12
150547	Shaft 3-46, 3-47	150752	Stud 3-29	150992	Stud 3-6
150549	Collar 3-19	150753	Roller 3-29	150998	Spacer 3-14
150553	Bushing, Fiber 3-48	150754	Roller 3-29	151073	Screw (4-40 x 5/32 Fil) 3-14, 3-70, 3-72, 3-86
150554	Plate 3-26	150755	Stud 3-29	151103	Spring 3-33
150557	Bracket, Lock Lever Guide 3-9, 3-68	150757	Arm 3-29	151152	Screw (4-40 x 3/16 Hex) 3-10, 3-26, 3-31, 3-39, 3-41, 3-64, 3-67
150558	Spring 3-29	150758	Pulley 3-29	151182	Washer, Insulating 3-29
150559	Spring 3-29	150770	Bellcrank 3-28	151222	Washer, Felt 3-11, 3-31, 3-47
150561	Arm 3-8, 3-9	150771	Bellcrank 3-28	151223	Screw, Shoulder (4-40) 3-17, 3-18
150563	Spring 3-31	150776	Lever, Lock 3-29	151329	Switch, Sensitive 3-58, 3-63
150569	Guide, Left 3-4	150777	Bail 3-29	151336	Oiler 3-33
150571	Plate, Spacing 3-48	150781	Stud 3-8, 3-9	151346	Screw (6-40 x 3/8 Fil) 3-2, 3-8, 3-10, 3-11, 3-13, 3-14, 3-19, 3-24, 3-25, 3-28, 3-37, 3-81, 3-88, 3-91, 3-93, 3-95
150572	Separator, Contact 3-48	150796	Disk 3-24	151354	Screw (2-56 x 15/32 Fil) 3-2, 3-63, 3-94
150573	Separator, Contact 3-48	150798	Wheel, Ratchet 3-24	151442	Screw (6-40 x 1/2 Hex) 3-2, 3-15, 3-94
150576	Spring, Contact 3-48	150800	Stud 3-26	151443	Eccentric 3-41
150579	Guide 3-4	150803	Spring	151602	Plate 3-15, 3-17
150585	Bar, Line Feed 3-14	150804	Finger, Paper 3-6	151603	Spacer 3-17, 3-35
150586	Lever 3-14	150805	Shim 3-26	151604	Block, Guide 3-15, 3-17
150587	Spring, Contact 3-48	150806	Plate 3-26	151606	Screw (10-32 x 1/4 Hex) 3-11, 3-28
150588	Spring, Contact 3-48	150807	Oiler, Felt 3-26	151607	Retainer, Spring 3-36
150598	Track, Printing 3-29	150809	Gear, Spur (32T) 3-14	151610	Washer, Flat 3-19, 3-41, 3-69
150642	Bellcrank 3-14	150811	Stud 3-17	151611	Bushing 3-41
150646	Screw, Shoulder (6-40) 3-13, 3-14	150815	Bushing 3-6	151612	Spacer 3-41
150647	Eccentric 3-14	150816	Lever 3-6	151618	Screw (6-40 x 7/16 Fil) 3-2, 3-24, 3-25, 3-39, 3-57, 3-66, 3-68, 3-72, 3-74, 3-79, 3-94
150648	Eccentric 3-14	150821	Spacer 3-37	151619	Bushing 3-24
150649	Washer, Spacing 3-14	150824	Track 3-17	151625	Strip 3-29
150650	Bushing 3-14	150826	Finger, Paper 3-6	151626	Terminal 3-35
150651	Gear, Spur (28T) 3-14	150827	Drum, Spring 3-24	151627	Rod 3-10
150652	Screw (6-40 x 37/64 Fil) 3-14	150830	Bushing, Shoulder 3-19, 3-21	151629	Nut (6-40 Lug) 3-13, 3-22, 3-31, 3-71, 3-83, 3-95
150654	Guide 3-2	150831	Ring, Retaining 3-19, 3-21	151630	Screw (6-40 x 1/4 Hex) 3-2, 3-8, 3-13, 3-17, 3-19, 3-20, 3-26, 3-28, 3-29, 3-31, 3-33, 3-37, 3-39, 3-41, 3-59, 3-80, 3-84, 3-89, 3-95
150656	Handwheel 3-14	150833	Platen Assembly 3-14	151631	Screw (6-40 x 5/16 Hex) 3-24, 3-31, 3-35, 3-61, 3-62, 3-89, 3-90
150658	Gear, Spur (21T) 3-14	150838	Ring, Retaining 3-24	151632	Screw (6-40 x 3/8 Hex) 3-13, 3-15, 3-16, 3-17, 3-18, 3-19, 3-26, 3-48, 3-59, 3-60, 3-66, 3-69, 3-84, 3-89, 3-92
150665	Gear, Spur (42T) 3-21	150840	Bracket, Guide 3-6	151633	Bearing, Ball 3-15, 3-20
150666	Gear, Spur (28T) 3-14	150841	Bearing 3-19, 3-21	151637	Screw (4-40 x 1/4 Fil) 3-3, 3-13, 3-14, 3-15, 3-17, 3-18, 3-24, 3-26, 3-28, 3-33, 3-37, 3-38, 3-46, 3-47, 3-48, 3-57, 3-58, 3-60, 3-61, 3-62, 3-64, 3-68, 3-74, 3-79, 3-93
150668	Collar, Spacing 3-28	150843	Plate 3-24	151640	Lever, Shoe 3-20
150669	Shim 3-28	150889	Lever, Trip 3-23	151642	Screw (6-40 x 3/4 Fil) 3-19, 3-20, 3-57, 3-73, 3-79, 3-91, 3-95
150670	Shim 3-28	150891	Block 3-17	151644	Spring 3-15, 3-17
150672	Bearing 3-28	150894	Bar 3-8		
150673	Shaft 3-28	150895	Arm, Trip 3-22		
150677	Pawl, Feed 3-28	150900	Bail, Detent 3-2		
150678	Pawl, Feed 3-28	150902	Lever 3-4		
150685	Plate 3-6	150903	Block, Left 3-10		
150687	Stud 3-33	150904	Block 3-10		
150689	Block, Guide 3-46	150907	Spindle, Paper 3-10		
150691	Link 3-26, 3-27	150910	Latch 3-56		
150692	Link 3-26, 3-27	150911	Bushing, Shoulder 3-14		
150694	Slide 3-28	150912	Screw, Shoulder (6-40) 3-14		
150705	Bushing 3-26	150913	Bail 3-9		
150709	Spacer 3-26	150915	Blade, Stripper 3-9		
150710	Screw (6-40 x 1-1/4 Fil) 3-26	150919	Arm 3-8		
150711	Washer, Flat 3-83	150923	Washer, Felt 3-22, 3-29, 3-41		
150712	Rope, Draw Wire 3-24	150926	Washer, Felt 3-26		
150714	Bearing, Sleeve 3-14	150927	Oiler, Felt 3-26		
150715	Gear, Spur (32T) 3-14	150929	Oiler, Felt 3-26		
150718	Platen 3-14	150930	Washer, Felt 3-8		
150719	Retainer 3-14	150931	Spacer 3-21		
150720	Retainer 3-14	150932	Bushing, Shoulder 3-37, 3-38		
150721	Arm 3-26	150935	Latch 3-56		
150722	Arm 3-26	150937	Lever 3-38		
150726	Link 3-26, 3-27	150953	Slide 3-26, 3-27		
150727	Link 3-26, 3-27	150961	Bushing, Eccentric 3-2		

## 1149B

## NUMERICAL INDEX - SECTION 3 (Continued)

Part Number	Description and Page Number	Part Number	Description and Page Number	Part Number	Description and Page Number
151657	Screw (6-40 x 1/4 Fil) 3-2, 3-3, 3-6, 3-8, 3-9, 3-12, 3-13, 3-17, 3-28, 3-31, 3-33, 3-37, 3-38, 3-39, 3-47, 3-48, 3-69, 3-71, 3-81, 3-86	151937	Box Assembly, Type 3-44	152462	Latch, Right 3-35, 3-68, 3-74
151658	Screw (6-40 x 5/16 Fil) 3-5, 3-8, 3-10, 3-13, 3-15, 3-24, 3-25, 3-28, 3-29, 3-31, 3-35, 3-38, 3-57, 3-68, 3-71, 3-79, 3-93	151938	Box Assembly, Type 3-44	152463	Latch, Left 3-35, 3-68, 3-74
151659	Screw (6-40 x 1/2 Fil) 3-38	151941	through	152464	Insulator 3-35, 3-74
151660	Screw (6-40 x 7/8 Fil) 3-62, 3-91, 3-95	151953	Pallet, Type 3-43	152466	Connector, Receptacle (20 Pt) 3-76
151661	Screw (6-40 x 1 Fil) 3-28	152089	Latch 3-49, 3-96	152467	Connector, Plug (20 Pt) 3-35, 3-68
151667	Roller 3-32	152121	Lever, Function 3-49, 3-96	152468	Cable 3-35
151668	Roller 3-31, 3-32	152127	Clip 3-46	152701	Guide, Ribbon 3-17, 3-18
151669	Stud 3-32	152129	Sorina 3-41	152502	Modification Kit 3-17, 3-18
151670	Bracket 3-32	152140	Bail 3-8	152503	Link 3-17
151676	Shim 3-32	152147	Bearina, Ball 3-17	152505	Stud 3-26
151683	Box Assembly, Type 3-44	152254	Wick, Felt 3-15, 3-17, 3-30	152507	Roller, Detent 3-26
151685	Screw (4-40 x 5/16 Fil) 3-10, 3-17, 3-19, 3-22, 3-24, 3-26, 3-28, 3-48, 3-59, 3-84	152255	Bar w/Retainer 3-39	152508	Bracket 3-26
151686	Screw (4-40 x 3/8 Fil) 3-6, 3-28, 3-35, 3-81	152256	Bar, Code 3-39	152509	Bracket 3-26
151687	Screw (4-40 x 7/16 Fil) 3-48, 3-83	152257	Sorina 3-39	152510	Lever, Detent 3-26
151688	Screw (4-40 x 5/8 Fil) 3-19, 3-35, 3-47, 3-71, 3-80	152298	Lever, Function 3-49, 3-96	152511	Guide 3-26
151689	Screw (4-40 x 3/4 Fil) 3-6, 3-20, 3-47, 3-50, 3-51, 3-81	152299	Lever, Function 3-49	152514	Bail 3-8
151690	Screw (10-32 x 5/16 Fil) 3-19, 3-95	152302	Modification Kit 3-57	152515	Lever, Trip 3-8
151691	Screw (10-32 x 3/8 Fil) 3-26	152303	Modification Kit 3-58	152516	Slide 3-8
151692	Screw (6-40 x 3/16 Fil) 3-2, 3-3, 3-6, 3-8, 3-9, 3-10, 3-22, 3-26, 3-28, 3-34, 3-37, 3-41, 3-47, 3-66, 3-68, 3-69, 3-72	152304	Modification Kit 3-59, 3-60	152517	Arm, Trip Lever 3-23
151693	Screw (6-40 x 9/16 Fil) 3-19, 3-38, 3-91	152312	Modification Kit 3-61	152518	Bail 3-8
151695	Screw (6-40 x 5/8 Hex) 3-41	152315	Modification Kit 3-62	152521	Slide 3-26
151698	Spring 3-26, 3-27	152317	Modification Kit 3-63	152522	Lever 3-28
151700	Screw, Shoulder (6-40) 3-29	152337	Modification Kit 3-64	152523	Spring 3-37, 3-38
151701	Spring 3-33	152340	Modification Kit 3-65	152525	Hub 3-37, 3-38
151702	Nut (4-40 Hex) 3-46	152345	Modification Kit 3-66	152526	Plate 3-37
151703	Pin 3-6	152348	Modification Kit 3-67	152527	Plate 3-38
151709	Arm 3-41	152350	Modification Kit 3-68	152528	Ratchet, Ribbon 3-38
151713	Spring 3-9, 3-87	152357	Stud 3-49	152529	Ratchet, Ribbon 3-37
151714	Spring 3-33	152359	Arm 3-57	152536	Bail 3-29
151715	Spring 3-35	152360	Sleeve 3-57	152537	Clamp 3-19
151721	Screw (6-40 x 3/4 Hex) 3-10, 3-31, 3-83, 3-94	152400	Plate 3-33	152538	Plate, Front 3-28
151722	Screw (6-40 x 3/16 Hex) 3-22, 3-26, 3-35, 3-39, 3-59, 3-64, 3-69, 3-84, 3-88, 3-90	152401	Guide 3-33	152539	Guide 3-6
151723	Screw (10-32 x 3/8 Hex) 3-28, 3-92	152402	Guide 3-33	152541	Arm 3-15, 3-16
151728	Spring 3-19, 3-20	152403	Bracket 3-33	152542	Arm 3-17, 3-18
151731	Screw (4-40 x 7/8 Fil) 3-14	152404	Bracket 3-33	152543	Link 3-11
151732	Screw (4-40 x 11/32 Fil) 3-19, 3-69, 3-74	152405	Lever 3-33	152545	Lever 3-8
151733	Screw (4-40 x 9/16 Fil) 3-90	152406	Bracket 3-33	152546	Bracket 3-31
151734	Screw (4-40 x 3/8 Fil) 3-17	152407	Lever, Lock 3-33	152547	Shaft 3-46, 3-47
151736	Spring 3-19, 3-21	152409	Lever, Selecting 3-33	152548	Bar, Code 3-39
151737	Screw (4-40 x 11/64 Hex) 3-19, 3-20, 3-79, 3-81	152410	Bail, Reset 3-33	152549	Bar, Code 3-40
151738	Screw, Identification (4-40) 3-42	152411	Lever, Push 3-33	152550	Clamp 3-15
151739	Screw, Identification (6-40) 3-47	152412	Link 3-33	152551	Bar, Code 3-39
151794	Washer, Special 3-19, 3-21	152413	Bracket 3-36	152552	Bar, Code 3-39
151797	Cable 3-52	152415	Stud 3-35	152553	Bar, Code 3-39
151819	Jumper 3-35	152420	Lamination 3-35	152554	Bar, Code 3-39, 3-40
151880	Nut (4-40 Hex) 3-17, 3-28, 3-59, 3-81, 3-84, 3-89	152421	Bracket 3-35	152555	Shaft 3-11
151930	Box Assembly, Type 3-44	152422	Armature 3-36	152559	Plate, Pallet Box 3-43
151631	Box Assembly, Type 3-44	152423	Bracket 3-35	152560	Plate, Pallet Box 3-42
		152424	Plate, Stop 3-35	152563	Bracket 3-8
		152425	Post, Spring 3-35	152569	Linkage 3-30
		152426	Nut, Self Locking (6-40 Hex) 3-33	152570	Linkage 3-30
		152427	Latch 3-33	152571	Spacer 3-38
		152429	Rack, Sector 3-33	152572	Bracket 3-39
		152432	Arm, Stop 3-33	152573	Retainer 3-20
		152434	Plate 3-34	152574	Plate 3-39
		152435	Stud 3-34	152575	Bracket 3-39
		152436	Knob 3-33	152576	Bracket 3-39
		152437	Spacer 3-34	152579	Track 3-26
		152438	Bail 3-33	152580	Frame, Right Side 3-3
		152439	Shaft 3-34	152581	Frame, Left Side 3-2
		152440	Bushing 3-34	152582	Shaft 3-38
		152441	Washer, Flat 3-33, 3-83	152583	Bearing 3-31
		152445	Spring 3-33	152584	Lever 3-31
		152447	Shaft 3-20	152585	Lever 3-31
		152450	Cam, Selector 3-20	152586	Bracket 3-28
		152456	Holder, Wick 3-31	152587	Drum, Spacing 3-25
		152457	Wick, Felt 3-31	152588	Arm 3-25
		152458	Shield 3-35, 3-36	152589	Clamp 3-15
		152461	Bracket 3-35	152590	Lever, Cutout 3-25
				152591	Arm, Automatic CR & LF 3-25

## NUMERICAL INDEX - SECTION 3 (Continued)

Part Number	Description and Page Number	Part Number	Description and Page Number	Part Number	Description and Page Number
152592	Guide 3-26	152888	Screw (4-40 x 7/16 Hex) 3-21	153242	Bracket 3-69
152593	Housing, Bearing 3-17	152889	Plate, Retainer 3-47	153254	Bracket 3-86
152595	Slide 3-26	152890	Washer, Flat 3-28	153255	Bail 3-8, 3-86
152596	Slide, Shift 3-28	152891	Spring 3-33	153256	Bracket 3-28
152597	Bail 3-28	152893	Screw (4-40 x 1/4 Hex) 3-8, 3-15, 3-32, 3-33, 3-57, 3-64, 3-85	153257	Bail 3-86
152598	Stud 3-29			153258	Bushing 3-86
152599	Stud 3-29	152896	Cable Assembly 3-52	153259	Arm 3-86
152626	Bracket 3-46	152897	Guide 3-34	153260	Plate 3-86
152627	Bracket 3-46	152913	Modification Kit 3-71	153261	Bushing, Threaded 3-86
152629	Washer, Friction 3-37	152915	Modification Kit 3-69	153262	Arm 3-86
152630	Shaft 3-37, 3-38	152917	Modification Kit 3-86	153263	Arm, Stop 3-86
152633	Plate, Mount'ing 3-48	152927	Bushing 3-57, 3-79	153267	Washer, Felt 3-69
152634	Washer, Flat 3-28, 3-67	152938	Spacer 3-57, 3-79	153287	Spring 3-69
152635	Lever, Transfer 3-31	152943	Screw, Spl (10-32) 3-57, 3-79	153288	Spring 3-86
152636	Lever, Transfer 3-31	152985	Bail 3-57	153291	Arm 3-47
152637	Lever, Transfer 3-31	153071	Slide 3-48	153292	Plate 3-20
152638	Lever, Transfer 3-31	153073	Link 3-48	153293	Spacer 3-20
152639	Lever, Transfer 3-31	153074	Link 3-48	153294	Cam 3-47
152640	Lever, Transfer 3-31	153076	Bushing, Shoulder 3-71	153295	Shaft 3-47
152641	Lever, Function 3-49, 3-57, 3-79, 3-88	153077	Bellcrank 3-71	153296	Eccentric 3-20
152642	Lever, Function 3-49, 3-60, 3-96	153078	Bushing, Shoulder 3-71	153298	Bracket, Right 3-47
152643	Guide 3-46	153079	Bushing, Bearing 3-71	153299	Bracket, Left 3-47
152644	Bracket 3-38	153080	Shaft 3-71	153300	Arm 3-20
152646	Lever, Reversing 3-38	153081	Lever 3-71	153301	Arm 3-47
152647	Lever, Reversing 3-37	153082	Lever 3-71	153302	Blade, Bail 3-47
152648	Stud 3-37	153083	Bracket 3-71	153303	Slide, Stripper 3-47
152651	Plate, Guide 3-46, 3-47	153084	Spacer 3-48	153304	Bushing, Shoulder 3-2
152652	Bar, Guide 3-46, 3-47	153139	Box Assembly, Type 3-44	153305	Spring 3-8
152653	Pawl, Function 3-49, 3-57, 3-60, 3-79, 3-88, 3-96	153158	Plate, Nut 3-58	153310	Bail 3-8
152654	Plate, Guide 3-48	153159	Cable Assembly 3-58, 3-90	153311	Arm 3-8
152655	Plate, Adjusting 3-48	153160	through	153312	Lever 3-2
152656	Stud 3-48	153169	Bar, Function 3-53, 3-54	153314	Bracket 3-8
152658	Plate 3-48	153172	Spring 3-26	153315	Bracket 3-39, 3-67
152659	Lever, Function 3-49	153173	Plate, Clamp 3-26	153317	Bracket, Bearing 3-8
152660	Plate, Spring 3-49, 3-57, 3-60, 3-79, 3-88, 3-96	153174	Link 3-26	153318	Shaft 3-47
152662	Shaft 3-31	153175	Link 3-26	153319	Bar, Code 3-39, 3-67
152663	Guide 3-31	153180	Link 3-26	153320	Bar, Code 3-39
152665	through	153181	Link 3-26	153321	Bracket, Tie 3-39
152704	Bar, Function 3-53, 3-54, 3-79	153183	Slide 3-26	153322	Guide 3-47
152708	Lever, Keyboard Lock 3-9, 3-68	153184	Post 3-35	153323	Ring 3-20
152711	Bracket 3-9	153185	Gear, Idler (30T) 3-57, 3-79	153326	Blade 3-11
152716	Bail 3-11	153186	Arm, Slide 3-57	153331	Linkage 3-29
152717	Arm 3-21	153188	Screw, Shoulder (6-40) 3-57, 3-79	153332	Linkage 3-29
152721	Bar, Code 3-39, 3-40	153189	Spring 3-57, 3-79	153335	Plate 3-29
152723	Spring 3-6	153190	Arm w/Stud 3-57	153337	Bushing 3-29
152724	Spring 3-30	153191	Pointer 3-57, 3-79	153340	Spring 3-29
152725	Spring 3-6	153192	Spring 3-57, 3-79	153341	Spring 3-29
152726	Bushing 3-22	153193	Lever w/Stud 3-57	153342	Screw (6-40 x 15/16 Hex) 3-60
152742	Box Assembly, Type 3-44	153194	Bail 3-57	153343	Bushing, Eccentric 3-60
152752	Box Assembly, Type 3-44	153195	Plate w/Studs 3-57	153345	Arm w/Stud 3-60
152818	Lever, Detent 3-38	153196	Handwheel 3-57, 3-79	153346	Pawl 3-60
152819	Lever, Detent 3-37	153198	through	153347	Bracket 3-60
152820	Lever, Feed 3-38	153207	Gear, Spur 3-58, 3-78	153350	Shaft w/Brackets 3-60
152821	Lever, Feed 3-37	153208	through	153351	Clip, Stop 3-60
152823	Bracket 3-38	153217	Disk 3-58	153352	Spring 3-60
152824	Bracket 3-37	153228	Bellcrank 3-69	153355	Bracket 3-60
152826	Pin, Detent 3-37, 3-38	153229	Bushing, Shoulder 3-69	153356	Arm 3-60
152827	Bracket, Spool 3-38	153230	Bar, Line Feed 3-69	153358	Bracket w/Stud 3-60
152828	Bracket, Spool 3-37	153231	Bar, Line Feed 3-69	153359	Arm, Slide 3-59
152831	Clip 3-2, 3-3	153233	Guide 3-69	153360	Stud 3-59, 3-84
152832	Shaft 3-6	153234	Lever 3-69	153361	Post 3-59, 3-84
152834	Spring 3-37, 3-38	153235	Plate 3-19, 3-69	153364	Lever w/Bushing and Stud 3-59, 3-84
152871	Spring 3-14	153236	Gear, Spur (42T) 3-19, 3-69	153365	Arm, Cam 3-59, 3-84
152881	Box Assembly, Type 3-44	153237	Arm 3-69	153367	Arm 3-22, 3-59
152887	Screw (4-40 x 1/2 Hex) 3-19, 3-20, 3-21	153239	Roller 3-69	153368	Bail, Follower 3-22, 3-59
		153240	Retainer, Bearing 3-69	153375	Arm, Slide 3-59, 3-84
		153241	Link 3-69	153377	Bracket w/Studs 3-59, 3-84
				153378	Plate w/Pin 3-59
				153379	Plate, insulator 3-63

I 149B

NUMERICAL INDEX - SECTION 3 (Continued)

Part Number	Description and Page Number	Part Number	Description and Page Number	Part Number	Description and Page Number
153380	Bracket 3-63, 3-82	153606	Slide, Blocking 3-47	153912	Modification Kit 3-61
153382	Bail, Transfer 3-8, 3-59	153608	Fork 3-48	153915	Modification Kit 3-96
153383	Arm 3-8, 3-59	153609	Roller 3-48	153916	Modification Kit 3-96
153385	Plate 3-60	153610	Spindle, Paper 3-65	153917	Modification Kit 3-96
153386	Cable Assembly 3-63	153611	Disk, Paper Spindle 3-65	153918	Modification Kit 3-96
153387	Cable Assembly 3-82	153615	Arm 3-65	153919	Modification Kit 3-68
153396	Plate 3-61	153634	Collar 3-6, 3-65	153927	
153409		153643	Slide 3-48		through
	through	153644	Stud, Threaded 3-48	153936	Modification Kit 3-58
153435	Bar, Function 3-53, 3-54	153645	Plate, Guide 3-48	153945	Modification Kit 3-67
153436	Bar, Function 3-53, 3-55	153646	Bushing 3-48	153946	Modification 3-26
153437	Bar, Function 3-53, 3-55	153647	Plate 3-48	153975	Cable Assembly 3-52
153438	Bar, Function 3-53, 3-54	153652		154253	Stud 3-28
153440	Bar, Function 3-53, 3-54, 3-88		through	154373	Shield, Oil 3-83
153442	Screw (10-32 x 1/2 Hex) 3-10, 3-81, 3-83	153667	Guide, Form 3-70	154516	Ratchet 3-77, 3-92
153489	Detent 3-33	153670	Lever, Function 3-49	154517	Cam, Eccentric 3-77
153491	Plate 3-34	153676	Bail, Detent 3-13	154519	Lever, Latch 3-13
153508	Box Assembly, Type 3-44	153678	Bracket 3-13	154536	
153510	Box Assembly, Type 3-44	153682	Bracket 3-13		through
153513	Box Assembly, Type 3-44	153683	Bracket 3-13	154549	Pallet, Type 3-43
153514	Box Assembly, Type 3-44	153685	Arm, Stripper 3-13	154613	Latch 3-49, 3-96
153516	Box Assembly, Type 3-44	153686	Bearing, Sleeve 3-13	154614	Cam, Spacing 3-19, 3-59
153518	Box Assembly, Type 3-45	153687	Bearing, Sleeve 3-13	154616	Plate, Pallet Box 3-42
153520		153689	Gear, Spur (33T) 3-13	154620	Wick, Felt 3-33
	through	153690	Gear, Spur (28T) 3-13	154621	Retainer 3-33
153528	Bar, Function 3-53, 3-54	153692	Gear, Spur (33T) 3-13	154622	Lubricator 3-33
153530	Plate 3-17	153695	Pin 3-13	154623	Ring, Retaining 3-24
153531	Plate, Adjusting 3-17	153696	Spring 3-13	154624	Ring 3-24
153532	Screw, Adjusting (4-40) 3-17	153697	Bracket 3-13	154625	Ring 3-24
153534	Washer, Flat 3-5, 3-90	153698	Cam, Feed 3-13	154626	Ring 3-24, 3-67
153543	Armature 3-35	153699	Cam, Feed 3-13	154627	Drum, Spacing 3-24
153545	Bracket 3-35	153700	Hub, Platen 3-13	154638	Spring 3-41
153550	Link 3-10	153701		154639	Slide 3-48
153553	Roller 3-10		through	154642	Slide 3-48
153554	Bracket w/Stud 3-12	153717	Modification Kit 3-70	154643	Box Assembly, Type 3-45
153558	Link 3-10	153721	Arm 3-70	154645	Spacer 3-10
153560	Shaft 3-12	153722	Arm 3-70	154646	Lever, Function 3-49
153562	Shaft 3-10, 3-12	153726		154647	Lever, Function 3-49
153563	Bracket 3-66		through	154649	Arm 3-68
153564	Lever 3-66	153729	Guide w/Pins, Paper 3-70	154650	Clip 3-39
153565	Pin 3-66, 3-72	153751		154666	
153566	Bracket 3-64		through		through
153569	Arm 3-22	153767	Platen, Rubber 3-70	154669	Shaft 3-47
153570	Arm, Suppression 3-64	153771		154670	Screw (6-40 Spl) 3-60, 3-85
153573	Bail 3-10, 3-12		through	154671	Bracket 3-60, 3-85
153574	Roller 3-10, 3-12	153787	Bracket, Guide 3-70	154672	Bracket, Clip Stop 3-60
153576	Cam, Function 3-20	153791	Shaft 3-13	154673	Cable Assembly 3-2, 3-52
153577	Washer, Felt 3-10	153795	Slide 3-48	154688	Spring 3-10
153579	Bracket, Spring 3-12	153799	Screw (4-40 x 21/64 Hex) 3-13	154691	Clip 3-47
153580	Cam 3-12	153800	Cam 3-38	154692	Clip 3-47
153581	Handle 3-47	153806	Spring 3-22	154694	Disk 3-19, 3-20
153582	Screw, Shoulder (6-40) 3-8	153810	Guide, Ribbon 3-17	154698	Wick, Felt 3-59, 3-84
153583	Lever, Trip 3-22	153817	Screw (4-40 x 3/8 Hex) 3-26, 3-28	154727	Modification Kit 3-74
153584	Lever, Latch 3-22	153819	Washer, Lock 3-39	154742	Modification Kit 3-58, 3-75
153585	Clamp 3-10, 3-12	153820	Frame, Printing Carriage 3-41	154743	Modification Kit 3-62
153586	Guide 3-2	153823	Collar 3-20	154753	Modification Kit 3-76
153587	Guide 3-3	153824	Clamp 3-20	154755	Modification Kit 3-77
153588	Solenoid 3-66, 3-72	153838	Shaft 3-47	154760	
153592	Cable Assembly 3-52	153839	Screw (6-40 x 5/8 Hex) 3-13, 3-17, 3-35		through
153593	Cable Assembly 3-52		through	154769	Modification 3-78
153594	Cable Assembly 3-66	153841	Screw (6-40 x 9/16 Hex) 3-10, 3-15	154770	Modification Kit 3-79
153596	Fork w/Post 3-48	153883	Gear, Helical (33T) 3-19, 3-80	154771	Modification 3-79
153598	Pawl, Function 3-49	153884	Gear, Helical (111) 3-28, 3-80	154778	Modification Kit 3-80, 3-81
153600	Bracket, Spring 3-39, 3-64	153884	Plate w/Stud 3-59, 3-84	154780	Modification Kit 3-82
153601	Bushing, Shoulder 3-47	153894	Bail, Latch 3-59, 3-84	154785	Modification 3-83
153602	Plate 3-46	153896	Arm, Trip 3-59	154789	Modification Kit 3-10
153603	Nut (6-40 Spl) 3-39, 3-64	153899	Bracket, Guard 3-60	154872	Bracket 3-3, 3-68, 3-74
153604	Pawl, Function 3-49	153910	Modification 3-71	154873	Connector, Receptacle 3-76
153605	Bracket 3-39, 3-64	153911	Modification Kit 3-72, 3-73	155000	Cable 3-52
				155021	Plate 3-58

## NUMERICAL INDEX - SECTION 3 (Continued)

Part Number	Description and Page Number	Part Number	Description and Page Number	Part Number	Description and Page Number
155037	Keylever Assembly 3-60	155366	through	155854	Cam, Eccentric 3-77
155041	Plate 3-8	155370	Bar, Function 3-53, 3-55	155855	Pawl, Spacing 3-77
155042	Bracket 3-8	155432	through	155856	Pawl, Spacing 3-77
155044	Spacer 3-20	155479	Pallet, Type 3-45	155857	Retainer 3-77
155046	Screw (4-40 x 5/32 Hex) 3-20	155497	Box Assembly, Type 3-44	155859	Screw (4-40 x 1/8 Binding Head) 3-76
155047	Disk 3-20	155565	Arm, Right 3-13	155860	Screw (4-40 x 3/8 Round Head) 3-76
155049	Cable Assembly 3-52	155566	Arm, Left 3-13	155861	Washer, Lock 3-76
155051	Cable Assembly 3-76	155581	Spacer 3-56	155864	Shaft, Cam 3-10
155053	Connector, Plug (12 Pt ) 3-76	155582	Spacer 3-56	155865	Stud 3-10
155060	Slide, Stripper 3-47	155583	Spacer 3-56	155868	through
155061	Blade w/Studs 3-47	155584	Spacer 3-56	155870	Pallet, Type 3-44
155066	Cable Assembly 3-52	155586	Bracket 3-31	155877	Pallet, Type 3-44
155067	Cable Assembly 3-52	155587	Link w/Stud 3-31	155878	Pallet, Type 3-44
155068	Bracket 3-61	155589	Plate w/Stud 3-31	155885	through
155069	Bracket 3-61	155618	through	155891	Pallet, Type 3-45
155071	through	155673	Pallet, Type 3-45	155896	Finger, Paper 3-13
155076	Shaft 3-47	155693	Box Assembly, Type 3-45	155897	Finger, Paper 3-13
155081	Post, Spring 3-28	155697	Box Assembly, Type 3-44	155913	Block, Contact 3-51
155090	Lubricator Assembly 3-33	155699	Box Assembly, Type 3-44	155915	Plate, Contact 3-51
155091	Lever, Trip 3-86	155701	Box Assembly, Type 3-44	155916	Plate, Contact 3-51
155096	Plate w/Studs 3-33	155703	Box Assembly, Type 3-44	155917	through
155099	Screw, Shoulder (6-40) 3-47	155704	Box Assembly, Type 3-44	155929	Switch Assembly 3-51
155100	through	155705	Box Assembly, Type 3-45	155933	Plate, Guide 3-48
155125	Bar, Function 3-53, 3-54	155706	Box Assembly, Type 3-45	155934	Plate 3-48
155126	Bar, Function 3-53, 3-55	155707	Box Assembly, Type 3-45	155935	Fork w/Post 3-48
155127	through	155708	Box Assembly, Type 3-44	155936	Fork w/Post 3-48
155130	Bar, Function 3-53, 3-54	155709	Box Assembly, Type 3-45	155937	Fork w/Post 3-48
155131	Bar, Function 3-53, 3-55	155710	Box Assembly, Type 3-44	155938	through
155132	Bar, Function 3-53, 3-54	155713	Clip 3-49	155942	Slide 3-48
155133	Bar, Function 3-53, 3-55	155714	Bracket 3-82	155946	Slide 3-48
155134	Bar, Function 3-53, 3-55, 3-57, 3-79	155716	Plate w/Pin 3-84	155948	Slide 3-48
155135	Bar, Function 3-53, 3-55, 3-60	155721	Contact Assembly 3-82	155954	Switch 3-2, 3-94
155141	through	155736	Lever, Function 3-49	156093	Washer, Felt 3-14
155145	Bar, Function 3-53, 3-55	155737	Lever, Function 3-49	156536	Screw (4-40 x 1/8 Fil) 3-33
155159	Bar, Function 3-53, 3-54	155738	Blocking, Bail 3-49	156572	Washer, Felt 3-41
155176	through	155749	Cable Assembly 3-52	156574	Post, Spring 3-5
155180	Bar, Function 3-53, 3-55	155750	Sleeve, Insulating (3-32 x 1/2") 3-4, 3-26, 3-27, 3-36, 3-47	156632	Screw (6-40 x 13/62 Hex) 3-24
155191	through	155751	Sleeve, Insulating (1/8" x 1") 3-35, 3-47, 3-66, 3-83	156663	Insulator 3-83
155219	Bar, Function 3-53, 3-54	155752	Sleeve, Insulating (1/16" x 3/8") 3-47	157000	through
155246	Bar, Function 3-53, 3-55	155753	Sleeve, Insulating (1/8" x 1/2") 3-35, 3-47	157004	Box Assembly, Type 3-44
155347	Bar, Function 3-53, 3-55	155754	Sleeve, Insulating (1/16" x 1/2") 3-47	157007	Box Assembly, Type 3-44
155248	Bar, Function 3-53, 3-54	155755	Sleeve, Insulating (11/64" x 5/8") 3-47	157009	Box Assembly, Type 3-44
155249	Bar, Function 3-53, 3-54	155756	Nut (4-40 Spl) 3-57	157011	Box Assembly, Type 3-44
155250	Bar, Function 3-53, 3-54	155758	Gear, Spur (66T) 3-58	157013	Box, Assembly, Type 3-44
155286	through	155759	Gear, Spur (48T) 3-58	157015	Box Assembly, Type 3-44
155290	Bar, Function 3-53, 3-54	155765	Modification Kit 3-58	157017	Box Assembly, Type 3-44
155296	through	155767	Slide 3-48	157018	Box Assembly, Type 3-44
155300	Bar, Function 3-53, 3-54	155784	Cable Assembly 3-52	157030	Box Assembly, Type 3-44
155306	Bar, Function 3-53, 3-54	155788	Spring 3-83	157031	Disk 3-73
155307	Bar, Function 3-53, 3-54	155789	Cable Assembly 3-83	157032	Disk w/Post 3-73
155311	through	155790	Contact Assembly, Universal 3-83	157033	Plate, Cam 3-73
155315	Bar, Function 3-53, 3-54	155791	Link 3-83	157034	Lever, Trip 3-73
155326	through	155792	Arm w/Stud 3-83	157035	Lever w/Hub, Trip 3-73
155330	Bar, Function 3-53, 3-54	155793	Bracket, Mounting 3-83	157037	Spacer 3-73
155336	through	155795	Insulator 3-83	157038	Plate, Mounting 3-72
155340	Bar, Function 3-53, 3-54	155796	Shaft w/Link 3-31, 3-83	157039	Clip, Spring 3-72
		155797	Arm w/Pin and Contacts 3-83	157040	Bracket 3-72
		155798	Block w/Contacts, Terminal 3-83	157041	Bail 3-72
		155799	Terminal, Plate 3-83	157042	Bracket 3-72
		155852	Bellcrank 3-77	157043	Bracket, Adjusting 3-72
		155853	Ratchet 3-77	157044	Link 3-72
				157045	Cable Assembly 3-72
				157046	Bar 3-71
				157047	Lever 3-64

## NUMERICAL INDEX - SECTION 3 (Continued)

Part Number	Description and Page Number	Part Number	Description and Page Number	Part Number	Description and Page Number
157048	Lever 3-64	157644	through	158317	Insulator 3-2, 3-94
157049	Pin 3-64	157647	Pallet, Type 3-44, 3-45	158318	Cable Assembly 3-94
157070		157648	through	158334	Spring, Tension 3-84, 3-85
through		157657	Pallet, Type 3-44	158335	Stud 3-28, 3-84
157100	Switch Assembly 3-51	157659	Pallet, Type 3-44	158337	Plate w/Pin 3-85
157101		157660	Pallet, Type 3-44	158339	Arm w/Pin 3-84
through		157662	through	158340	Bracket 3-85
157106	Cable Assembly 3-52	157675	Pallet, Type 3-44	158341	Plate, Stop 3-85
157151	Bracket 3-68	157678	Pallet, Type 3-44	158342	Arm 3-85
157163	Spring 3-72	157716	through	158343	Bracket 3-85
157164	Slide 3-48	157724	Pallet, Type 3-44	158346	Lever w/Hub 3-84
157191	Bar, Line Feed 3-75	157726	Pallet, Type 3-44	158347	Bracket 3-85
157192	Eccentric, Line Feed Bar 3-75	157729	through	158348	Bracket 3-85
157193	Gear, Spur (44T) 3-75	157779	Pallet, Type 3-45	158349	Arm, Slide 3-84
157194	Retainer, Spring 3-35	157792	Pallet, Type 3-44	158351	Pawl w/Stud 3-84
157198	Bail, Platen Detent 3-75	157823	through	158352	Bail 3-22
157200	Spring 3-49, 3-57, 3-60, 3-79	157829	Pallet, Type 3-45	158353	Bail 3-22
157205	Lever, Function 3-49	157843	Cam 3-80	158354	Arm 3-22
157206	Lever, Function 3-49	157844	Plate, Spacer 3-80	158357	Ring w/Roller 3-85
157207	Lever, Function 3-49	157845	Plate 3-80	158365	Blade, Reset 3-10
157237	Shield 3-35	157846	Spacer, Shoulder 3-80	158447	Keylever Assembly 3-79
157238	Spring 3-42, 3-57, 3-60, 3-88	157847	Bracket, Spring 3-48	159362	Modification Kit 3-56
157240	Spring 3-49, 3-57, 3-60, 3-79, 3-88, 3-96	157849	Lever w/Stud 3-48	159366	Modification Kit 3-94
157241	Bracket, Roller 3-10	157850	Lever w/Stud 3-48	159395	Modification Kit 3-77
157243	Plate 3-48	157851	Plate, Spring 3-48	160192	through
157247	Bar w/Pin and Post 3-47	157852	Arm 3-48	160222	Switch Assembly 3-50
157251	Arm w/Pin 3-62	157854	Plate w/Studs 3-48	160486	Bail 3-79
157252	Bushing 3-62	157855	Plate, Guide 3-48	160489	Plate, Form Stop 3-78
157253	Lever 3-62	157856	Bracket 3-81	160490	Pawl w/Hub 3-79
157254	Bracket 3-62	157857	Spring 3-81	160491	Plate w/Stud 3-79
157255	Block 3-62	157858	Extension, Armature 3-81	160493	Plate w/Stud, Adjusting 3-79
157257	Block, Paper Spindle 3-62	157859	Shim 3-81	160495	Plate w/Stud and Hub 3-79
157258	Bar w/Post 3-47	157861	Lever, Start 3-81	160498	Plate w/Studs 3-79
157259	Relay 3-81	157862	Bracket, Guide 3-81	160499	Lever, Blocking 3-79
157261	Shaft 3-33	157863	Lever 3-81	160500	Lever, Blocking 3-79
157262	Bracket, Double Connector 3-74	157865	Plate 3-80	160502	Slide, Form Out 3-79
157263	Cable Assembly 3-81	157866	Bracket 3-80	160503	Slide, Form Out 3-79
157264	Cable Assembly 3-81	157867	Screw, Pilot 3-80	160505	through
157265	Cable Assembly 3-80	157868	Armature 3-80	160514	Disk, Retainer 3-78
157269	Cable Assembly 3-52	157869	Spacer 3-80	160523	Plate, Mounting 3-90
157272	Insulator 3-74	157870	Armature 3-80	160527	through
157273	Connector, Plug (35 Pt) 3-74	157871	Bracket 3-80	160536	Spring 3-78
157274	Clip 3-47	157873	Lever w/Bushing 3-80	160568	Contact Assembly 3-90
157275	Clip, Spring 3-47	157875	Bracket w/Stud 3-80	160569	Bracket 3-90
157286	Clamp, Platen 3-13	157876	Bracket 3-80	160572	Slide, Stripper 3-47
157289	Bar, Cross 3-6	157877	Bracket 3-80	160573	Blade w/Studs 3-47
157290	Bail, Pressure 3-6, 3-7	157884	Block, Contact 3-51	160574	Arm w/Stud 3-79
157291	Guide, Paper 3-6	157887	Bracket 3-80	160576	Slide, Stripper 3-47
157311	Wick, Oil 3-81	157888	Arm, Contact 3-50, 3-51	160577	Blade W/Studs 3-47
157398	Bar w/Pin and Post 3-47	157889	Spring, Contact 3-51	160578	Sleeve, Pinion 3-79
157508	Modification Kit 3-84, 3-85	157890	through	160584	Shield, Insulating 3-81
157509	Modification Kit 3-64	157893	Plate, Contact 3-51	160585	Shield, Insulating 3-81
157510	Modification Kit 3-86	157899	Arm, Contact 3-50, 3-51	160586	Contact Assembly 3-81
157511	Modification Kit 3-69	157948	Keylever Assembly 3-57, 3-79	160587	Contact Assembly 3-81
157513	Modification Kit 3-57	157972	Bellcrank 3-28	160588	Bracket, Contact 3-81
157514	Modification Kit 3-77	157973	Extension 3-77	160589	Contact Assembly 3-81
157530	Modification Kit 3-57, 3-79	157975	Cable Assembly 3-52	160650	Cable Assembly 3-52
157531	Modification Kit 3-79	157979	Link, Toggle 3-38	160751	Pallet, Type 3-44
157589	Contact Assembly 3-81	157990	Bracket 3-8	160755	Box Assembly, Type 3-45
157600	through	157991	Stud 3-8	160843	Spring 3-22
157634	Pallet, Type 3-42	158304	Plate, Guide 3-78	160844	Box Assembly, Type 3-44
157635	Pallet, Type 3-44	158314	Bracket 3-2, 3-94	169886	Modification Kit 3-87
157636	through	158316	Follower, Bellcrank 3-2, 3-94	160937	Bail 3-87
157641	Pallet, Type 3-44, 3-45	158316	Plate, Nut 3-2, 3-94	160938	Arm, Slide 3-87
157642	Pallet, Type 3-42, 3-45			160939	Post, Spring 3-87
157643	Pallet, Type 3-44			160940	Post 3-87
				160999	Box Assembly, Type 3-45

## NUMERICAL INDEX - SECTION 3 (Continued)

Part Number	Description and Page Number	Part Number	Description and Page Number	Part Number	Description and Page Number
161081	Box Assembly, Type 3-45	163159	Bracket w/Hub 3-93	164348	Box Assembly, Type 3-45
161082	Cable Assembly 3-52	163162	Cable Assembly 3-52	164498	Box Assembly, Type 3-44
161137	Cam, Eccentric 3-92	163183	Modification Kit 3-89	164572	Plate, Mounting 3-91
161138	Retainer 3-92	163184	Bracket, Magnet 3-89	164573	Rod 3-91, 3-95
161140	Modification Kit 3-58	163185	Armature 3-89	164574	Bracket, Right 3-91
161141	Modification Kit 3-58	163250	Pin 3-89	164575	Bracket, Left 3-91
161250	Gear, Spur (88T) 3-58	163251	Bracket, Mounting 3-89	164576	Rod 3-91
161260	Disk 3-58	163252	Stud 3-89	164577	Bracket 3-91, 3-95
161261	Disk 3-58	163254	Modification Kit 3-89	164586	Box Assembly, Type 3-44
161269	Arm, Slide 3-88	163271	Lever, Function 3-49	164594	Cable Assembly 3-52
161270	Arm, Slide 3-88	163292	Modification Kit 3-87	164600	Holder, Paper 3-91
161271	Link 3-88	163293	Cam, Eccentric 3-87	164611	Guard 3-5
161272	Bracket w/Stud 3-88	163294	Ratchet 3-87	164958	Screw (4-40 x 1/2 Hex) 3-89
161273	Bracket w/Stud 3-88	163295	Box Assembly, Type 3-45	164960	Insulator 3-89
161278	Lever 3-88	163308	through	170164	Box Assembly, Type 3-44
161279	Spring 3-88	163314	Pallet, Type 3-45	172181	Modification Kit 3-92
161280	Modification Kit 3-88	163459	Gear, Helical (66T) 3-19	172190	Bracket 3-92
161342	Lever 3-33	163503	Gear, Helical (26T) 3-19	172226	Rod, Copy Holder 3-92
161346	Washer, Felt 3-37, 3-38	163535	Modification Kit 3-90	172500	through
161347	Washer, Felt 3-10, 3-12, 3-28, 3-29, 3-30, 3-72	163590	Gear, Helical (60T) 3-19	172557	Switch Assembly 3-50
161362	through	163776	Stop 3-5	172591	Spring, Contact Arm 3-50
161365	Box Assembly, Type 3-45	163778	Stud 3-5	172593	through
161366	through	163783	Lever w/Stud 3-5	172597	Plate 3-50
161377	Pallet, Type 3-45	163786	Bracket 3-5	172599	Plate 3-50
161491	Pawl, Feed 3-77, 3-92	163787	Bail, Detent 3-5	172600	through
161492	Pawl, Feed 3-77, 3-92	163788	Bracket, Guide 3-5	172607	Switch Assembly 3-50
161649	Lever, Function 4-49	163790	Frame, Right 3-5	172618	Plate 3-50
161767	Modification Kit 3-58	163791	Frame, Left 3-5	172619	Plate 3-50
161769	Box Assembly, Type 3-44	163943	Lever w/Pin Function 3-49	172723	Box Assembly, Type 3-44
162056	Box Assembly, Type 3-45	163944	Lever, Function 3-49	173141	Lever, Function 3-49
162058	Box Assembly, Type 3-45	163947	Modification Kit 3-90	173450	Cable 3-35
162059	Lever, Function 3-49	163948	Gear, Spur (28T) 3-5, 3-90	174086	Box Assembly, Type 3-44
162298	Slide 3-48	163949	Bushing 3-5, 3-90	174482	Lever 3-49
162484	Lever, Function 3-49	163951	Gear w/Shaft, Spur (28T) 3-5, 3-90	176642	Clip 3-47
162539	Box Assembly, Type 3-44	163954	Handwheel 3-5, 3-90	176704	Spring 3-87
162573	Retainer 3-19	163955	Arm w/Hub and Stud 3-90	179235	Bracket, Right 3-95
162605	Box Assembly 3-44	163956	Lever 3-5, 3-90	179236	Bracket, Left 3-95
162636	through	163957	Lever 3-5, 3-90	179237	Clamp, Right 3-95
162640	Bar, Function 3-53, 3-54	163958	Washer, Flat 3-5, 3-90	179238	Clamp, Left 3-95
163146	Modification Kit 3-93	163959	Spring 3-90	179239	Bracket, Right 3-95
163147	Contact Assembly 3-93	163960	Bushing 3-5, 3-90	179240	Bracket, Left 3-95
163148	Shaft 3-93	163968	Cable Assembly 3-52	179241	Rack, Copy Display 3-95
163150	Collar 3-93	164218	Box Assembly, Type 3-45	179301	Plate 3-95
163151	Spring, Contact 3-93	164219	Arm 3-5	179309	Finger, Left Paper 3-95
163152	Cam w/Stud 3-93	164220	Spring 3-5	179310	Finger, Right Paper 3-95
163153	Cam, Trip 3-93	164270	Modification Kit 3-91	179366	Shaft 3-95
163157	Cam, Drive 3-93	164311	Lever, Function 3-49	179368	Roller 3-95
163158	Bracket w/Hub 3-93	164313	Bracket 3-41	179369	Modification Kit 3-95
		164314	Plate 3-26	179377	Post 3-95
		164316	Plate 3-26		
		164317	Modification Kit 3-58		

# **SECTION 4**

## **MOTOR UNIT**



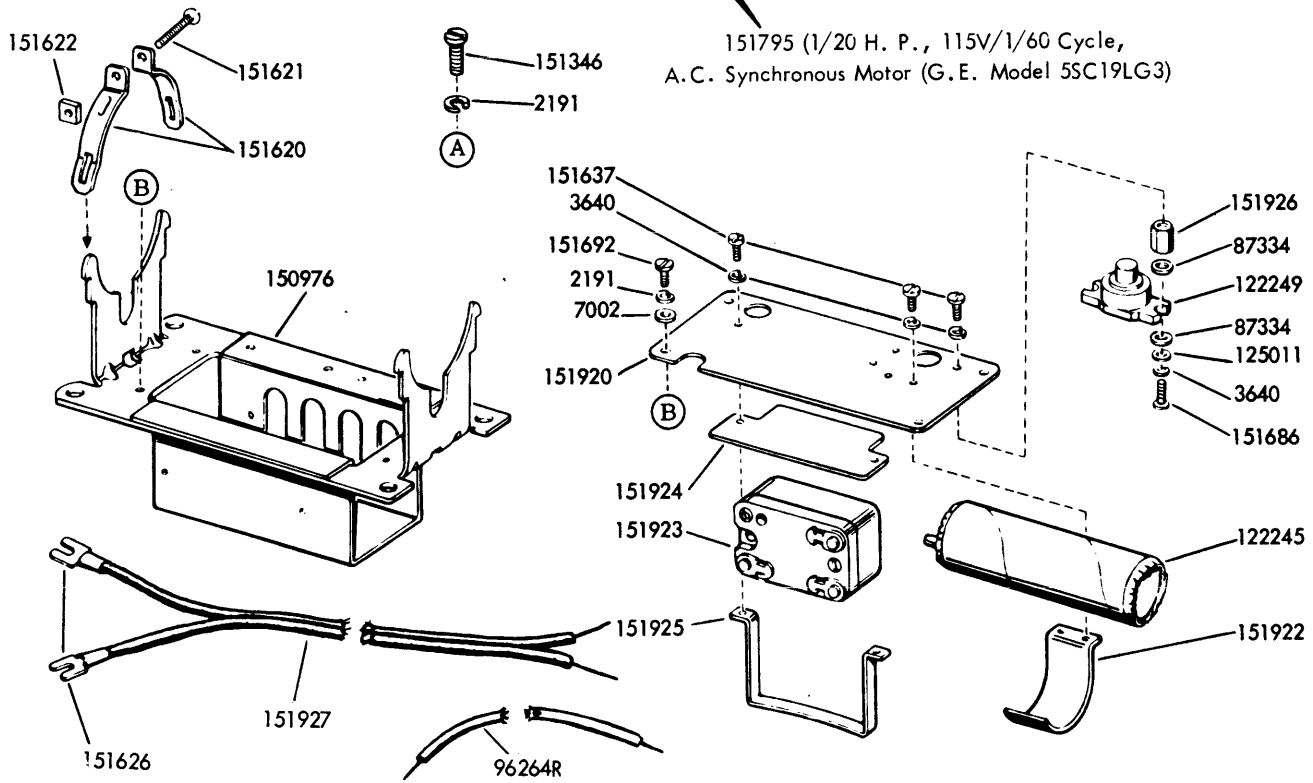
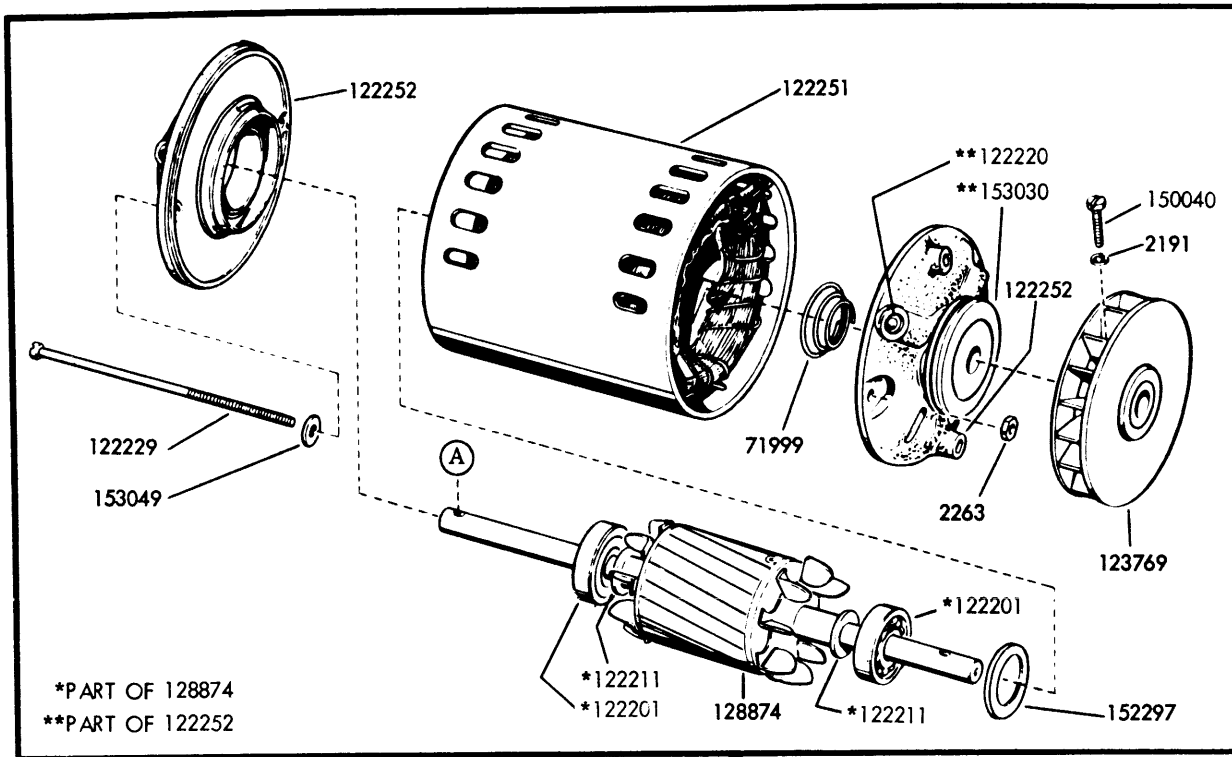
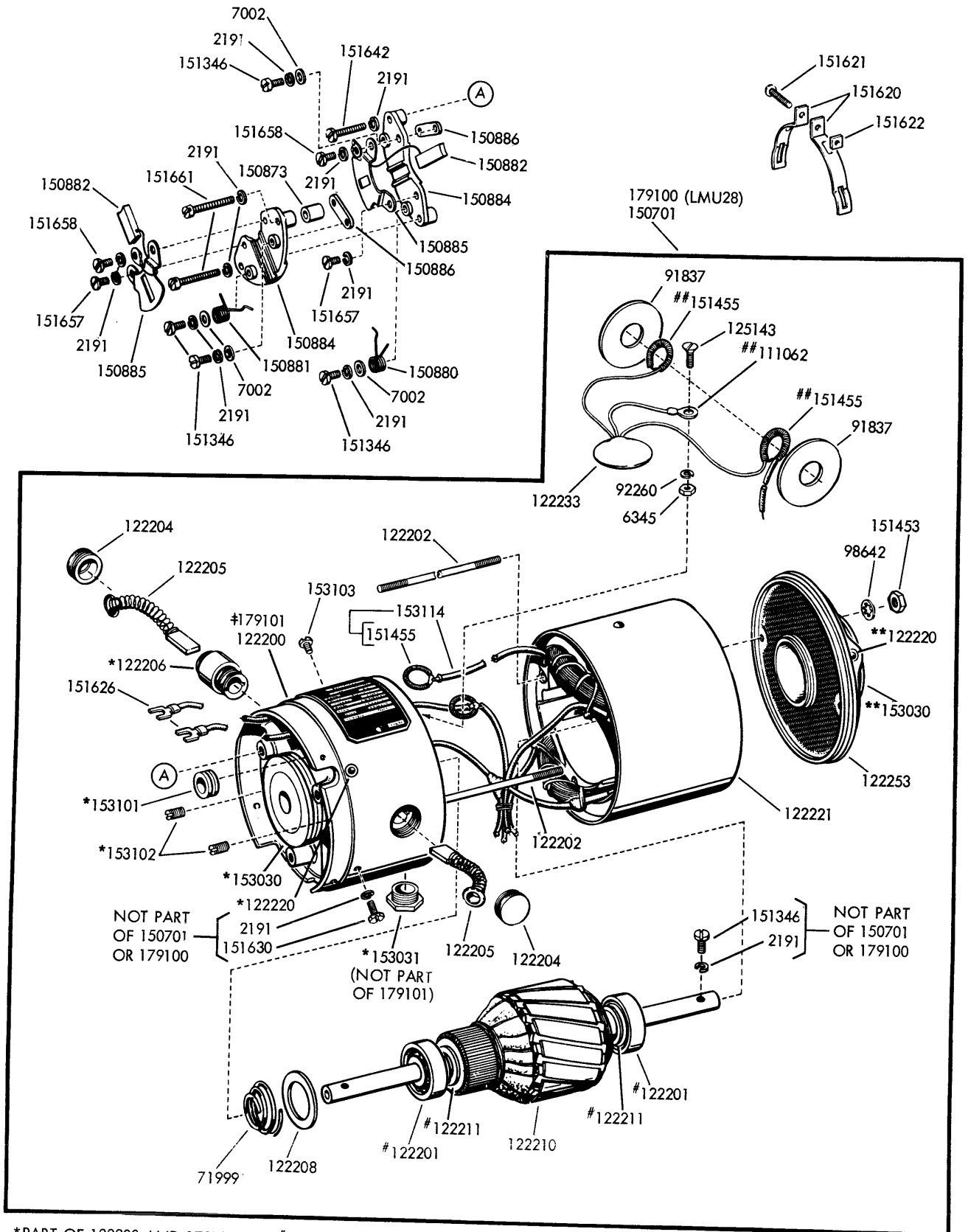


FIGURE 4-1. LMU3 SYNCHRONOUS MOTOR UNIT



\*PART OF 122200 AND 179101  
\*\*PART OF 122253

#PART OF 122210  
##PART OF 122233

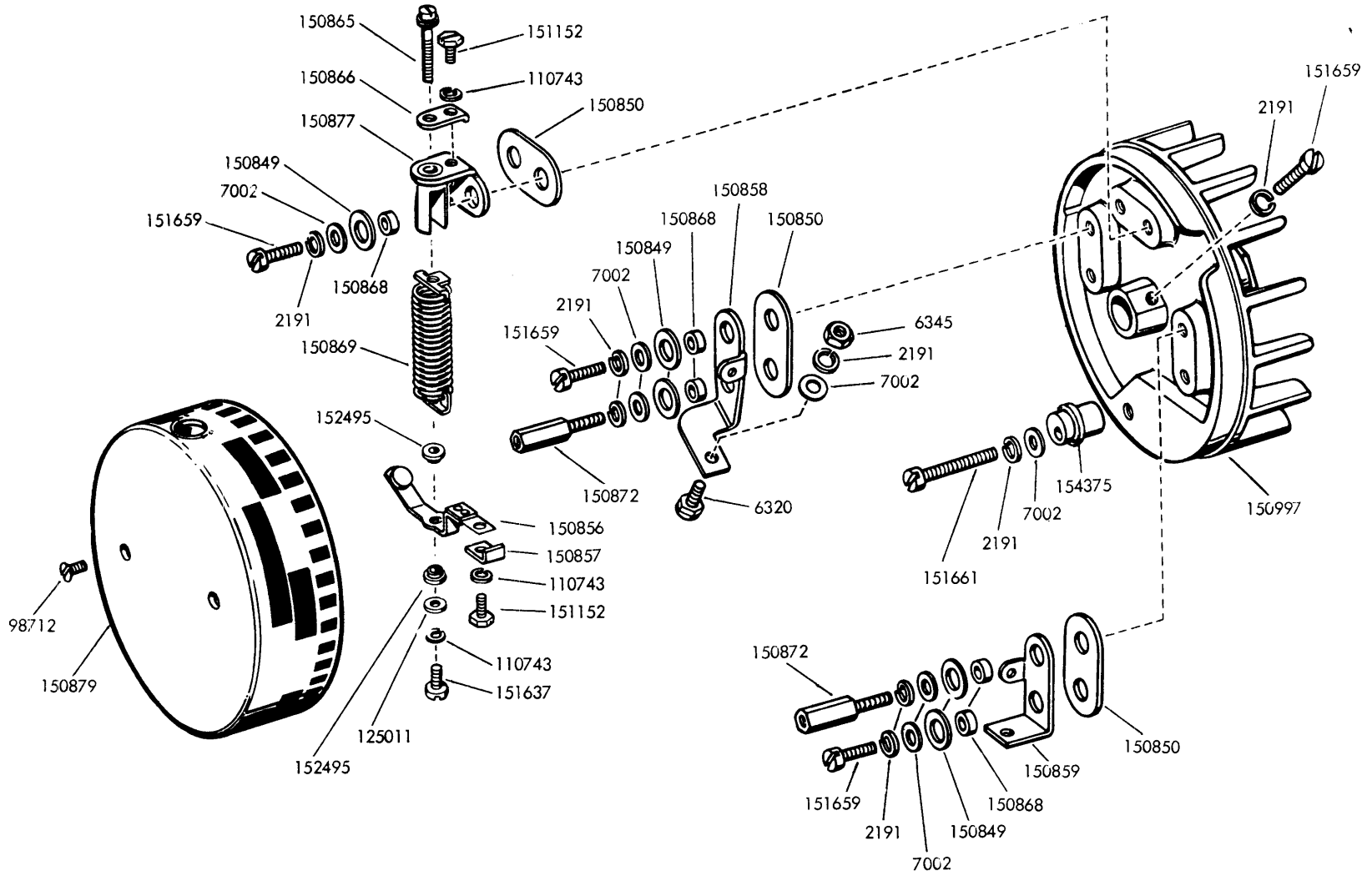
≠PART OF 179100

PART OF LMU4, 6, 10 & 28

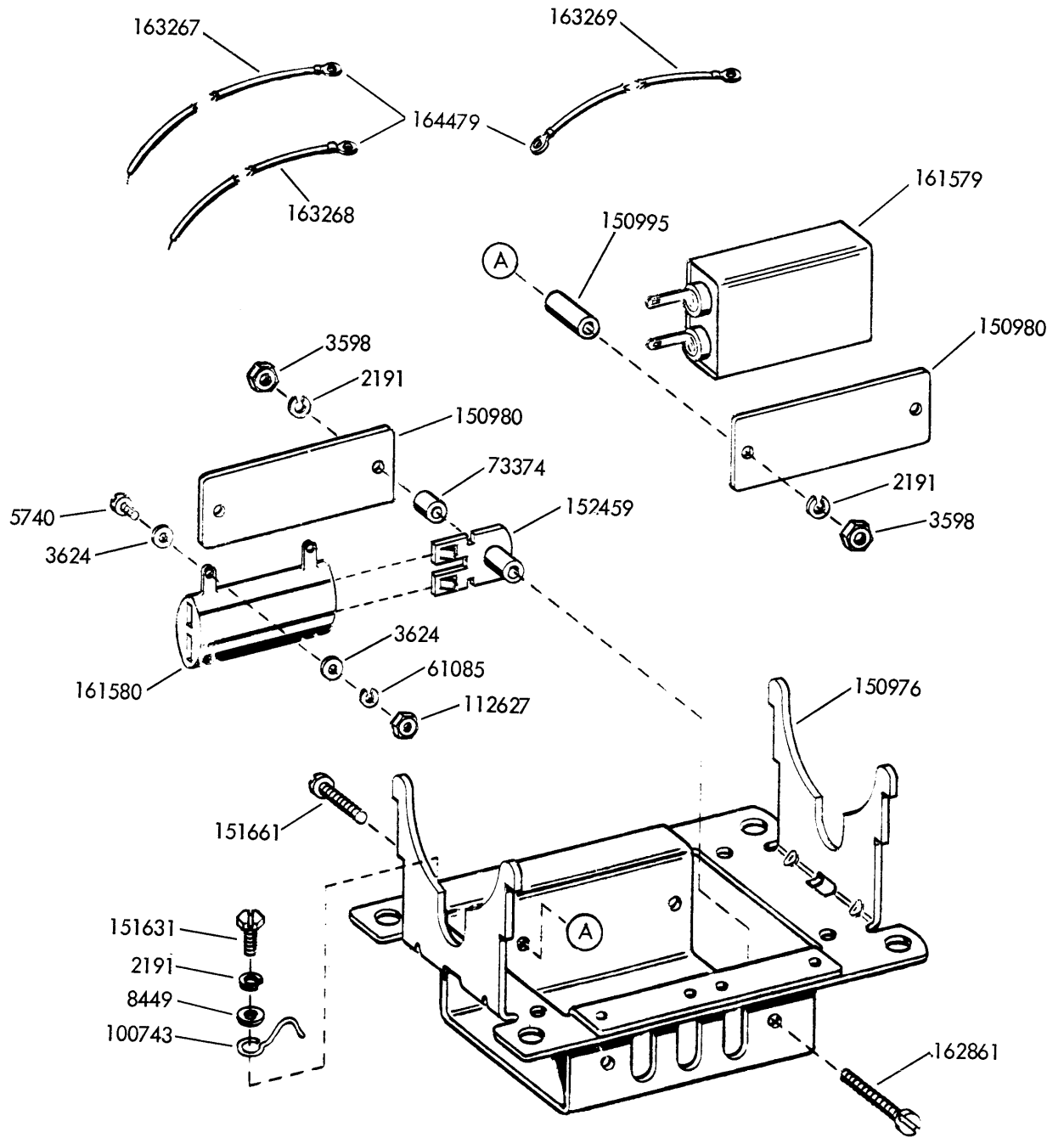
FIGURE 4-2. SERIES MOTOR

FIGURE 4-3. 150845 GOVERNOR ASSEMBLY

PART OF LMU4, 6 & 28



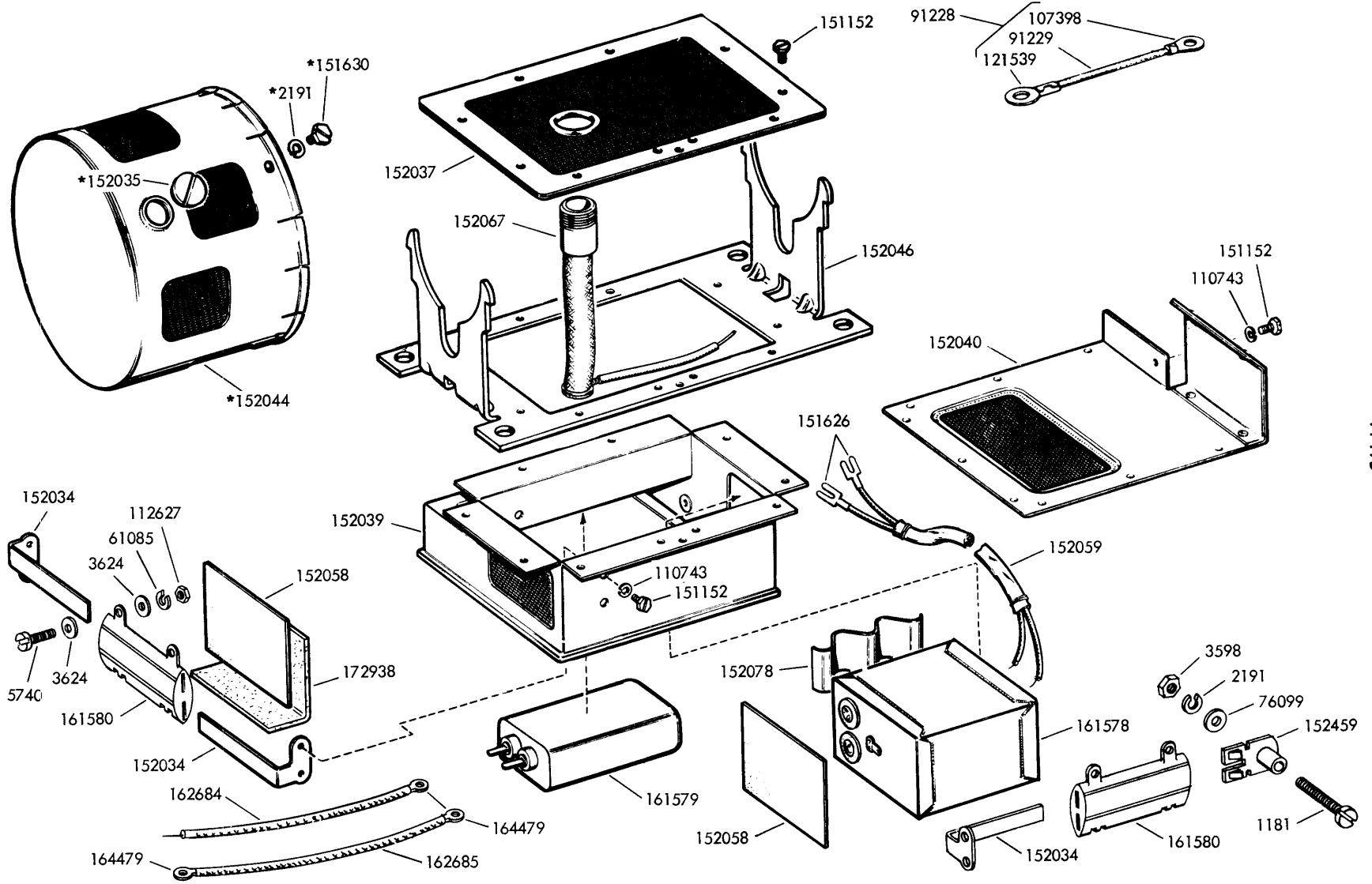
1149B



PART OF LMU6

FIGURE 4-4. SERIES MOTOR MOUNTING PARTS

FIGURE 4-5. SERIES MOTOR MOUNTING PARTS WITH RF SUPPRESSION



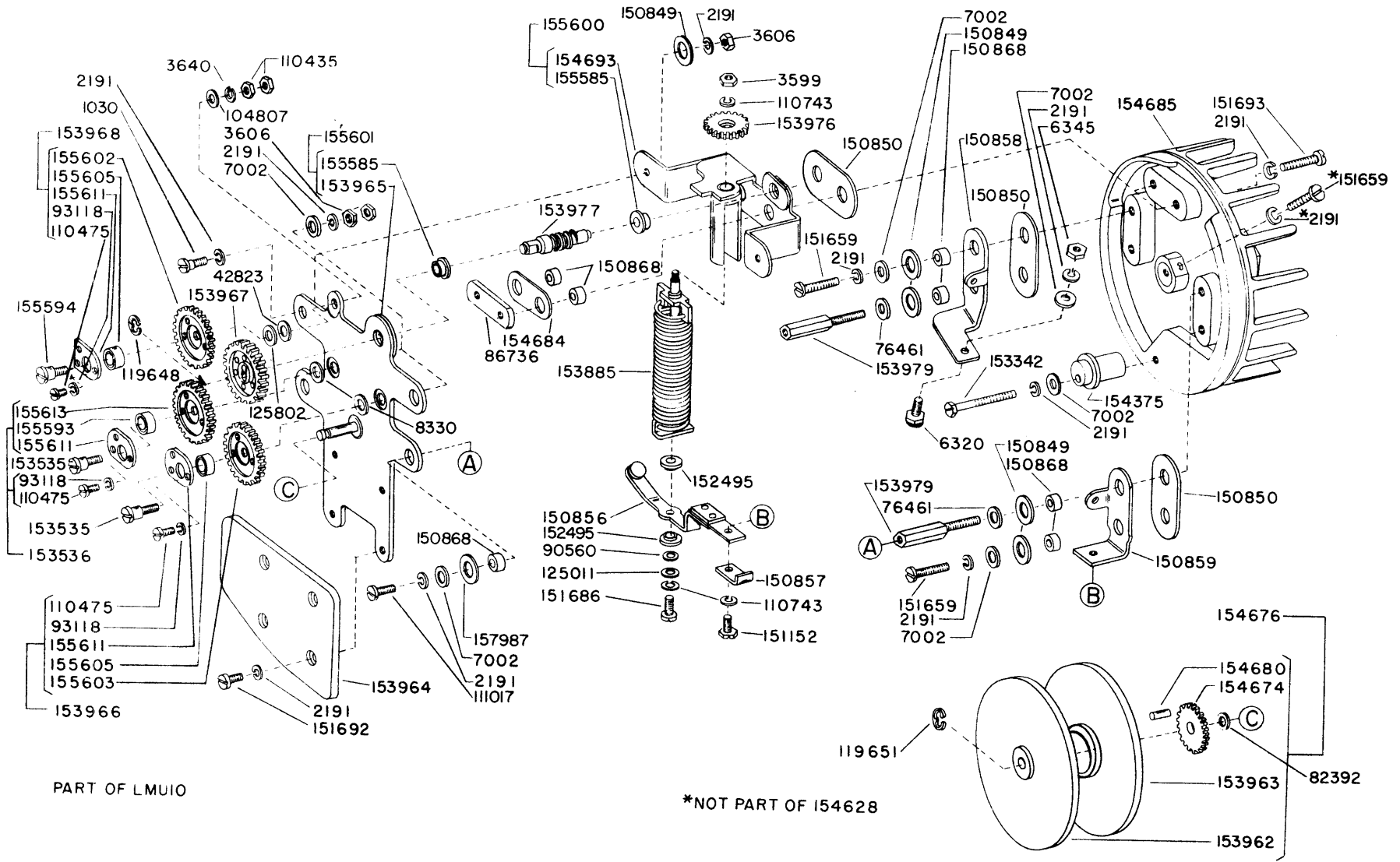
11498

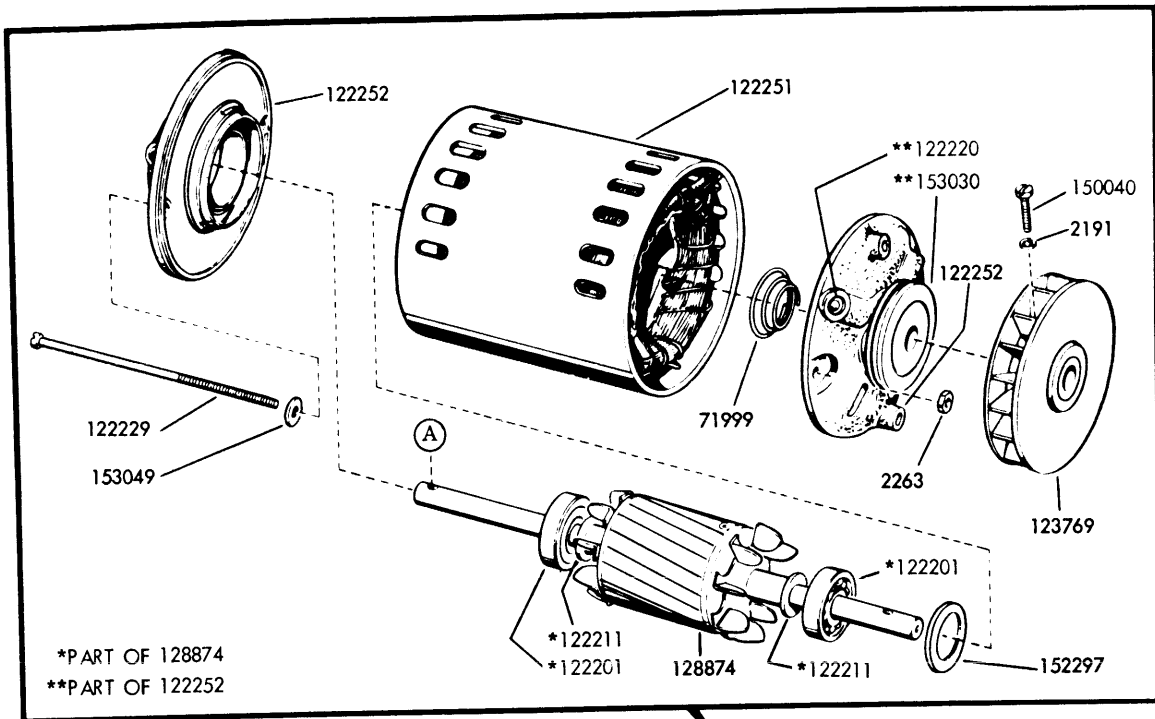
\*PECULIAR TO LMU4. SEE FIGURE 1-30 FOR LMU10 PARTS

PART OF LMU4 & 10

CHANGE II

FIGURE 4-6. 154628 GOVERNOR ASSEMBLY





151795 (1/20 H. P., 115V/1/60 Cycle,  
A.C. Synchronous Motor (G.E. Model 5SC19LG3)

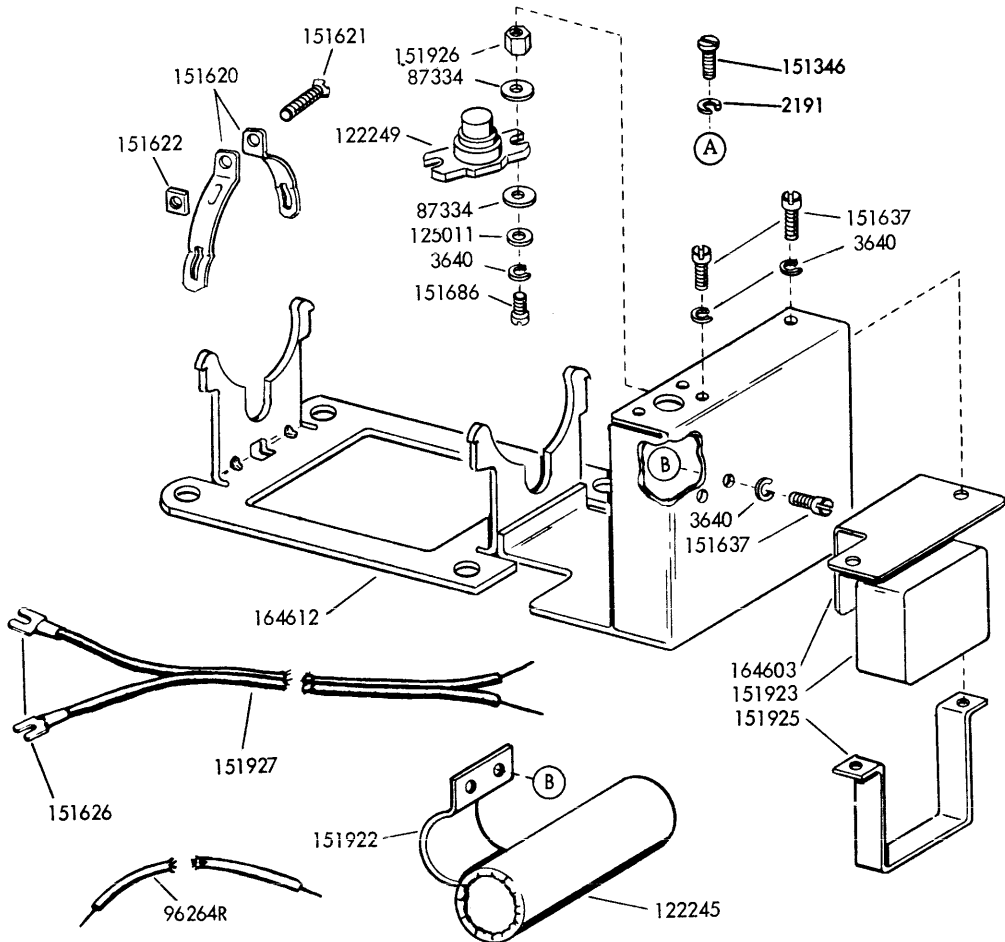
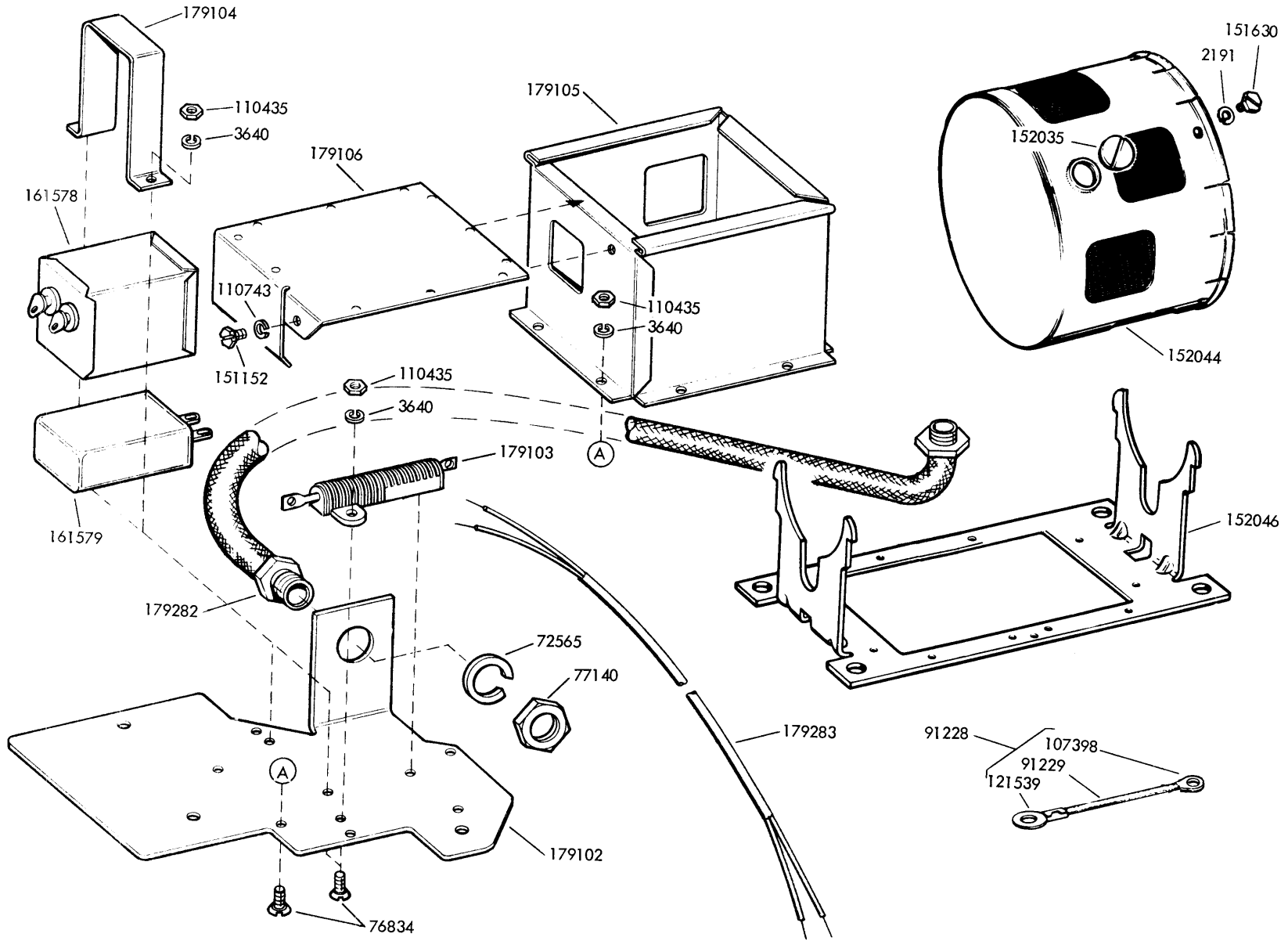


FIGURE 4-7. LMU21 SYNCHRONOUS MOTOR UNIT

CHANGE II

FIGURE 4-8. SERIES MOTOR MOUNTING PARTS

PART OF 1MU28



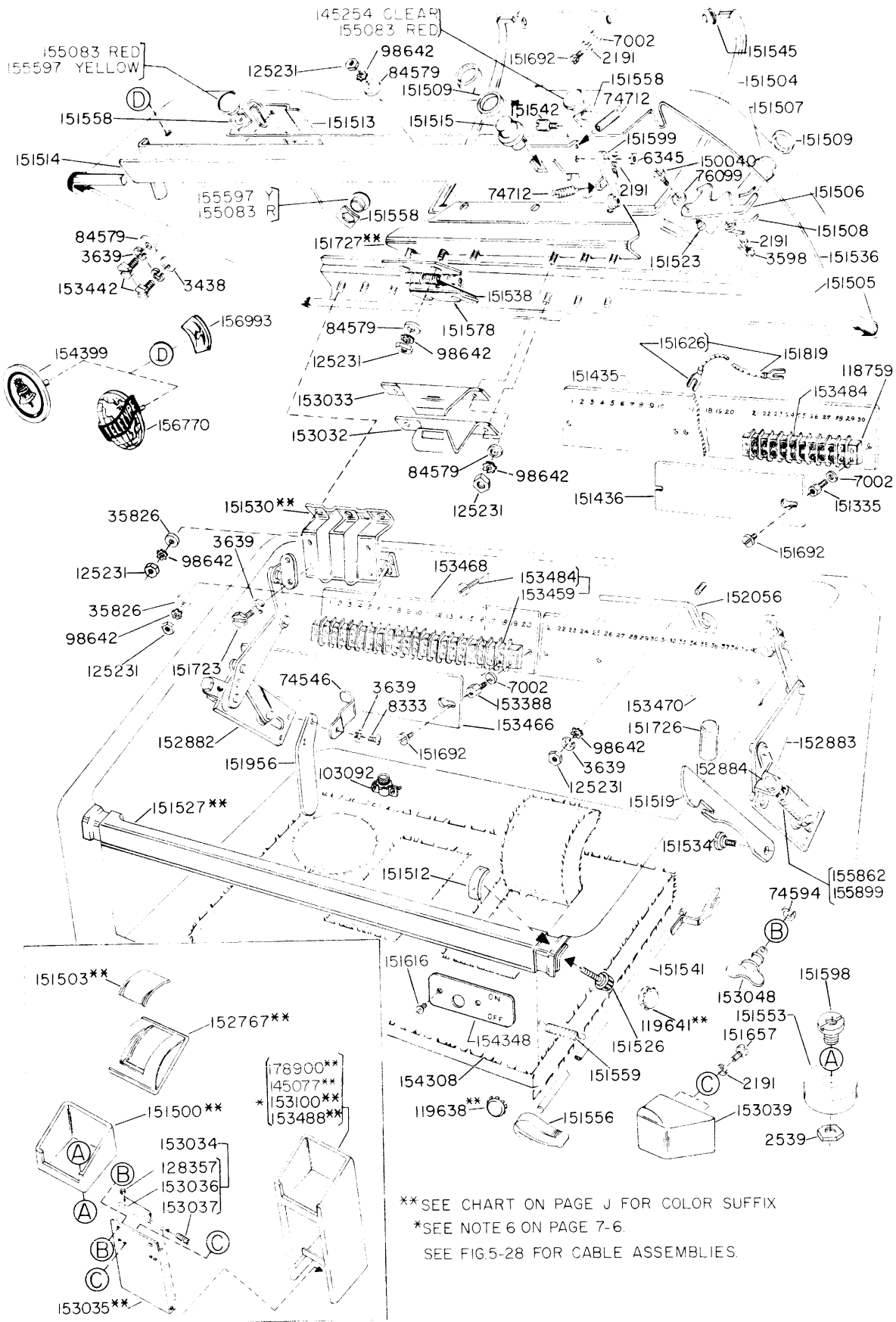
1149B



## NUMERICAL INDEX - SECTION 4

Part Number	Description and Page Number	Part Number	Description and Page Number	Part Number	Description and Page Number
1030	Screw, Shoulder (6-40) 4-7	125011	Washer, Flat (Sev.)	152067	Nipple 4-6
1181	Screw (6-40 x 11/16 Fil) 4-6	125143	Screw (6-32 x 5/16 Flat) 4-3	152078	Spring, Separator 4-6
2191	Washer, Lock (Sev.)	125802	Washer, Flat 4-7	152297	Washer, Flat 4-2,4-8
2263	Nut (8-32 Hex) 4-2,4-8	128874	Rotor 4-2,4-8	152459	Bracket 4-5,4-6
3598	Nut (6-40 Hex) (Sev.)	150040	Screw (6-40 x 5/8 Fil) 4-2,4-8	152495	Bushing 4-4,4-7
3599	Nut (4-40 Hex) (Sev.)	150701	Motor, Series 4-3	153030	Mount, Vibration 4-2,4-3,4-8
3606	Nut (6-40 Hex) 4-7	150849	Washer, Insulating 4-4,4-7	153031	Bushing 4-3
3624	Washer, Flat 4-5	150850	Plate 4-4,4-7	153049	Washer, Fiber 4-2,4-8
3640	Washer, Lock 4-2,4-7,4-8,4-9	150856	Contact 4-4,4-7	153101	Grommet 4-3
5740	Screw (2-56 x 1/4 Fil) 4-5,4-6	150857	Clamp 4-4,4-7	153102	Screw, Set (8-32) 4-3
6320	Screw, Contact 4-4,4-7	150858	Bracket 4-4,4-7	153103	Screw, Self Tapping (4-40) 4-3
6345	Nut (6-32 Hex) 4-3,4-4,4-7	150859	Bracket 4-4,4-7	153342	Screw (6-40 x 15/16 Hex) 4-7
7002	Washer, Flat (Sev.)	150865	Screw (4-40 x 27/32 Fil) 4-4	153535	Screw, Shoulder (6-40) 4-7
8330	Washer, Flat 4-7	150866	Clamp 4-4	153536	Gear Assembly 4-7
8449	Collar 4-5	150868	Bushing 4-4,4-7	153962	Disk 4-7
42823	Washer, Flat 4-7	150869	Spring 4-4	153963	Disk 4-7
61085	Washer, Lock 4-5,4-6	150872	Stud 4-4	153964	Counterweight 4-7
71999	Spring 4-2,4-3,4-8	150873	Collar 4-3	153965	Bracket 4-7
72565	Washer, Lock 4-9	150877	Bracket 4-4	153966	Gear Assembly 4-7
73374	Spacer 4-5	150879	Cover 4-4	153967	Gear (28T) 4-7
76099	Washer, Flat 4-6	150880	Spring 4-3	153968	Gear Assembly 4-7
76461	Washer, Flat 4-7	150881	Spring 4-3	153976	Gear (32T) 4-7
76834	Screw (4-40 x 3/4 Fil) 4-9	150882	Brush 4-3	153977	Worm 4-7
77140	Nut (9/16-32 Hex) 4-9	150884	Mounting, Brush 4-3	153979	Post 4-7
82392	Shim 4-7	150885	Plate, Brush 4-3	154375	Backstop Assembly 4-4,4-7
86736	Plate, Clamping 4-7	150886	Plate, Clamp 4-3	154628	Governor Assembly 4-7
87334	Washer, Insulating 4-2,4-8	150976	Bracket 4-2,4-5	154674	Gear (20T) 4-7
90560	Washer, Flat 4-7	150980	Plate 4-5	154676	Disk Assembly 4-7
91228	Strap 4-6,4-9	150995	Bushing 4-5	154680	Bearing, Roller 4-7
91229	Wire, Braided 4-6,4-9	150997	Fan 4-4	154684	Insulator 4-7
91837	Washer, Fiber 4-3	151152	Screw (4-40 x 3/16 Hex) 4-4,4-6,4-7,4-9	154685	Fan 4-7
92260	Washer, Lock 4-3	151346	Screw (6-40 x 3/8 Fil) 4-2,4-3,4-8	154693	Bracket 4-7
93118	Washer, Lock 4-7	151453	Nut (10-32 Hex) 4-3	155585	Bearing, Ball 4-7
96264R	Strap 4-2,4-8	151455	Spring 4-3	155593	Bearing Ball 4-7
98462	Washer, Lock 4-3	151620	Strap, Mounting 4-2,4-3,4-8	155594	Screw, Shoulder 4-7
98712	Screw (4-40 x 7/32 Flat) 4-4	151621	Screw (6-32 x 3/4 Rd) 4-2,4-3,4-8	155600	Bracket, Assembly 4-7
100743	Clamp, Cable 4-5	151622	Nut (6-32 Sq) 4-2,4-3,4-8	155601	Plate Assembly 4-7
104807	Washer, Flat 4-7	151626	Terminal (Sev.)	155602	Gear, Idler 4-7
107398	Terminal 4-6,4-9	151630	Screw (6-40 x 1/4 Hex) 4-3,4-6,4-9	155603	Gear, Idler 4-7
110435	Nut (4-40 Hex) 4-7,4-9	151631	Screw (6-40 x 5/16 Fil) 4-5	155605	Bearing, Ball 4-7
110475	Screw (2-64 x 3/32 Spl.) 4-7	151637	Screw (4-40 x 1/4 Fil) 4-2,4-4,4-8	155611	Ring, Bearing 4-7
110743	Washer, Lock (Sev.)	151642	Screw (6-40 x 3/4 Fil) 4-3	155613	Gear, Idler 4-7
111017	Screw (6-40 x 5/16 Fil) 4-7	151657	Screw (6-40 x 1/4 Fil) 4-3	157987	Washer, Insulating 4-7
111062	Terminal 4-3	151658	Screw (6-40 x 5/16 Fil) 4-3	161578	Suppressor, Electric Noise 4-6,4-9
112627	Nut (2-56 Hex) 4-5,4-6	151659	Screw (6-40 x 1/2 Fil) 4-4,4-7	161579	Capacitor, Fixed 4-5,4-6,4-9
119648	Ring, Retaining (Sev.)	151661	Screw (6-40 x 1" Fil) 4-3,4-4,4-5	161580	Resistor 4-5,4-6
119651	Ring, Retaining (Sev.)	151686	Screw (4-40 x 3/8 Fil) 4-2,4-7	162684	Wire Assembly 4-6
121539	Terminal 4-6,4-9	151692	Screw (6-40 x 3/16 Fil) 4-2,4-7	162685	Wire Assembly 4-6
122200	Shield Assembly, End 4-3	151693	Screw (6-40 x 9/16 Fil) 4-7	162861	Screw (6-40 x 1-7/16 Fil) 4-5,4-6
122201	Bearing, Ball 4-3,4-8	151795	Motor, Synchronous 4-2,4-8	163267	Wire Assembly 4-5
122202	Bolt 4-3	151920	Plate, Mounting 4-2	163268	Wire Assembly 4-5
122204	Cap, Brush 4-3	151922	Clamp 4-2,4-8	163269	Wire Assembly 4-5
122205	Brush and Spring 4-3	151923	Relay 4-2,4-8	164479	Terminal 4-5
122206	Holder, Brush 4-3	151924	Insulator 4-2	164603	Insulator 4-8
122208	Washer, Flat 4-3	151925	Clamp 4-2,4-8	164612	Bracket, Mounting 4-8
122210	Armature 4-3	151926	Nut (4-40 Spl.) 4-2,4-8	172938	Insulator 4-6
122211	Washer, Pull 4-2,4-3,4-8	151927	Cable 4-2,4-8	179100	Motor, Series 4-3
122220	Oiler 4-2,4-3,4-8	152034	Bracket 4-6	179101	Shield Assembly, End 4-3
122221	Stator 4-3	152035	Plug 4-6,4-9	179102	Plate 4-9
122229	Bolt (8-32) 4-2,4-8	152037	Cover 4-6	179103	Resistor (250 Ohm) 4-9
122233	Capacitor Assembly 4-3	152039	Container 4-6	179104	Bracket 4-9
122245	Capacitor 4-2,4-8	152040	Lid 4-6	179105	Container 4-9
122249	Switch 4-2,4-8	152044	Cover Assembly 4-6,4-9	179106	Lid 4-9
122251	Stator 4-2,4-8	152046	Bracket 4-6,4-9	179282	Nipple 4-9
122252	Shield Assembly, End 4-2,4-8	152058	Separator 4-6	179283	Cable 4-9
122253	Shield Assembly, End 4-3	152059	Cable Assembly 4-6		
123769	Fan 4-2,4-8				

**SECTION 5**  
**CABINETS AND COVER**



\*\*SEE CHART ON PAGE J FOR COLOR SUFFIX  
\*SEE NOTE 6 ON PAGE 7-6.  
SEE FIG.5-28 FOR CABLE ASSEMBLIES.

FIGURE 5-1. LAC202\*\*,LAC203\*\*,LAC204\*\*,LAC213\*\*,LAC215\*\* AND LAC216\*\* CABINETS

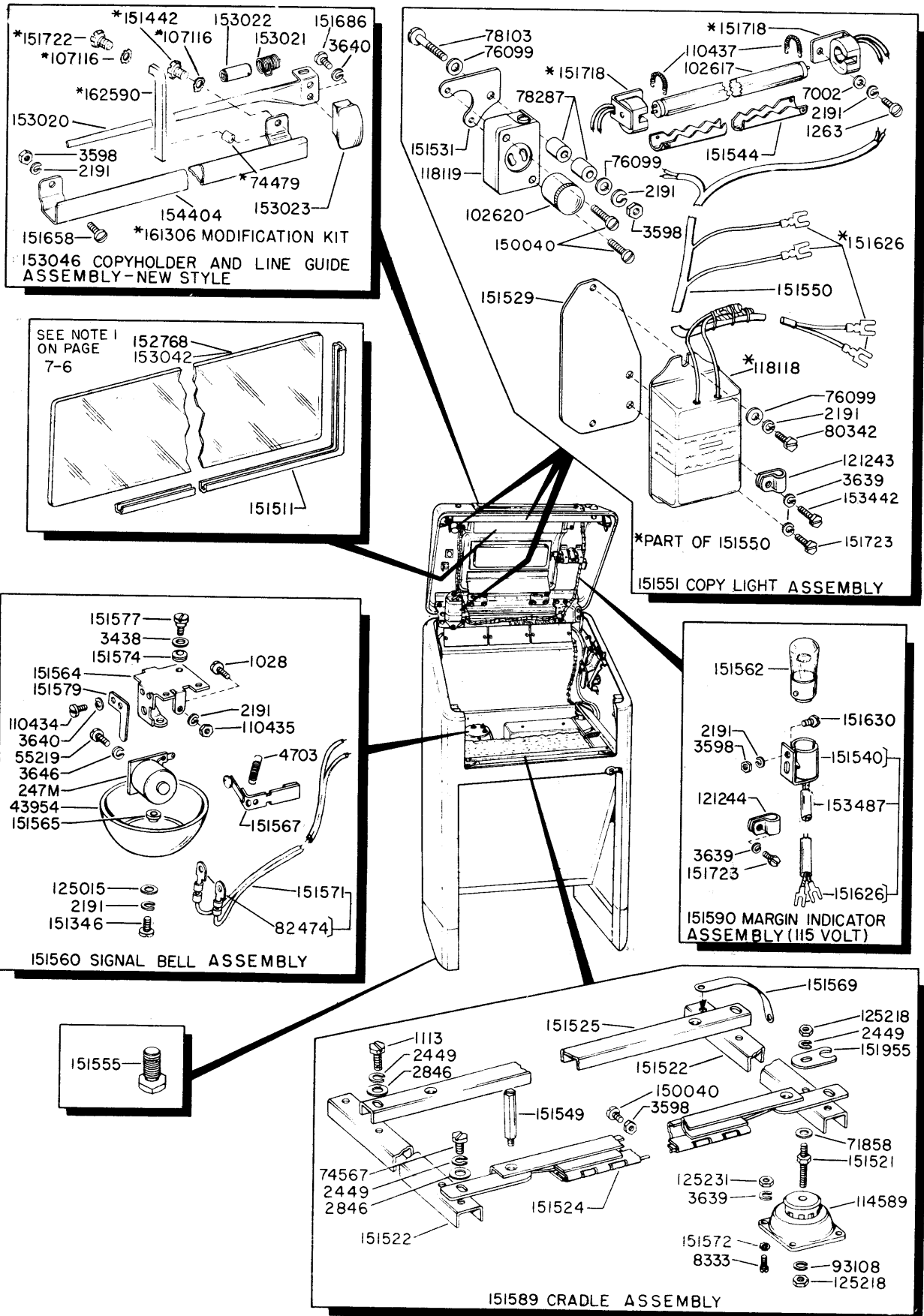


FIGURE 5-2. VARIABLE FEATURES FOR LAC202\*\* CABINET

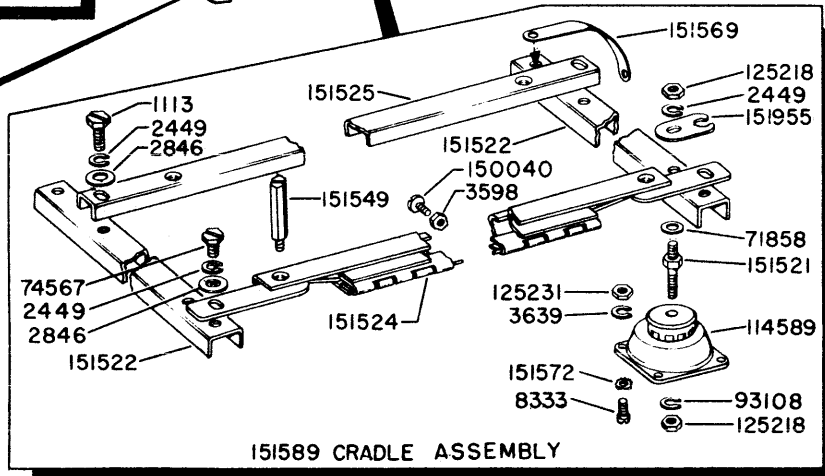
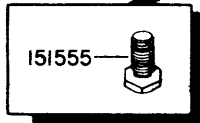
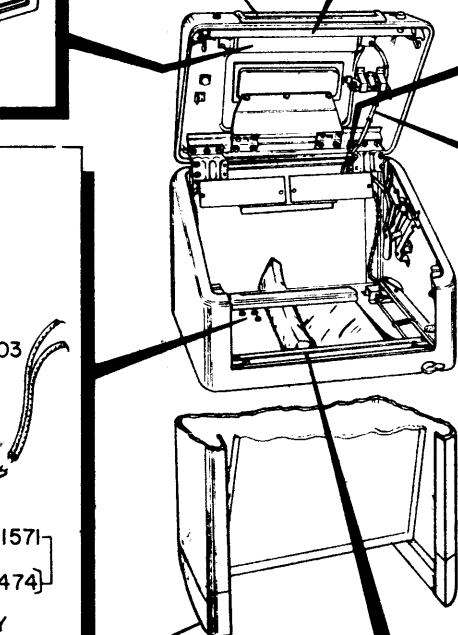
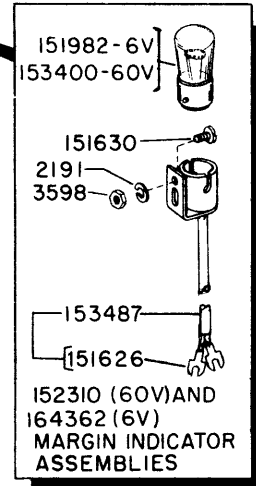
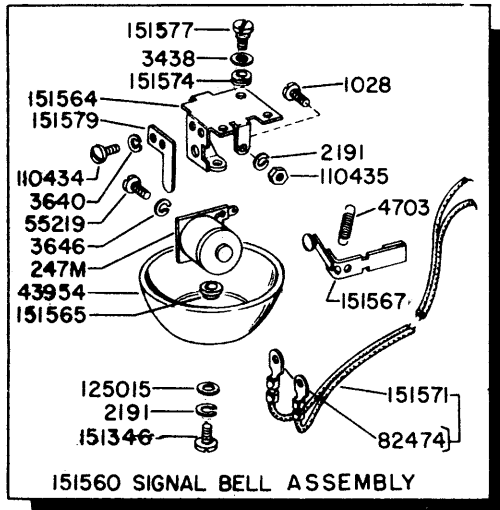
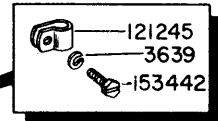
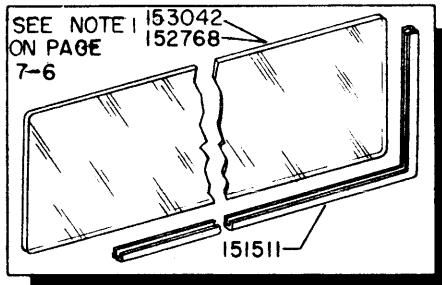
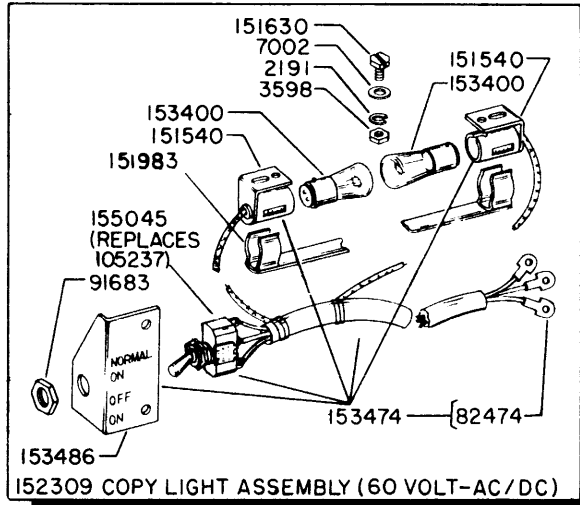
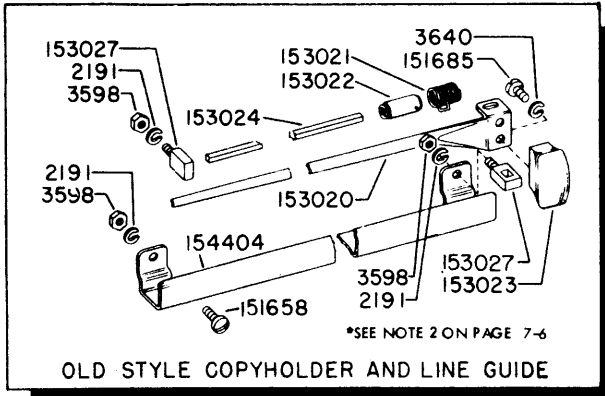
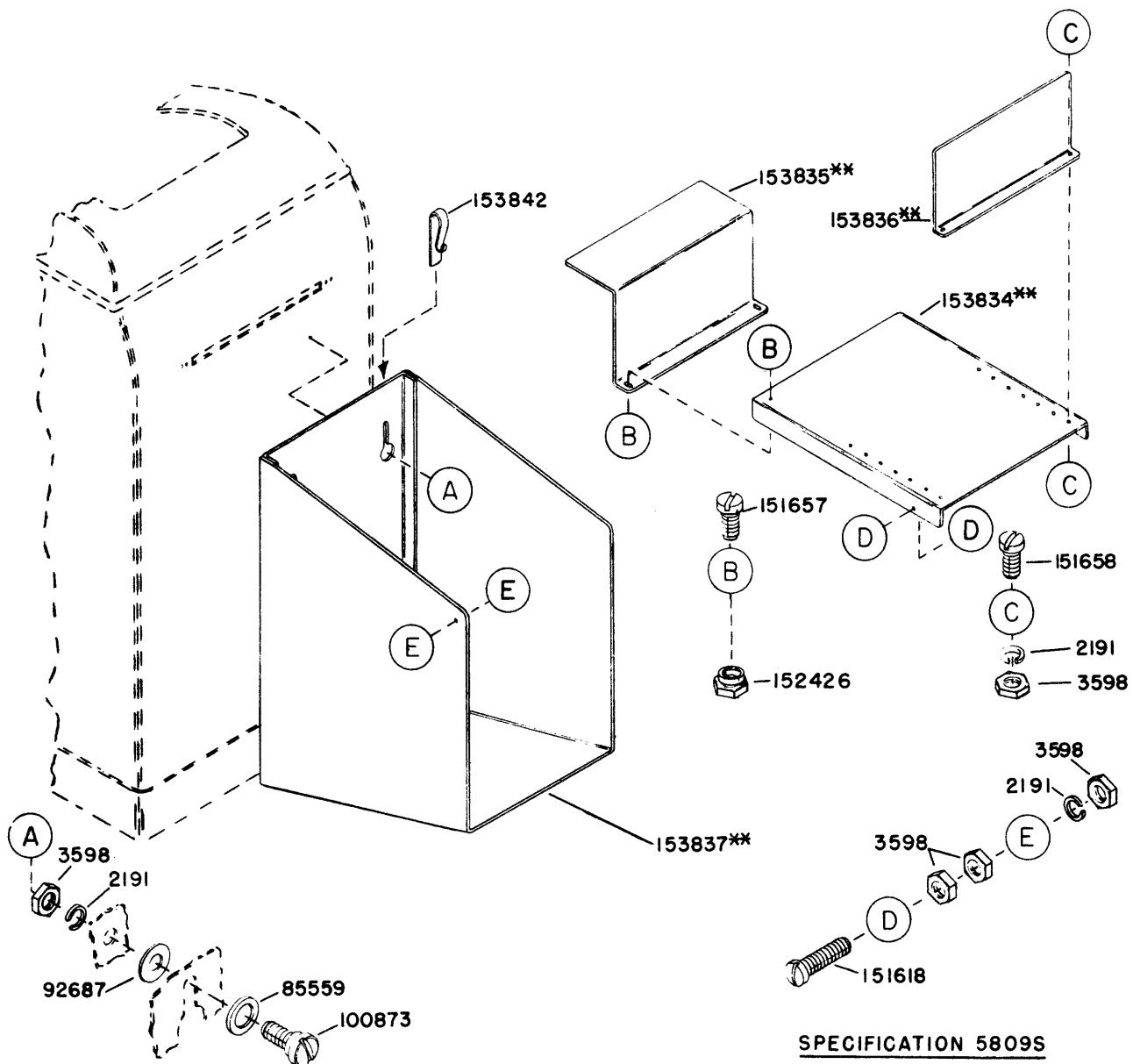


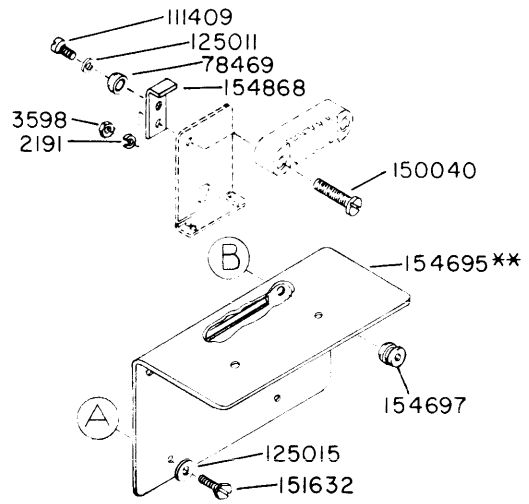
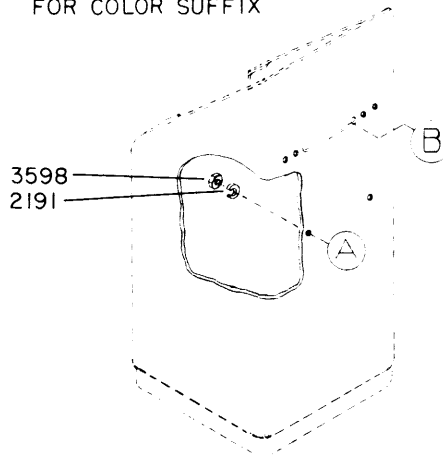
FIGURE 5-3. VARIABLE FEATURES FOR LAC203\*\*, LAC204\*\*, LAÇ213\*\*, LAC215\*\*, LAC216\*\* CABINETS



\*\*SEE CHART ON PAGE J FOR COLOR SUFFIX

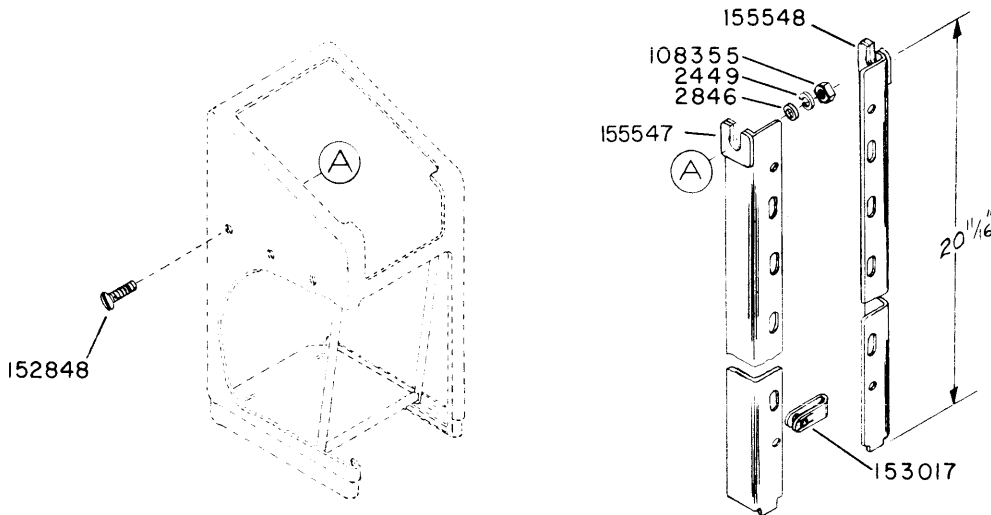
FIGURE 5-4. 152349\*\* MODIFICATION KIT TO PROVIDE PAPER SUPPLY AND ACCUMULATING SHELF

\*\*SEE CHART ON PAGE J  
FOR COLOR SUFFIX



SPECIFICATION 5805S

FIGURE 5-5. 153901\*\* MODIFICATION KIT TO PROVIDE PAPER WINDER MOUNTING BRACKET

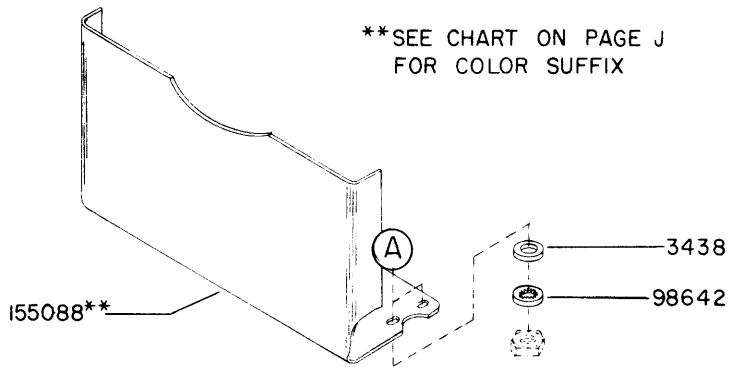
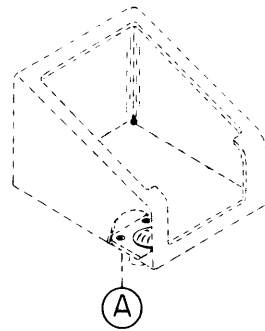


SPECIFICATION 5730S

USED WITH LAC202\*\* AND LAC204\*\*

FIGURE 5-6. 159373 MODIFICATION KIT TO PROVIDE APPARATUS MOUNTING RACK

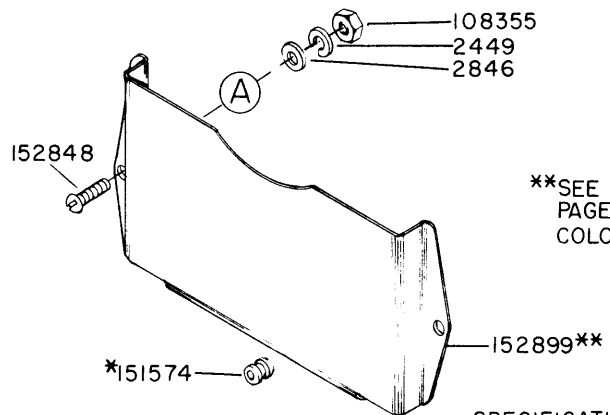
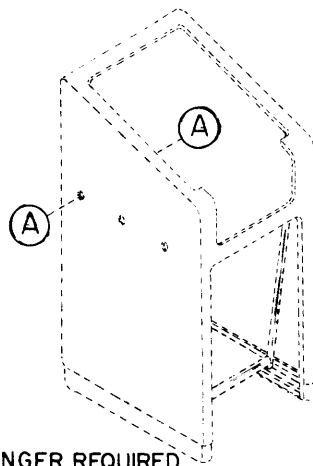
1149B



\*\*SEE CHART ON PAGE J  
FOR COLOR SUFFIX

SPECIFICATION 5729S

FIGURE 5-7. 152300\*\* MODIFICATION KIT TO PROVIDE DIRECTORY HOLDER

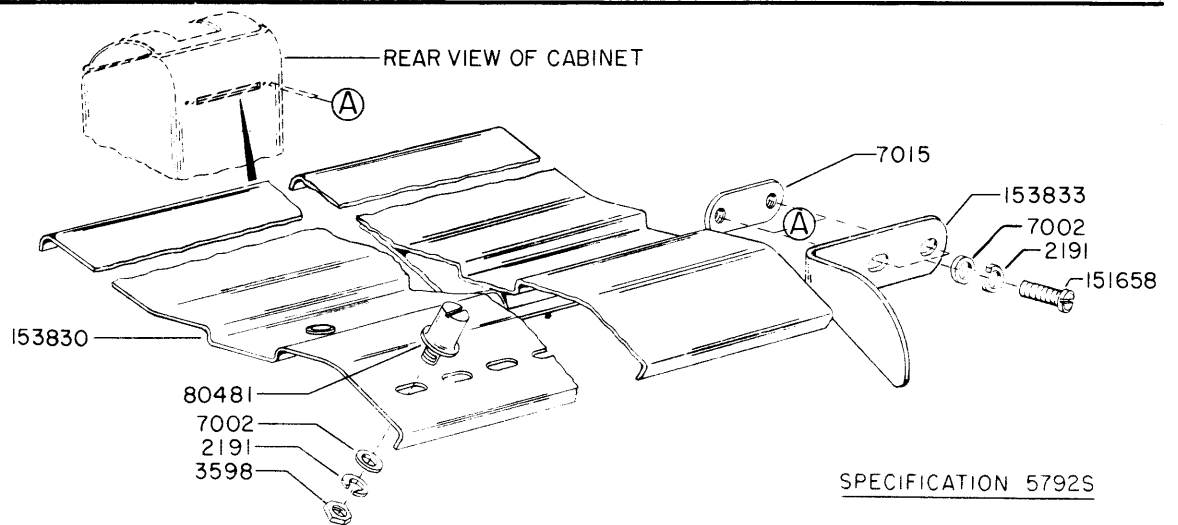


\*\*SEE CHART ON  
PAGE J FOR  
COLOR SUFFIX

SPECIFICATION 5729S

\*NO LONGER REQUIRED

FIGURE 5-8. 152910\*\* MODIFICATION KIT TO PROVIDE DIRECTORY HOLDER

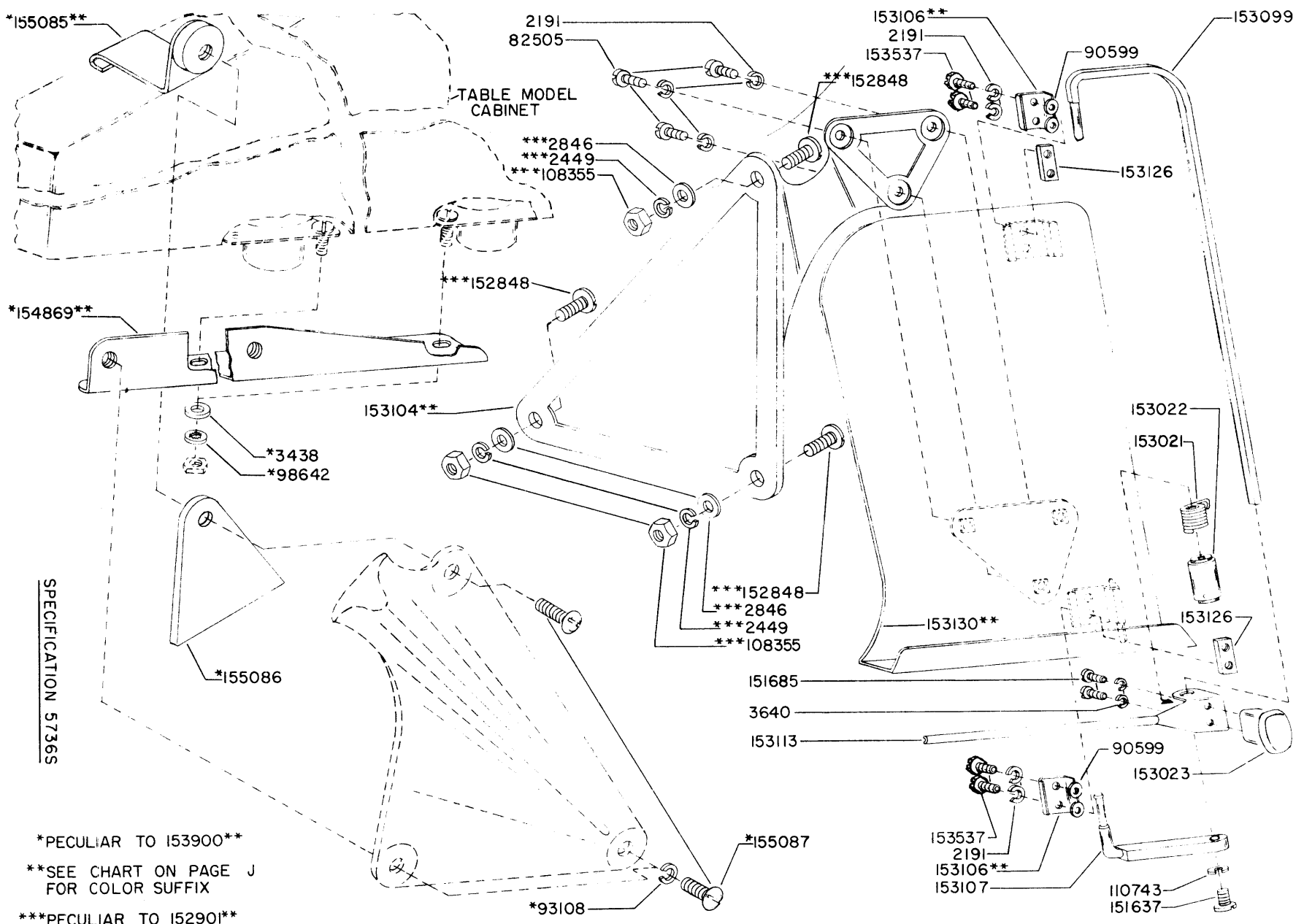


SPECIFICATION 5792S

FIGURE 5-9. 153926 MODIFICATION KIT TO PROVIDE SPROCKET FEED REAR PAPER GUIDE

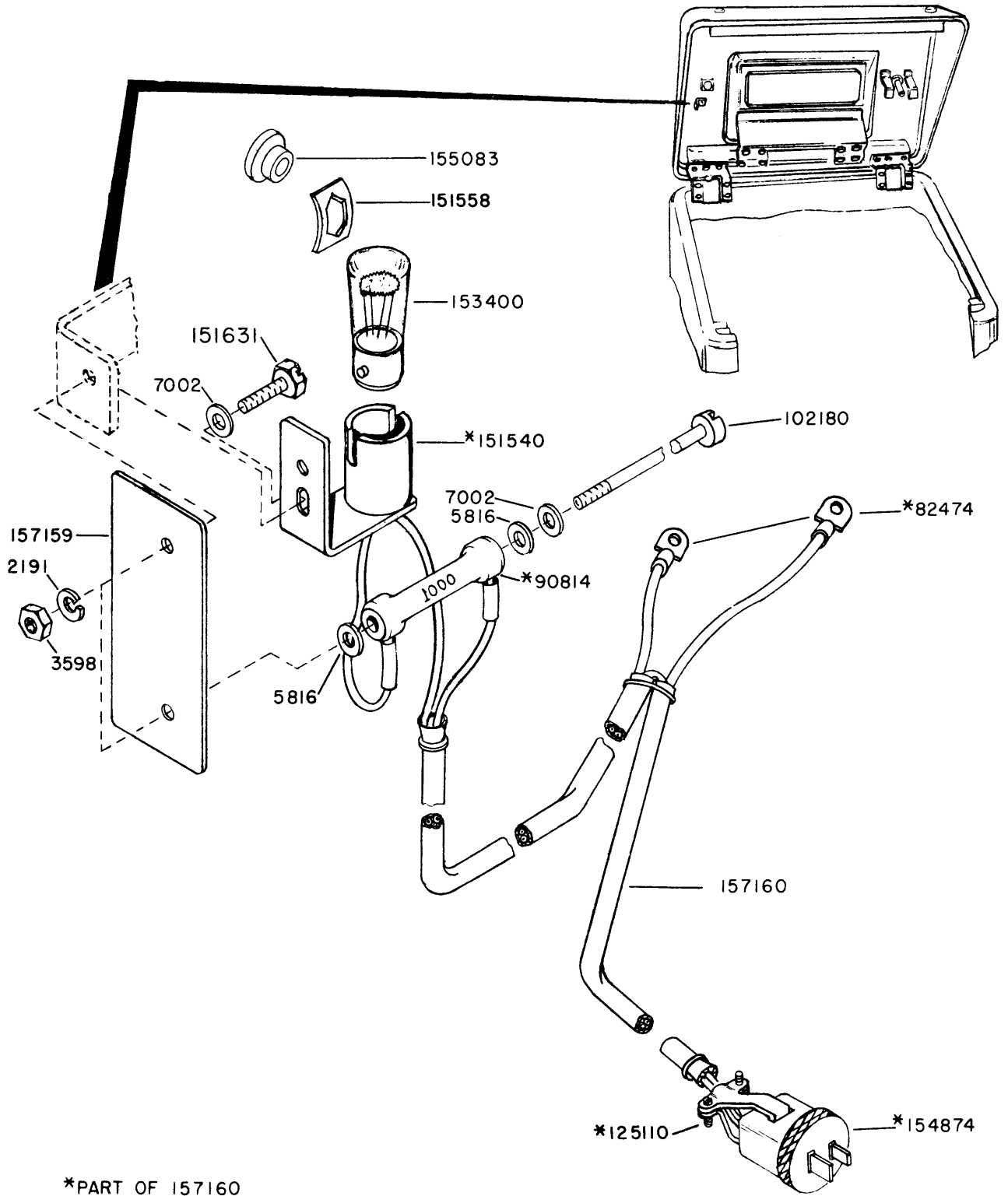


FIGURE 5-10. 152901\*\* AND 153900\*\* MODIFICATION KITS TO PROVIDE OFFSET COPYHOLDERS



SPECIFICATION 5736S

\*PECULIAR TO 153900\*\*  
 \*\*SEE CHART ON PAGE J FOR COLOR SUFFIX  
 \*\*\*PECULIAR TO 152901\*\*



SPECIFICATION 5821S

FIGURE 5-11. 152902 MODIFICATION KIT TO EQUIP A CABINET WITH A BUSY LAMP

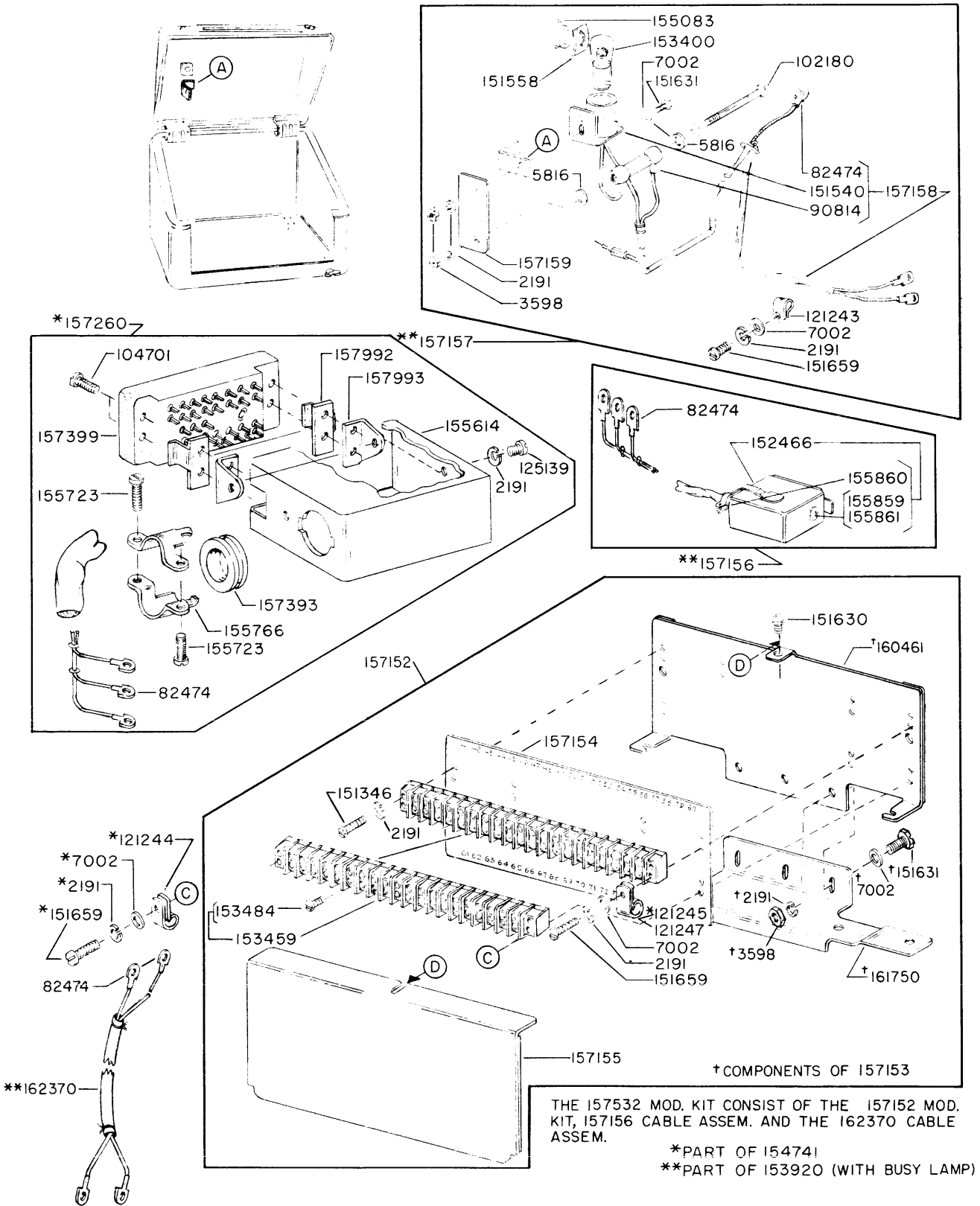


FIGURE 5-12. 153920 AND 154741 MODIFICATION KITS TO ADAPT A CABINET FOR SELECTIVE CALLING

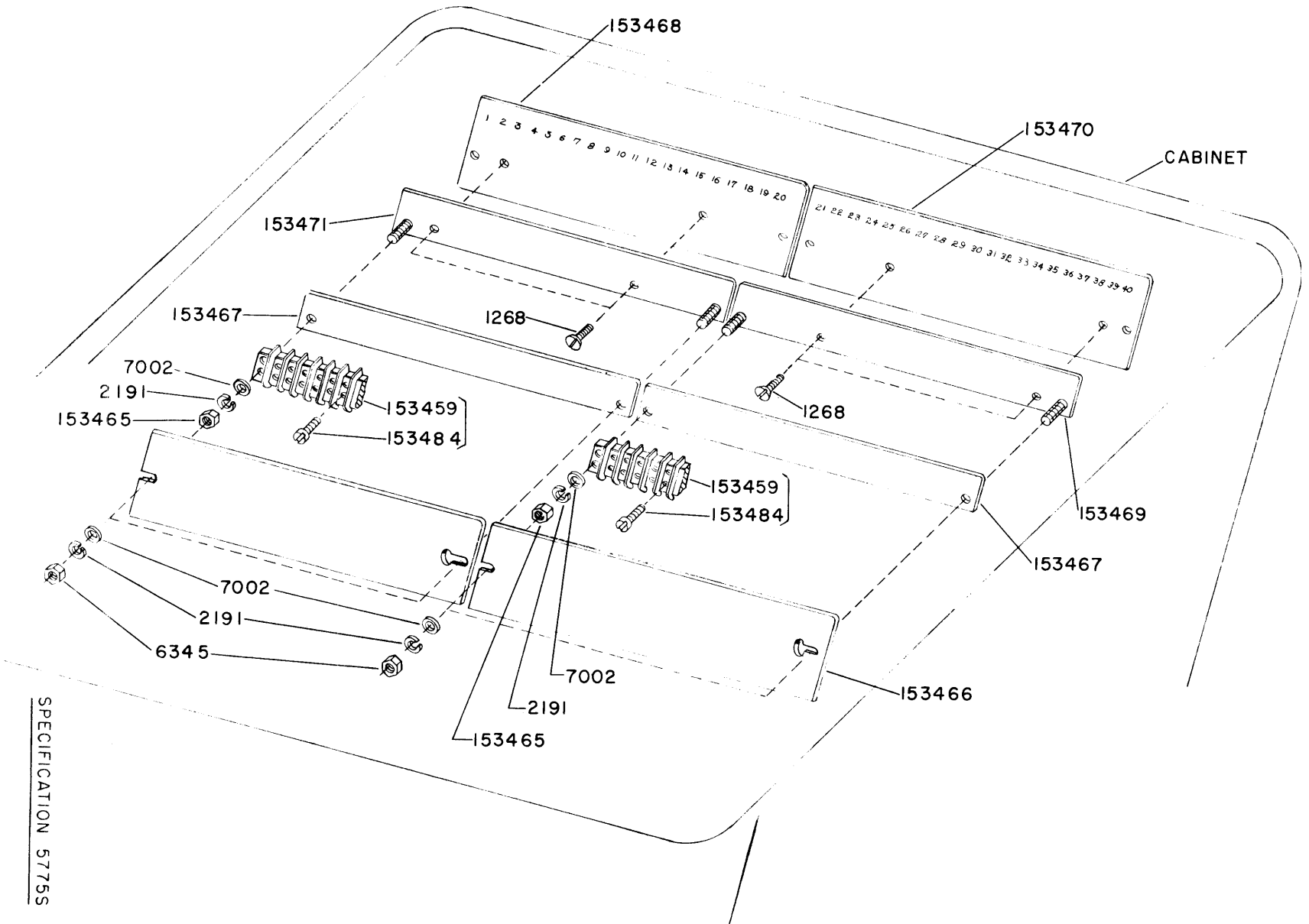
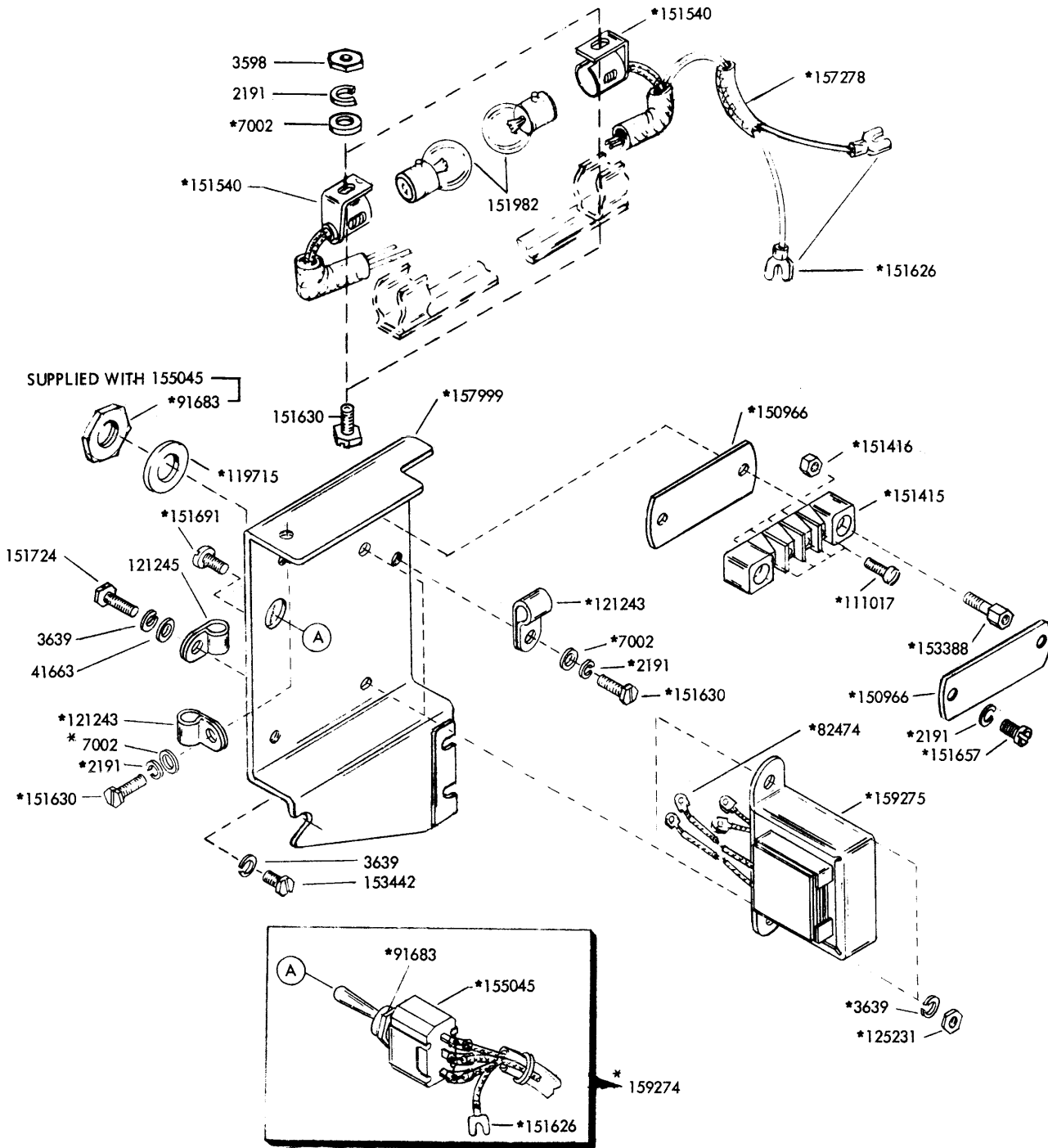


FIGURE 5-13. 152319 MODIFICATION KIT TO PROVIDE ADDITIONAL TERMINAL CONNECTIONS ON CABINET

SPECIFICATION 57755



NOTE:  
 15923 COPYLIGHT ASSEMBLY  
 CONSISTS OF PARTS MARKED  
 WITH AN ASTERISK (\*).

SPECIFICATION 58535

FIGURE 5-14. 15937 MODIFICATION KIT TO PROVIDE 5.5 VOLT A.C. INCANDESCENT COPYLIGHT SYSTEM

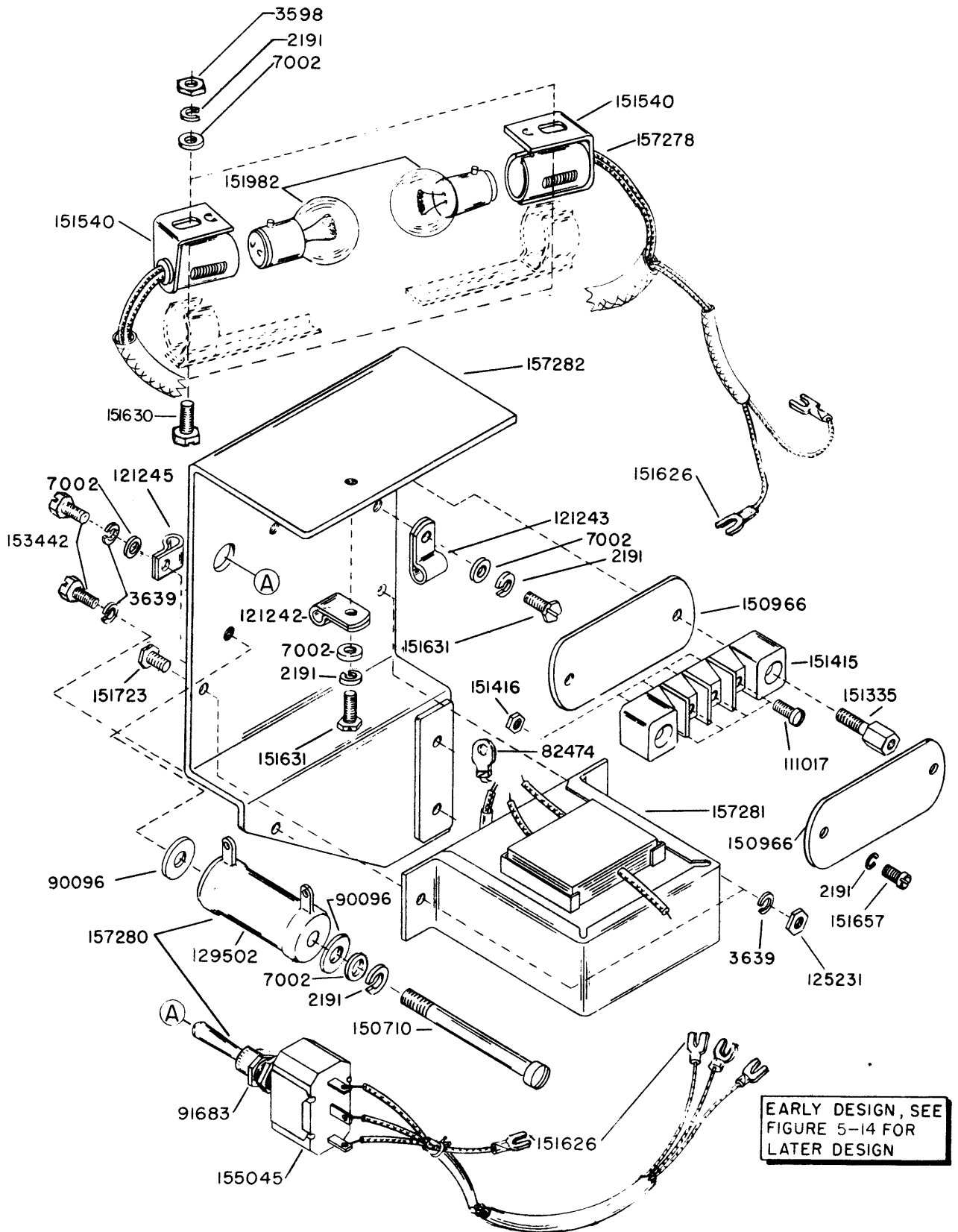


FIGURE 5-15. 6 VOLT A. C. INCANDESCENT COPYLIGHT SYSTEM

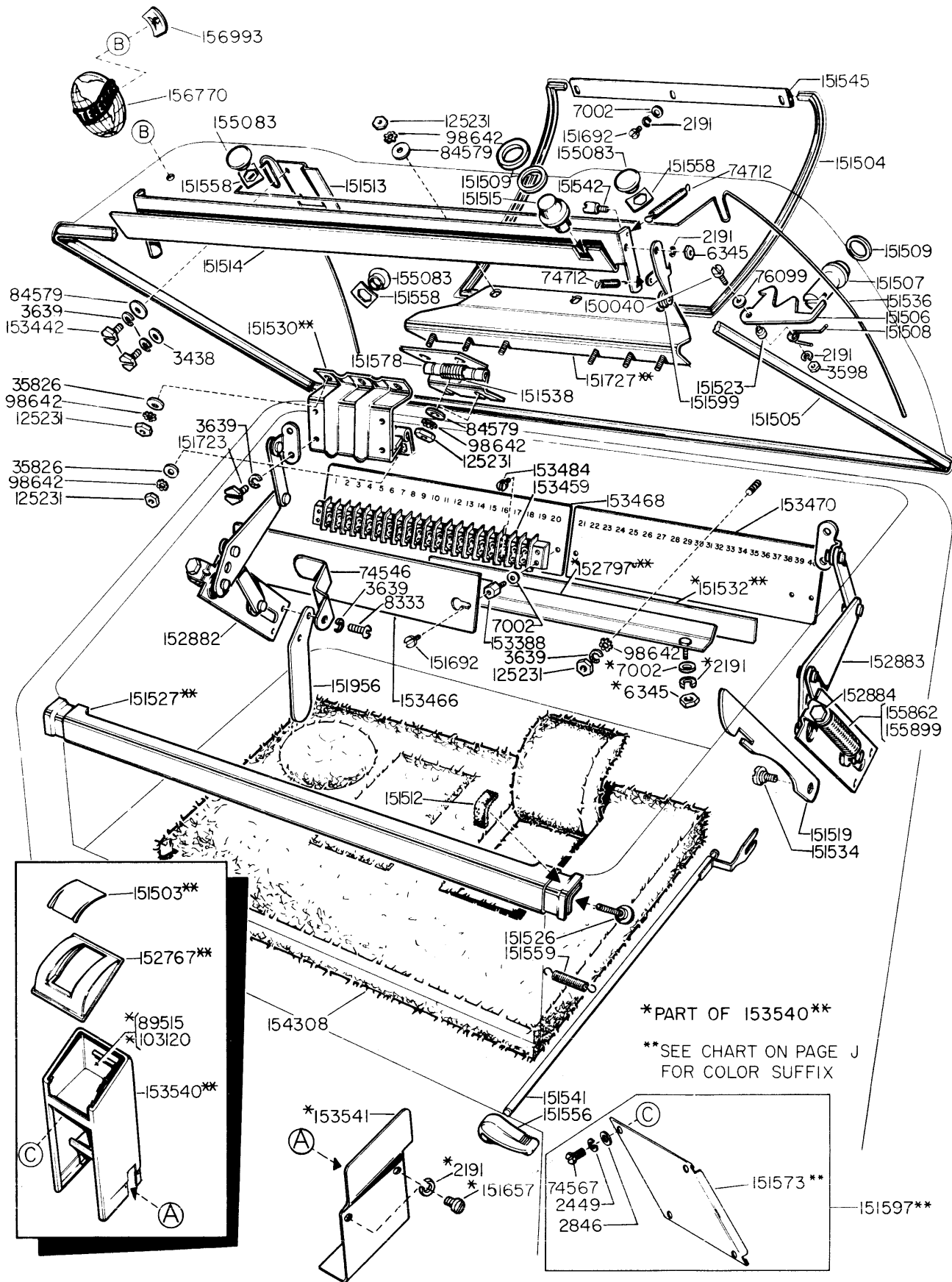


FIGURE 5-16. LAC205\*\* CONSOLE CABINET

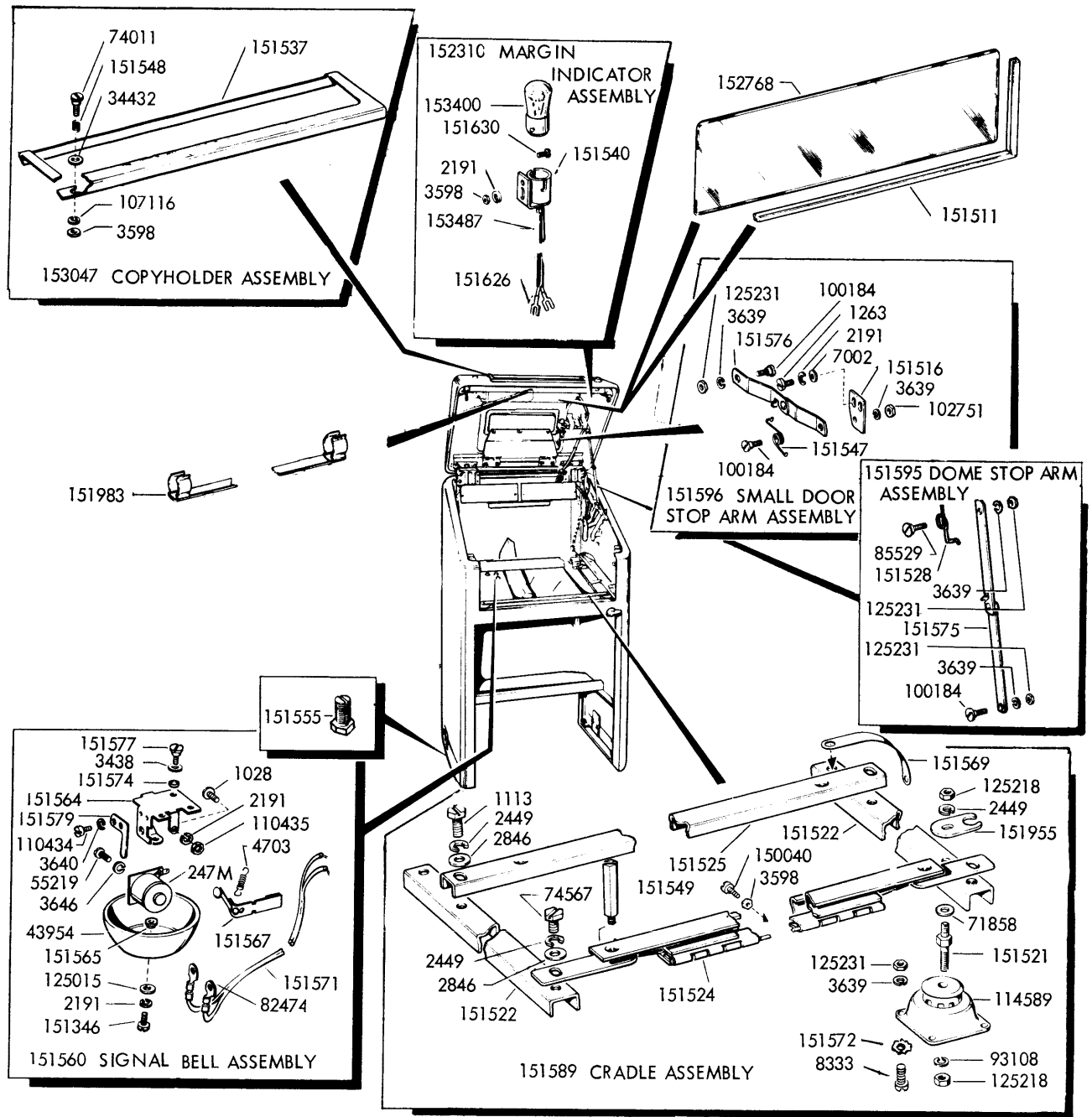
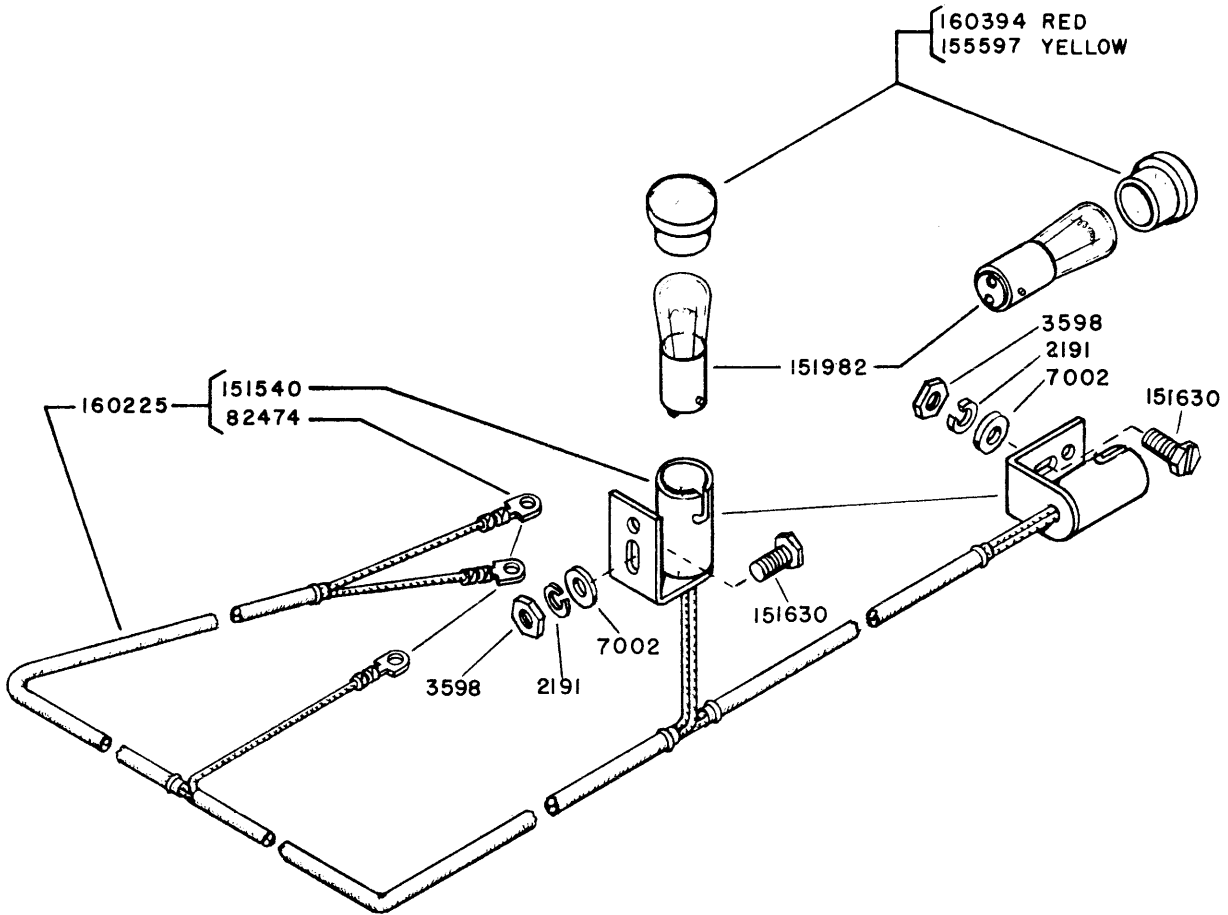


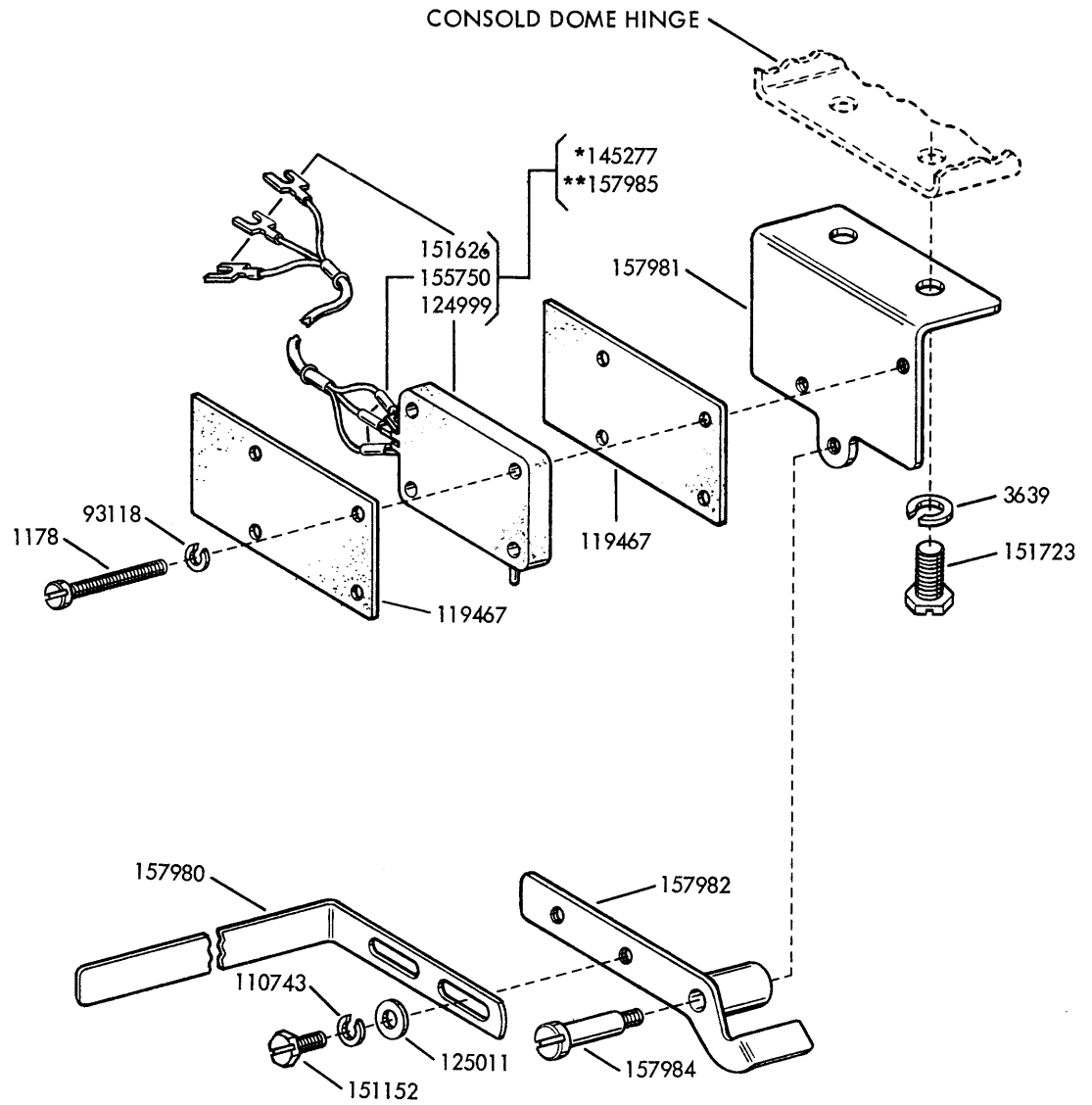
FIGURE 5-17. VARIABLE FEATURES FOR LAC205\*\* CONSOLE CABINET





Specification 5879S

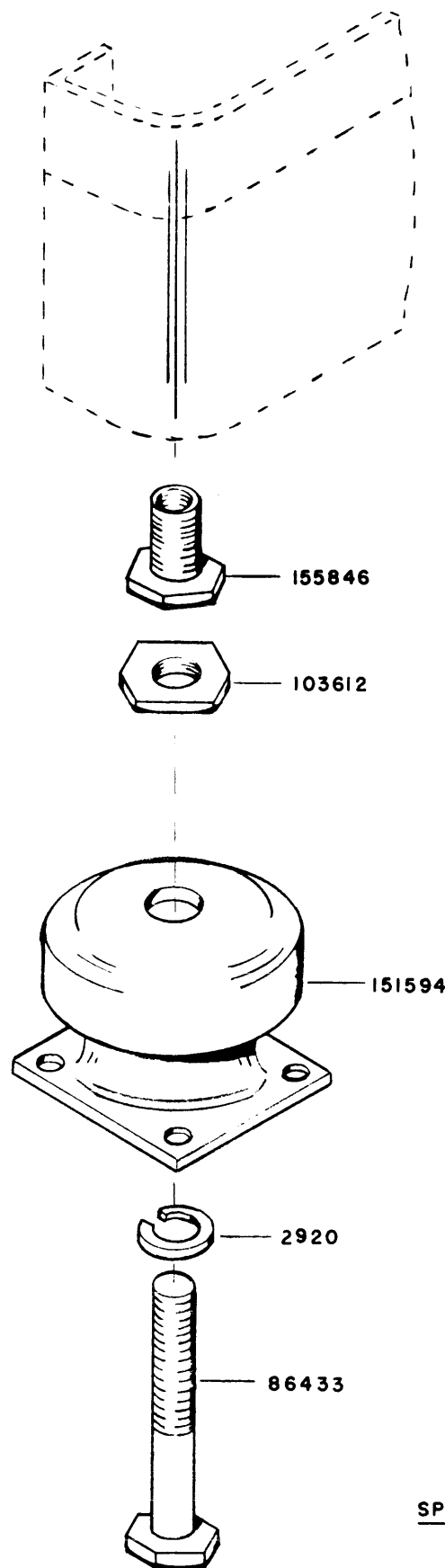
FIGURE 5-18. 160224 MODIFICATION KIT TO ADD OPEN AND BUSY LINE INDICATOR LIGHTS



\*PECULIAR TO 145278 MODIFICATION KIT  
 \*\*PECULIAR TO 154756 MODIFICATION KIT

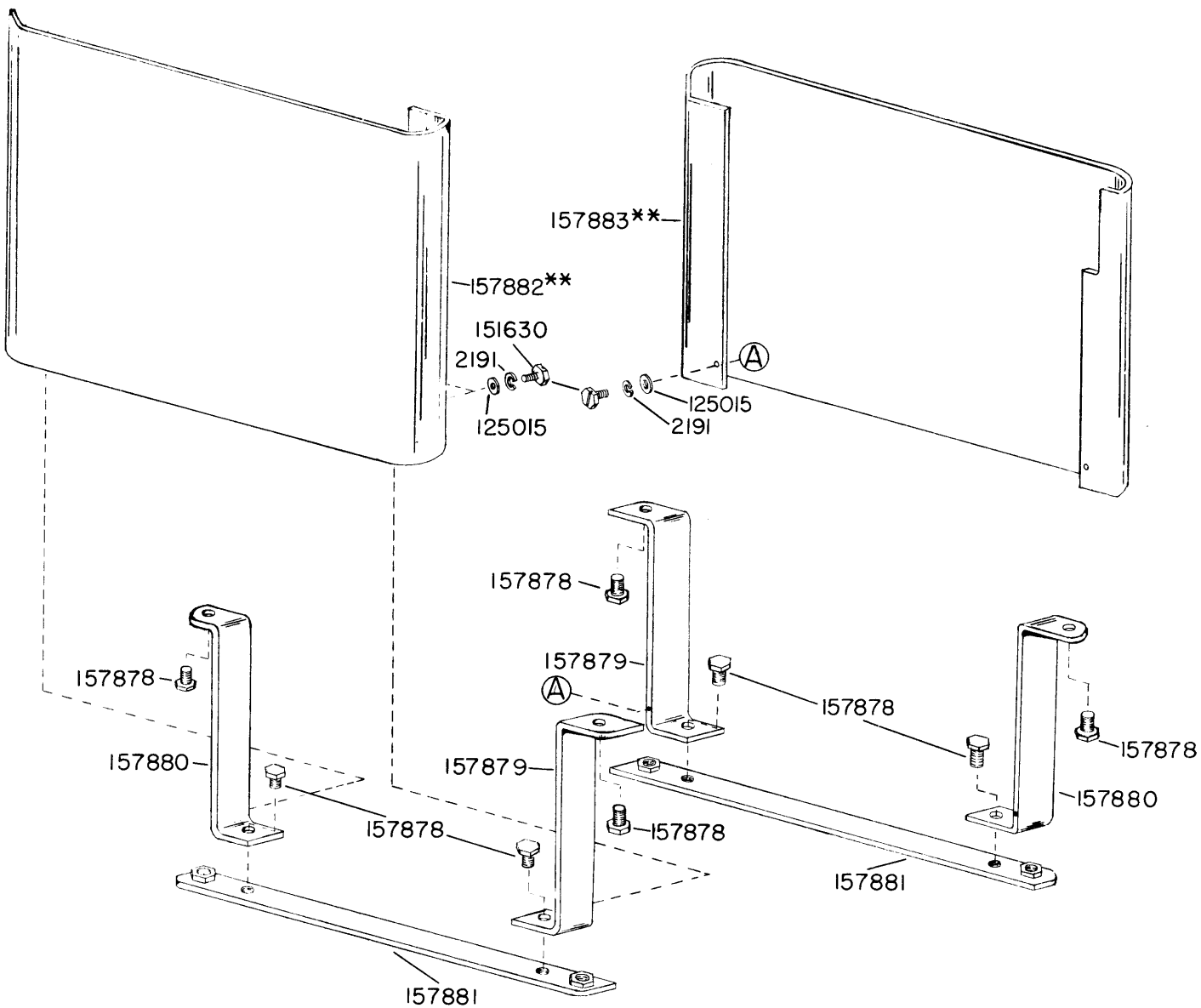
FIGURE 5-19. 145278 AND 154756 MODIFICATION KITS TO ADD FORM-OUT ALARM MECHANISM (CONSOLE MODEL)

1149B



SPECIFICATION 5739S

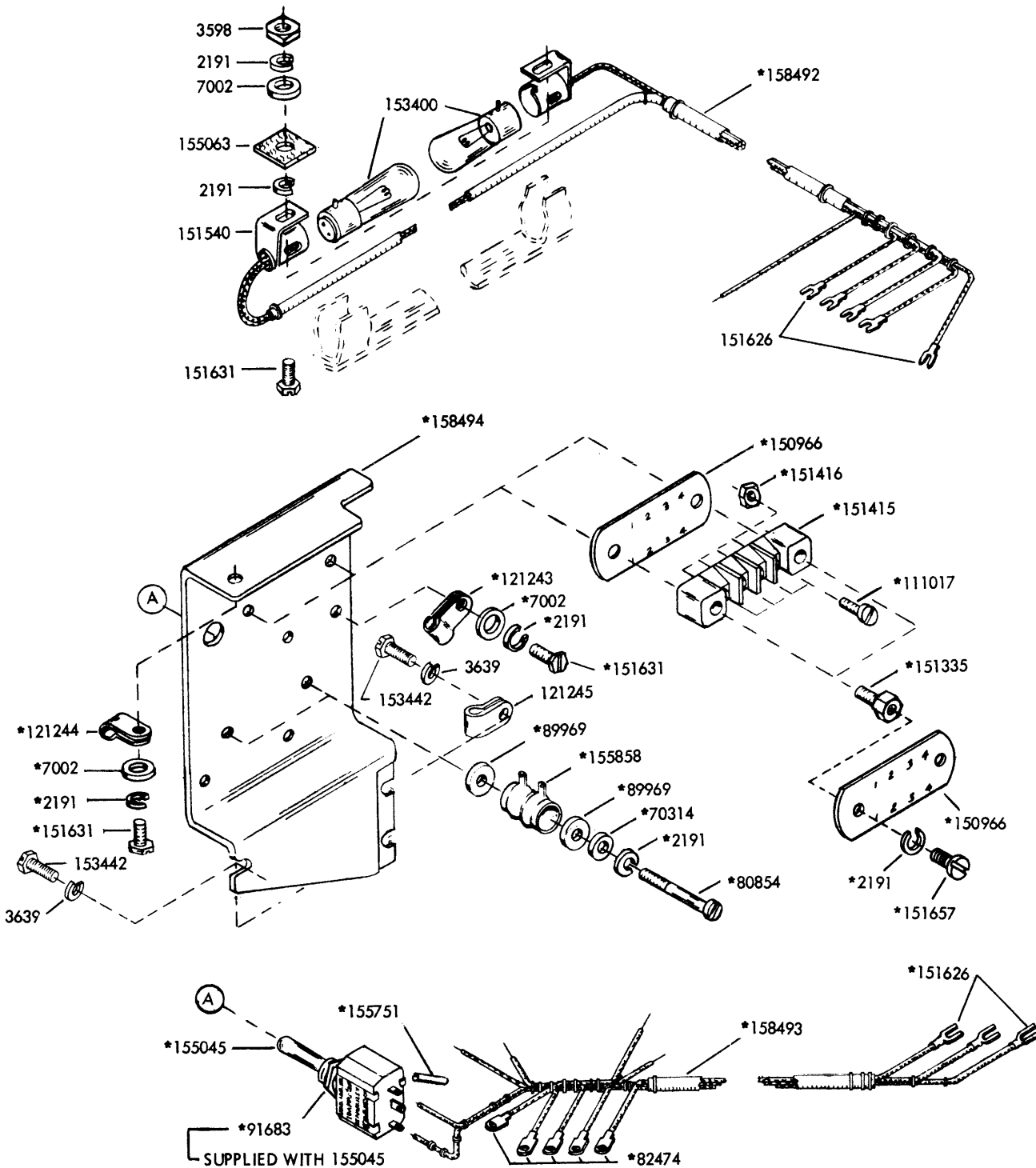
FIGURE 5-20. 154793 MODIFICATION KIT TO ADD SHOCK MOUNTS TO A CONSOLE CABINET



\*\* SEE CHART ON PAGE J FOR COLOR SUFFIX.

SPECIFICATION 5846S

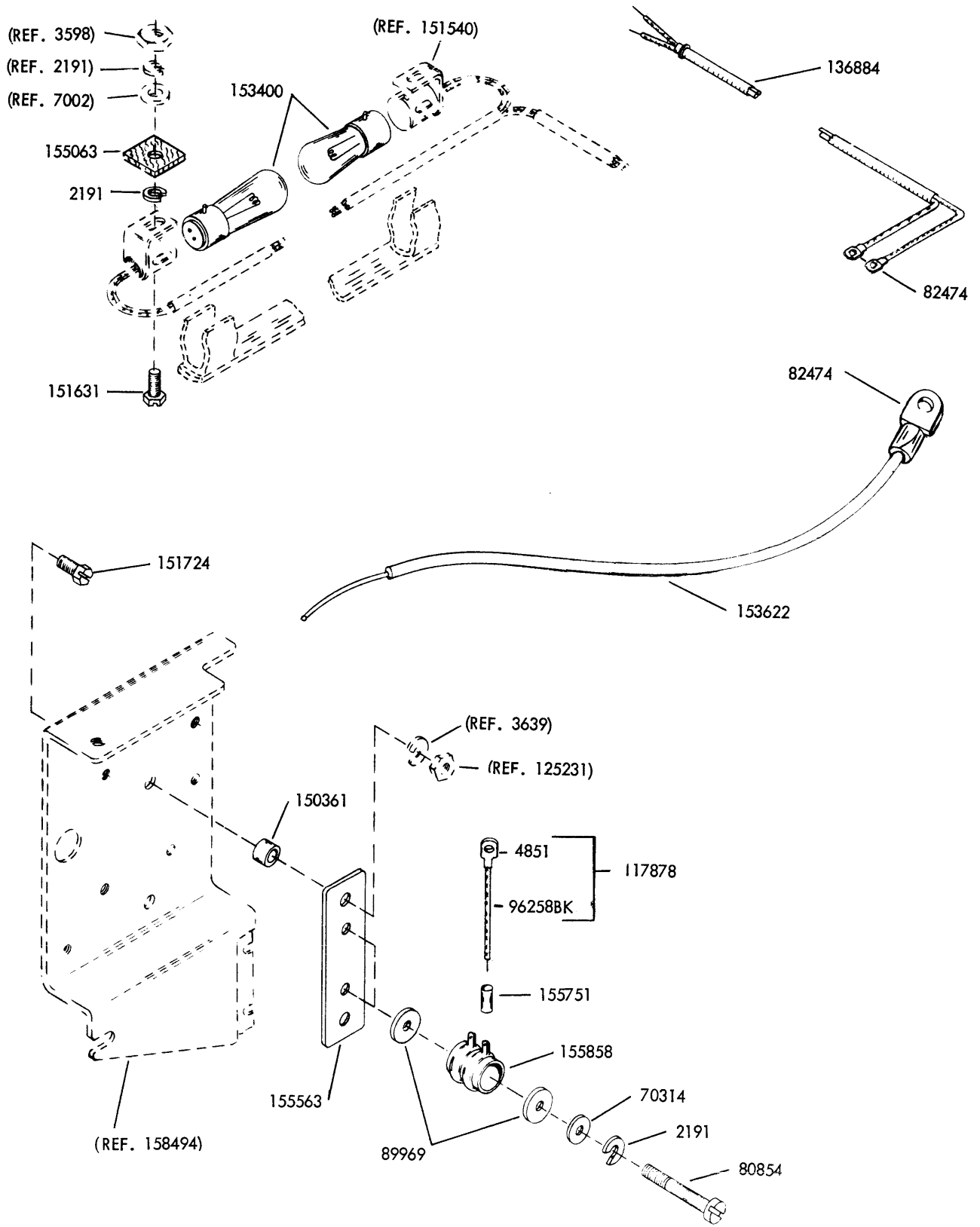
FIGURE 5-21. 154754\*\* MODIFICATION KIT TO PROVIDE A SUB-BASE FOR AN LAC202\*\* OR LAC204\*\* CONSOLE CABINET



NOTE:  
158491 COPYLIGHT ASSEMBLY  
CONSISTS OF PARTS MARKED  
WITH AN ASTERISK (\*).

SPECIFICATION 58535

FIGURE 5-22. 154777 MODIFICATION KIT TO PROVIDE D.C. INCANDESCENT COPYLIGHT SYSTEM



SPECIFICATION 5853S

FIGURE 5-23. 159375 MODIFICATION KIT TO CONVERT AN A.C. COPYLIGHT SYSTEM TO A 60 VOLT D.C. COPYLIGHT SYSTEM

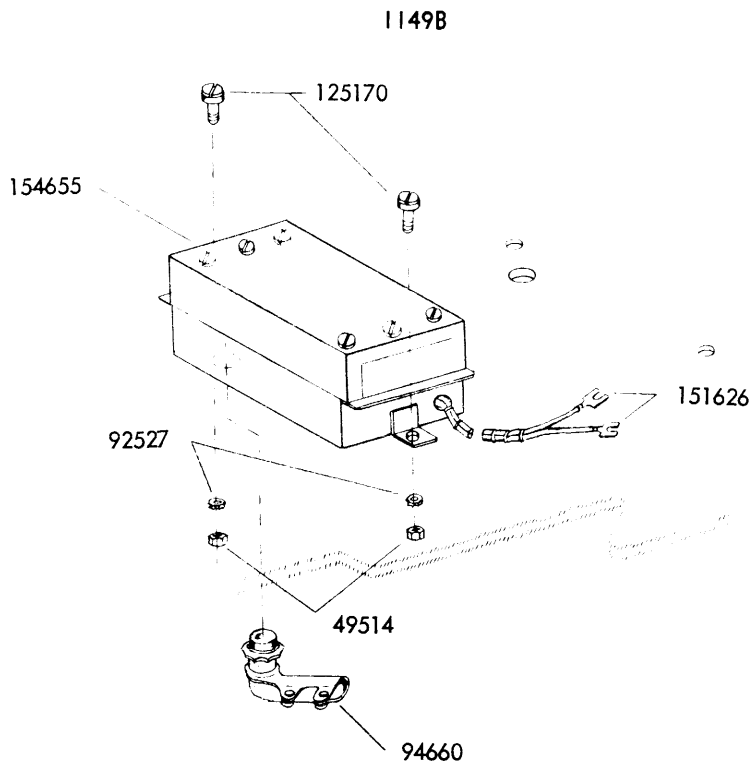


FIGURE 5-24. 154651 MODIFICATION KIT TO ADD SIGNAL LINE ELECTRICAL NOISE SUPPRESSOR (D.C.)

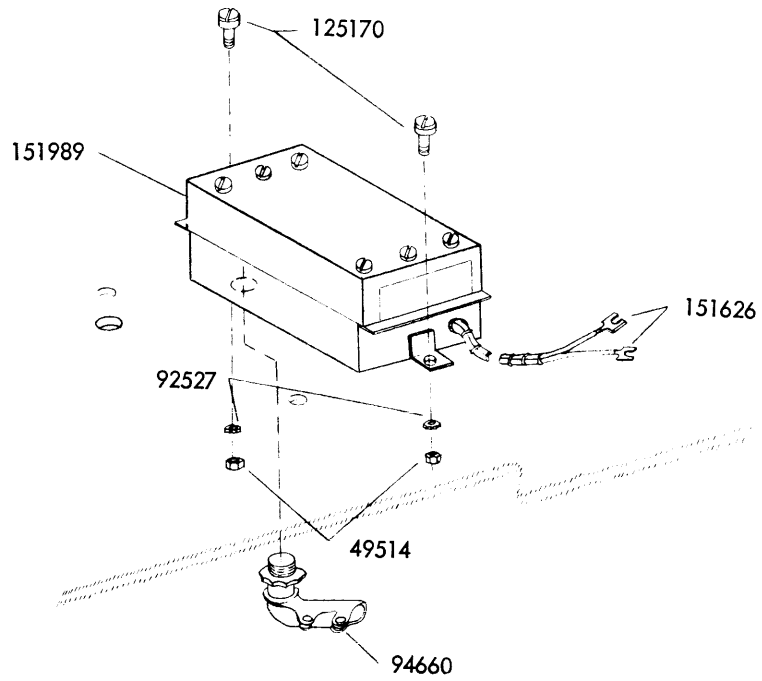
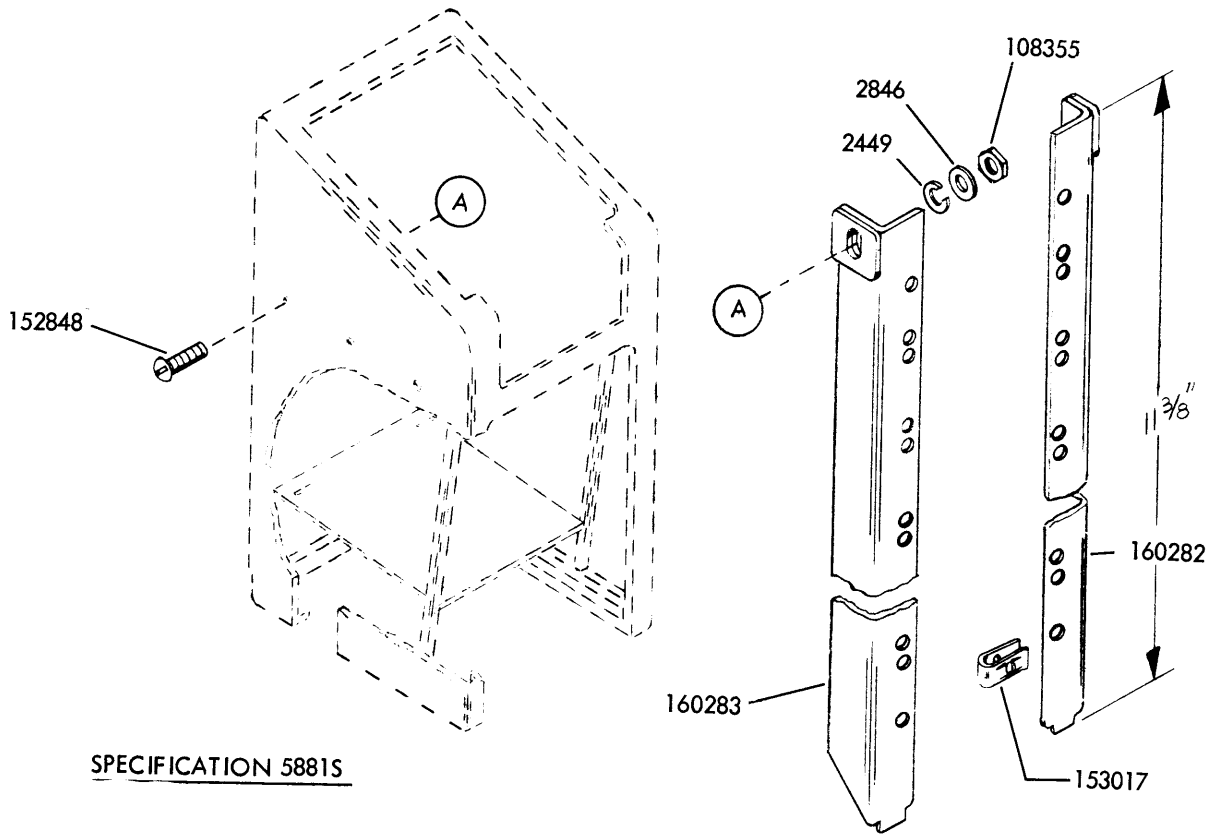
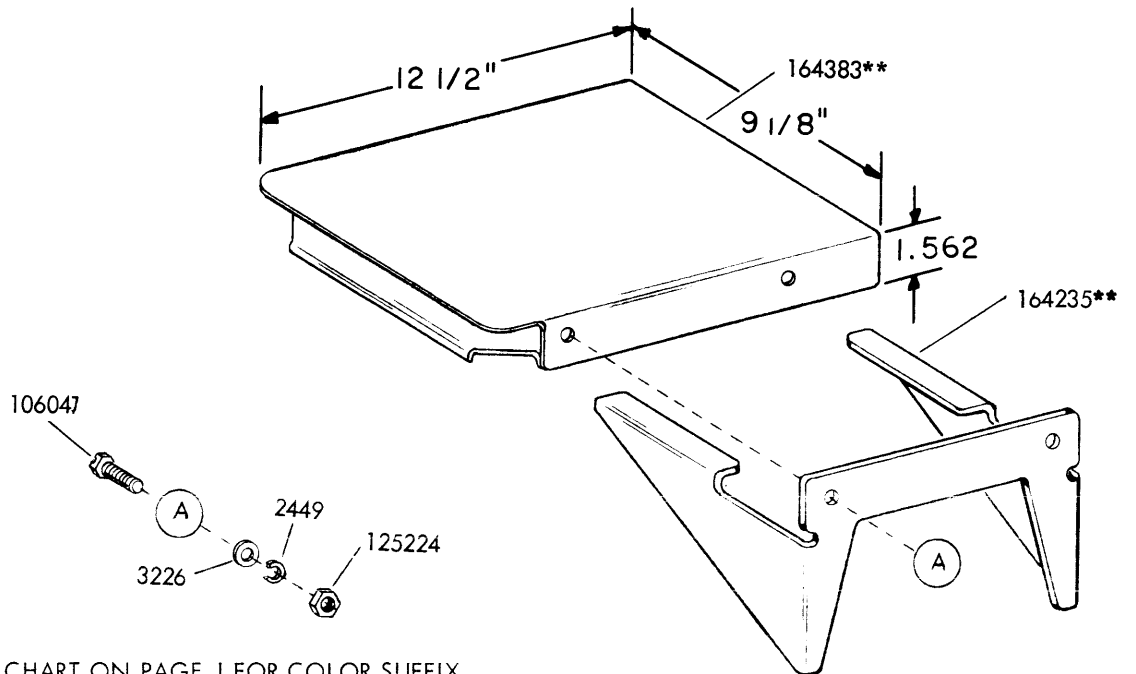


FIGURE 5-25. 151988 MODIFICATION KIT TO ADD POWER LINE ELECTRICAL NOISE SUPPRESSOR



SPECIFICATION 5881S

FIGURE 5-26. 159390 MODIFICATION KIT TO PROVIDE AN APPARATUS MOUNTING RACK IN AN LAC205\*\* CONSOLE CABINET.



\*\* SEE CHART ON PAGE J FOR COLOR SUFFIX

FIGURE 5-27. 163796\*\*MODIFICATION KIT TO PROVIDE SHELF FOR CONSOLE CABINET



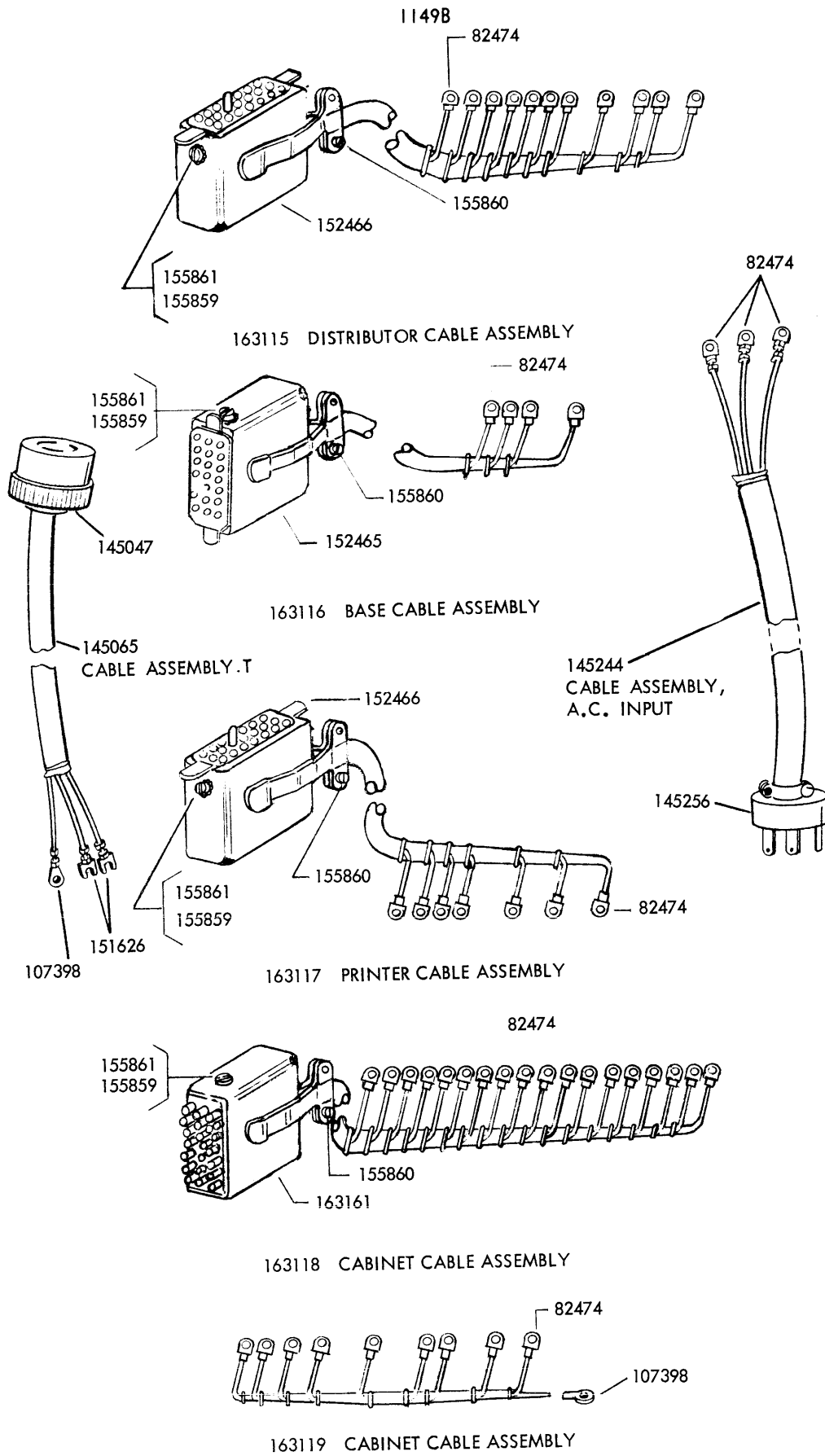
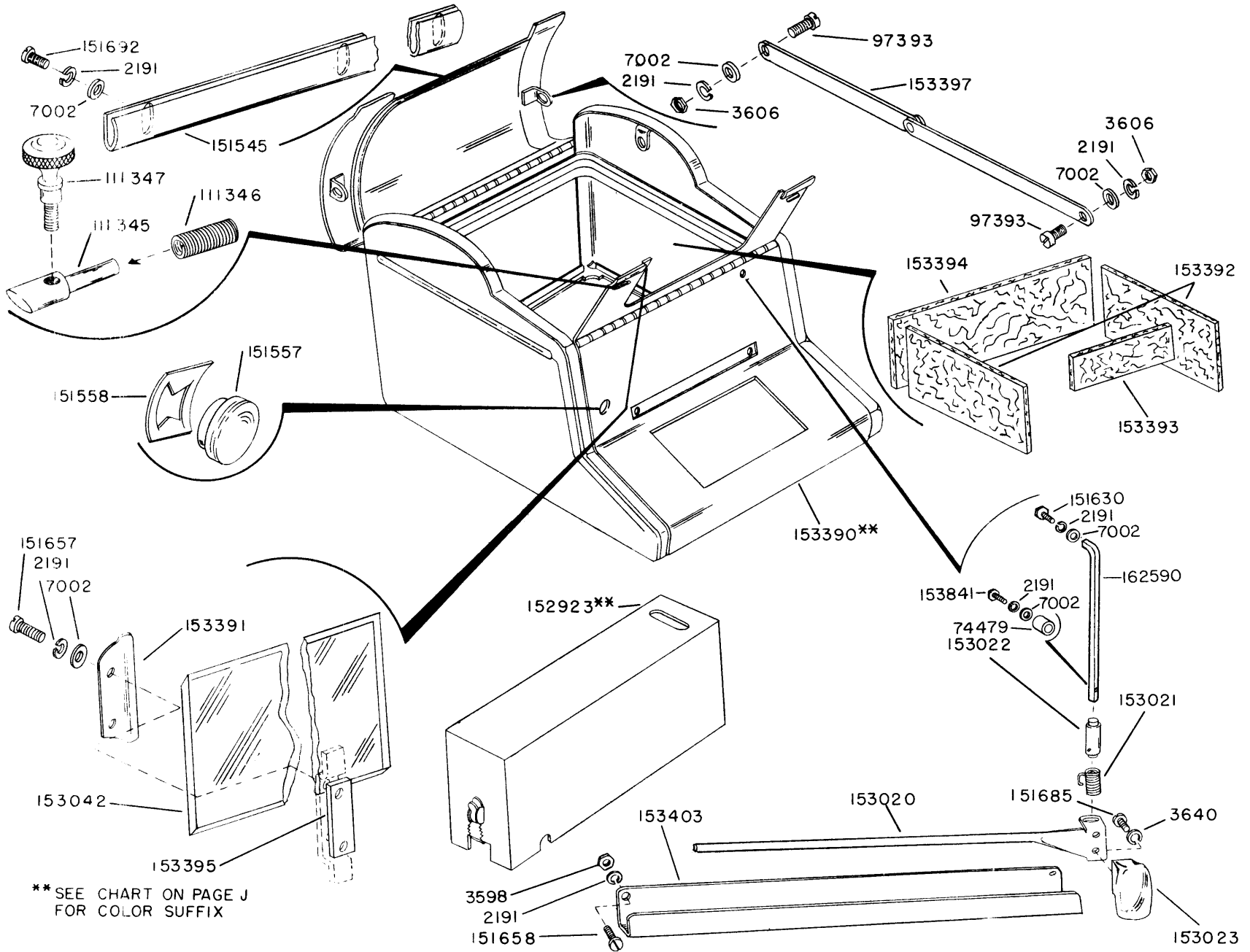


FIGURE 5-28. CABLES FOR THE LAC213\*\* AND LAC215\*\* CABINETS

FIGURE 5-29 COVER ASSEMBLY



\*\* SEE CHART ON PAGE J FOR COLOR SUFFIX

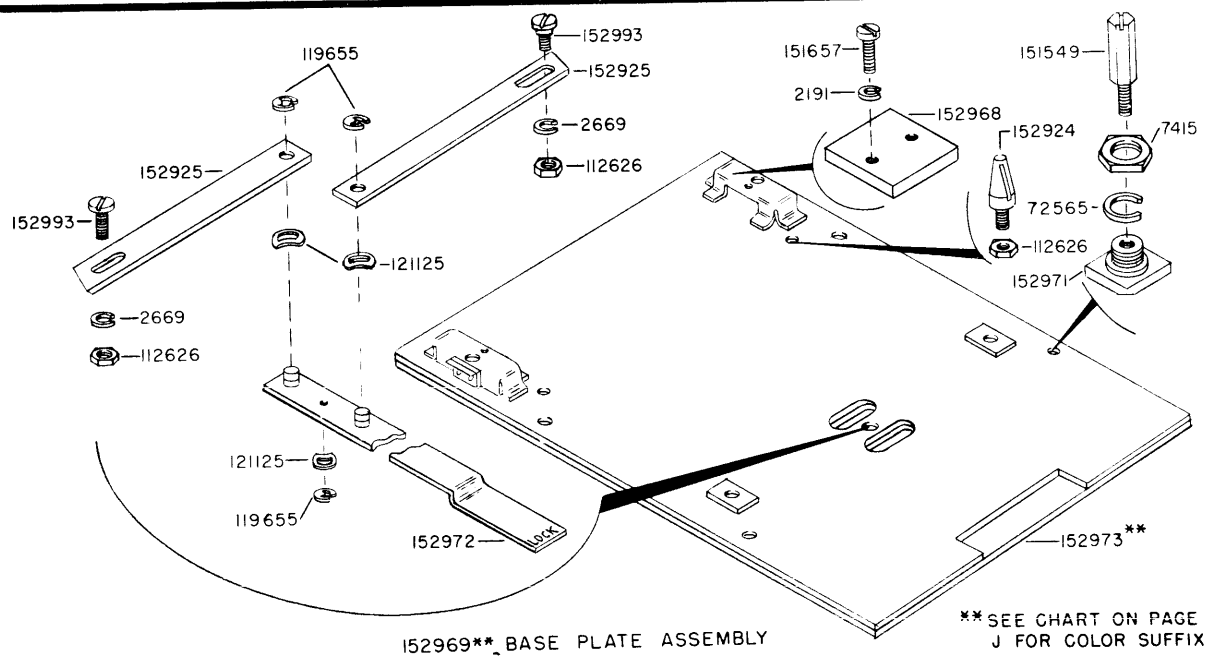
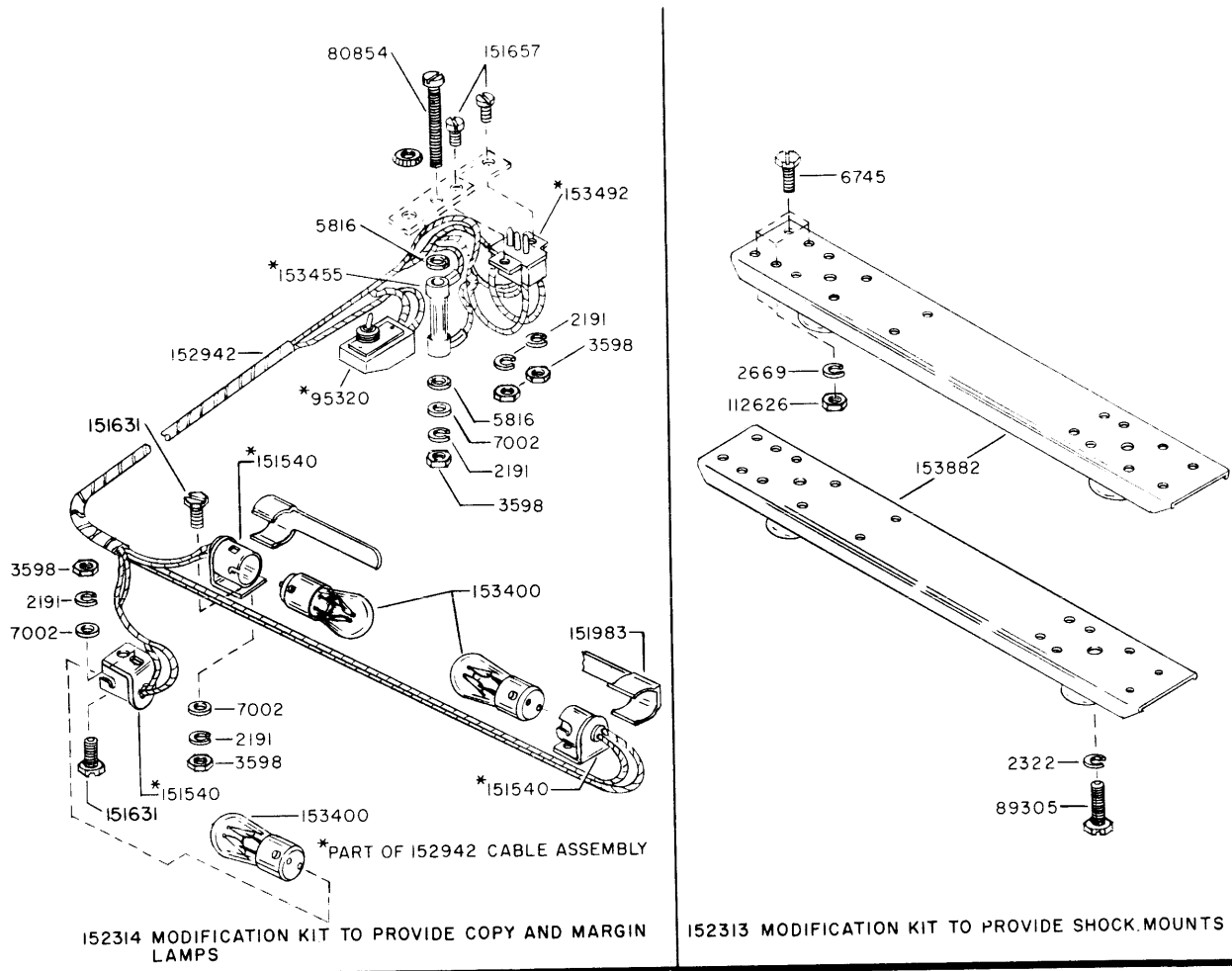
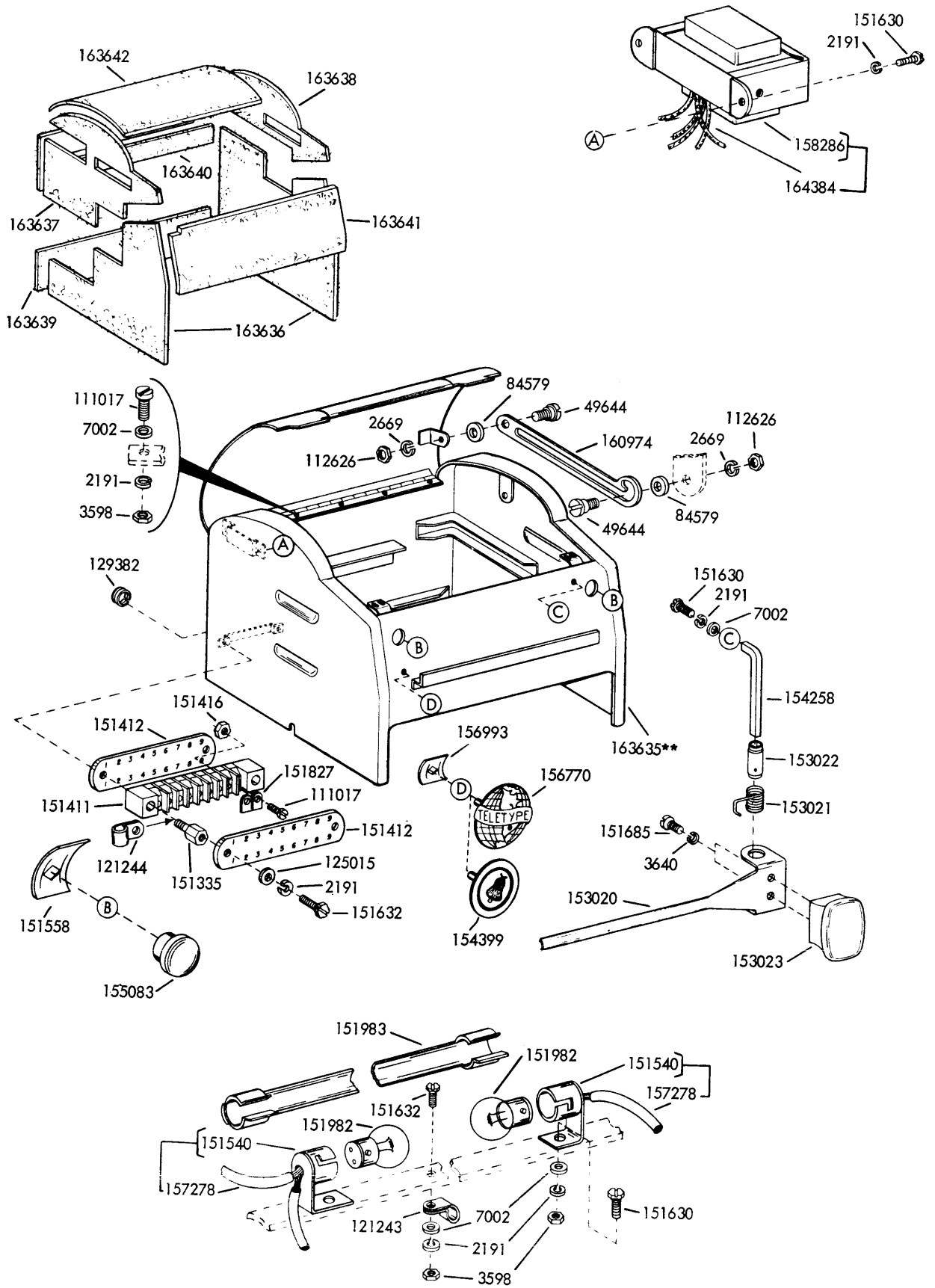


FIGURE 5-30. VARIABLE FEATURES FOR LPC202\*\* AND LPC203\*\* COVERS



\*\*SEE CHART ON PAGE J FOR COLOR SUFFIX

FIGURE 5-31. LPC204\*\* AND LPC205\*\* COVERS  
(ALSO SEE FIGURE 5-32)

1149B

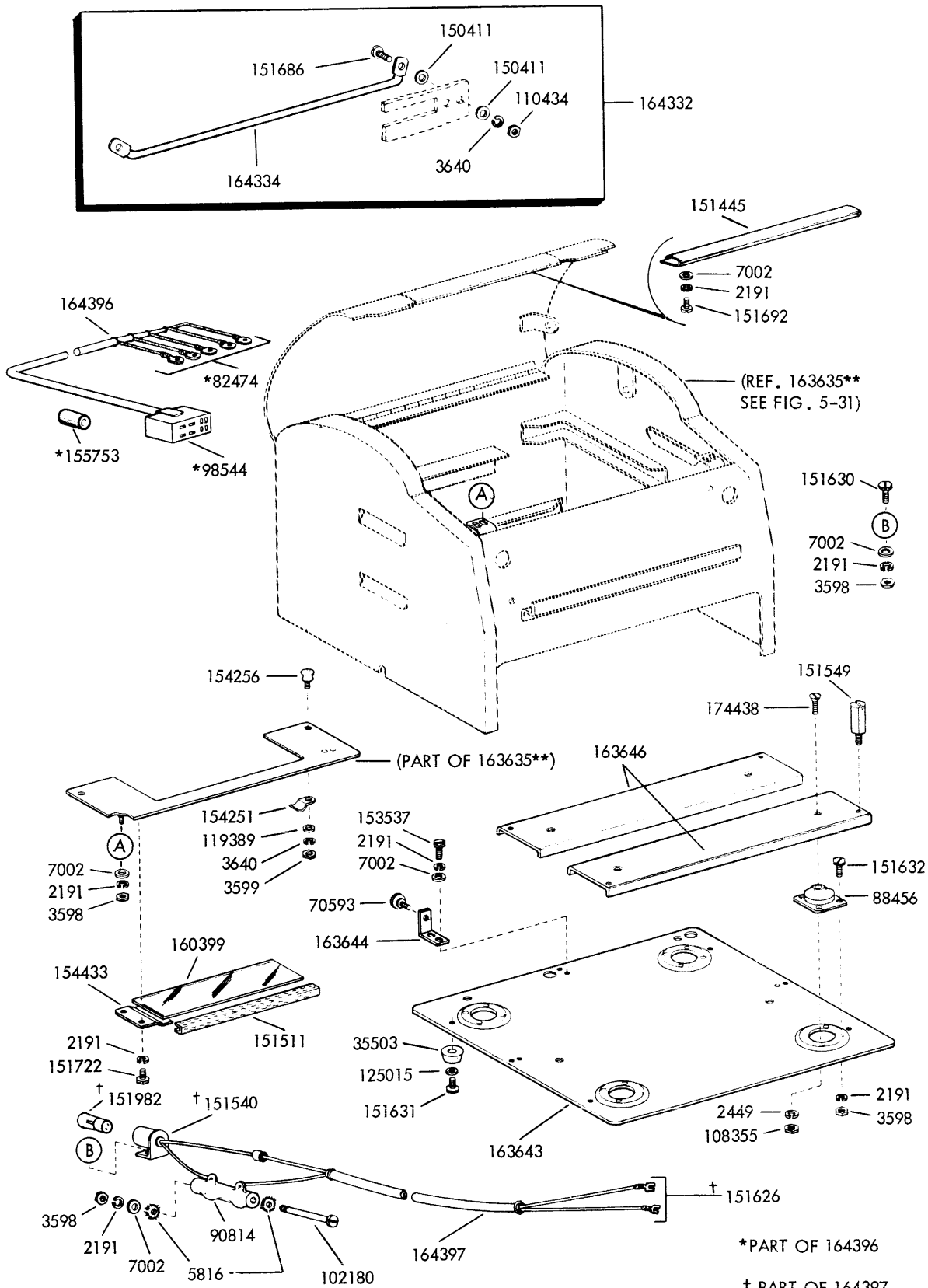


FIGURE 5-32. VARIABLE FEATURES FOR LPC204\*\* AND LPC205\*\* COVERS

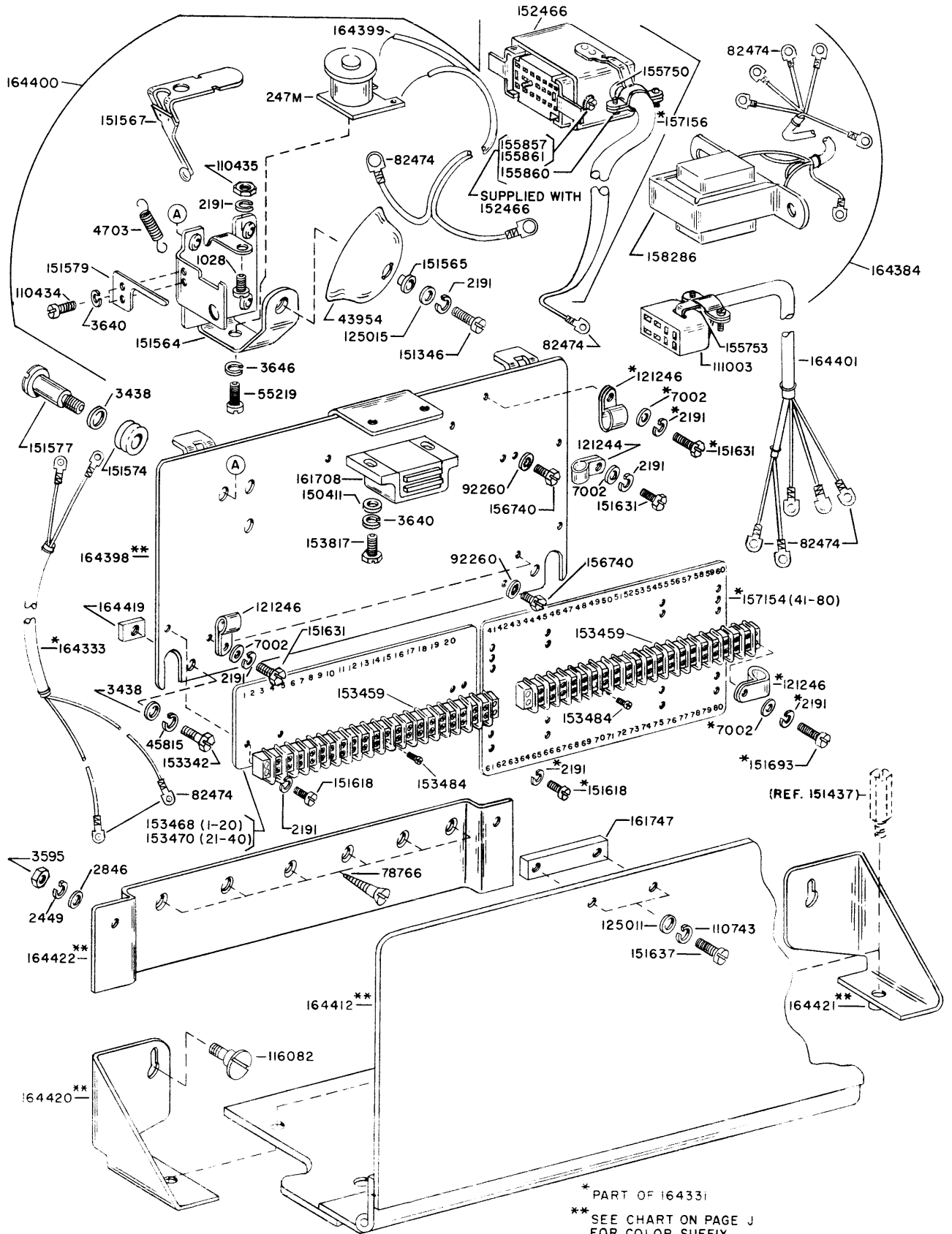


FIGURE 5-33. 164345\*\* MODIFICATION KIT TO EQUIP AN ELECTRICAL SERVICE UNIT WITH AUXILIARY TERMINAL BLOCKS (EXCLUDES PARTS MARKED\*)  
 164331 MODIFICATION KIT TO ADD TERMINAL BLOCKS AND CABLES FOR SELECTIVE CALLING (INCLUDES PARTS MARKED\*)

\* PART OF 164331  
 \*\* SEE CHART ON PAGE J FOR COLOR SUFFIX.

1149B

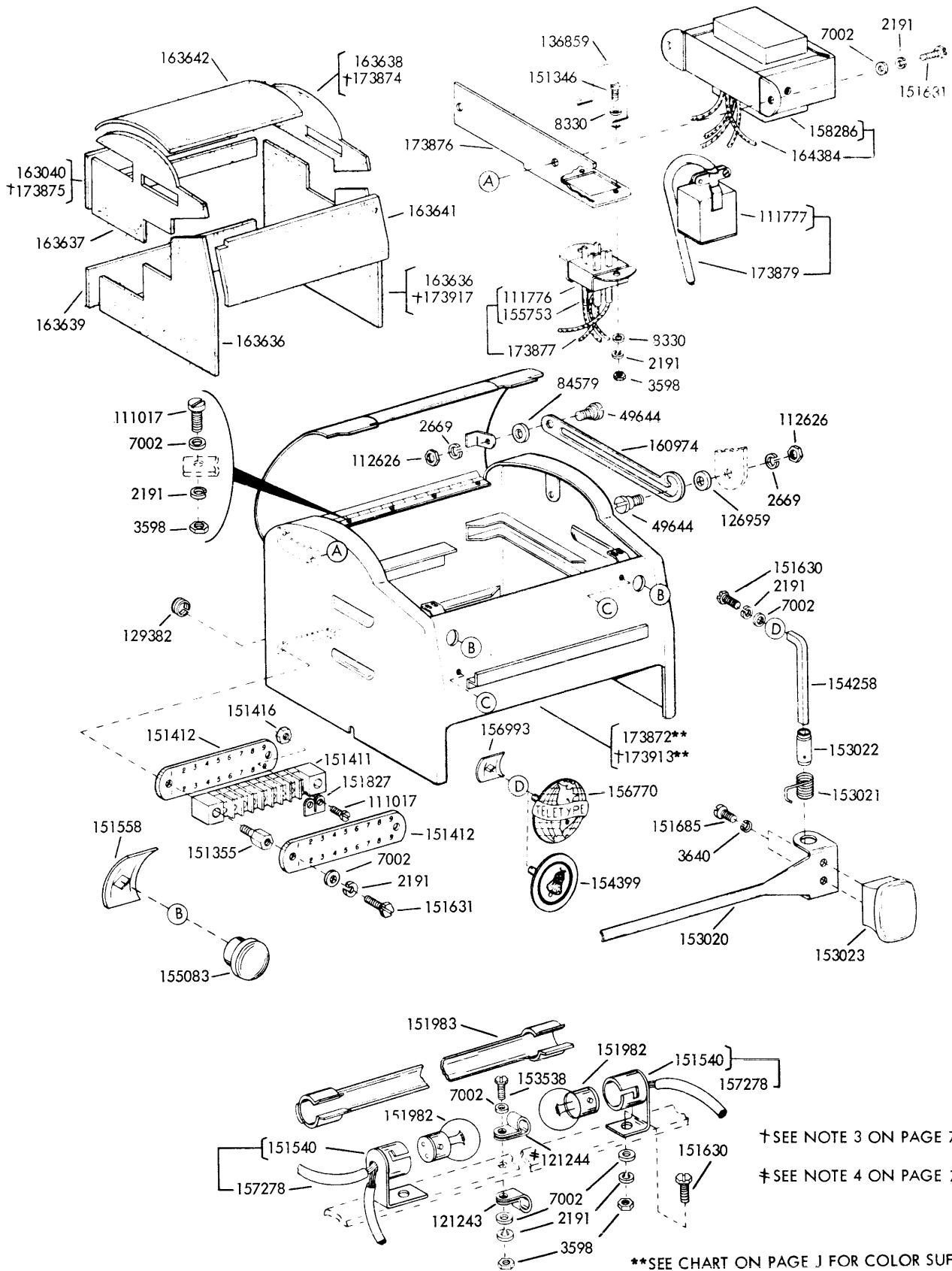


FIGURE 5-34. LPC206\*\* AND LPC207\*\* COVERS

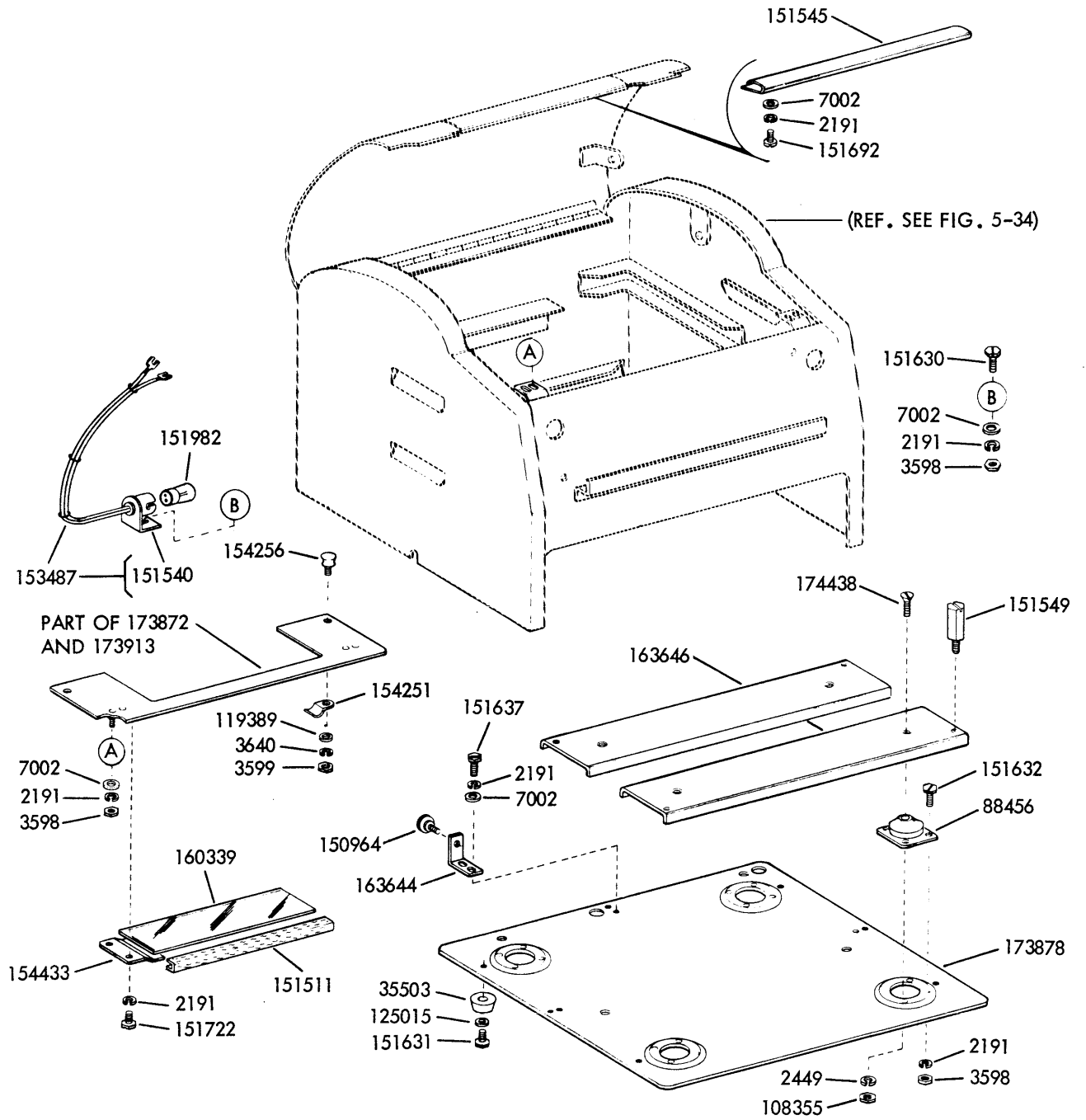


FIGURE 5-35. VARIABLE FEATURES FOR LPC206\*\* AND LPC207\*\*



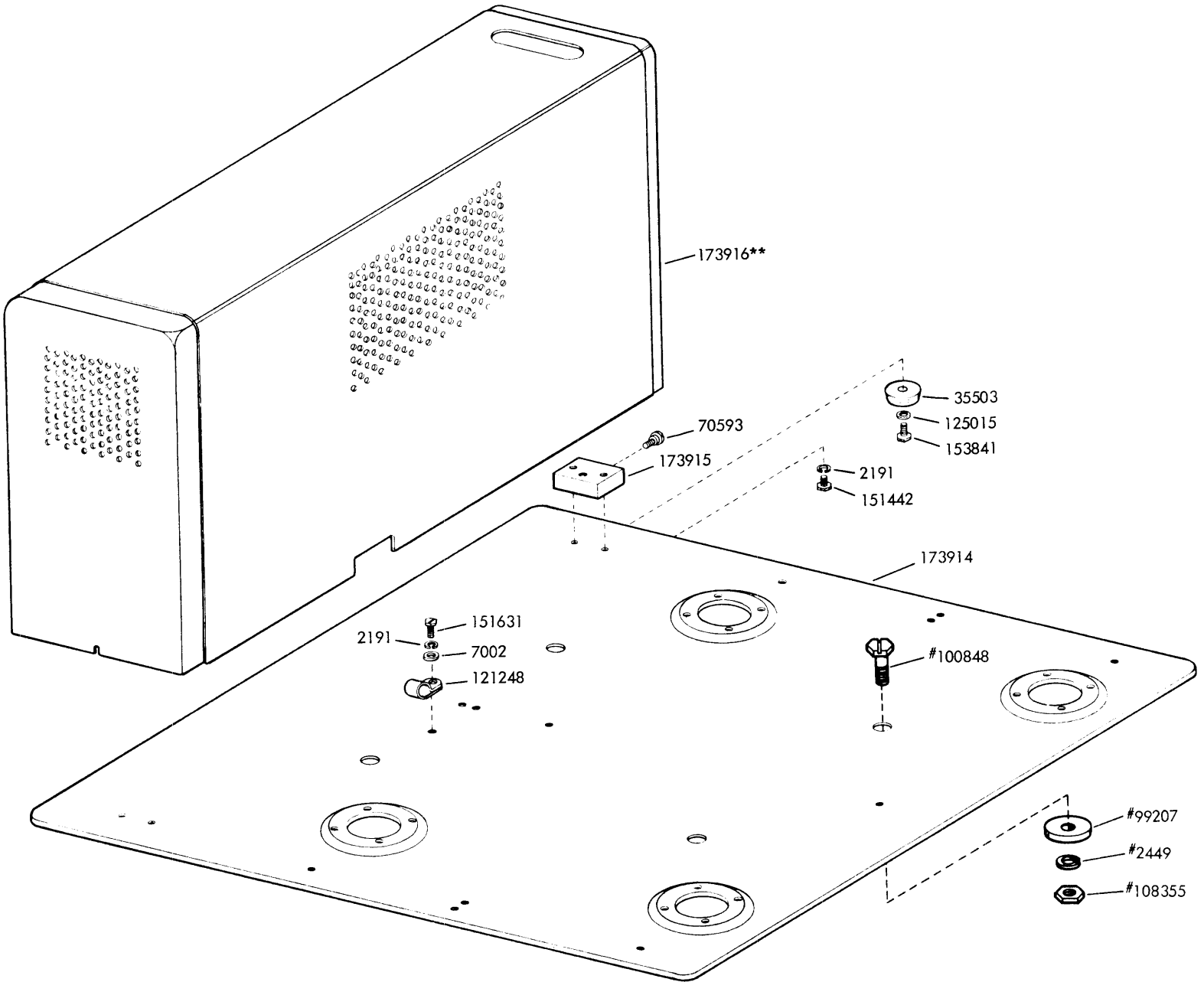


FIGURE 5-36. VARIABLE FEATURES FOR LPC207\*\*

#SEE NOTE 5 ON PAGE 7-6  
\*\*SEE CHART ON PAGE J FOR COLOR SUFFIX

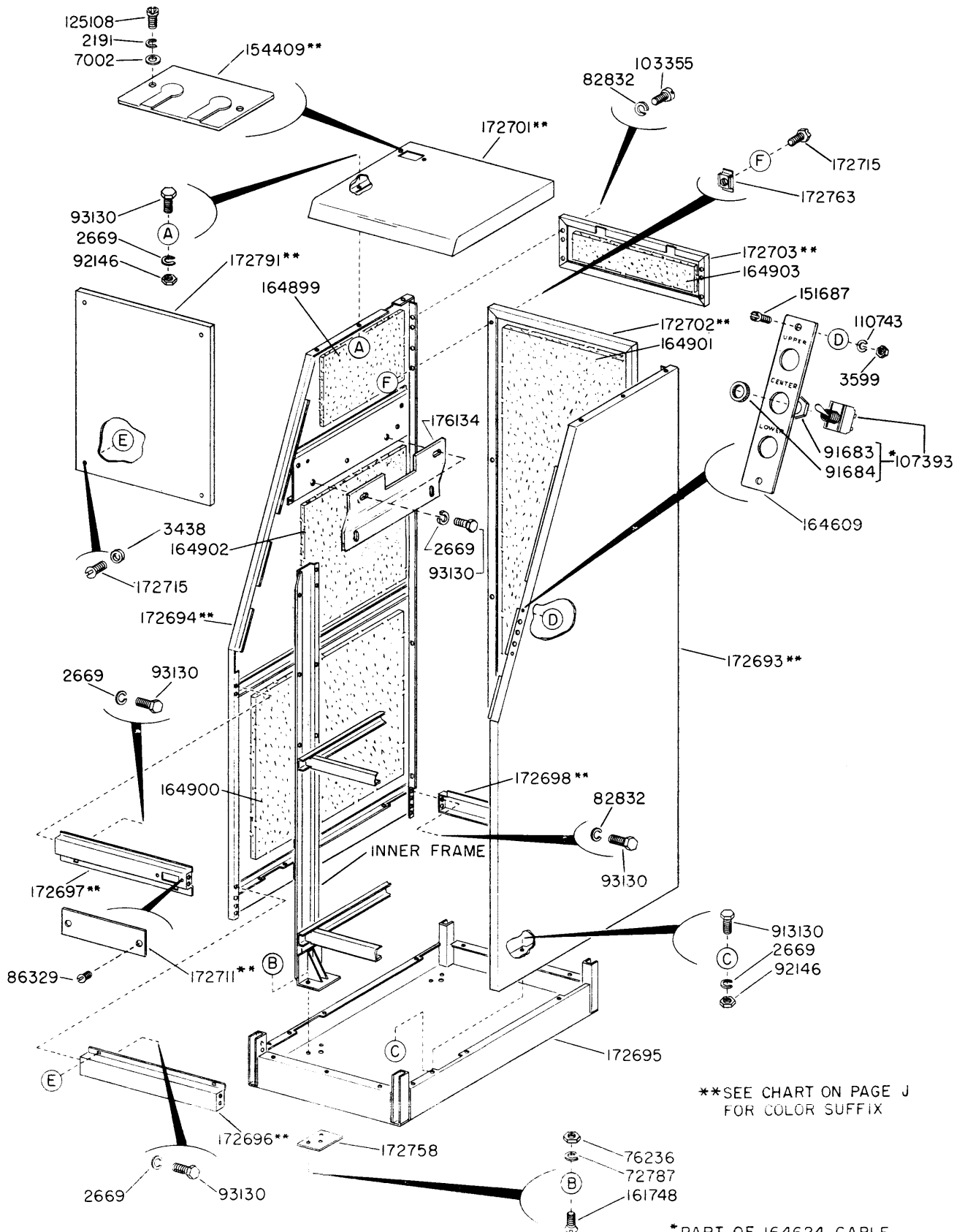


FIGURE 5-37. CABINET BODY ASSEMBLY (LBAC211\*\*)

1149B

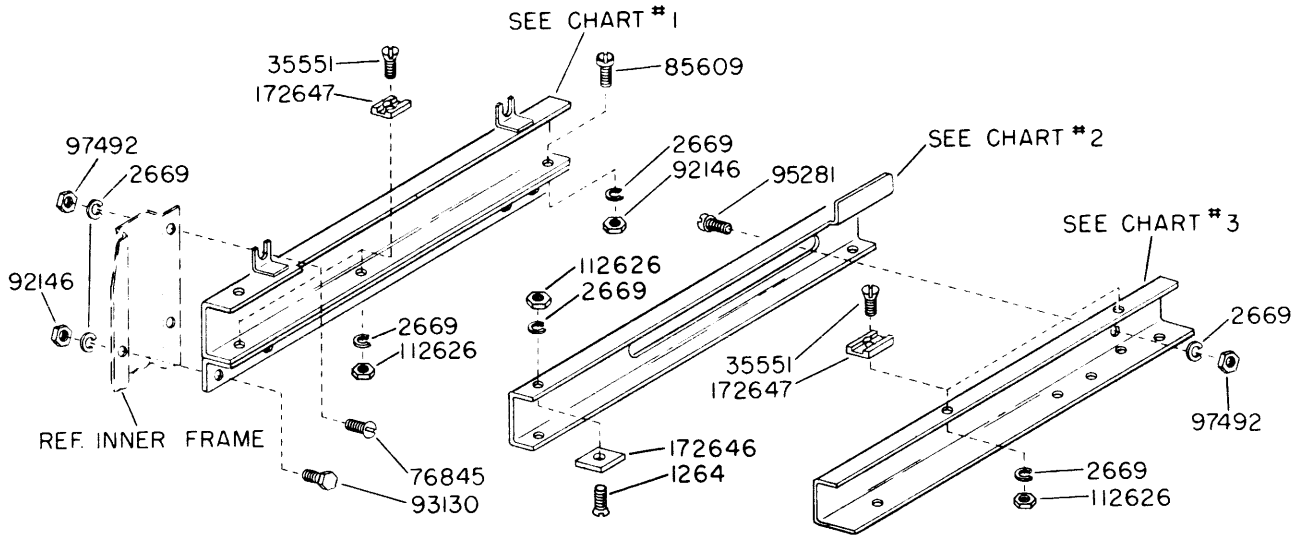
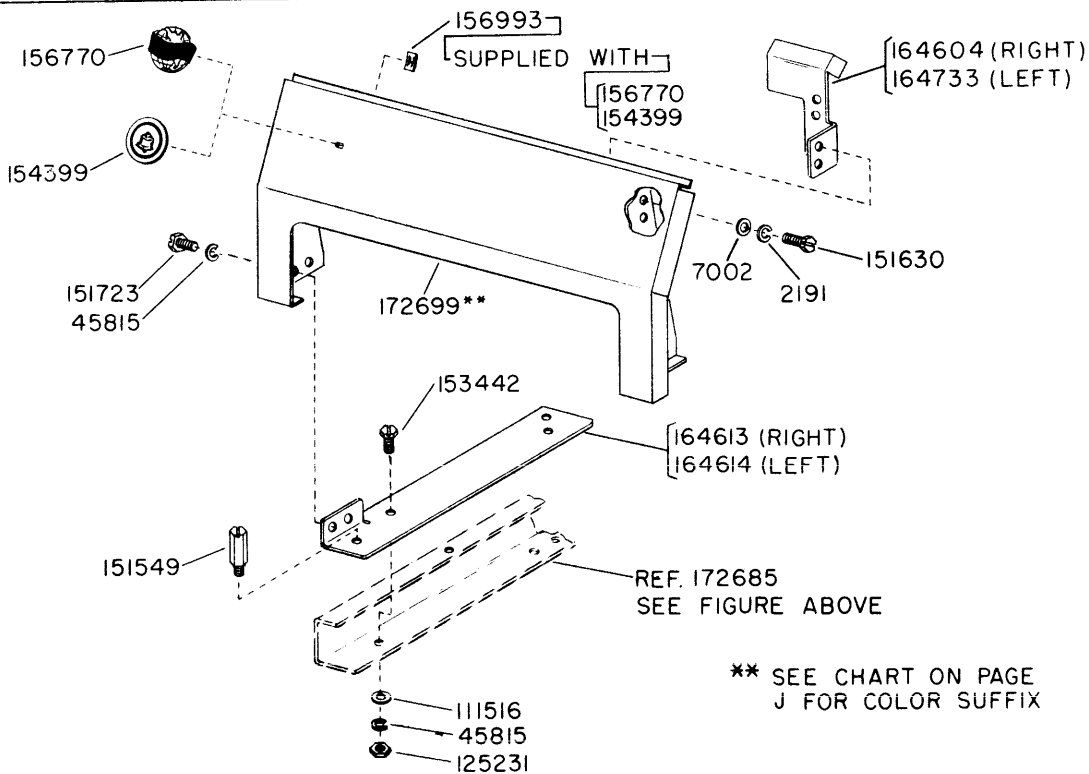


CHART # 1		
DRAWER LOCATION	SIDE	PART NUMBER
TOP	LEFT	172650
	RIGHT	172651
CENTER	LEFT	172654
	RIGHT	172655
BOTTOM	LEFT	172659
	RIGHT	172658

CHART # 2		
DRAWER LOCATION	SIDE	PART NUMBER
TOP	LEFT	172683
CENTER BOTTOM	RIGHT	172682

CHART # 3		
DRAWER LOCATION	SIDE	PART NUMBER
TOP	LEFT	172685
CENTER BOTTOM	RIGHT	172684

FIGURE 5-38. SLIDE MECHANISM (LBAC211\*\*)



\*\* SEE CHART ON PAGE J FOR COLOR SUFFIX

FIGURE 5-39. SEND-RECEIVE KEYBOARD COVER (LBAC211\*\*)

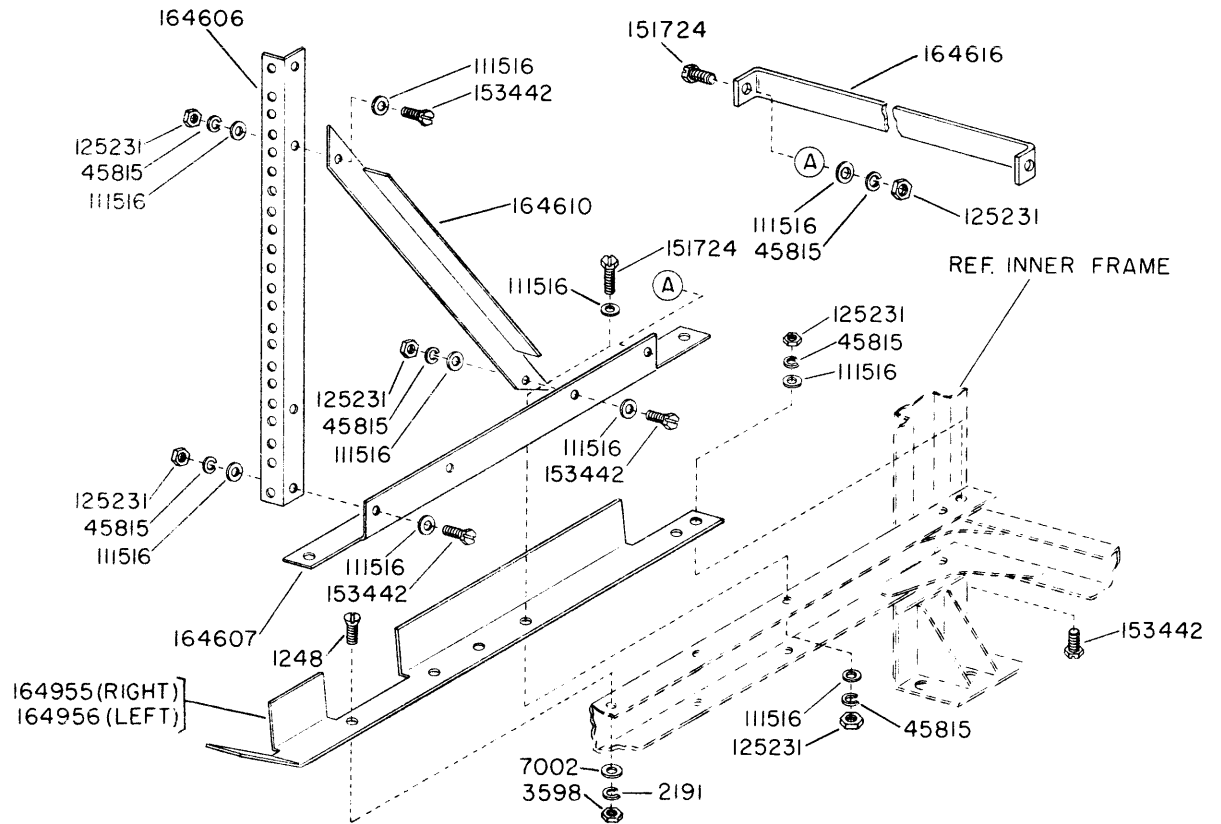


FIGURE 5-40. RELAY RACK FRAME ASSEMBLY

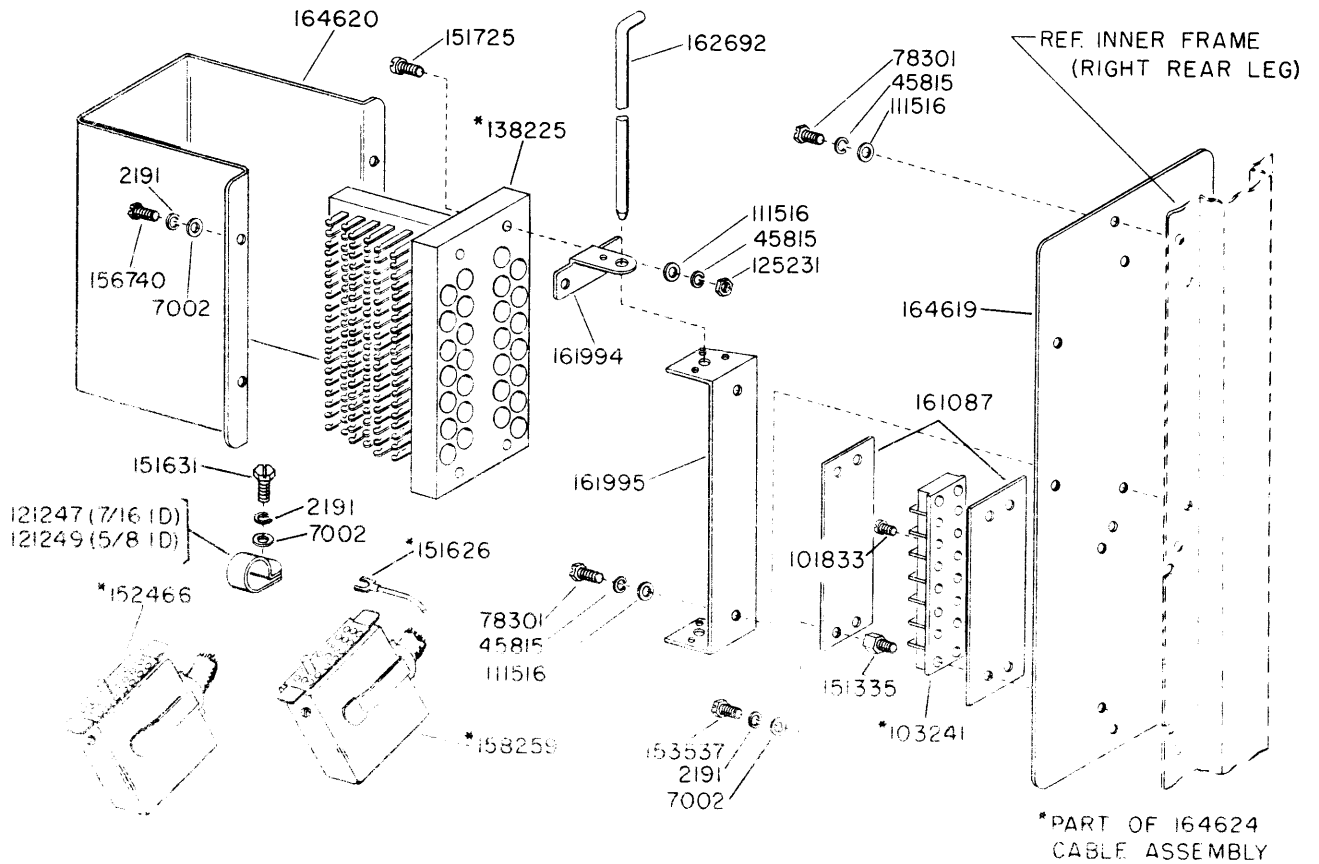


FIGURE 5-41. TERMINAL BLOCKS AND CABLE CONNECTORS

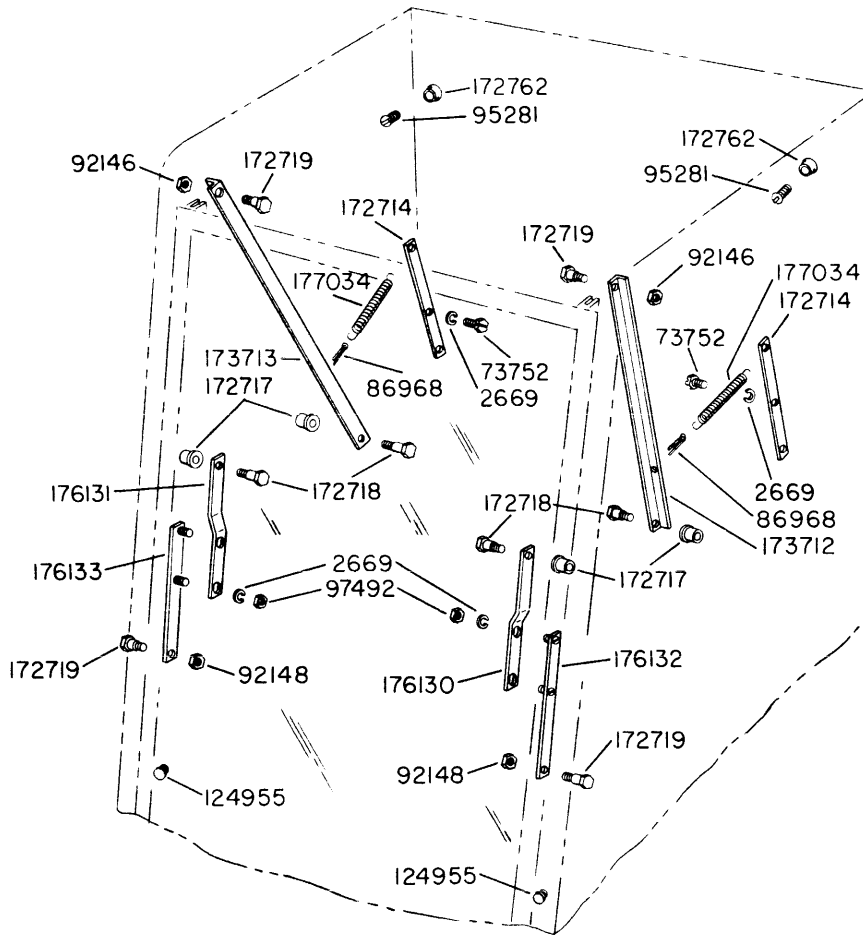
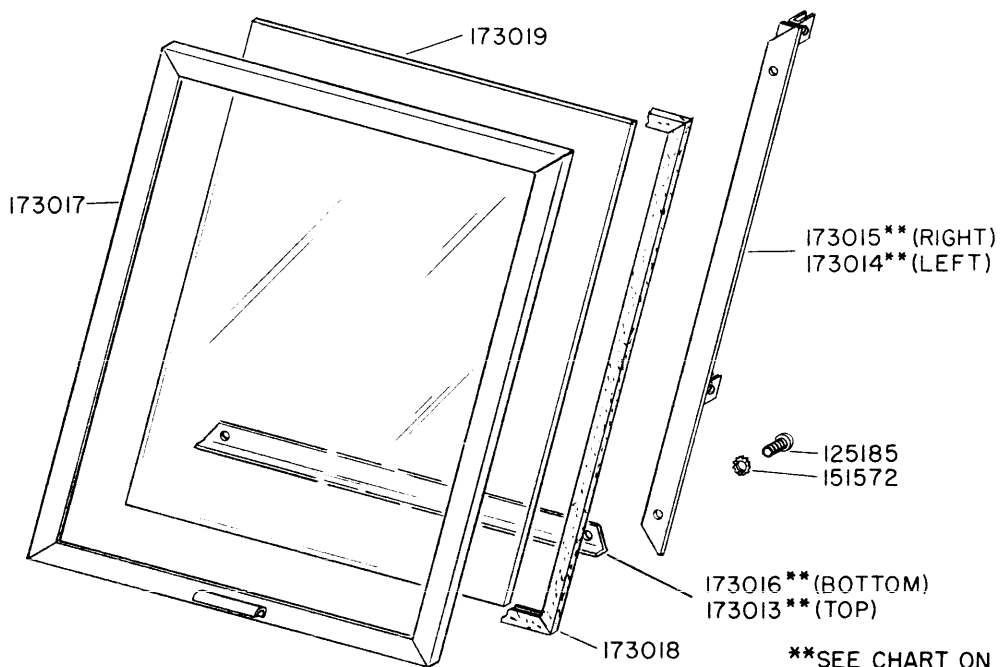


FIGURE 5-42. DOOR ARM MECHANISM



\*\*SEE CHART ON PAGE J FOR COLOR SUFFIX

FIGURE 5-43. 172700\*\* DOOR ASSEMBLY

FIGURE 5-44. RECEIVING ONLY BASE PLATE (LBAC211\*\*)

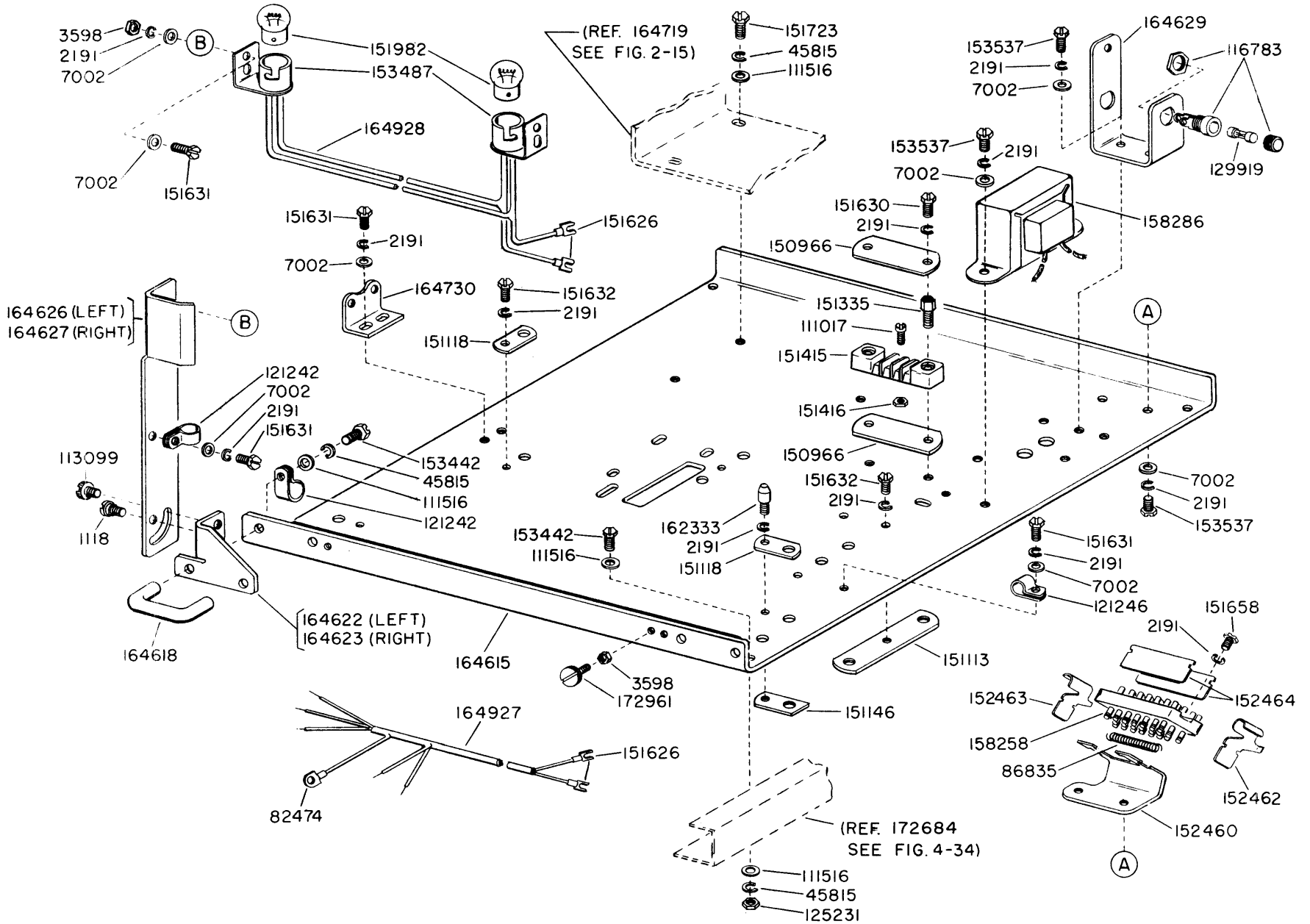
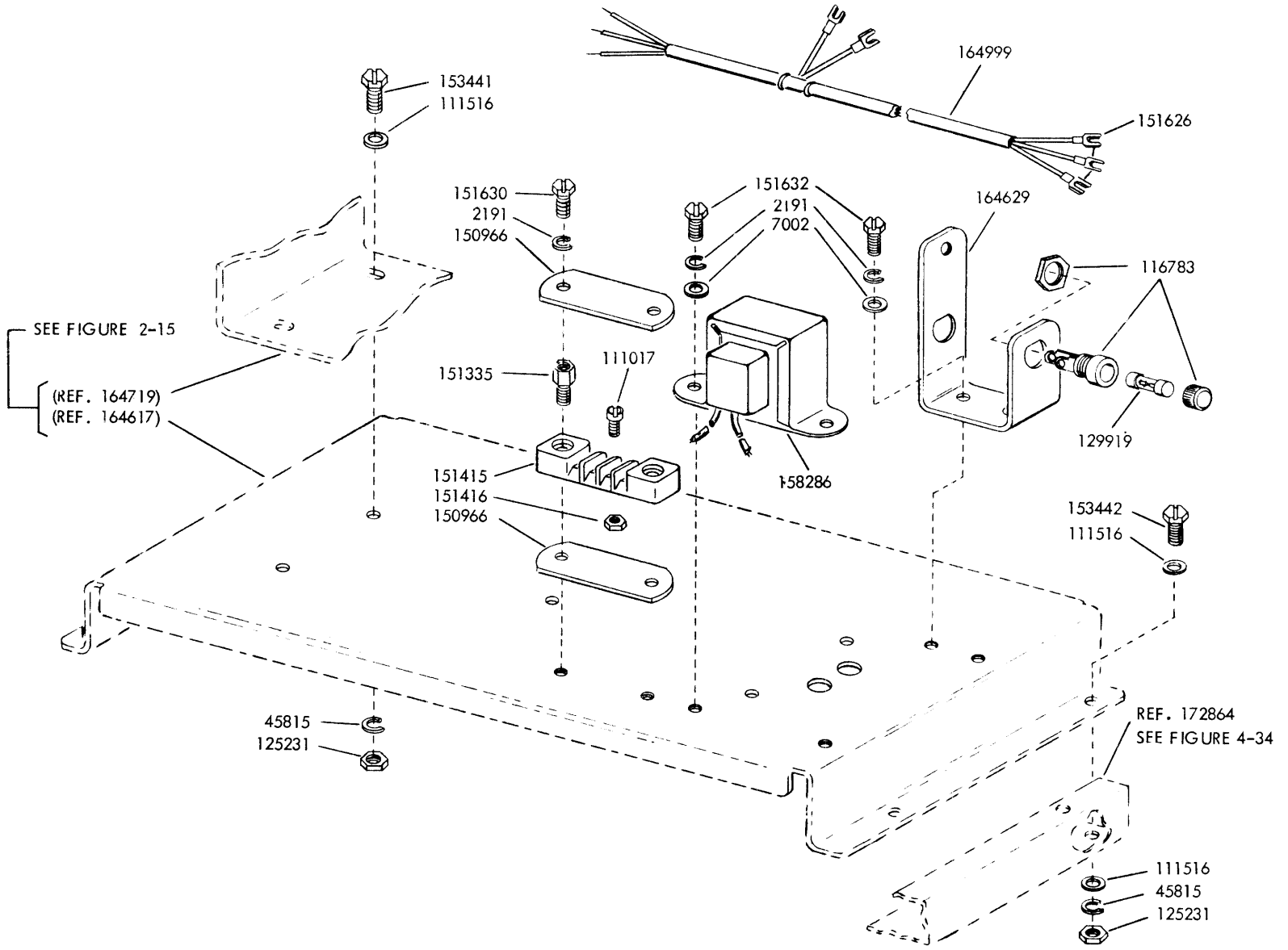


FIGURE 5-45. PAPER WINDER SHELF FOR SEND-RECEIVE BASE



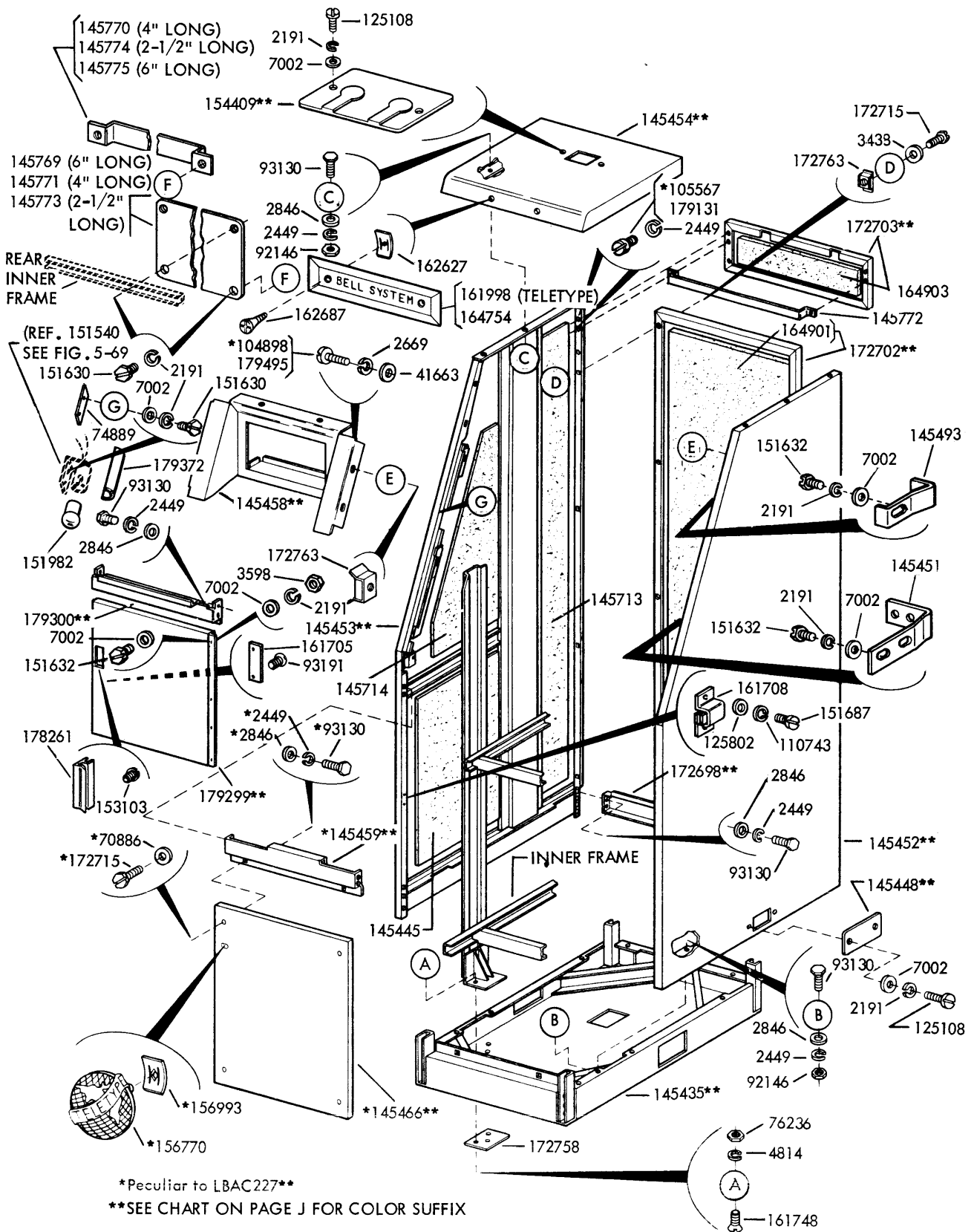
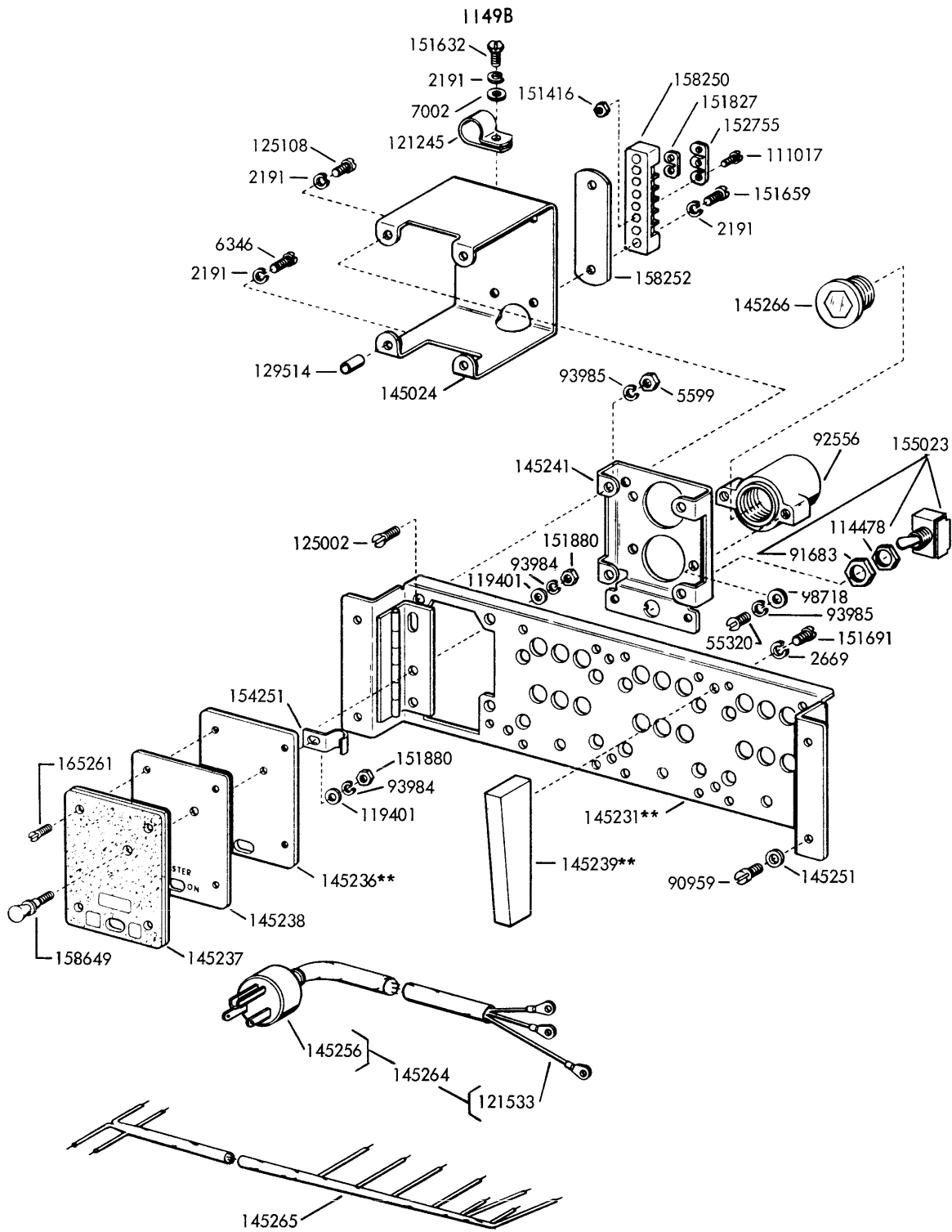


FIGURE 5-46. CABINET BODY ASSEMBLY (LBAC227\*\* AND LBAC233\*\*)





\*\* SEE CHART ON PAGE J FOR COLOR SUFFIX

FIGURE 5-47. PANEL MOUNTING ASSEMBLY (LBAC227\*\*)

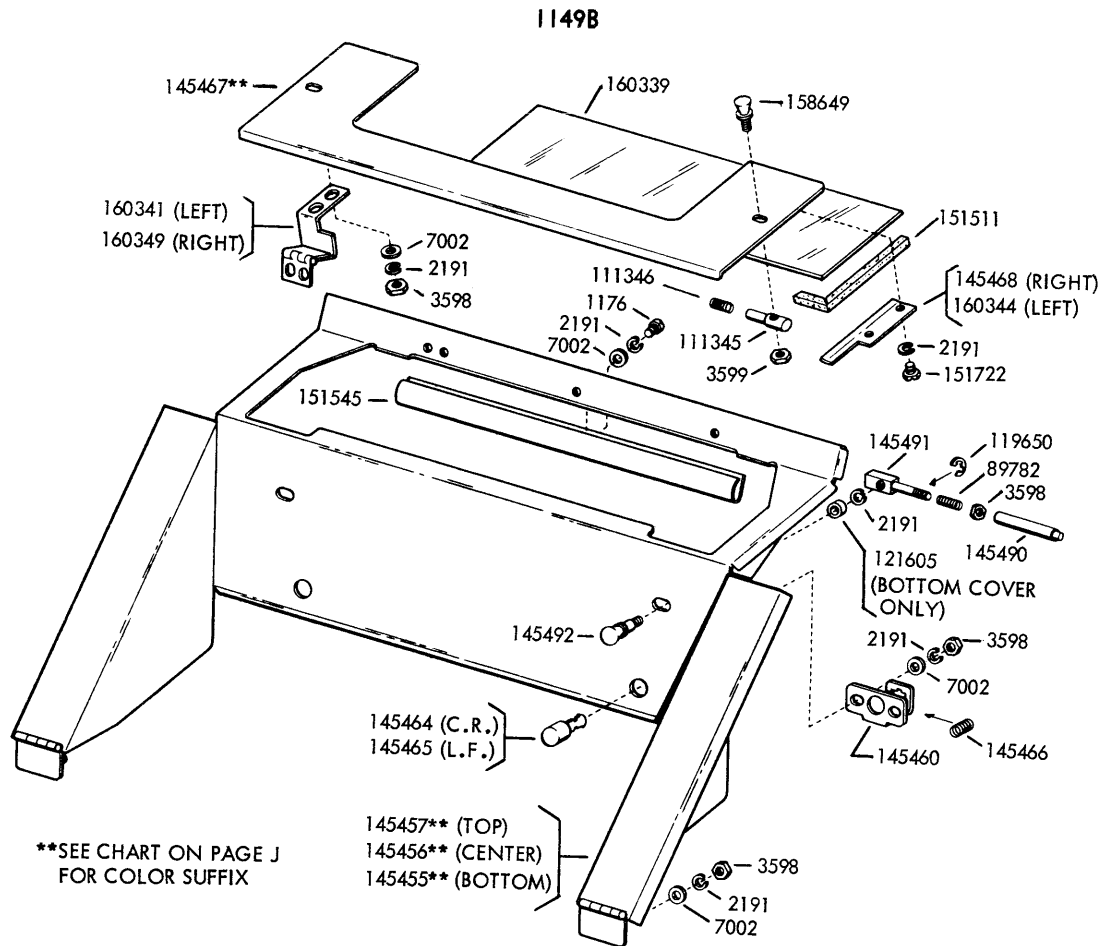
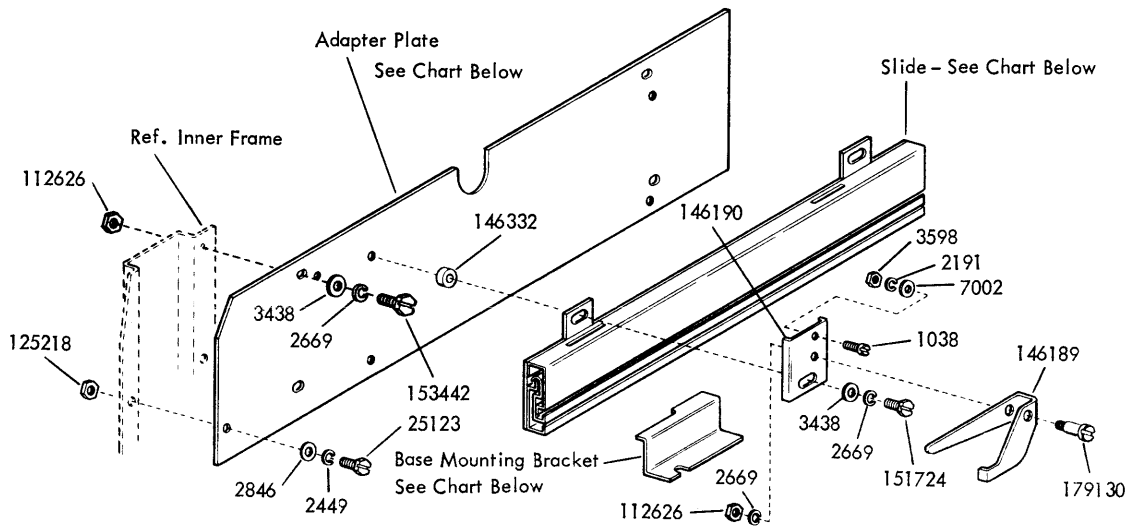


FIGURE 5-48. COVER ASSEMBLY (LBAC227\*\*)



Description	Location					
	Top		Center		Bottom	
	Left	Right	Left	Right	Left	Right
Adapter Plate	146171	146171	146173	145173	146179	146179
Slide	146187	145188	146185	146186	146185	146186
Base Mounting Bracket	Front	145164	146163	146170	146169	179297
	Rear	146166	146165	146168	146167	

FIGURE 5-49. SLIDE ASSEMBLIES (LBAC228\*\* AND LBAC233\*\*)

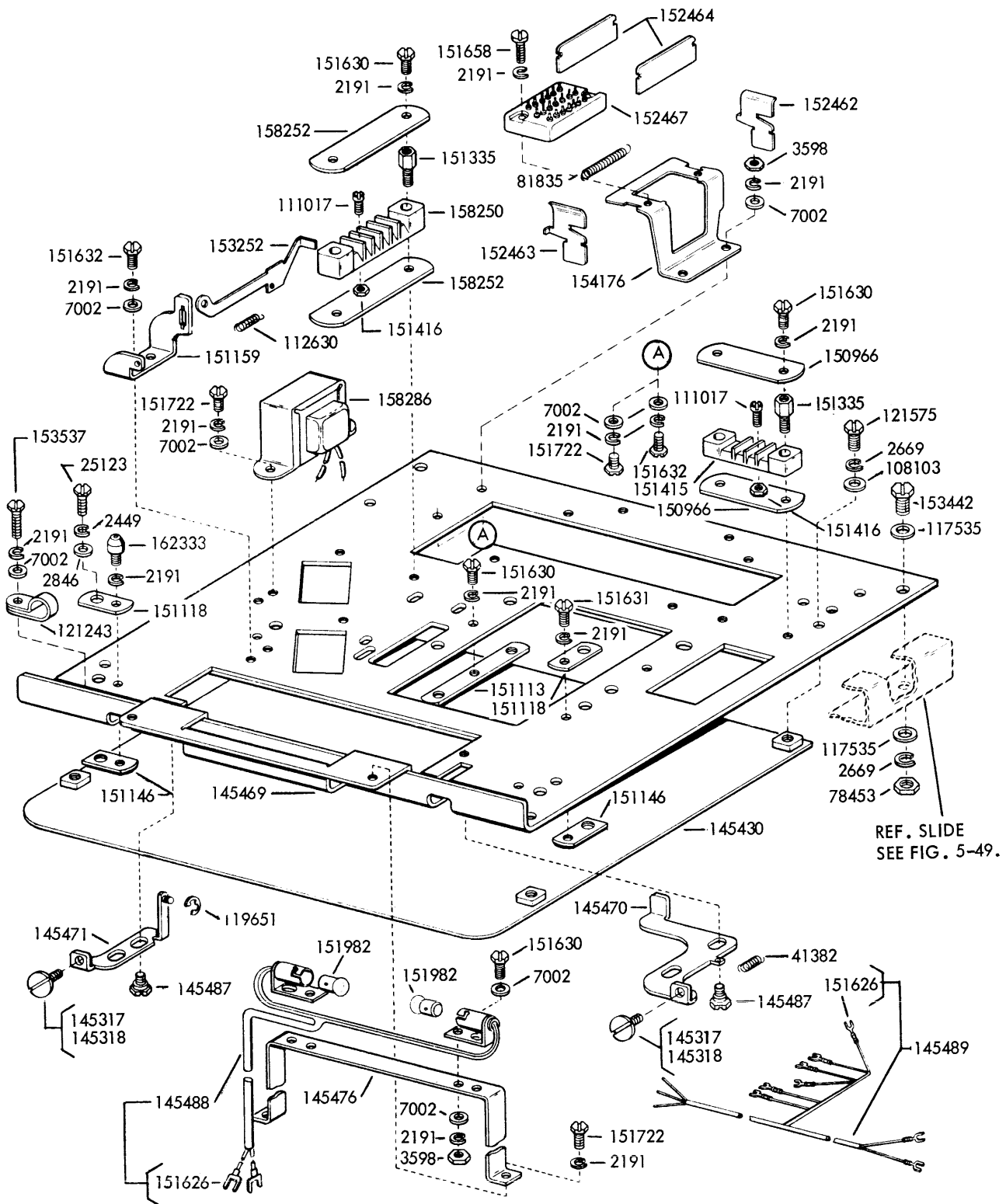
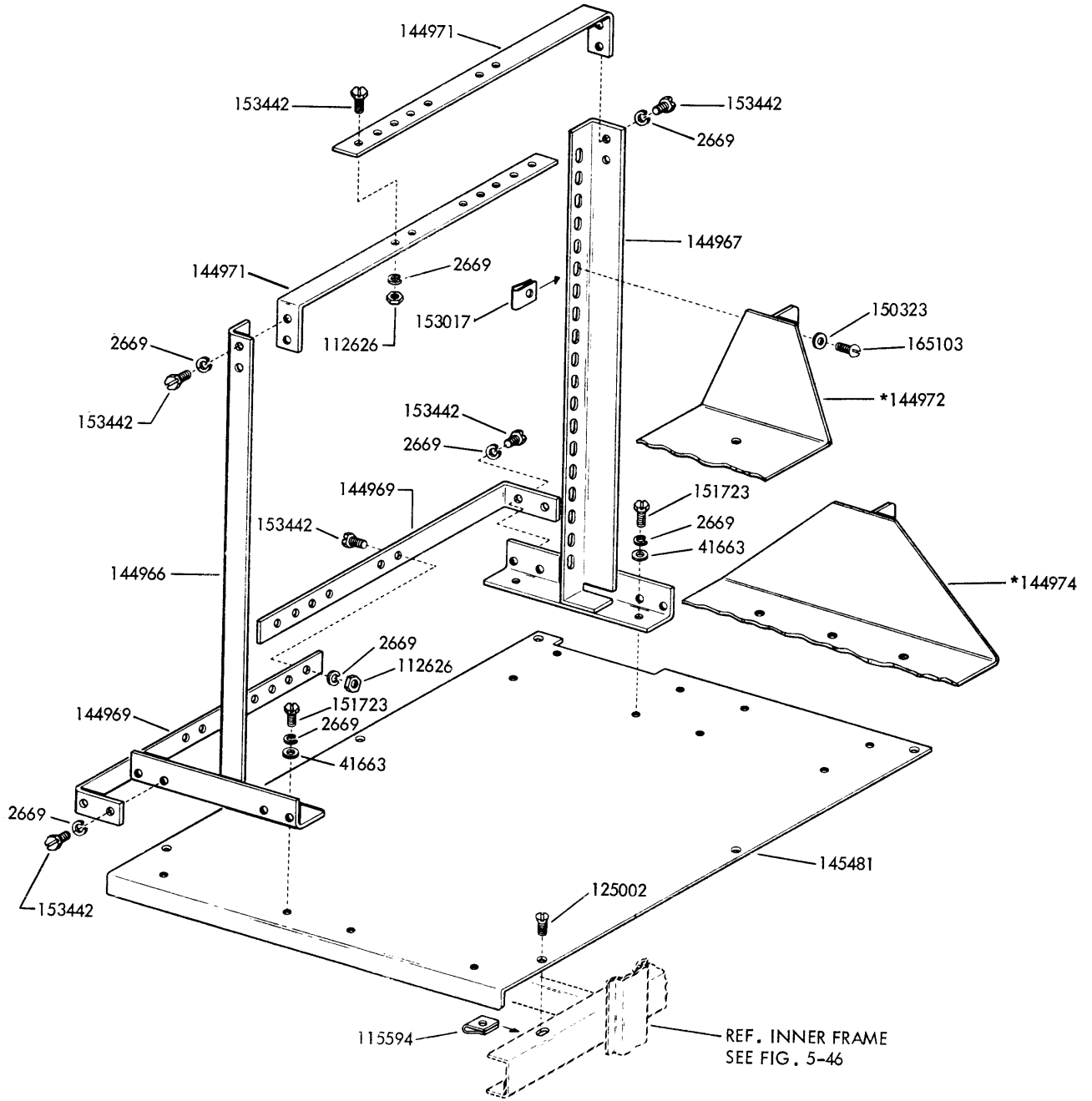
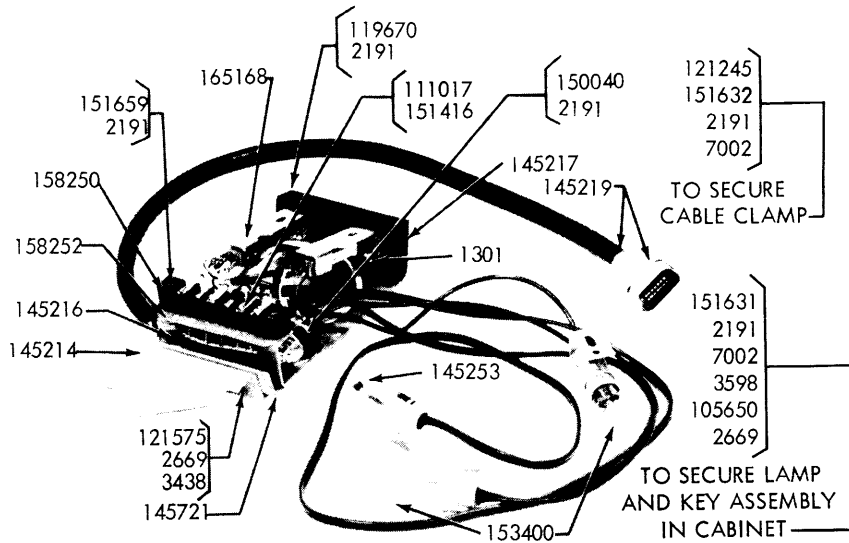


FIGURE 5-50. BASE PLATE ASSEMBLY (LBAC227\*\*)



\*Peculiar to LBAC227\*\*

FIGURE 5-51. MOUNTING RACK ASSEMBLY (LBAC227\*\*) AND (LBAC233\*\*)



MODIFICATION KIT TO PROVIDE  
KEY AND LAMP ASSEMBLY

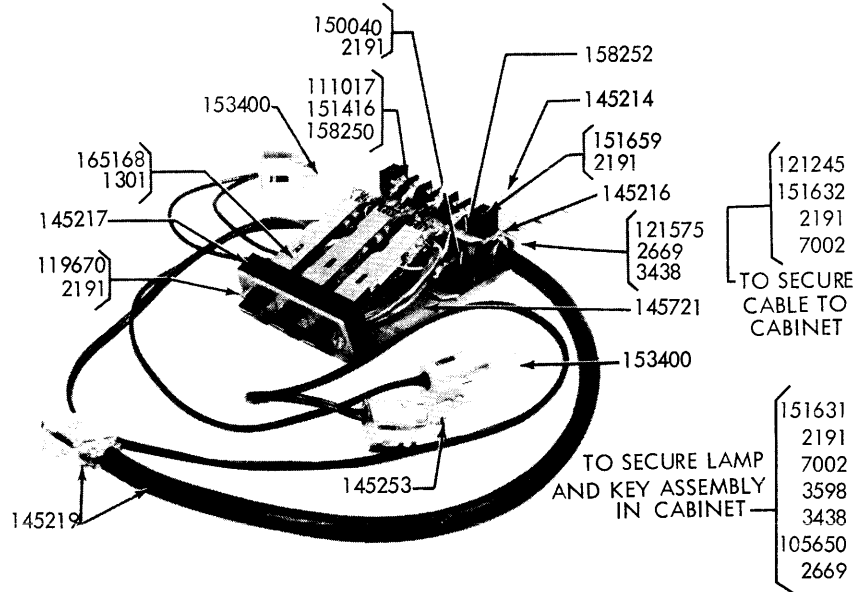
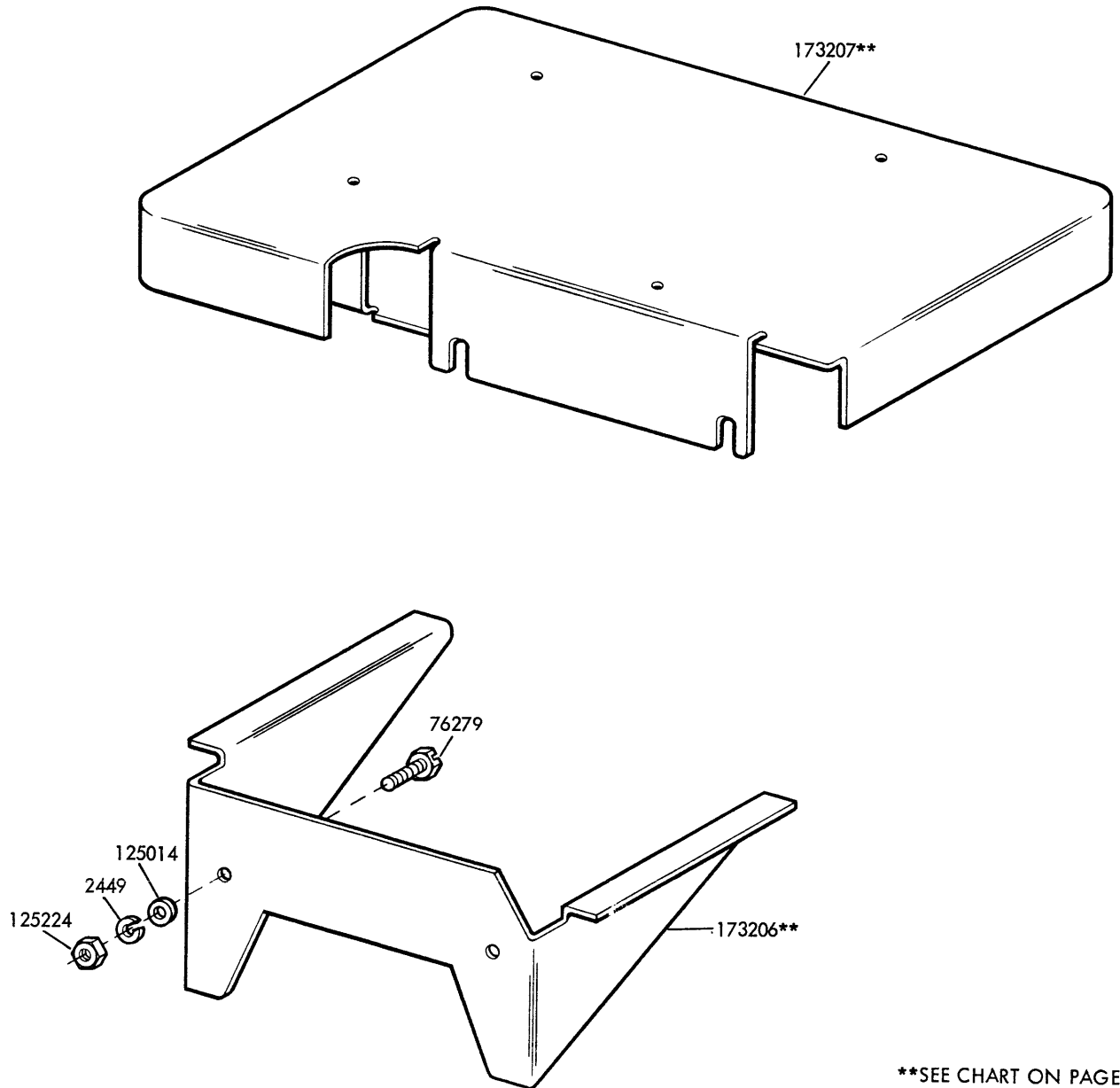
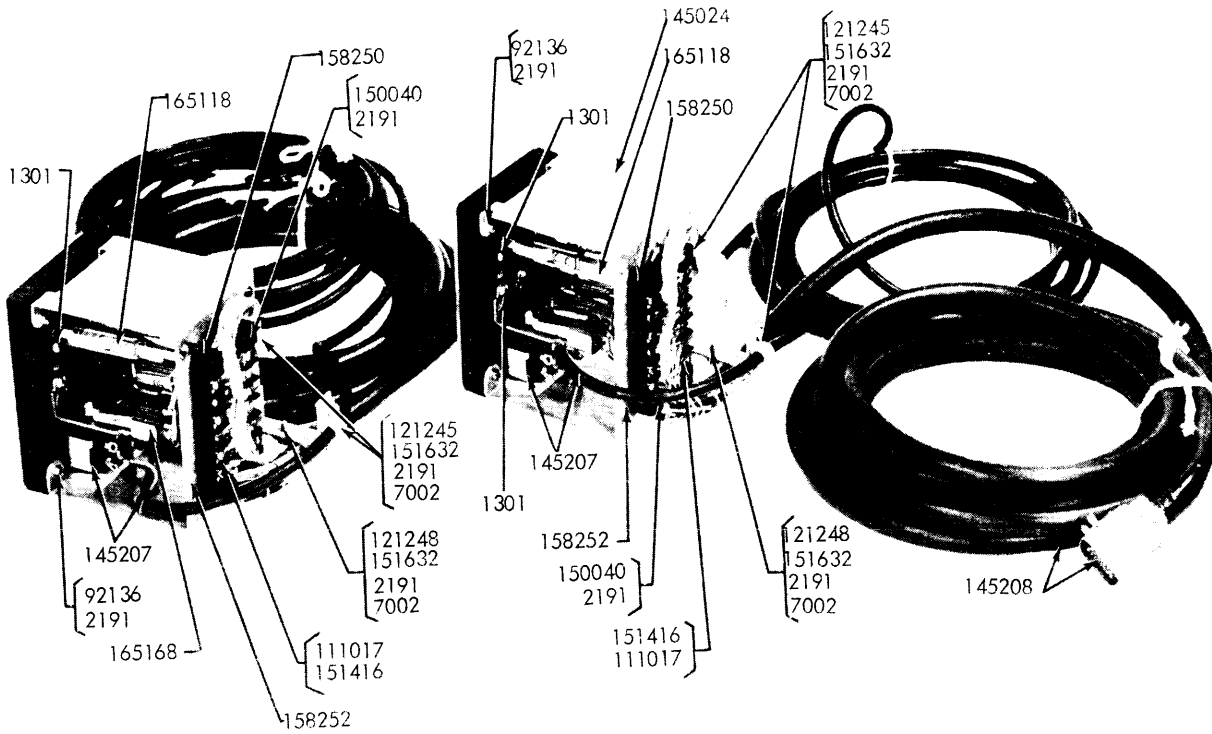


FIGURE 5-53. 144600 MODIFICATION KIT TO PROVIDE  
KEY AND LAMP ASSEMBLY



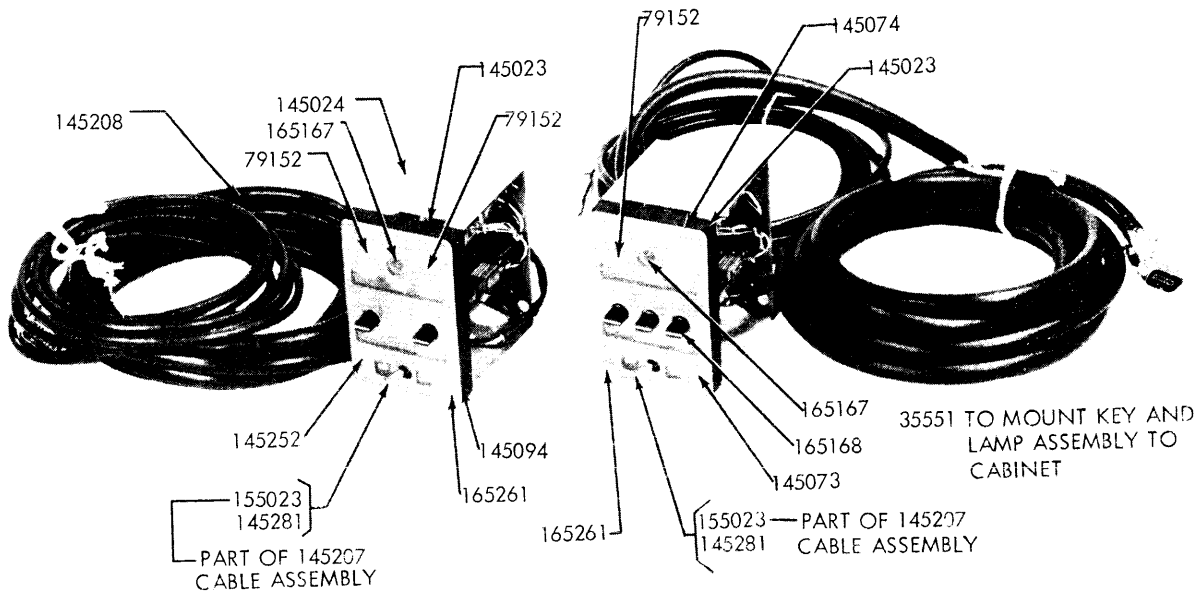
\*\*SEE CHART ON PAGE J  
FOR COLOR SUFFIX

FIGURE 5-54. 173097\*\* MODIFICATION KIT TO PROVIDE SHELF FOR CONSOLE CABINET



REAR VIEW

REAR VIEW



FRONT VIEW

FRONT VIEW

FIGURE 5-55. 145450 MODIFICATION KIT TO PROVIDE KEY AND LAMP ASSEMBLY

FIGURE 5-56. 145010 MODIFICATION KIT TO PROVIDE KEY AND LAMP ASSEMBLY

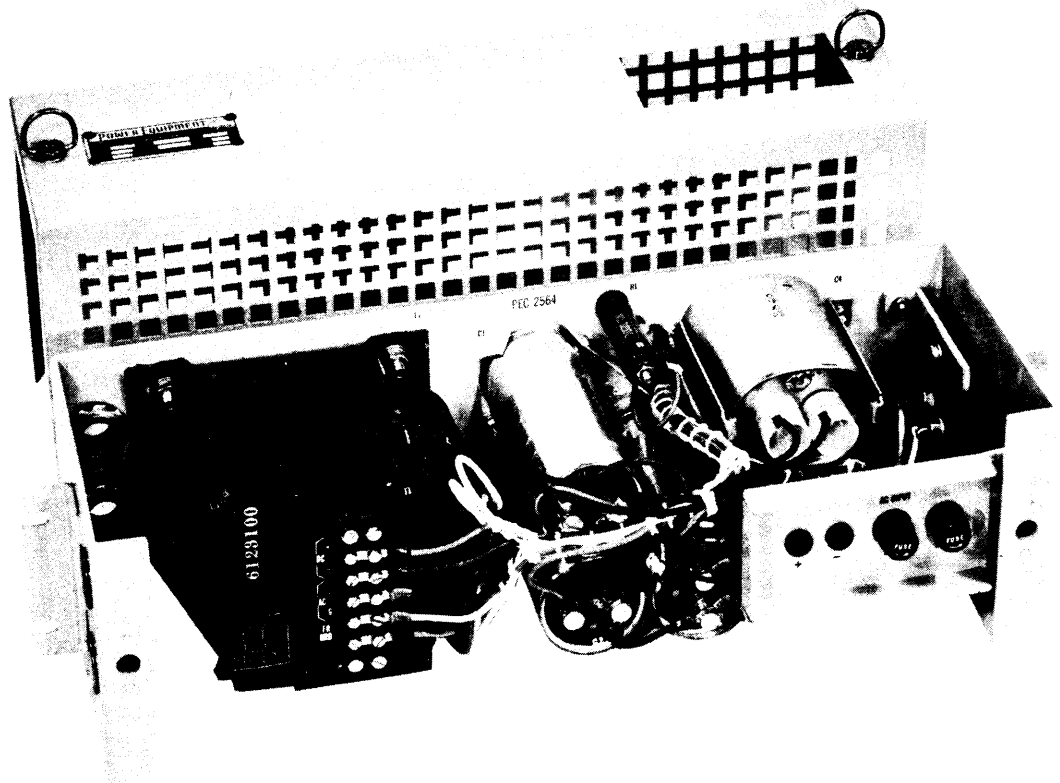


FIGURE 5-57. 145017 RECTIFIER - 48 VOLTS D.C.



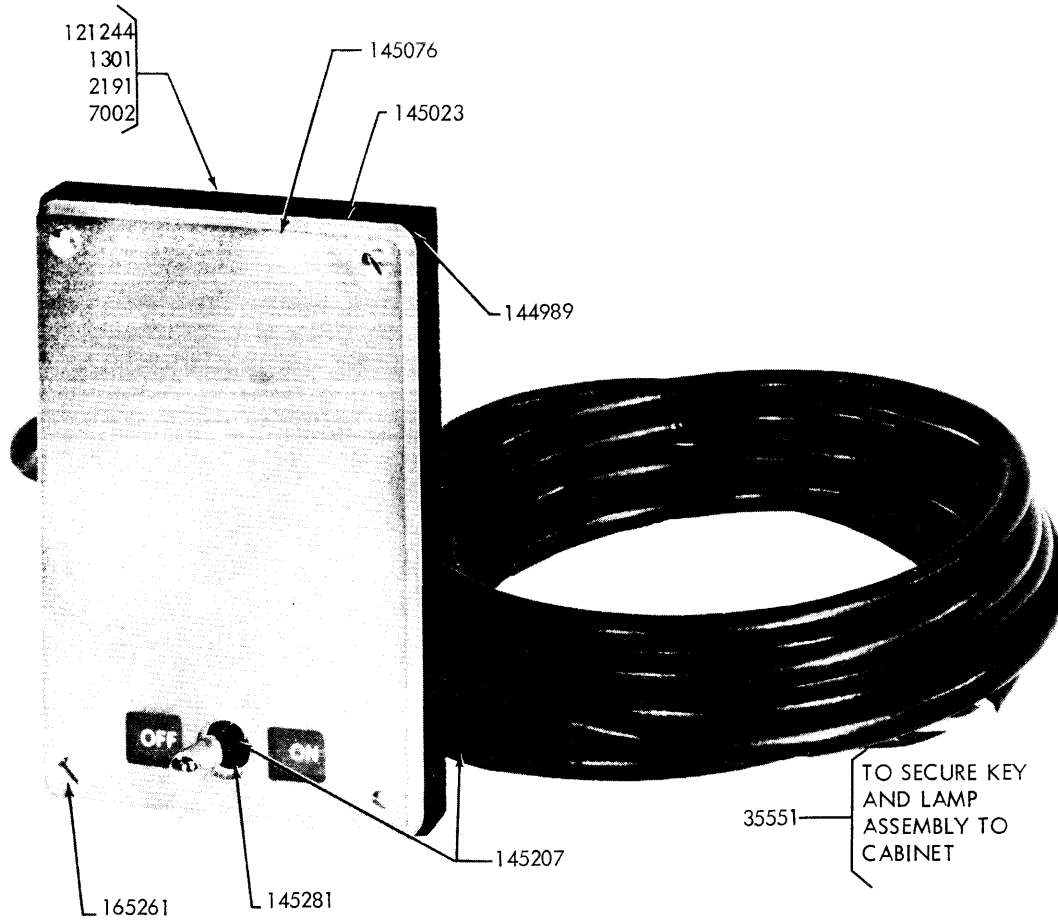


FIGURE 5-58. 145075 MODIFICATION KIT TO PROVIDE KEY AND LAMP ASSEMBLY

1149B

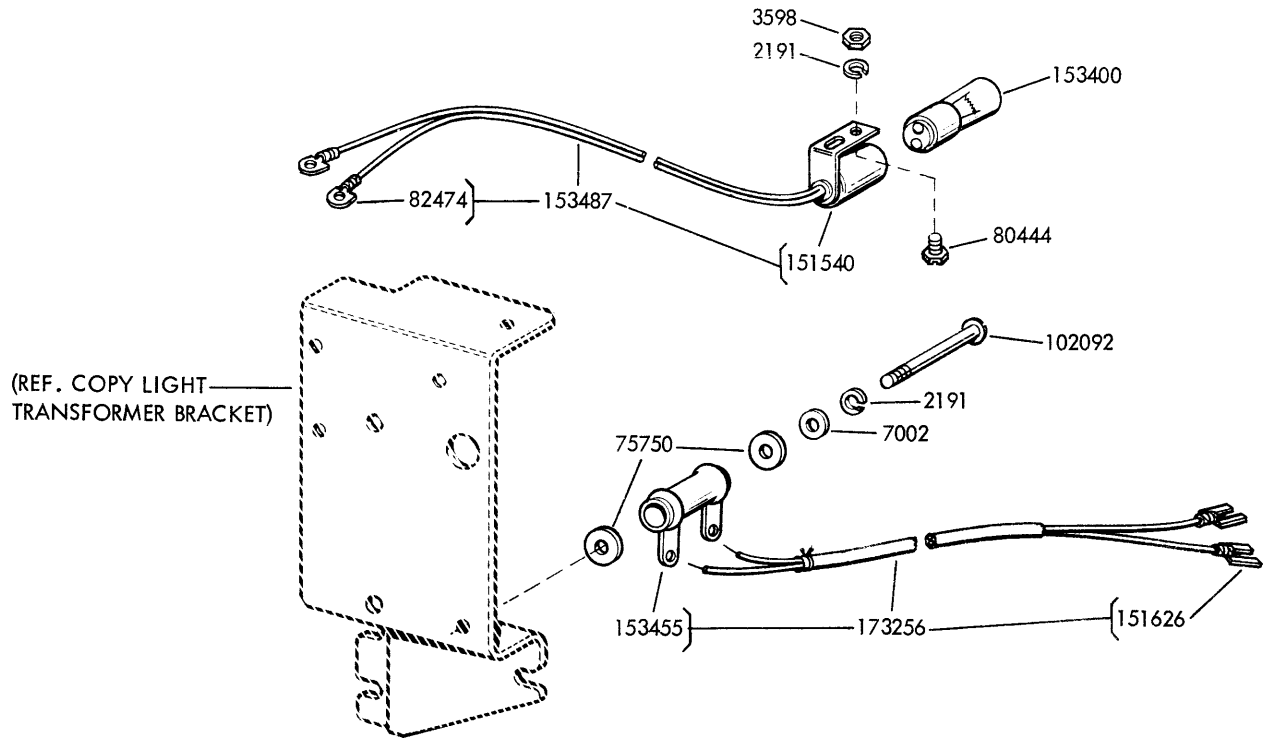


FIGURE 5-59. 173238 MODIFICATION KIT TO ADD READY LIGHT TO LAC CABINET

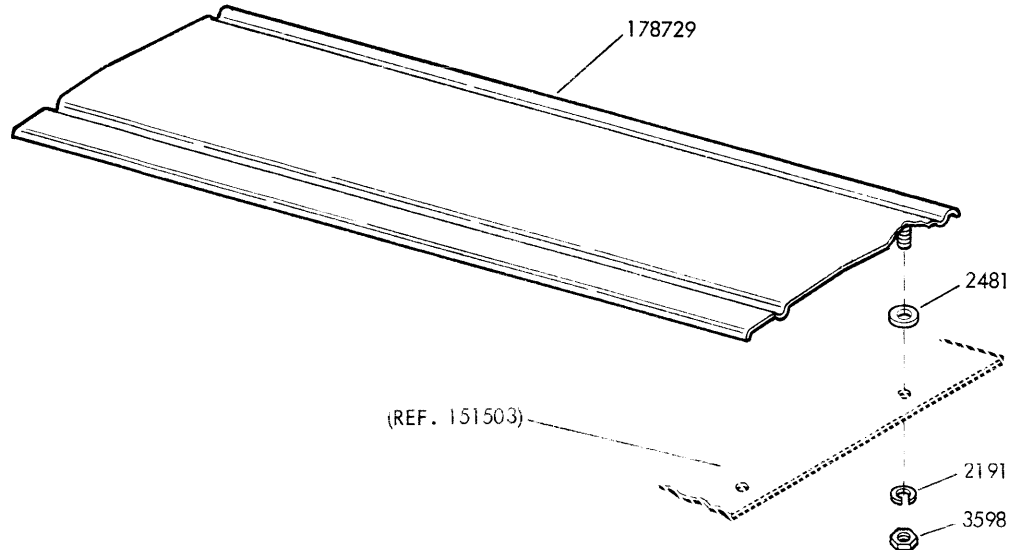


FIGURE 5-60. 174458 MODIFICATION KIT TO PROVIDE LAC CABINET WITH A PAPER TEARING PLATE

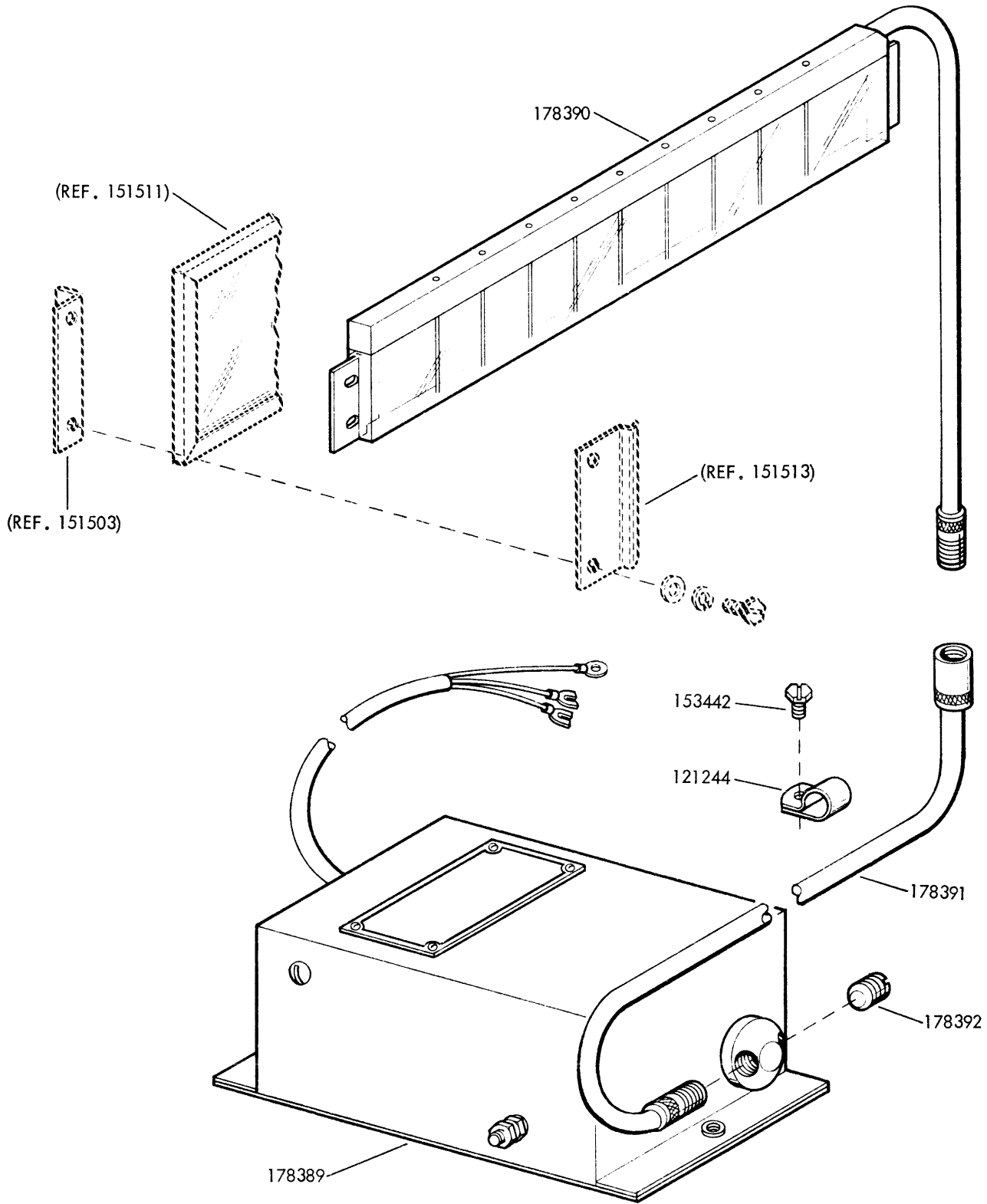
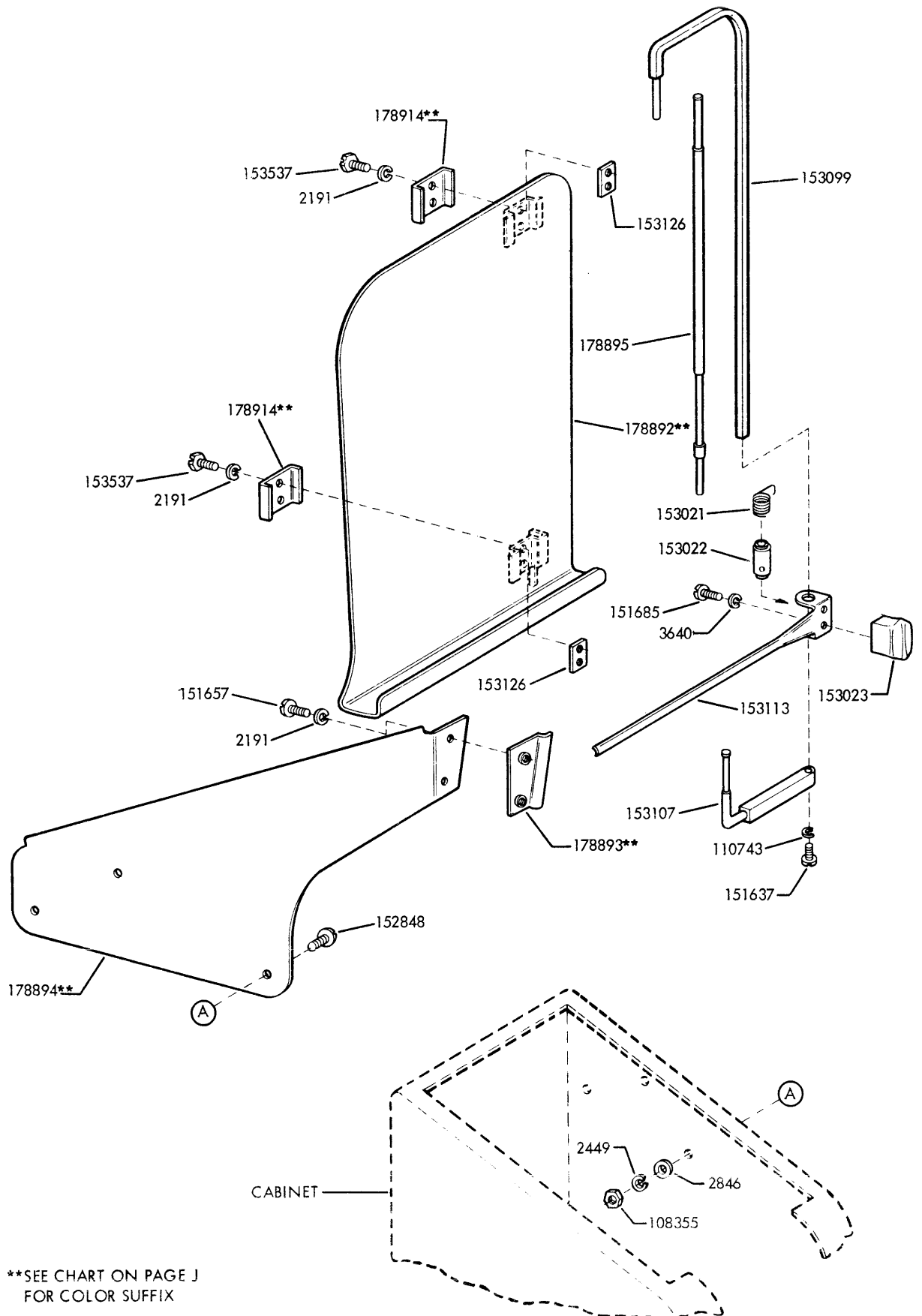


FIGURE 5-61. 178387 MODIFICATION KIT TO PROVIDE HIGH VOLTAGE STATIC ELIMINATOR TO NEUTRALIZE ELECTROSTATIC CHARGE ON PAGE COPY



\*\*SEE CHART ON PAGE J  
FOR COLOR SUFFIX

FIGURE 5-62. 178897\*\* MODIFICATION KIT TO PROVIDE OFFSET COPYHOLDER

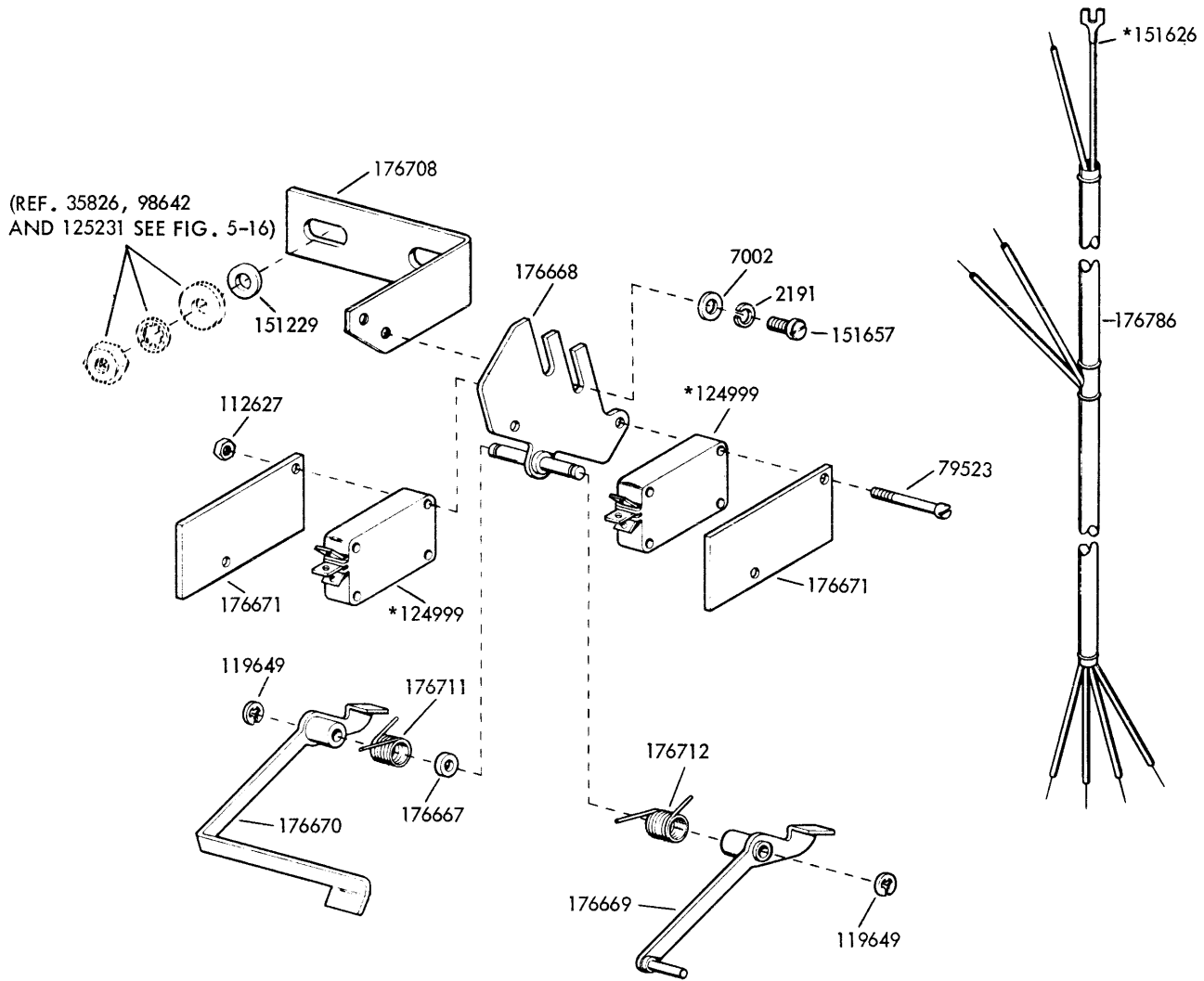
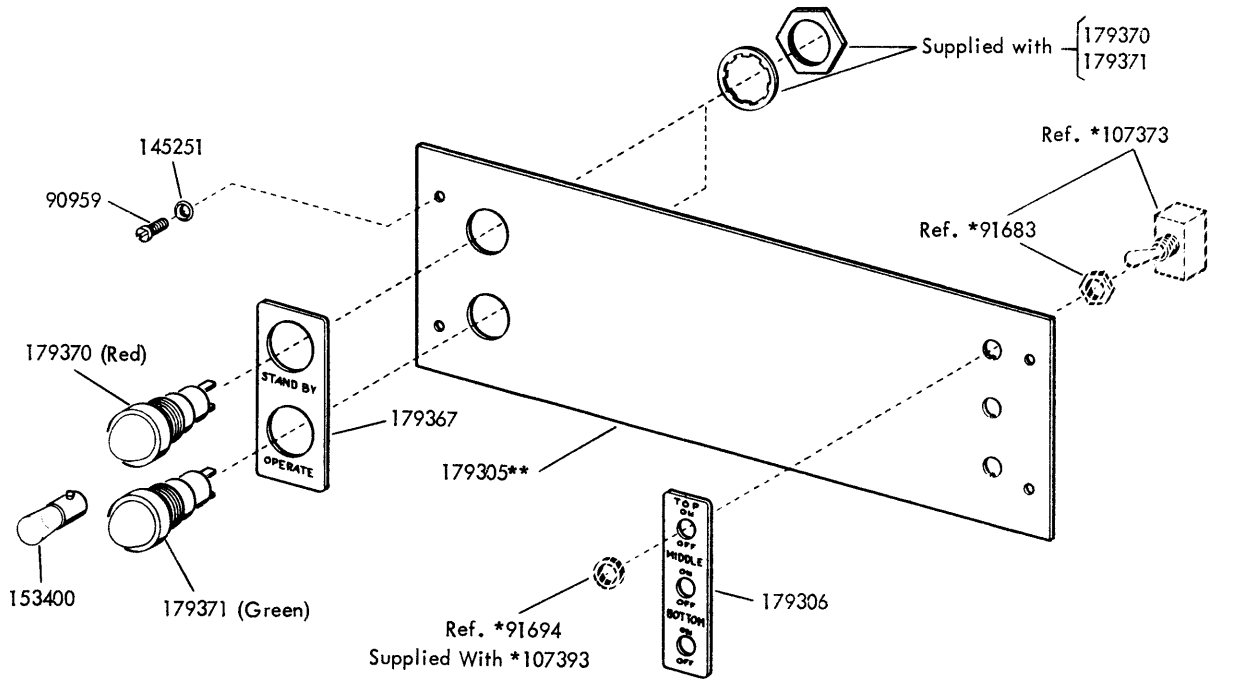


FIGURE 5-63. 176714 MODIFICATION KIT TO PROVIDE LOW PAPER AND PAPER OUT ALARM



\*Part of 179375 Cable Assembly  
See Fig. 5-70

FIGURE 5-64. CONTROL PANEL ASSEMBLY (LBAC233\*\*)

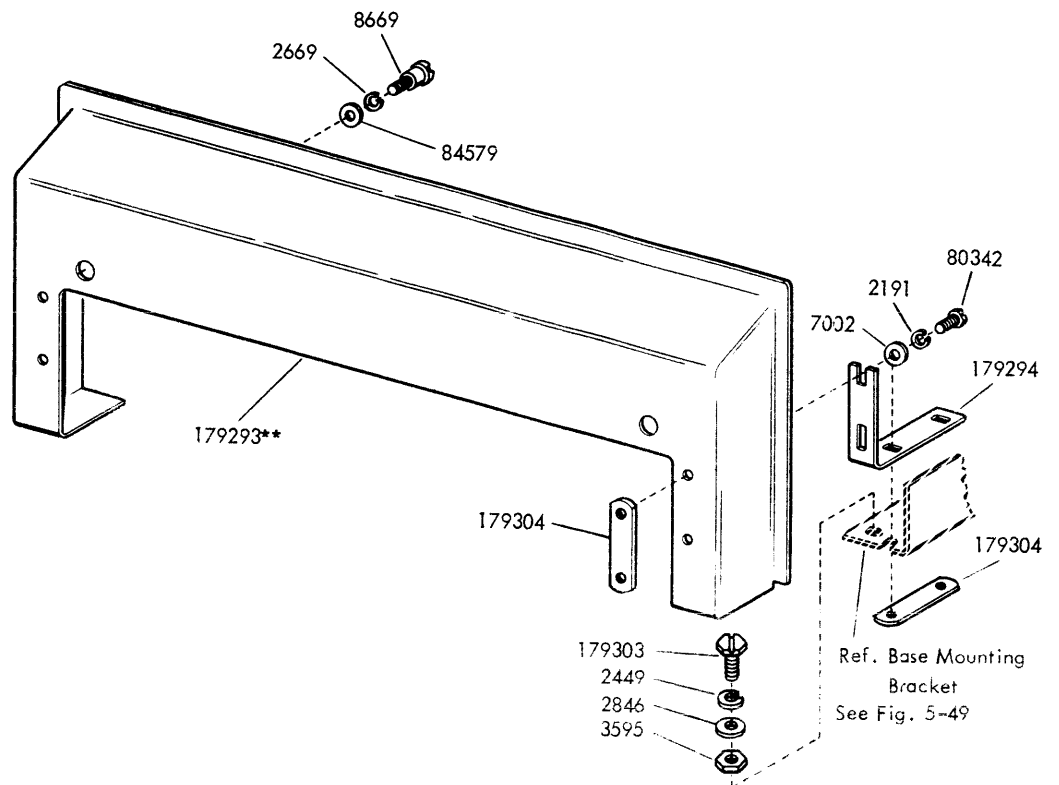


FIGURE 5-65. KEYBOARD PANEL ASSEMBLY (LBAC233\*\*)

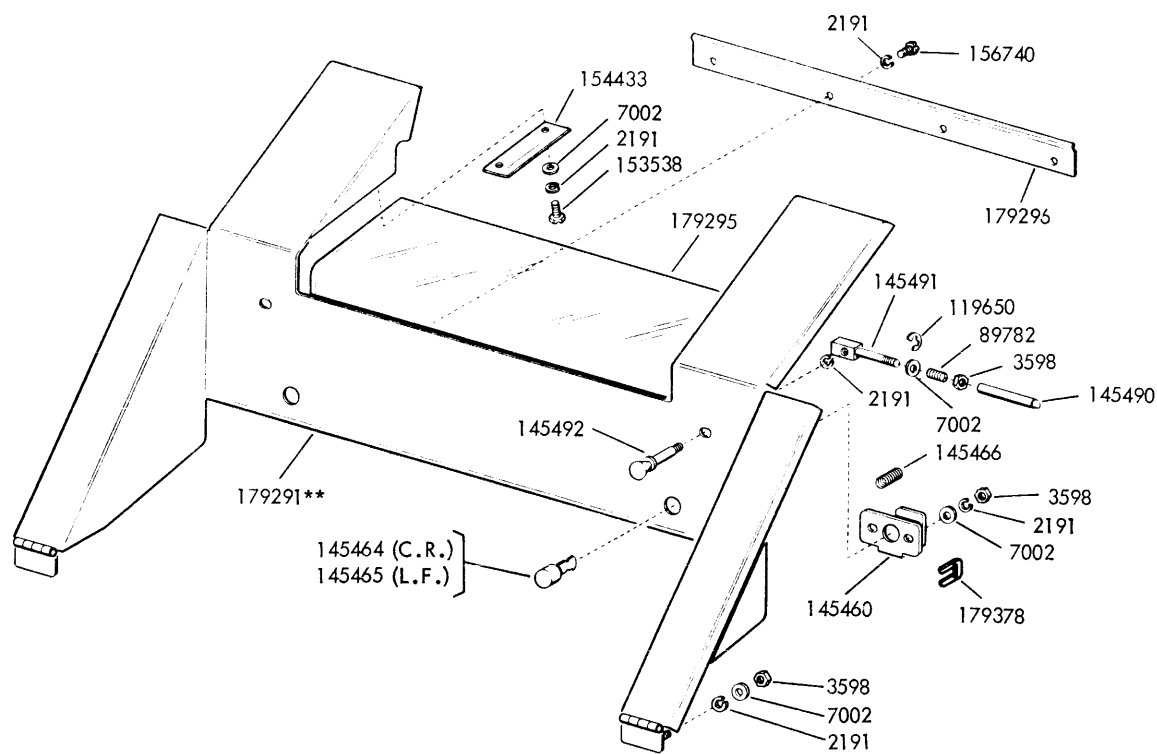


FIGURE 5-66. TOP AND MIDDLE COVER ASSEMBLIES (LBAC233\*\*)

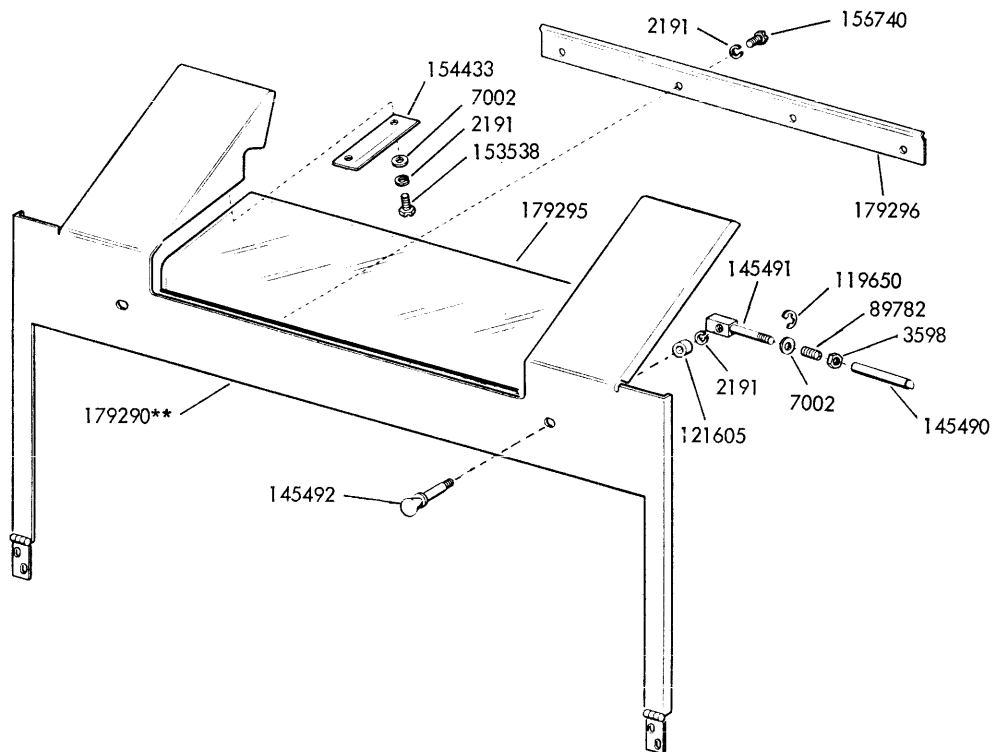


FIGURE 5-67. BOTTOM COVER ASSEMBLY (LBAC233\*)

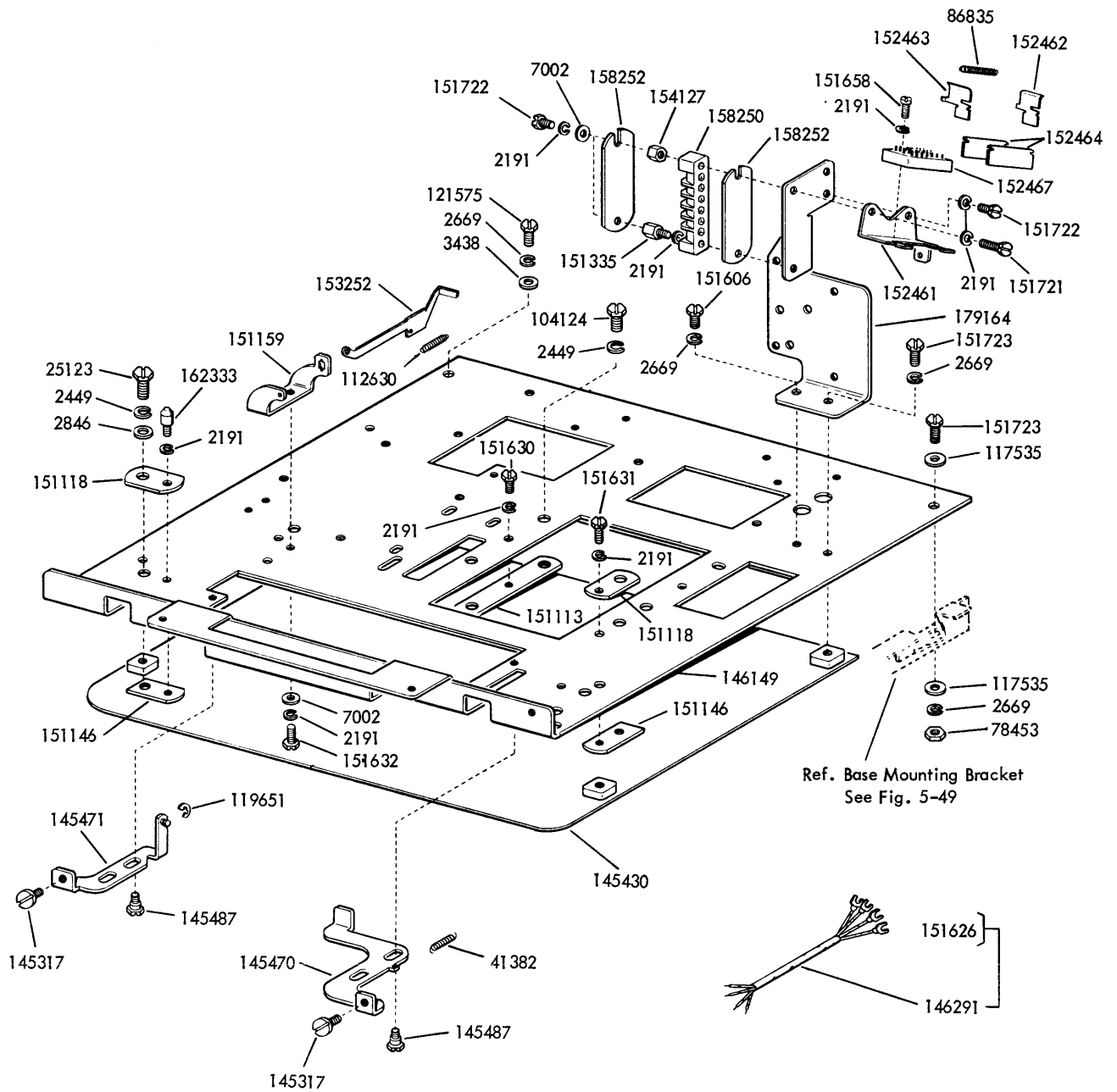
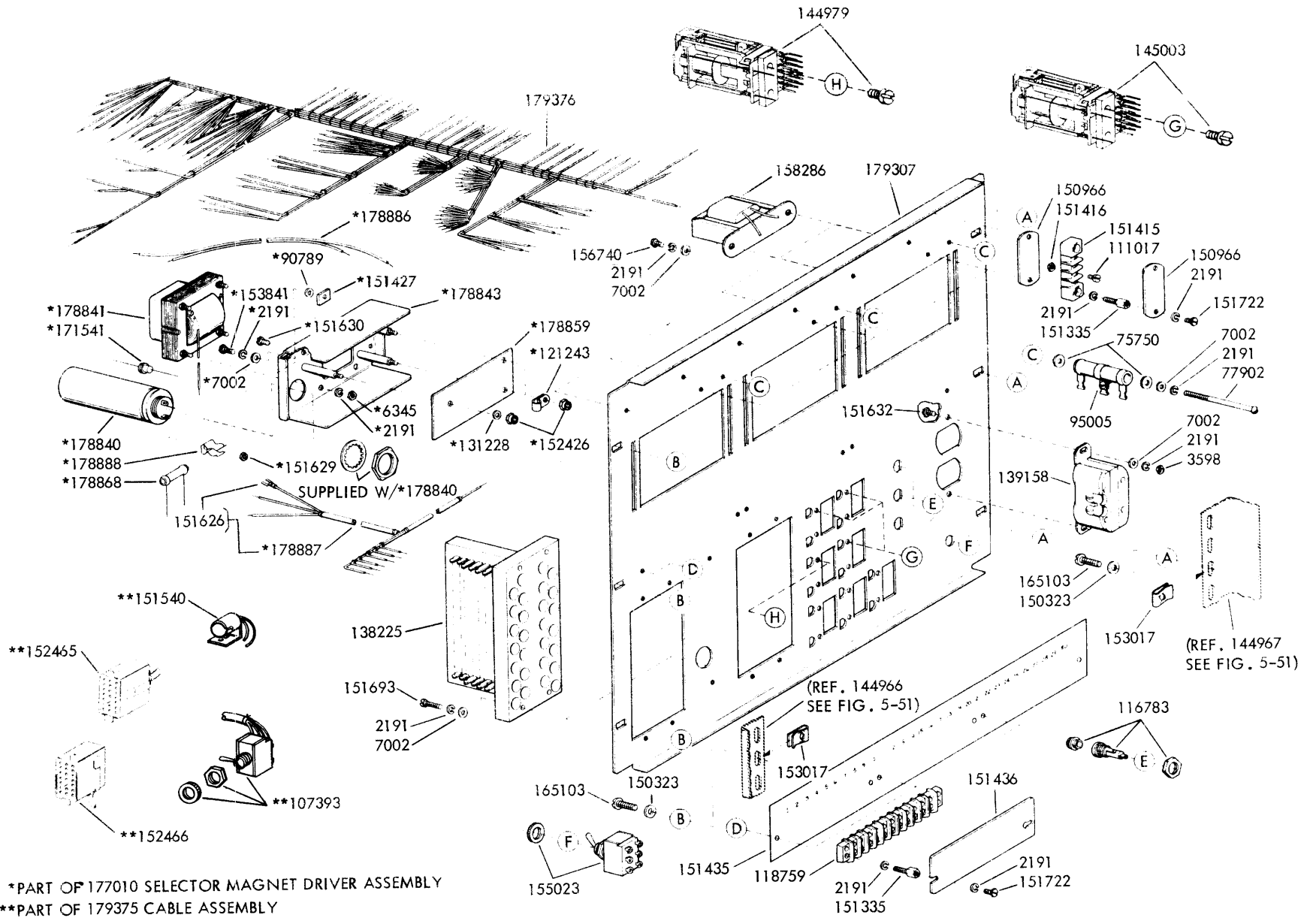


FIGURE 5-68. BASE PLATE ASSEMBLY (LBAC233\*\*)



FIGURE 5-69. ELECTRICAL SERVICE ASSEMBLY (LBAC233\*\*)



## NUMERICAL INDEX - SECTION 5

Part Number	Description and Page Number	Part Number	Description and Page Number	Part Number	Description and Page Number
247M	Coil, Magnet 5-3,5-4,5-15,5-29	49644	Screw, Shoulder (10-32) 5-27,5-30	92687	Washer, Flat 5-5
1028	Screw (4-40 x 1/4 Fil) 5-3,5-4,5-15	55219	Screw (8-32 x 5/8 Fil) 5-3,5-4,5-15,5-29	93108	Washer, Lock 5-3,5-4,5-8,5-15
1038	Screw (6-40 x 9/32 Fil) 5-41	55320	Screw (8-32 x 7/16 Rd) 5-40	93118	Washer, Lock 5-17
1079	Screw (6-32 x 5/16 Rd) 5-49	70314	Washer, Flat 5-20,5-21	93130	Screw (1/4-20 x 1/2 Hex) 5-33,5-34,5-39,5-41
1113	Screw (1/4-20 x 7/8 Hex) 5-3,5-4,5-15	70593	Screw, Thumb (6-40) 5-28,5-32	93191	Screw (4-40 x 5/16 Flat) 5-39
1118	Screw, Shoulder (6-40) 5-37	70866	Washer, Flat 5-39	93984	Washer, Lock 5-40
1176	Screw (6-40 x 3/16 Fil) 5-41	71858	Washer, Flat 5-3,5-4,5-15	93985	Washer, Lock 5-40
1178	Screw (2-56 x 7/16 Fil) 5-17	72565	Washer, Lock 5-26	94660	Connector, 90° 5-32
1248	Screw (6-40 x 7/16 Flat) 5-35	72787	Washer, Lock 5-33	95005	Resistor (2500 Ohm) 5-56
1263	Screw (6-32 x 1/4 Fil) 5-15	73752	Screw (1/4-20 x 1 Hex) 5-36	95281	Screw (10-24 x 3/8 Fil) 5-34,5-36
1264	Screw (10-32 x 1/2 Flat) 5-34	74011	Screw, Shoulder (6-40) 5-15	95320	Switch, Toggle 5-26
1268	Screw (6-40 x 5/16 Flat) 5-11	74479	Bushina 5-3,5-25	96258BK	Wire, (3 <sup>rd</sup> Black) 5-21
1301	Screw (6-32 x 3/8 Rd) 5-44,5-46,5-48	74546	Clamp, Cable 5-2,5-14	97393	Screw, Shoulder (6-40) 5-25
2191	Washer, Lock (Sev.)	74567	Screw (1/4-20 x 33/64 Hex) 5-3,5-4,5-14,5-15	97492	Nut (10-24 Hex) 5-34,5-36
2322	Washer, Lock 5-26	74594	Rina, Retaining 5-2	98544	Connector, Plug (4 Pt.) 5-28
2449	Washer, Lock 5-3,5-6,5-7,5-8,5-14,5-15,5-23,5-28,5-29,5-31,5-39,5-41,5-42,5-45,5-51,5-53,5-55	74712	Sprina 5-2,5-14	98642	Washer, Lock 5-2,5-7,5-8,5-14
2481	Washer, Flat 5-49	74889	Block 5-39	98718	Washer, Flat 5-40
2539	Nut (3/8-32 Hex) 5-2	75750	Washer, Fiber 5-49,5-56	100184	Screw 10-32 x 13/32 Fil) 5-15
2669	Washer, Lock 5-26,5-30,5-33,5-34,5-36,5-39,5-40,5-41,5-42,5-43,5-44,5-53	76099	Washer, Flat 5-2,5-3,5-14	100873	Screw, Shoulder (6-40) 5-5
2846	Washer, Flat 5-3,5-4,5-6,5-7,5-8,5-14,5-15,5-23,5-29,5-39,5-41,5-42,5-51,5-53,5-55	76236	Nut (5/16-18 Hex) 5-33,5-39	101833	Screw (8-32 x 5/16 Rd) 5-35
2920	Washer, Lock 5-18	76279	Screw (1/4-32 x 5/8 Hex) 5-45	102092	Screw (6-40 x 1-17/32 Fil) 5-49
3226	Washer, Flat 5-23	76845	Screw (10-32 x 1/2 Rd) 5-34	102180	Screw (6-40 x 1-15/16 Fil) 5-9,5-28
3438	Washer, Flat 5-2,5-3,5-4,5-7,5-8,5-14,5-15,5-29,5-33,5-39,5-41,5-44	77902	Screw (6-40 x 2-3/8 Rd) 5-56	102617	Lamp, Fluorescent 5-3
3595	Nut (1/4-32 Hex) 5-29,5-53	78103	Screw (6-40 x 1-3/16 Fil) 5-2	102620	Switch, Starter 5-3
3598	Nut (6-40 Hex) (Sev.)	78287	Collar, Spacina 5-3	102751	Nut (10-32 Hex) 5-15
3599	Nut (4-40 Hex) 5-28,5-33,5-41	78301	Screw (10-32 x 5/8 Hex) 5-35	103092	Connector, Cord 5-2
3606	Nut (6-40 Hex) 5-25	78453	Nut (10-32 Hex) 5-42	103120	Nut, Speed 5-14
3639	Washer, Lock 5-2,5-3,5-4,5-12,5-13,5-14,5-15,5-17,5-20	78469	Foot, Rubber 5-6	103241	Block, Terminal 5-35
3640	Washer, Lock 5-3,5-4,5-8,5-14,5-25,5-27,5-28,5-29,5-30,5-51	78766	Screw, Hinae Mta. 5-29	103355	Screw (1/4-20 x 3/8 Rd) 5-33
3646	Washer, Lock 5-3,5-4,5-15,5-29	79152	Lamp 5-46	103612	Nut (3/8-16 Hex) 5-18
4703	Sprina 5-3,5-4,5-15,5-29	79523	Screw (2-56 x 25/32 Fil) 5-52	104124	Screw (1/4-32 x 11/32 Hex) 5-55
4814	Washer, Lock 5-39	80342	Screw (6-40 x 23/64 Hex) 5-3,5-53	104701	Screw (4-40 x 7/32 Fil) 5-10
4851	Terminal 5-21	80444	Screw (6-40 x 1/4 Hex) 5-49	104898	Screw (10-24 x 5/8 Fil) 5-39
5599	Nut (8-32 Hex) 5-40	80481	Screw, Paper Guide (6-40) 5-7	105567	Screw (10-24 x 1/2 Fil) 5-39
5816	Washer, Fiber 5-9,5-26,5-28	80854	Screw (6-40 x 1-7/16 Fil) 5-20,5-21,5-26	105650	Screw (10-32 x 9/16 Hex) 5-44
6345	Nut (6-32 Hex) 5-2,5-11,5-14,5-57	81835	Washer, Flat 5-42	106047	Screw (1/4-32 x 1/2 Hex) 5-23
6346	Screw (6-32 x 51/64 Fil) 5-40	82474	Terminal 5-3,5-4,5-9,5-10,5-13,5-15,5-16,5-20,5-21,5-24,5-28,5-29,5-37,5-49	107116	Washer, Lock 5-3,5-15
6745	Screw (10-32 x 1/2 Hex) 5-26	82505	Screw (6-32 x 11/32 Fil) 5-8	107393	Switch, Toggle 5-33,5-53,5-56
7002	Washer, Flat (Sev.)	82832	Washer, Lock 5-33	107398	Terminal 5-24
7015	Strip, Screw 5-7	84579	Washer, Flat 5-2,5-14,5-27,5-30,5-53	108103	Washer, Flat 5-42
7415	Nut (1/2-32 Hex) 5-26	85529	Screw, Shoulder (10-32) 5-15	108355	Nut (1/4-20 Hex) 5-8,5-23,5-28,5-31,5-51
8330	Washer, Flat 5-30	85559	Washer, Flat 5-5	110434	Screw (4-40 x 3/16 Fil) 5-3,5-4,5-15,5-28,5-29
8333	Screw (10-32 x 3/8 Rd) 5-2,5-3,5-4,5-14,5-15	85609	Screw (1-40 x 5/8 Oval) 5-34	110435	Nut (4-40 Hex) 5-3,5-4,5-15
8669	Screw, Shoulder (6-40) 5-53	86329	Screw (6-40 x 7/16 Rd) 5-33	110437	Spring 5-3
25123	Screw (1/4-32 x 7/16 Hex) 5-41,5-42,5-55	86433	Screw (3/8-16 x 2 Hex) 5-18	110743	Washer, Lock 5-8,5-17,5-29,5-33,5-39,5-51
34432	Washer, Flat 5-15	86835	Sprina 5-37,5-55	111003	Connector, Receptacle (8 Pt.) 5-29
35503	Foot, Rubber 5-28,5-31,5-32	86968	Pin, Cotter 5-36	111017	Screw (6-40 x 1/4 Fil) 5-12,5-13,5-20,5-27,5-30,5-37,5-38,5-40,5-42,5-44,5-46,5-56
35551	Screw (10-32 x 9/32 Flat) 5-34,5-48	88456	Mount, Vibration 5-28,5-31	111345	Bolt, Latch 5-25,5-41
35555	Screw (10-32 x 3/8 Flat) 5-46	89305	Screw (1/4-20 x 3/4 Hex) 5-26	111346	Spring 5-41
35826	Washer, Flat 5-2,5-14	89515	Screw (6-32 x 9/32 Unslotted) 5-14	111347	Screw, Thumb (4-40) 5-25
41382	Sprina 5-42	89782	Sprina 5-41,5-54	111409	Screw (4-40 x 7/32 Fil) 5-6
41663	Washer, Flat 5-12,5-39,5-43	89969	Washer, Fiber 5-20,5-21	111516	Spacer 5-34,5-35,5-37,5-38
43954	Bell, Signal 5-3,5-4,5-15,5-29	90096	Washer, Fiber 5-13	111776	Connector, Plug (4 Pt.) 5-30
45815	Washer, Lock 5-29,5-34,5-35,5-37,5-38	90599	Shim (.008) 5-8	111777	Connector, Receptacle (4 Pt.) 5-30
49514	Nut (8-32 Hex) 5-22	90789	Washer, Flat 5-56	112626	Nut (10-32 Hex) 5-26,5-27,5-30,5-34,5-41,5-43
		90814	Resistor (1000 Ohms) 5-9,5-10,5-28	112627	Nut (2-56 Hex) 5-52
		90959	Screw (6-32 x 3/4 Oval) 5-40,5-53	112630	Spring 5-42
		91683	Nut (15/32-32) 5-4,5-13,5-20,5-40,5-53	113099	Screw, Thumb (6-40) 5-37
		92136	Screw (6-32 x 3/8 Fil) 5-46	114478	Nut (15/32-32 Hex) 5-40
		92146	Nut (1/4-20) 5-33,5-34,5-36,5-39,5-41	114589	Mount, Vibration 5-3,5-4,5-15
		92260	Washer, Lock 5-29	115594	Nut, Speed 5-43
		92527	Washer, Lock 5-22	116082	Screw, Shoulder (1/4-32) 5-29
		92556	Receptacle 5-40	116783	Holder, Fuse 5-37,5-38,5-56
				117535	Washer, Flat 5-42

## 1149B

## NUMERICAL INDEX - SECTION 5 (Continued)

Part Number	Description and Page Number	Part Number	Description and Page Number	Part Number	Description and Page Number
117878	Strap 5-21	145003	Relay 5-56	145492	Screw, Thumb 5-54
118118	Reactor, Ballast 5-3	145010	Modification Kit 5-46	145493	Plate, Striker 5-39
118119	Block, Terminal 5-2	145017	Rectifier (48 V. DC) 5-47	145713	Pad, Felt 5-39
118759	Block, Terminal 5-2,5-56	145023	Panel, Rubber 5-46,5-48	145714	Pad, Felt 5-39
119389	Washer, Flat 5-28	145024	Shield Assembly 5-40,5-46	145721	Bracket, Mountina 5-44
119401	Washer, Flat 5-40	145047	Connector, Plua 5-24	145769	Plate 5-39
119638**	Button, Plug 5-2	145065	Cable Assembly (T) 5-24	145770	Bracket 5-39
119641**	Button, Plug 5-2	145073	Panel, Plastic 5-46	145771	Plate 5-39
119467	Insulator 5-17	145074	Plate, Desianation 5-46	145772	Bracket 5-39
119649	Ring, Retaining 5-52	145075	Modification Kit 5-48	145773	Plate 5-39
119650	Ring, Retaining 5-41,5-54	145076	Panel, Plastic 5-48	145774	Bracket 5-39
119651	Ring, Retaining 5-42	145077**	Cabinet 5-2	145775	Bracket 5-39
119655	Ring, Retaining 5-26	145094	Plate, Desianation 5-46	146163	Bracket, Right Top 5-41
119670	Screw (6-32 x 1/2 Fil) 5-44	145207	Cable Assembly 5-46,5-48	146164	Bracket, Left Top 5-41
121125	Washer, Spring 5-26	145208	Cable Assembly 5-46	146165	Bracket, Right Top 5-41
121242	Clamp, Cable (I.D. 1/8) 5-13,5-37	145214	Bracket 5-44	146166	Bracket, Left Top 5-41
121243	Clamp, Cable (I.D. 3/16) 5-3,5-10,5-12,5-13,5-20,5-27,5-30,5-42,5-56	145216	Bracket, Terminal 5-44	146167	Bracket, Right Middle 5-41
121244	Clamp, Cable (I.D. 1/4) 5-3,5-10,5-20,5-27,5-29,5-30,5-48,5-50	145217	Block, Mountina 5-44	146168	Bracket, Left Middle 5-41
121245	Clamp, Cable (I.D. 5/16) 5-4,5-10,5-12,5-13,5-20,5-40,5-44,5-46	145219	Cable Assembly 5-44	146169	Bracket, Right Middle 5-41
121246	Clamp, Cable (I.D. 3/8) 5-29,5-37	145220	Modification Kit 5-44	146170	Bracket, Left Middle 5-41
121247	Clamp, Cable (I.D. 7/16) 5-10,5-35	145231**	Panel 5-40	146171	Plate, Mountina (Top) 5-41
121248	Clamp, Cable (ID 1/2) 5-32,5-46	145236**	Door 5-40	146173	Plate, Mountina (Center) 5-41
121249	Clamp, Cable (ID 5/8) 5-35	145237	Panel, Plastic 5-40	146179	Plate, Mountina (Bottom) 5-41
121533	Terminal 5-40	145238	Plate, Desianation 5-40	146185	Slide, Left (Center & Bottom) 5-41
121575	Screw (1--32 x 5/16 Hex) 5-42,5-44	145239**	Bar, Guide 5-40	146186	Slide, Right (Center & Bottom) 5-41
121605	Bushing 5-41,5-54	145241	Panel, Fuse 5-40	146187	Slide, Left (Top) 5-41
124955	Bumper, Rubber 5-36	145244	Cable Assembly, AC Input 5-24	146188	Slide, Riagt (Top) 5-41
124999	Switch, Sensitive 5-17,5-52	145251	Washer, Cup 5-40,5-53	146189	Latch 5-41
125002	Screw (8-32 x 3/8 Flat) 5-40,5-43	145252	Panel, Plastic 5-46	146190	Bracket, Channel 5-41
125011	Washer, Flat 5-6,5-17,5-29	145253	Lamp, Neon 5-44	146291	Cable 5-55
125014	Washer, Flat 5-45	145254	Lens, Indicator Light (Clear) 5-2	146332	Bushing 5-41
125015	Washer, Flat 5-3,5-4,5-6,5-15,5-19,5-27,5-29,5-31,5-32,5-54	145256	Connector, Plua (3 Pt) 5-24,5-40	150040	Screw (6-40 x 5/8 Fil) 5-2,5-3,5-4,5-6,5-14,5-15,5-44,5-48
125108	Screw (6-32 x 3/8 Fil) 5-33,5-39,5-40	145264	Cable Assembly 5-40	150323	Washer, Flat 5-43,5-56
125110	Screw (4-36 x 3/16 Fil) 5-9	145265	Cable Assembly 5-40	150361	Spacer 5-21
125139	Screw (4-40 x 1/8 Fil) 5-10	145266	Fusetron (15 Amp) 5-40	150411	Washer, Flat 5-28,5-29
125170	Screw (8-32 x 5/16 Fil) 5-22	145277	Cable Assembly 5-17	150710	Screw (6-40 x 1-1/4 Fil) 5-13
125185	Screw (10-32 x 1/4 Rd) 5-36	145278	Modification Kit 5-17	150964	Screw, Shoulder (6-40) 5-31
125218	Nut (1/4-32 Hex) 5-3,5-4,5-15,5-41	145281	Rina, Lockina 5-46,5-48	150966	Insulator 5-12,5-13,5-20,5-37,5-38,5-42,5-56
125224	Nut (1/4-32 Hex) 5-23,5-45	145317	Screw, Thumb (6-40) 5-42	151113	Strip 5-37,5-42
125231	Nut (10-32 Hex) 5-2,5-3,5-4,5-12,5-13,5-14,5-15,5-34,5-35,5-38	145318	Screw, Thumb (6-40) 5-42	151118	Plate, Spacina 5-37,5-42
125802	Washer, Flat 5-39	145430	Plate, Oil 5-42	151146	Plate, Mountina 5-37,5-42
126959	Washer, Flat 5-30	145435**	Base, Frame 5-39	151152	Screw (4-40 x 3/16 Hex) 5-17
128357	Rina, Retainina 5-2	145445	Pad, Felt 5-39	151229	Washer, Felt 5-52
129219	Clip, Battery 5-38	145446**	Panel, Front 5-39	151335	Stud 5-2,5-13,5-20,5-27,5-30,5-35,5-37,5-38,5-42,5-55,5-56
129382	Grommet 5-27	145448**	Plate, Duct 5-39	151346	Screw (6-40 x 3/8 Fil) 5-3,5-4,5-10,5-15,5-29,5-30
129502	Resistor (100-Ohms) 5-13	145450	Modification Kit 5-46	151411	Block, Terminal 5-27,5-30
129514	Spacer 5-40	145451	Bracket 5-39	151412	Insulator 5-27,5-30
129919	Fuse (4 Amps) 5-37	145452**	Panel, Right Side 5-39	151415	Block, Terminal 5-12,5-13,5-20,5-37,5-38,5-42,5-56
131228	Washer, Insulating 5-56	145453**	Panel, Left Side 5-39	151416	Nut (6-40 Hex) 5-12,5-13,5-20,5-27,5-30,5-37,5-38,5-40,5-42,5-44,5-46,5-56
136859	Hclder, Plua 5-30	145454**	Cover, Top 5-39	151427	Plate, Clamp 5-56
136884	Cable Assembly 5-21	145455**	Cover, Bottom 5-41	151435	Insulator 5-2,5-56
138225	Block, Terminal 5-35,5-56	145456**	Cover, Middle 5-41	151436	Cover 5-56
139158	Connector, Receptacle 5-56	145457**	Cover, Top 5-41	151442	Screw (6-40 x 1/2 Hex) 5-3,5-32
144600	Modification Kit 5-44	145458**	Cover 5-39	151500**	Cabinet 5-2
144966	Bracket, Left 5-43	145459**	Frame, Outer 5-39	151503**	Door, Small 5-2,5-14
144967	Bracket, Riagt 5-43	145460	Bracket 5-41,5-54	151504	Gasket, Door 5-2,5-14
144969	Brace, Lower 5-43	145464	Kevlever (LOC CR) 5-41,5-54	151505	Gasket, Dome 5-2,5-14
144971	Brace, Upper 5-43	145465	Kevlever (LOC LF) 5-41,5-54	151506	Latch 5-2,5-14
144972	Bracket 5-43	145466	Sprina 5-39,5-41,5-54	151507	Button, Push 5-2,5-14
144974	Bracket 5-43	145467**	Door 5-41	151508	Sprina, Torsion 5-2,5-14
144979	Relay 5-56	145468	Clamp, Right 5-41	151509	Washer, Rubber 5-2,5-14
144989	Plate, Desianation 5-48	145469	Plate, Base 5-42	151511	Gasket 5-2,5-4,5-15,5-28,5-31,5-41
		145470	Link 5-42	151512	Seal, Noise 5-2,5-14
		145471	Link 5-42		
		145476	Bracket 5-42		
		145481	Plate 5-43		
		145487	Screw, Shoulder (6-40) 5-42		
		145488	Cable Assembly 5-42		
		145489	Cable Assembly 5-42		
		145490	Bolt, Latch 5-41,5-54		
		145491	Extension 5-41,5-54		

## NUMERICAL INDEX - SECTION 5 (Continued)

Part Number	Description and Page Number	Part Number	Description and Page Number	Part Number	Description and Page Number
151513	Retainer, Window 5-2,5-14	151598	Bushing 5-2	152464	Insulator 5-37,5-42,5-55
151514	Bar, Dome Latch 5-2,5-14	151599	Lever 5-2,5-14	152465	Connector, Receptacle (20 Pt) 5-24,5-56
151515	Button, Push 5-2,5-14	151616	Screw, Self Tapping 5-2	152466	Connector, Receptacle (20 Pt) 5-10,5-24,5-29,5-35,5-57
151516	Bracket 5-15	151618	Screw (6-40 x 7/16 Fil) 5-5,5-29	152467	Connector, Plug (20 Pt) 5-42,5-55
151519	Arm, Latch 5-2,5-14	151626	Terminal 5-2,5-3,5-4,5-12,5-13,5-15,5-17,5-20,5-22,5-28,5-30,5-35,5-37,5-38,5-42,5-49,5-52,5-56	152755	Strap, Terminal 5-40
151521	Stud 5-3,5-4,5-15	151629	Nut (6-40 Lug) 5-56	152767**	Dome 5-2,5-14
151522	Rail, Side Cradle 5-3,5-4,5-15	151630	Screw (6-40 x 1/4 Hex) 5-3,5-4,5-10,5-12,5-13,5-15,5-16,5-19,5-25,5-27,5-28,5-30,5-34,5-37,5-38,5-39,5-42,5-56	152768	Windwo 5-3,5-4,5-15
151523	Hub 5-2,5-14	151631	Screw (6-40 x 5/16 Hex) 5-9,5-10,5-13,5-20,5-21,5-26,5-28,5-29,5-30,5-31,5-32,5-37,5-42,5-44	152797**	Plate 5-14
151524	Hinae, Cradle 5-3,5-4,5-15	151632	Screw (6-40 x 3/8 Hex) 5-6,5-27,5-28,5-31,5-37,5-38,5-39,5-40,5-42,5-44,5-46,5-56	152848	Screw, Truss Head 5-6,5-7,5-8,5-23,5-51
151525	Rail, Rear Cradle 5-4,5-4,5-15	151637	Screw (4-40 x 1/4 Fil) 5-8,5-9,5-31	152882	Arm, Counterbalance (Left) 5-2,5-14
151526	Screw, Thumb 5-2	151657	Screw (6-40 x 1/4 Fil) 5-2,5-5,5-12,5-13,5-14,5-20,5-25,5-26,5-51,5-52	152883	Arm, Counterbalance (Right) 5-2,5-14
151527**	Bar, Cross 5-2,5-14	151658	Screw (6-40 x 5/16 Fil) 5-3,5-4,5-5,5-7,5-25,5-37,5-42,5-55	152884	Screw (12-24 x 1 Hex) 5-2,5-14
151528	Spring 5-15	151659	Screw (6-40 x 1/2 Fil) 5-10,5-40,5-44	152899**	Plate, Retaining 5-7
151529	Plate, Ballast 5-3	151685	Screw (4-40 x 5/16 Fil) 5-4,5-8,5-25,5-27,5-30,5-51	152901**	Modification Kit 5-8
151530**	Hinae, Dome 5-2,5-14	151686	Screw (4-40 x 3/8 Fil) 5-3,5-28	152902	Modification Kit 5-9
151531	Plate, Starter 5-3	151687	Screw (4-40 x 7/16 Fil) 5-33,5-39	152910**	Modification Kit 5-7
151532**	Cover W/Plate 5-14	151691	Screw (10-32 x 3/8 Fil) 5-12,5-40	152923**	Cover W/Catch 5-25
151534	Screw, Shoulder (10-32) 5-2,5-14	151692	Screw (6-40 x 3/16 Fil) 5-2,5-14,5-25,5-28,5-31	152924	Stud 5-26
151536	Guide, Cable 5-2,5-14	151693	Screw (6-40 x 9/16 Fil) 5-29,5-56	152925	Latch 5-26
151537	Copyholder 5-15	151718	Socket, Lamp 5-3	152942	Cable Assembly 5-26
151538	Spring, Torsion 5-2,5-14	151722	Screw (6-40 x 3/16 Hex) 5-3,5-28,5-31,5-41,5-42,5-55,5-56	152968	Plate, Nut 5-26
151540	Lampholder 5-3,5-4,5-9,5-10,5-12,5-13,5-15,5-20,5-26,5-27,5-28,5-30,5-31,5-49,5-56	151723	Screw (10-32 x 3/8 Hex) 5-2,5-3,5-13,5-14,5-17,5-34,5-37,5-43	152969**	Plate Assembly, Base 5-26
151541	Shaft W/Fork 5-14	151724	Screw (10-32 x 5/8 Hex) 5-12,5-21,5-35,5-41,5-56	152971	Bushing 5-26
151542	Stud 5-2,5-14	151725	Screw (10-32 x 3/4 Fil) 5-35	152972	Handle 5-26
151544	Shield, Light 5-3	151726	Bumper 5-2	152973**	Plate W/Strikes 5-26
151545	Guide, Paper 5-2,5-14,5-25,5-28,5-31,5-41	151727**	Extension, Hinae 5-2,5-14	152993	Screw, Shoulder (10-32) 5-26
151547	Spring 5-15	151819	Jumper 5-2	153017	Nut, Lock 5-23,5-43,5-56
151548	Spring 5-15	151827	Strap, Terminal 5-27,5-30,5-40	153020	Guide, Line 5-3,5-4,5-25,5-27,5-30
151549	Post 5-3,5-4,5-15,5-26,5-28,5-31,5-34	151880	Nut (4-40 Hex) 5-40	153021	Spring 5-3,5-3,5-8,5-25,5-27,5-30,5-51
151550	Cable Assembly 5-3	151955	Guide, Cable 5-3,5-4,5-15	153022	Bushing 5-3,5-4,5-8,5-25,5-27,5-30,5-51
151551	Copylight Assembly 5-3	151956	Guide, Cable 5-2,5-14	153023	Handle 5-3,5-4,5-8,5-25,5-27,5-30,5-51
151553	Foot 5-2	151982	Lamp, Incandescent (6 V) 5-4,5-12,5-13,5-16,5-27,5-30,5-31,5-37,5-39,5-42	153024	Shaft 5-4
151555	Foot, Mounting 5-3,5-4,5-15	151983	Shield, Light 5-4,5-15,5-26,5-27,5-30	153027	Post 5-4
151556	Knob 5-2,5-14	151988	Modification Kit 5-22	153032	Bracket, Detent 5-2
151557	Lens 5-25	151989	Suppressor, Electrical Noise 5-22	153033	Arm, Detent 5-2
151558	Nut, Speed 5-2,5-9,5-14,5-25,5-27,5-30	152056	Guide, Cable 5-2	153034	Shaft Assembly 5-2
151559	Spring 5-2,5-14	152300**	Modification Kit 5-7	153035**	Panel 5-2
151560	Bell Assembly 5-3,5-4,5-15	152309	Copylight Assembly 5-4	153036	Shaft 5-2
151562	Lamp, Incandescent (115 V) 5-3	152310	Indicator Assembly 5-4,5-15	153037	Spring 5-2
151564	Bracket Assembly 5-3,5-4,5-15,5-29	152313	Modification Kit 5-26	153039	Handle 5-2
151565	Bushing, Shoulder 5-3,5-4,5-15,5-29	152314	Modification Kit 5-26	153042	Window 5-3,5-4,5-25
151567	Armature W/Clapper 5-3,5-4,5-15,5-29	152319	Modification Kit 5-11	153046	Copyholder Assembly 5-3
151569	Strap, Grounding 5-3,5-4,5-15	152349**	Modification Kit 5-5	153047	Copyholder Assembly 5-15
151571	Cable Assembly 5-3,5-4,5-15	152426	Nut, Self-Locking 5-5,5-56	153048	Wing Stud, Oval 5-2
151572	Washer, Lock 5-3,5-4,5-15,5-36	152460	Bracket 5-37	153099	Arm, Pivot 5-8,5-51
151573**	Panel 5-14	152462	Latch, Right 5-37,5-42,5-55	153100**	Cabinet 5-2
151574	Grommet, Rubber 5-3,5-4,5-15,5-29	152463	Latch, Left 5-37,5-55	153103	Screw (4-40 x 3/16 Rd) 5-39
151575	Arm, Stop 5-15			153104	Bracket 5-8
151576	Arm, Stop 5-15			153106**	Plate, Bearing 5-8
151577	Screw, Shoulder (6-40) 5-3,5-4,5-15,5-29			153107	Arm 5-6,5-8,5-51
151578	Hinae 5-2,5-14			153113	Guide, Line 5-8,5-51
151579	Plate, Retaining 5-3,5-14,5-15,5-29			153126	Plate, Nut 5-8,5-51
151588	Mount, Vibration 5-9			153130**	Copyholder 5-8
151589	Cradle Assembly 5-3,5-4,5-15			153252	Link 5-42
151590	Indicator Assembly, Margin 5-3			153388	Stud 5-2,5-12,5-14
151594	Mount, Vibration 5-18			153390**	Cover 5-25
151595	Arm Assembly, Dome Stop 5-15			153391	Plate, Clamp 5-25
151596	Arm Assembly, Small Door Stop 5-15			153392	Pad, Side 5-25
151597**	Panel Assembly 5-14			153393	Pad, Front 5-25
				153394	Pad, Rear 5-25
				153395	Plate, Nut 5-25

1149B

NUMERICAL INDEX - SECTION 5 (Continued)

Part Number	Description and Page Number	Part Number	Description and Page Number	Part Number	Description and Page Number
153397	Arm, Cover 5-25	154869**	Bracket W/Nuts 5-8	157985	Cable Assembly 5-17
153400	Lamp, Incandescent (60V) 5-4, 5-9, 5-15, 5-20, 5-21, 5-26, 5-28, 5-44, 5-49, 5-53	154874	Connector, Plug (2 Pt) 5-9	157986	Cable Assembly 5-17
153403	Tray 5-25	155023	Switch, Toggle 5-40, 5-56	157992	Bracket 5-10
153441	Screw (10-32 x 7/16 Hex) 5-38	155045	Switch, Toggle 5-4, 5-12, 5-13, 5-20	157993	Bracket 5-10
153442	Screw (10-32 x 1/2 Hex) 5-2, 5-3, 5-4, 5-12, 5-13, 5-14, 5-20, 5-29, 5-34, 5-35, 5-37, 5-38, 5-41, 5-42, 5-43, 5-50	155063	Pad, Rubber 5-20, 5-21	157999	Bracket 5-12
153455	Resistor (600 Ohms) 5-26, 5-49	155083	Lens, Indicator Light (Red) 5-2, 5-9, 5-14, 5-27, 5-30	158250	Block, Terminal 5-40, 5-42, 5-44, 5-46, 5-55
153459	Block, Terminal 5-2, 5-10, 5-11, 5-14, 5-29	155085**	Bracket 5-8	158252	Insulator 5-40, 5-42, 5-44, 5-46, 5-55
153465	Nut (6-32 Hex) 5-11	155086	Pad, Rubber 5-8	158258	Connector, Plug (20 Pt) 5-37
153466	Cover 5-11, 5-14	155087	Screw (1/4 x 20 x 7/16 Rd) 5-8	158259	Connector, Receptacle (20 Pt) 5-35
153467	Insulator 5-11	155088**	Holder, Directory 5-7	158286	Transformer 5-27, 5-29, 5-30, 5-37, 5-42, 5-56
153468	Insulator 5-2, 5-11, 5-14, 5-29	155547	Bracket, Left 5-6	158491	Copyright Assembly 5-20
153469	Strip W/Screws 5-11	155548	Bracket, Right 5-6	158492	Cable Assembly 5-20
153470	Insulator 5-2, 5-11, 5-14, 5-29	155563	Plate, Mounting 5-21	158493	Cable Assembly 5-20
153471	Strip W/Screws 5-11	155597	Lens, Indicator Light (Yellow) 5-2, 5-16	158494	Bracket 5-20
153474	Cable Assembly 5-4	156614	Cover 5-10	158649	Screw, Thumb (4-40) 5-40, 5-41
153484	Screw (6-32 x 1/4 Rd) 5-2, 5-10, 5-11, 5-14, 5-29	156723	Screw (4-48 x 1/2 Fil) 5-10	159273	Copyright Assembly 5-12
153486	Bracket, Switch 5-4	156725	Sleeve, Insulating 5-29	159274	Cable Assembly 5-12
153487	Cable Assembly 5-3, 5-3, 5-15, 5-31, 5-37, 5-49	156750	Sleeve, Insulating 5-20, 5-21	159275	Transformer Assembly 5-12
153488**	Cabinet 5-2	156751	Sleeve, Insulating 5-28, 5-29, 5-30	159357	Modification Kit 5-12
153492	Connector, Receptacle (3 Pt) 5-26	156766	Clamp, Cable 5-10	159373	Modification Kit 5-6
153537	Screw (6-40 x 9/32 Hex) 5-8, 5-28, 5-35, 5-37, 5-42, 5-51	156846	Bushing, Adapter 5-18	159375	Modification Kit 5-21
153538	Screw (6-40 x 7/16 Hex) 5-30, 5-54	156857	Retainer 5-29	159390	Modification Kit 5-23
153540**	Cabinet 5-14	156858	Resistor (700 Ohm) 5-20, 5-21	160224	Modification Kit 5-16
153541**	Cover 5-14	156859	Screw (4-40 x 1/8 Rd) 5-10, 5-24	160225	Cable Assembly 5-16
153622	Wire 5-21	156860	Screw (4-40 x 3/8 Rd) 5-10, 5-24, 5-29	160282	Bracket, Right 5-23
153817	Screw (4-40 x 3/8 Hex) 5-29	156861	Washer, Lock 5-10, 5-24, 5-29	160283	Bracket, Left 5-23
153830	Guide, Rear Paper 5-7	156862	Spring 5-2, 5-14	160339	Window 5-28, 5-31, 5-41
153833	Bracket, Guide 5-7	156899	Nut, Spring Adjusting Screw 5-2, 5-14	160341	Bracket 5-41
153834**	Shelf, Paper 5-5	156740	Screw (6-40 x 7/32 Hex) 5-29, 5-35, 5-54, 5-56	160344	Clamp 5-41
153835**	Plate, Deflector 5-5	156770	Plate, I.D. (Teletype) 5-2, 5-14, 5-27, 5-30, 5-34, 5-39	160349	Bracket 5-41
153836**	Bracket, Back Stop 5-5	156993	Nut, Speed 5-2, 5-14, 5-27, 5-30, 5-34, 5-39	160394	Lens, Indicator Light (Red) 5-16
153837**	Shelf, Paper Box 5-5	157152	Modification Kit 5-10	160461	Bracket 5-10
153841	Screw (6-40 x 9/16 Hex) 5-25, 5-32, 5-56	157153	Bracket Assembly 5-10	160974	Arm, Stop 5-27, 5-30
153842	Clip, Paper Holder 5-5	157154	Insulator 5-10, 5-29	161705	Strike, Fastener 5-39
153882	Mount, Shock 5-26	157155	Cover W/Insulator 5-10	161087	Insulator 5-35
153900**	Modification Kit 5-8	157156	Cable Assembly 5-10, 5-29	161306	Modification Kit 5-3
153901**	Modification Kit 5-6	157157	Modification Kit to Add Busy Light 5-10	161708	Latch, Magnetic 5-29, 5-39
153920	Modification Kit 5-10	157158	Cable Assembly 5-10	161747	Plate, Nut 5-29
153926	Modification Kit 5-7	157159	Plate 5-9, 5-10	161748	Screw (5/16-18 x 27/64 Flat) 5-33, 5-39
154251	Latch 5-28, 5-40	157160	Cable Assembly 5-9	161750	Bracket 5-10
154256	Screw, Thumb (4-40) 5-27, 5-28, 5-31	157260	Cable Assembly 5-10	161994	Bracket, Terminal Block 5-35
154258	Shaft 5-30	157278	Cable Assembly 5-11, 5-12, 5-27, 5-30	161995	Bracket, Terminal Block 5-35
154308	Pad, Base 5-2, 5-14	157280	Cable Assembly 5-13	161998	Name Plate, Teletype 5-39
154348	Plate (On-Off) 5-2	157281	Transformer Assembly 5-13	162333	Stud, Locating 5-37, 5-42
154399	Plate, I.D. (Bell) 5-2, 5-14, 5-27, 5-30, 5-34	157282	Bracket W/Pad 5-13	162370	Cable Assembly 5-10
154404	Tray, Copyholder 5-3, 5-4	157393	Grommet, Rubber 5-10	162590	Shaft 5-3, 5-25
154409**	Plate 5-33, 5-39	157399	Connector, Receptacle 5-10	162627	Nut, Speed (#6) 5-39
154433	Clamp 5-28, 5-31, 5-54	157532	Modification Kit to Provide Auxiliary Terminal Block and Cables 5-10	162687	Screw, Self Tapping (#6) 5-39
154651	Modification Kit 5-22	157878	Screw (1/2-13 x 5/8 Hex) 5-19	162692	Pin 5-35
154655	Suppressor, Electrical Noise 5-22	157880	Bracket 5-19	163040	Pad, Upper Rear 5-30
154695**	Bracket 5-6	157881	Plate 5-19	163115	Cable Assembly 5-24
154697	Grommet, Rubber 5-6	157882**	Cover, Right 5-19	163116	Cable Assembly 5-24
154741	Modification Kit 5-10	157883**	Cover, Left 5-19	163117	Cable Assembly 5-24
154754**	Modification Kit 5-19	157980	Extension 5-17	163118	Cable Assembly 5-24
154756	Modification Kit 5-17	157981	Bracket 5-17	163119	Cable Assembly 5-24
154777	Modification Kit 5-20	157982	Lever 5-17	163161	Connector, Plug (20 Pt.) 5-24
154793	Modification Kit 5-18	157984	Screw, Shoulder (4-40) 5-17	163635**	Cover 5-27
154868	Plate 5-6			163636	Pad, Lower Side (L & R) 5-27, 5-30
				163637	Pad, Upper Side (L) 5-27, 5-30
				163638	Pad, Upper Side (R) 5-27, 5-30
				163639	Pad, Rear Bottom 5-27, 5-30
				163640	Pad, Rear Upper 5-27
				163641	Pad, Front 5-27, 5-30
				163642	Pad, Lid 5-27, 5-30
				163643	Plate, Base 5-28
				163644	Bracket 5-28, 5-31
				163646	Rail, Base Mounting 5-28, 5-31

## NUMERICAL INDEX - SECTION 5 (Continued)

Part Number	Description and Page Number	Part Number	Description and Page Number	Part Number	Description and Page Number
163796**	Shelf 5-23	172647	Block, Guide 5-34	173916	Cover 5-32
164235**	Bracket 5-23	172650	Slide, Outer 5-34	173917	Pad, Lower Right Side 5-30
164331	Modification Kit 5-29	172651	Slide, Outer 5-34	174438	Screw (1/4-20 x 1 Flat) 5-28,5-31
164332	Modification Kit to Provide Rear Paper Guide 5-28	172654	Slide, Left Center 5-34	174458	Modification Kit 5-49
164333	Cable Assembly 5-29	172655	Slide, Outer Right Center 5-34	176130	Arm, Right Pivot 5-36
164334	Bar, Paper Guide 5-28	172658	Slide, Outer Bottom Right 5-34	176131	Arm, Left Pivot 5-36
164345**	Modification Kit 5-29	172659	Slide, Outer Bottom Left 5-34	176132	Arm, Right Pivot 5-36
164362	Indicator Assembly 5-4	172682	Slide, Middle Right 5-34	176133	Arm, Left Pivot 5-36
164383**	Shelf 5-23	172683	Slide, Middle Left 5-34	176134	Bracket, Mounting 5-33
164384	Cable Assembly 5-27,5-29,5-30	172684	Slide, Inner Right 5-34	176667	Spacer 5-52
164396	Cable Assembly 5-28	172685	Slide, Inner Left 5-34	176668	Bracket 5-52
164397	Cable Assembly 5-28	172693**	Panel, Right Side 5-33	176669	Lever 5-52
164398**	Plate 5-29	172694**	Panel, Left Side 5-33	176670	Lever W/Hub 5-52
164399	Cable Assembly 5-29	172695	Base 5-33	176671	Insulator 5-52
164400	Bell Assembly, Signal 5-29	172696**	Brace, Front Bottom 5-33	176708	Bracket 5-52
164401	Cable Assembly 5-29	172697	Brace, Front Top 5-33	176711	Spring 5-52
164412**	Cover 5-29	172698**	Brace, Bottom Rear 5-33,5-39	176712	Spring 5-52
164419	Plate, Nut 5-29	172699**	Cover, Keytop 5-34	176714	Modification Kit 5-52
164420**	Bracket, Left Mounting 5-29	172700**	Door Assembly 5-36	176786	Cable Assembly 5-52
164421**	Bracket, Right Mounting 5-29	172701**	Top 5-33	177010	Selector, Magnet Assembly 5-56
164422**	Bracket, Mounting 5-29	172702**	Panel, Rear 5-33,5-39	177034	Spring 5-36
164604	Shield, Right Lamp 5-34	172703**	Panel, Top Rear 5-33,5-39	178261	Handle 5-39
164606	Bracket, Mounting 5-35	172711**	Plate, Cover 5-33	178387	Modification Kit 5-50
164607	Bracket, Mounting 5-35	172714	Bracket 5-36	178389	Unit, Power 5-50
164609	Plate, Identification 5-33	172715	Screw, Captive (10-24) 5-33,5-39	178390	Bar, Static Eliminator 5-50
164610	Brace 5-35	172717	Bushing 5-36	178391	Cable 5-50
164613	Bracket, Right Mounting 5-34	172718	Screw, Shoulder (1/4-20) 5-36	178392	Plug 5-50
164614	Bracket, Left Mounting 5-34	172719	Screw, Shoulder (1/4-20) 5-36	178729	Plate 5-49
164615	Plate, Base 5-37	172758	Pad 5-33, 5-39	178840	Capacitor 5-56
164616	Base 5-35	172762	Bumper, Rubber 5-36	178841	Transformer 5-56
164618	Handle 5-37	172763	Retainer, Speed Grip Nut (10-24) 5-33,5-39	178843	Plate 5-56
164619	Plate, Mounting 5-35	172791**	Panel, Front 5-33	178859	Card, Circuit 5-56
164620	Guard, Terminal Block 5-35	172961	Screw, Stop (6-40 x 5/8) 5-37	178866	Resistor (700 Ohms) 5-56
164624	Cable Assembly 5-35	173013**	Frame, Top 5-36	178886	Cable 5-56
164629	Bracket 5-37,5-38	173014**	Frame, Left 5-36	178887	Cable 5-56
164730	Bracket 5-37	173015**	Frame, Right 5-36	178888	Clip 5-56
164733	Shield, Left Lamp 5-34	173016**	Frame, Bottom 5-36	178892**	Copyholder 5-51
164754	Plate, Name (Bell) 5-39	173017	Frame, Door 5-36	178893**	Plate 5-51
164899	Pad, Top Side 5-33	173018	Gasket 5-36	178894**	Bracket 5-51
164900	Pad, Bottom Side 5-33	173019	Panel, Glass 5-36	178895	Shaft 5-51
164901	Pad, Rear Panel 5-33,5-39	173206	Bracket 5-45	178897**	Modification Kit 5-51
164902	Pad, Side Center 5-33	173207	Shelf 5-45	178900**	Cabinet 5-2
164903	Pad, Top Rear 5-33	173238	Modification Kit 5-49	178914**	Plate, Bearing 5-51
164927	Cable Assembly 5-37	173256	Cable Assembly 5-49	179130	Screw, Shoulder 5-41
164928	Cable Assembly 5-37	173712	Cable Assembly 5-36	179131	Screw (10-24 x 5/8 Hex) 5-39
164955	Guide, Right 5-35	173713	Cable Assembly 5-36	179297	Bracket, Left Bottom 5-41
164956	Guide, Left 5-35	173872**	Cover 5-30	179298	Bracket, Right Bottom 5-41
164999	Cable Assembly 5-38	173874	Pad, Upper Right Side 5-30	179299**	Door 5-39
165103	Screw (12-24 x 5/8 Spl.) 5-43,5-56	173875	Pad, Upper Rear 5-30	179300**	Frame 5-39
165118	Socket, Lamp 5-46	173876	Bracket, Connector 5-30	179307	Panel 5-56
165167	Lamp, Neon 5-46	173877	Cable Assembly 5-30	179372	Shield 5-39
165168	Key 5-44,5-46	173878	Plate, Base 5-31	179375	Cable Assembly 5-56
165261	Screw (4-40 x 3/8 Oval) 5-40,5-46,5-48	173879	Cable Assembly 5-30	179376	Cable 5-56
171541	Diode 5-56	173913**	Cover 5-30	179378	Retainer, Keylever 5-54
172646	Block, Support 5-34	173914	Plate, Base 5-32	179495	Screw (10-24 x 1/2 Hex) 5-39
		173915	Block, Mounting 5-32		

**SECTION 6**  
**ELECTRICAL SERVICE UNIT**

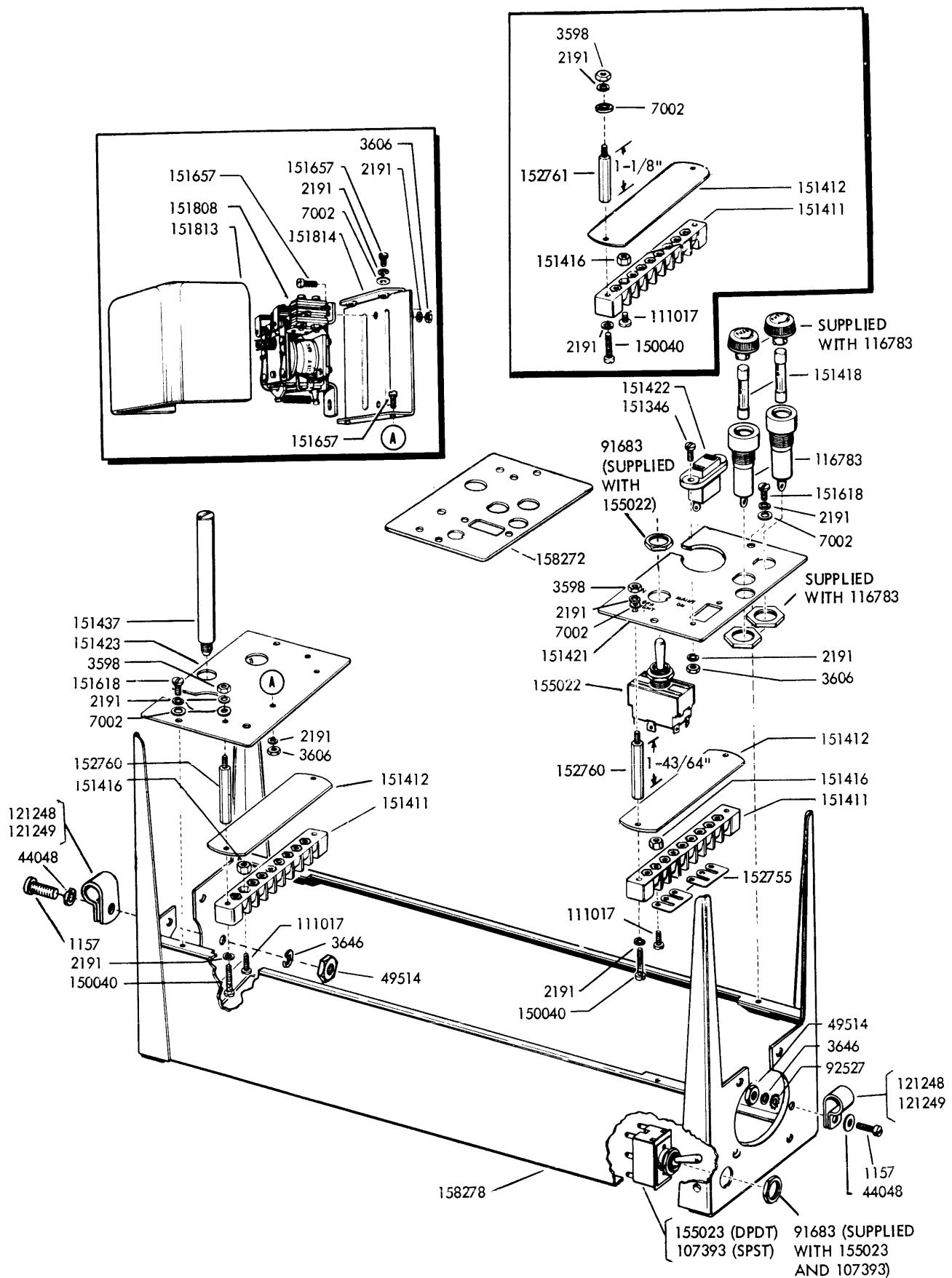
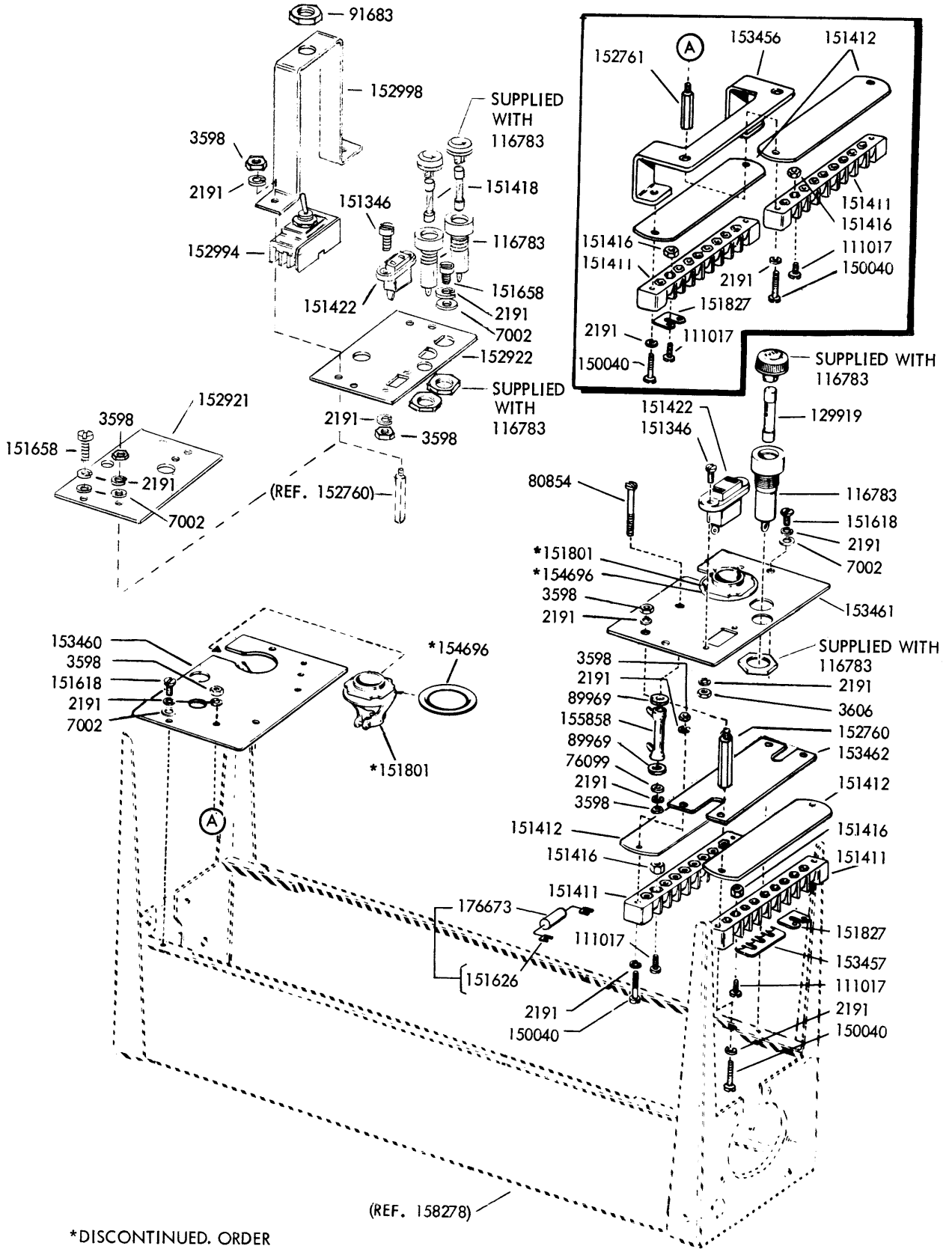


FIGURE 6-1. ELECTRICAL SERVICE UNIT





\*DISCONTINUED. ORDER  
173724 MODIFICATION KIT.  
SPECIFICATION 5995S

FIGURE 6-2. ELECTRICAL SERVICE UNIT

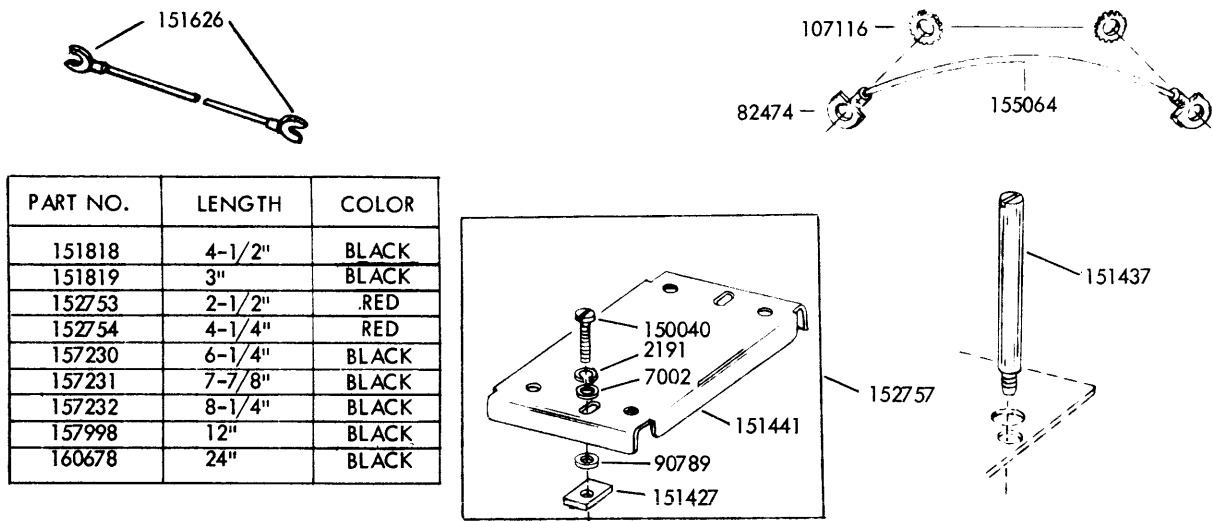


FIGURE 6-3. VARIABLES FOR THE ELECTRICAL SERVICE UNIT

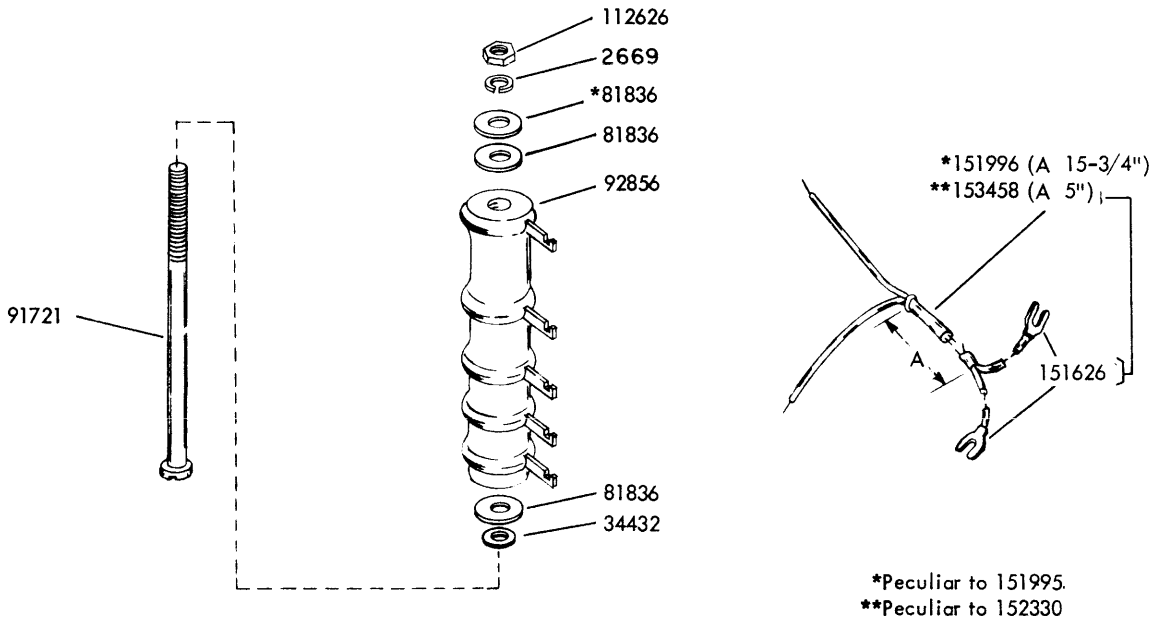


FIGURE 6-4. 151995 AND 152330 MODIFICATION KITS TO ADD LINE PAD RESISTOR TO LESU

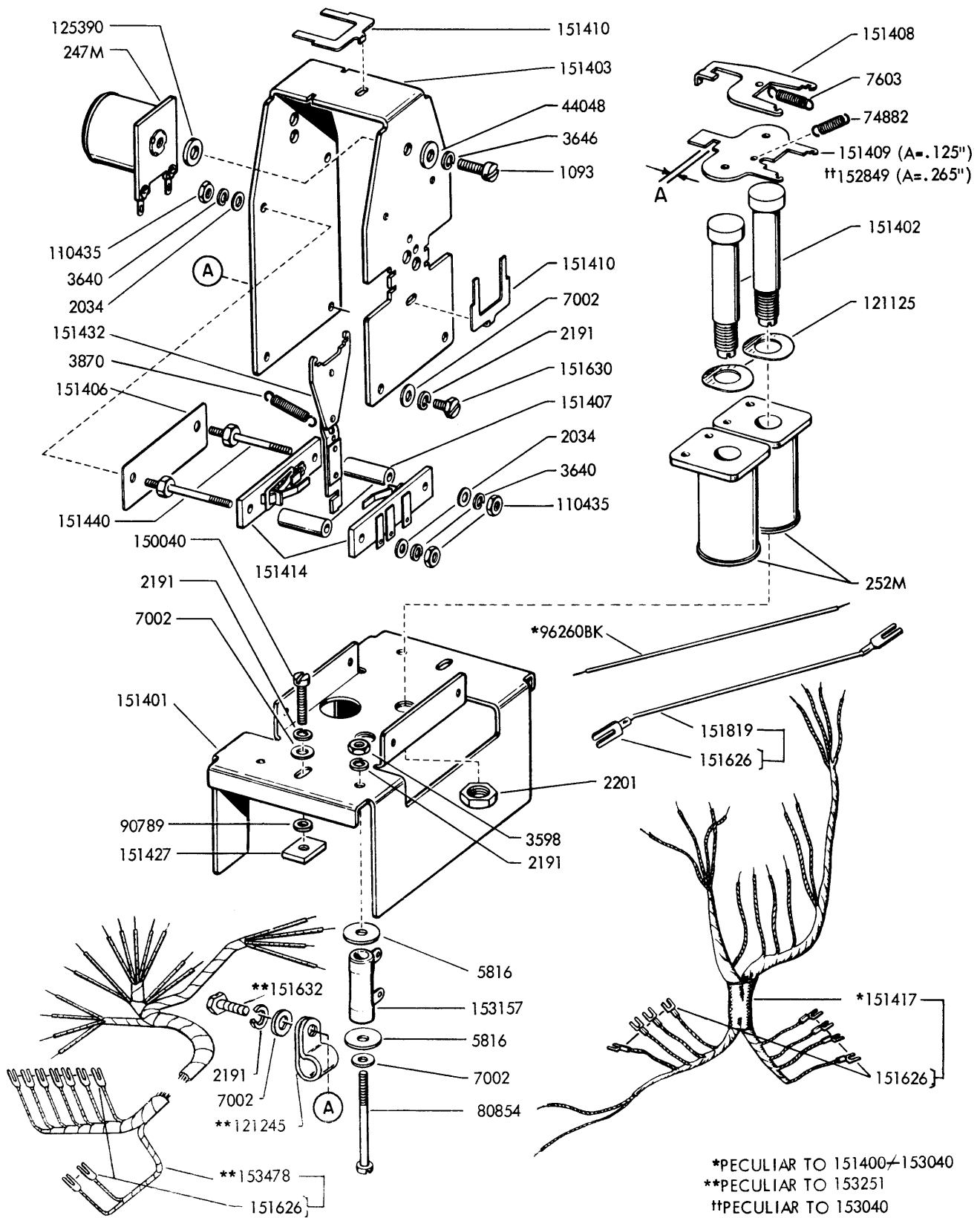
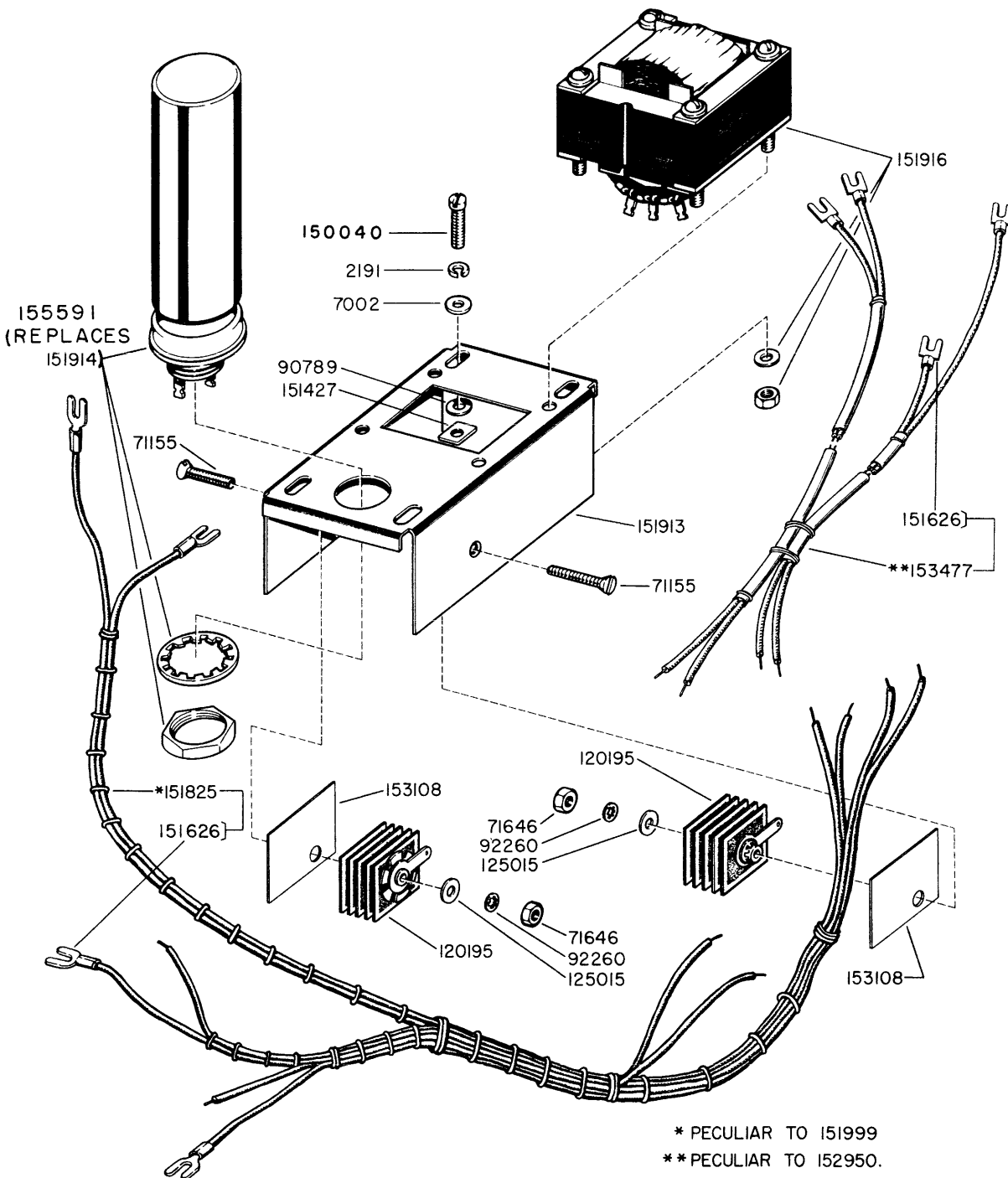


FIGURE 6-5. 151400, 153040 AND 153251 ELECTRICAL MOTOR CONTROL ASSEMBLIES



SPECIFICATION 5707S

FIGURE 6-6. 151999 AND 152950 RECTIFIER AND CABLE ASSEMBLIES (120 MA)

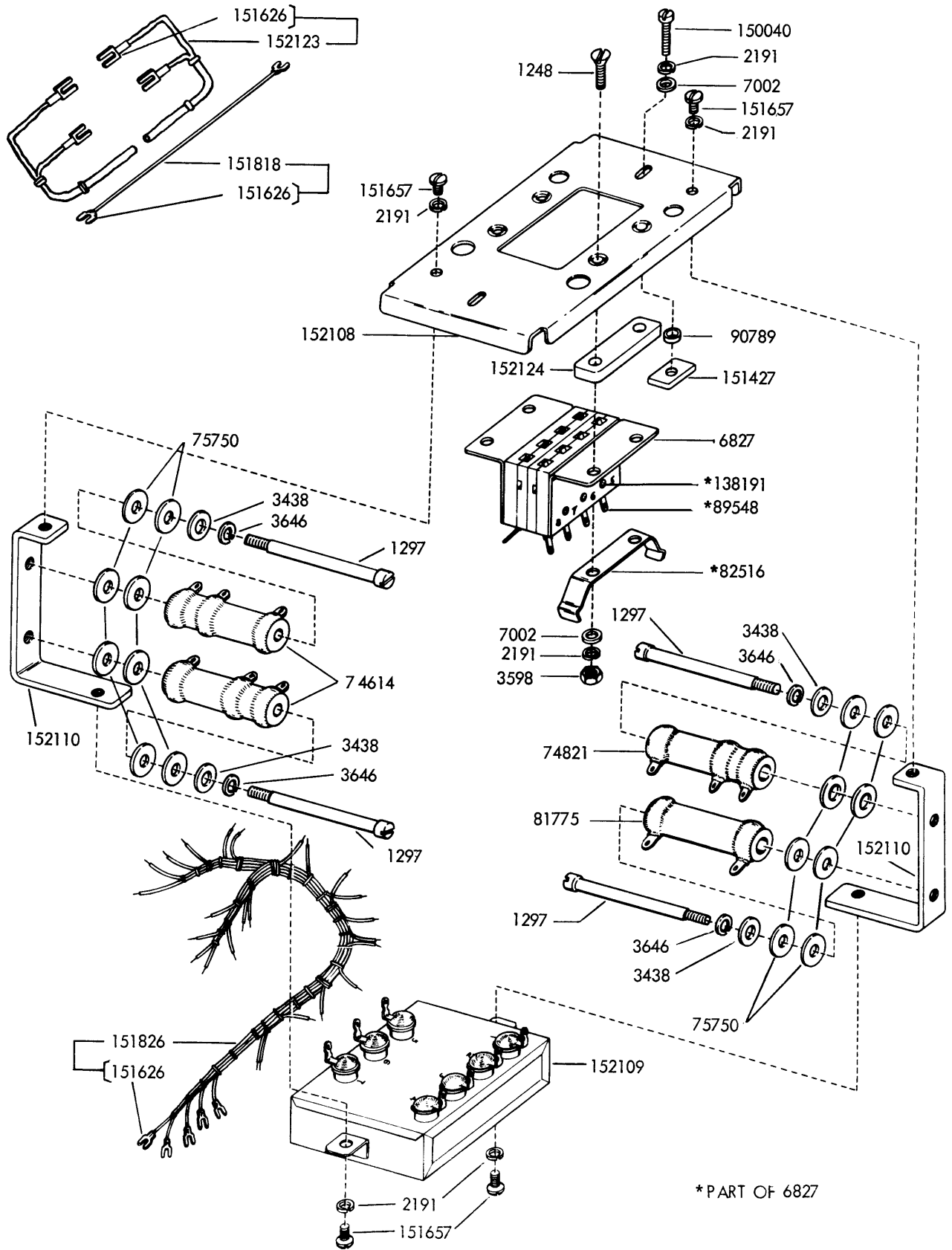


FIGURE 6-7. 151822 LINE RELAY MOUNTING ASSEMBLY

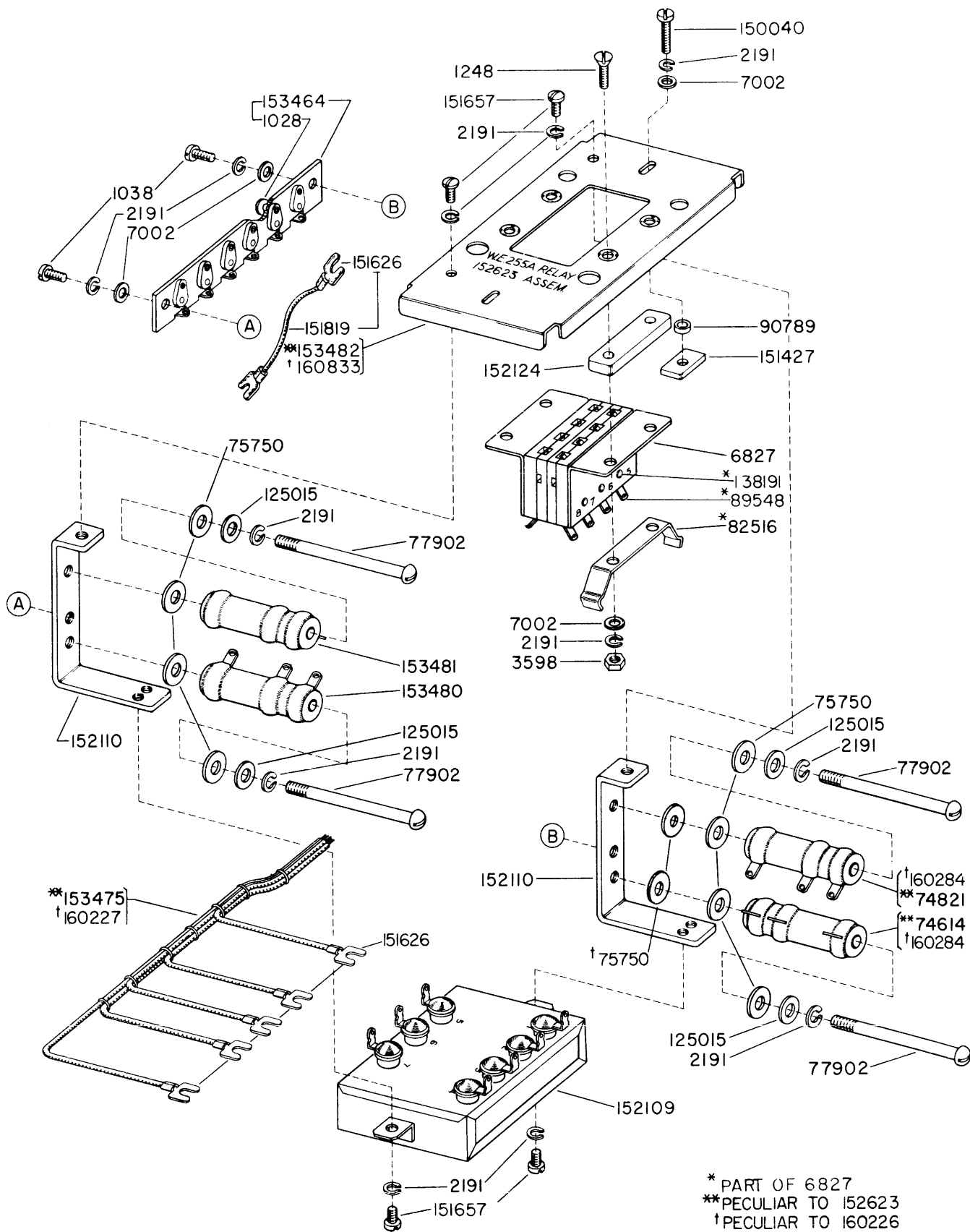


FIGURE 6-8. 152623 AND 160226 LINE RELAY MOUNTING ASSEMBLIES

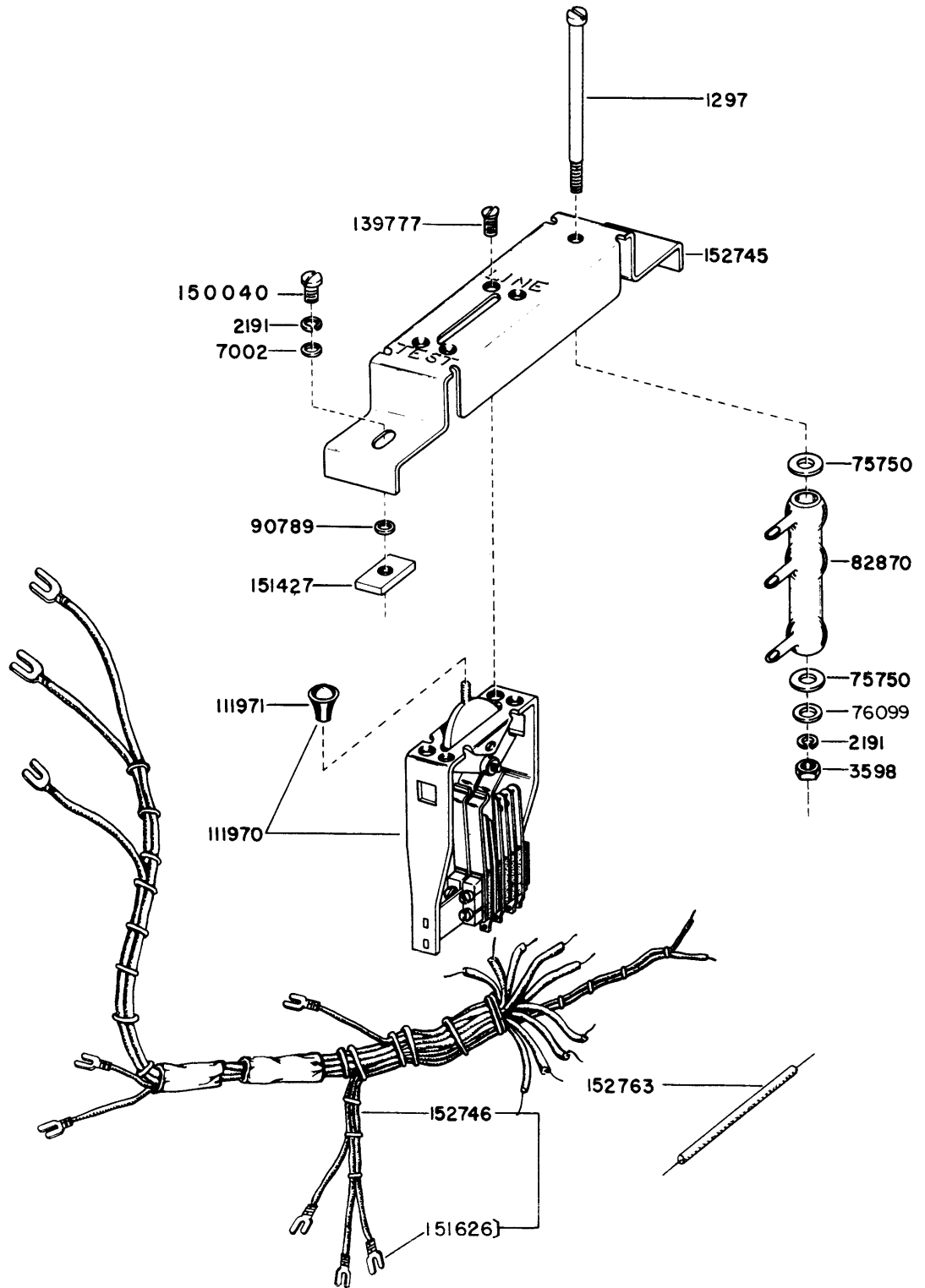


FIGURE 6-9. 152744 LINE TEST KEY ASSEMBLY

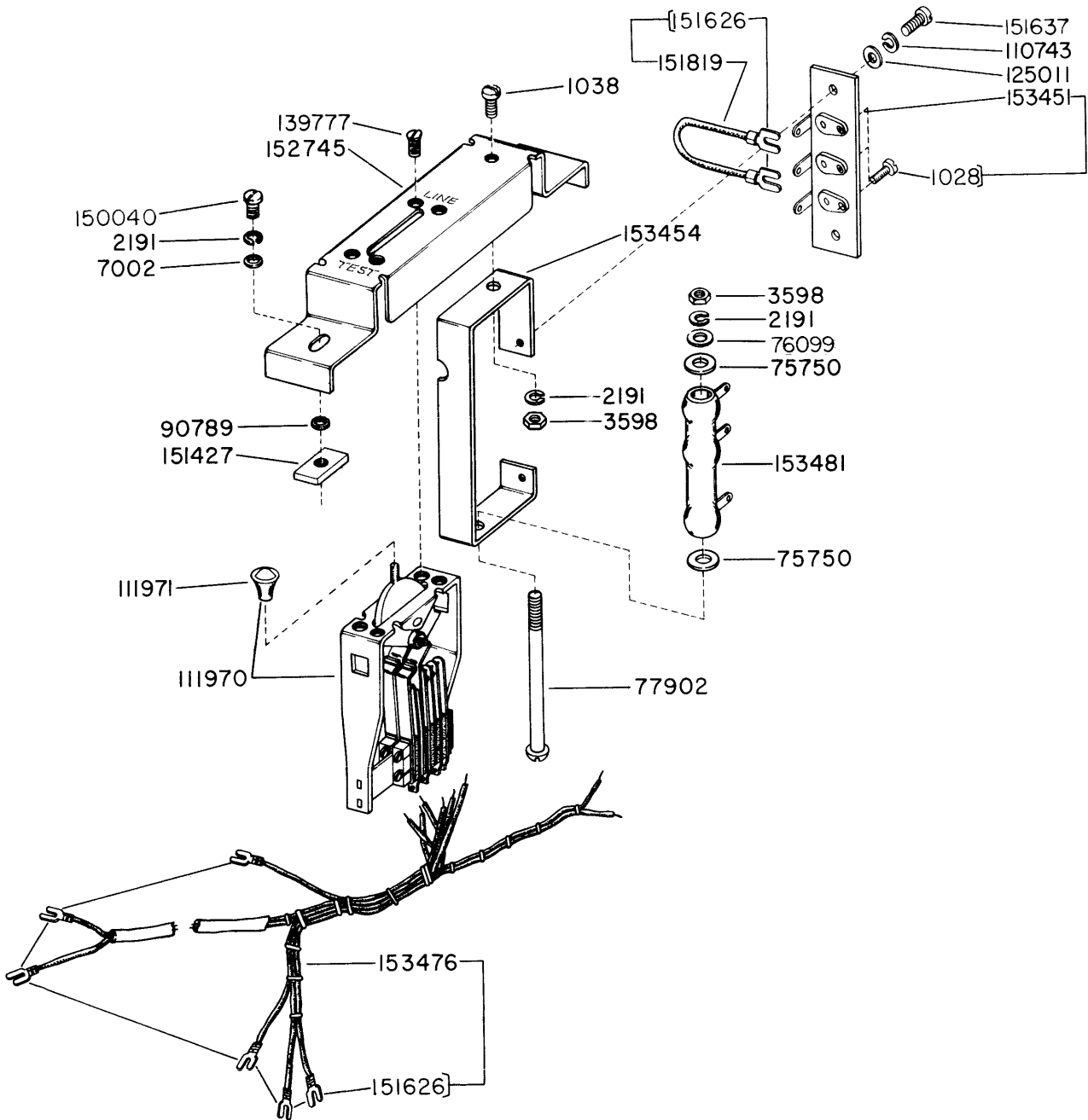


FIGURE 6-10. 152625 LINE TEST KEY ASSEMBLY



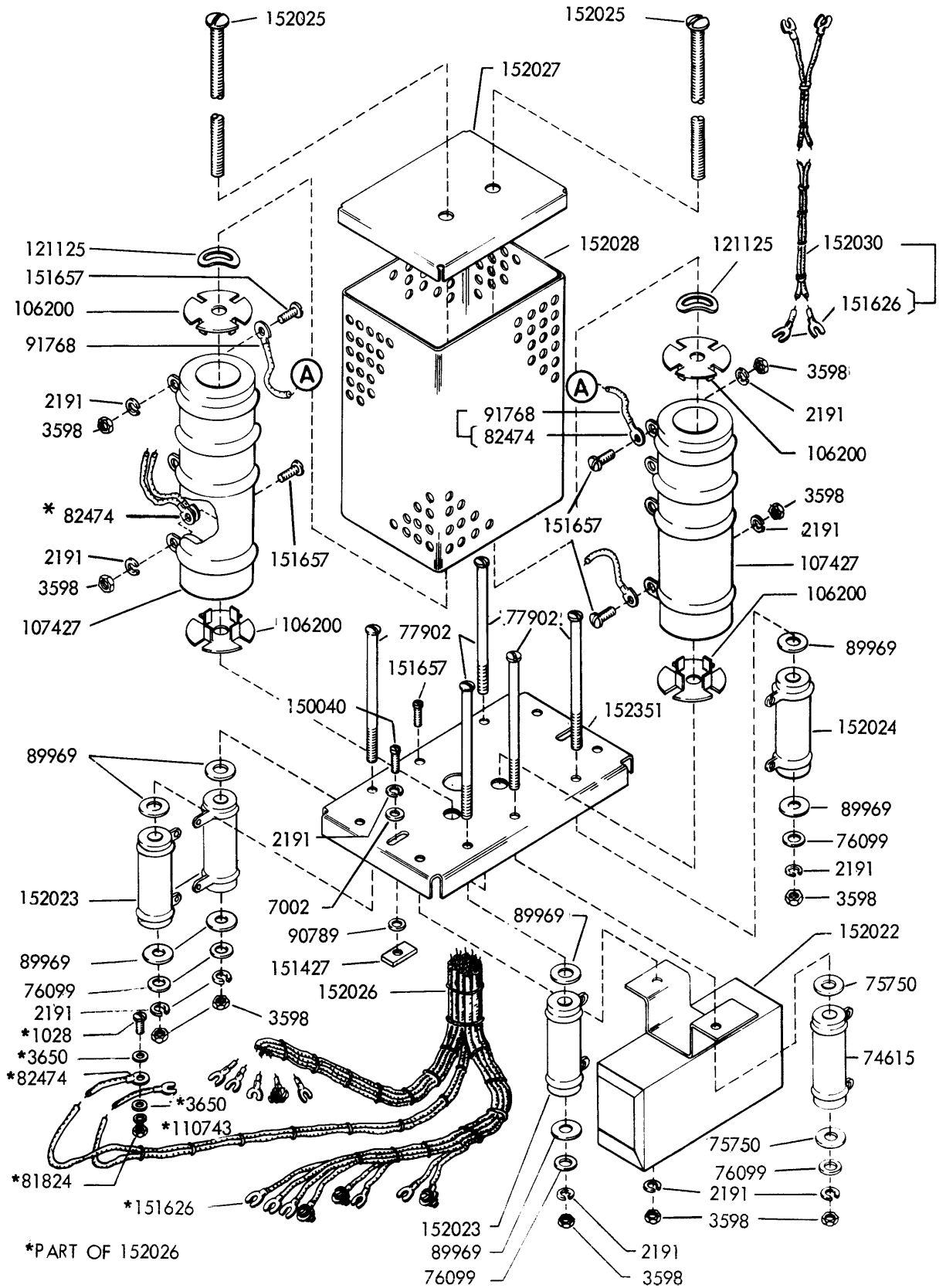


FIGURE 6-11. 152021 CAPACITOR-RESISTOR ASSEMBLY

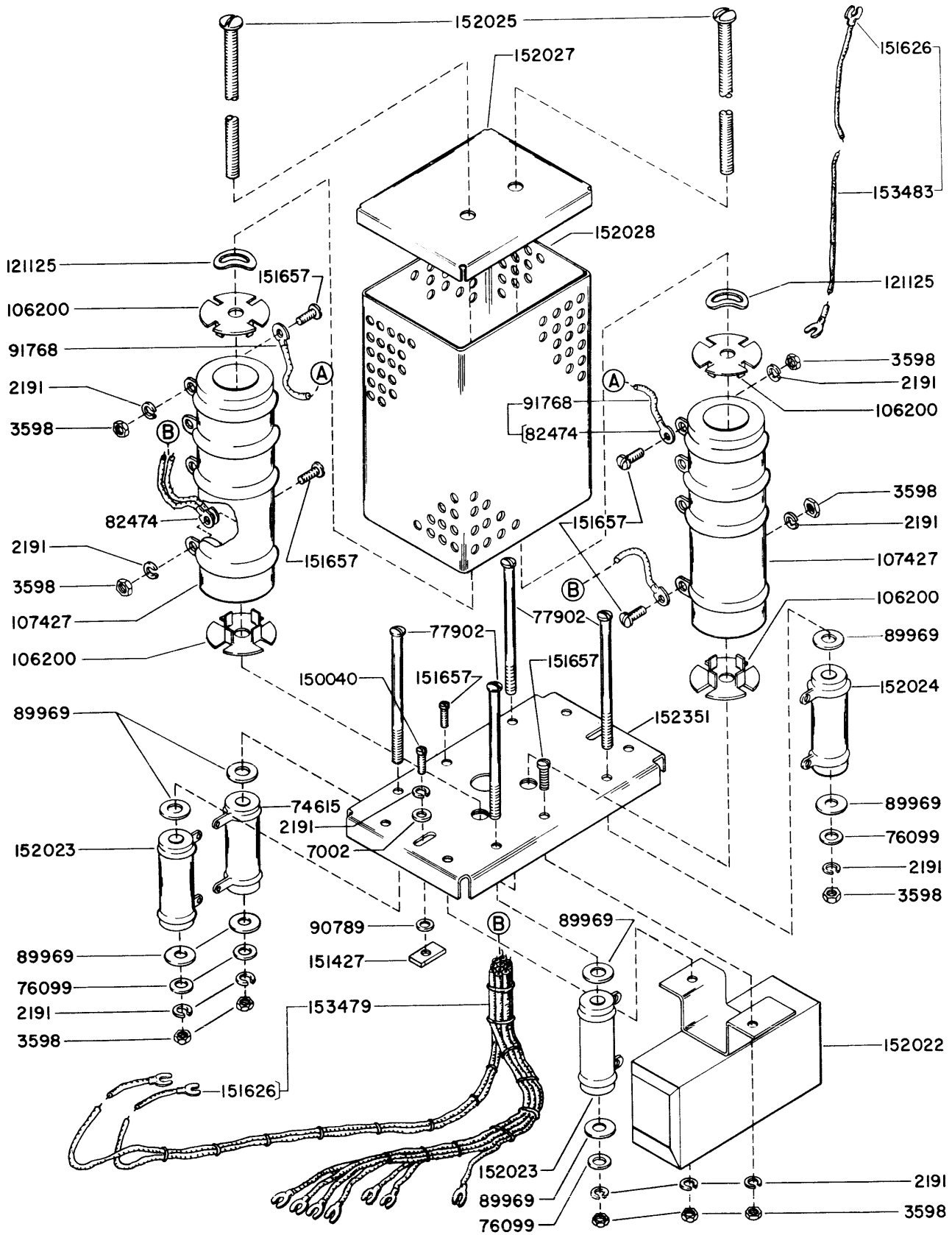


FIGURE 6-12. 152624 CAPACITOR-RESISTOR ASSEMBLY

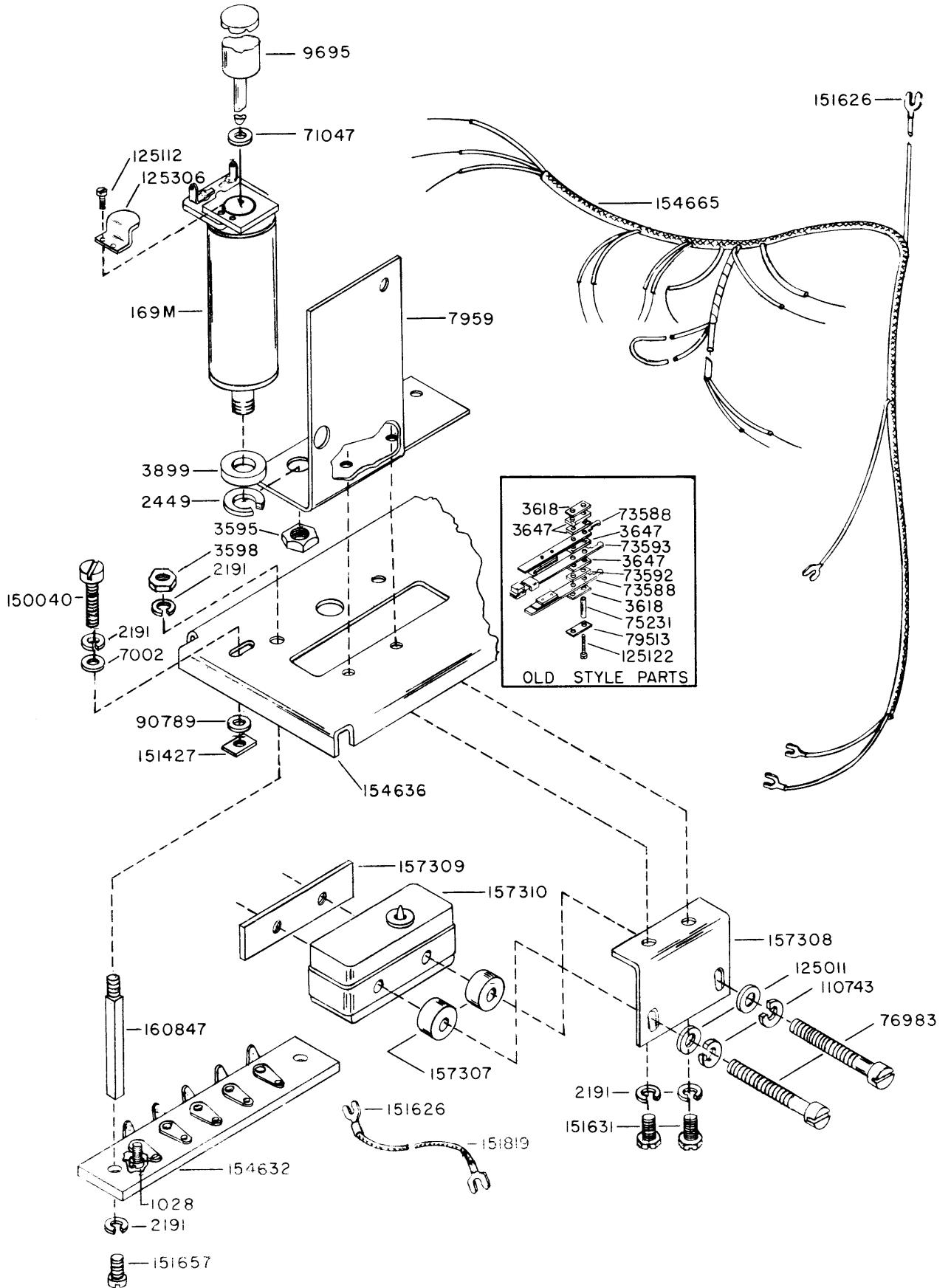
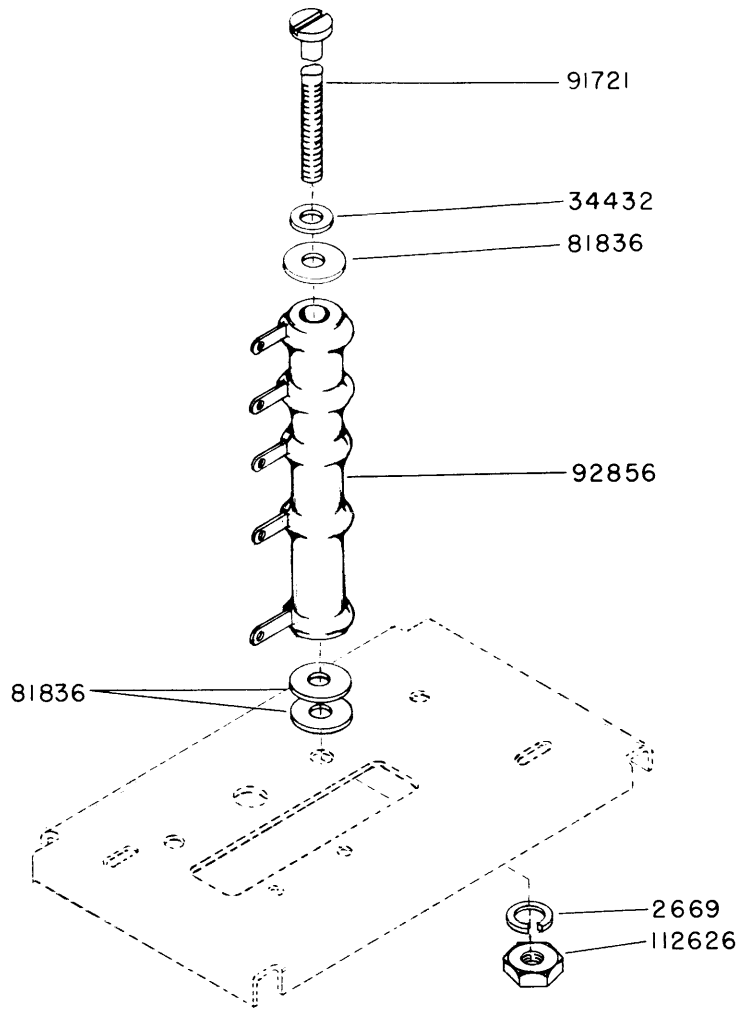
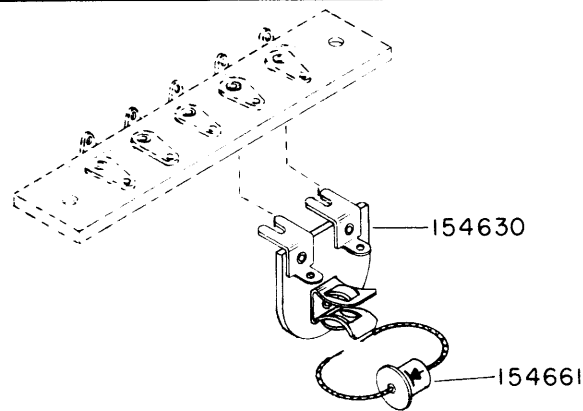


FIGURE 6-13. 152332 RELAY MOTOR CONTROL ASSEMBLY



USED WITH 152332  
SEE FIGURE 8-13

FIGURE 6-14. 93073 1500 OHM RESISTOR MODIFICATION KIT



USED WITH 152332  
SEE FIGURE 8-13

FIGURE 6-15. 152331 RECTIFIER ASSEMBLY

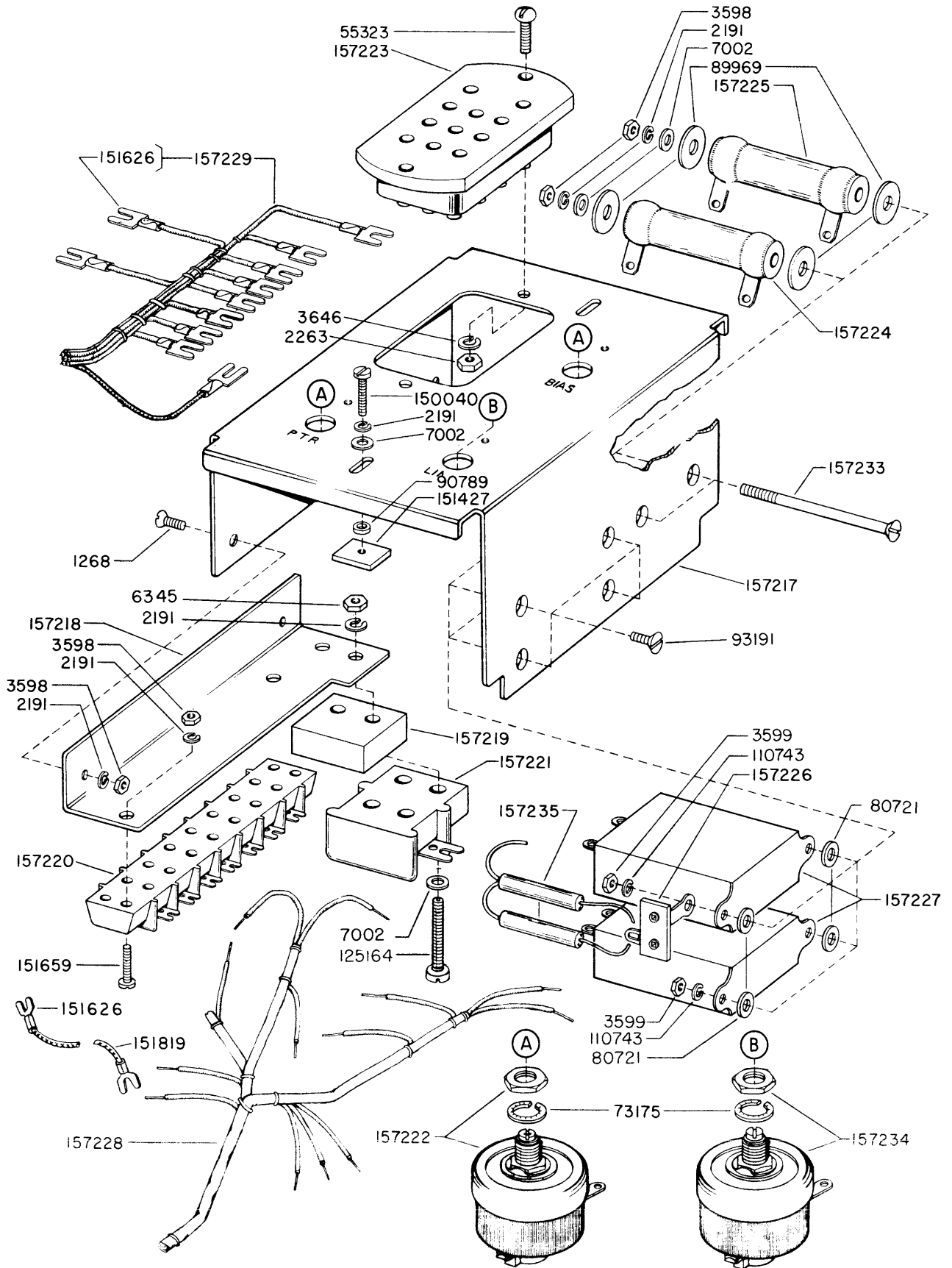


FIGURE 6-16. 157216 LINE RELAY MOUNTING ASSEMBLY

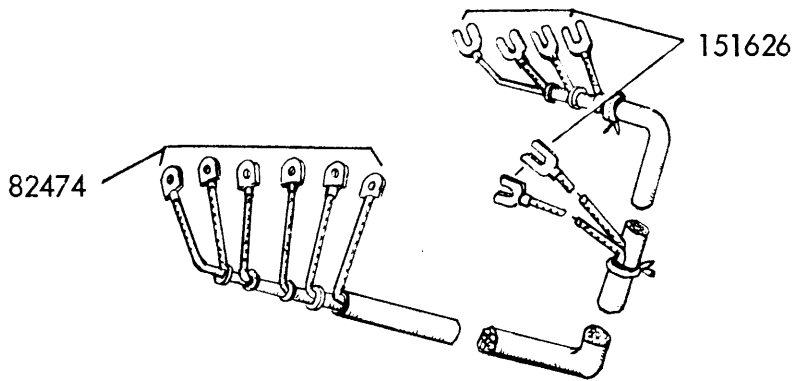


FIGURE 6-17. 160223 AUXILIARY CABLE ASSEMBLY

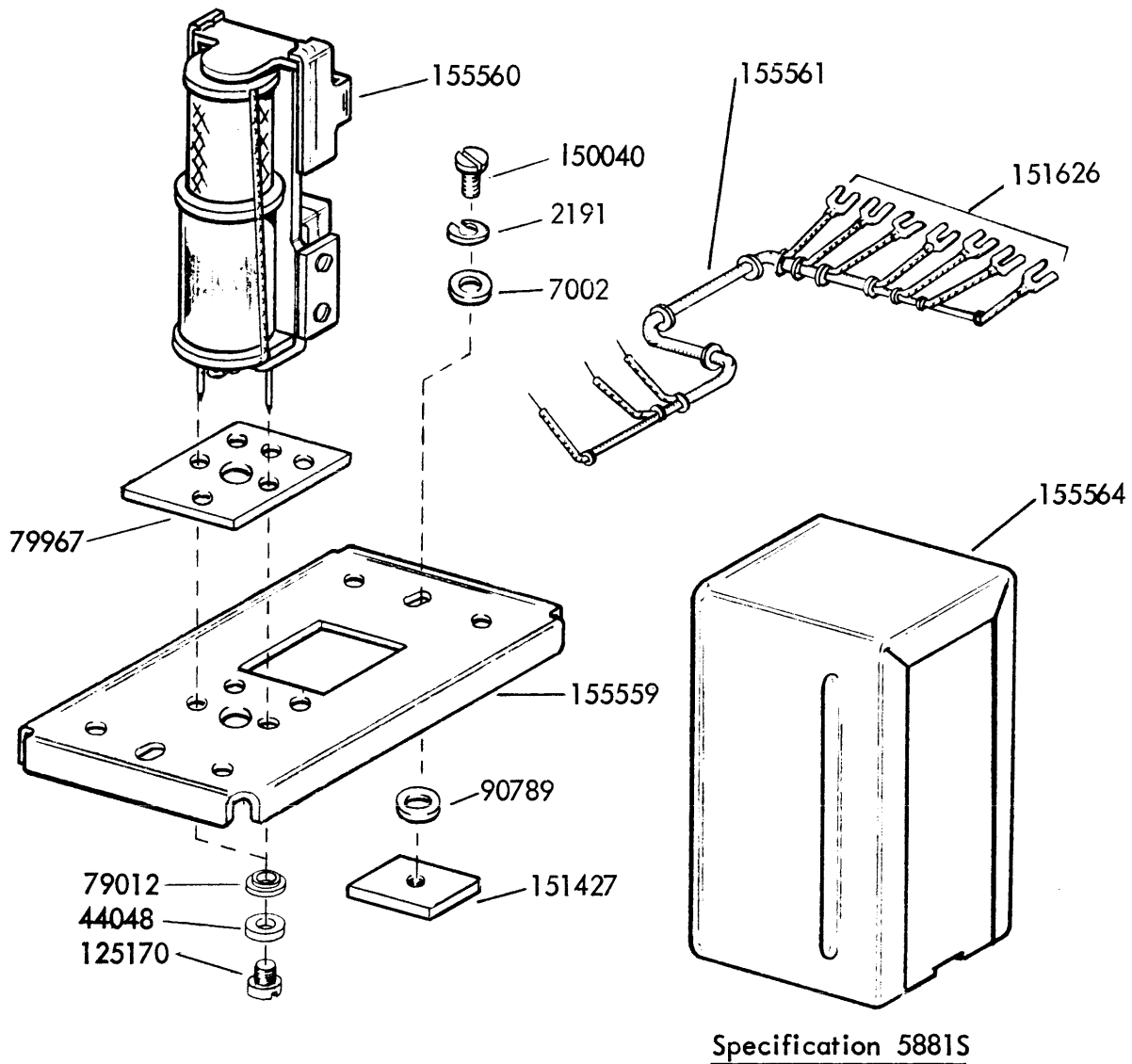
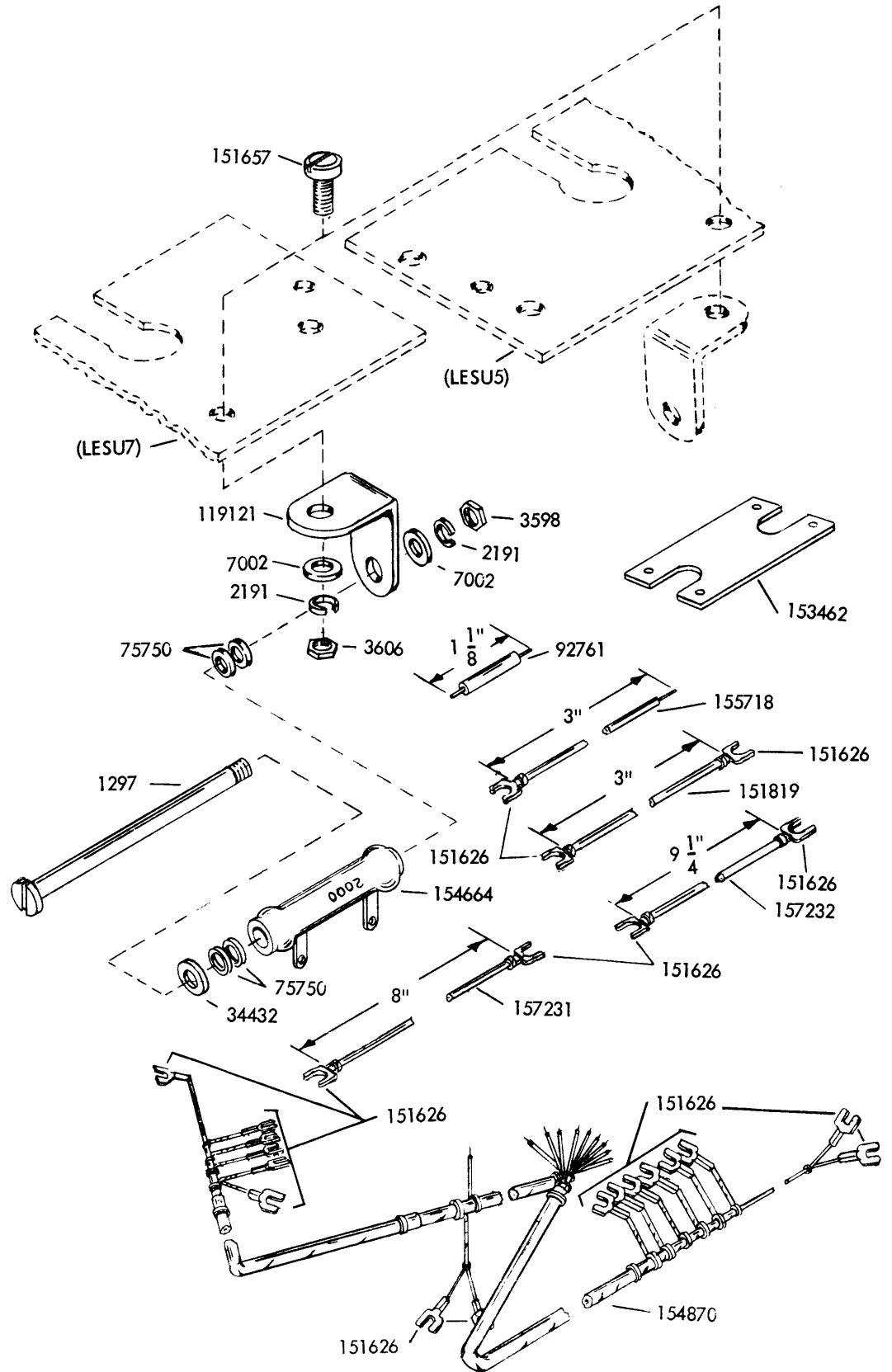


FIGURE 6-18. 15558 DC CONTROL RELAY ASSEMBLY



SPECIFICATION 5776S

FIGURE 6-19. 154747 MODIFICATION KIT TO EQUIP AN ELECTRICAL SERVICE UNIT FOR CONTINUOUS SPACING

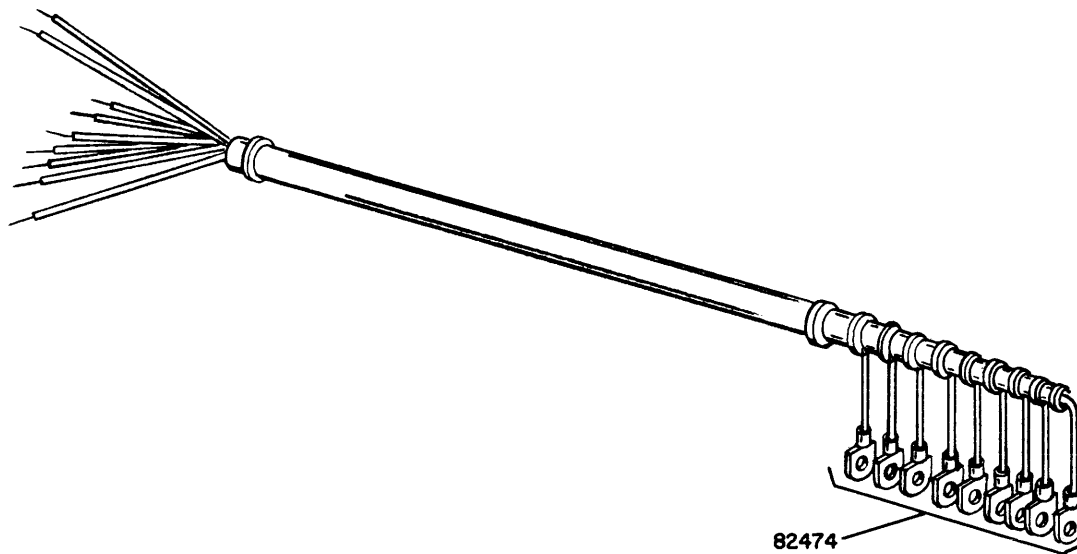
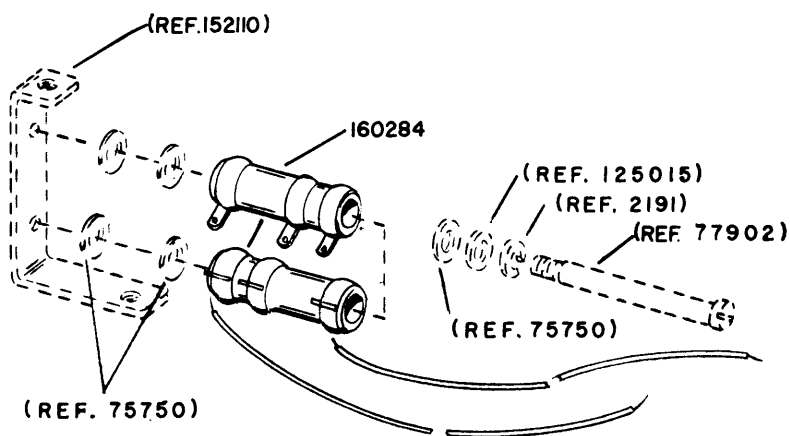


FIGURE 6-20. 155785 CABLE EXTENSION



SPECIFICATION 5664S

FIGURE 6-21. 159397 MODIFICATION KIT TO CONVERT 152623 LINE RELAY MOUNTING ASSEMBLY TO 160226 ASSEMBLY



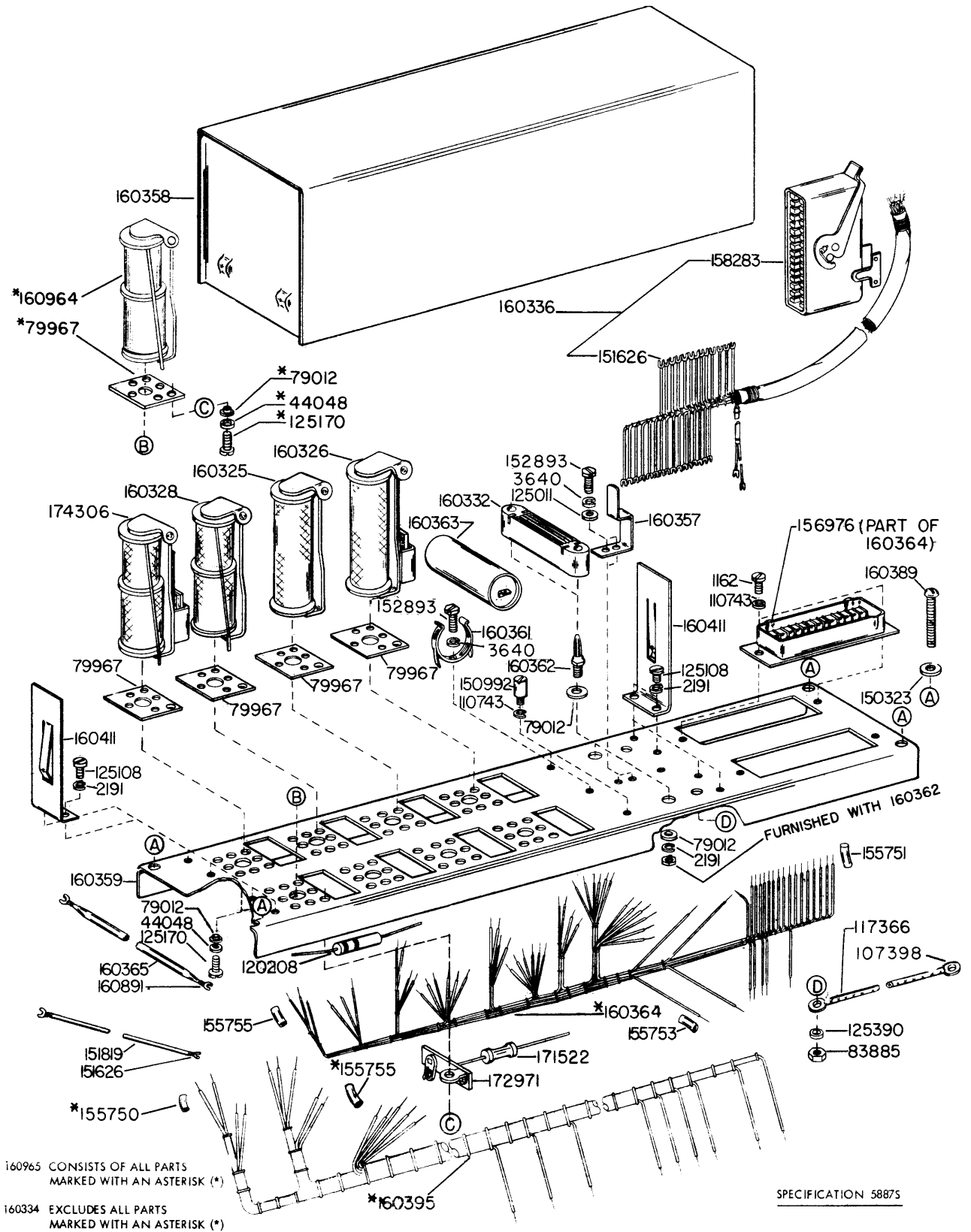


FIGURE 6-22. 160966 MODIFICATION KIT TO PROVIDE TRANSMITTER AND REPERFORATOR CONTROL

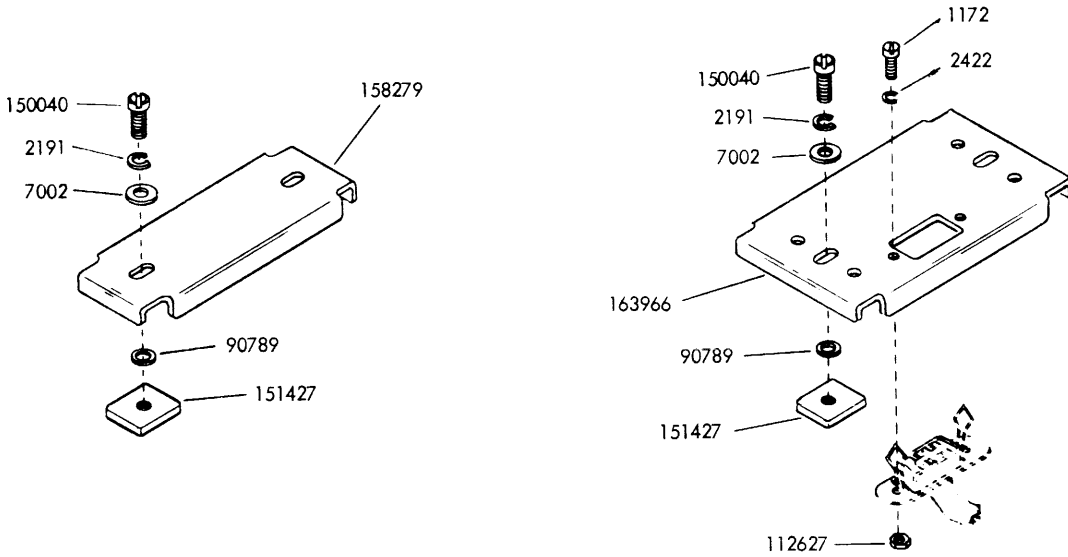
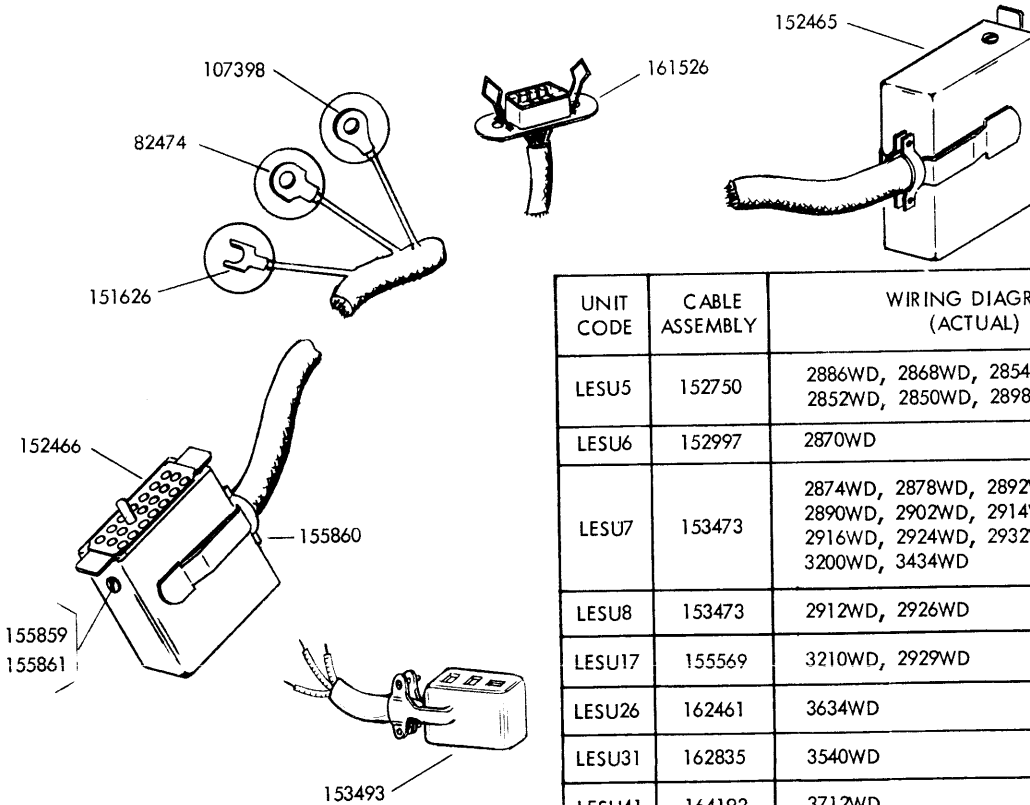


FIGURE 6-23. VARIABLE FEATURES FOR ELECTRICAL SERVICE UNIT



UNIT CODE	CABLE ASSEMBLY	WIRING DIAGRAMS (ACTUAL)
LESU5	152750	2886WD, 2868WD, 2854WD, 2860WD, 2852WD, 2850WD, 2898WD
LESU6	152997	2870WD
LESU7	153473	2874WD, 2878WD, 2892WD, 2888WD, 2890WD, 2902WD, 2914WD, 2906WD, 2916WD, 2924WD, 2932WD, 3068WD, 3200WD, 3434WD
LESU8	153473	2912WD, 2926WD
LESU17	155569	3210WD, 2929WD
LESU26	162461	3634WD
LESU31	162835	3540WD
LESU41	164192	3712WD
LESU42	163316	3716WD
LESU45	164238	3760WD
LESU46	164239	3768WD
LESU67	176681	4342WD

FIGURE 6-24. CABLE ASSEMBLY CHART

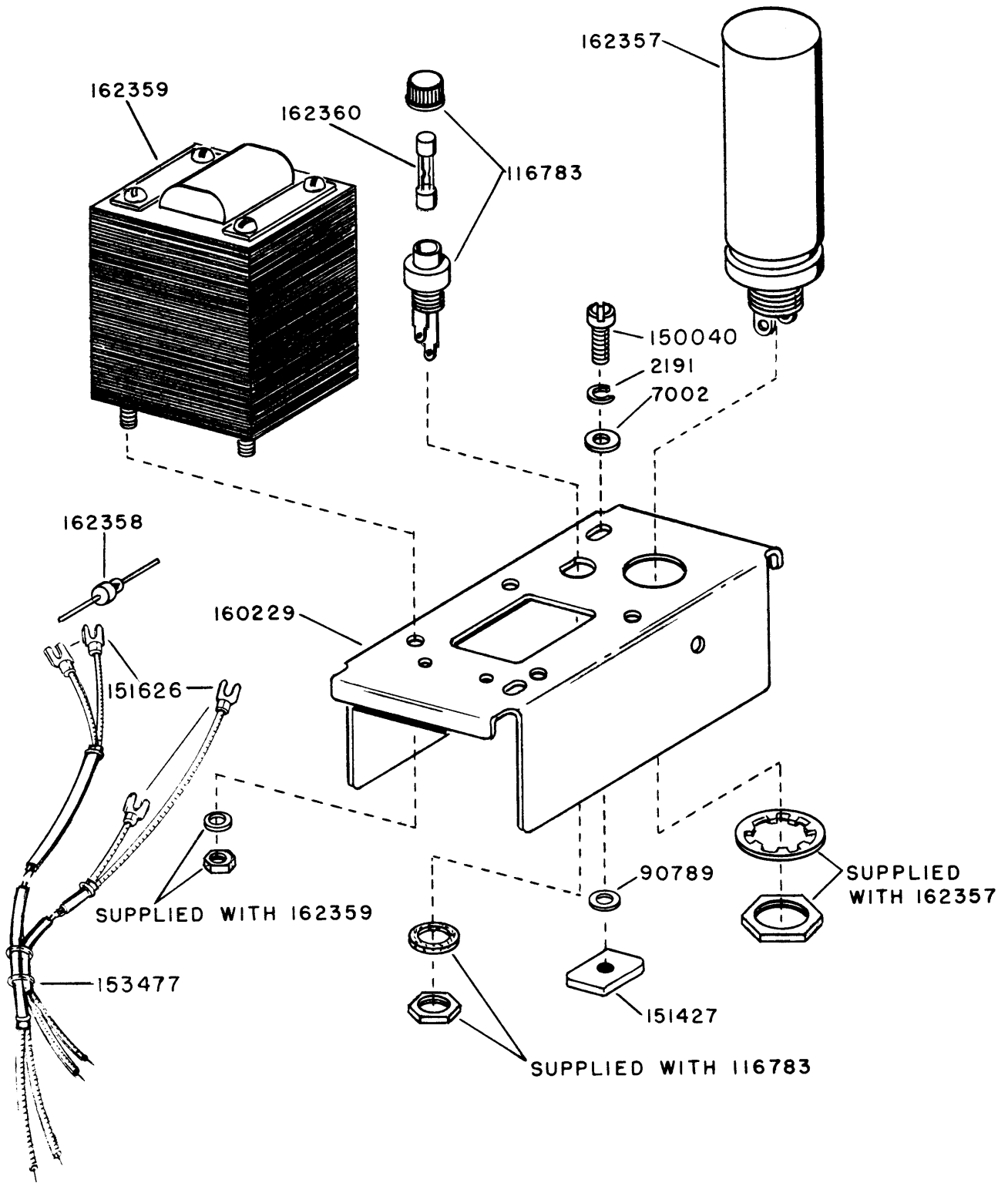


FIGURE 6-25. 162361 RECTIFIER AND CABLE ASSEMBLY (500MA)

FIGURE 6-26. 163696 AND 163697 RELAY PANEL ASSEMBLIES

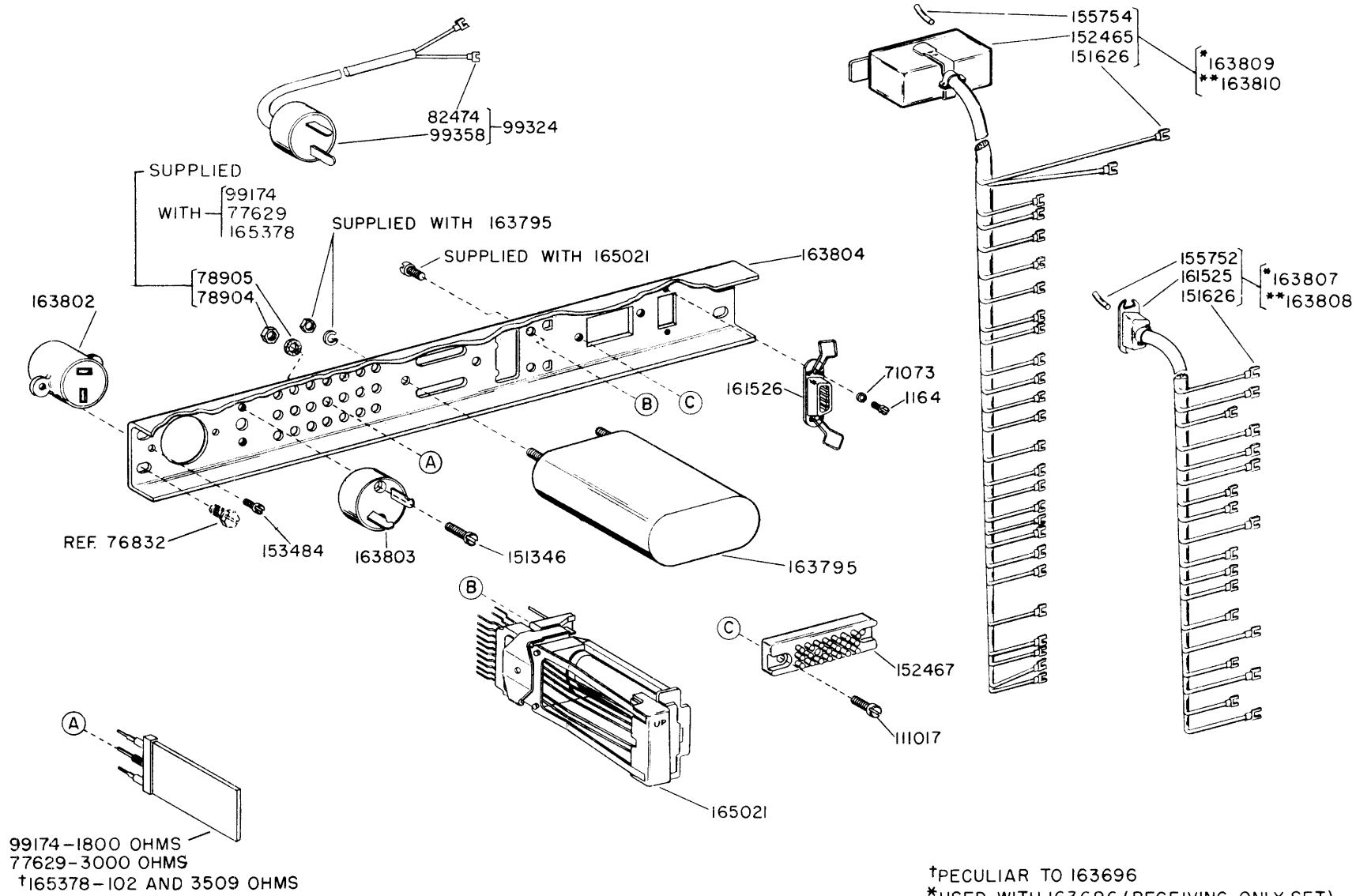
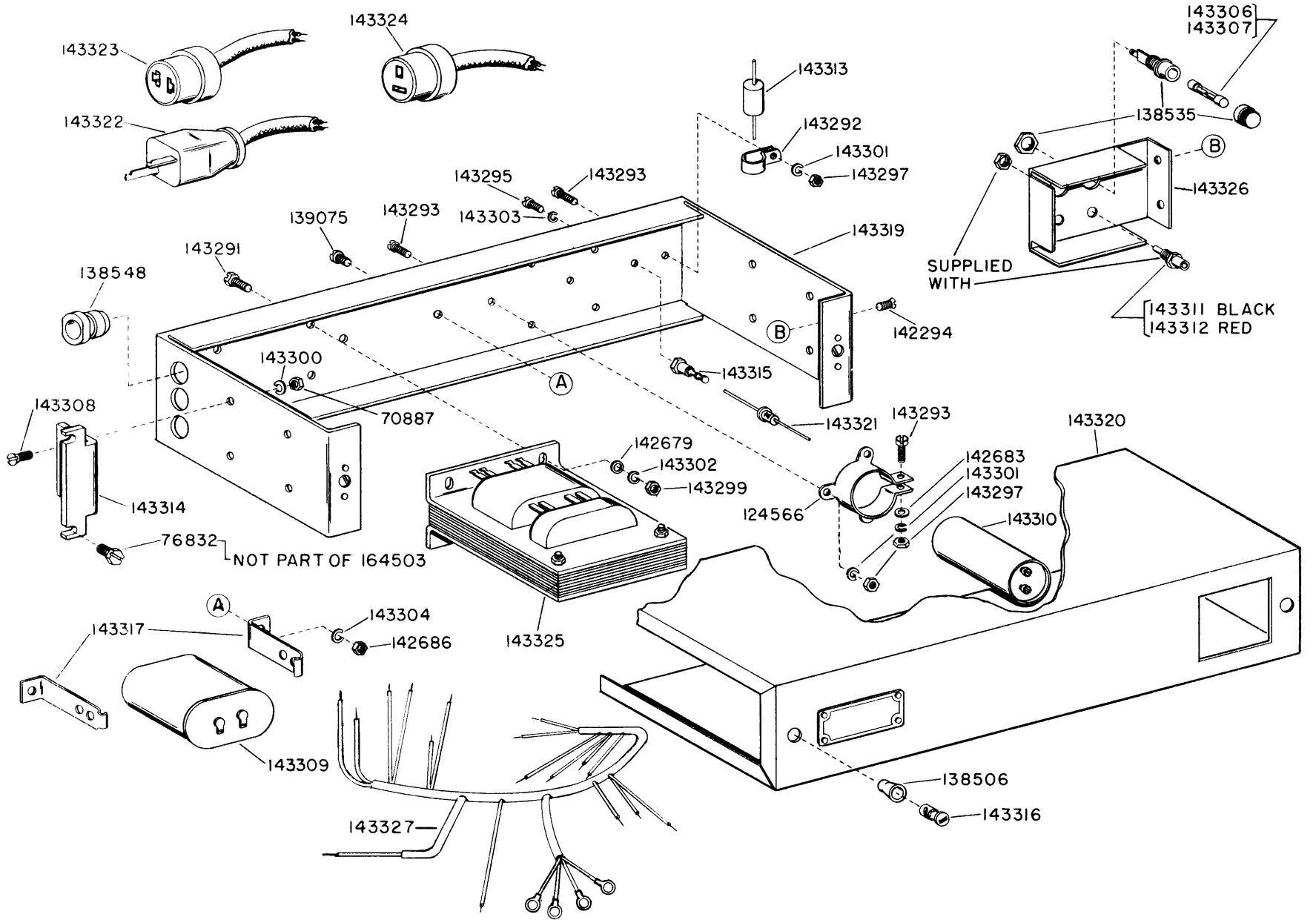


FIGURE 6-27. I64503 RECTIFIER ASSEMBLY



11498

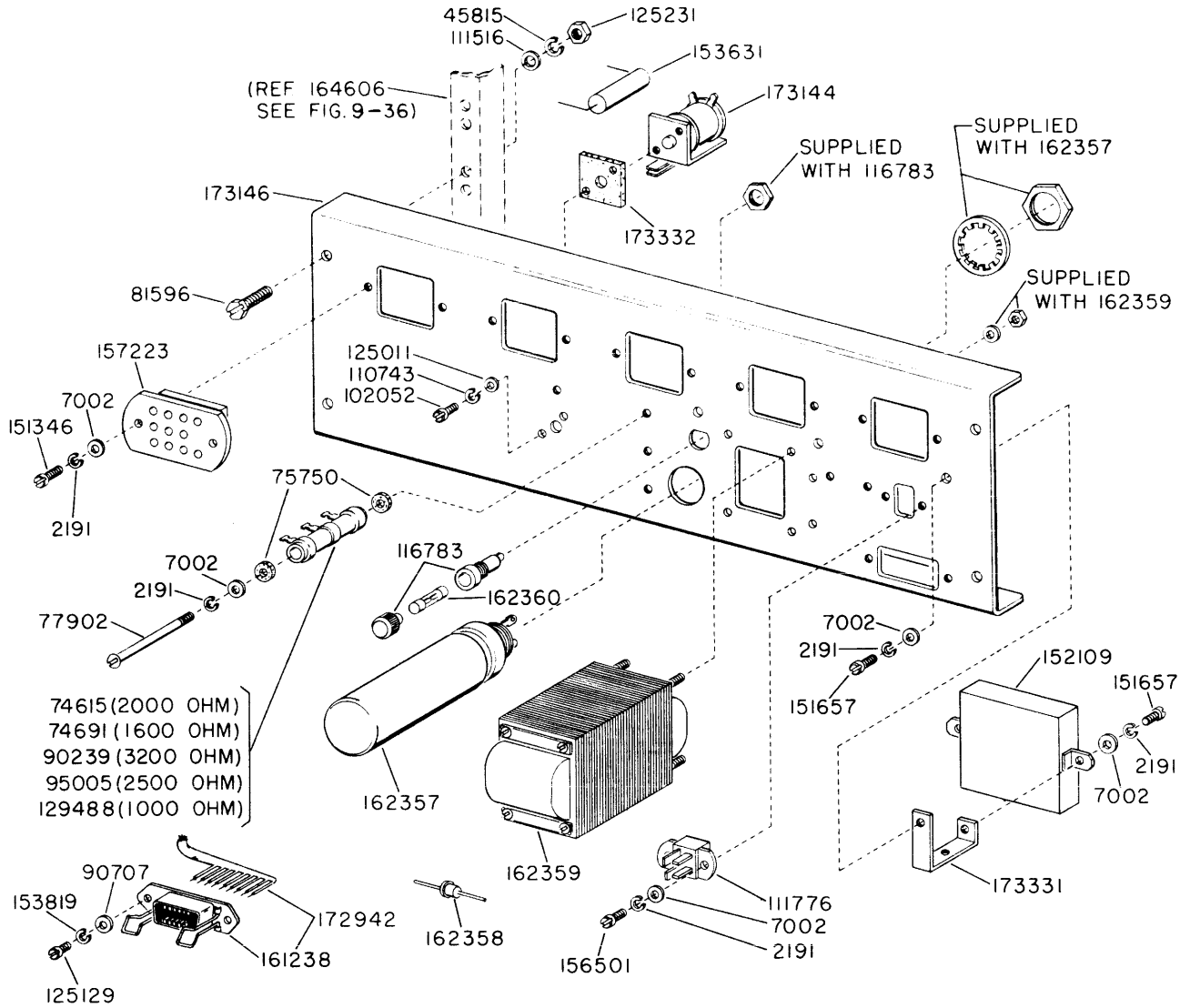


FIGURE 6-28. 164271 ELECTRICAL SERVICE ASSEMBLY

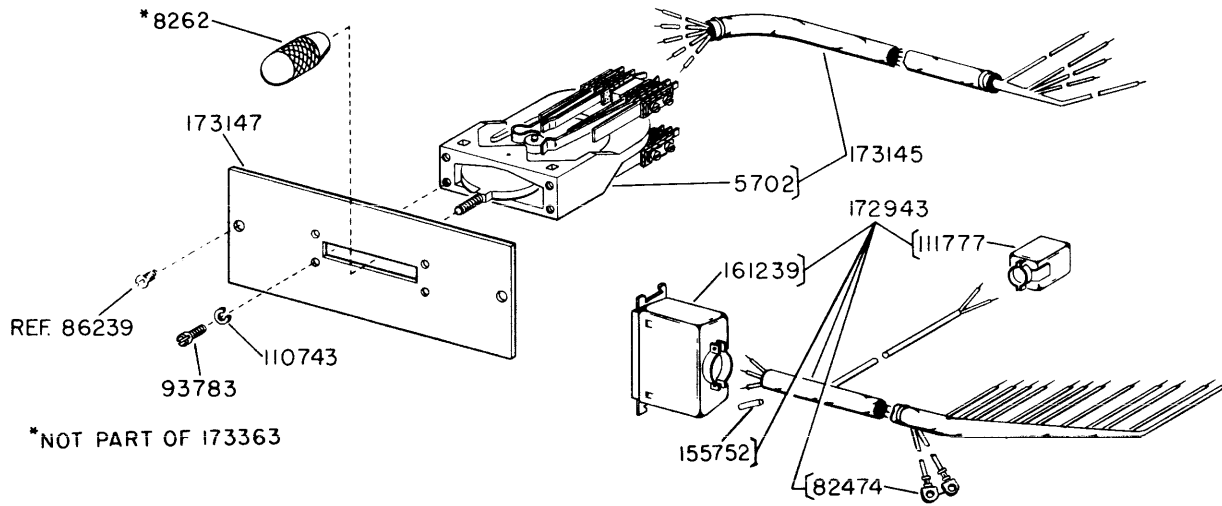
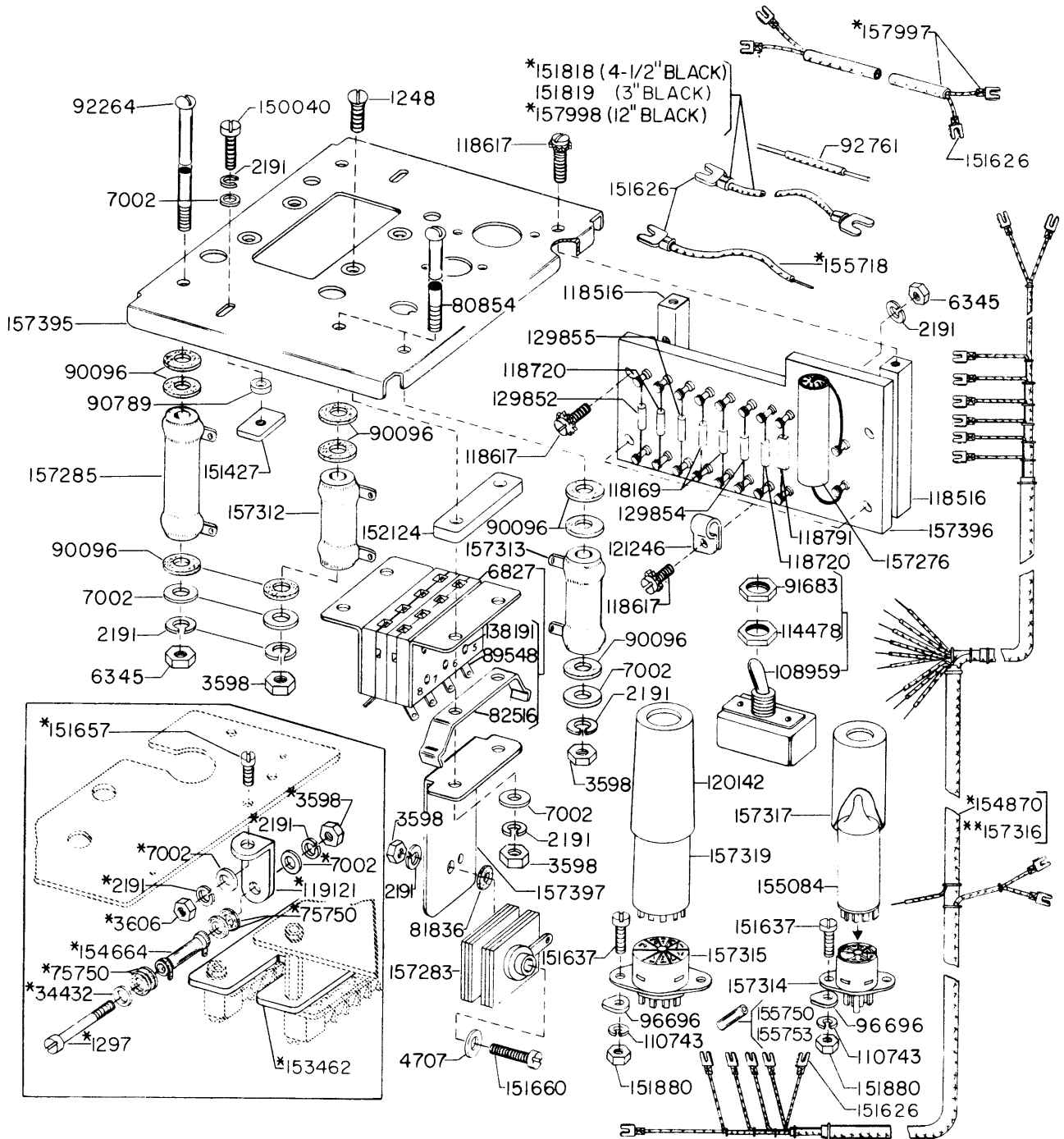


FIGURE 6-29. 173363 MODIFICATION KIT TO ADAPT A 164271 ELECTRICAL SERVICE ASSEMBLY FOR USE IN AN LBAC211\*\* CABINET



30RY LINE RELAY  
 (SEE BULLETIN 1044B FOR COMPONENTS)

\* PECULIAR TO 154732 (FOR LESU5)  
 \*\* PECULIAR TO 154779 (FOR LESU7&8)  
SPECIFICATION 5871S

FIGURE 6-30 154732 AND 154779 MODIFICATION KITS TO ADD A RELAY SHIFT UNIT  
 TO AN ELECTRICAL SERVICE UNIT

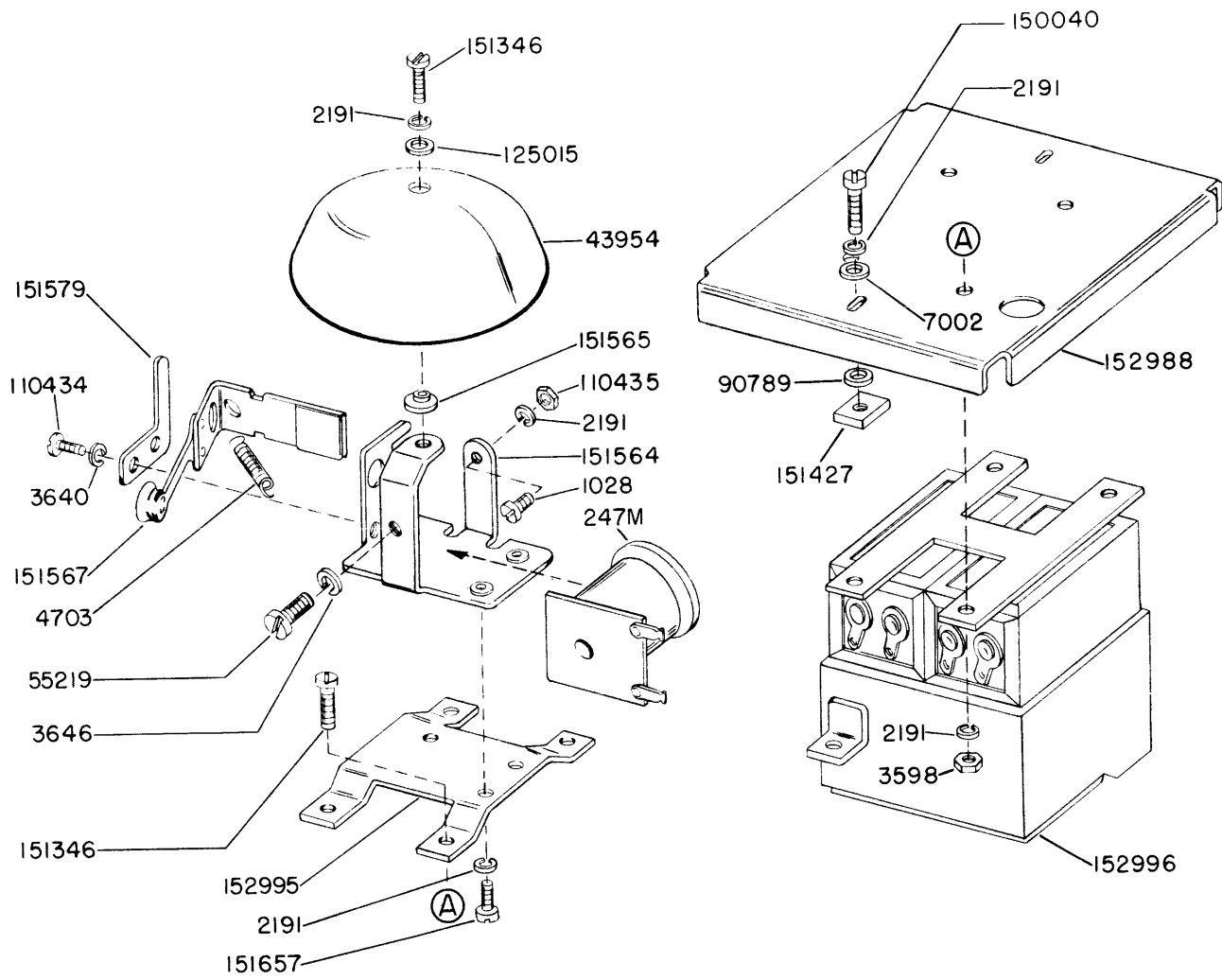


FIGURE 6-31. 152999 FILTER AND BELL ASSEMBLY



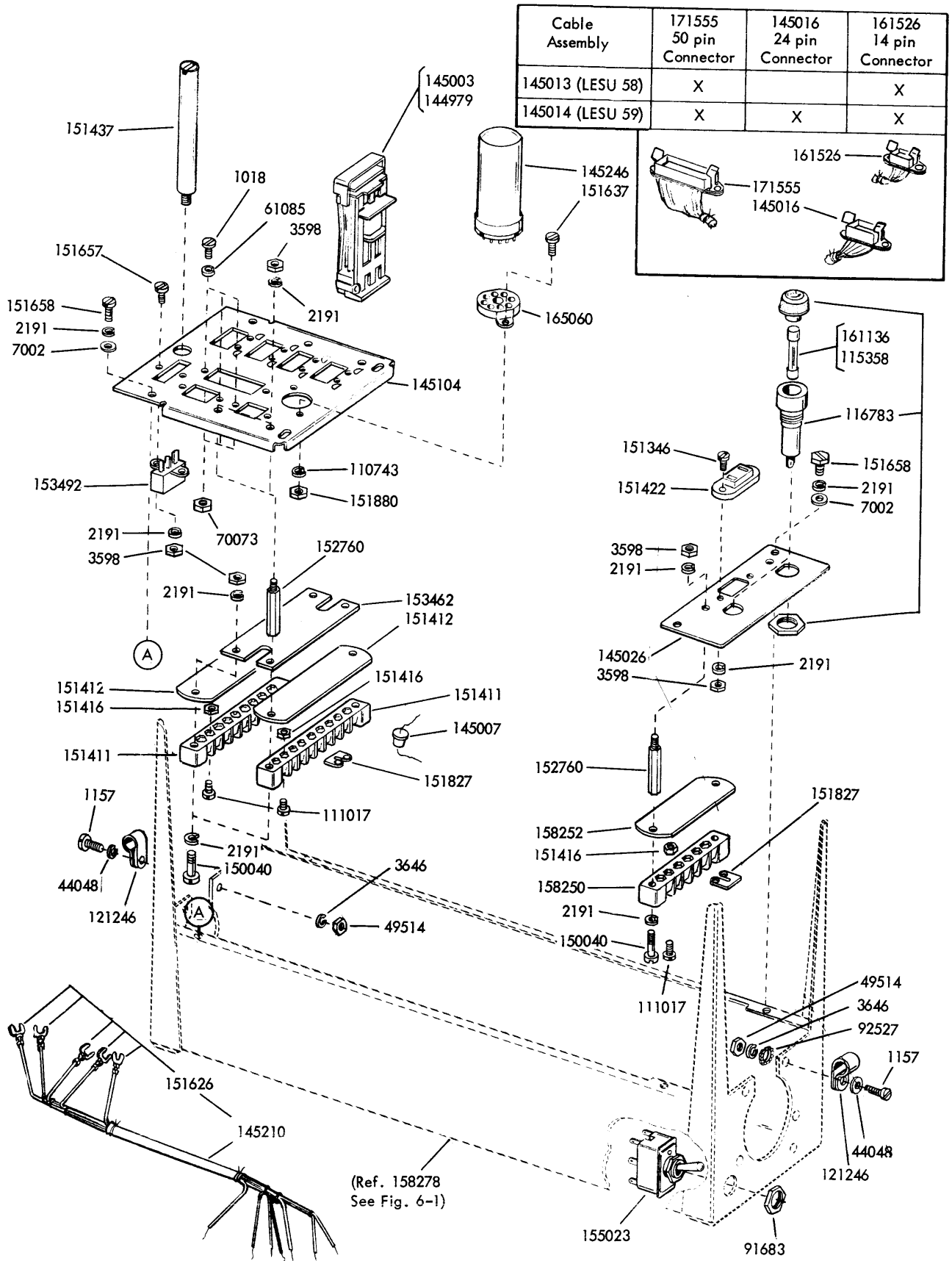
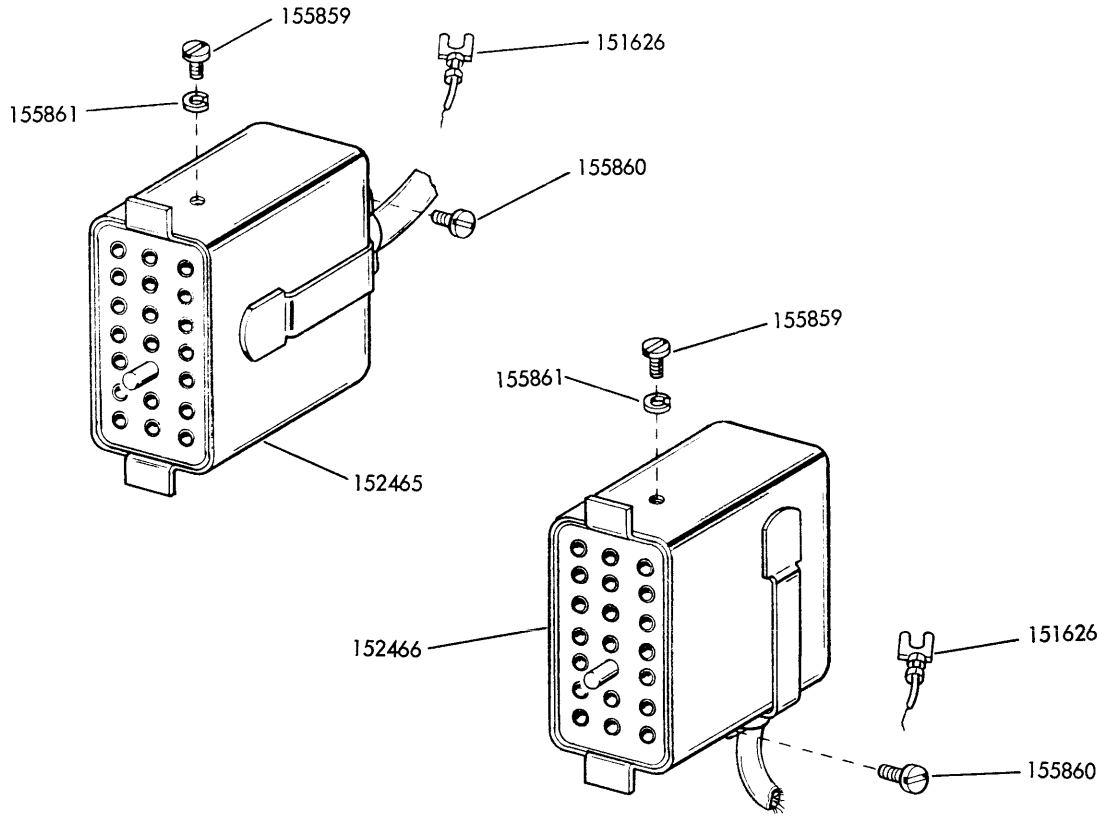


FIGURE 6-32. ELECTRICAL SERVICE UNIT

1149B



256 ACCESSORY GROUP		
CABLE ASSEMBLIES	CONNECTOR RECEPTACLE	151627 TERMINALS
145282, F	152465	(7)
145283, R	152466	(7)
145284, S	152466	(13)
145067	NONE	(20)
257 ACCESSORY GROUP		
CABLE ASSEMBLIES	CONNECTOR RECEPTACLE	151627 TERMINALS
145062, R	152466	(7)
145063, S	152466	(13)
145064, F	152465	(7)

FIGURE 6-33. ELECTRICAL SERVICE UNIT (ACCESSORY GROUPS)

1149B

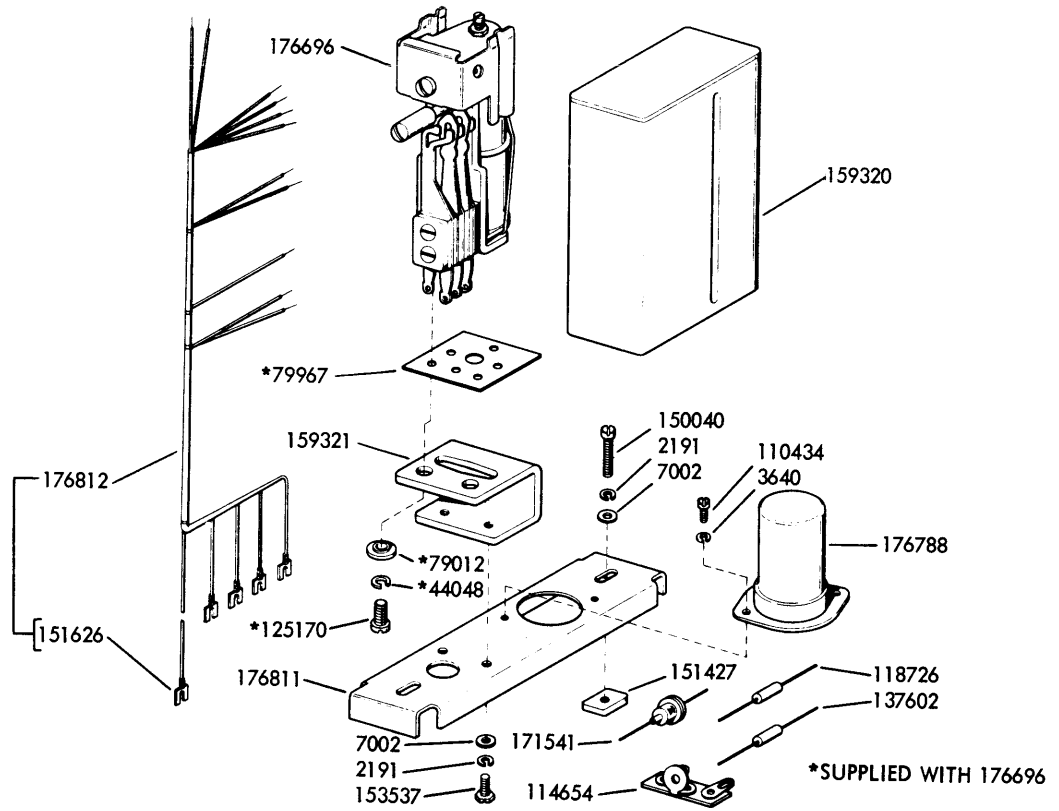


FIGURE 6-34. 176810 ANSWER-BACK CONTROL RELAY ASSEMBLY

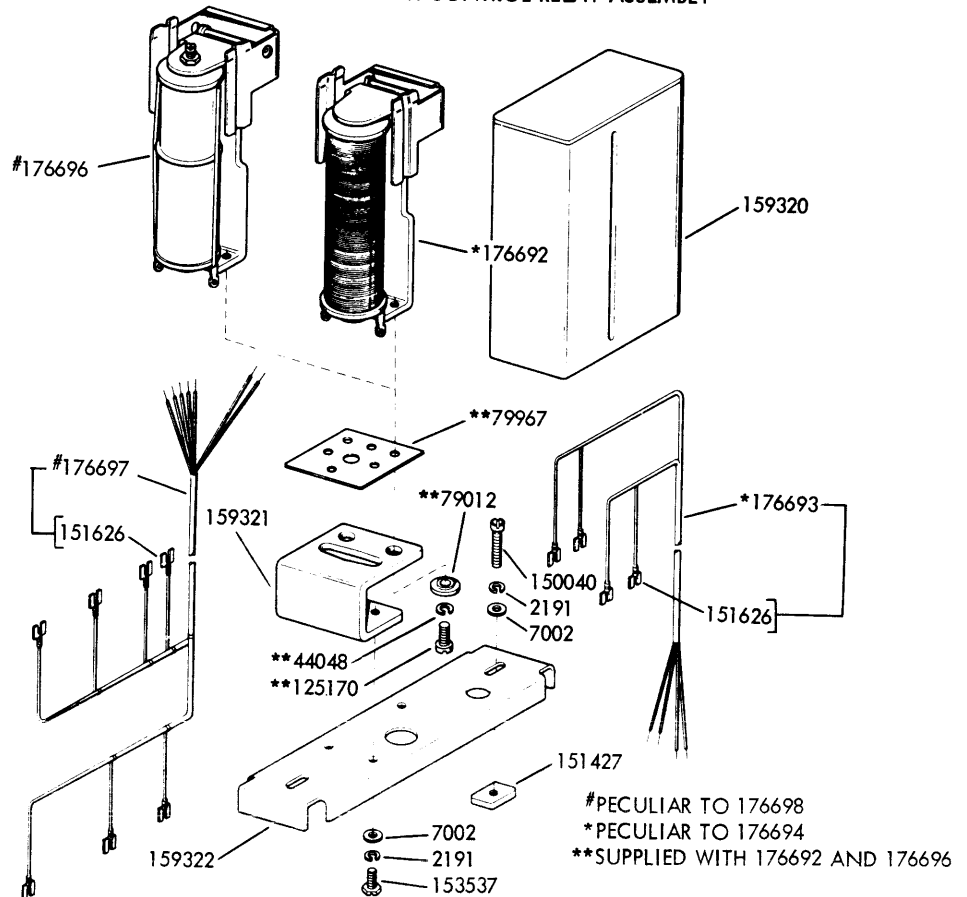


FIGURE 6-35. 176694 (MOTOR CONTROL) AND 176698 (SLOW RELEASE) RELAY ASSEMBLIES

## 1149B

## NUMERICAL INDEX - SECTION 6

Part Number	Description and Page Number	Part Number	Description and Page Number	Part Number	Description and Page Number
169M	Coil, Magnet 6-13	71073	Washer, Flat 6-22	93073	Modification Kit 6-14
247M	Coil, Magnet 6-5, 6-26	71155	Screw (6-32x1-3/16 Flat) 6-6	93191	Screw (4-40x5/16 Flat) 6-15
252M	Coil, Magnet 6-5			93783	Screw (4-36x3/16 Fil) 6-24
1018	Screw (3-48x5/16 Fil) 6-27	71646	Nut (6-32) 6-6	95005	Resistor (2500 ohms) 6-24
1028	Screw (4-40x7/32 Fil) 6-8, 6-10, 6-11, 6-13, 6-25	73175	Washer, Lock 6-13	96260BK	Wire 6-5
1038	Screw (6-40x9/32 Fil) 6-8, 6-10	73588	Spring 6-13	96696	Terminal 6-25
1093	Screw (8-32x7/16 Fil) 6-5	73592	Plate, Spring 6-13	99174	Resistor (1800 ohms) 6-22
1157	Screw (8-32x1/2 Fil) 6-2, 6-27	73593	Spring, Contact 6-13	99324	Cord Assembly 6-22
1162	Screw (4-40x1/4 Fil) 6-10, 6-19	74614	Resistor (2600 ohms) 6-7, 6-8	99358	Connector, Plug (2 Pt) 6-22
1164	Screw (2-56x3/16 Fil) 6-22	74615	Resistor (2000 ohms) 6-11, 6-12, 6-24	102052	Screw (4-40x9/32 Fil) 6-24
1172	Screw (2-56x5/16 Fil) 6-20	74691	Resistor (1600 ohms) 6-24	106200	Washer, Centering 6-11, 6-12
1248	Screw (6-40x7/16 Flat) 6-7, 6-8, 6-25	74821	Resistor (2810 ohms) 6-7, 6-8	107116	Washer, Lock 6-4
1268	Screw (6-40x5/16 Flat) 6-15	74882	Spring 6-5	107393	Switch, Toggle 6-2
1297	Screw (6-40x2-7/16 Fil) 6-7, 6-9, 6-17, 6-25	75231	Bushing 6-13	107398	Terminal 6-2, 6-3, 6-19, 6-20
2034	Washer, Flat 6-5	75750	Washer, Insulating 6-7, 6-8, 6-9, 6-10, 6-11, 6-17, 6-18, 6-24, 6-25	107427	Resistor (15-5-5 ohms) 6-11, 6-12
2191	Washer, Lock (SEV.)	76099	Washer, Flat 6-3, 6-9, 6-10, 6-11, 6-12	108959	Switch, Toggle 6-25
2201	Nut (5/16-32 Hex) 6-5	76832	Screw (12-24x5/8 Hex) 6-22, 6-23	110434	Screw (4-40x3/16 Fil) 6-26, 6-29
2263	Nut (8-32 Hex) 6-15	76983	Screw (4-40x1-1/4 Fil) 6-13	110435	Nut (4-40 Hex) 6-5, 6-26
2422	Washer, Lock 6-20	77629	Resistor (3000 ohms) 6-22	110743	Washer, Lock 6-10, 6-11, 6-13, 6-15, 6-19, 6-24, 6-25, 6-27
2449	Washer, Lock 6-13	77902	Screw (6-40x2-3/8 Rd) 6-8, 6-10, 6-11, 6-12, 6-18, 6-24	111017	Screw (6-40x5/16 Fil) 6-2, 6-3, 6-27
2669	Washer, Lock 6-4, 6-14	78904	Nut (8-32 Hex) 6-22	111516	Washer, Flat 6-24
3438	Washer, Flat 6-7, 6-9, 6-10	78905	Washer, Flat 6-22	111776	Connector, Plug (4 Pt) 6-24
3595	Nut (1/4-32) 6-13	79012	Washer, Insulating 6-16, 6-19, 6-29	111777	Connector, Receptacle (4 Pt) 6-24
3598	Nut (6-40 Hex) (SEV.)	79513	Plate 6-13	111970	Key, Line Test 6-9, 6-10
3599	Nut (4-40 Hex) (SEV.)	79967	Insulator 6-16, 6-19	111971	Knob 6-9, 6-10
3606	Nut (6-40 Hex) 6-2, 6-3, 6-25	80721	Washer, Flat 6-15	112626	Nut (10-32 Hex) 6-4, 6-14, 6-15
3618	Insulator 6-13	80854	Screw (6-40x1-7/16 Fil) 6-3, 6-5	112627	Nut (2-56 Hex) 6-20
3640	Washer, Lock 6-5, 6-19, 6-25, 6-29	81596	Screw (10-32x1-3/8 Hex) 6-24	114478	Nut (15/32-32 Hex) 6-25
3646	Washer, Lock 6-2, 6-5, 6-7, 6-15, 6-26, 6-27	81775	Resistor (8000 ohms) 6-7	114654	Strip, Terminal 6-29
3647	Insulator 6-13	81824	Nut (4-40 Hex) 6-11	115358	Fuse (1 amp) 6-27
3650	Washer, Flat 6-11	81836	Washer, Fiber 6-4, 6-14, 6-25	116783	Holder, Fuse 6-2, 6-3, 6-21, 6-24, 6-27
3870	Spring 6-5	82474	Terminal 6-3, 6-4, 6-11, 6-12, 6-16, 6-18, 6-20, 6-22, 6-24	117366	Jumper 6-19
3899	Spacer 6-13	82516	Spring 6-7, 6-8, 6-25	118169	Resistor (1 meg) 6-25
4703	Spring 6-26	82870	Resistor (6300 ohms) 6-9	118516	Post 6-25
4707	Washer, Flat 6-25	83885	Nut (6-32 Hex) 6-19	118617	Screw w/Washer (6-32x3/8 Fil) 6-25
5702	Switch, Key 6-24	89548	Spring, Contact 6-7, 6-8, 6-25	118720	Resistor (.1 meg) 6-25
5816	Washer, Fiber 6-5	89969	Washer, Insulating 6-3, 6-11, 6-12, 6-15	118726	Resistor (820 ohms) 6-29
6345	Nut (6-32 Hex) 6-15, 6-25	90096	Washer, Insulating 6-25	119121	Bracket 6-17, 6-25
6827	Block, Connecting 6-7, 6-8, 6-25	90239	Resistor (3200 ohms) 6-24	120142	Shield, Tube 6-25
7002	Washer, Flat (SEV.)	90707	Washer, Flat 6-24	120195	Rectifier 6-6
7603	Spring 6-5	90789	Washer, Flat (SEV.)	120208	Resistor (22 ohms) 6-19
7959	Bracket, Magnet 6-13	91683	Nut (15/32-32 Hex) 6-2, 6-3, 6-25, 6-27	121125	Washer, Spring 6-5, 6-11, 6-12
8262	Knob 6-24	91721	Screw (10-32x3-3/4 Fil) 6-4, 6-14	121245	Clamp, Cable (5/16" I.D.) 6-5
9695	Plunger 6-13	91768	Jumper 6-11, 6-12	121246	Clamp, Cable (3/8" I.D.) 6-25, 6-27
34432	Washer, Flat 6-4, 6-14, 6-16, 6-25	92260	Washer, Lock 6-6	121247	Clamp, Cable (7/16" I.D.) 6-3
43954	Bell, Signal 6-26	92264	Screw (6-32x2-1/4 Rd) 6-25	121248	Clamp, Cable (1/2" I.D.) 6-2
44048	Washer, Flat 6-2, 6-5, 6-16, 6-19, 6-27, 6-29	92527	Washer, Lock 6-2, 6-27	121249	Clamp, Cable (5/8" I.D.) 6-2
45815	Washer, Lock 6-24	92761	Strap 6-17, 6-25	124566	Bracket 6-23
49514	Nut (8-32 Hex) 6-2, 6-27	92856	Resistor (1500 ohms) 6-4, 6-14	125011	Washer, Flat 6-10, 6-13, 6-19, 6-24
55219	Screw (8-32x3/8 Fil) 6-25				
55323	Screw (8-32x1/2 Rd) 6-15				
61085	Washer, Lock 6-27				
70073	Nut (3-48 Hex) 6-27				
70887	Nut (10-24 Hex) 6-23				
71047	Washer, Flat 6-13				

## NUMERICAL INDEX - SECTION 6 (Continued)

Part Number	Description and Page Number	Part Number	Description and Page Number	Part Number	Description and Page Number
125015	Washer, Flat 6-6, 6-8, 6-18, 6-26	145013	Cable Assembly 6-27	151660	Screw (6-40x7/8 Fil) 6-25
125108	Screw (6-32x3/8 Fil) 6-19	145014	Cable Assembly 6-27	151801	Bushing, Clamp 6-3
125112	Screw (2-56x1/8 Fil) 6-13	145016	Connector, Receptacle (24 Pt) 6-27	151808	Relay 6-2
125122	Screw (2-56x3/4 Fil) 6-13	145026	Plate, Right Mounting 6-27	151813	Cover 6-2
125129	Screw (3-48x3/8 Fil) 6-24	145062	Cable Assembly, R 6-28	151814	Bracket 6-2
125164	Screw (6-32x1 Fil) 6-15	145063	Cable Assembly, S 6-28	151818	Jumper 6-4, 6-7, 6-25
125170	Screw (8-32x5/16 Fil) 6-16, 6-19, 6-29	145064	Cable Assembly, F 6-28	151819	Jumper 6-4, 6-5, 6-8, 6-10, 6-13, 6-15, 6-17, 6-19, 6-25
125231	Nut (10-32 Hex) 6-24	145067	Cable Assembly 6-28	151822	Mounting Assembly 6-7
125306	Stop, Magnet Plunger 6-13	145104	Plate, Mounting 6-27	151825	Cable Assembly 6-6
125390	Washer, Flat 6-5, 6-19	145210	Cable Assembly 6-27	151826	Cable Assembly 6-7
129488	Resistor (1000 ohms) 6-24	145246	Relay 6-27	151827	Strap, Terminal 6-3, 6-27
129852	Resistor (2200 ohms) 6-25	145282	Cable Assembly, F 6-28	151880	Nut (4-40 Hex) 6-25, 6-27
129854	Resistor (10,000 ohms) 6-25	145283	Cable Assembly, R 6-28	151913	Plate, Mounting 6-6
129855	Resistor (51,000 ohms) 6-25	145284	Cable Assembly, S 6-28	151914	Capacitor 6-6
129919	Fuse (4 amp) 6-3	150040	Screw (6-40x5/8 Fil) 6-2, 6-3, 6-4, 6-5, 6-6, 6-7, 6-8, 6-9, 6-11, 6-12, 6-13, 6-15, 6-16, 6-20, 6-21, 6-25, 6-26, 6-27	151916	Transformer 6-6
131045	Screw (6-40x1-5/16 Fil) 6-13	150323	Washer, Flat 6-19	151995	Modification Kit 6-4
137602	Resistor (470 ohms) 6-29	150992	Stud 6-19	151996	Cable Assembly 6-4
138191	Screw (3-48x1 Rd) 6-7, 6-8, 6-25	151346	Screw (6-40x3/8 Fil) 6-2, 6-3, 6-24, 6-27	151999	Cable Assembly 6-6
138506	Grommet 6-23	151400	Control Assembly 6-5	152021	Capacitor-Resistor Assembly 6-11
138535	Holder, Fuse 6-23	151401	Base 6-5	152022	Suppressor, Electrical Noise 6-11, 6-12
138548	Grommet 6-23	151402	Core 6-5	152023	Resistor (400 ohms) 6-11, 6-12
139075	Screw (8-32x1/4 Fil) 6-23	151403	Frame 6-5	152024	Resistor (1 ohm) 6-11, 6-12
139777	Screw (3-56x1/4 Flat) 6-9, 6-10	151406	Plate 6-5	152025	Bolt (1/4-20x5 Rd) 6-11, 6-12
142294	Screw (8-32x3/8 Flat) 6-23	151407	Collar 6-5	152026	Cable Assembly 6-11
142679	Washer, Flat 6-23	151408	Lever 6-5	152027	Plate 6-11, 6-12
142683	Washer, Flat 6-23	151409	Armature 6-5	152028	Guard 6-11, 6-12
142686	Nut (8-32 Hex) 6-23	151410	Clip, Retaining 6-5	152030	Cable Assembly 6-11
143291	Screw (1/4-20x5/8 Hex) 6-23	151411	Block, Terminal 6-2, 6-3, 6-27	152108	Plate, Relay 6-7
143292	Clamp 6-23	151412	Insulator 6-2, 6-3, 6-27	152109	Filter 6-7, 6-8, 6-24
143293	Screw (6-32x1/4 Fil) 6-23	151414	Switch, Sensitive 6-5	152110	Bracket 6-7, 6-8, 6-18
143295	Screw (4-40x1/4 Rd) 6-23	151416	Nut (6-40 Hex) 6-2, 6-3, 6-27	152123	Cable Assembly 6-7
143297	Nut (6-32 Hex) 6-23	151417	Cable Assembly 6-5	152124	Spacer 6-7, 6-8, 6-25
143299	Nut (1/4-20 Hex) 6-23	151418	Fuse (10 amp) 6-2, 6-3	152330	Modification Kit 6-4
143300	Washer, Lock 6-23	151421	Plate 6-2	152331	Rectifier Assembly 6-14
143301	Washer, Lock 6-23	151422	Connector, Receptacle (2 Pt) 6-2, 6-3, 6-27	152332	Control Assembly 6-13, 6-14
143302	Washer, Lock 6-23	151423	Plate 6-2	152351	Plate 6-11, 6-12
143303	Washer, Lock 6-22, 6-23	151427	Plate, Clamp (SEV.)	152465	Connector, Receptacle (20 Pt) 6-20, 6-22, 6-28
143304	Washer, Lock 6-23	151432	Armature 6-5	152466	Connector, Receptacle (20 Pt) 6-20, 6-28
143306	Fuse (1 amp) 6-23	151437	Stud 6-2, 6-4, 6-27	152467	Connector, Plug (20 Pt) 6-22
143307	Fuse (.6 amp) 6-23	151440	Stud 6-5	152623	Mounting Assembly 6-8, 6-18
143308	Screw (10-24x5/8 Flat) 6-23	151441	Plate 6-4	152624	Capacitor-Resistor Assembly 6-12
143309	Capacitor (2.75 MFD) 6-23	151564	Bracket 6-26	152625	Key Assembly 6-10
143310	Capacitor (1250 MFD) 6-23	151565	Bushing 6-26	152744	Key Assembly 6-9
143311	Jack (Black) 6-23	151567	Armature 6-26	152745	Bracket 6-9, 6-10
143312	Jack (Red) 6-23	151579	Plate 6-26	152746	Cable Assembly 6-9
143313	Resistor (6000 ohms) 6-23	151618	Screw (6-40x7/16 Fil) 6-2, 6-3, 6-4	152750	Cable Assembly 6-20
143314	Bracket 6-23	151626	Terminal (SEV.)	152753	Jumper 6-4
143315	Terminal 6-23	151630	Screw (6-40x1/2 Hex) 6-5	152754	Jumper 6-4
143316	Stud 6-23	151631	Screw (6-40x5/16 Hex) 6-13	152755	Strap, Terminal 6-2
143317	Bracket 6-23	151632	Screw (6-40x3/8 Hex) 6-5	152757	Modification Kit 6-4
143319	Chassis 6-23	151637	Screw (4-40x1/4 Fil) 6-10, 6-25, 6-27	152760	Stud 6-2, 6-3, 6-27
143320	Cover 6-23	151657	Screw (6-40x1/4 Fil) 6-2, 6-7, 6-8, 6-11, 6-12, 6-13, 6-17, 6-24, 6-25, 6-26, 6-27	152761	Stud 6-2, 6-3
143321	Diode 6-23	151658	Screw (6-40x5/16 Fil) 6-3, 6-27	152763	Jumper 6-9
143322	Cord Assembly 6-23	151659	Screw (6-40x1/2 Fil) 6-15	152849	Armature 6-5
143323	Cord Assembly 6-23			152893	Screw (4-40x1/2 Hex) 6-19
143324	Cord Assembly 6-23			152921	Plate 6-3
143325	Transformer Assembly 6-23			152922	Plate 6-3
143326	Bracket 6-23			152950	Cable Assembly 6-6
143327	Cable Assembly 6-23				
144979	Relay 6-27				
145003	Relay 6-27				
145007	Diode 6-27				

## NUMERICAL INDEX - SECTION 6 (Continued)

Part Number	Description and Page Number	Part Number	Description and Page Number	Part Number	Description and Page Number
152988	Plate 6-26	155752	Sleeve, Insulating (1/16x3/8) 6-22, 6-24	159322	Plate, Relay 6-29
152994	Switch 6-3	155753	Sleeve, Insulating (1/8x1/2) 6-19, 6-25	159397	Modification Kit 6-18
152995	Bracket 6-26	155754	Sleeve, Insulating (1/16x1/2) 6-22	160223	Cable Assembly 6-16
152996	Suppressor, Electrical Noise 6-26	155755	Sleeve, Insulating (11/64x 5/8) 6-19	160226	Mounting Assembly 6-8, 6-18
152997	Cable Assembly 6-20	155785	Extension, Cable 6-18	160227	Cable Assembly 6-8
152998	Bracket 6-3	155858	Resistor (700 ohms) 6-3	160229	Plate 6-21
152999	Filter & Bell Assembly 6-26	155859	Screw (4-40x1/8 Binding) 6-2, 6-3, 6-20, 6-28	160284	Resistor (5500 ohms) 6-8, 6-18
153040	Control Assembly 6-5	155860	Screw (4-40x3/8 Rd) 6-2, 6-3, 6-20, 6-28	160325	Relay 6-19
153108	Insulator 6-6	155861	Washer, Lock 6-2, 6-3, 6-20, 6-28	160326	Relay 6-19
153157	Resistor (400 ohms) 6-5	156501	Screw (6-40x7/32 Fil) 6-24	160328	Relay 6-19
153251	Control Assembly 6-5	156976	Connector, Plug (32 Pt) 6-19	160332	Flasher, Thermal 6-19
153451	Block, Terminal 6-10	157216	Mounting Assembly 6-15	160334	Modification Kit 6-19
153454	Bracket 6-10	157217	Plate 6-15	160336	Cable Assembly 6-19
153456	Bracket 6-3	157218	Bracket 6-15	160357	Clip, Spring 6-19
153457	Strap, Terminal 6-3	157219	Spacer 6-15	160358	Cover 6-19
153458	Cable Assembly 6-4	157220	Block, Terminal 6-15	160359	Plate 6-19
153460	Plate 6-3	157221	Block, Terminal 6-15	160361	Clip, Mounting 6-19
153461	Plate 6-3	157222	Potentiometer 6-15	160362	Plug 6-19
153462	Plate 6-3, 6-17, 6-25, 6-27	157223	Jack 6-15, 6-24	160363	Capacitor (.6 MFD) 6-19
153464	Block, Terminal 6-8	157224	Resistor (250 ohms) 6-15	160364	Cable 6-19
153473	Cable Assembly 6-20	157225	Resistor (2000 ohms) 6-15	160365	Jumper 6-19
153475	Cable Assembly 6-8	157226	Block, Terminal 6-15	160389	Screw (12-24x1-1/4 Rd) 6-19
153477	Cable Assembly 6-6, 6-21	157227	Capacitor 6-15	160395	Cable 6-19
153478	Cable Assembly 6-5	157228	Cable 6-15	160411	Bracket 6-19
153479	Cable Assembly 6-12	157229	Cable Assembly 6-15	160678	Jumper 6-4
153480	Resistor (6750 ohms) 6-8	157230	Jumper 6-4	160831	Terminal 6-19
153481	Resistor (5800 ohms) 6-8, 6-10	157231	Jumper 6-4, 6-17	160847	Stud 6-13
153482	Plate, Relay 6-8	157232	Jumper 6-4, 6-17	160883	Plate 6-8
153483	Jumper 6-12	157233	Screw (6-40x2-3/8 Flat) 6-15	160964	Relay 6-19
153484	Screw (6-32x1/4 Fil) 6-22	157234	Potentiometer 6-15	160965	Modification Kit 6-19
153492	Connector, Plug (3 Pt) 6-27	157235	Resistor (390 ohms) 6-15	160966	Modification Kit 6-19
153493	Connector, Receptacle (3 Pt) 6-20	157236	Capacitor (.47 MFD) 6-25	161136	Fuse (6-1/4 AMP) 6-27
153537	Screw (6-40x9/32 Hex) 6-29	157283	Rectifier, Selenium 6-25	161238	Connector, Receptacle 6-24
153631	Network, Spark Suppression 6-24	157285	Resistor (5000 ohms) 6-25	161239	Connector, Plug 6-24
153819	Washer, Lock 6-24	157307	Spacer 6-13	161525	Connector, Plug (14 Pt) 6-22
154630	Plate 6-14	157308	Bracket 6-13	161526	Connector, Receptacle (14 Pt) 6-20, 6-22, 6-27
154632	Block, Terminal 6-13	157309	Plate, Nut 6-13	162357	Capacitor (500 MFD) 6-21, 6-24
154636	Plate 6-13	157310	Switch, Sensitive 6-13	162358	Diode 6-21, 6-24
154661	Rectifier 6-14	157312	Resistor (6000 ohms) 6-25	162359	Transformer 6-21, 6-24
154664	Resistor (2000 ohms) 6-17, 6-25	157313	Resistor (1800 ohms) 6-25	162360	Fuse (.8 amp) 6-21, 6-24
154665	Cable Assembly 6-13	157314	Socket, Tube (7 Pin) 6-25	162361	Rectifier 6-21
154696	Washer, Reducing 6-3	157315	Socket, Tube (9 Pin) 6-25	162461	Cable Assembly 6-20
154732	Modification Kit 6-25	157316	Cable Assembly 6-25	162835	Cable Assembly 6-20
154747	Modification Kit 6-17	157317	Shield, Tube 6-25	163316	Cable Assembly 6-20
154779	Modification Kit 6-25	157319	Tube, Electron (5751) 6-25	163696	Panel Assembly 6-22
154870	Cable Assembly 6-17, 6-25	157395	Plate 6-25	163697	Panel Assembly 6-22
155022	Switch, Toggle 6-2	157396	Board, w/Terminals 6-25	163795	Coil, Repeating 6-22
155023	Switch, Toggle 6-2, 6-27	157397	Bracket 6-25	163802	Connector, Receptacle (2 Pt) 6-22
155064	Jumper 6-4	157997	Cable 6-25	163803	Connector, Plug (2 Pt) 6-22
155084	Tube, Electron (2D21W) 6-25	157998	Jumper 6-4, 6-25	163804	Plate 6-22
155558	Relay Assembly 6-16	158250	Block, Terminal 6-27	163807	Cable Assembly 6-22
155559	Plate 6-16	158252	Insulator, Terminal Block 6-27	163808	Cable Assembly 6-22
155560	Relay 6-16	158272	Plate (Right) 6-2	163809	Cable Assembly 6-22
155561	Cable 6-16	158278	Container 6-2, 6-3	163810	Cable Assembly 6-22
155564	Cover 6-16	158279	Plate 6-20	163966	Plate 6-20
155591	Capacitor 6-6	158283	Connector, Receptacle (32 Pt) 6-19	164192	Cable Assembly 6-20
155592	Plate 6-16	159320	Cover, Relay 6-29	164238	Cable Assembly 6-20
155659	Cable Assembly 6-20	159321	Bracket, Relay 6-29	164239	Cable Assembly 6-20
155718	Jumper 6-17, 6-25			164271	Service Assembly, Electrical 6-24
155750	Sleeve, Insulating (3/32x 1/2) 6-19, 6-25			164503	Rectifier Assembly 6-23
155751	Sleeve, Insulating (1/8x1) 6-19			164606	Bracket 6-24

## NUMERICAL INDEX - SECTION 6 (Continued)

Part Number	Description and Page Number	Part Number	Description and Page Number	Part Number	Description and Page Number
165021	Relay 6-22	173144	Relay 6-24	176692	Relay 6-29
165060	Socket, Tube 6-27	173145	Cable Assembly 6-24	176693	Cable Assembly 6-29
165378	Resistor (102-3509 ohms) 6-22	173146	Panel, Relay Mounting 6-24	176694	Relay Assembly 6-29
171522	Resistor (400 ohms) 6-19	173147	Plate, Mounting 6-24	176696	Relay 6-29
171555	Connector, Receptacle (50 Pt) 6-27	173331	Bracket 6-24	176697	Cable Assembly 6-29
172942	Cable Assembly 6-24	173332	Insulator 6-24	176698	Relay Assembly 6-29
172943	Cable Assembly 6-24	173363	Modification Kit 6-24	176788	Capacitor (60 MFD) 6-29
172971	Board, Terminal 6-19	173724	Modification Kit 6-3	176810	Relay Assembly 6-29
		174306	Relay 6-19	176811	Plate, Mounting 6-29
		176673	Suppressor, Spark 6-3	176812	Cable Assembly 6-29

**SECTION 7**  
**NOTES OF EXPLANATION**  
**CONVERSION AND**  
**MODIFICATION KITS**



## NOTES OF EXPLANATION - SECTION 1

- Note 1: The 151127 shaft and one 151126 spacer have been replaced by a 154663 shaft and a 154662 spacer, replaceable only in pairs. When a new style shaft is ordered, a new style spacer will be furnished.
- Note 2: The 151126 spacer is not required on units equipped with the 152338 Modification Kit illustrated in Figure 1-23.
- Note 3: The 151176 base and 151179 terminals have been redesigned but retain their original part numbers. The new style terminals may be used with the old style base, but if it is necessary to replace the base, both the new style 151176 base and 151179 terminals should be ordered.

NOTES OF EXPLANATION - SECTION 2

- Note 1: The 111343 clamp is no longer required on units equipped with the redesigned 154086 wedge lock retainer. The new design retainer has an extension on the bottom edge which replaces the clamp. However, the 111343 clamp is available for units equipped with the early design 154086 retainer.
- Note 2: The 154053 clutch trip bail is replaced by the 164485 clutch trip bail when the unit is equipped with synchronous pulse transmission (see Figure 2-23).
- Note 3: The 164718 adapter plate and 164730 bracket replace the 172635 adapter plate and 172636 bracket for the Mark III Keyboard.
- Note 4: Parts marked (#) are peculiar to LBAC227\*\* and LBAC233\*\*.

## NOTES OF EXPLANATION - SECTION 3

- Note 1: Parts shown in Figure 3-3 are peculiar to LP3, LP4, LP5 and LP7.
- Note 2: Parts shown in Figure 3-4 are peculiar to LP68.
- Note 3: The Early Design 150098 Pressure Bail is no longer available and is replaced by a Late Design 157290 Pressure Bail. When the Late Design Pressure Bail is installed in an Early Design Mechanism, two 150269 Rollers and four 150266 Guide Levers are removed. All other parts are available for maintenance.
- Note 4: Parts shown in Figure 3-8 are common to LP3, LP4, LP5 and LP7.
- Note 5: The 150434 Transfer Bail is peculiar to LP3, LP4, LP5, LP6, LP7 and LP9.
- Note 6: The Early Design 153317 Bearing Bracket is no longer available and is replaced by a Late Design 157990 Bearing Bracket, 157991 Stud, 2669 Lock Washer and a 112626 Screw.
- Note 7: The 151346 Screw is used on LP3, LP4, LP5 and LP6.
- Note 8: The 151606 Screw is used on LP3 and LP5.
- Note 9: The 153326 Reset Blade is peculiar to LP3, LP4, LP5, LP7 and LP9.
- Note 10: Parts shown in Figure 3-10 are common to LP3, LP4, LP5 and LP7.
- Note 11: The 153560 Cam Shaft is no longer available. Orders received for this Early Design part will be filled with a 154789 Modification Kit to replace the 153560 Shaft and associated parts. (See Figure 3-9 for Components)
- Note 12: The 153573 Bail has been redesigned but retains its original number (See Figure 3-9 for Late Design).
- Note 13: Parts shown in Figure 3-15 are peculiar to LP3, LP4, LP5 and LP7.
- Note 14: Parts marked # are peculiar to LP3, LP4, LP5 and LP7.
- Note 15: Since the Type Box Alignment cannot be adjusted, the Early Design 152502 Type Box Carriage Plate is no longer furnished. When ordering the Early Design Plate, a 152502 Modification Kit to provide Type Box Alignment will be furnished (components listed on Page 7-9).
- Note 16: Parts marked \* are peculiar to LP72.
- Note 17: The 153883 Helical Gear is peculiar to LP8.
- Note 18: Parts marked # are peculiar to LP3 through LP9.
- Note 19: Parts marked \* are peculiar to LP3, LP4, LP5 and LP7.
- Note 20: Parts marked # are peculiar to LP3, LP4, LP5, LP6, LP7 and LP9.
- Note 21: Parts marked \* are peculiar to LP3, LP4, LP5 and LP7.
- Note 22: The 154625 Space Suppression Ring is peculiar to LP6, LP7, LP8 and LP9.
- Note 23: Parts shown in Figure 3-24 are common to LP3, LP4 and LP5.
- Note 24: Parts marked \* are peculiar to LP3 and LP4.
- Note 25: The Early Design 150953 Slide Assembly is no longer available and is replaced by a Late Design 153183 Slide Assembly and a 153946 Modification Kit to provide improved horizontal positioning knee link. (components listed on Page 7-13)
- Note 26: The 3598 Nut is peculiar to LP4, LP6, LP7 and LP9.

## NOTES OF EXPLANATION – SECTION 3 (Continued)

- Note 27: Parts marked \* are peculiar to LP8.
- Note 28: The 150438 Bellcrank is peculiar to LP3 and LP8.
- Note 29: The Early Design 152569 and 152570 Shift Slide Drive Linkages are no longer available. Orders received for these parts will be filled with a 153946 Modification Kit to provide an improved horizontal positioning knee link assembly. (components listed on Page 7-13)
- Note 30: The Early Design 152434 Plate is no longer available. Orders received for the 152434 Plate will be filled with a 153904 Modification Kit to provide parts for improved range scale sector mounting. (components listed on Page 7-11)
- Note 31: The Early Design 153491 Plate is no longer available. Orders received for the 153491 Plate will be filled with a 154723 Modification Kit to provide parts for improved range scale sector mounting. (components listed on Page 7-14)
- Note 32: The Early Design 152439 Shaft is no longer available. Orders received for the 152439 Shaft will be filled with a 157261 Shaft and a 119648 Retaining Ring.
- Note 33: The Early Design 152413 Magnet Bracket is no longer available. Orders received for the 152413 Magnet Bracket will be filled with a 153545 Magnet Bracket which may be identified by the "C" stamped on the pole piece.
- Note 34: The Early Design 152422 Armature (available for use with the Early Design 152413 Magnet Bracket) has been superseded by a 153543 Armature. For identification, the Late Design Armature will be marked with "Red Lacquer" on the underside, or have the armature extension finished in "Black Oxide" instead of nickel.
- Note 35: The 152554 Code Bar is peculiar to LP3.
- Note 36: Parts marked \*\* are peculiar to LP3, LP4, LP5 and LP7.
- Note 37: The Early and Late Design Type Boxes may be identified by the thickness of the Pallet Box Front Plate (Late Design being thinner); also the Dummy Pallets (150973) are not used in the "Thin" Type Box. The Early Design Pallets cannot be used in the "Thin" Type Boxes. Late Design Pallets can be used in either "Thick" or "Thin" Type Boxes. However, Late Design Pallets used in "Thin" Type Boxes must use the Late Design 157238 Pallet Springs.  
 The Early Design 150077 Pallet Spring is no longer available and is replaced by the Late Design 157238 Pallet Spring. However, either the Early or Late Design Spring can be used with a Late Design Pallet in a "Thick" Type Box.  
 Late Design Springs can be used on Early Design Pallets in "Thick" Type Boxes.  
 The Early and Late Design Pallets may be identified by the length of the shank from the rear of the pallet head to the end of the elongated hole. (The Early Design being the longer - see illustrations).
- Note 38: The Switch Assemblies shown in Figure 3-48 are no longer available and have been replaced by Later Design Switch Assemblies. (shown in Figure 3-47) The replacements are as follows: The 155917 through 155924 Switch Assemblies have been replaced by 172600 through 172607 Switch Assemblies respectively. The 157070 through 157100 Switch Assemblies have been replaced by 172500 through 172530 Switch Assemblies respectively. The 160192 through 160197 Switch Assemblies have been replaced by 172531 through 172536 Switch Assemblies respectively. The 160198 Switch Assembly has been replaced by a 172534 Switch Assembly. The 160199 through 160218 Switch Assemblies have been replaced by 172538 through 172557 Switch Assemblies respectively. The 160219 Switch Assembly has been replaced by a 172560 Switch Assembly. The 160220 Switch Assembly has been replaced by a 172559 Switch Assembly.

## NOTES OF EXPLANATION - SECTION 5

- Note 1: The redesigned cabinet necessitated a change in the window. The early model windows were 3-3/8" in width, numbered 153043 glass and 151510 plastic. The later design cabinet has windows 3-5/8" in width, numbered 152768 glass and 153042 plastic.
- Note 2: Parts marked with an asterisk (\*) are discontinued. When it is necessary to replace a discontinued part a 161306 Modification Kit should be ordered instead. See figure 5-2 for component parts.
- Note 3: Parts marked (†) are peculiar to the LPC207\*\*.
- Note 4: The 121244 cable clamp is peculiar to the LPC206\*\*.
- Note 5: Parts marked (#) are used to secure the base in rack mounting.
- Note 6: The 145077\*\* Lower Cabinet is similar to the 153488\*\* Lower Cabinet but provides additional rectangular cut-outs in the upper and lower shelves to accommodate special cabling.
- The 153488\*\* Lower Cabinet is the standard KSR Cabinet and replaces the 153100\*\* Lower Cabinet which is of an earlier design.
- The 178900\*\* Lower Cabinet is similar to the 153488\*\* Lower Cabinet but provides new mounting holes for the new style copyholder illustrated in Figure 5-62.

## CONVERSION AND MODIFICATION KITS FOR THE PAGE PRINTER SET

Kit Number	Part Number	Description	Quantity	Figure Number	Specification Number
152307		Modification Kit to Provide Reperforator Control Mechanism on Stunt Box			5760S and 5813S
	3599	Nut (4-40 Hex)	1	3-46	
	4703	Spring	2	3-50	
	72522	Wick, Felt	2	3-46	
	90517	Spring	3	3-46	
	94693	Wick, Felt	2	3-46	
	110743	Washer, Lock	1	3-46	
	152089	Latch	1	3-46	
	152298	Lever	1	3-46	
	152299	Lever	1	3-46	
	152357	Stud	1	3-46	
	152653	Pawl	2	3-46	
	152660	Plate, Spring	1	3-46	
	153440	Bar, Function (Uncoded)	2	3-50	
	157074	Switch Assembly	1	3-48	
	157200	Spring	2	3-46	
	157240	Spring	2	3-46	
	157975	Cable	1	3-49	
152316		Modification Kit to convert friction feed typing unit to sprocket feed (includes all parts shown in figure 3-12 plus the following parts)			5792S
	153810	Guide, Ribbon	1	3-16	
	157979	Link, Toggle	1	3-37	
		In addition to the above Kit, order one of the following Modification Kits for your specific paper width:			
		153701 through			
		153717 Modification Kits to Provide Paper Handling Parts	1	3-69	
152321		Universal Copy Light Conversion			5775S
	3438	Washer, Flat	2	5-3	
	3639	Washer, Lock	2	5-3	
	121245	Clamp, Cable	1	5-3	
	152309	Copylight Assembly	1	5-3	
	152319	Modification Kit to Provide Additional Terminal Connections on Cabinet	1	5-13	
	153400	Lamp, Incandescent (6 Watt - 60 Volt)	1	5-13	
	153442	Screw (10-32 x 1/2 Hex)	2	5-3	
152322		Modification Kit to provide Automatic Carriage Return and Line Feed Mechanism on Typing Units LP3 thru 9			5788S
	2191	Washer, Lock	1	3-24	
	8330	Washer, Flat	1	3-24	
	95827	Bushing	1	3-27	
	110436	Spring	1	3-27	
	150438	Bellcrank	1	3-27	
	151346	Screw (6-40 x 3/8 Fil)	1	3-24	
	152554	Bar, Code (Automatic CR & LF)	1	3-39	
	152591	Arm, Automatic CR & LF	1	3-24	
	152634	Washer, Flat	1	3-27	

## CONVERSION AND MODIFICATION KITS FOR THE PAGE PRINTER (Continued)

Kit Number	Part Number	Description	Quantity	Figure Number	Specification Number
152324		Electrical Service Unit Conversion From LESU5 to LESU7			5790S
	2191	Washer, Lock	3	6-2	
	3598	Nut (6-40 Hex)	1	6-2	
	75750	Washer, Fiber	2	6-2	
	80854	Screw (6-40 x 1-7/16 Fil)	1	6-2	
	111017	Screw (6-40 x 5/16 Fil)	9	6-2	
	121247	Clamp, Cable	2	6-2	
	129919	Fuse (4 Amp)	1	6-2	
	150040	Screw (6-40 x 5/8 Fil)	2	6-2	
	151411	Block, Terminal	1	6-2	
	151412	Insulator	1	6-2	
	151416	Nut (6-40 Hex)	9	6-2	
	151818	Jumper Assembly (4-1/4" Black)	1	6-3	
	151819	Jumper Assembly (2-1/2" Black)	15	6-3	
	151827	Strap, Terminal	2	6-2	
	153456	Bracket	1	6-2	
	153457	Strap, Terminal	1	6-2	
	153460	Plate, Left Mounting	1	6-2	
	153461	Plate, Right Mounting	1	6-2	
	153462	Plate	1	6-2	
	153473	Cable Assembly	1	6-24	
	155858	Resistor (700 Ohm)	1	6-2	
152325		Line Test Key Conversion From 152744 to 152625			5701S
	1038	Screw (6-40 x 9/32 Fil)	1	6-10	
	2191	Washer, Lock	1	6-10	
	3598	Nut (6-40 Hex)	1	6-10	
	77902	Screw (6-40 x 2-1/2 Rd)	1	6-10	
	110743	Washer, Lock	2	6-10	
	125011	Washer, Flat	2	6-10	
	151637	Screw (4-40 x 1/4 Fil)	2	6-10	
	151819	Jumper Assembly (2-1/2" Black)	1	6-10	
	153451	Block Assembly, Terminal	1	6-10	
	153454	Bracket	1	6-10	
	153476	Cable Assembly	1	6-10	
	153481	Resistor (5800 Ohm)	1	6-10	
152326		Line Relay Mounting Conversion From 151822 to 152623			5664S
	1038	Screw (6-40 x 9/32 Fil)	2	6-8	
	2191	Washer, Lock	6	6-8	
	7002	Washer, Flat	2	6-8	
	77902	Screw (6-40 x 2-1/2 Rd)	4	6-8	
	125015	Washer, Flat	4	6-8	
	151819	Jumper Assembly (2-1/2" Black)	1	6-8	
	152110	Bracket	2	6-8	
	153464	Block Assembly, Terminal	1	6-8	
	153475	Cable Assembly	1	6-8	
	153480	Resistor (6750 Ohm)	1	6-8	
	153481	Resistor (5800 Ohm)	1	6-8	
	153482	Plate, Relay	1	6-8	
152328		Capacitor-Resistor Conversion From 152021 to 152624			5662S
	151657	Screw (6-40 x 1/4 Fil)	1	6-12	
	153479	Cable Assembly	1	6-12	
	153483	Jumper Assembly (9" Black)	2	6-12	

## CONVERSION AND MODIFICATION KITS FOR THE PAGE PRINTER (Continued)

Kit Number	Part Number	Description	Quantity	Figure Number	Specification Number
152329		Motor Control Conversion From 151400 to 153251			5706S
	121245	Clamp, Cable	1	6-5	
	151632	Screw (6-40 x 3/8 Hex)	1	6-5	
	153478	Cable Assembly	1	6-5	
152335		Modification Kit to Provide Automatic Carriage Return and Line Feed Mechanism on Stunt Box			5788S
	4703	Spring	2	3-50	
	72522	Wick, Felt	2	3-46	
	90517	Spring	2	3-46	
	94693	Wick, Felt	2	3-46	
	152641	Lever	2	3-46	
	152653	Pawl	2	3-46	
	152660	Plate, Spring	2	3-46	
	152671	Bar, Function (CR-LF)	2	3-50	
	157200	Spring	2	3-46	
	157240	Spring	2	3-46	
152502		Modification Kit to Provide Type Box Alignment Adjustment Parts			5830S
	74553	Wick, Felt	1	3-16	
	74882	Spring	1	3-16	
	151880	Nut (4-40)	1	3-16	
	153530	Plate	1	3-16	
	153531	Plate, Adjusting	1	3-16	
	153532	Screw, Adjusting (4-40)	1	3-16	
152718		Modification Kit to Provide Mechanism on Stunt Box for Motor Stop Function on Upper Case "H"			5671S
	4703	Spring	1	3-50	
	72522	Wick, Felt	1	3-46	
	90517	Spring	1	3-46	
	94693	Wick, Felt	1	3-46	
	110743	Washer, Lock	1	3-46	
	119651	Ring, Retaining	1	3-44	
	121245	Clamp, Cable	1	3-44	
	150973	Pallet, Dummy	1	3-42	
	151903	Keylever	1	1-15	
	151686	Screw (4-40 x 3/8 Fil)	1	3-45	
	152641	Lever	1	3-46	
	152653	Pawl	1	3-46	
	152660	Plate, Spring	1	3-46	
	152673	Bar, Function (UC H)	1	3-50	
	152720	Contact Assembly	1	3-45	
	157200	Spring	1	3-46	
	157238	Spring	1	3-41	
157240	Spring	1	3-46		
152719		Modification Kit to Provide Mechanism on Stunt Box for Motor Stop Function on Upper Case "M"			5671S
	4703	Spring	1	3-50	
	72522	Wick, Felt	1	3-46	
	90517	Spring	1	3-46	
	94693	Wick, Felt	1	3-46	
	110743	Washer, Lock	1	3-46	
	119651	Ring, Retaining	1	3-44	
	121245	Clamp, Cable	1	3-44	



## CONVERSION AND MODIFICATION KITS FOR THE PAGE PRINTER (Continued)

Kit Number	Part Number	Description	Quantity	Figure Number	Specification Number
	150973	Pallet, Dummy	1	3-42	
	151686	Screw (4-40 x 3/8 Fil)	1	3-45	
	152019	Stop, Keylever	1		
	152641	Lever	1	3-46	
	152653	Pawl	1	3-46	
	152660	Plate, Spring	1	3-46	
	152674	Bar, Function (M)	1	3-50	
	152720	Contact Assembly	1	3-45	
	157200	Spring	1	3-46	
	157238	Spring	1	3-41	
	157240	Spring	1	3-46	
152900		Modification Kit to Provide Mechanism on Stunt Box for Spacing on Upper Case "Blank"			57845
	4703	Spring	1	3-50	
	72522	Wick, Felt	1	3-46	
	90517	Spring	1	3-46	
	94693	Wick, Felt	1	3-46	
	152127	Clip	1	3-43	
	152641	Lever	1	3-46	
	152653	Pawl	1	3-46	
	152660	Plate, Spring	1	3-46	
	152675	Bar, Function (LC "Blank")	1	3-50	
	157200	Spring	1	3-46	
	157240	Spring	1	3-46	
	157274	Clip	1	3-44	
152914		Modification Kit to Add XD Control			57465
	110434	Screw (4-40 x 3/16 Fil)	2	1-19	
	110743	Washer, Lock	2	1-19	
	151446	Switch Assembly (Includes the following parts)	1		
	3599	Nut (4-40)	1	1-19	
	55669	Spring (or 49420)	1	1-19	
	102057	Screw, Shoulder (4-40)	1	1-19	
	125181	Screw (2-56 x 3/8 Fil)	2	1-19	
	151329	Switch, Sensitive	1	1-19	
	151341	Lever, Contact	1	1-19	
	151342	Bracket	1	1-19	
152919		Modification Kit to Convert a typing unit from communications service to weather map service.			57195
	119651	Ring, Retaining	1		
	151683	Box Assembly, Type (Arrangement "RE")	1		
	151739AE	Screw, Identification	1	1-15	
	151739RE	Screw, Identification	1	2-53	
	152001	Keylever Assembly	1	1-15	
	152002	Keylever Assembly	1	1-15	
	152003	Keylever Assembly	1	1-15	
	152004	Keylever Assembly	1	1-15	
	152005	Keylever Assembly	1	1-15	
	152006	Keylever Assembly	1	1-15	
	152008	Keylever Assembly	1	1-15	
	152010	Keylever Assembly	1	1-15	
	152011	Keylever Assembly	1	1-15	
	152012	Keylever Assembly	1	1-15	
	152013	Keylever Assembly	1	1-15	
	152014	Keylever Assembly	1	1-15	

## CONVERSION AND MODIFICATION KITS FOR THE PAGE PRINTER (Continued)

Kit Number	Part Number	Description	Quantity	Figure Number	Specification Number
	152015	Keylever Assembly	1	1-15	
	152016	Keylever Assembly	1	1-15	
	152675	Bar, Function (LC BL)	1	2-53	
	152889	Plate, Retaining	1	2-53	
153904		Modification Kit to Provide Parts for Improved Range Scale Selector Mounting			5843S
	2669	Washer, Lock	1	3-32	
	112626	Nut (10-32 Hex)	1	3-32	
	119652	Ring, Retaining	2	3-32	
	152441	Washer, Flat	2	3-32	
	153489	Detent	1	3-32	
	155096	Plate W/Studs	1	3-32	
153905		Modification Kit to Provide Universal Spacing Drum on Typing Unit			5816S
	2191	Washer, Lock	7	3-23	
	7002	Washer, Flat	4	3-23	
	151346	Screw (6-40 x 3/8 Fil)	3	3-23	
	151631	Screw (6-40 x 5/16 Hex)	1	3-23	
	151658	Screw (6-40 x 5/16 Fil)	2	3-23	
	154623	Ring, Retaining	1	3-23	
	154624	Ring, Carriage Return	1	3-23	
	154625	Ring, Space Suppression	1	3-23	
	154627	Drum, Spacing	1	3-23	
	156632	Screw (6-40 x 13/32 Hex)	1	3-23	
153906		Modification Kit to Provide Trip Shaft Support Bracket on Typing Unit			5811S
	2191	Washer, Lock	4	3-7	
	3598	Nut (6-40 Hex)	1	3-7	
	7002	Washer, Flat	1	3-7	
	93758	Washer, Felt	1	3-7	
	151346	Screw (6-40 x 3/8 Fil)	1	3-7	
	151630	Screw (6-40 x 1/4 Hex)	2	3-7	
	155041	Plate	1	3-7	
	155042	Bracket	1	3-7	
	162729	Bar	1	3-7	
153907		Modification Kit to Provide Page Feed-Out and Transmitter Control Features on Typing Unit			5751S
	152302	Modification Kit, Page Feed-Out	1	3-53	
	152303	Modification Kit, Transmitter Control	1	3-54	
153914		Modification Kit to Provide Universal Spacing Drum with Automatic CR and LF on Typing Unit			5816S
	2191	Washer, Lock	7	3-23	
	7002	Washer, Flat	4	3-23	
	151346	Screw (6-40 x 3/8 Fil)	3	3-23	
	151631	Screw (6-40 x 5/16 Hex)	1	3-23	
	151658	Screw (6-40 x 5/16 Fil)	2	3-23	
	154623	Ring, Retaining	1	3-23	
	154624	Ring, Carriage Return	1	3-23	
	154626	Ring, Automatic CR and LF	1	3-23	
	154627	Drum, Spacing	1	3-23	
	156632	Screw (6-40 x 13/32 Hex)	1	3-23	

## CONVERSION AND MODIFICATION KITS FOR THE PAGE PRINTER (Continued)

Kit Number	Part Number	Description	Quantity	Figure Number	Specification Number
153924		Modification Kit to Provide Stunt Box with Upper Case "Blank-H" Motor Control Mechanism			58335
	4703	Spring	2	3-50	
	72522	Wick, Felt	2	3-46	
	90517	Spring	2	3-46	
	152121	Lever	1	3-46	
	152653	Pawl	2	3-46	
	152660	Plate, Spring	1	3-46	
	154613	Latch	1	3-46	
	154647	Lever	1	3-46	
	155247	Bar, Function (Blank)	1	3-50	
	155288	Bar, Function (H)	1	3-50	
	157074	Switch Assembly	1	3-48	
	157105	Cable Assembly	1	3-49	
	157240	Spring	2	3-46	
153941		Typing Unit Conversion to Selective Calling (Bell System 28D to 28E, 28B to 28F, 28C to 28G)			58475
	3599	Nut (6-40)	4	3-46	
	4703	Spring	9	3-50	
	72522	Spring	9	3-46	
	90517	Spring	9	3-46	
	110743	Washer, Lock	4	3-46	
	119649	Ring, Retaining	2	3-44	
	121243	Clamp, Cable	1	3-44	
	125011	Washer, Flat	4	3-44	
	151739	Screw, Identification (6-40)	1	3-44	
	152089	Latch	3	3-46	
	152121	Lever	2	3-46	
	152298	Lever, Function	3	3-46	
	152337	Modification Kit to Add On-Line Stunt Shift Control	1	3-64	58235
	152642	Lever	2	3-46	
	152653	Pawl	9	3-46	
	152660	Plate, Spring	3	3-46	
	152665	Bar, Function (LTR)	1	3-50	
	152666	Bar, Function (FIG)	2	3-50	
	152667	Bar, Function (CR)	1	3-50	
	152668	Bar, Function (LF)	1	3-50	
	152673	Bar, Function (UC H)	1	3-50	
	153608	Fork	2	3-45	
	153609	Roller	2	3-45	
	153644	Stud	4	3-45	
	153645	Plate, Guide	4	3-45	
	153646	Bushing	8	3-45	
	153647	Plate	2	3-45	
	153795	Slide	1	3-45	
	153919	Modification Kit to Add Auxillary Connector	1	3-68	58205
	153920	Modification Kit to Adapt Cabinet For Selective Calling	1	5-10	58275
	153945	Modification Kit to Add "O" Code Bar and Bellicrank	1	3-67	57885
	154613	Latch	3	3-46	
	154639	Slide	1	3-45	
	154646	Lever, Function	1	3-46	
	154647	Lever, Function	2	3-47	
	154669	Shaft	1	3-44	
	155120	Bar, Function (U)	1	3-50	
	155126	Bar, Function (-)	1	3-50	

## CONVERSION AND MODIFICATION KITS FOR THE PAGE PRINTER (Continued)

Kit Number	Part Number	Description	Quantity	Figure Number	Specification Number
	155129	Bar, Function (SP)	1	3-50	
	155130	Bar, Function (LF)	1	3-50	
	157073	Switch Assembly	1	3-48	
	157104	Cable Assembly	1	3-49	
	157240	Spring	9	3-46	
153946		Modification Kit to Provide Improved Horizontal Positioning Knee Link Assembly on Typing Unit			58075
	153331	Linkage, Drive (Left)	1	3-28	
	153332	Linkage, Drive (Right)	1	3-28	
	153335	Plate	1	3-28	
	153337	Bushing	2	3-28	
	153340	Spring (Left)	1	3-28	
	153341	Spring (Right)	1	3-28	
153947		Modification Kit to Provide Improved Oscillator Shift Knee Link Assembly on Typing Unit			58105
	153172	Spring, Knee Link	2	3-25	
	153173	Plate, Clamp	2	3-25	
	153174	Link (Left)	1	3-25	
	153175	Link (Right)	1	3-25	
	153180	Link (Right)	1	3-25	
	153181	Link (Left)	1	3-25	
153948		Modification Kit to Provide Time Delay Motor Stop Disabler Mechanism on Stunt Box			58335
	3599	Nut (4-40 Hex)	1	3-46	
	4703	Spring	1	3-50	
	72522	Wick, Felt	1	3-46	
	90517	Spring	1	3-46	
	110743	Washer, Lock	1	3-46	
	152089	Latch	1	3-46	
	152298	Lever	1	3-46	
	152357	Stud	1	3-46	
	152653	Pawl	1	3-46	
	152667	Bar, Function (C-R)	1	3-50	
	157240	Spring	1	3-46	
	157889	Spring	1	3-48	
	157899	Arm, Contact	1	3-48	
153949		Modification Kit to Provide Improved Magnet Bracket Assembly on Typing Unit			58155
	153184	Post	1	3-34	
	153543	Armature Assembly	1	3-34	
	153545	Bracket Assembly, Magnet	1	3-34	
153950		Modification Kit to Provide "O" Code Bar Bracket on Typing Unit			
	110743	Washer, Lock	1	3-65	
	151152	Screw (4-40 x 3/16 Hex)	1	3-65	
	153315	Bracket	1	3-65	
154350		Modification Kit to Provide Mark III Keyboard with Improved Code Bar Reset Bail			59945
	8449	Collar	1	2-12	
	90679	Washer, Felt	1	2-12	
	111767	Washer, Flat	1	2-12	

## CONVERSION AND MODIFICATION KITS FOR THE PAGE PRINTER (Continued)

Kit Number	Part Number	Description	Quantity	Figure Number	Specification Number
	154240	Bail, Code Bar Reset	1	2-12	
	154241	Stud	1	2-12	
154723		Modification Kit to Provide Parts for Improved Range Scale Sector Mounting			5843S
	119652	Ring, Retaining	2	3-32	
	152441	Washer, Flat	2	3-32	
	155096	Plate W/Studs	1	3-32	
154726		Modification Kit to Convert From Mechanical to Electrical Signal Line Break Mechanism			5796S
	2191	Washer, Lock	1	1-16	
	125181	Screw (2-56 x 3/8 Fil)	2	1-16	
	153626	Insulator	1	1-16	
	153627	Screw, Pilot (6-40)	1	1-16	
	153629	Lever, Break	1	1-16	
	153630	Bracket	1	1-16	
	153632	Switch and Cable Assembly	1	1-16	
154750		Modification Kit to Provide Shift Mechanism on Stunt Box			5824S
	3599	Nut (4-40 Hex)	2	3-46	
	110743	Washer, Lock	2	3-46	
	125011	Washer, Flat	2	3-44	
	153608	Fork	1	3-45	
	153609	Roller	1	3-45	
	153644	Stud	2	3-45	
	153645	Plate	2	3-45	
	153646	Bushing	4	3-45	
	153647	Plate	1	3-45	
	157164	Slide	1	3-45	
154782		Modification Kit to Provide Mechanism on Stunt Box to Prevent Locking-out of the Typing Unit			5857S
	90517	Spring	1	3-46	
	152641	Lever	1	3-46	
	152660	Plate	1	3-46	
	155066	Cable	1	3-49	
	155713	Clip	1	3-46	
	157071	Switch Assembly	1	3-48	
154787		Modification Kit to Provide Mechanism on Stunt Box to Hold Function Lever Shaft Securely in Place			5859S
	157275	Clip	3	3-44	
154789		Modification Kit to Provide Replacement Parts for the 153560 Shaft and Associated Parts			5773S
	2191	Washer, Lock	1	3-9	
	3598	Nut (6-40)	1	3-9	
	155864	Shaft	1	3-9	
	155865	Stud	1	3-9	
159355		Modification Kit to Provide a Shift Slide Mechanism on Stunt Box			5824S
	3599	Nut (4-40 Hex)	2	3-46	
	110743	Washer, Lock	2	3-46	
	125011	Washer, Flat	2	3-45	

## CONVERSION AND MODIFICATION KITS FOR THE PAGE PRINTER (Continued)

Kit Number	Part Number	Description	Quantity	Figure Number	Specification Number
	153608	Fork	1	3-45	
	153609	Roller	1	3-45	
	153644	Stud	2	3-45	
	153645	Plate	2	3-45	
	153646	Bushing	4	3-45	
	153647	Plate	1	3-45	
	153795	Slide	1	3-45	
159356		Modification Kit to Provide Replacement Parts for the 153771 thru 153787 Guide Bracket on Sprocket Feed Typing Units			5792S
	110434	Screw (4-40 x 3/16 Fil)	4	3-12	
	110743	Washer, Lock	2	3-12	
	125011	Washer, Flat	4	3-12	
	155565	Arm (Right)	1	3-12	
	155566	Arm (Left)	1	3-12	
	155896	Finger, Paper Left	1	3-12	
	155897	Finger, Paper Right	1	3-12	
159369		Modification Kit to Provide a Normally Open Contact Mechanism on Stunt Box			5782S
	157887	Arm, Contact	1	3-48	
	157889	Spring	1	3-48	
	157891	Plate	1	3-48	
159370		Modification Kit to Provide a Normally Closed Contact Mechanism on Stunt Box			5782S
	157889	Spring	1	3-48	
	157891	Plate	1	3-48	
	157899	Arm, Contact	1	3-48	
161441		Modification Kit to Convert Typing Unit from Sprocket Feed to Friction Feed			5910S
	2191	Washer, Lock	13	3-7, 3-9, 3-12	
	3598	Nut (6-40 Hex)	6	3-7	
	72468	Spring	1	3-5	
	74701	Spring	2	3-5	
	110743	Washer, Lock	4	3-5, 3-12	
	119651	Ring, Retaining	2	3-5	
	124681	Screw, Set	4	3-5	
	125011	Washer, Flat	3	3-5, 3-9	
	125015	Washer, Flat	5	3-5	
	125802	Washer, Flat	1	3-12	
	150096	Roller Assembly, Pressure	1	3-5	
	150269	Roller, Pressure	2	3-5	
	150270	Link, Pressure Roller Release	1	3-5	
	150276	Lever, Paper Release	1	3-5	
	150436	Bushing	1	3-5	
	150666	Gear, Idler	1	3-12	
	150685	Shaft W/Plate	1	3-5	
	150714	Bearing, Sleeve	2	3-12	
	150803	Spring, Flat	2	3-5	
	150804	Finger, Paper	1	3-5	
	150815	Bushing	2	3-5	
	150816	Lever	2	3-5	
	150826	Finger, Paper	1	3-5	
	150833	Platen Assembly	1	3-12	

## CONVERSION AND MODIFICATION KITS FOR THE PAGE PRINTER (Continued)

Kit Number	Part Number	Description	Quantity	Figure Number	Specification Number
	150840	Bracket, Guide	1	3-5	
	150900	Bail, Detent	1	3-1	
	150903	Block (Left)	1	3-9	
	150904	Block (Right)	1	3-9	
	150907	Spindle, Paper	1	3-9	
	150969	Spring, Torsion	1	3-1	
	150992	Stud	2	3-5	
	151346	Screw (6-40 x 3/8 Fil)	1	3-9	
	151545	Guide, Form	1	5-1,5-15,5-29,5-35	
	151637	Screw (4-40 x 1/4 Fil)	1	3-12	
	151657	Screw (6-40 x 1/4 Fil)	3	3-5	
	151686	Screw (4-40 x 3/8 Fil)	2	3-5	
	151692	Screw (6-40 x 3/16 Fil)	4	3-5	
	151703	Pin	1	3-5	
	151721	Screw (6-40 x 3/4 Hex)	2	3-9	
	152539	Guide, Paper	1	3-5	
	152831	Clip	2	3-1	
	152832	Shaft	1	3-5	
	152871	Spring	1	3-12	
	153634	Collar, Set	2	3-5	
	153839	Screw (6-40 x 5/8 Hex)	1	3-9	
	153841	Screw (6-40 x 9/16 Hex)	2	3-9	
162012		Modification Kit to Provide Shift Mechanism on Stunt Box			58245
	3599	Nut (4-40 Hex)	2	3-46	
	103863	Bushing	4	3-45	
	110743	Washer, Lock	2	3-46	
	125011	Washer, Flat	2	3-45	
	153609	Roller	1	3-45	
	153644	Stud	2	3-45	
	155933	Plate	2	3-45	
	155934	Plate	1	3-45	
	155935	Fork	1	3-45	
	155939	Slide	1	3-45	
162013		Modification Kit to Provide Shift Slide Mechanism on Stunt Box			58245
	3599	Nut (4-40 Hex)	2	3-46	
	103863	Bushing	4	3-45	
	110743	Washer, Lock	2	3-45	
	125011	Washer, Flat	2	3-45	
	153609	Roller	1	3-45	
	153644	Stud	2	3-45	
	155933	Plate	2	3-45	
	155934	Plate	1	3-45	
	155935	Fork	1	3-45	
	155938	Slide	1	3-45	
162866		Modification Kit to Provide Normally Open and Normally Closed Contact Arms Mechanism on Stunt Box			57825
	157887	Arm Contact	1	3-48	
	157889	Spring	2	3-48	
	157892	Plate	1	3-48	
	157899	Arm, Contact	1	3-48	

## CONVERSION AND MODIFICATION KITS FOR THE PAGE PRINTER (Continued)

Kit Number	Part Number	Description	Quantity	Figure Number	Specification Number
163518		Modification Kit to Adapt the Vertical Tabulator Control Mechanism for Use with an LXD			57515
	110743	Washer, Lock	2	3-48	
	151689	Screw (4-40 x 3/4 Fil)	2	3-48	
	151797	Cable Assembly	1	3-49	
	157884	Block	1	3-48	
	157889	Spring	2	3-48	
	157890	Plate, Contact	1	3-48	
	157899	Arm, Contact	2	3-48	
164079		Modification Kit to Provide a Two-Letter Code Directing Call Mechanism on Stunt Box			
	4703	Spring	2	3-50	
	72522	Wick, Felt	2	3-46	
	90517	Spring	2	3-46	
	152653	Pawl	2	3-46	
	153440	Bar, Function (Universal)	2	3-50	
	154613	Latch	2	3-46	
	157078	Switch Assembly	1	3-48	
	157206	Lever	1	3-46	
	157207	Lever	1	3-46	
	157240	Spring	2	3-46	
174491		Modification Kit to Provide R.F. Suppression for Signal Generator Contacts of Mark III Keyboard			
	154190	Filter, R.F.	1	2-14	
	154226	Box Assembly, Strap and contact	1	2-14	



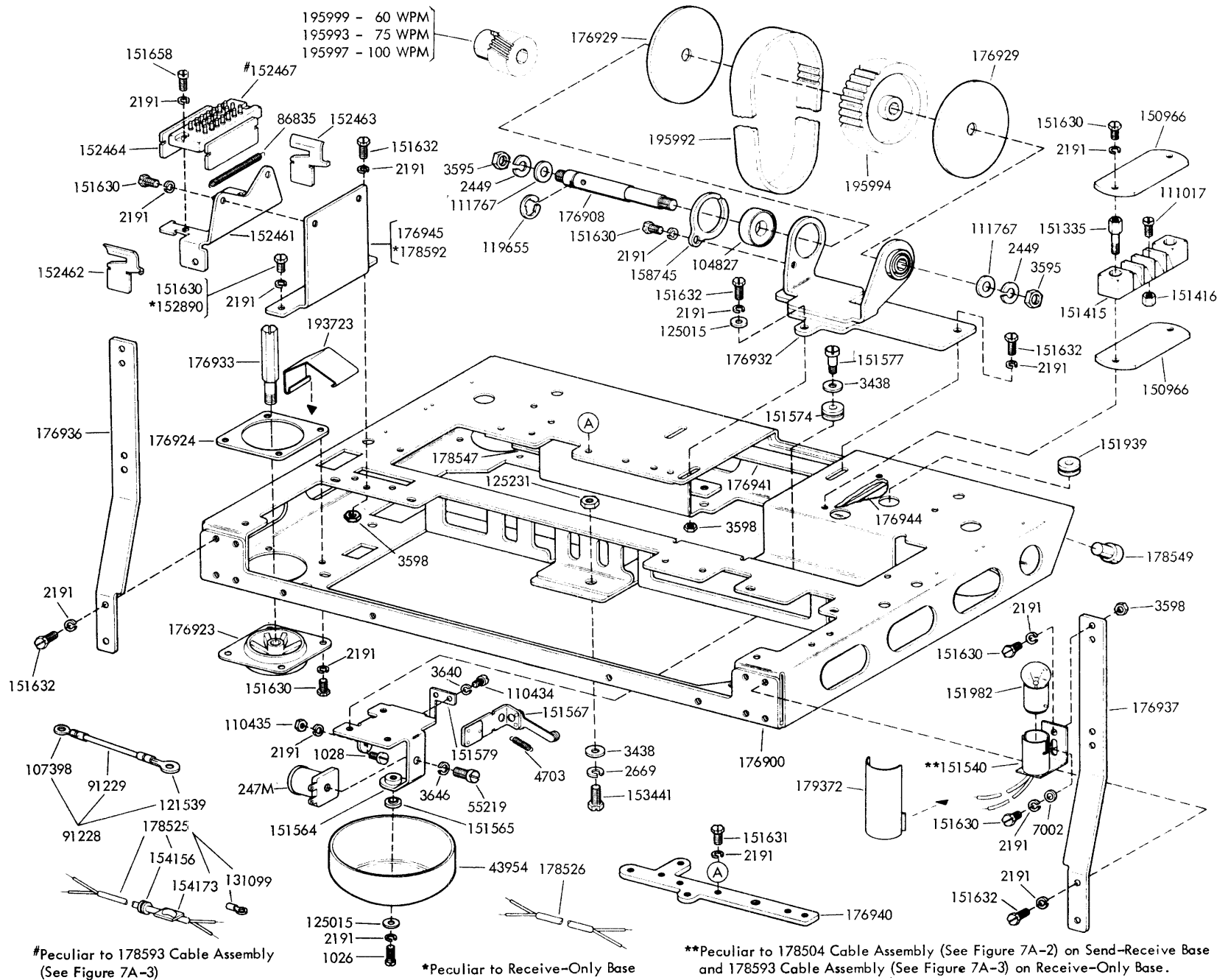
# SECTION 7A

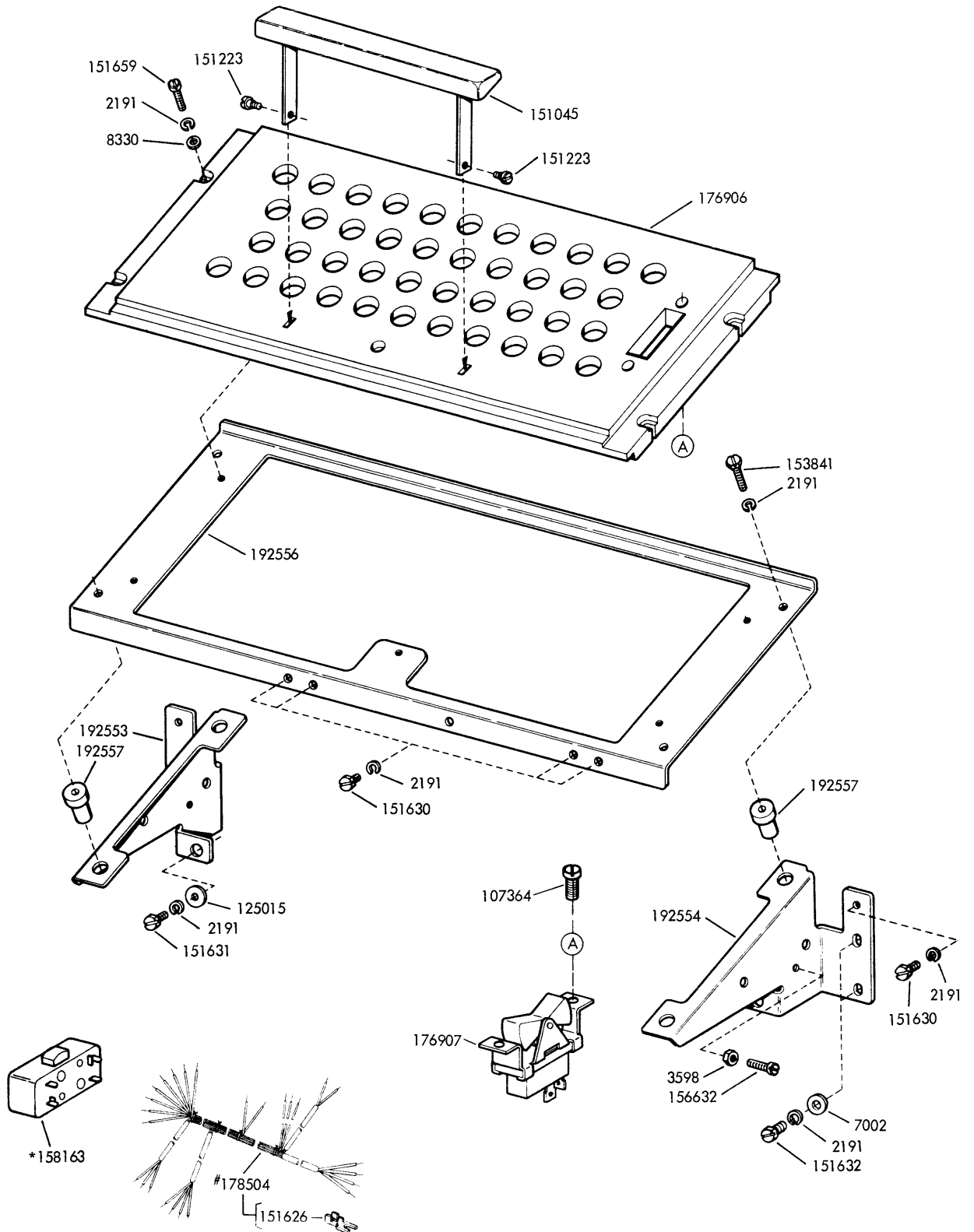
## WALL MOUNTED UNITS

**Note:**

The parts shown in this section are peculiar to wall mounted units. For standard parts not shown, see the appropriate bulletin section. Part numbers pertaining to Section 7A have not been included in the Master Numerical Index, Section 8.

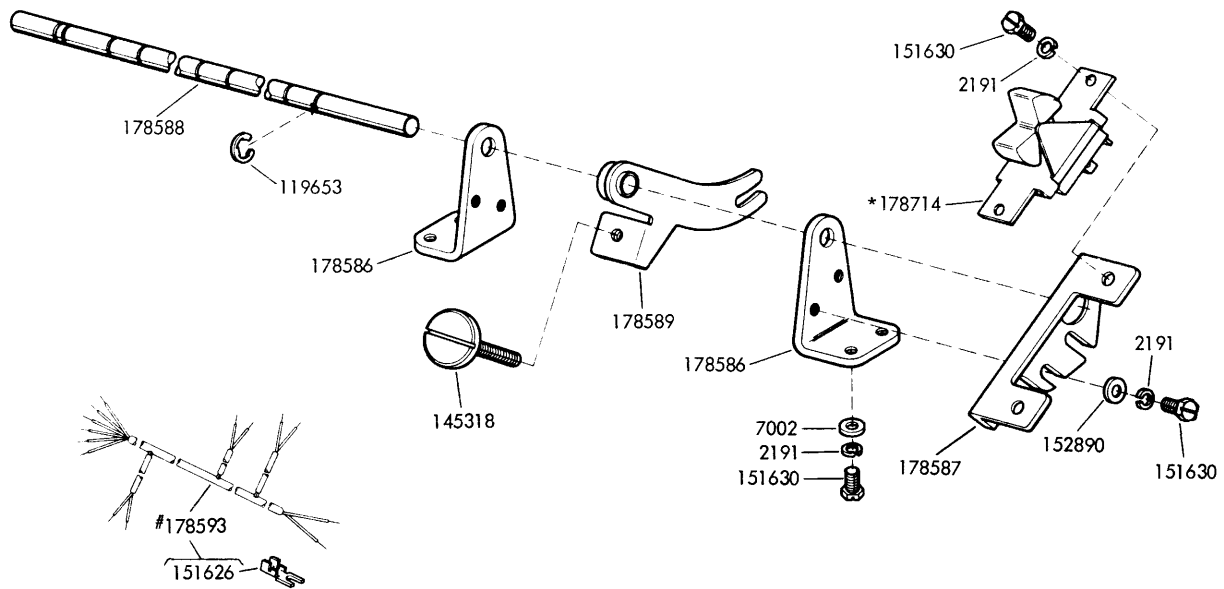
FIGURE 7A-1. KEYBOARD AND BASE MECHANISM





\*Part of 178504 Cable Assembly  
#Also includes 151540 Lampholder  
shown in Figure 7A-1.

FIGURE 7A-2. KEYBOARD MECHANISM



#Also includes the 151540 Lampholder and the 152467 Connector shown in Figure 7A-1.

\*Part of 178593 Cable Assembly

FIGURE 7A-3. TRIP LEVER MECHANISM

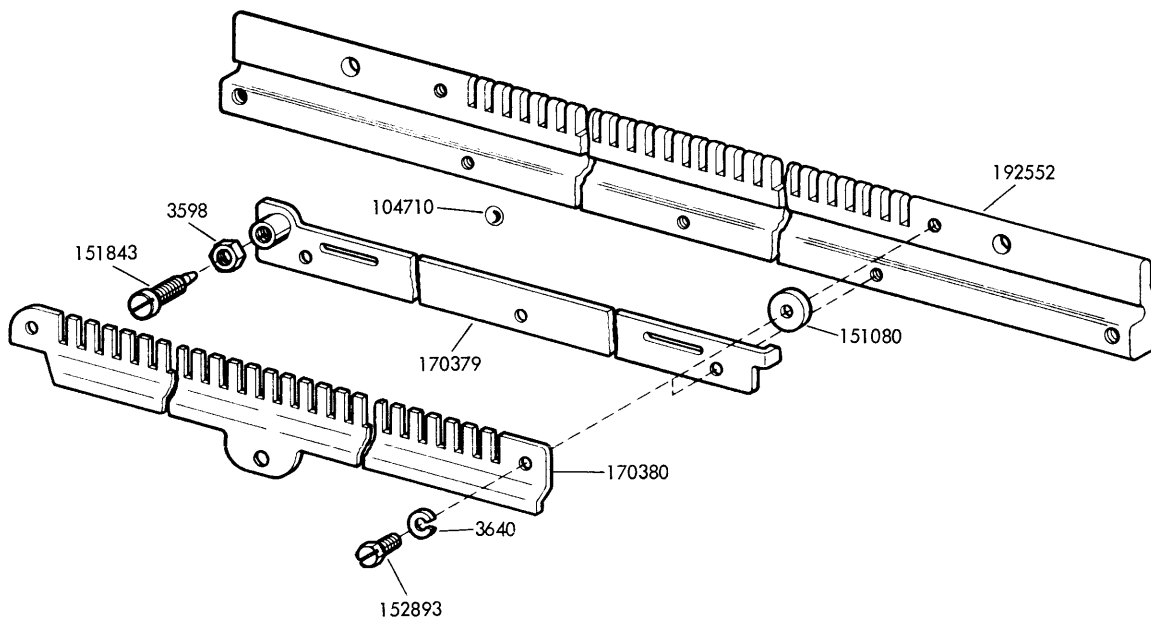
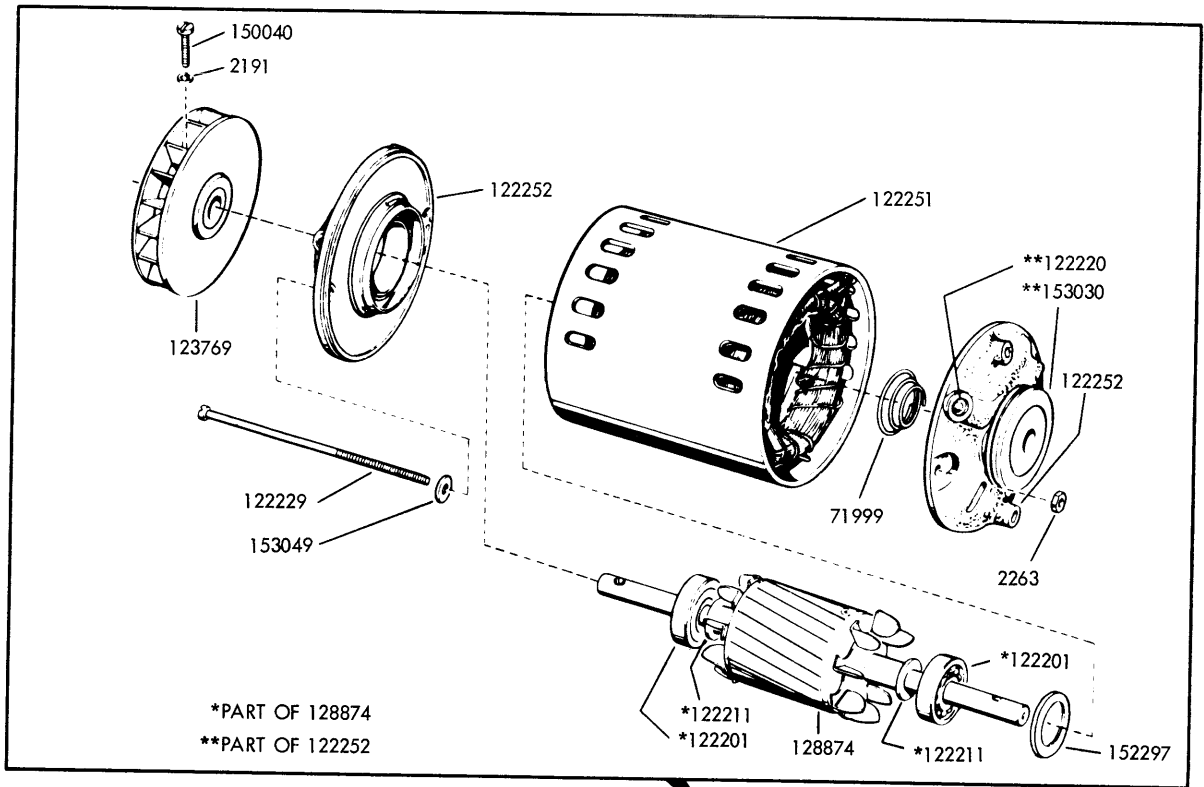


FIGURE 7A-4. BALL LOCK MECHANISM



178500 (1/20 H.P., 115V/1/60 Cycle,  
A.C. Synchronous Motor—G.E. Model 5SC19LG15)

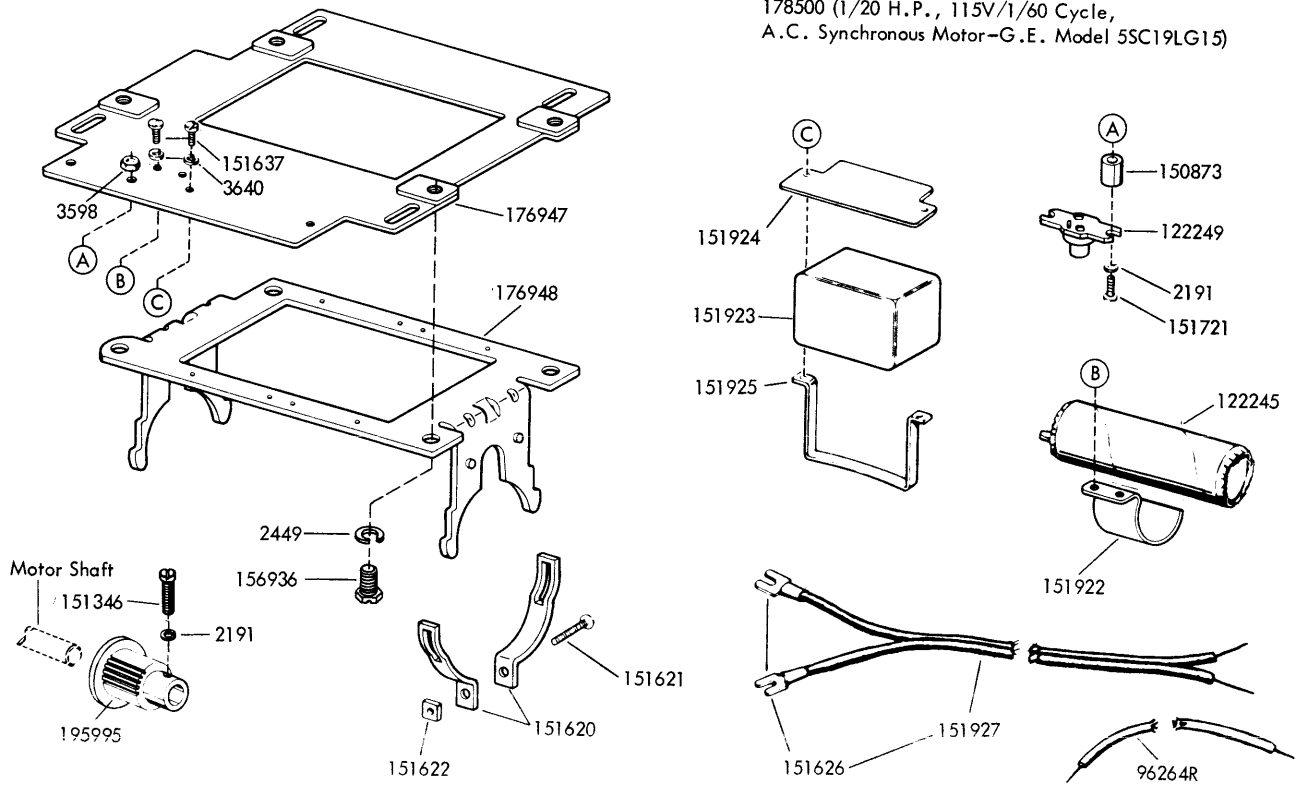


FIGURE 7A-5. LMU27 SYNCHRONOUS MOTOR UNIT

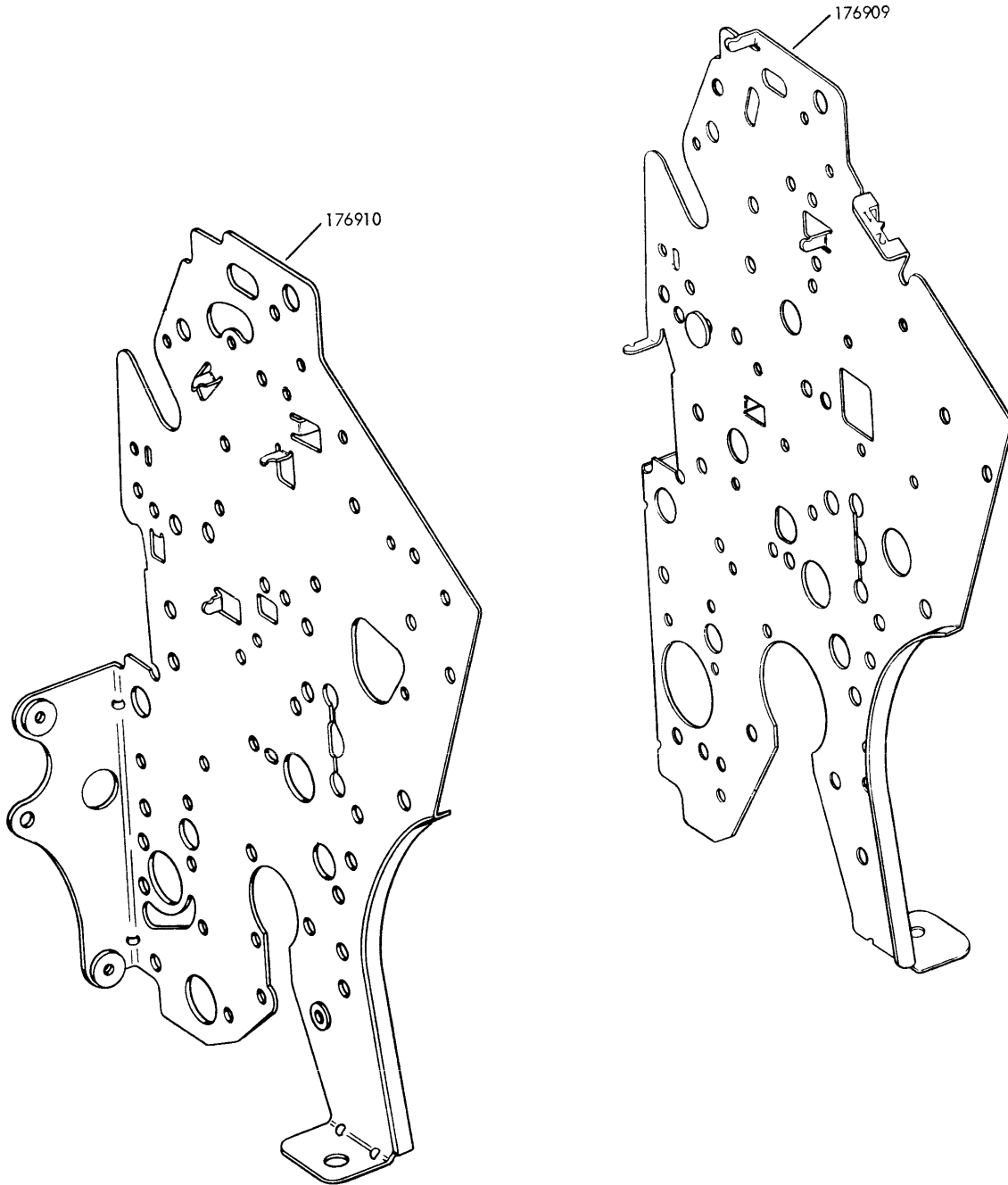
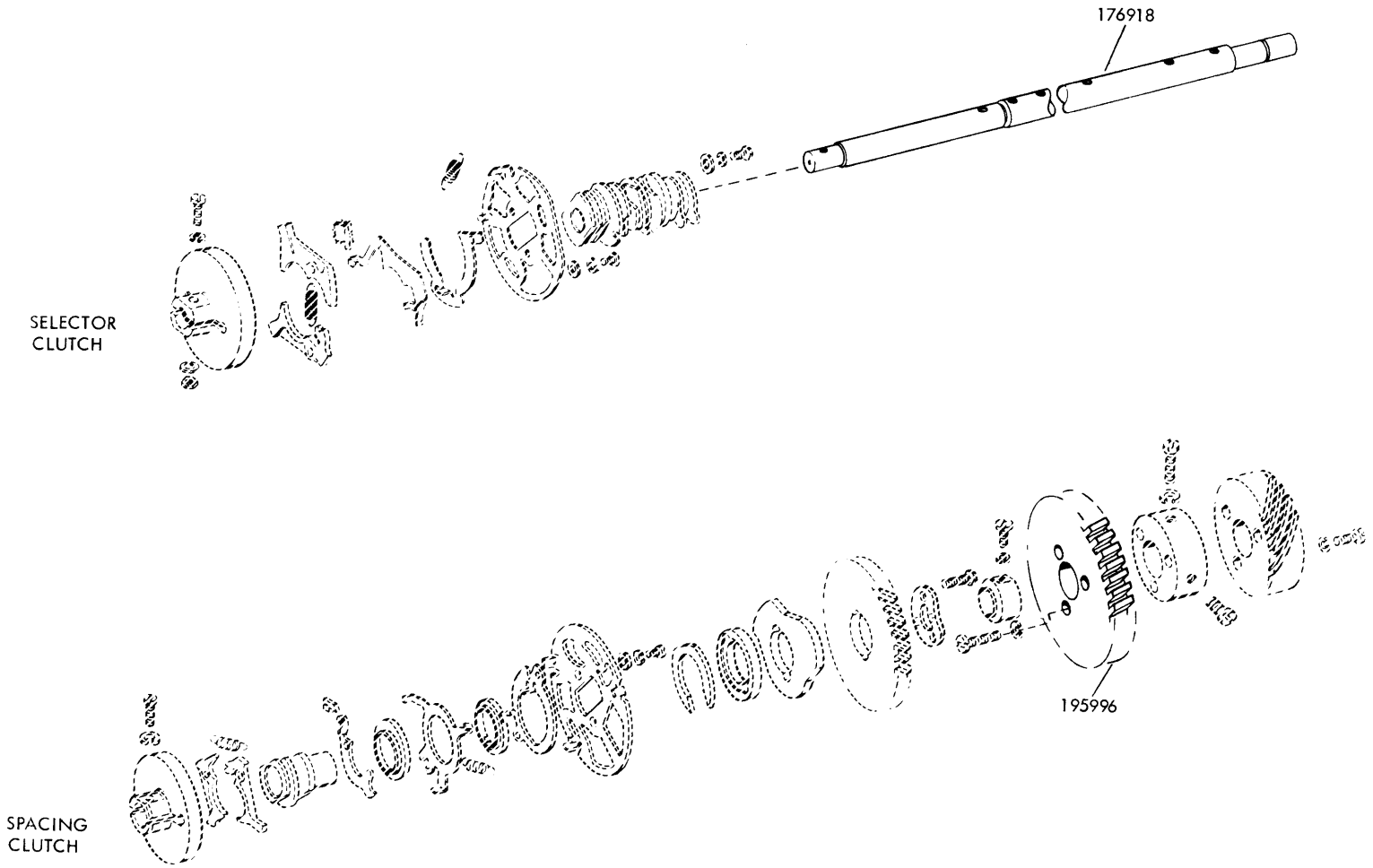
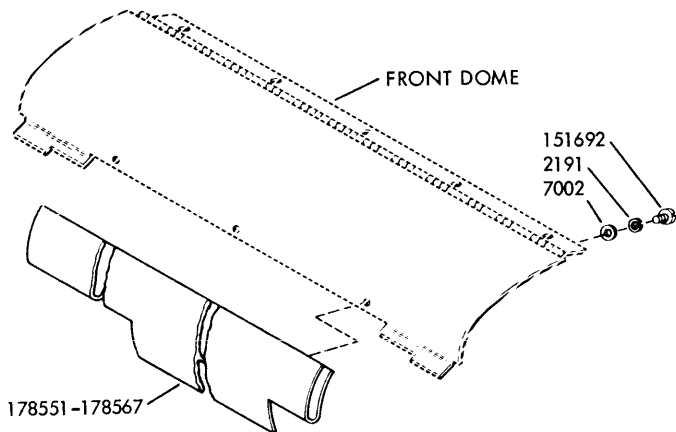
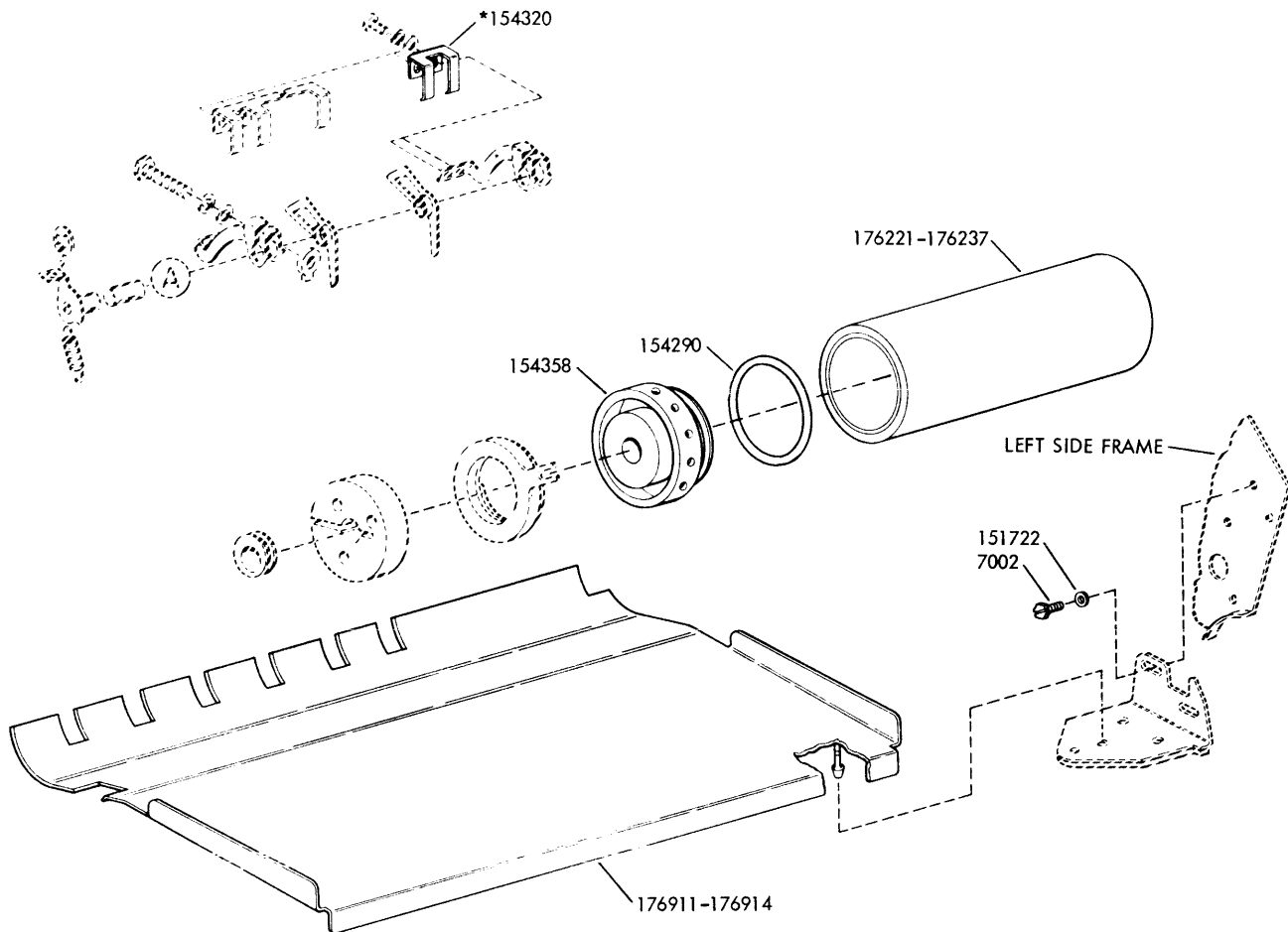


FIGURE 7A-6. RIGHT AND LEFT SIDE FRAMES

FIGURE 7A-7. MAIN SHAFT MECHANISM



For dotted parts, see  
Figs. 3-18 and 3-19



Paper Widths	Paper Tray	Mod. Kit Paper Handling Parts		
		Kit No.	Platen	Form Guide
9"	176912	178568	176221	178551
8-1/2"	176911	178569	176222	178552
8"	176912	178570	176223	178553
7-1/2"	176911	178571	176224	178554
7"	176912	178572	176225	178555
6-1/2"	176911	178573	176226	178556
6-3/8"	176913	178574	176227	178557
6-1/4"	176914	178575	176228	178558
6"	176912	178576	176229	178559
5-3/4"	176913	178577	176230	178560
5-1/2"	176911	178578	176231	178561
5"	176912	178579	176232	178562
4-1/2"	176911	178580	176233	178563
4-5/16"	176914	178581	176234	178564
4-1/4"	176913	178582	176235	178565
4"	176912	178583	176236	178566
3-5/8"	176911	178584	176237	178567

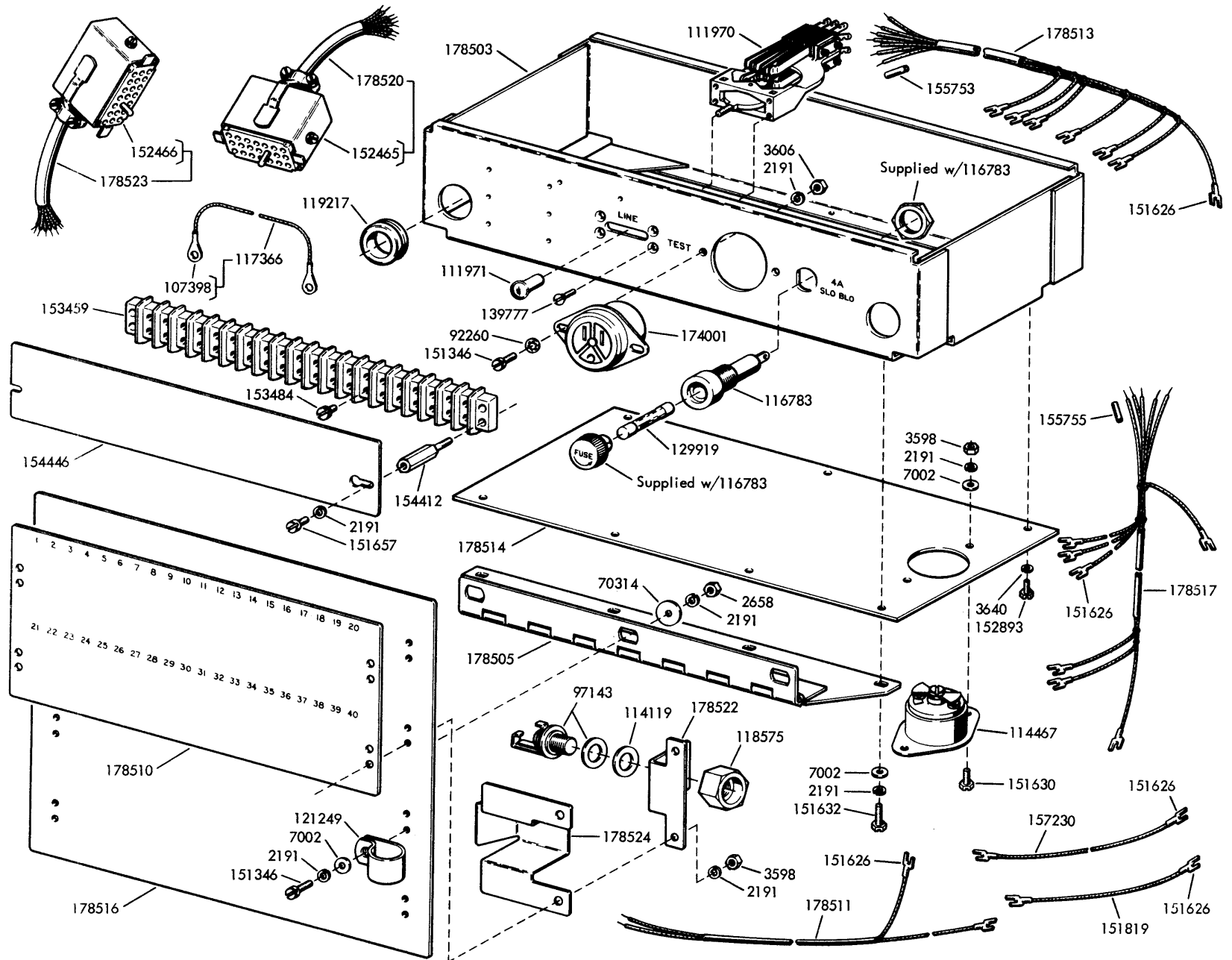
\*Peculiar to Units Using Paper Widths of 4-1/4" or Narrower

For Dotted Parts, See Figure 3-12 and 7A-16.

FIGURE 7A-8. SPROCKET FEED PAPER HANDLING MODIFICATION KITS



FIGURE 7A-9. ELECTRICAL SERVICE UNIT



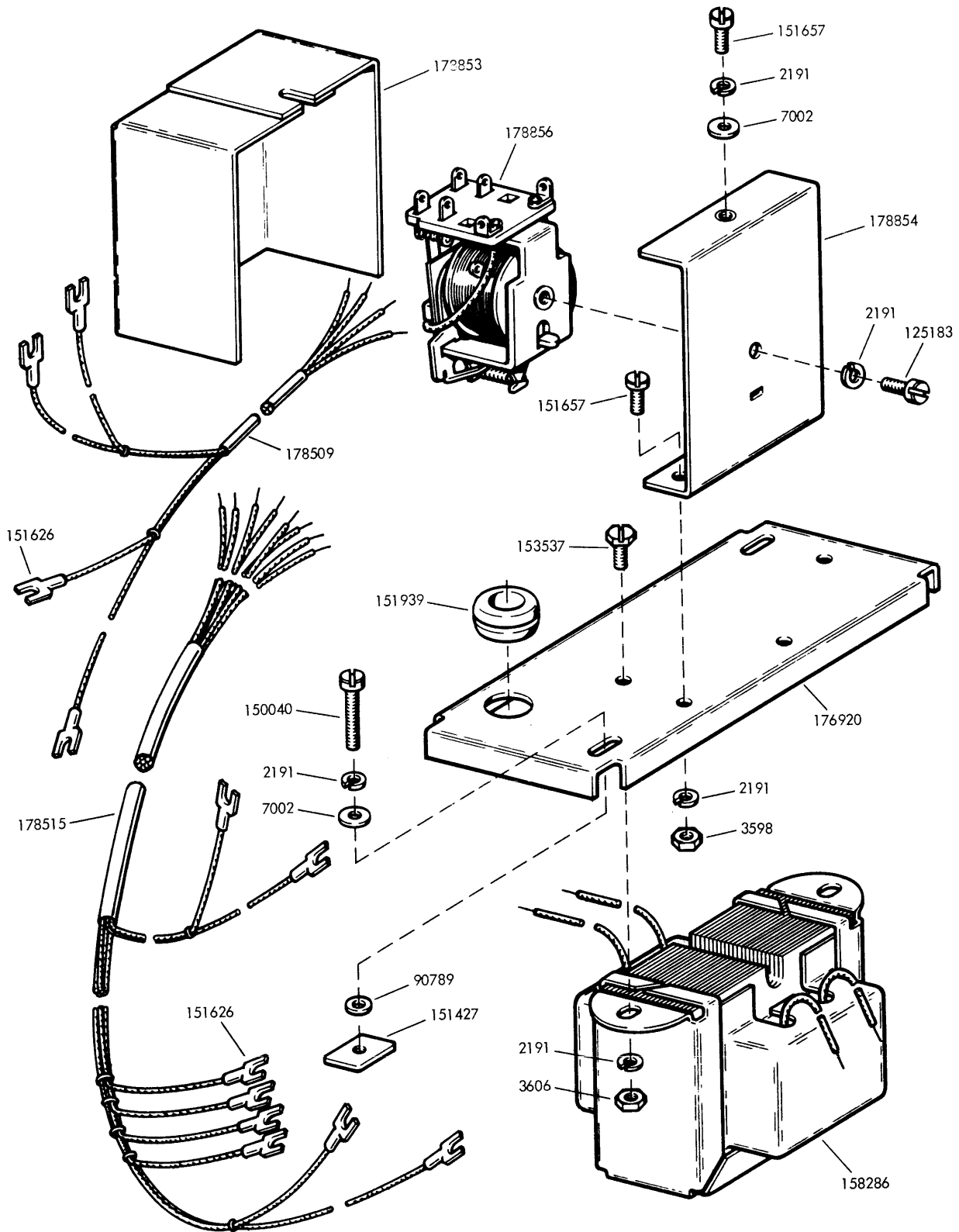


FIGURE 7A-10. 176921 TRANSFORMER AND RELAY ASSEMBLY

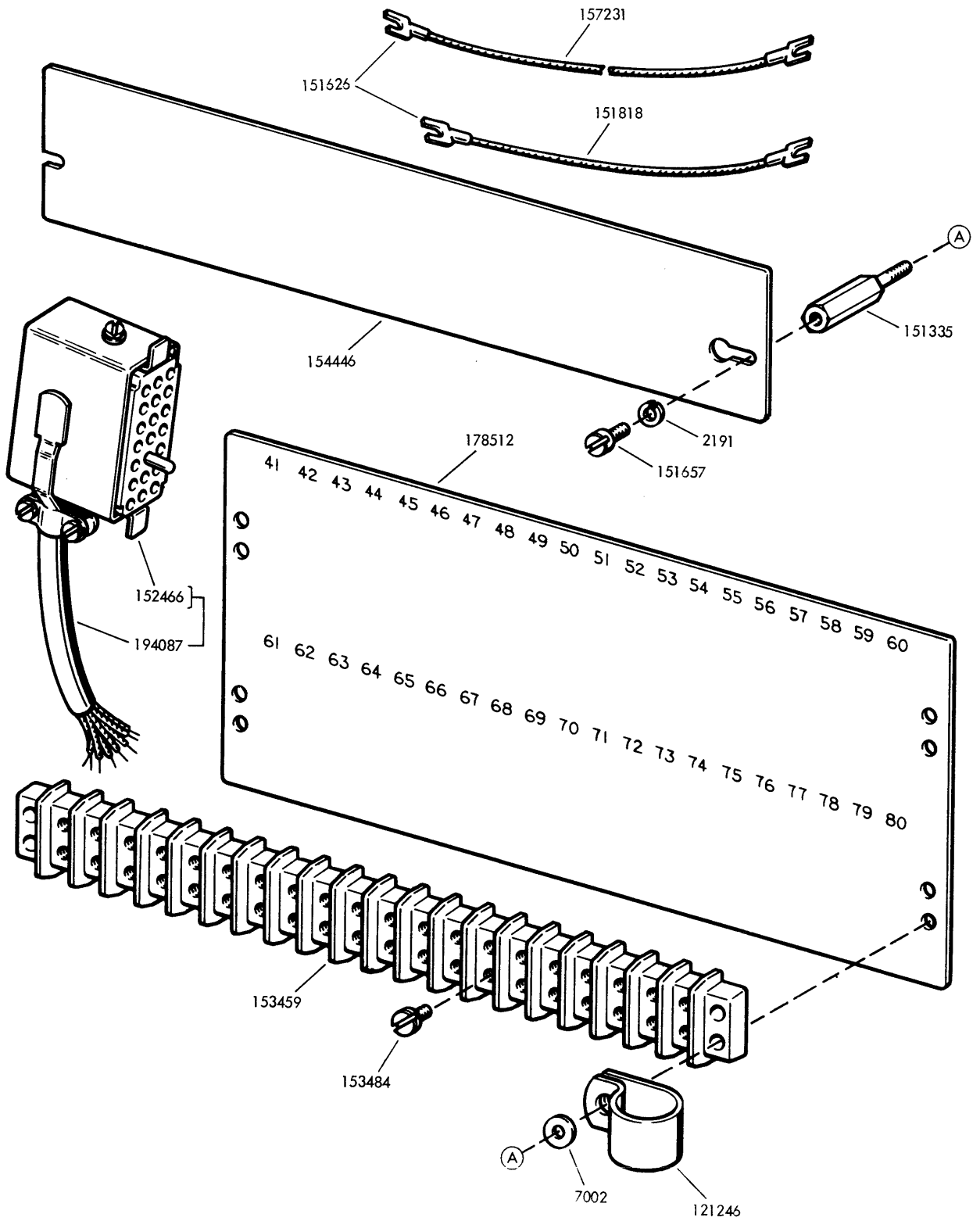


FIGURE 7A-11. 194086 MODIFICATION KIT TO ADAPT WALL MOUNTED PRINTER FOR SELECTIVE CALLING

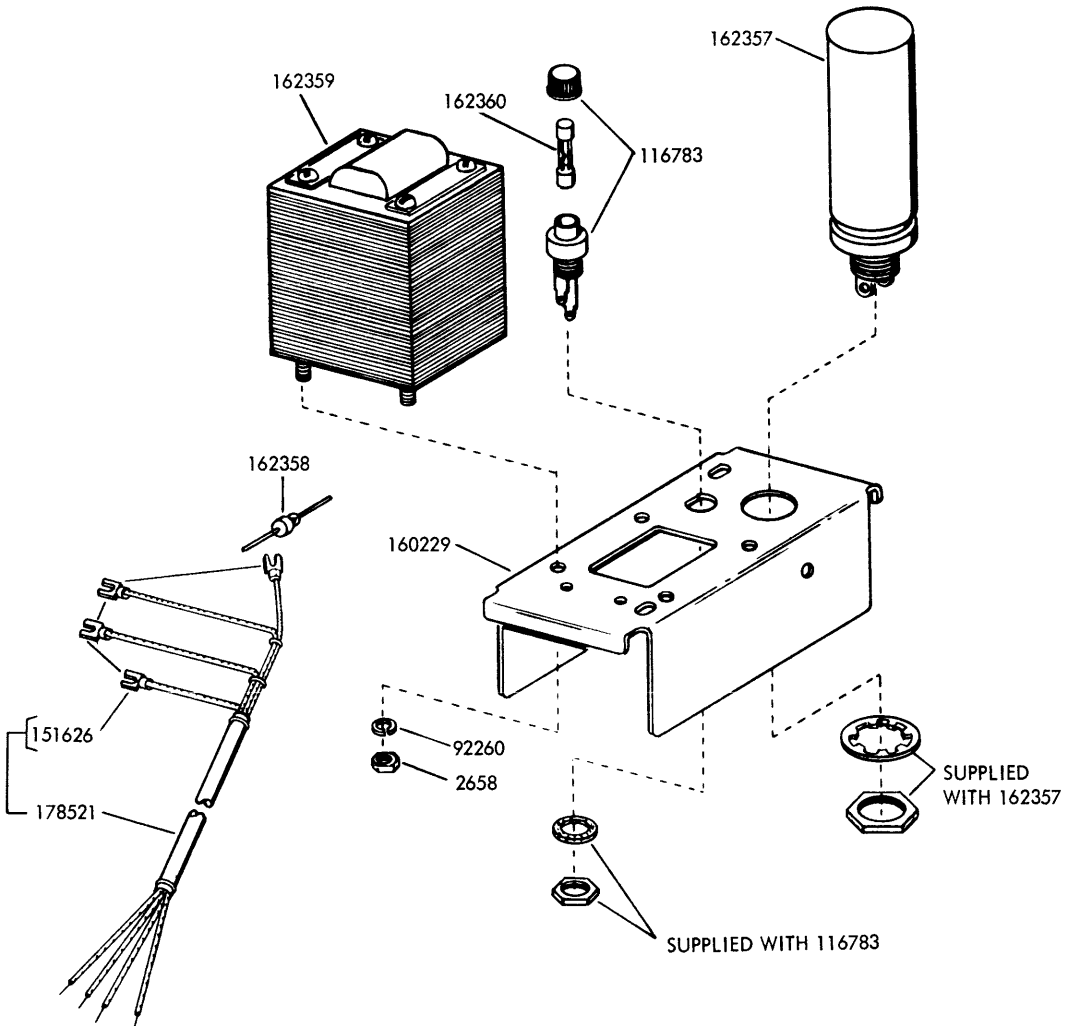
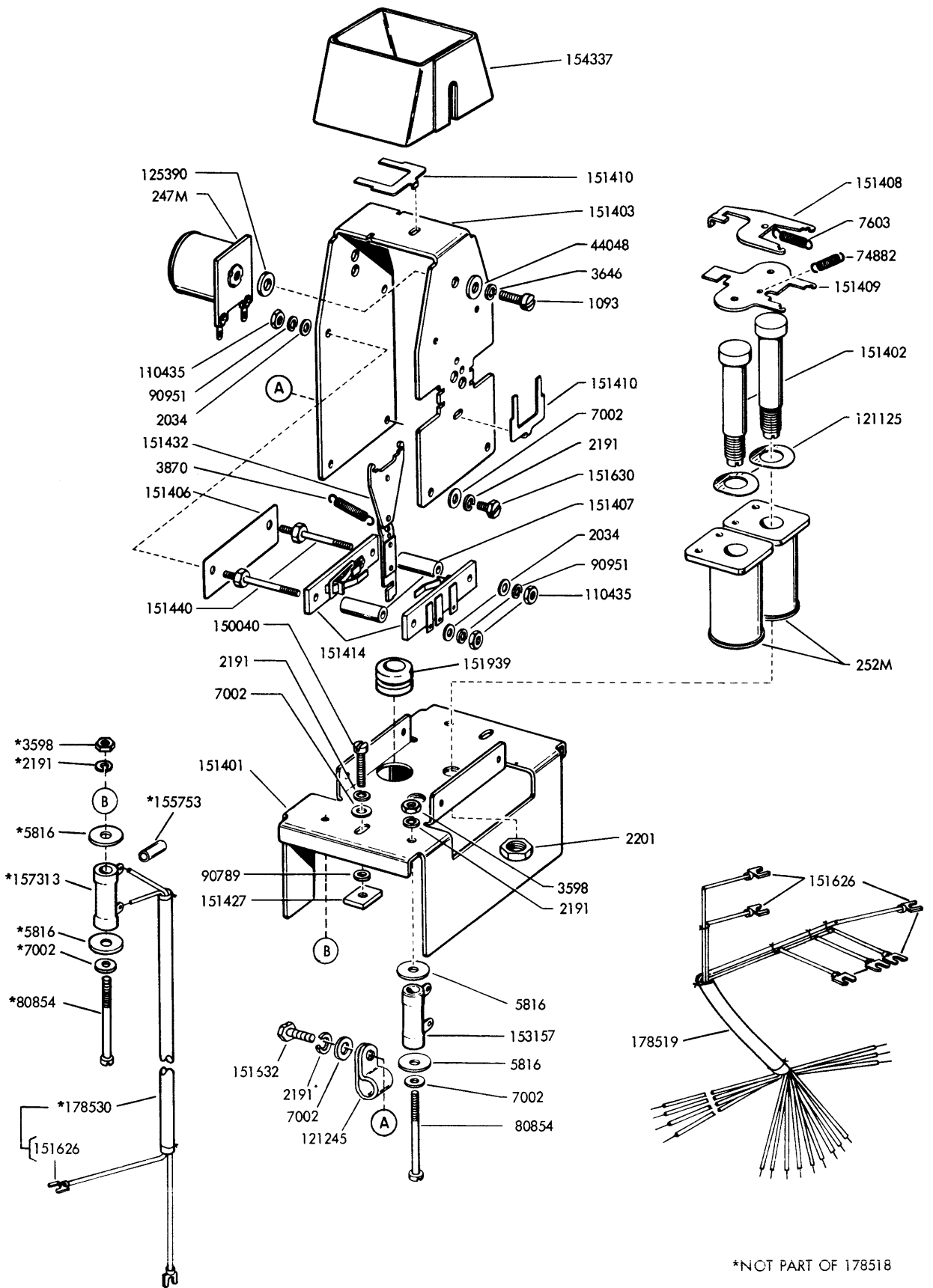


FIGURE 7A-12. 176985 RECTIFIER AND CABLE ASSEMBLY (500 MA)

1149B



\*NOT PART OF 178518

FIGURE 7A-13. 178518 MOTOR CONTROL ASSEMBLY

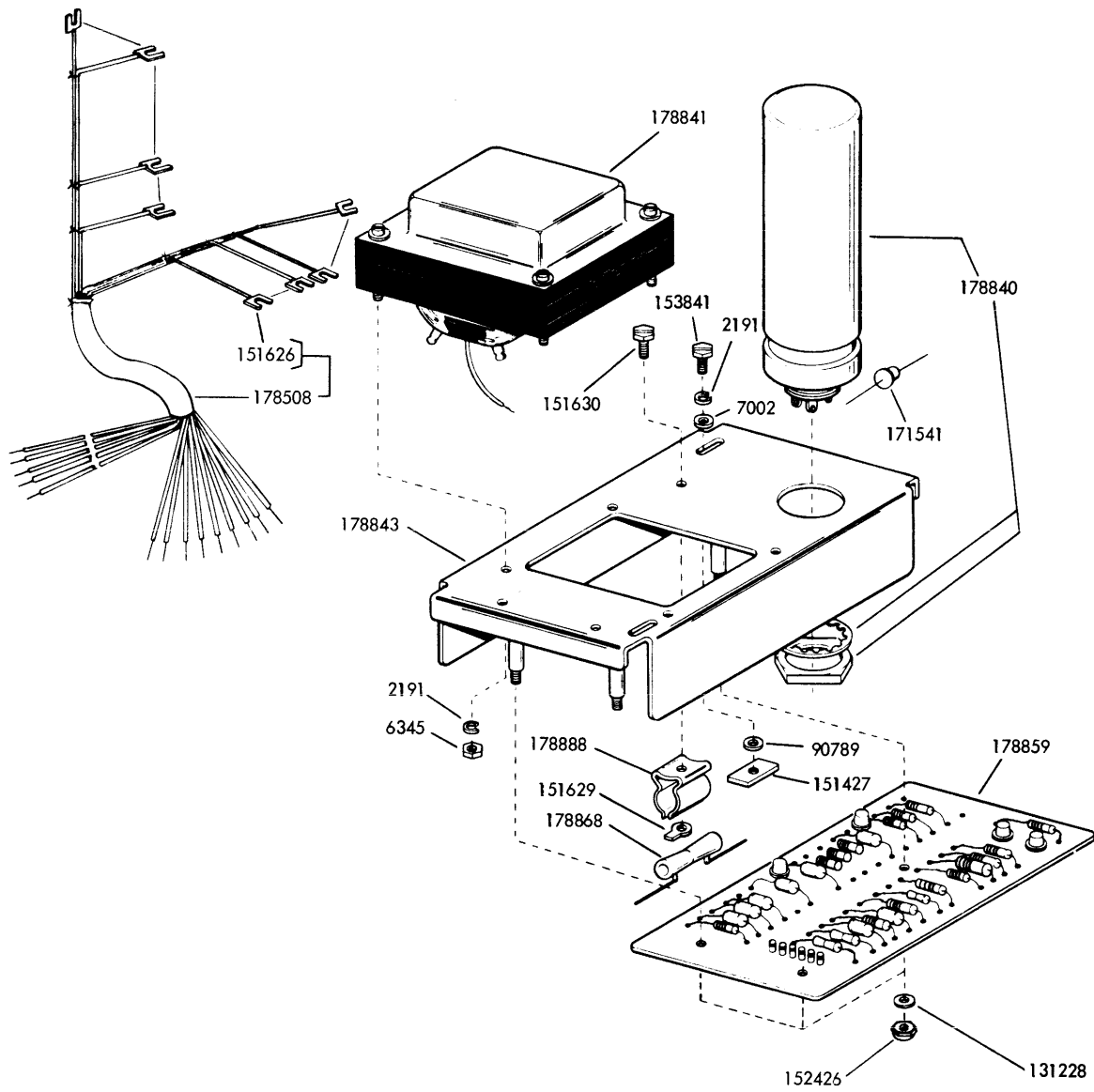


FIGURE 7A-14. 178507 SELECTOR MAGNET DRIVER ASSEMBLY

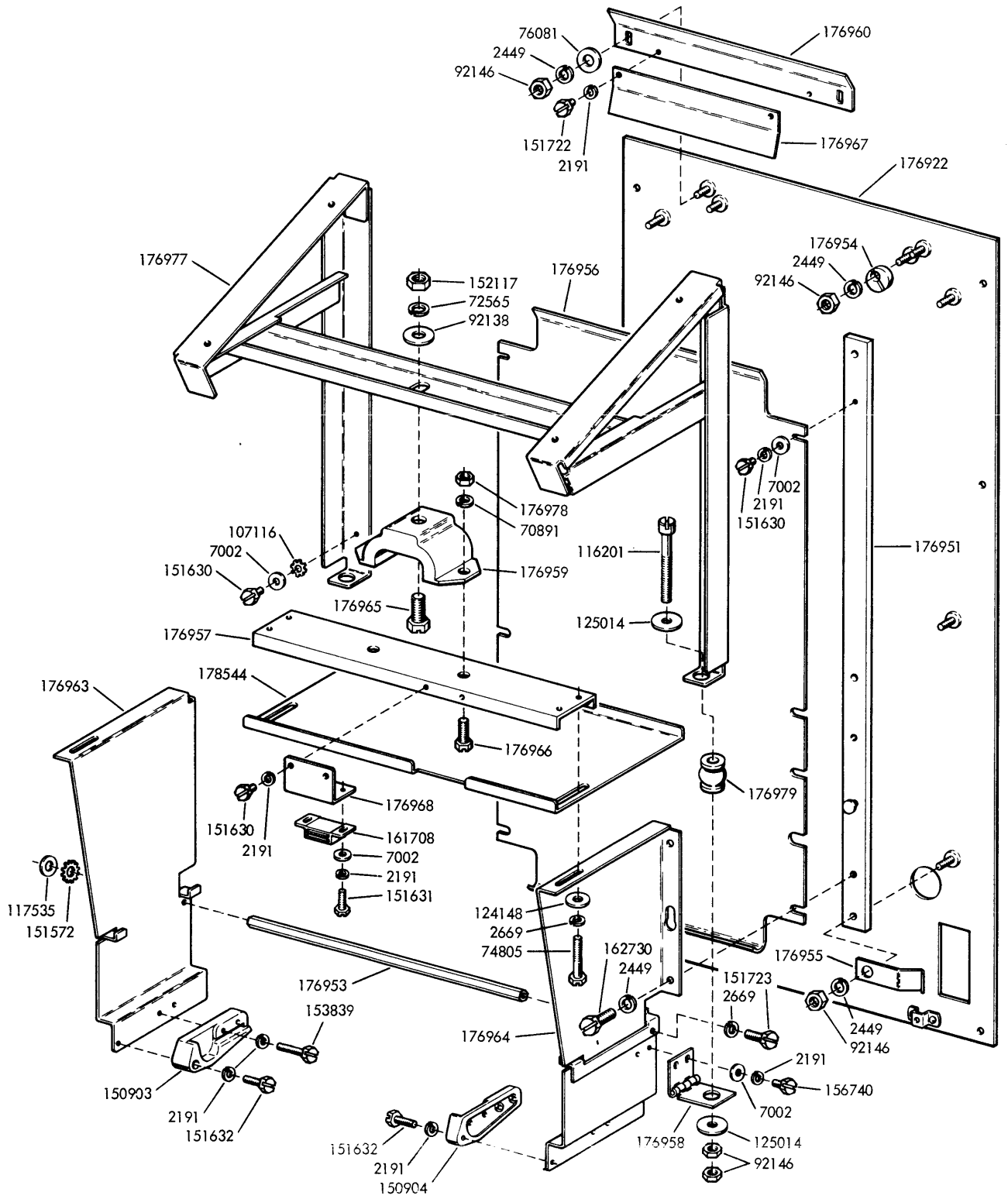
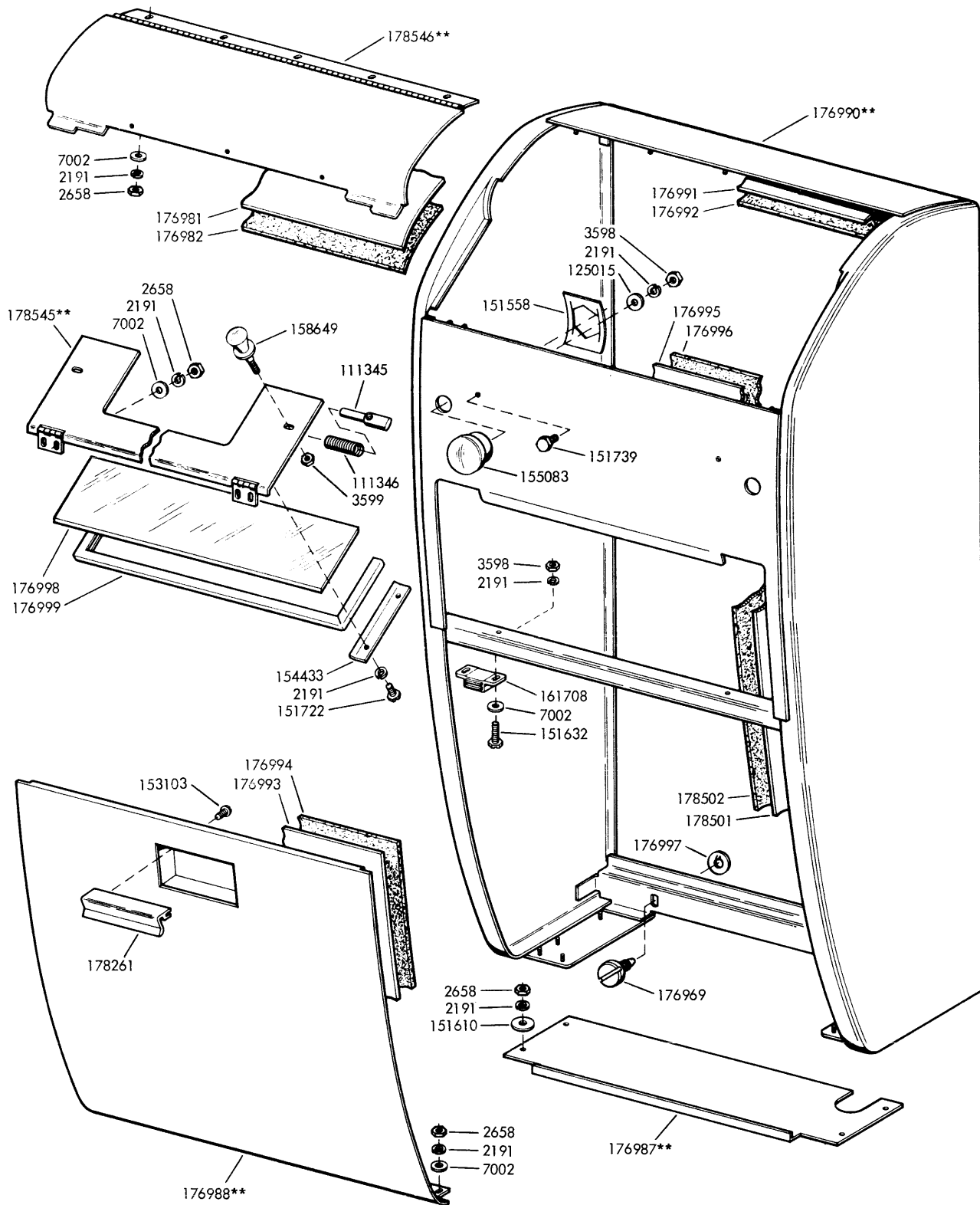


FIGURE 7A-15. BACK PLATE ASSEMBLY



\*\*See chart on page J for color suffix

FIGURE 7A-16. WALL MOUNTED CABINET



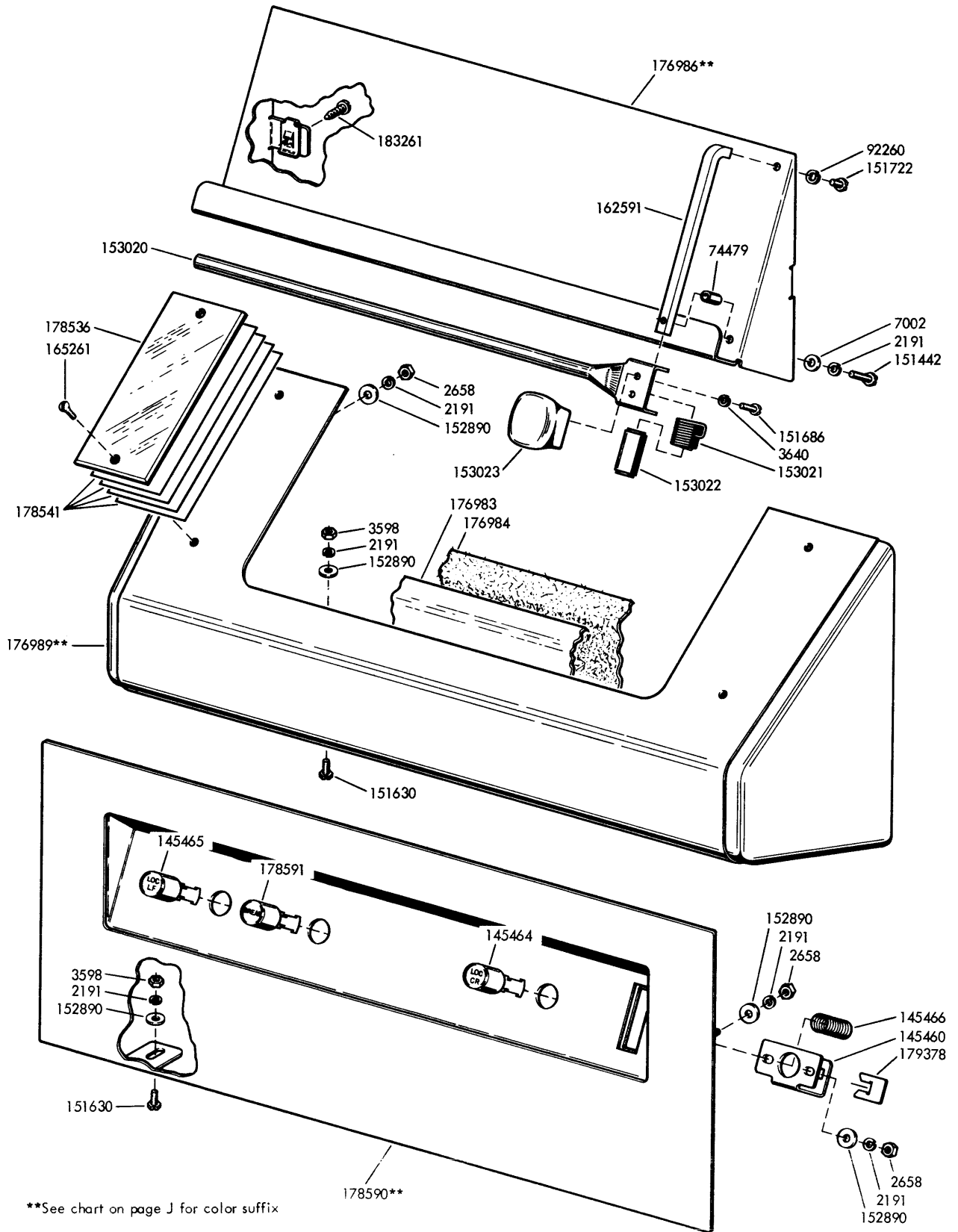


FIGURE 7A-17. COPYHOLDER TRAY, HOOD AND FRONT PLATE

## NUMERICAL INDEX - SECTION 7A

Part Number	Description and Page Number	Part Number	Description and Page Number	Part Number	Description and Page Number
247M	Coil, Magnet 7A-2,7A-13	116201	Screw (1/4-20 x 1-1/2 Fil) 7A-15	151558	Nut, Speed 7A-16
252M	Coil, Magnet 7A-13	116783	Holder, Fuse 7A-9,7A-12	151564	Bracket 7A-2
1026	Screw (6-40 x 3/8 Fil) 7A-2	117366	Strap w/Terminals 7A-9	151565	Bushing, Shoulder 7A-2
1028	Screw (4-40 x 1/4 Fil) 7A-2	117535	Washer, Flat 7A-15	151567	Armature w/Clapper 7A-2
1093	Screw (8-32 x 7/16 Fil) 7A-13	118575	Nut, Insulating (3/8-32 Hex) 7A-9	151572	Washer, Lock 7A-15
2034	Washer, Flat 7A-13	119217	Grommet, Rubber 7A-9	151574	Grommet, Rubber 7A-2
2191	Washer, Lock 7A-2 to 7A-5,7A-8 to 7A-11,7A-13 to 7A-17	119653	Ring, Retaining 7A-4	151577	Screw, Shoulder (6-40) 7A-2
2201	Nut (5/16-32) 7A-13	119655	Ring, Retaining 7A-2	151579	Plate, Retaining 7A-2
2263	Nut (8-32 Hex) 7A-5	121125	Washer, Spring 7A-13	151610	Washer, Flat 7A-16
2449	Washer, Lock 7A-2,7A-5,7A-15	121245	Clamp, Cable (5/16" ID) 7A-13	151620	Strap, Mounting 7A-5
2658	Nut (6-32 Hex) 7A-9,7A-12,7A-16,7A-17	121246	Clamp, Cable (3/8" ID) 7A-11	151621	Screw (6-32 x 3/4 Rd) 7A-5
2669	Washer, Lock 7A-2,7A-15	121249	Clamp, Cable (5/8" ID) 7A-9	151622	Nut (6-32 Sq) 7A-5
3438	Washer, Flat 7A-2	121539	Terminal 7A-2	151626	Terminal 7A-3 to 7A-5,7A-9 to 7A-14
3595	Nut (1/4-32 Hex) 7A-2	122201	Bearing, Ball 7A-5	151629	Nut (6-40 Lug) 7A-14
3598	Nut (6-40 Hex) 7A-2 to 7A-5,7A-9,7A-10,7A-13,7A-16,7A-17	122211	Washer, Pull 7A-5	151630	Screw (6-40 x 1/4 Hex) 7A-2 to 7A-4,7A-9,7A-13 to 7A-15,7A-17
3599	Nut (4-40 Hex) 7A-16	122220	Oiler 7A-5	151631	Screw (6-40 x 5/16 Hex) 7A-2,7A-3,7A-15
3606	Nut (6-40 Hex) 7A-9,7A-10	122229	Bolt (8-32) 7A-5	151632	Screw (6-40 x 3/8 Hex) 7A-2,7A-3,7A-9,7A-13,7A-15,7A-16
3640	Washer, Lock 7A-2,7A-4,7A-5,7A-9,7A-17	122245	Capacitor (43-45 mfd) 7A-5	151637	Screw (4-40 x 1/4 Fil) 7A-5,7A-9
3646	Washer, Lock 7A-2,7A-13	122249	Switch, Thermostatic 7A-5	151657	Screw (6-40 x 1/4 Fil) 7A-10,7A-11
3870	Spring 7A-13	122251	Stator 7A-5	151658	Screw (6-40 x 5/16 Fil) 7A-2
4703	Spring 7A-2	122252	Shield Assembly, End 7A-5	151659	Screw (6-40 x 1/2 Fil) 7A-3
5816	Washer,Insulating 7A-13	123769	Fan 7A-5	151686	Screw (4-40 x 3/8 Fil) 7A-17
6345	Nut (6-32 Hex) 7A-14	124148	Washer, Flat 7A-15	151692	Screw (6-40 x 3/16 Fil) 7A-8
7002	Washer, Flat 7A-2 to 7A-4,7A-8 to 7A-11,7A-13 to 7A-17	125014	Washer, Flat 7A-15	151721	Screw (6-40 x 3/4 Hex) 7A-5
7603	Spring 7A-13	125015	Washer, Flat 7A-2,7A-3,7A-16	151722	Screw (6-40 x 3/16 Hex) 7A-8,7A-15 to 7A-17
8330	Washer, Flat 7A-3	125183	Screw (6-32 x 5/16 Fil) 7A-10	151723	Screw (10-32 x 3/8 Hex) 7A-15
43954	Bell 7A-2	125231	Nut (10-32 Hex) 7A-2	151739**	Screw, Identification (6-40) 7A-16
44048	Washer, Flat 7A-13	125390	Washer, Flat 7A-13	151818	Jumper Assembly (4-1/4" Black) 7A-11
55219	Screw (8-32 x 3/8 Fil) 7A-2	128874	Rotor 7A-5	151819	Jumper Assembly (3-1/8 Black) 7A-9
70314	Washer, Flat 7A-9	129919	Fuse (4 Amp) 7A-9	151843	Screw, Adjusting (6-40) 7A-4
70891	Washer, Lock 7A-15	131099	Terminal 7A-2	151922	Clamp 7A-5
71999	Spring 7A-5	131228	Washer, Insulating 7A-14	151923	Relay 7A-5
72565	Washer, Lock 7A-15	139777	Screw (3-56 x 1/4 Flat) 7A-9	151924	Insulator 7A-5
74479	Bushing 7A-17	145318	Screw, Adjusting (6-40) 7A-4	151925	Clamp 7A-5
74805	Screw (10-32 x 3/4 Hex) 7A-15	145460	Bracket 7A-17	151927	Cord 7A-5
74882	Spring 7A-13	145464	Lever Assembly, Key (LOC CR) 7A-17	151939	Grommet, Rubber 7A-2,7A-10,7A-13
76081	Washer, Flat 7A-15	145465	Lever Assembly, Key (LOC LF) 7A-17	151982	Lamp, Incandescent (6V) 7A-2
80854	Screw (6-40 x 7/16 Fil) 7A-13	145466	Spring 7A-17	152117	Nut (1/2-13 Hex) 7A-15
86835	Spring 7A-2	150040	Screw (6-40 x 5/8 Fil) 7A-5,7A-10,7A-13	152297	Washer, Bearing 7A-5
90789	Washer, Flat 7A-10,7A-13,7A-14	150873	Collar 7A-5	152426	Nut, Self-Locking (6-40 Hex) 7A-14
90951	Washer, Lock 7A-13	150903	Block, Paper Spindle (Left) 7A-15	152461	Bracket 7A-2
91228	Strap 7A-2	150904	Block, Paper Spindle (Right) 7A-15	152462	Latch, Right 7A-2
91229	Wire, Braided 7A-2	150966	Insulator 7A-2	152463	Latch, Left 7A-2
92138	Washer, Flat 7A-15	151045	Bar, Space 7A-3	152464	Insulator 7A-2
92146	Nut (1/4-20 Hex) 7A-15	151080	Washer, Spacing 7A-4	152465	Connector, Receptacle (20 Pt) 7A-9
92260	Washer, Lock 7A-9,7A-12,7A-17	151223	Screw, Shoulder (4-40) 7A-3	152466	Connector, Receptacle (20 Pt) 7A-9
96264R	Wire, Connector (5" Red) 7A-5	151335	Stud 7A-2,7A-11	152467	Connector, Plug (20 Pt) 7A-2
97143	Jack 7A-9	151346	Screw (6-40 x 3/8 Fil) 7A-5,7A-9	152890	Washer, Flat 7A-2,7A-4,7A-17
104710	Bearing, Ball 7A-4	151401	Base 7A-13	152893	Screw (4-40 x 1/4 Hex) 7A-4,7A-9
104827	Bearing, Ball 7A-2	151402	Core 7A-13	153020	Guide, Line 7A-17
107116	Washer, Lock 7A-15	151407	Frame 7A-13	153021	Spring 7A-17
107364	Screw (6-32 x 3/8 Oval) 7A-3	151408	Plate, Insulating 7A-13	153022	Bushing 7A-17
107398	Terminal 7A-2,7A-9	151409	Collar 7A-13	153023	Handle 7A-17
110434	Screw (4-40 x 3/16 Fil) 7A-2	151408	Lever 7A-13	153030	Mount, Vibration 7A-5
110435	Nut (4-40 Hex) 7A-2,7A-13	151409	Armature 7A-13	153049	Washer, Fiber 7A-5
111017	Screw (6-40 x 5/16 Fil) 7A-2	151410	Clip, Retaining 7A-13	153103	Screw, Self-Tapping (4-40) 7A-16
111345	Bolt, Latch 7A-16	151414	Switch, Sensitive 7A-13	153157	Resistor (400 Ohm) 7A-13
111346	Spring 7A-16	151415	Block, Terminal 7A-2		
111767	Washer, Flat 7A-2	151416	Nut (6-40 Hex) 7A-2		
111970	Key, Line Test 7A-9	151427	Plate, Clamp 7A-10,7A-13,7A-14		
111971	Knob 7A-9	151432	Armature 7A-13		
114119	Washer, Insulating 7A-9	151440	Stud 7A-13		
114467	Connector, Plug (2 Pt) 7A-9	151442	Screw (6-40 x 1/2 Hex) 7A-17		
		151540	Lampholder 7A-2		

## NUMERICAL INDEX - SECTION 7A (Continued)

Part Number	Description and Page Number	Part Number	Description and Page Number	Part Number	Description and Page Number
153441	Screw (10-32 x 7/16 Hex) 7A-2	176940	Plate, Nut 7A-2	178519	Cable Assembly (Motor Control) 7A-13
153459	Block, Terminal 7A-9,7A-11	176941	Plate, Nut 7A-2	178520	Cable Assembly (Keyboard Connector) 7A-9
153484	Screw (6-32 x 1/4 Rd) 7A-9	176944	Plate, Nut 7A-2	178521	Cable Assembly 7A-12
153537	Screw (6-40 x 9/32 Hex) 7A-10	176945	Bracket 7A-2	178522	Bracket, Mounting 7A-9
153839	Screw (6-40 x 5/8 Hex) 7A-15	176947	Plate w/Pads 7A-5	178523	Cable Assembly (Printer Connector) 7A-9
153841	Screw (6-40 x 9/16 Hex) 7A-3, 7A-14 *	176948	Bracket, Motor 7A-5	178524	Insulator 7A-9
154156	Grommet, Rubber 7A-2	176951	Bar, Vertical Mounting 7A-15	178525	Cable Assembly 7A-2
154173	Plate 7A-2	176953	Bar 7A-15	178526	Cable Assembly (Line Break Key) 7A-2
154290	Ring, "O" 7A-8	176954	Eccentric 7A-15	178530	Cable Assembly 7A-13
154320	Finger, Paper-Left 7A-8	176955	Clip, Spring 7A-15	178536	Window, Plastic 7A-17
154337	Cover 7A-13	176956	Chute, Paper 7A-15	178541	Label Set 7A-17
154358	Hub, Platen 7A-8	176957	Bar, Lower Support 7A-15	178544	Tray, Oil 7A-15
154412	Stud (6-40) 7A-9	176958	Hinge 7A-15	178545**	Door, Window 7A-16
154433	Clamp 7A-16	176959	Isolator 7A-15	178546**	Dome, Front 7A-16
154446	Cover 7A-9,7A-11	176960	Bar, Cover Mounting 7A-15	178547	Plate, Nut 7A-2
155083	Lens, Indicator Light (Red) 7A-16	176963	Plate, Left Side 7A-15	178549	Bumper, Rubber 7A-2
155753	Sleeve, Insulating (1/8 x 1/2 ID) 7A-9,7A-13	176964	Plate, Hood (Outer) 7A-15	178551	to Form, Guide 7A-8
155755	Sleeve, Insulating (11/64 x 5/8 ID) 7A-9	176965	Screw (1/2-13 x 1" Hex) 7A-15	178567	178568
156632	Screw (6-40 x 13/32 Hex) 7A-3	176966	Screw (3/8-24 x 3/4" Hex) 7A-15	to	Modification Kits 7A-8
156740	Screw (6-40 x 7/32 Fil) 7A-15	176967	Deflector, Paper 7A-15	178584	178588
156936	Screw (1/4-32 x 5/16 Hex) 7A-5	176968	Bracket 7A-15	178586	Bracket 7A-4
157230	Wire (6-1/4" Black) 7A-9	176969	Fastener, Screw 7A-16	178587	Bracket, Switch 7A-4
157231	Wire (8" Black) 7A-11	176977	Frame 7A-15	178588	Shaft 7A-4
157313	Resistor (1800 Ohm) 7A-13	176978	Nut (3/8-24 Hex) 7A-15	178589	Lever, Trip 7A-4
158163	Switch 7A-3	176979	Mount, Vibration 7A-15	178590**	Plate, Front 7A-17
158286	Transformer 7A-10	176981	Pad, Front Dome (Inner) 7A-16	178591	Lever Assembly, Key (Break) 7A-17
158649	Screw, Thumb (4-40) 7A-16	176982	Pad, Front Dome (Outer) 7A-16	178592	Bracket, Connector 7A-2
158745	Plate, Clamp 7A-2	176983	Pad, Hood (Inner) 7A-17	178593	Cable Assembly 7A-4
160229	Plate, Mounting 7A-12	176984	Pad, Hood (Outer) 7A-17	178714	Switch 7A-4
161708	Latch, Magnet 7A-15,7A-16	176985	Rectifier 7A-12	178840	Capacitor (400 mfd) 7A-14
162357	Capacitor (500 mfd) 7A-12	176986**	Tray, Copyholder 7A-17	178841	Transformer 7A-14
162358	Diode (Silicon) 7A-12	176987**	Plate, Bottom 7A-16	178843	Plate, Mounting 7A-14
162359	Transformer, Power 7A-12	176988**	Door 7A-16	178853	Cover, Relay 7A-10
162360	Fuse (8/10 Amp) 7A-12	176989**	Hood 7A-17	178854	Bracket, Relay 7A-10
162591	Shaft 7A-17	176990**	Cover 7A-16	178856	Relay 7A-10
162730	Screw (1/4-20 x 7/16 Hex) 7A-15	176991	Pad, Rear Dome (Inner) 7A-16	178859	Card, Circuit 7A-14
165261	Screw (4-40 x 3/8 Oval) 7A-17	176992	Pad, Rear Dome (Outer) 7A-16	178868	Resistor (700 Ohm) 7A-14
170379	Retainer, Ball 7A-4	176993	Pad, Door 7A-16	178888	Clip 7A-14
170380	Retainer, Wedge 7A-4	176994	Pad, Door 7A-16	179372	Shield, Light 7A-2
171541	Diode, Silicon 7A-14	176995	Pad, Front (Inner) 7A-16	179378	Retainer, Keylever 7A-17
171721	Shaft, Stop Lever 7A-5	176996	Pad, Front (Outer) 7A-16	183261	Screw, Self-Tapping (#8A) 7A-17
174001	Connector, Receptacle (3 Pt) 7A-9	176997	Retainer 7A-16	192552	Channel, Ball 7A-4
176221	to Platen 7A-8	176998	Window 7A-16	192553	Bracket, Mounting (Left) 7A-3
176237	176999	176999	Gasket, Window 7A-16	192554	Bracket, Mounting (Right) 7A-3
176900	Base 7A-2	178261	Handle, Door 7A-16	192556	Frame 7A-3
176906	Plate, Keypop Guide 7A-3	178500	Motor, AC Synchronous 7A-5	192557	Grommet 7A-3
176907	Switch, Rocker 7A-3	178501	Pad, Side (Inner) 7A-16	193723	Clip, Spring 7A-2
176908	Shaft 7A-2	178502	Pad, Side (Outer) 7A-16	194086	Modification Kit 7A-11
176909	Frame, Left Side 7A-6	178503	Base 7A-9	194087	Cable Assembly 7A-11
176910	Frame, Right Side 7A-6	178504	Cable Assembly 7A-3	195992	Belt, Timing 7A-2
176911	to Guide, Paper 7A-8	178505	Hinge 7A-9	195993	Gear - 75 WPM (26T) 7A-2
176914	178507	178507	Magnet Assembly 7A-14	195994	Pulley (34T) 7A-2
176918	Shaft 7A-7	178508	Cable Assembly 7A-14	195995	Pulley (12T) 7A-5
176920	Plate, Mounting 7A-10	178509	Cable Assembly (Copy Light Transformer) 7A-10	195996	Gear (63T) 7A-7
176921	Relay Assembly 7A-10	178510	Cable Assembly (Line Jack) 7A-9	195997	Gear - 100 WPM (34T) 7A-2
176922	Plate, Back 7A-15	178511	Cable Assembly (Line Test) 7A-9	195999	Gear - 60 WPM (21T) 7A-2
176923	Plate, Vibration 7A-2	178512	Insulator (Bottom) 7A-11		
176924	Plate, Nut 7A-2	178513	Cable Assembly (Line Test Key) 7A-9		
176929	Retainer, Belt 7A-2	178514	Plate, Bottom 7A-9		
176932	Plate, Upper Bearing 7A-2	178515	Cable Assembly (Line Shunt Relay) 7A-10		
176933	Stud 7A-2	178516	Plate w/Studs 7A-9		
176936	Bracket - Left 7A-2	178517	Cable Assembly (AC) 7A-9		
176937	Bracket - Right 7A-2	178518	Control Assembly, Motor 7A-13		

**SECTION 8**  
**MASTER NUMERICAL INDEX**

1149B

NUMERICAL INDEX

Part Number	Page	Part Number	Page	Part Number	Page	Part Number	Page
169M	6-13	3339	2-14	7965	1-4, 3-9, 3-68	70529	3-90
190M	3-89	3340	2-14	8262	1-27, 6-24	70593	5-28, 5-32
194M	2-24	3438	1-6, 1-7, 2-2, 2-3, 3-76, 3-92, 5-2, 5-3,	8330	1-27, 2-3, 2-4, 2-14, 2-27, 3-2, 3-13, 3-22, 3-25, 3-31, 3-33, 3-41, 3-66, 3-71, 3-83, 3-94, 4-7, 5-30, 7-7	70866	5-39
209M	3-80		5-4, 5-7, 5-8, 5-14, 5-15, 5-29, 5-33, 5-39, 5-41, 5-44, 6-7, 6-9, 6-10, 7-7	8333	5-2, 5-3, 5-4, 5-14, 5-15	70887	6-23
224M	2-27		1-10, 6-13	8449	2-11, 2-21, 3-22, 3-38, 4-5, 7-13	71047	6-13
247M	5-3, 5-4, 5-15, 5-29, 6-5, 6-26 3-35, 3-36	3595	(Sev.)	8669	5-53	71073	1-10, 1-20, 2-22, 3-94, 6-22
250M	2-20, 6-5	3598	(Sev.)	9695	6-13	71155	6-6
252M	3-35	3599	(Sev.)	13681	3-2, 3-94	71646	6-6
254M	2-20	3606	1-8, 1-25, 2-11, 2-16, 2-21, 3-32, 3-34, 3-47, 4-7, 5-52, 6-2, 6-3, 6-25	22015	3-38, 3-48	71659	2-21
263M	3-4		6-13	25123	5-41, 5-42, 5-55	71681	3-37
1010	6-27		2-24, 4-5	27263	1-24	71858	5-3, 5-4, 5-15
1018	2-10		5-2, 5-3, 5-4, 5-12, 5-13, 5-14, 5-15, 5-17, 5-29, 7-7	31636	1-10, 1-20, 1-24, 2-21, 3-39, 3-64	71999	4-2, 4-3, 4-8
1020	3-89, 5-3, 5-4, 5-15, 6-8, 6-10, 6-11, 6-13, 6-25	3618	(Sev.)	33038	2-14, 3-8, 3-59	72468	3-6, 3-96, 7-15
1028	4-7	3624	1-13, 3-5, 3-90, 5-3, 5-4, 5-15, 5-29, 6-2, 6-5, 6-7, 6-15, 6-26, 6-27	33828	3-29	72522	3-49, 3-57, 3-60, 3-79, 3-88, 7-7, 7-9, 7-10, 7-12, 7-13, 7-17
1030	6-8, 6-10, 7-8, 5-41	3639	5-4, 5-15, 5-29, 6-2, 6-5, 6-7, 6-15, 6-26, 6-27	34432	1-27, 2-21, 3-63, 3-81, 3-82, 5-15, 6-4, 6-14, 6-16, 6-25	72563	1-11
1038	3-72		6-13	35503	5-28, 5-31, 5-32	72565	4-9, 5-26
1041	1-9, 1-18	3640	3-28, 3-31	35551	5-34, 5-41	72579	3-5, 3-90
1047	5-49	3646	6-11	35826	5-2, 5-14	72787	5-33
1079	6-5		2-2, 2-6, 2-8, 6-5	36273	3-29	73008	1-10, 2-11
1093	5-3, 5-4, 5-15		6-13	41325	1-24	73035	1-16, 2-17, 3-69
1113	3-89, 5-37	3647	1-27	41382	5-42	73175	3-10, 3-22, 3-71, 6-13
1118	6-2, 6-27	3649	3-8, 3-47	41663	1-27, 5-12, 5-39, 5-43	73374	4-5
1157	2-14	3650	2-8	41675	3-59, 3-84	73497	1-27
1161	6-10, 6-19	3650	1-7, 3-53, 3-57, 3-60, 3-79, 3-88, 3-93, 3-96, 5-3, 5-4, 5-15, 5-29, 6-26, 7-7, 7-9, 7-10, 7-12, 7-13, 7-17	41720	2-20, 3-82	73520	3-28
1162	1-13, 3-17, 3-18, 6-22	3870	6-26, 7-7, 7-9, 7-10, 7-12, 7-13, 7-17	41732	1-25, 2-20, 3-81, 3-82, 3-90, 3-93	73588	6-13
1164	6-20	3899	1-24, 6-25	41733	1-25, 3-82, 3-93	73592	6-13
1172	5-41	3949	3-2, 3-94	41832	3-33	73593	6-13
1176	1-20, 2-22, 5-17	4586	1-4	42661	1-4, 1-24, 2-24, 3-26, 3-37, 3-38, 3-57	73705	2-14
1178	4-6	4702	3-88	42823	1-4, 1-11, 2-9, 3-19, 3-20, 3-58, 4-7	73752	5-36
1181	2-21	4703	5-39	42827	3-39	73844	1-12
1193	2-14, 3-11		5-21	43954	5-3, 5-4, 5-15, 5-29, 6-26	73894	1-27
1196	2-2		1-10	44048	6-2, 6-5, 6-16, 6-19, 6-27, 6-29	74011	5-15
1210	3-28		3-46, 4-5, 4-6	45027	3-28	74272	3-24
1214	3-58		5-9, 5-26, 5-28, 6-5	45104	1-20, 1-22, 3-95	74283	3-33
1222	5-35, 6-7, 6-8, 6-25	4707	2-21	45815	2-14, 3-90, 5-29, 5-34, 5-35, 5-37, 5-38, 6-24	74291	1-25
1248	2-21	4708	4-4, 4-7	49420	1-10, 2-3, 2-6, 2-15, 2-20, 3-41	74479	5-3, 5-25
1257	5-15	4809	1-23	49514	5-22, 6-2, 6-27	74536	3-8
1263	5-34, 5-41	4812	4-3, 4-4, 4-7, 5-2, 5-11, 5-14, 6-15, 6-25	49644	5-27, 5-30	74546	5-2, 5-14
1264	5-11, 6-15	4814	5-40	49653	2-3	74547	3-22
1268	3-76	4851	5-26	55063	3-13	74553	3-17, 7-9
1272	2-2, 2-13, 2-23, 3-38	4851	3-22	55090	2-14	74554	2-14
1293	6-7, 6-9, 6-17, 6-25	5475	2-14	55219	(Sev.)	74567	5-3, 5-4, 5-14, 5-15
1297	5-44, 5-46, 5-48	5702	6-7, 6-8, 6-25	55318	5-49	74594	5-2
1301	1-10, 1-12, 1-13, 3-33, 6-5	5740	3-2, 3-94	55320	5-40	74613	1-25
2034	(Sev.)	6035	(Sev.)	55323	6-15	74614	6-7, 6-8
2191	3-5, 3-90, 6-5	6320	5-7	55669	1-2, 1-17, 2-2, 3-79	74615	6-11, 6-12, 6-24
2201	1-13	6342	3-8	61085	4-5, 4-6, 6-27	74691	6-24
2247	4-2, 4-8, 6-15	6345	5-26	62135	5-49	74694	2-14
2263	5-26		1-4	70071	1-24	74695	2-14
2322	2-14	6346	1-4, 1-5, 1-21, 1-22, 3-22, 3-26, 6-5	70072	3-81	74700	3-91
2382	2-6	6745	1-4, 3-59	70073	6-27	74701	3-6, 3-22, 7-15
2415	3-58, 6-20	6800	3-38	70314	5-20, 5-21	74712	3-8, 3-23, 5-2, 5-14
2422	3-35, 3-89	6807	6-7, 6-8, 6-25	70388	1-4, 2-10, 3-22, 3-66	74716	3-93
2438	1-2, 2-21, 5-3, 5-6, 5-7, 5-8, 5-14, 5-15, 5-23, 5-28, 5-29, 5-31, 5-39, 5-41, 5-42, 5-45 5-51, 5-53, 5-55, 6-13	6827	2-27			74722	1-16, 3-14
2449	2-20, 3-11, 3-91, 5-49	6970	3-2, 3-94			74727	3-93
2481	3-10, 3-22, 3-71, 5-2	7001	(Sev.)			74728	1-24, 3-81
2539	1-13	7002	5-7			74755	2-8, 3-24
2597	(Sev.)	7015	3-8			74785	3-22
2669	(Sev.)	7036	5-26			74798	3-10
2846	(Sev.)	7415	1-4			74805	1-27, 2-3, 2-8, 2-27
2864	5-42	7602	1-4			74807	2-21, 3-92
2920	5-18	7603	1-4, 1-5, 1-21, 1-22, 3-22, 3-26, 6-5			74821	6-7, 6-8
3226	5-23	7655	1-4, 3-59			74882	3-17, 6-5, 7-9
		7835	3-38			74889	5-39
		7959	6-13			74962	2-15
						74964	3-93
						74965	1-25

1149B

NUMERICAL INDEX (Continued)

Part Number	Page	Part Number	Page	Part Number	Page	Part Number	Page
75229	3-28, 3-77	82463	1-16, 3-8, 3-37, 3-38,	90814	5-9, 5-10, 5-28	95281	5-34, 5-36
75231	6-13		3-59, 3-84	90819	3-10, 3-22	95320	5-26
75607	2-21, 3-72	82474	(Sev.)	90951	1-20, 2-22, 3-71	95428	3-46, 3-47
75750	5-49, 5-56, 6-7, 6-8,	82505	5-8	90959	5-40	95499	1-20
	6-9, 6-10, 6-11, 6-17,	82516	6-7, 6-8, 6-25	91120	3-79	95827	3-28, 3-67, 7-7
	6-18, 6-24, 6-25, 7-8	82547	2-2A, 2-20, 3-81, 3-82,	91228	4-6	96258BK	5-21
76081	2-6		3-90, 3-93	91229	4-6	96260BK	6-5
76084	2-14	82548	2-2A, 2-20, 3-81, 3-90	91230	4-6	96264R	4-2, 4-8
76085	2-14	82832	5-33	91231	2-13, 4-6	96646	1-18, 2-15
76086	2-14	82860	1-21, 2-17, 3-72	91683	1-19, 1-26, 5-4, 5-13,	96696	6-25
76087	2-14	82870	6-9		5-20, 5-40, 6-2, 6-3,	96717	3-33
76099	1-3, 2-8, 2-21, 4-6,	82999	3-80		6-25, 6-27	97143	1-27
	5-2, 5-3, 5-14, 6-3,	83885	6-19	91684	1-19, 1-26	97256BK	4-6
	6-9, 6-11, 6-12	83913	2-20	91721	6-4, 6-14	97296	2-21
76236	5-33, 5-39	84575	3-8, 3-26, 3-27	91765	1-10	97393	5-25
76279	2-21, 5-45	84579	5-2, 5-14, 5-27, 5-30	91768	6-11, 6-12	97481	3-10
76299	1-7	84598	3-82	91837	4-3	97492	5-34, 5-36
76379	2-2A, 3-15, 3-17	84758	3-59, 3-84	91904	1-8	98462	4-3
76422	2-16, 2-25	84892	3-93	92136	5-46	98544	5-28
76461	3-26, 4-7	85407	3-56	92146	5-33, 5-34, 5-36, 5-39	98561	3-72
76474	3-95	85529	5-15	92260	4-3, 5-29, 6-6	98642	5-2, 5-7, 5-8, 5-14
76800	3-13	85559	5-5	92264	6-25	98712	2-14, 4-4
76832	6-22, 6-23	85609	5-34	92265	2-21	98718	5-40
76834	4-9	85816	3-26	92527	5-22, 6-2, 6-27	98726	3-81
76845	5-34	85935	3-91	92556	5-40	99174	6-22
76983	6-13	85957	1-7	92626	1-22, 2-18	99220	1-27
77051	1-25	85971	5-41	92668	1-10	99324	6-22
77063	1-16	86079	1-13, 3-72	92682	3-31	99358	6-22
77140	4-9	86304	2-12, 2-13, 2-23, 3-8	92687	5-5	100149	1-9, 1-18
77629	6-22	86329	5-33	92761	6-17, 6-25	100184	5-15
77902	5-56, 6-8, 6-10, 6-11,	86433	5-18	92857	6-4, 6-14	100337	3-60
	6-12, 6-18, 6-24, 7-8	86720	1-10	93073	6-14	100359	3-71
78103	5-2	86736	4-7	93082	1-18	100743	4-5
78287	5-3	86742	1-12, 1-18, 2-11	93107	2-21	100873	5-5
78301	5-35	86835	1-2, 2-2, 3-29, 3-35,	93108	5-3, 5-4, 5-8, 5-15	101386	1-12, 2-22, 3-5
78453	5-42		3-69, 3-74, 5-37	93117	1-24, 1-25, 2-24	101714	1-25
78469	5-6	86959	2-20, 3-82	93118	1-13, 2-2, 3-2, 3-94,	101796	1-5, 1-10, 3-8, 3-17,
78533	2-11, 3-33	86968	5-36		4-7, 5-17		3-28, 3-41
78766	5-29	87334	4-2, 4-8	93130	5-33, 5-34, 5-39,	101833	5-35
78904	6-22	87398	2-24	93191	5-39	102052	6-24
78905	6-22	87401	1-25, 3-59, 3-84	93356	2-21, 3-10, 3-11, 3-19,	102057	1-2, 1-17, 2-2
79012	6-16, 6-19, 6-29	88456	5-28, 5-31		3-22, 3-29, 3-41, 3-59	102092	5-49
79152	5-46	88891	2-20	93507	2-2A, 3-46	102180	5-9, 5-28
79513	6-13	89096	3-20, 3-26	93582	3-57, 3-79	102329	1-25
79523	5-52	89305	5-26	93634	2-14	102330	1-25
79967	6-16, 6-19	89515	5-14	93638	2-14	102617	5-2
80334	3-82, 3-90	89548	6-7, 6-8, 6-25	93639	2-14	102620	5-3
80342	3-47, 3-83, 5-3	89782	5-41	93644	2-14	102672	3-90
80444	5-49	89897	1-24, 3-28	93545	2-14	102673	3-90
80481	5-7	89969	5-20, 5-21, 6-3, 6-11,	93647	2-14	102751	5-15
80581	1-6, 3-8, 3-14		6-12, 6-15	93648	2-14	103092	5-2
80708	3-63, 3-66, 3-80	90096	5-13, 6-25	93649	2-14	103120	5-14
80721	6-15	90239	6-24	93705	2-14	103355	5-33
80755	3-81, 3-90	90260	1-10	93729	3-41	103612	5-18
80833	3-90	90361	(Sev.)	93758	1-12, 1-21, 1-22, 2-17,	103815	3-59
80848	3-13, 3-14	90432	3-15, 3-16, 3-17, 3-18		2-18, 3-8, 3-22, 3-64,	103863	3-48, 7-16
80854	5-20, 5-21, 5-26, 6-3,	90490	3-8		7-11	104124	5-55
	6-5, 7-8	90504	3-26	93783	6-24	104701	5-10
80945	2-27	90517	3-49, 3-57, 3-60, 3-79,	93879	3-8	104710	1-8, 2-7
81596	6-24, 2-27		3-88, 3-96, 7-7, 7-9,	93984	2-24, 5-40	104751	1-27
81726	2-20		7-10, 7-12, 7-13, 7-17	93985	5-40	104807	1-4, 1-25, 3-79, 4-7
81731	1-22, 2-18, 3-28, 3-69,	90560	4-7	94072	2-3	104827	1-26, 2-3
	3-77	90573	1-13, 2-24	94316	3-80	104898	5-39
81774	2-4	90599	1-25, 3-41, 5-8	94317	3-80	104991	2-24
81775	6-7	90679	1-10, 1-11, 3-8, 3-9,	94660	5-22	105028	3-29
81778	3-35		3-32, 7-13	94665	1-25	105551	1-27
81824	6-11	90707	6-24	94674	3-41	105567	5-39
81835	5-42	90714	1-27	94693	3-49, 3-57, 3-60, 3-79,	105650	5-44
81836	6-4, 6-14, 6-25	90789	(Sev.)		7-7, 7-9, 7-10	106047	1-2, 5-23
82392	4-7	90791	1-10, 1-13, 1-27, 2-12,	95005	5-56, 6-24	106200	6-11, 6-12
82442	3-8		2-13, 2-23, 3-17, 3-18	95030	3-56	106281	3-66

1149B

NUMERICAL INDEX (Continued)

Part Number	Page	Part Number	Page	Part Number	Page	Part Number	Page
107116	3-3, 3-68, 3-74, 3-76, 5-3, 5-15, 6-4	116959	2-21	122211	4-2, 4-3, 4-8	137602	6-29
107393	5-33, 5-53, 5-56, 6-2	117366	1-19	122220	4-2, 4-3, 4-8	133191	6-7, 6-8, 6-25
107398	4-6, 4-9, 5-24, 6-2, 6-3, 6-19, 6-20	117416	2-8	122221	4-3	138225	5-35, 5-56
107427	6-11, 6-12	117535	2-14, 5-42	122229	4-2, 4-8	138506	6-23
108007	1-25	117608	1-9, 1-14, 1-24, 2-4	122233	4-3	138535	6-23
108102	2-5	117878	5-21	122245	4-2, 4-8	138548	6-23
108103	2-21, 5-42	118118	5-3	122249	4-2, 4-8	139012	1-24
108199	3-22, 3-29, 3-41, 3-72	118119	5-3	122251	4-2, 4-8	139075	6-23
108335	5-6, 5-7, 5-8, 5-23, 5-28, 5-31	118169	6-25	122252	4-2, 4-8	139158	5-56
108370	2-10	118516	6-25	122253	4-3	139555	1-9, 1-18, 3-28
108891	1-21	118617	6-25	123769	4-2, 4-8	139752	2-7
108949	1-25	118720	6-25	124177	2-21, 3-34	139754	2-16
108959	6-25	118726	6-29	124244	2-2A	139777	6-9, 6-10
110191	1-27	118759	5-2, 5-56	124566	6-23	142294	6-23
110434	(Sev.)	119121	6-17	124681	3-6, 3-65, 7-15	142379	2-27
110435	1-4, 1-13, 3-31, 3-66, 4-7, 5-3, 5-4, 5-15, 6-5, 6-26	119389	5-28	124955	5-36	142679	6-23
110436	1-20, 3-28, 3-67, 7-7	119401	5-40	124999	1-24, 5-17, 5-52	142683	6-23
110437	2-6, 3-22, 3-59, 5-3	119418	3-58	125002	5-40, 5-43	142686	6-23
110475	1-27, 4-7	119467	1-24, 1-25, 3-58, 5-17	125011	(Sev.)	143291	6-23
110576	1-27	119535	2-14	125014	5-45	143292	6-23
110743	(Sev.)	119638**	5-2	125015	(Sev.)	143293	6-23
110747	3-6	119641**	5-2	125108	5-33, 5-39, 5-40, 6-19	143295	6-23
110872	3-26	119647	1-10	125110	5-9	143297	6-23
110879	3-84	119648	(Sev.)	125112	2-2A, 6-13	143299	6-23
111003	5-29	119649	(Sev.)	125122	1-24, 6-13	143300	6-23
111017	(Sev.)	119650	3-87, 5-41	125126	1-13, 2-12, 2-13, 2-23, 3-83	143301	6-23
111062	4-3	119651	(Sev.)	125129	6-24	143302	6-23
111342	1-10, 3-84	119652	(Sev.)	125139	5-10	143303	6-23
111343	1-8, 2-7	119653	(Sev.)	125143	4-3	143304	6-23
111345	5-25, 5-41	119654	2-6	125164	6-15	143306	6-23
111346	5-25, 5-41	119655	5-26	125170	6-16, 6-19, 6-29	143307	6-23
111347	5-25	119670	5-44	125181	1-2, 1-16, 1-17, 1-18, 2-15, 7-14	143308	6-23
111355	3-8	119935	3-5, 3-90	125185	5-36	143309	6-23
111409	1-25, 5-6	120142	6-25	125218	5-3, 5-4, 5-15, 5-41, 5-56	143310	6-23
111516	2-14, 3-95, 5-34, 5-35, 5-37, 5-38, 6-24	120175	2-5	125224	5-23, 5-45	143311	6-23
111767	1-10, 2-11, 7-13	120195	6-6	125231	2-21, 5-2, 5-3, 5-4, 5-12, 5-13, 5-14, 5-15, 5-34, 5-35, 5-38, 6-24	143312	6-23
111776	5-30, 6-24	120208	6-19	125238	3-28	143313	6-23
111777	5-30, 6-24	120824	1-11, 2-9	125241	1-18	143314	6-23
111970	6-9, 6-10	120870	2-10	125268	1-12, 3-77	143315	6-23
111971	6-9, 6-10	121018	1-27	125286	3-77, 3-89, 3-92	143316	6-23
112127	2-2A	121120	3-76	125306	6-13	143317	6-23
112128	2-2A	121125	2-20, 5-26, 6-5, 6-11, 6-12	125390	5-5, 6-19	143318	6-23
112509	3-93	121242	1-27, 2-15, 3-82, 5-13, 5-37	125802	3-14, 3-28, 3-48, 4-7, 5-39, 7-15	143319	6-23
112626	(Sev.)	121243	(Sev.)	126959	5-30	143320	6-23
112627	1-18, 3-17, 3-18, 3-58, 4-5, 4-6, 5-52, 6-20	121244	(Sev.)	128002	1-10, 3-17	143321	6-23
112629	3-84	121245	2-2, 2-22, 3-47, 5-4, 5-10, 5-12, 5-13, 5-20, 5-40, 6-5, 7-7, 7-9	128357	3-13, 5-2	143322	6-23
112630	1-7, 2-2, 5-42	121246	5-29, 5-37, 6-25, 6-27	128874	4-2, 4-8	143323	6-23
112633	3-41	121247	1-3, 3-47, 5-10, 5-35, 6-3, 7-8	129219	5-39	143324	6-23
112634	3-37, 3-38	121248	3-74, 5-32, 6-2	129382	5-27	143325	6-23
112695	1-23	121249	3-76, 5-35, 6-2	129488	6-24	143326	6-23
112889	3-59	121473	2-19, 2-25	129502	5-13	143327	6-23
113099	5-37	121533	5-40	129514	5-40	144600	5-44
113980	1-24, 1-25	121539	4-6, 4-9	129852	6-25	144696	5-43
114125	2-21	121575	2-2, 2-21, 3-90, 5-42, 5-44	129854	6-25	144697	5-43
114214	3-5	121605	3-66, 5-41	129854	6-25	144871	2-2A
114478	5-40, 6-25	122057	1-16, 1-25	129855	6-25	144969	5-43
114589	5-3, 5-4, 5-15	122149	3-48	129919	5-37, 6-3, 7-8	144971	5-43
114654	6-29	122200	4-3	130499	2-21	144972	5-43
115122	2-8, 2-11, 3-15	122201	4-3, 4-8	130683	2-19	144974	5-43
115358	6-27	122202	4-3	130696	3-83	144979	5-56, 6-27
115594	5-43	122204	4-3	131045	6-13	144989	5-49
116082	3-17	122205	4-3	131099	2-12	145003	5-56, 6-27
116783	5-37, 5-38, 5-56, 6-2, 6-3, 6-21, 6-24, 6-27	122205	4-3	131228	5-56	145007	6-27
		122208	4-3	135716	3-22, 3-57, 3-59, 3-79	145010	5-46
		122210	4-3	136859	5-30	145013	6-27
				136884	5-21	145014	6-27
						145016	6-27
						145017	5-47
						145023	5-46, 5-48
						145024	5-40, 5-46
						145026	6-27
						145047	5-24

I 149B

NUMERICAL INDEX (Continued)

Part Number	Page	Part Number	Page	Part Number	Page	Part Number	Page
145062	6-28	145467**	5-41	150052	3-21	150293	3-39
145063	6-28	145468	5-41	150053	3-41	150296	3-48
145064	6-28	145469	5-42	150054	3-41	150298	3-48
145065	5-24	145470	5-42	150055	3-11,3-31	150301	3-39
145067	6-28	145471	5-42	150056	3-20	150302	3-39
145073	5-46	145476	5-42	150059	3-41	150304	3-39
145074	5-46	145481	5-43	150061	3-41	150310	3-38
145075	5-48	145487	5-42	150064	3-41	150311	3-37
145076	5-48	145488	5-42	150065	3-41	150318	3-14
145077	5-2	145489	5-42	150068	3-41	150323	5-43,5-56,6-19
145094	5-46	145490	5-41	150075	3-18	150327	3-37,3-38
145104	6-27	145491	5-41	150077	3-43	150335	3-38
145207	5-46,5-48	145492	5-54	150078	3-42	150336	3-28,3-37,3-38
145208	5-46	145493	5-39	150079	3-42	150341	3-2
145210	6-27	145713	5-39	150080	3-17,3-18	150342	3-14
145214	5-44	145714	5-39	150089	1-4,1-27,2-21,2-25, 3-28,3-35,3-82	150343	3-38
145216	5-44	145721	5-44			150344	3-37
145217	5-44	145769	5-39	150091	3-19	150348	3-22
145219	5-44	145770	5-39	150096	3-6,7-15	150349	3-22
145220	5-44	145771	5-39	150097	3-7	150350	3-22
145231	5-40	145772	5-39	150098	3-7	150351	3-2
145236	5-40	145773	5-39	150099	3-7	150352	3-22
145237	5-40	145774	5-39	150100		150353	3-2
145238	5-40	145775	5-39	through		150354	3-23
145239	5-40	146163	5-41	150162	3-43	150355	3-22,3-23
145241	5-40	146164	5-41	150175	3-29	150356	3-22,3-23
145244	5-24	146165	5-41	150184	3-28	150358	3-22
145246	6-27	146166	5-41	150193	3-28	150361	3-22,3-80,5-21
145251	5-40,5-53	146167	5-41	150194	3-28	150363	3-15
145252	5-46	146168	5-41	150196	3-28	150364	3-19
145253	5-44	146169	5-41	150197	3-24	150365	3-15
145254	5-2	146170	5-41	150201	3-29	150366	3-15
145256	5-24,5-40	146171	5-41	150202	3-28	150367	3-17
145264	5-40	146173	5-41	150203	3-28	150369	3-15
145265	5-40	146179	5-41	150204	3-28	150370	3-17
145266	5-40	146185	5-41	150206	3-24	150371	3-48
145277	5-17	146186	5-41	150208	3-29	150377	3-8
145278	5-17	146187	5-41	150214	3-8	150380	4-17
145281	5-46,5-48	146188	5-41	150215	3-29	150382	3-15,3-17
145282	6-28	146189	5-41	150218	3-29	150383	3-15
145283	6-28	146190	5-41	150219	3-26	150384	2-17
145284	6-28	146291	Cable 5-55	150224	3-26	150386	3-15
145301	3-49	146332	5-41	150225	3-24	150387	3-17
145307	2-2A	150000	3-19,3-20	150228	3-28	150390	3-15,3-16,3-17,3-18
145317	5-42	150001	3-20	150229	3-28	150391	3-21
145318	5-42	150004	3-20	150230	3-41	150392	3-8
145365	2-27	150013	1-11,2-9,3-19,3-20	150232	3-29	150395	3-15,3-17
145368	2-2A	150014	3-19,3-21	150233	3-28	150396	3-15
145373	3-83	150016	3-20	150234	3-28	150397	3-17
145392	2-27	150026	1-11,2-9,3-19,3-20	150235	3-28	150398	3-10
145393	2-27	150027	3-19,3-21	150237	3-26	150399	3-8
145430	5-42	150028	1-11	150241	1-11,2-9,3-19,3-20	150401	3-15
145435**	5-39	150029	1-11,2-9,3-19,3-20	150244	3-19	150410	3-15
145445	5-39	150030	3-41	150245	3-29	150411	2-24,3-17,5-26,5-29
145446**	5-39	150032	3-21	150247	3-29	150412	3-15
145448**	5-39	150033	3-19	150251	3-24	150413	3-17
145450	5-46	150034	3-21	150255	3-26	150414	3-10
145451	5-39	150035	3-19	150263	3-29	150419	3-10
145452**	5-39	150038	3-41	150265	3-6	150420	3-17
145453**	5-39	150039	3-41	150266	3-6	150423	3-10
145454**	5-39	150040	(Sev.)	150267	3-6	150424	3-15,3-16
145455**	5-41	150043	1-11,2-9,3-19,3-20	150269	3-6,7-17	150425	3-15,3-17
145456**	5-41	150044	1-11,2-9,3-19,3-20	150270	3-6,7-15	150428	3-15
145457**	5-41	150045	3-19,3-20	150271	3-6	150429	3-15,3-17
145458**	5-39	150046	3-19	150274	3-6	150431	3-22
145459	5-39	150047	3-20	150276	3-6,7-15	150434	3-27
145460	5-41	150048	3-33	150285	3-39,3-40	150436	3-6,3-13,3-28,7-15
145464	5-41	150049	3-21	150288	3-39	150438	3-28,3-67,7-7
145465	5-41	150050	3-20	150289	3-39	150439	3-19
145466	5-39,5-41	150051	3-20	150291	3-48		



1149B

NUMERICAL INDEX (Continued)

Part Number	Page	Part Number	Page	Part Number	Page	Part Number	Page
150440	3-19	150701	4-3	150873	4-3	151038	1-10
150441	3-19	150705	3-25	150877	4-4	151039	1-10
150444	3-22	150709	3-26	150879	4-4	151041	1-10
150447	3-31	150710	3-26,5-13	150880	4-3	151043	1-4
150450	3-31	150711	3-83	150881	4-3	151045	1-8,2-4
150451	3-32	150712	3-24	150882	4-3	151051	1-12
150452	3-31	150714	3-14,7-15	150884	4-3	151052	1-13
150453	3-31	150715	3-14	150885	4-3	151053	1-13
150471	3-31	150718	3-14	150886	4-3	151054	1-10
150475	3-31	150719	3-14	150889	3-23	151054	1-10
150479	3-33	150720	3-14	150891	3-17	151055	1-13
150481	3-31,3-65	150721	3-26	150894	3-8,7-11	151056	1-12
150482	3-31	150722	3-26	150895	3-22	151057	1-10
150507	3-31	150726	3-26,3-27	150900	3-2,7-16	151059	1-12,1-18,2-15
150525	3-32	150727	3-26,3-27	150902	3-4	151060	1-17
150531	3-27	150728	3-26	150903	3-10,7-16	151062	1-13
150535	3-39	150731	3-28	150904	3-10,7-16	151063	1-11
150536	2-27,3-28	150732	3-28	150907	3-10,7-16	151064	1-11
150537	3-28,3-29	150733	3-28	150910	3-56	151065	1-13
150538	3-28	150738	3-28	150911	3-14	151066	1-10
150543	3-46	150740	3-30	150912	3-14	151067	1-10
150544	3-46,3-47	150745	3-28	150913	3-9	151068	1-11
150545	3-3	150748	3-29	150915	3-9	151073	1-27,2-20,3-14,3-70, 3-72,3-86
150546	3-2	150750	3-26	150919	3-8	151075	1-17
150547	3-46,3-47	150751	3-26	150923	2-2A,2-10,2-11,3-22 3-29,3-41	151076	1-8
150549	3-19	150752	3-29	150926	3-26	151080	1-8,2-7
150553	3-48	150753	3-29	150927	3-26	151081	1-8
150554	3-26	150754	3-29	150929	3-26	151082	1-5
150557	3-9,3-68	150755	3-29	150930	3-8	151084	through
150558	3-29	150757	3-29	150931	3-21	151092	1-4
150559	3-29	150758	3-29	150932	1-22,2-18,3-37,3-38	151096	1-10
150561	3-8,3-9	150770	3-28	150936	3-56	151097	1-13
150563	3-31	150771	3-28	150937	3-38	151098	1-12
150569	3-4	150776	3-29	150953	3-26,3-27	151099	1-10
150571	3-48	150777	3-29	150961	3-2	151100	1-17
150572	3-48	150781	3-8,3-9	150963	3-48	151101	1-4
150573	3-48	150796	3-24	150964	5-31	151102	1-5
150576	3-48	150798	3-24	150966	1-2,2-2,5-12,5-13, 5-20,5-37,5-38,5-41, 5-56	151103	3-33
150579	3-4	150800	3-26	150969	3-2,3-13,7-16	151104	1-4
150585	3-14	150803	3-6,7-15	150970	3-19	151105	1-8
150586	3-14	150804	3-6,7-15	150971	3-52	151106	1-10
150587	3-48	150805	3-26	150973	3-43,3-57,3-60,3-88, 7-9	151112	1-7
150588	3-48	150806	3-26	150975	3-28	151113	1-2,1-3,2-2,5-37, 5-41
150598	3-29	150807	3-26	150976	4-2,4-5	151115	1-7
150642	3-14	150809	3-14	150978	3-31,3-80	151116	1-2,1-3
150646	3-13,3-14	150811	3-17	150980	4-5	151118	1-2,1-3,2-2,5-37 5-42
150647	3-14	150815	3-6,7-15	150987	3-28	151126	1-6,2-3
150648	3-14	150816	3-6,7-15	150990	2-11,3-10,3-11,3-31, 3-32	151127	1-6
150649	3-14	150821	3-37	150991	2-6,2-8,3-12	151130	through
150650	3-14	150824	3-17	150992	3-6,6-19,7-16	151135	1-17
150651	3-14	150826	3-6,7-15	150995	4-5	151140	1-14
150652	3-14	150827	3-24	150997	4-4	151145	1-12
150654	3-2	150830	3-19,3-21	150998	3-14	151146	1-2,2-2,5-37,5-42
150655	3-14	150831	3-19,3-21	151008	1-4	151151	1-11
150658	3-14	150833	3-14,7-15	151013	1-8	151152	(Sev.)
150665	3-21	150838	3-24	151014	1-8	151154	1-11
150666	3-14,7-15	150840	3-6,7-16	151016	1-10	151157	1-13
150668	3-28	150841	3-19,3-21	151018	1-10	151158	1-13
150669	3-28	150843	3-24	151023	1-4	151159	1-7,5-42
150670	3-28	150849	4-4,4-7	151025	1-12	151161	1-13
150672	3-28	150850	4-4,4-7	151026	1-12	151167	1-4
150673	3-28	150856	4-4,4-7	151030	1-4	151169	1-13
150677	3-28	150857	4-4,4-7	151032	1-4	151170	1-13
150678	3-28	150858	4-4,4-7	151036	1-4,1-8,2-11	151171	1-13,2-12,2-13,2-17, 2-23
150685	3-6,7-15	150859	4-4,4-7	151037	1-12		
150687	3-33	150865	4-4				
150689	3-46	150866	4-4				
150691	3-26,3-27	150868	4-4,4-7				
150692	3-26,3-27	150869	4-4				
150694	3-28	150872	4-4				

1149B

NUMERICAL INDEX (Continued)

Part Number	Page	Part Number	Page	Part Number	Page	Part Number	Page
151173	1-13	151336	3-33	151505	5-2,5-14	151589	5-3,5-4,5-15
151176	1-13	151338	1-8,1-9	151506	5-2,5-14	151590	5-3
151177	1-13	151341	1-2,1-17,7-10	151507	5-2,5-14	151594	5-18
151179	1-13	151342	1-2,1-17,7-10	151508	5-2,5-14	151595	5-15
151180	1-13,2-12,2-13,2-17, 2-23	151345	(Sev.)	151509	5-2,5-14	151596	5-15
151182	1-13,2-12,2-13,2-17, 2-23,3-29	151348	1-2,1-3	151511	5-2,5-4,5-15,5-28, 5-31,5-41	151597**	5-14
151183	1-13	151350	1-4	151512	5-2,5-14	151598	5-2
151184	1-13	151352	1-7,2-2	151513	5-2,5-14	151599	5-2,5-14
151185	1-13	151353	1-8	151514	5-2,5-14	151602	3-15,3-17
151188	1-13	151354	1-8,1-25,3-2,3-63, 3-94	151515	5-2,5-14	151603	3-17,3-35
151189	1-10	151355	1-4	151516	5-15	151604	3-15,3-17
151190	1-12	151358	1-13	151519	5-2,5-14	151606	3-11,3-28
151191	1-4	151359	1-13	151521	5-2,5-4,5-15	151607	3-36
151193	1-4	151365	1-2	151522	5-2,5-4,5-15	151610	2-29,3-19,3-41,3-69
151201	1-11	151367	1-4	151523	5-2,5-14	151611	3-41
151205	1-12	151369	1-2	151524	5-2,5-4,5-15	151612	3-41
151207	1-10	151376	2-4	151525	5-3,5-4,5-15	151618	(Sev.)
151211	1-10	151389	2-4	151526	5-2	151619	3-24
151213	1-10	151390	2-4	151527**	5-2,5-14	151620	4-2,4-3,4-8
151215	1-10	151391	1-8,2-4	151528	5-15	151621	4-2,4-3,4-8
151216	1-10	151395	1-12	151529	5-3	151622	4-2,4-3,4-8
151217	1-10	151397	1-13,2-24	151530**	5-2,5-14	151625	3-29
151218	1-16	151398	1-13	151531	5-3	151626	(Sev.)
151219	1-6	151399	1-2	151532**	5-14	151627	3-10
151222	1-12,3-11,3-31,3-47	151400	6-5,7-9	151534	5-3,5-14	151629	2-29,3-13,3-22,3-31, 3-71,3-83,5-56
151223	1-8,2-4,3-17,3-18	151401	6-5	151536	5-2,5-14	151630	(Sev.)
151224	1-8,2-2A,2-4	151402	6-5	151537	5-15	151631	(Sev.)
151225	1-10	151403	6-5	151538	5-2,5-14	151632	(Sev.)
151226	1-8,1-9	151406	6-5	151540	5-3,5-4,5-9,5-10, 5-13,5-15,5-16,5-20, 5-26,5-27,5-28,5-30, 5-31,5-49,5-56	151633	3-15,3-20
151227	1-8	151407	6-5	151541	5-14	151637	(Sev.)
151228	1-6,2-3	151408	6-5	151542	5-2,5-14	151640	3-20
151229	5-52	151409	6-5	151544	5-3	151642	1-10,1-27,3-19,3-20, 3-57,3-73,3-79,3-91, 4-3
151234	1-20,2-22	151410	6-5	151545	5-2,5-14,5-25,5-28, 5-31,5-41,7-16	151644	3-15,3-17
151235	1-20,2-22	151411	5-27,5-30,6-2,6-3, 6-27,7-8	151547	5-15	151657	(Sev.)
151236	1-20,2-22	151412	2-2A,5-27,5-30,6-2, 6-3,6-27,7-8	151548	5-15	151658	(Sev.)
151237	1-20,2-22	151413	1-27	151549	5-3,5-4,5-15,5-26, 5-28,5-31,5-34	151659	1-8,1-9,2-4,2-21, 3-38,4-4,4-7,5-10, 5-40,6-15
151239	1-20	151414	6-5	151551	5-3	151660	2-14,3-62,3-91,6-25
151240	1-20,2-22	151415	1-2,2-2,5-12,5-13, 5-20,5-37,5-38,5-41, 5-56	151553	5-2	151661	3-28,4-3,4-4,4-5
151241	1-20,2-22	151416	1-2,2-2,2-2A,5-12, 5-13,5-20,5-27,5-30, 5-37,5-38,5-40,5-41, 5-56,6-2,6-3,6-27, 7-8	151555	5-3,5-4,5-15	151667	3-32
151243	1-20	151417	6-5	151556	5-2,5-14	151668	3-31,3-32
151244	1-20,2-22	151418	6-2,6-3	151557	5-25	151669	3-32
151245	1-6,1-20,2-22	151419	6-2,6-3	151558	5-2,5-9,5-14,5-25, 5-27,5-30	151670	3-32
151246	1-6,1-20,2-22	151420	6-2	151559	5-2,5-14	151676	3-32
151286	1-14	151421	6-2	151560	5-3,5-4,5-15	151678	1-2,2-2
151287	1-14	151422	6-2,6-3,6-27	151562	5-3	151683	3-44,7-10
151288	1-14	151423	6-2	151564	5-3,5-4,5-15,5-29, 6-26	151685	(Sev.)
151289	1-14	151427	(Sev.)	151565	5-3,5-4,5-15,5-29, 6-26	151686	2-12,2-13,2-16,2-23, 3-6,3-28,3-35,3-81, 4-2,4-7,5-3,5-28, 7-10,7-16
151290	1-14,1-16,2-15	151435	5-2,5-56	151566	5-3,5-4,5-15,5-29, 6-26	151687	2-25,3-48,3-83,5-33 5-39
151291	through	151436	5-56	151567	5-3,5-4,5-15,5-29, 6-26	151688	1-4,1-25,2-16,3-19, 3-35,3-47,3-71,3-80
151300	1-14	151437	6-2,6-4,6-27	151569	5-3,5-4,5-15	151689	3-6,3-20,3-47,3-50, 3-51,3-81
151301	1-15	151441	6-4	151571	5-3,5-4,5-15	151690	3-19
151302	through	151442	2-4,2-9,2-14,2-27, 3-2,3-15,3-94,5-2, 5-32	151572	5-3,5-4,5-15,5-36	151691	3-26,5-12,5-40
151306	1-14	151443	3-41	151573**	5-14	151692	(Sev.)
151307	1-15	151444	1-25	151574	1-19,5-3,5-4,5-7, 5-15,5-29	151693	1-3,2-21,3-19,3-38, 3-91,4-7,5-29,5-56
151308	through	151446	7-10	151575	5-15	151694	2-2
151322	1-14	151453	4-3	151576	5-15	151695	3-41
151325	1-8	151455	4-3	151577	5-3,5-4,5-15,5-29	151698	3-26,3-27
151326	1-8,1-9	151500**	5-2	151578	5-2,5-14	151700	3-29
151329	1-2,1-17,1-18,1-20, 2-15,2-22,3-58,3-63, 7-10	151503**	5-2,5-14	151579	5-3,5-4,5-14,5-29, 6-26	151701	3-33
151333	1-11	151504	5-2,5-14	151588	5-9		

1149B

NUMERICAL INDEX (Continued)

Part Number	Page	Part Number	Page	Part Number	Page	Part Number	Page
151702	3-46	151856		152028	6-11, 6-12	152337	3-64, 7-12
151703	3-6, 7-16	through		152030	6-11	152338	1-20
151709	3-41	151859	1-7	152034	4-6	152340	3-65
151712	1-6, 2-3	151861		152035	4-6	152342	1-19
151713	3-9, 3-87	through		152037	4-6	152343	1-17
151714	3-33	151863	1-7	152039	4-6	152344	1-18
151715	2-24, 3-35	151867	1-9	152040	4-6	152345	3-66
151718	5-3	151879	1-20, 2-22	152044	4-5	152348	3-67
151721	3-2, 3-10, 3-31, 3-83, 3-94, 5-55, 7-16	151880	(Sev.)	152045	1-2, 2-2	152349**	5-5
151722	(Sev.)	151884	1-20	152046	4-6	152350	3-68
151723	1-6, 2-2A, 2-14, 3-28, 3-92, 5-2, 5-3, 5-13, 5-14, 5-17, 5-34, 5-37, 5-43	151885	1-20, 2-22	152051	2-4	152351	6-11, 6-12
151724	1-6, 2-3, 5-12, 5-21, 5-35, 5-56	151886	1-20, 2-22	152056	5-2	152357	3-49, 7-7, 7-13
151725	1-6, 2-3, 5-35	151887	1-10, 1-16	152058	4-6	152359	3-57
151726	5-2	151889	1-4	152059	4-6	152360	3-57
151727**	5-2, 5-14	151893		152067	4-6	152400	3-33
151728	1-11, 2-9, 3-19, 3-20	through		152078	4-5	152401	3-33
151731	1-13, 2-2, 2-13, 3-14	151898	1-6	152089	3-49, 3-96, 7-7, 7-12, 7-13	152402	3-33
151732	2-19, 2-21, 3-19, 3-69, 3-74	151899	1-12	152108	6-7	152403	3-33
151733	2-20, 3-90	151901		152109	6-7, 6-8, 6-24	152404	3-33
151734	3-17	151910	1-14	152110	6-7, 6-8, 6-18	152405	3-33
151736	3-19, 3-21	151913	6-6	152121	3-49, 3-96, 7-12	152406	3-33
151737	1-11, 2-9, 2-24, 2-27, 3-19, 3-20, 3-79, 3-81	151914	6-6	152122	1-7	152407	3-33
151738	3-42	151916	6-6	152123	6-7	152410	3-33
151739	1-14, 3-47, 7-10, 7-12	151920	4-2	152124	6-7, 6-8, 6-25	152411	3-33
151794	3-19, 3-21	151922	4-2, 4-8	152127	3-46, 7-10	152412	3-33
151795	4-2, 4-8	151923	4-2, 4-8	152129	3-41	152413	3-36
151797	3-52, 7-17	151924	4-2	152130		152415	3-35
151801	6-3	151925	4-2, 4-8	through		152420	3-35
151808	6-2	151926	4-2, 4-8	152139	1-15	152421	3-35
151813	6-2	151927	4-2, 4-8	152140	3-8	152422	3-36
151814	6-2	151930	3-44	152147	3-17	152423	3-35
151818	6-4, 6-7, 7-8, 6-25	151931	3-44	152250	1-4	152424	3-35
151819	3-35, 5-2, 6-4, 6-5, 6-8, 6-10, 6-13, 6-15, 6-17, 6-19, 6-25, 7-8	151934	1-14	152254	3-15, 3-17, 3-30	152425	3-35
151820	1-13, 2-12, 2-13, 2-23	151937	3-44	152255	3-39	152426	3-33, 5-5, 5-56
151822	6-7, 7-8	151938	3-44	152256	3-39	152427	3-33
151825	6-6	151941		152257	3-39	152429	3-33
151826	6-7	through		152296	1-4	152432	3-33
151827	5-27, 5-30, 5-40, 6-3, 7-8	151953	3-43	152297	4-2, 4-8	152434	3-34
151830	1-4	151955	5-3, 5-4, 5-15	152298	3-49, 3-96, 7-7, 7-12, 7-13	152435	3-34
151832	1-13	151956	5-2, 5-14	152299	3-49, 7-7	152436	3-33
151833	1-8	151982	5-4, 5-12, 5-13, 5-16, 5-27, 5-30, 5-31, 5-37, 5-39, 5-41	152300	5-7	152437	3-34
151834	1-8	151983	5-4, 5-15, 5-26, 5-27, 5-30	152302	3-5, 7-11	152438	3-33
151835	1-10	151988	5-22	152303	3-58, 7-11	152439	3-34
151837	1-10	151989	5-22	152304	3-59, 3-60	152440	3-34
151840	1-4	151995	6-4	152307	7-7	152441	2-21, 3-33, 3-83, 7-11 7-14
151841	1-8	151996	6-4	152309	5-4, 7-7	152445	3-33
151842	1-8	151999	6-6	152310	5-4, 5-15	152447	3-20
151843	1-8, 2-7	152000	1-2, 1-3	152312	3-61	152450	3-20
151844	1-8	152001		152313	5-26	152456	3-31
151845	1-4	through		152314	5-26	152457	3-31
151846	1-16	152006	1-14, 7-10, 7-11	152315	3-62	152459	3-35, 3-36
151848	1-8	152007	1-15	152316	7-7	152459	4-5, 4-6
151849	1-5	152008		152317	3-63	152460	1-2, 5-37
151851	1-5	through		152318	1-8, 2-15	152461	3-35
151852	1-5	152016	1-14	152319	5-11, 7-7	152462	1-2, 2-2, 3-35, 3-68, 3-74, 5-37, 5-41, 5-55
151853	1-5, 1-21, 1-22	152017		152321	7-7	152463	1-2, 2-2, 3-35, 3-74, 3-57, 5-41, 5-55
151853	1-22	152020	1-15, 7-10	152322	7-7	152464	1-2, 2-2, 3-35, 3-74, 5-37, 5-41, 5-55
151854	1-5	152021	6-11, 7-8	152324	7-8	152465	1-23, 5-24, 5-56, 6-20, 6-22, 6-28
151855	1-5	152022	6-11, 6-12	152326	7-8	152465	2-76, 5-10, 5-24, 5-29, 5-35, 5-57, 6-20, 6-28
		152023	6-11, 6-12	152328	7-8	152467	1-2, 2-2, 2-12, 2-13, 2-23, 3-35, 3-68, 5-41, 5-55, 6-22
		152024	6-11, 6-12	152329	7-9		
		152025	6-11, 6-12	152330	6-4		
		152026	6-11	152331	6-14		
		152027	6-11, 6-12	152332	6-13, 6-14		
				153333	1-16		
				152334	1-18		

1149B

NUMERICAL INDEX (Continued)

Part Number	Page	Part Number	Page	Part Number	Page	Part Number	Page
152468	3-35	152595	3-26	152754	2-2A,6-4	152927	3-55,3-79
152493	1-10	152596	3-28	152755	5-40,6-2	152938	3-57,3-79
152495	4-4,4-7	152597	3-28	152757	6-4	152942	5-26
152501	3-17,3-18	152598	3-29	152760	6-2,6-3,6-27	152943	3-57,3-79
152502	3-17,3-18,7-9	152599	3-29	152761	6-2,6-3	152950	6-6
152503	3-17	152623	6-8,6-18,7-8	152763	6-9	152968	5-26
152505	3-25	152624	5-12,7-8	152764	1-17	152959	5-26
152507	3-26	152625	6-10,7-8	152765	1-17	152971	5-26
152508	3-26	152626	3-46	152766	1-17	152972	5-26
152509	3-26	152627	3-46	152767**	5-2,5-14	152973**	5-26
152510	3-26	152629	3-37	152768	5-3,5-4,5-15	152985	3-57
152511	3-26	152630	3-37,3-38	152797**	5-14	152988	6-26
152514	3-8	152633	3-38	152814	1-12	152993	5-26
152515	3-8	152634	3-28,3-67,7-7	152815	1-16	152994	6-3
152516	3-8	152635	3-31	152818	3-38	152995	6-26
152517	3-23	152636	3-31	152819	3-37	152996	6-26
152518	3-8	152637	3-31	152820	3-38	152997	6-20
152521	3-26	152638	3-31	152821	3-37	152998	6-3
152522	3-28	152639	3-31	152823	3-38	152999	6-26
152523	3-27,3-38	152640	3-31	152824	3-37	153017	5-23,5-41,5-56
152524	3-37,3-38	152641	3-49,3-57,3-79,3-88, 7-9,7-10,7-14	152826	3-37,3-38	153020	5-3,5-4,5-25,5-27, 5-30
152525	3-37,3-38			152827	3-38		
152526	3-37	152642	3-49,3-60,3-96,7-12	152828	3-37	153021	5-3,5-4,5-8,5-25, 5-27,5-30,5-51
152527	3-38	152643	3-46	152831	3-2,3-3,7-16		
152528	3-38	152644	3-38	152832	3-6,7-16	153022	5-3,5-4,5-8,5-25, 5-27,5-30,5-51
152529	3-37	152646	3-38	152834	3-37,3-38		
152536	3-29	152647	3-37	152839	1-4	153023	5-3,5-4,5-8,5-25, 5-27,5-30,5-51
152537	3-19	152648	3-37	152848	5-6,5-7,5-8,5-23, 5-51	153024	5-4
152538	3-28	152651	3-46,3-47	152849	6-5	153027	5-4
152539	3-6,7-16	152652	3-46,3-47	152871	3-14,7-16	153030	4-2,4-3,4-8
152541	3-16	152653	3-49,3-96,3-57,3-60, 3-79,3-88,7-7,7-9, 7-13,7-17	152873	through	153031	4-3
152542	3-18			152878	1-4	153032	5-2
152543	3-11	152654	3-48	152881	3-44	153033	5-2
152545	3-8	152655	3-48	152882	5-2,5-14	153034	5-2
152546	3-31	152656	3-48	152883	5-2,5-14	153035**	5-2
152547	3-46,3-47	152658	3-48	152884	5-2,5-14	153036	5-2
152548	3-39	152659	3-49	152885	5-2,5-14	153037	5-2
152549	3-40	152660	3-49,3-57,3-60,3-79, 3-88,3-96,7-7,7-9, 7-10,7-12,7-14	152887	3-19,3-20,3-21	153039	5-2
152550	3-15			152888	3-21	153040	6-5
152551	3-39			152889	3-47,7-11	153042	5-3,5-4,5-25
152552	3-39	152662	3-31	152890	3-28	153046	5-3
152553	3-39	152663	3-31	152891	3-33	153047	5-15
152554	3-39,3-40,7-7	152665	through	152893	2-7,3-8,3-15,3-32 3-33,3-57,3-64,3-85	153048	5-2
152555	3-11	152693	3-53,3-54,7-9,7-10, 7-11,7-12,7-13		6-19	153049	4-2,4-8
152559	3-43	152694	3-53,3-54,3-79	152894	1-12	153071	3-48
152560	3-42	152695	through	152896	3-52	153073	3-48
152563	3-8			152897	3-34	153074	3-48
152569	3-30			152899**	5-7	153076	3-71
152570	3-30	152704	3-54,3-54	152900	7-10	153077	3-71
152571	3-38	152708	3-9,3-68	152901**	5-8	153078	3-71
152572	3-39	152711	3-9	152902	5-9	153079	3-71
152573	3-20	152716	3-11	152904	1-14	153080	3-71
152574	3-39	152717	3-21	152905	1-14	153081	3-71
152575	3-39	152718	7-9	152906	1-14	153082	3-71
152576	3-39	152719	7-9	152910**	5-7	153083	3-71
152579	3-26	152720	7-9,7-10	152911	1-18	153084	3-48
152580	3-3	152721	3-39,3-40	152913	3-71	153099	5-8,5-51
152581	3-2	152723	3-6	152914	7-10	153100**	5-2
152582	3-38	152724	3-30	152915	3-69	153101	4-3
152583	3-31	152725	3-6	152916	1-22	153102	4-3
152584	3-31	152726	3-22	152917	3-86	153103	4-3,5-39
152585	3-31	152742	3-44	152918	1-21	153104	5-8
152586	3-28	152744	6-9,7-8	152919	7-10	153106**	5-8
152587	3-25	152745	6-9,6-10	152921	6-3	153107	5-6,5-8,5-51
152588	3-25	152746	6-9	152922	6-3	153108	6-6
152589	3-15	152750	6-20	152923**	5-25	153109	1-9,1-18
152590	3-25	152752	3-44	152924	5-26	153110	1-3,1-9
152591	3-25,7-7	152753	6-4	152925	5-26	153112	1-9
152592	3-26					153113	5-8,5-51
152593	3-17						

1149B

NUMERICAL INDEX (Continued)

Part Number	Page	Part Number	Page	Part Number	Page	Part Number	Page
153115	1-18	153262	3-86	153379	3-63	153487	5-3,5-4,5-15,5-31, 5-37,5-49
153116	1-8,1-9,1-14,1-24	153263	3-86	153380	3-63,3-82	153488**	5-2
153117	1-9	153264	1-7	153382	3-8,3-59	153489	3-33,7-11
153118	1-9	153265	1-21	153383	3-8,3-59	153491	3-34
153119	1-9	153266	1-21,2-17	153385	3-60	153492	5-26,6-27
153126	5-8,5-51	153267	1-27,3-69	153386	3-63	153493	6-20
153130**	5-8	153268	1-7	153397	3-82	153508	3-44
153139	3-44	153271	1-21	153388	5-2,5-12,5-14	153510	3-44
153157	6-5	153273	1-21,2-17	153390**	5-25	153513	3-44
153158	3-58	153274	1-21	153391	5-25	153514	3-44
153159	3-59,3-90	153276	1-21	153392	5-25	153516	3-44
153160		153277	1-21	153393	5-25	153518	3-45
through		153283	1-15,1-22,2-18	153394	5-25	153520	
153169	3-53,3-54	153284	1-15,1-21,2-17	153395	5-25	through	
153172	3-26,7-13	153287	3-69	153396	3-61	153528	3-53,3-54
153173	3-26,7-13	153288	3-86	153397	5-25	153530	3-17,7-9
153174	3-26,7-13	153291	3-47	153400	5-4,5-9,5-15,5-20, 5-21,5-26,5-28,5-49	153531	3-17,7-9
153175	3-26,7-13	153292	3-20			153532	3-17,7-9
153180	3-26,7-13	153293	3-20			153534	3-5,3-90
153181	3-26,7-13	153294	3-47	153403	5-25	153535	4-7
153183	3-26	153295	3-47	153409		153536	4-7
153184	3-35,7-13	153296	3-20	through		153537	2-24,5-8,5-28,5-35, 5-37,5-41,5-51,6-29
153185	3-57,3-79	153298	3-47	153435	3-53,3-54	153538	2-14,5-30,5-54
153186	3-57	153299	3-47	153436	3-53,3-55	153540**	5-14
153188	3-57,3-79	153300	3-20	153437	3-53,3-55	153541**	5-14
153189	3-57,3-79	153301	3-47	153438	3-53,3-54	153543	3-35,7-13
153190	3-57	153302	3-47	153440	3-53,3-54,3-88,7-7, 7-17	153545	3-35,7-13
153191	3-57,3-79	153303	3-47			153550	3-10
153192	3-57,3-79	153304	3-2	153441	5-38	153553	3-10
153193	3-57	153305	3-8	153442	2-14,3-10,3-81,3-83, 5-2,5-3,5-4,5-12, 5-13,5-14,5-20,5-29, 5-34,5-35,5-37,5-38, 5-41,5-42,5-43,5-50, 7-7	153558	3-10
153194	3-57	153310	3-8			153560	3-12,7-14
153195	3-57	153311	3-8			153562	3-10,3-12
153196	3-57,3-79	153312	3-2			153563	3-66
153198		153314	3-8			153564	3-66
through		153315	3-39,3-67,7-13	153444	1-9	153565	3-66,3-72
153207	3-58,3-78	153317	3-8	153445	1-9,5-26	153566	3-64
153208		153318	3-47	153451	6-10,7-8	153569	3-22
through		153319	3-39,3-67	153454	6-10,7-8	153570	3-64
153217	3-58	153320	3-39	153455	5-49	153572	1-19
153228	3-69	153321	3-39	153456	6-3,7-8	153573	3-10,3-12
153229	3-69	153322	3-47	153457	6-3,7-8	153574	3-10,3-12
153230	3-69	153323	3-20	153458	6-4	153576	3-20
153231	3-69	153326	3-11	153459	5-2,5-10,5-11,5-14, 5-29	153577	3-10
153233	3-69	153331	3-29,7-13	153460	6-3,7-8	153579	3-12
153234	3-69	153332	3-29,7-13	153461	6-3,7-8	153580	3-12
153235	3-19,3-69	153335	3-29,7-13	153462	6-3,6-17,6-25,6-27, 7-8	153581	3-47
153236	3-19,3-69	153337	3-29,7-13	153464	6-8,7-8	153582	3-8
153237	3-69	153340	3-29,7-13	153465	5-11	153583	3-22
153239	3-69	153341	3-29,7-13	153466	5-11,5-14	153584	3-22
153240	3-69	153342	3-60,4-7	153467	5-11	153585	3-10,3-12
153241	3-69	153343	3-60	153468	5-2,5-11,5-14,5-29	153586	3-2
153242	3-69	153345	3-60	153469	5-11	153587	3-3
153243	1-22	153346	3-60	153470	5-2,5-11,5-14,5-29	153588	3-66,3-72
153244	1-7	153347	3-60	153471	5-11	153589	1-19
153245	1-22	153350	3-60	153473	6-20,7-8	153590	1-19,1-26
153246	1-22	153351	3-60	153474	5-4	153591	1-19
153247	1-22,2-18	153352	3-50	153475	6-8,7-8	153592	3-52
153248	1-21,1-22,2-17,2-18	153355	3-60	153477	6-6,6-21,7-8	153593	3-52
153249	1-22,2-18	153356	3-60	153478	6-5,7-9	153594	3-66
153250	1-22,2-18	153358	3-60	153479	6-12,7-8	153595	1-19
153251	6-5,7-9	153359	3-59	153480	6-8,7-8	153596	3-48
153252	1-22,2-2,5-42	153360	3-59,3-84	153481	6-8,6-10,7-8	153598	3-49
153254	3-86	153361	3-59,3-84	153482	6-8,7-8	153600	3-39,3-64
153255	3-8,3-86	153364	3-59,3-84	153483	6-12,7-8	153601	3-47
153256	3-28	153365	3-59,3-84	153484	6-12,7-8	153602	3-46
153257	3-86	153367	3-22,3-59			153603	3-39,3-64
153258	3-86	153368	3-22,3-59			153604	3-49
153259	3-86	153375	3-59,3-84			153605	3-39,3-64
153260	3-86	153377	3-59,3-84	153486	5-29,6-22		
153261	3-86	153378	3-59				

I 149B

NUMERICAL INDEX (Continued)

Part Number	Page	Part Number	Page	Part Number	Page	Part Number	Page
153606	3-47	153796	1-3,1-27	153956	1-27	154068	2-6
153608	3-48,7-12,7-14,6-15	153799	3-13	153958	1-27	154069	2-6
153609	3-48,7-12,7-14,7-15, 7-16	153800	3-38	153959	1-27	154070	2-6
153610	3-65	153803	1-3,1-23	153962	4-7	154071	2-6
153611	3-65	153806	3-22	153963	4-7	154072	2-6
153615	3-65	153810	3-17,7-7	153964		154076	2-2
153619	1-3	153817	2-2,3-26,3-28,5-29	through		154079	2-11
153620	1-3	153819	3-39,6-24	153968	4-7	154080	2-6
153621	1-3	153820	3-41	153969	1-27	154081	2-7
153622	1-3,1-23,5-21	153823	3-20	153970	1-27	154083	2-9
153623	1-13	153824	3-20	153971	1-27	154084	2-11
153624	1-13	153830	5-7	153975	3-52	154085	1-6,2-2
153626	1-16,7-14	153833	5-7	153976	4-7	154086	1-8,2-6,2-7
153627	1-16,7-14	153834**	5-5	153977	4-7	154087	2-2
153629	1-16,7-14	153835**	5-5	153979	4-7	154088	2-2
153630	1-16,7-14	153836**	5-5	153984		154089	2-11
153631	1-3,1-25,5-49,6-24	153837**	5-5	through		154091	2-11
153632	1-16,7-14	153838	3-47	153987	1-27	154092	2-3
153633	1-3	153839	1-27,2-26,3-13,3-17, 3-35,7-16	153992	1-27	154095	2-12,2-13,2-23
153634	3-6,3-65,7-16	153841	2-8,2-15,3-10,3-15, 5-25,5-32,5-56,7-16	153993	1-17,1-27	154096	2-8
153635				154000	2-2	154097	2-17
through		153842	5-5	154001	2-6	154098	2-7
153638	1-18	153843	1-16	154002	2-6	154099	2-3
153639	1-20	153845	1-16	154003	2-6	154101	2-8
153643	3-48	153846	1-27	154004	2-6	154102	2-11
153644	3-48,7-12,7-14,7-15, 7-16	153847	1-27	154005	2-6	154105	2-10
153645	3-48,7-12,7-14,7-15	153876	1-27	154008	2-6	154106	2-2
153646	3-48,7-12,7-14,7-15	153877	1-27	154009	2-10	154107	2-17
153652		153878	1-27	154010	2-10	154109	2-2
through		153882	5-26	154011	2-10	154110	2-4
153667	3-70	153883	3-19,3-80	154012	2-10	154111	2-4
153670	3-49	153884	3-28,3-80	154013	2-6	154112	2-16
153671	1-17	153887	1-10	154014	2-10	154114	2-16
153672	1-18	153892	1-27	154015	2-11	154115	2-2
153674	1-3	153894	3-59,3-84	154016	2-6	154116	2-18
153676	3-13	153896	3-59,3-84	154017	2-11	154117	2-4
153678	3-13	153897	3-59	154018	2-10	154118	2-15
153682	3-13	153899	3-60	154019	2-9	154119	2-4
153683	3-13	153900**	5-8	154020	2-4	154120	2-6
153685	3-13	153901**	5-6	154021	2-4	154121	2-6
153686	3-13	153902	1-16	154023	2-6	154122	2-6
153687	3-13	153905	7-11	154025	2-11	154123	2-6
153689	3-13	153904	7-11	154027	2-11	154124	2-6
153690	3-13	153905	7-11	154029	2-9	154125	2-6,2-19,2-24
153692	3-13	153906	7-11	154030	2-9	154126	2-15
153695	3-13	153907	7-11	154032	2-9	154127	2-11,5-55
153696	3-13	153910	3-71	154033	2-8	154129	2-6
153697	3-13	153911	3-72,3-73	154034	2-8	154130	2-12
153698	3-13	153912	3-61	154036	2-10	154131	2-12,2-13
153699	3-13	153914	7-11	154037	2-15	154132	2-18
153700	3-13	153915	3-96	154039	2-15	154133	2-17
153701		153916	3-96	154040	2-10	154134	2-22
through		153917	3-96	154041	2-10	154135	1-20,2-22
153717	3-70,7-7	153918	3-96	154042	2-12,2-13,2-23	154136	2-22
153721	3-70	153919	3-68,7-12	154043	2-12,2-13,2-23	154137	2-22
153722	3-70	153920	5-10,7-12	154045	2-12,2-13,2-23	154140	2-10
153726		153924	7-12	154046	2-8	154141	2-15
through		153926	5-7	154047	2-10	154142	2-22
153729	3-70	153927		154051	2-11	154144	2-22
153751		through		154052	2-6	154145	2-18
through		153936	3-58	154053	2-8	154146	2-17
153767	3-70	153941	7-12	154055	2-6	154147	2-15
153771		153945	3-67,7-12	154056	2-12,2-13,2-23	154149	2-15
through		153946	3-26,7-13	154057	2-4	154153	2-15
153787	3-70,7-15	153947	3-26,7-13	154058	2-4	154154	2-9
153791	3-13	153948	3-26,7-13	154059	2-3	154156	2-12
153794	3-13	153949	3-26,7-13	154064	2-17	154165	2-12
153795	3-48,7-12,7-15	153950	3-26,7-13	154065	2-17	154166	2-12
		153952	1-27	154066	2-3	154172	2-12
		153955	1-27	154067	2-3	154173	2-12

1149B

NUMERICAL INDEX (Continued)

Part Number	Page	Part Number	Page	Part Number	Page	Part Number	Page
154175	2-7	154626	3-24,3-67,7-11	154787	7-14	155159	3-53,3-54
154176	2-2,5-42	154627	3-24,7-11	154789	3-10,7-14	155176	3-53,3-55
154178	2-10	154628	4-7	154792	3-77	155177	3-53,3-55
154179	2-7	154630	6-14	154793	5-18	155178	3-53,3-55
154183	2-7	154632	6-13	154858	5-6	155179	3-53,3-55
154184	2-7	154636	6-13	154869**	5-8	155180	3-53,3-55
154189	2-12,2-13	154638	3-41	154870	6-17,6-25	155191	
154190	2-13,7-17	154539	3-48,7-12	154872	3-3,3-68,3-74	through	
154191	2-11	154642	3-48	154873	3-76	155218	3-53,3-54
154193	2-15	154643	3-45	154874	5-9	155219	3-53,3-54
154194	2-12,2-13,2-23	154645	3-10	155000	3-52	155246	3-53,3-55
154197	2-4	154646	3-49,7-12	155021	3-58	155247	3-53,3-55,7-12
154198	2-4	154647	3-49,7-12	155022	6-2	155248	3-53,3-54
154199	2-2	154649	3-68	155023	2-5,5-40,5-56,6-2,6-27	155249	3-53,3-54
154200	2-8	154650	3-39			155250	3-53,3-54
154201	2-2	154651	5-22	155025		155286	
154202	2-4,2-5	154655	5-22	through		through	
154203	2-4	154661	6-14	155036	1-15	155290	3-53,3-54,7-12
154204	2-4,2-5	154662	1-6,2-3	155037	1-15,3-60	155296	
154206	2-12,2-13	154663	1-6,2-3	155038	1-15	through	
154207	2-12	154664	6-17,6-25	155039	1-15	155300	3-53,3-54
154208	2-2	154665	6-13	155040	1-15	155306	3-53,3-54
154209	2-13	154666		155041	3-8,7-11	155307	3-53,3-54
154210	2-4	through		155042	3-8,7-11	155311	
154211	2-4	154669	3-47,7-12	155044	3-20	through	
154212	2-4	154670	3-60,3-85	155045	5-4,5-12,5-13,5-20	155315	3-53,3-54
154215	2-11	154671	3-60,3-85	155046	3-20	155326	
154217	2-10	154672	3-60	155047	3-20	through	
154225	2-13	154673	3-2,3-52	155049	3-52	155330	3-53,3-54
154226	2-13,2-17	154674	4-7	155051	3-76	155336	
154227	2-17	154676	4-7	155052	1-23	through	
154236	2-8	154680	4-7	155053	3-76	155340	3-53,3-54
154237	2-11	154681	1-19	155060	3-47	155366	
154238	2-7	154682	1-19	155061	3-47	through	
154239	2-7	154684	4-7	155063	5-20,5-21	155370	3-53,3-55
154240	2-11,7-14	154685	4-7	155064	6-4	155432	
154241	2-11,2-14	154688	3-10	155066	3-52,7-14	through	
154251	5-28,5-40	154691	3-47	155067	3-52	155479	3-45
154253	3-28	154692	3-47	155068	3-61	155497	3-44
154256	5-27,5-38,5-31	154693	4-7	155069	3-61	155547	5-6
154258	5-30	154694	1-11,2-9,3-19,3-20	155071		155548	5-6
154308	5-2,5-14	154695**	5-6	through		155558	6-16
154330	2-11	154696	6-3	155076	3-47	155559	6-16
154350	7-13	154697	5-6	155081	3-28	155560	5-16
154373	3-83	154698	3-59,3-84	155083	5-2,5-9,5-14,5-27,5-30	155561	6-16
154375	4-4,4-7	154723	7-14			155563	5-21
154386	2-11	154726	7-14	155084	6-25	155564	6-16
154399	5-2,5-14,5-27,5-30,5-34	154727	3-74	155085**	5-8	155564	6-16
		154732	6-25	155086	5-8	155565	3-13,7-7,7-15
154404	5-3,5-4	154741	5-10	155087	5-8	155566	3-13,7-7,7-15
154409**	5-33,5-39	154742	3-58,3-75	155088**	5-7	155569	6-20
154433	5-28,5-31,5-54	154743	3-62	155090	3-33	155581	3-56
154516	3-77,3-92	154747	6-17	155091	3-86	155582	3-56
154517	3-77	154750	7-14	155096	3-33,7-11,7-14	155583	3-56
154519	3-13	154753	3-76	155099	3-47	155584	3-55
154520		154754**	5-19	155100		155585	4-7
through		154755	3-77	through		155586	3-31
154535	1-15	154756	5-17	155125	3-53,3-54,7-12	155587	3-31
154536		154760		155126	3-53,3-55,7-12	155589	3-31
through		through		155127		155591	6-6
154549	3-43	154769	3-78	through		155592	6-16
154613	3-49,3-96,7-12,7-17	154770	3-79	155130	3-53,3-54,7-13	155593	4-7
154614	3-19,3-59	154771	3-79	155131	3-53,3-55	155594	4-7
154616	3-42	154777	5-20	155132	3-53,3-54	155597	5-2,5-16
154620	3-33	154778	3-80,3-81	155133	3-53,3-55	155600	4-7
154621	3-33	154779	6-25	155134	3-53,3-55,3-57,3-79	155601	4-7
154622	3-33	154780	3-82	155135	3-53,3-55,3-60	155602	4-7
154623	3-24,7-11	154782	7-14	155141		155603	4-7
154624	3-24,7-11	154783	1-24,1-25	through		155605	4-7
154625	3-24,7-11	154785	3-83	155145	3-53,3-55	155611	4-7

1149B

NUMERICAL INDEX (Continued)

Part Number	Page	Part Number	Page	Part Number	Page	Part Number	Page
155613	4-7	155797	3-83	156993	5-2,5-14,5-27,5-30, 5-34,5-39	157227	6-15
155614	5-10	155798	3-83			157228	6-15
155615	1-2,1-27	155799	3-83	157000		157229	6-15
155616	1-8	155846	5-18	through		157230	6-4
155618		155848		157004	3-44	157231	6-4,6-17
through		through		157007	3-44	157232	6-4,6-17
155673	3-45	155851	1-25	157009	3-44	157233	6-15
155693	3-45	155852	3-77	157011	3-44	157234	6-15
155697	3-44	155853	3-77	157013	3-44	157235	5-15
155699	3-44	155854	3-77	157015	3-44	157237	3-35
155701	3-44	155855	3-77	157017	3-44	157238	3-42,3-57,3-60,3-88, 7-9,7-10
155703	3-44	155856	3-77	157018	3-44		
155704	3-44	155857	3-77,5-29	157030	3-44	157240	3-49,3-57,3-60,3-79, 3-83,3-96,7-7,7-9, 7-10,7-12,7-13,7-17
155705	3-45	155858	5-20,5-21,6-3,7-8	157031	3-73		
155706	3-45	155859	1-23,3-76,5-10,5-24, 6-2,6-3,6-20,6-28	157032	3-73		
155707	3-45			157033	3-73	157241	3-10
155708	3-44	155860	1-23,3-76,5-10,5-24, 5-29,6-2,6-3,6-20, 6-28	157034	3-73	157243	3-48
155709	3-45			157035	3-73	157247	3-47
155710	3-44			157037	3-73	157251	3-62
155713	3-49,7-14	155861	1-23,3-76,5-10,5-24, 5-29,6-2,6-3,6-20, 6-28	157038	3-72	157252	3-62
155714	3-82			157039	3-72	157253	3-62
155716	3-84			157040	3-72	157254	3-62
155718	6-17,6-25	155862	5-2,5-14	157041	3-72	157255	3-62
155721	3-82	155864	3-10,7-14	157042	3-72	157257	3-62
155723	5-10	155865	3-10,7-14	157043	3-72	157258	3-47
155727	1-25	155868		157044	3-72	157259	3-81
155728	1-25	through		157045	3-72	157260	5-10
155729	1-25	155870	3-44	157046	3-71	157261	3-33
155731	1-25	155877	3-44	157047	3-64	157262	3-74
155732	1-25	155878	3-44	157048	3-64	157263	3-81
155733	1-25	155885		157049	3-64	157264	3-81
155736	3-49	through		157070		157265	3-80
155737	3-49	155891	3-45	through		157269	3-52
155738	3-49	155896	3-13,7-7,7-15	157100	3-51,7-7,7-12,7-13, 7-14,7-17	157272	3-74
155739	1-24	155897	3-13,7-7,7-15			157273	3-74
155741	1-24	155899	5-2,5-14	157101		157274	3-47,7-10
155743	1-24	155913	3-51	through		157275	3-47,7-14
155744	1-24	155915	3-51	157106	3-52,7-12,7-13	157276	6-25
155745	1-25	155916	3-51	157151	3-68	157278	5-11,5-12,5-27,5-30
155746	1-25	155917		157152	5-10	157280	5-13
155747	1-25	through		157153	5-10	157281	5-13
155749	3-52	155929	3-51	157154	5-10,5-29	157282	5-13
155750	2-12,2-13,2-20,2-22, 2-23,2-25,3-4,3-26, 3-27,3-36,3-47,5-17, 5-29,6-19,6-25	155933	3-48,7-16	157155	5-10	152283	6-25
		155934	3-48,7-16	157156	5-10,5-29	157285	6-25
		155935	3-48,7-16	157157	5-10	157286	6-25
		155936	3-48	157158	5-10	157288	2-21
155751	2-15,2-22,3-35,3-47, 3-66,3-83,5-20,5-21, 6-19	155937	3-48	157159	5-9,5-10	157289	3-6
		155938		157160	5-9	157290	3-6,3-7
		through		157163	3-72	157291	3-6
155752	1-23,3-47,6-22,6-24	155942	3-48,7-16	157164	3-48,7-14	157307	6-13
155753	2-12,2-13,2-24,3-35, 3-47,5-28,5-29,5-30, 6-19	155944	2-24	157191	3-75	157308	6-13
		155946	3-48	157192	3-75	157309	6-13
		155948	3-48	157193	3-75	157310	6-13
155754	3-47,6-22,6-25	155954	2-24,3-2,3-94	157194	3-35	157311	3-81
155755	2-2,3-47,6-19	156093	3-14	157198	3-75	157312	6-25
155756	3-57	156501	6-24	157200	3-49,3-57,3-60,3-79, 7-7,7-9,7-10	157313	6-25
155758	3-58	156503	2-9			157314	6-25
155759	3-58	156509	2-10	157205	3-49	157315	6-25
155765	3-58	156516	2-10	157206	3-49,7-17	157316	6-25
155766	5-10	156536	3-33	157207	3-49,7-17	157317	6-25
155767	3-48	156572	3-41	157216	6-15	157319	6-25
155784	3-52	156574	2-7,3-5	157217	6-15	157320	
155785	5-18	156591	2-14	157218	6-15	through	
155788	3-83	156630	2-10	157219	6-15	157323	1-15
155789	3-83	156632	2-4,3-24,7-11	157220	6-15	157325	
155790	3-83	156644	2-12,2-13,2-23	157221	6-15	through	
155791	3-83	156663	2-12,2-13,2-23,3-83	157222	6-15	157367	1-15
155792	3-83	156740	5-29,5-35,5-54,5-56	157223	6-15,6-24	157393	5-10
155793	3-83	156770	5-2,5-14,5-27,5-30, 5-34,5-39	157224	6-15	157395	6-25
155795	3-83			157225	6-15	157396	5-25
155796	3-31,3-83	156976	6-19	157226	6-15	157397	6-25



1149B

NUMERICAL INDEX (Continued)

Part Number	Page	Part Number	Page	Part Number	Page	Part Number	Page
157398	3-47	157875	3-80	158341	3-85	159976	2-27
157399	5-10	157876	3-80	158342	3-85	160192	
157508	3-84, 3-85	157877	3-80	158343	3-85	through	
157509	3-54	157878	5-19	159346	3-84	160222	3-51
157510	3-86	157879	5-19	158347	3-85	160223	6-16
157511	3-69	157880	5-19	158348	3-85	160224	5-16
157513	3-57	157881	5-19	158349	3-84	160225	j-16
157514	3-92	157882**	5-19	158351	3-84	160226	6-8, 6-18
157530	3-57, 3-79	157883**	5-19	159352	3-22	160227	6-8
157531	3-79	157884	3-51, 7-17	158353	3-22	160229	6-21
157532	5-10	157885	3-48	158354	3-22	160282	5-23
157589	3-81	157887	3-50, 3-51, 7-15, 7-16	158357	3-85	160283	5-23
157600		157889	3-51, 7-13, 7-15, 7-16, 7-17	158359		160284	6-8, 6-18
through				through		160325	6-19
157634	3-42	157890		158362	1-26	160326	6-19
157635	3-44	through		158365	3-10	160328	6-19
157636		157893	3-51, 7-15, 7-16, 7-17	158406		160332	6-19
through		157899	3-50, 3-51, 7-13, 7-15, 7-16, 7-17	through		160334	6-19
157641	3-44, 3-45			158445	1-15	160336	6-19
157642	3-42, 3-45	157940		159447	1-15, 3-79	160339	5-28, 5-31, 5-41
157643	3-44	through		158448		160341	5-41
157644		157947	1-15	through		160344	5-41
through		157948	1-15, 3-57, 3-79	159455	1-15	160349	5-41
157647	3-44, 3-45	157949		158491	5-20	160357	6-19
157648		through		158492	5-20	160358	6-19
through		157971	1-1	159493	5-20	160359	6-19
157657	3-44	157973	3-92	158494	5-20	160361	
157659	3-44	157975	3-52, 7-7	158501	1-24	through	
157660	3-44	157979	3-38, 7-7	158649	5-40, 5-41	160365	6-19
157662		157980	5-17	158712	2-21	160389	6-19
through		157981	5-17	159716	2-21	160394	5-16
157675	3-44	157982	5-17	158723	2-21	160395	6-19
157678	3-44	157984	5-17	158732	2-21	160411	6-19
157716		157985	5-17	158733	2-21	160461	5-19
through		157986	5-17	158734	2-21	160468	3-79
157724	3-44	157987	4-7	158740	2-21	160489	3-78
157726	3-44	157989	1-27	158741	2-21	160490	3-79
157729		157990	3-8	158753	2-20	160491	3-79
through		157991	3-8	159754	2-20	160493	3-79
157779	3-45	157992	5-10	158788	2-21	164095	3-79
157792	3-44	157993	5-10	158859	2-20, 2-27	160498	3-79
157823		157997	6-25	159204	5-49	160499	3-79
through		157998	6-4, 6-25	159205	5-12	160500	3-79
157829	3-45	157999	5-12	159274	5-12	160502	3-79
157843	3-80	158163	2-2, 2-12, 2-13	159275	5-12	160503	3-79
157844	3-80	158164	2-2	159278	1-17	160505	
157845	3-80	158250	5-40, 5-42, 5-44, 5-46, 5-55, 6-27	159279	1-17	through	
157846	3-80			159281	1-17	160514	3-78
157847	3-48	158252	5-40, 5-42, 5-44, 5-46, 5-55, 6-27	159282	1-17	160523	3-90
157849	3-48			159284	1-17	160527	
157850	3-48	158258	5-37	159285	1-17	through	
157851	3-48	158259	5-35	159287	1-17, 2-27	160536	3-78
157852	3-48	158268	2-11	159320	6-29	160568	3-90
157854	3-48	158272	6-2	159321	6-29	160569	3-90
157855	3-48	159278	5-2, 6-3	159322	6-29	160572	3-47
157856	3-81	158279	6-20	159335	7-14	160573	3-47
157857	3-81	158283	6-19	159356	7-15	160574	3-79
157858	3-81	158286	5-27, 5-29, 5-30, 5-37, 5-33, 5-41, 5-56	159357	5-12	160576	3-47
157859	3-81			159362	3-56	160577	3-47
157861	3-81	158304	3-78	159366	3-94	160578	3-79
157862	3-81	158314	3-2, 3-94	159369	7-15	160584	3-81
157863	3-81	158315	3-2, 3-94	159370	7-15	160585	3-81
157865	3-80	158316	3-2, 3-94	159373	5-6	160586	3-81
157866	3-80	158317	3-2, 3-94	159375	5-21	160587	3-81
157867	3-80	158318	3-94	159390	5-23	160588	3-81
157868	3-80	158334	3-84, 3-85	159395	3-77	160589	3-81
157869	3-80	158335	3-28, 3-84	159397	6-18	160650	3-52
157870	3-80	158337	3-85	159660		160687	6-4
157871	3-80	158339	3-84	through		160751	3-44
157873	3-80	158340	3-85	159669	1-17	160755	3-45

1149B

NUMERICAL INDEX (Continued)

Part Number	Page	Part Number	Page	Part Number	Page	Part Number	Page
160831	6-19	161995	5-35	162882	2-2A	163640	5-27
160843	3-22	161998	5-39	162883	2-2A	163641	5-27,5-30
160844	3-44	162012	7-16	162884	2-2A	163642	5-27,5-30
160847	6-13	162013	7-16	162885	2-9	163643	5-28
160883	6-8	162056	3-45	162886	2-9	163644	5-28,5-31
160886	3-87	162058	3-45	162891	2-13	163646	5-28,5-31
160937	3-87	162059	3-49	162892	2-13	163696	6-22
160938	3-87	162298	3-48	162893	2-13	163697	6-22
160939	3-87	162333	1-2,1-3,2-2,2-3, 5-37,5-41	163040	5-30	163775	2-16
160940	3-87			163115	5-24	163776	3-5
160964	6-19	162337	2-13	163116	5-24	163778	3-5
160965	6-19	162357		163117	5-24	163783	3-5
160966	6-19	through		163118	5-24	163786	3-5
160974	5-27,5-30	162360	6-21,6-24	163119	5-24	163787	3-5
160999	3-45	162361	6-21	163146	3-93	163788	3-5
161081	3-45	162370	5-10	163147	3-93	163791	3-5
161082	3-52	162436	2-13	163148	3-93	163795	6-22
161087	3-35	162437	2-13	163150	3-93	163796**	5-23
161100	2-2A	162461	6-20	163151	3-93	163802	6-22
161137	3-92	162484	3-49	163152	3-93	163803	6-22
161138	3-92	162485	1-10	163153	3-93	163804	6-22
161140	3-58	162488	3-31	163157	3-93	163807	6-22
161141	3-58	162539	3-44	163158	3-93	163808	6-22
161238	6-24	162573	3-19	163159	3-93	163809	6-22
161239	6-24	162590	5-2,5-25	163161	5-24	163810	6-22
161250	3-58	162605	3-44	163162	3-52	163813	2-16
161260	3-58	162627	5-39	163183	3-89	163814	2-16
161261	3-58	162636		163184	3-89	163816	1-9,2-5
161269	3-88	through		163185	3-89	163817	1-9,2-5
161270	3-88	162640	3-53,3-54	163250	3-89	163852	1-15,2-24
161271	3-88	162641	2-21	163251	3-89	163943	3-49
161272	3-88	162643	2-21	163252	3-89	163944	3-49
161273	3-88	162645	2-21	163254	3-89	163947	3-90
161278	3-88	162646	2-21	163267	4-5	163948	3-5,3-90
161279	3-88	162647	2-21	163268	4-5	163949	3-5,3-90
161280	3-88	162648	2-21	163269	4-5	163951	3-5,3-90
161293	1-17	162649	2-21	163271	3-49	163954	3-5,3-90
161294	1-17	162650	2-21	163292	3-87	163955	3-90
161295	1-17	162652	2-21	163293	3-87	163956	3-5,3-90
161301	1-17	162653	2-21	163294	3-87	163957	3-5,3-90
161306	5-3	162654	2-21	163295	3-45	163958	3-5,3-90
161342	3-33	162655	2-21	163308		163959	3-90
161346	1-13,2-10,3-37,3-38	162656	2-21	through		163960	3-5,3-90
161347	1-20,2-6,2-22,3-10, 3-12,3-28,3-29,3-30, 3-72	162657	2-21	163314	3-45	163962	1-9
161348	1-11	162658	2-21	163316	6-20	163963	2-5
161362		162659	2-21	163359	2-21	163964	2-5
through		162660	2-21	163360	2-21	163966	6-20
161365	3-45	162661	2-21	163368	2-9	163968	3-52
161366		162663	2-21	163440	1-6,2-3	163979	2-19,2-27
through		162664	2-21	163445	2-13,2-26	164005	2-19
161377	3-45	162665	2-21	163459	3-19	164078	2-19
161441	7-15	162666	2-21	163460	2-3	164079	2-17
161491	3-77,3-92	162668	2-21	163461		164127	2-5
161492	3-77,3-92	162684	4-6	through		164131	2-5
161525	1-23,2-5,6-22	162685	4-6	163464	1-17	164132	1-9
161526	1-20,6-22	162686	2-21	163503	3-19	164133	1-9,1-23
161578	4-6	162687	5-39	163504	1-17	164138	2-25
161579	4-5,4-6	162692	5-35	163505	1-17	164143	2-24
161580	4-5,4-6	162835	6-20	163506	2-13	164144	2-24
161649	3-49	162861	4-5,4-6	163518	7-17	164145	2-24
161705	5-39	162866	7-16	163519	2-9	164146	2-24
161708	5-29,5-39	162873	2-19,2-25	163535	3-90	164148	2-24
161747	5-29	162874	2-19,2-25	163536	2-13	164149	2-24
161748	5-33,5-39	162875	2-19,2-25	163537	2-13,2-23	164150	2-24
161750	5-10	162876	2-19,2-27	163590	3-19	164154	2-24
161767	3-58	162878	2-2A	163635**	5-27	164155	2-24
161769	3-44	162879	2-2A	163636	5-27,5-30	164156	2-24
161994	5-35	162880	2-2A	163637	5-27,5-30	164157	2-24
		162881	2-2A	163638	5-27,5-30	164160	2-25
				163639	5-27,5-30	164161	2-24

1149B

NUMERICAL INDEX (Continued)

Part Number	Page	Part Number	Page	Part Number	Page	Part Number	Page
164162	2-24	164611	3-5	165027	5-49	172700**	5-36
164163	2-24	164612	4-8	165028	5-49	172701**	5-33
164164	2-24	164613	5-34	165029	5-49	172702**	5-33,5-39
164165	2-24	164614	5-34	165030	5-49	172703**	5-33,5-39
164168	2-24	164615	5-37	165031	5-49	172711**	5-33
164169	2-24	164616	5-35	165032	5-49	172714	5-36
164192	6-20	164617	2-14	165033	5-49	172715	5-33,5-39
164201	2-5	164618	5-37	165034	5-49	172717	5-36
164218	3-45	164619	5-35	165035	5-49	172718	5-35
164219	3-5	164620	5-35	165037	5-49	172719	5-36
164220	3-5	164624	5-35	165039	5-49	172723	3-44
164235**	5-23	164629	5-37,5-38	165060	6-27	172758	5-33,5-39
164238	6-20	164644	2-20	165080	5-49	172762	5-36
164239	6-20	164645	2-20	165103	5-43,5-56	172763	5-33,5-39
164269	2-5	164646	2-20	165118	5-46	172791**	5-33
164270	3-19	164647	2-20	165138	5-49	172938	4-6
164271	6-24	164649	2-20	165139	5-49	172942	6-24
164311	3-49	164650	2-20	165141	5-49	172943	6-24
164313	3-41	165651	2-20	165142	5-49	172961	5-37
164314	3-26	164652	2-20	165143	5-49	172971	6-19
164316	3-26	164653	2-20	165145	5-49	172976	2-13
164317	3-58	164656	2-20	165167	5-46	173013**	5-36
164327	1-23,2-5	164660	2-20	165168	5-44,5-46	173014**	5-36
164331	5-29	164718	2-14	165260	5-49	173015**	5-36
164332	5-29	164719	2-14	165261	5-40,5-46,5-48	173016**	5-36
164333	5-29	164720	2-14	165269	5-49	173017	5-36
164334	5-28	164721	2-14	165294	5-49	173018	5-35
164345**	5-29	164722	2-14	165343	5-50	173019	5-36
164348	3-45	164723	2-14	165378	6-22	173028	2-25
164362	5-4	164724	2-14	165451	5-49	173029	2-25
164375	2-5	164725	2-14	165522	5-49	173095	2-25
164376	2-5	164726	2-14	165523	5-49	173096	2-25
164379	2-20	164727	2-14	170164	3-44	173124	2-20
164383**	5-23	164728	2-14	171522	6-19	173141	3-49
164384	5-27,5-29,5-30	164729	2-14	171541	5-56	173144	
164396	5-28	164730	5-37	171555	6-27	through	
164397	5-28	164731	2-14	172181	3-92	173147	6-24
164398**	5-29	164732	2-14	172190	3-92	173206	5-45
164399	5-29	164733	5-35	172226	3-92	173207	5-45
164400	5-29	164734	2-14	172500		173238	5-49
164401	5-29	164735	2-14	through		173256	5-49
164412**	5-29	164754	5-39	172564	3-50	173331	6-24
164419	5-29	164899	5-33	172591	3-50	173332	6-24
164420	5-29	164900	5-33	172593		173363	6-24
164421**	5-29	164901	5-33,5-39	through		173450	3-35
164422**	5-29	164902	5-33	172597	3-50	173453	2-23
164434	1-14	164903	5-33,5-39	172599	3-50	173712	2-2
164435	1-14	164926	2-14	172600		173713	5-36
164457	1-15	164927	5-37	through		173724	6-3
164479	4-5	164928	5-37	172607	3-50	173872**	5-30
164485	2-20	164955	5-35	172618	3-50	173874	5-30
164494	2-15	164956	5-35	172619	3-50	173875	5-30
164495	2-15	164958	3-89	172635	2-14	173876	5-30
164498	3-44	164960	3-89	172636	2-14	173877	5-30
164503	6-23	164999	5-38	172646	5-34,5-41	173878	5-31
164572	3-91	165007	5-49	172654	5-34	173879	5-30
164573	3-91	165008	5-49	172655	5-34	173907	2-21
164574	3-91	165009	5-49	172658	5-34	173908	2-21
164575	3-91	165010	5-49	172659	5-34	173909	2-21
164576	3-91	165011	5-49	172682	5-34,5-41	173912	2-21
164577	3-91	165012	5-49	172683	5-34,5-41	173913**	5-30
164586	3-44	165014	5-49	172684	5-34	173914	5-32
164594	3-52	165015	5-49	172685	5-34	173915	5-32
164600	3-91	165016	5-49	172693**	5-33	173916	5-32
164603	4-8	165019	5-49	172694**	5-33	173917	5-30
164604	5-34	165020	5-49	172695	5-33	174086	3-44
164606	5-35,6-24	165021	6-22	172696**	5-33	174250	2-27
164607	5-35	165022	5-49	172697	5-33	174306	6-19
164609	5-33	165023	5-49	172698**	5-33,5-39	174410	2-23
164610	5-35	165024	5-49	172699**	5-34	174411	2-23

1149B

NUMERICAL INDEX (Continued)

Part Number	Page	Part Number	Page	Part Number	Page	Part Number	Page
174412	2-23	176695	3-58	176821	3-58	179239	3-95
174413	2-23	176696	6-29	177010	5-56	179240	3-95
174414	2-23	176697	6-29	177034	5-36	179241	3-95
174415	2-23	176698	6-29	178261	5-39	179282	4-9
174416	2-23	176703	2-2A	178387	5-50	179283	4-9
174421	2-23	176704	3-87	178389	5-50	179290**	5-54
174422	2-23	176708	5-52	178390	5-50	179291**	5-54
174438	5-28,5-31	176711	5-52	178391	5-50	179293**	5-53
174458	5-49	176712	5-52	178392	5-50	179294	5-53
174482	3-49	176752	2-27	178729	5-49	179295	5-54
174483	3-49	176770	2-27	178840	5-56	179296	5-54
174491	2-13,7-17	176772	2-27	178841	5-56	179297	5-41
174650	5-34	176774	2-27	178843	5-56	179298	5-41
174651	5-34	176782	2-27	178859	5-56	179299**	5-39
176130	5-36	176784	2-27	178868	5-56	179300**	5-39
176131	5-36	176786	5-52	178886	5-56	179301	3-95
176132	5-36	176787	2-27	178887	5-56	179303	5-53
176133	5-36	176788	6-29	178888	5-56	179304	5-53
176134	5-33	176789	2-27	178893**	5-51	179305**	5-53
176278	2-24	176790	2-27	178894**	5-51	179306	5-53
176642	3-47	176792	2-27	178895	5-51	179307	5-56
176651	3-44	176793	2-27	178897	5-51	179309	3-95
176659	2-2A	176794	2-27	178900**	5-2	179310	3-95
176661	2-2A	176795	2-27	178914**	5-51	179311**	5-54
176663	2-2A	176796	2-27	179100	4-3	179312**	5-54
176668	5-52	176797	2-27	179101	4-3	179366	3-95
176669	5-52	176799	2-27	179102	Plate 4-9	179367	5-53
176670	5-52	176802	2-27	179103	4-9	179368	3-95
176671	5-52	176803	2-27	179104	4-9	179369	3-95
176672	2-2A	176804	2-27	179105	4-9	179370	5-53
176673	2-2A,6-3	176805	2-27	179106	4-9	179371	5-53
176677	2-27	176806	2-27	179130	5-41	179372	5-39
176678	2-27	176808	2-27	179131	5-39	179375	5-53, 5-56
176691	2-2A	176809	2-27	179235	3-95	179376	5-56
176692	6-29	176810	6-29	179236	3-95	179377	3-95
176693	6-29	176811	6-29	179237	3-95	179378	5-54
176694	6-29	176812	6-29	179238	3-95	179495	5-39